



LED version ^

LCD version >



## WI-125 SST Indicator User's Manual

#### **UNITED STATES**

This equipment has been tested and found to comply with the limits for a Class A digital device, pursuant to Part 15 of the FCC Rules. These limits are designed to provide reasonable protection against harmful interference when the equipment is operated in a commercial environment. This equipment generates, uses, and can radiate radio frequency energy and, if not installed and used in accordance with the instruction manual, may cause harmful interference to radio communications. Operation of this equipment in a residential area is likely to cause harmful interference in which case the user will be required to correct the interference at his own expense.

#### **CANADA**

This digital apparatus does not exceed the Class A limits for radio noise emissions from digital apparatus set out in the Radio Interference Regulations of the Canadian Department of Communications.

Le present appareil numerique n'emet pas de bruits radioelectriques depassant les limites applicables aux appareils numeriques de la Class A prescrites dans le Reglement sur le brouillage radioelectrique que edicte par le ministere des Communications du Canada.



## **CAUTION**

**Risk of electrical shock. Do not remove cover. No user serviceable parts inside. Refer servicing to qualified service personnel.**

**Weigh-Tronix reserves the right to change specifications at any time.**

# Table of Contents

Table of Contents .....	3
Specifications .....	4
Introduction .....	5
Operations Mode .....	5
Keyboard .....	5
Key Functions .....	6
Error Messages .....	6
Indicator Operation .....	7
Powering Up .....	7
Annunciators .....	7
Gross/Tare/Net Weighing Operations .....	8
Gross Weighing .....	8
Net Weighing .....	8
Pushbutton Tare .....	8
Quick Keypad Tare Entry .....	9
Selecting a Tare Register .....	9
Entering and/or Changing Values in Tare Registers .....	9
Clearing a Tare Register .....	10
Clearing the Active Tare .....	10
Net Weighing Operation .....	10
Entering Cutoff Values Through the Front Panel .....	11
Controlling Cutoffs .....	11
To Access the Control Function .....	12
To Activate and Control Cutoffs .....	12
ID Number Entry .....	13
Viewing and Setting Time .....	13
Viewing and Setting Date .....	14
Single Accumulator with Counter .....	15
Weighing and Printing .....	15
Viewing Accumulated Weight and Count .....	18
Enabling or Disabling Display Backlight .....	19
Operations Menu .....	19
Indicator Diagnostics .....	20
Test Mode .....	20
Transmitting Data .....	22
RS-232 Output .....	22
Communication Protocol .....	22

**Pages are numbered consecutively beginning with the cover page.**

# Specifications

Dimensions:	8.25" x 6.25" x 4" (210mm x 159mm x 102mm) without bracket 10" x 9" x 5.5" (254mm x 229mm x 140mm) with bracket	
Power:	115 volts AC @ 50 mA / 230 volts AC @ 25 mA, 50-60 Hz single phase Optional - 12 VDC (LCD version only)	
Display:	8 digits, 7-segment LCD or LED, 0.6 inch high with annunciators and backlighting (LCD only)	
Display Averaging:	1 to 10 display periods	
Display Rate:	One, two or five times per second	
Agencies:	NIST Handbook 44, Class III, IIL, 10,000 divisions. LCD & LED - Certificate of Conformance #92-167.A4 Consumer and Corporate Affairs, Canada. LCD & LED Approval #AM4868 UL/CUL CSA FCC Class A	
Accuracy :	Span: $\pm 5.0$ ppm/C Span: $\pm 10$ ppm/C	Zero: $\pm 0.066$ uV/C (-10 to 40°C) Zero: $\pm 0.13$ uV/C (-30 to 60°C)
Linearity:	$\pm 0.005\%$ of capacity, maximum	
Repeatability:	$\pm 0.005\%$ of capacity, maximum	
Hysteresis:	0.005% of capacity, maximum	
Weigh bar drive capacity:	Up to eight 350 ohm weigh bars for LCD version. Up to twelve 350 ohm weigh bars for LED version.	
Environment:	-10 to 40°C (14 to 104°F) for HB-44 specs 10 to 90% relative humidity	
Internal Resolution:	810,000 at 3 mV/V. 1 mV/V = 270,000 counts	
A to D conversion rate:	30 times per second (60/second for LED version)	
Analog Range:	-0.14 to +3.5 mV/V	
Capacity:	0.1 to 999999, programmable to any number between these limits.	
Divisions:	.0001 to 20000, programmable to any division size between these limits.	
Push Button Zero Range:	0 to $\pm 100\%$ of capacity; programmable independent positive and negative limits; unit will not allow zeroing beyond capacity.	
Tare:	The unit may be configured to have pushbutton tare and numeric tare. Tares may tare only positive gross weights up to the capacity of the unit.	
Motion Detection Window:	Programmable from 0 to 999999 divisions, decimal entries are accepted.	
Automatic Zero Tracking:	Window: Programmable from 0 to 999999 divisions, decimal entries are accepted.	
	Net Mode	
	Tracking:	May be enabled or disabled
	Rate:	0.1 division per second
	Starting Delay:	2 seconds
Linearity Adjustment:	Second order correction provides smooth curve fit through three points--zero, linearity, span.	
VIBRATION COMPENSATION		
Analog Low Pass Filter:	Two section with .10 second time constant for low power analog and .06 second time constant for standard analog.	
Software Low Pass Filter:	One section with .05 second time constant.	

# Introduction



## Attention

*The socket-outlet must be installed near the equipment and easily accessible.*

The WI-125 SST is a full featured indicator in a stainless steel enclosure and includes a numeric keypad. The weight sensor interface termination and RS-232 termination are made within the enclosure.

This set of instructions is divided into the following sections:

- Introduction
- Operations Mode
- Keyboard
- Indicator Operation
- Indicator Diagnostics
- Transmitting Data
- Specifications

# Operations Mode

*This manual is valid for Rev. F or higher software.*

Operations mode contains all normal weighing operations. In this mode you can view or set the following parameters if the unit is so configured:

- push-button tare
- quick keypad tare entry
- one to ten tare registers (numbered 0-9)
- identification number
- time
- date
- backlight (LCD version only)

Any combination of these items can be secured behind a security code. Any items secured by the code number can be viewed but not changed unless you enter the security code.

# Keyboard

The keyboard consists of 16 keys. Five keys, or buttons, provide all the basic weighing functions:

- Tare
- G/N
- Zero
- Print
- Units

The other keys are used to access the menus for purposes of accessing information, testing the indicator, and configuration. The keyboard is shown in Figure 1.

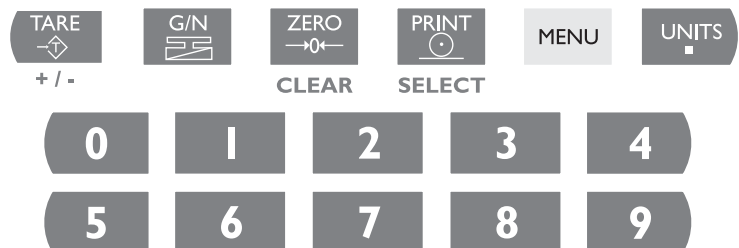

**Figure 1**  
WI-125 Keyboard

## Key Functions



Enters a pushbutton tare in gross/net operation. During data entry this key is used to toggle between positive and negative values. Used to enter a dash (—) in ID numbers.



Accesses the gross weighing mode from any other function and activates the net weighing mode if a tare is active.



Zeros the scale in gross or net weigh mode. This button also clears keyed in digits on the display before they are accepted.

**CLEAR**



Sends a print command and is used to select menu items.

**SELECT**



Used to access menus and move among choices in a menu.



Changes the unit of measure during operations mode. Inserts a decimal point (.) when keying in values.

## Error Messages

The following are displays you may see if problems occur or if invalid operations are attempted with your WI-125:

Display	Description
	Overrange weight.
	Underrange weight.
	Recovering from lock-up or out of range condition.
	A-D converter is not functioning.
	Corrupted data in the reset menus. See the <i>Service Manual</i> . (* = RESET, SETUP, or CAL)
	Displayed while a key is pressed when attempting to modify a sealed selection without edit privileges.
	Device on serial port is not ready to receive data.
	User menu item is protected from changes by security code number.

# Indicator Operation

## Powering Up



### Attention

The socket-outlet must be installed near the equipment and easily accessible.

## Annunciators

The unit will power up in gross or net weighing mode, depending on what mode the unit was in when last turned off. All calibration, zero, gross and tare values will be maintained during power loss.

The indicator display, Figure 2, tells you the status of the indicator through the appearance of annunciators. In the LCD version, the annunciators are small arrows pointing to the different labels around the display face. In the LED version they are small labeled lights on the front panel.

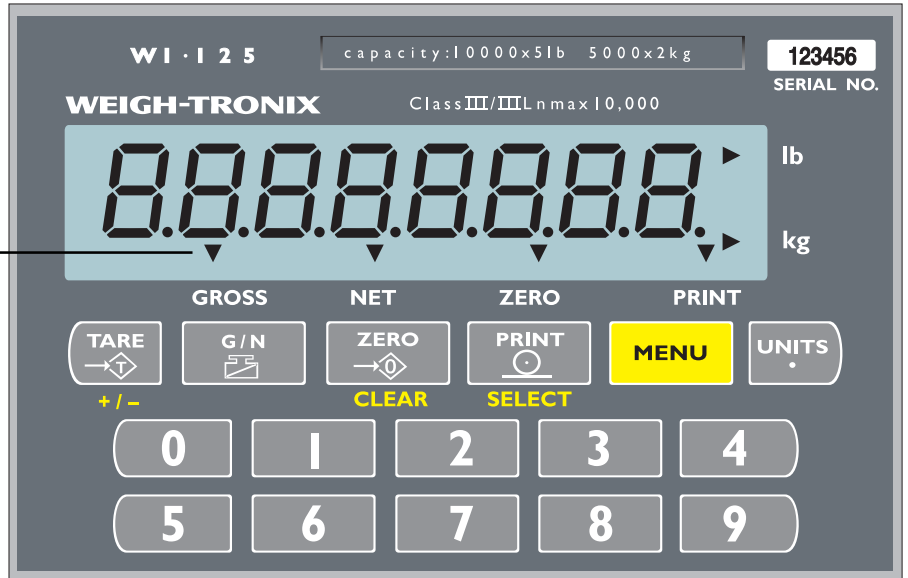

**Figure 2**  
Indicator Display (LCD version)

## Annunciators

No annunciators appear while motion is detected.

**Gross** - Appears when indicator is in gross weighing mode.

**Net** - Appears when a tare is in effect and the indicator is in net weighing mode.

**Zero** - Appears when the scale is within  $\pm 1/4$  division of zero.

**Print** - Appears when the print key is pressed and while data is transmitted.

**lb, kg** - Points out the active unit of measure in weighing mode.

## Gross / Tare / Net Weighing Operations

### Gross Weighing

To perform gross/net weighing operations, follow these steps:

1. Power up the indicator. Indicator powers up in gross or net mode.
2. If the unit is not in gross mode, press the **G/N** key once to get to gross mode. The annunciator illuminates next to gross. See Figure 2.
3. Verify the scale is empty and zero the scale by pressing the **ZERO** key. No weight is displayed and the zero annunciator illuminates. See Figure 2.
4. Select unit of measure by pressing the **UNITS** button. The units annunciator will point to the chosen unit of measure.
5. Place weight on the scale. Gross weight is displayed.

### Net Weighing

#### Pushbutton Tare

*You may view the current or active tare value at any time during a weighing process. From gross or net weighing mode, press **MENU**, TARE is displayed, then press **SELECT**. If a tare value is active, it will be displayed. If no tare value is active, NO TARE is displayed. Press **G/N** to return to gross/net weighing mode. Reference the Operations Menu section for menu details.*

For net weighing operations a tare needs to be entered. A tare can be entered by three methods: using the pushbutton tare, using quick keypad tare entry, or selecting a tare from the tare register (a memory bank of up to ten tares).

1. With the scale empty and the indicator powered up in gross mode, zero the scale by pressing the **ZERO** key. No weight is displayed and the zero annunciator illuminates.
2. Place the weight to be tared on the scale. The weight of the object is displayed.
3. Press the **TARE** key on the indicator. The weight is tared, the display reads zero and the net annunciator illuminates.
4. Add more weight to the scale. Net weight is displayed.
5. View the gross weight by pressing the **G/N** button. Gross weight is displayed and the gross annunciator illuminates.
6. Press the **G/N** key again to see net weight. Net weight is displayed and the net annunciator illuminates.



### Quick Keypad Tare Entry

1. From weigh mode, enter a tare value using numeric keys 0-9. Value is displayed as it is entered.
2. Push **TARE**. Net weight is displayed and the net annunciator illuminates.

### Selecting a Tare Register

*If you wish to scroll through all the tare registers, continue pushing **MENU**. Stop when the register you wish to use is displayed.*

Tare values must be entered in the tare registers before they can be used in weighing operations. Refer to the section "Entering and/or Changing Values in Tare Registers" at the bottom of this page.

1. From gross or net mode, press **MENU** once or twice, depending on options enabled, until . . . **tArE** is displayed.
2. Using the keypad, enter the number of the tare register you wish to use. (Numbers 0-9 are allowed.) That register with its tare value is displayed.
3. With the correct tare register displayed, press **G/N**. Tare value is displayed in net mode.

### Entering and/or Changing Values in Tare Registers

*Reference the Operations Menu section for menu details.*

1. With the gross or net annunciator illuminated, press the **MENU** button once or twice, depending on options enabled, until . . . **tArE** is displayed.
2. Using the keypad, enter the number of the tare register you wish to view. (Numbers 0-9 are allowed. For this example, tare register 5 will be used.) Key in numeral 5. The tare annunciator illuminates and the display shows **5 0**, indicating that register 5 has no value entered. (Your indicator may have a value in register 5.)

## Clearing a Tare Register

To set a tare register to 0, key in 0  
or  
empty the scale and press  
**TARE**.

3. You can enter/change a tare value in a register in two ways:

### 3A. Key in a tare value:

With the desired register number displayed, key in **155** for this example, then press **PRINT/SELECT**.

The value 155 is accepted and **tArE** is displayed.

or

### 3B. Use the pushbutton tare:

With the desired register number displayed and the container on the scale, press **TARE**.

The register number and (container weight) new tare value are displayed.

4. Press **MENU** to proceed to the next tare register.

5. Press **G/N** to return to the weighing mode.

The value is accepted, net weight is displayed and the net annunciator illuminates.

## Clearing the Active Tare

There are two ways to remove the current or active tare weight.

A. Remove all weight from the scale and press **TARE**.

The current active tare register is cleared, scale returns to gross mode and no weight is displayed.

B. 1. With the gross or net annunciator illuminated, press **MENU**, then press **CLEAR**.

**tArE** is displayed, then **no tArE** is displayed.

2. Press the **G/N** key.

Gross weight is displayed and no tare is active.

## Net Weighing Operation

1. After a tare is established, place the indicator in net mode by pressing the **G/N** key.

Net annunciator illuminates. Zero weight will be displayed with the container on the scale.

2. Place material to be weighed in the tared container on the scale.

Net weight of material is displayed.

## Entering Cutoff Values Through the Front Panel

Follow the steps below to enter a cutoff value. The cutoff output will be ON below the value entered and OFF equal to or over the value entered.

1. Push the **MENU** key until Cutoffs is displayed.
2. Push the **SELECT** key. . . Cutoffs 0 to 7 are displayed.
3. Push the **MENU** key to scroll through the cutoff channels.
4. Use the numeric keypad to enter the cutoff values then press the **MENU** or **SELECT** key.

## Controlling Cutoffs

The WI-125 Indicator allows you to control the cutoff process from the front panel. Through the WI-125 you may: enable/disable the cutoff process, continue or interrupt the operation of a cutoff before its setpoint has been reached, and/or terminate the process at any time before the last cutoff has been reached.

There are two types of cutoffs in the WI-125: the ingredient cutoff and the setpoint cutoff (default). With ingredient cutoffs, you tell the indicator the weight of each ingredient you want and the indicator will call for that much of each ingredient, no matter what the weight display says. If you want 100 pounds of ingredient #1 and 100 pounds of ingredient #2, you would enter 100 for cutoff #0 and 100 for cutoff #1.

With setpoint cutoffs, you tell the indicator at what weight display you want the cutoffs to activate. In other words, if you want 100 pounds of ingredient #1 and 200 pounds of ingredient #2, you would set the first setpoint cutoff at 100 and the second cutoff at 300 pounds because that is what the weight display will read when you want the actions to occur.

You can tell which kind has been configured in your indicator by looking at the cutoff number in the Operations menu shown below. If the cutoff number has a decimal **point** following it, the cutoff is a **setpoint** type. If there is no decimal, it is configured as an ingredient type.

*Some menu items may not appear in your particular situation due to configuration setup or firmware revision level.*

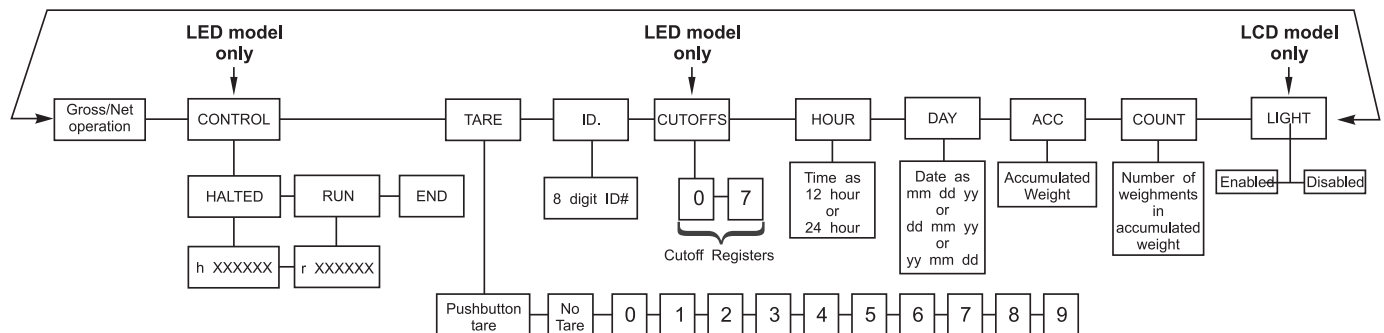

## To Access the Control Function

*Cutoff values (positive or negative) must be entered before you can control them.*

1. From Gross/Net Weighing Mode, press **MENU** one time. . . **Control** is displayed.
2. With Control displayed, press **SELECT**. . . **HALtEd** is displayed.

## To Activate and Control the Cutoffs

There are two ways--Methods A or B--to activate the cutoffs. Method A activates the cutoffs immediately while displaying the changing weight on the scale, and Method B allows you to view the weight on the scale before the cutoffs are activated.

### Method A:

1. With **HALtEd** displayed, press **MENU**. . . **run** is displayed.
2. Press **SELECT**. . . **r xxxxxx** is displayed. **xxxxxx** represents the weight as it changes on the scale.

### Method B:

1. With **HALtEd** displayed, press **SELECT**... **h xxxxxx** is displayed. **xxxxxx** represents the weight on the scale.
2. Press **MENU**.... **r xxxxxx** is displayed. **xxxxxx** represents the weight as it changes on the scale.

*To halt active cutoffs*

You may halt an active cutoff at any time.

With **r xxxxxx** displayed, press any key. . .

**h xxxxxx** is displayed and cutoffs are halted.

*To return to Gross/Net Weighing Mode*

You may return to G/N Weighing Mode at any time during this process by pressing **GROSS/NET**...

Display returns to G/N Weighing Mode.

## ID Number Entry

Reference the Operations  
Menu section for menu details.

You may enter an ID number of up to 8 digits in length. The ID number may include any combination of the numbers 0 through 9, a dash and a decimal point.

1. From gross weighing mode, press **MENU** repeatedly. . . . **id.** is displayed.
2. Press **SELECT** . . . The current ID number is displayed.
3. With the current ID number displayed, enter a numerical value for your ID number using the keypad. The new ID number is displayed.
4. After your new ID number has been displayed, press **SELECT**. . . **id.** is displayed.
5. Press **G/N** to return to the weighing mode. Display returns to gross or net mode.

## Viewing and Setting Time

Reference the Operations  
Menu section for menu details.

If you enter an incorrect digit,  
press **ZERO/CLEAR** to clear  
the display one digit at a time.

Your indicator must have the appropriate circuitry and be configured to allow the following:

1. From gross/net weighing mode, press **MENU** repeatedly until . . . . **Hour** is displayed.
2. Press **SELECT**. . . . In the 12 hour clock configuration you will see time displayed as hours, minutes and **A** for A.M. or **P** for P.M. (**09.40 A**). In the 24 hour clock you will see hours, minutes and seconds (**09.40.38**).
3. **To set the 12 hour clock**, use the numeric keypad to enter the correct time.
  - a. Key in the time as **hh mm**.
  - b. Press the **TARE** key to toggle between AM & PM.
  - c. After the correct time is entered, press **SELECT** to accept the new time. **Hour** is displayed and clock begins.
  - d. Press **G/N** to return to the weighing mode. Display returns to weigh mode.

**To set the 24 hour clock**, use the numeric keypad to enter the correct time.

  - a. Key in time as **hh mm ss**.
  - b. After the correct time is entered, press **SELECT** to accept the new time. **Hour** is displayed and the clock begins.
  - c. Press **G/N** to return to the weighing mode. Display returns to gross/net mode.

## Viewing and Setting the Date

*Reference the Operations Menu section for menu details.*

*If you enter an incorrect digit, press **CLEAR** to clear the display one digit at a time.*

Your indicator must have the appropriate circuitry and HOUR must be enabled and set correctly to allow the following:

1. From gross/net weighing mode, press **MENU** repeatedly until . . . **dAY** is displayed.
2. Press **SELECT**.  
Depending on the configuration of your indicator you will see the date displayed in one of three ways:
  - month-day-year, or
  - day-month-year, or
  - year-month-day.
3. To change the date, key in the new date using the numeric keypad.
4. Press **SELECT** to return to the operations mode menu  
The old date is replaced with the new date.  
or  
press **G/N** to return to gross/net weighing mode.  
The date is accepted and **dAY** is displayed.

## Single Accumulator with Counter

### Weighing and Printing

*Printing the accumulated weight and count can be accomplished at any time during the weighing process; however, printing these values automatically clears them from memory! So take care to print the accumulated values only after you have made all the necessary weighments.*

*A print/add function will occur if you have autoprnt enabled or if a remote Print command is received by the indicator.*

*WI-125 LED is configurable for LP02844 labels*

There is a single channel accumulator in both the LED and LCD model indicators. The accumulator will add the displayed weights automatically and print individual weights and totals on command.

1. Weigh load. . . Indicator displays weight.
2. Press **PRINT**. . . Weight is printed.
3. For each additional load weighed, press **PRINT**. . . Each weight is printed individually and the weight is totalled automatically within the indicator.
4. After the last load has been weighed and printed, press **MENU**, then **TARE**. . . The total weight and count are printed and cleared from memory.

```
G      210 lb
G      200 lb
G      200 lb
Count      3
Total     610 lb
```

### WP-233 Tape printer sample printout

10:00 AM 03-26-03

G 2974 lb  
T 1976 lb  
N 998 lb

**Sample 1**  
Orion 1 Label

10:00 AM 03-26-03

ID 125  
G 2974 lb  
T 1976 lb  
N 998 lb

**Sample 2**  
Orion 2 Label

10:00 AM 03-26-03

ID 125

G 2974 lb  
T 1976 lb  
N 998 lb

**Sample 3**  
Orion 3 Label

10:00 AM 03-26-03



ID 125



G 2974 lb



T 1976 lb



N 998 lb

**Sample 4**  
Barcode Label



The following label samples show the "Total" label available when using the ACCUM function in the LED version of the WI-125 indicator. See the ACCUM function.

10:00 AM 03-26-03  
C 2  
T 5948 lb

**Sample 5**  
Orion 1 "Total"  
Label

10:00 AM 03-26-03  
Count 2  
Total 5948 lb

**Sample 6**  
Orion 2 "Total" Label

10:00 AM 03-26-03  
Count 11  
Total 22757 lb

**Sample 7**  
Orion 3 "Total" Label

10:00 AM 03-26-03  
C 2  
T 5948 lb

**Sample 8**  
Barcode "Total" Label

## Viewing Accumulated Weight and Count

**GROSS** may be pressed at any time during viewing to return to weighing mode.

1. With weight displayed, press **MENU** until. . . **ACC** is displayed.
2. Press **PRINT/SELECT**. . . Total weight of all loads is displayed.
3. Press **PRINT/SELECT** to toggle back to **ACC**. . . **ACC** is displayed.
4. Press **MENU** once. . . **count** is displayed.
5. Press **PRINT/SELECT**. . . Total number of loads is displayed.
6. Press **PRINT/SELECT** to toggle back to count. . . **count** is redisplayed.
7. Press **G/N** to return to weighing mode. . . Current weight is displayed.

## Enabling or Disabling Display Backlight

Backlight available on LCD version only.

Configuration choice (ON/OFF/AUTO) made during setup of this unit will determine if the backlight is on constantly or if it varies according to ambient light levels. Refer to the Service Manual.

- From gross/net weighing mode, press **MENU** repeatedly until . . . **Light** is displayed.
  - Press **SELECT**. **ENABLED** or **diSAbLEd** is displayed
  - Press **MENU** to toggle between enabled or disabled.
  - Press **SELECT** to return to the operations mode menu  
or  
press **G/N** to return to gross/net weighing mode.
- The light selection is accepted and **Light** is displayed.
- The light selection is accepted and the display returns to gross/net mode.

## Operations Menu

Your WI-125 SST may be configured to display some or all of the following functions: tare, id, time, date, accumulator, count, and backlight. These can be viewed and changed if allowed by the security code. **This manual assumes the unit is configured to allow full access to all functions.** You can disable unneeded options. Instructions are in the *Service Manual*.

Below is a flowchart and general instructions for moving around the operations mode menu. The instructions in the preceding sections outlined the steps in detail for moving around in this menu. Use this flowchart as a quick reference to maneuver through the operations mode menu.

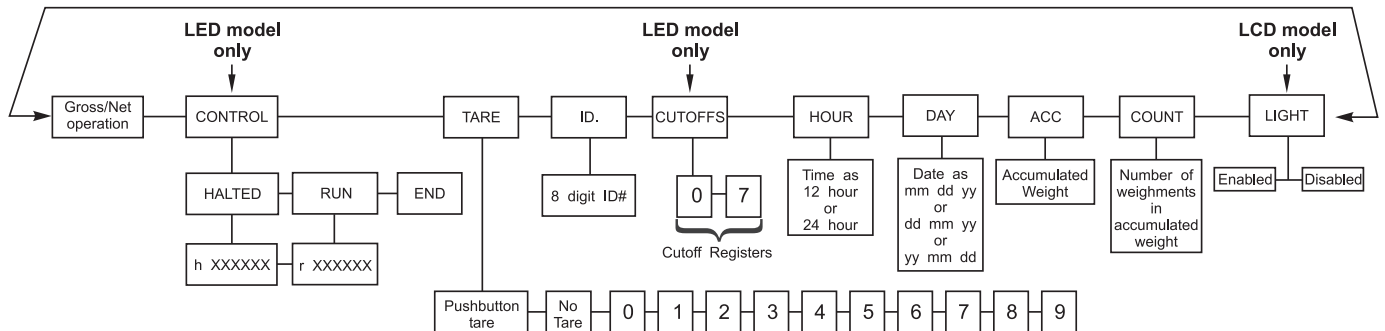

**Figure 3**  
Operations Menu

- Press **MENU** to move → in the diagram
- Press and hold **MENU** for 1.5 seconds to move ← in the diagram
- Press **PRINT/SELECT** to move ↓ in the diagram
- Press **PRINT/SELECT** for 1.5 seconds to select new choice and move ↑ in the diagram
- Press **G/N** at any time to save changes and return to gross/net weighing mode

# Indicator Diagnostics

## Test Mode

The test mode is used to test various functions of the WI-125. The test menu is shown in Figure 4. Instructions for using the test menu are found below.

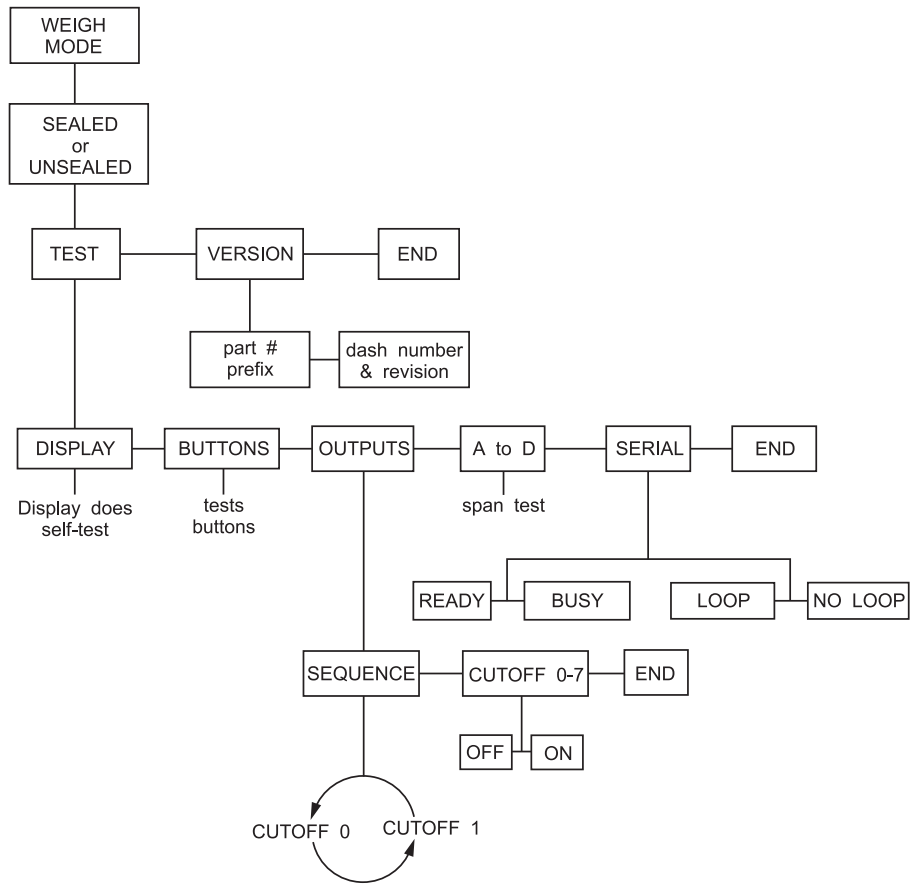

**Figure 4**  
Test Menu

Press **MENU** to move → in the diagram

Press and hold **MENU** for 1.5 seconds to move ← in the diagram

Press **PRINT/SELECT** to move ↓ in the diagram

Press **PRINT/SELECT** for 1.5 seconds to select new choice and move ↑ in the diagram

Press **G/N** at any time to save changes and return to gross/net weighing mode

1. Enter the test mode from gross/net operation by pressing and holding the **MENU** key until **tESt** is displayed. **SEALED** or **unSEALED** is displayed briefly while you hold the key. If you release the **MENU** key too soon, press **G/N** to return to normal weigh mode and begin again.
2. Move to the right through the menu selections by pressing **MENU** briefly. Move to the left through the menu selections by pressing **MENU** for 1.5 seconds or hold down for continuous scrolling.

3. To move down a level in the hierarchy, press **SELECT**. Anytime you wish to get to the next higher level in the hierarchy, press and hold **SELECT** for approximately 1.5 seconds or press **SELECT** whenever **End** is displayed.
4. Press **MENU** to toggle between choices.
5. Press **G/N** to return to gross weighing operation at any time.

Below are the specific directions and explanations for the items you see in the test menu.

- VERSION — Under *VERsION* are the Weigh-Tronix part number and revision number for the software found in your machine. Weigh-Tronix part numbers are divided into two parts: the prefix and the dash number. With *VERsION* displayed, press **SELECT** to view the prefix, then push **MENU** to view the dash number. Press **SELECT** to return to *VERsION*.
- DISPLAY — With *diSPLAY* displayed, press **SELECT** and the bottom row of annunciators turns on. Press **SELECT** again and a dynamic test is run. Press **MENU** to stop the dynamic test or consecutively press **MENU** to step through the display test routine. Press **SELECT** when the dynamic test is active to return the unit to *diSPLAY*.
- BUTTONS — With *buttonS* displayed, press **SELECT** and an underscore will appear on the screen. Press any key except **MENU** to check for proper key functioning. After testing the buttons, press **MENU** to return to the display.
- OUTPUTS — These tests allow you to turn the cutoffs on and off automatically in sequence, under *SEQUENCE*, or individually, under *CUTOFF 0-7*. When you exit the outputs test, the cutoffs revert to their proper condition according to the weight on the scale.
- A to D — Displays the analog to digital counts. The span is normally 20000 counts per millivolt per volt. With a calibrator at zero millivolts per volt, the displayed value should be between -200 and +200. Press **SELECT** to return to A to D.
- SERIAL — Tells you if the serial output is ready or busy. A jumper connecting pins DTR to CTS of the serial port will cause *REAdY* to be displayed. Pressing the **MENU** key puts *no LOOP* on the display. With pins XMITT to RECV connected, *LOOP* is displayed. With them disconnected, *no LOOP* is displayed. Press **SELECT** to return to *SErIAL*.

## RS-232 Output

The WI-125 SST provides an RS-232 output for data transmission to a peripheral device. Refer to the Service Manual for RS-232 interface connections.

### To transmit data, follow these instructions:

If your indicator has a peripheral device connected, from the gross/net weighing mode press the **PRINT** key to transmit the selected output(s).

The **PRINT** annunciator (See Figure 2) will illuminate while data is transmitted and the data configured to be printed will be output to the printer. See Figure 5 for a sample printout.

### Communication protocol

Samples of the default printout for a WI-125 SST are shown in Figure 5. This is the displayed weight (Gross or Net) followed by a carriage return and line feed.

An enquire code can be sent to the WI-125 SST. This will prompt the indicator to send a standard printout. The default enquire code number is an ASCII decimal 005. This number can be changed in configuration.

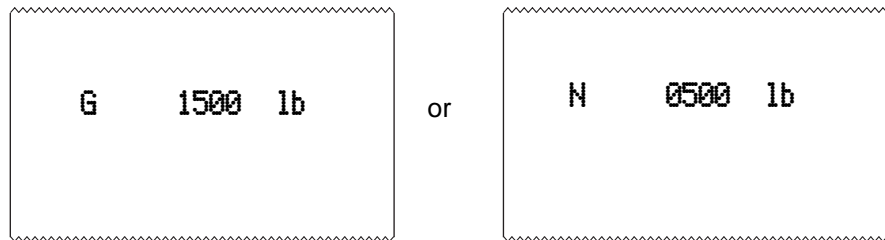

**Figure 5**

The default settings for serial output are:

Busy	Disabled
Baud	1200
Parity	Clear = 8 data, no parity
Stops	1

	Stop Bits	Data Bits	Parity
NONE	1 or 2	7 or 8	None
ODD	1 or 2	7	Odd
EVEN	1 or 2	7	Even
SET	2	7	None
CLEAR	1	8	None



# Avery Weigh-Tronix



## **Avery Weigh-Tronix USA**

1000 Armstrong Dr.  
Fairmont MN 56031 USA  
Tel: 507-238-4461  
Fax: 507-238-4195  
Email: [usinfo@awtxglobal.com](mailto:usinfo@awtxglobal.com)  
[www.wtxweb.com](http://www.wtxweb.com)

## **Avery Weigh-Tronix UK**

Foundry Lane,  
Smethwick, West Midlands,  
England B66 2LP  
Tel: +44 (0) 8453 66 77 88  
Fax: +44 (0)121 224 8183  
Email: [info@awtxglobal.com](mailto:info@awtxglobal.com)  
[www.averyweigh-tronix.com](http://www.averyweigh-tronix.com)