



## B801 series Service manual

1phase 220V-240V 0.5HP-3HP

3phase 220V-240V 1HP-10HP

3phase 380V-440V 1HP-10HP



---

## Category

1. Preface .....	3
2. Notes for safe operation.....	3
3. Inspection checkpoints	
3.1 Check procedure.....	4
3.2 Model explanation.....	4
4. Installation	
4.1 Exterior size .....	5
4.2 Operating environment .....	6
4.3 Notice .....	7
5. Wiring	
5.1 Connection diagram .....	8
5.2 Notes for operation.....	9
6. Keyboard Operation	
6.1 LCD and operation key .....	9
6.2 Utility of operation key .....	10
7. Test run operation.....	10
7.1 Master some relevant functions which may let you acquire more ideal use effects .....	10
7.2 Keyboard operation mode .....	11
7.3 Keyboard operation for FOR/REV.....	11
7.4 Terminal control mode .....	13
7.5 Parameter resume ex-work value .....	13
7.6 Saving condition after parameter modification .....	14
8. The symbol explanation on LCD .....	15
9. Parameter and data sheet	
9.1 Parameter list .....	15
9.2 Parameter explanation.....	21
10. Fault diagnosis and corrective actions	
10.1 Notes for remedy once fault detects .....	28
10.2 Troubleshooting .....	29
10.3 Notes during operation.....	30
11. B800-200V series standard specification .....	31
12. B800-400V series standard specification .....	32

## 1. Preface

Thanks for your choose B801 series high functional frequency inverter, please read this manual carefully before use.

## 2. Notes for safe operation

Frequency inverter is a latest product for electric and electronic. To guard your safety, there are signals both “danger” and “notice” in this manual to remind you some safety precaution notices when movement, installation, operation and check.

**! DANGER**

Misuse may cause casualty.

**! NOTICE**

Misuse may cause damage to inverter or system.

### DANGER

- Please don't take down, alter! Otherwise, it may cause electric shock, fire and injure.
- Don't open the cover during electrify
- Don't put or insert wire, stick and filament etc. into inverter to avoid short circuit or electric shock.
- Please don't splash water or other liquid onto inverter.

### NOTICE

- Please don't perform a withstand voltage testing to the components of inverter.
- Absolutely don't connect output terminal (U, V, W) with AC main circuit power supply.
- Components CMOS IC on circuit board are easily affected and damaged by static electricity, please don't touch it casually.
- Electromotor and inverter should fit to the matched AC power; Otherwise, it may cause operate abnormality, even burn.

### 3. Inspection checkpoints

#### 3.1 Check procedure

- a) Make sure inverter is same as you purchase.
- b) Make sure inverter is in good condition which don't get damaged during transportation; if damaged, please don't connect with AC main power.
- c) Make sure the S/N on warranty is same as inverter.

Please inform our salesperson ASAP if you find the above problems.

#### 3.2 Model explanation

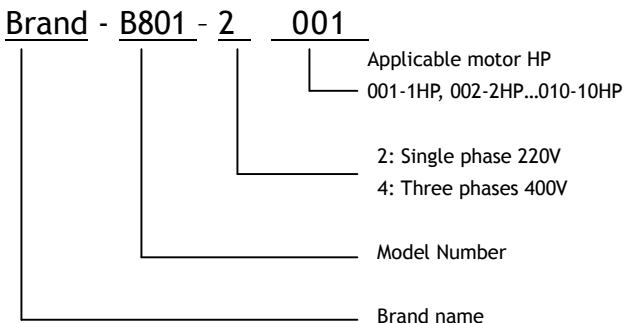

## 4. Installation

### 4.1 Exterior Size

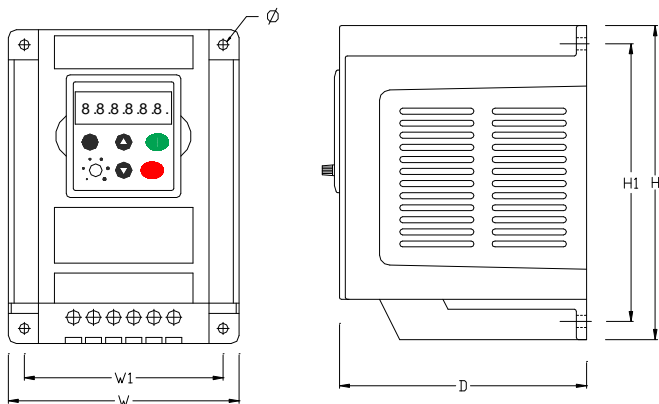

Unit: mm

400V	1-2HP	3-5HP	7-10HP
200V	1-2HP	3-5HP	7-10HP
H	165mm	214mm	255mm
H1	150mm	200mm	241mm
W	120mm	151mm	180mm
W1	107mm	135mm	164mm
D	123mm	160mm	180mm
$\Phi$	5mm	6mm	6mm

### 4.2 Operating environment

To ensure proper performance and long operation life, Follow the recommendations below when choosing a location for installing B800 series frequency inverter, Make sure the B801 series frequency inverter is protected from the following conditions

- . Ambient temperature: hanging type,  $-10\sim 45^{\circ}\text{C}$   
 Tank closed type,  $-10\sim 40^{\circ}\text{C}$ .
- . Rain, Moisture (For enclosed wall-mounted type)
- . Oil fog, salt spray
- . Direct sunlight.(Avoid use outdoors)
- . Corrosive gases or liquid
- . Dust or metallic particles in the air.
- . Physical shock, Vibration
- . Magnetic noise (Example: welding machine, power devices etc)
- . High humidity
- . Radioactive materials
- . Combustibles: thinners, solvents, etc.
- . If few inverters are mounted into cabinet, Please kindly put them on ventilated position where the good ventilation is available. Further to mount the cooling fan inside the cabinet to make the ambient environment under  $45^{\circ}\text{C}$
- . Sufficient mounting space within below stipulation

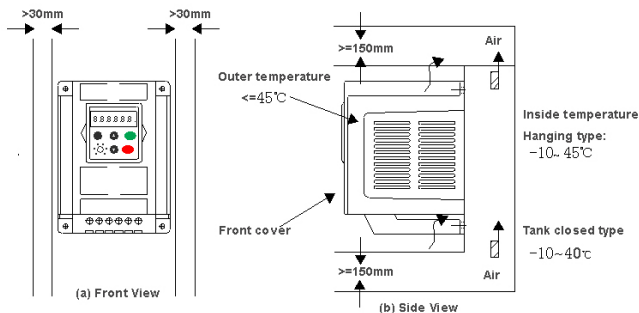

### 4.3 Notice



#### Notice

- Please don't hold the front cover when move, the right way is to hold the heatsink of inverter so as to avoid falling down which could injury person or damage inverter itself.
- Please mount inverter onto nonflammable materials like metal and other else; please don't mount it nearby nonflammable materials to avoid fire.
- If few inverters are mounted into a controlling cabinet, cooling fan must be mounted inside cabinet to ensure temperature of cabinet inside is lower than 45°C to avoid overheat.
- Please cut off AC main power until LCD off prior to remove keyboard.
- Carry on the wiring or check inside of AC drive only after cut off main AC power supply 2 minutes later, Otherwise, it may be electric-shocked

## 5. Wire

### 5.1 Connection diagram

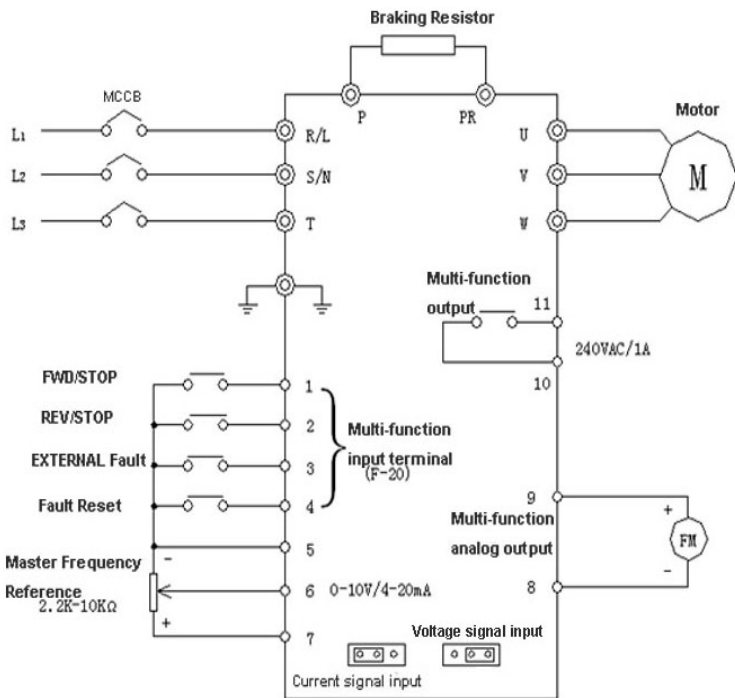

Note: 1. three phases 400V use R/L, S/N, T as AC main power input terminal,  
Single phase 220V only uses R/L and S/N.

2. There are not inbuilt braking resistors both of single phase 220V/1hp-2hp & three phase 400V/1hp-2hp among standard configuration. If need, pls. contact with us while purchasing, we



should inbuilt it inside free.

3. B800 Series inverter default as keyboard control (F-13=3), it will work after AC main power input
4. Default value between terminal 5 & 6 is analog voltage signal input (short circuit socket put on the right side), when the analog signal input is current signal (F-17=3,4,5), Pls. put the short circuit socket on the left side.

### **5.1.2 Connection between inverter and fitting parts**

- (1) Must assemble disjunction device such as isolation switch etc. between power source and the inverter to assure personal safety when repairing the inverter and needing compulsory power off.
- (2) Power supply loop must have breaker or fuse with over current protection function to avoid malfunction expanding caused by failure of after device.
- (3) AC input reactor

If high-order harmonics between inverter and power supply is biggish which can't fulfil system requirement, or need to improve input side power factor, AC input

reactor is needed.

(4) Magnetic control conductor only be applied to power supply control and don't apply magnetic control conductor to controlling on/off of the inverter

(5) Input side EMI filter  
Can use EMI filter to inhibit high-frequency conduction disturbance and emission disturbance from inverter power supply wire.

(6) Output side EMI filter  
Can use EMI filter to inhibit emission disturbance noise and wire leakage current from output side.

(7) AC output reactor  
Advise assembling AC output reactor to avoid motor insulation damage, too large over current and inverter frequent protection when connecting wire from inverter to motor exceeds 50m. But voltage drop of AC output reactor must be considered. Improve input output voltage of the inverter or let the motor in lower volume to avoid burning off the motor.

(8) Complete ground wire  
Inverter and motor must be earthed and grounding resistor smaller than 10 .Grounding wire should be shorter enough and wire diameter be bigger enough(not smaller than following standard):

7.5KW or below motor: 3.5mm<sup>2</sup> above copper wire

11KW motor: 8mm<sup>2</sup> above copper wire.

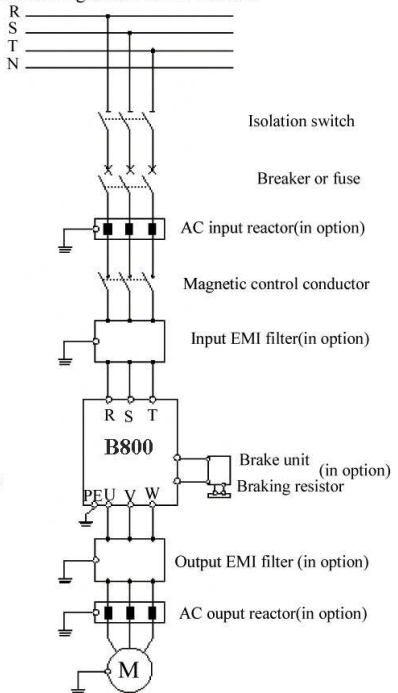

connection of inverter and fitting parts

## 5.2 Notes for operation







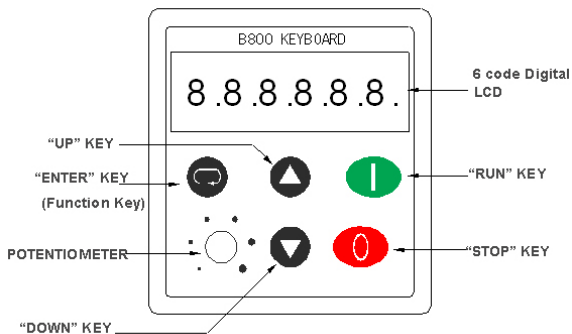

- Parameter F-01 can be set as Max.30000 rpm/Min. of motor, please use this parameter with care.
- If user wants to operate the RPM of motor higher (F-01/F-09 parameter) than the rated rotate speed of motor, please confirm the allowable range between the motor and machinery.
- The cooling fan of inverter would automatically start to work once the temperature reach 40°C, and would stop working when its temperature is under indoor.
- Please attention other relevant settings once use braking resistor.
- Please don't check the signal on PCB when inverter is running.
- Parameters have already been set when ex-work, please don't adjust it casually.

## 6. Keyboard Operation

### 6.1 LCD and operation Key



## 6.2 Utility for operation key

- When inverter ex-work, standard parameters are set as default.
- Press “Enter” key  one second, then enter into check/modify standard parameter group.
- Press  or  key to check the parameter group from F-01 to F-52
- Press “Enter” key  again, which can read parameter value.
- Press  or  key, modify parameter value.
- Press “Enter” key  again, Back to parameter group.
- If press “Enter” key  more one second or standby more 20 seconds,  
Back to initial status prior to standard parameter group modification
- If want to enter into extended menu access(F-16-F-52), set F-15 to “10”, and press “Enter” key .

## 7. Test operation

7.1 Master some relevant functions which may help you acquire more ideal use effects

- Maximum and minimum output frequency F-01&F-02.  
The maximum and minimum speed limitations are set according to actual individual requirements.
- Accelerate and decelerate parameter F-03&F-04.  
If linear acceleration time and linear deceleration time too short on some occasions, which may cause drive over-current

and let drive trip, which cause motor stop working.

- Stop mode F-05.

When F-05=0, inverter would diminish motor's speed according to linear deceleration time we set.

If F-02≠0, when inverter start, motor would accelerate from mini frequency we set (F-02), when inverter stops work, the motor linear decelerate to '0' and then stop work.

If user want the motor stops work automatically (inertia stopping), please sets F-05 to 1.

- V/F curve select F-06.

General loading F-06=0.

Such as fan, water pump etc. which are belonging to variable torque loading. Set F-06=1, which will reduce the energy wastage when motor run at low speed.

- Motor rated current, rated frequency and rated RPM (F-08, F-09, F-10).

Parameters should be set according to the nameplate on the motor

- Low speed voltage compensation (F-12).

Favorable to start motor smoothly, Maximum value of voltage compensation up to 28%.

- Controlling methods select (F-13).

Terminal controlling method is for long distance control use.

Keyboard controlling method is for trial running or handle manually.

- "Extended menu access" select(F-16-F-52)

"Extended menu access" is designed for inverter application experts, engineers or technicians. General users don't need to use it.

## 7.2 Keyboard operation mode

- Press “Run” Key ①, LCD appear to H0.0.
- Press “UP” Key ▲, frequency output increase.
- Press “DOWN” Key ▼, frequency output descends.
- Press “STOP” Key ①, inverter stop frequency output, LCD appears to stop.

## 7.3 Forward/Reverse operation on Keyboard

- Set F-13=2.
- Press “RUN” Key ①, LCD appears to H0.0.
- Press ▲ key, Speed increase.
- Press “RUN” Key ① again, Change motor rotary direction.
  
- Set Parameter F-13=3
- Press “RUN” Key ①, LCD appears to H\*\*\*.\*
- Turn the potentiometer as clockwise to increase speed
- Turn the potentiometer as anti-clockwise to descend speed
  
- Set Parameter F-13=4
- Press “RUN” Key ①, LCD appears to H\*\*\*.\*
- Turn the potentiometer as clockwise to increase speed
- Turn the potentiometer as anti-clockwise to descend speed
- Press “RUN” Key ① again, Change motor rotary direction

## 7.4 Terminal controlling operation mode

- Parameter F-13=0 (Control terminal operation mode)
- Connect the start/stop switcher among terminal 1,2 and 5.
- Connect one potentiometer (2.2K $\Omega$ -10K $\Omega$ ) among terminal 5, 6 and 7

When F-20=0 means two-wire initialization controlling, Terminal 1, 2 stand for Forward Start/Off switcher and Reverse Start/Off switcher respectively.

- When “Start/Off” switcher ON, Turn potentiometer to change output frequency (HZ) to make the motor rotary
- When “Start/Off” switcher OFF or turn potentiometer to “0”, Inverter stop work

When F-20=1 means three-wire initialization controlling, Terminal 1 stand for “Start” Switcher, Terminal 2 stand for “For/Rev” switcher, Terminal 4 stand for “Stop” switcher.

## 7.5 Parameters resume default (Parameters reset)



- When inverter stop and appear “Stop” on LCD, simultaneity press  $\blacktriangle$ ,  $\blacktriangledown$  and “Enter” Key  $\textcircled{0}$  1 second
- LCD appears P-SET, which means all parameters have resumed to default (ex-work value).
- Press “Enter” Key  $\textcircled{0}$  again, LCD appears “Stop”.
- Parameter F-45 would restore to 10, but F-47 and F-14 not be effected.

## 7.6 The saving condition after parameter modification

- As F-46=0 (Default value), all parameters could be modified, and they would be saved in EEPROM when AC main power is cut off.
- As F-46=1, all parameters could be modified, but they would not be saved in when AC main power is cut off.
- As F-46=2, all parameters couldn't be modified, read only.

### Notice

To prevent other persons modify parameters causally, please select any number among 0 to 3999 for parameters F-45 (enter into "Extended menu access" password).

- Under status of "Extended menu access (monitor)", LCD would return to initial status if without any operation within 20 seconds.
- when enter into the status of monitor, LCD would return to initial status if without any operation over 60 seconds.
- Press  Enter Key over 1 second, we can switch the status between monitor mode and Parameter F-01, when we switch to monitor mode, we can use UP  and DOWN  Key to read the relevant parameter contents



## 8. The symbol explanation on LCD

Symbol on LCD	Explanation	Symbol on LCD	Explanation
H50.00	Frequency output 50HZ	d 300	DC bus voltage 300VDC
L50.00	Remote control terminal set frequency 50.00Hz	t 345	Interior thermal resistor value
P50.00	Keypad potentiometer set frequency 50.00	n 1350	RPM 1350
F50.00	Keypad Up and down key set frequency 50.00	r 1.05	Motor slip 1.05Hz
A4.5	Output current 4.5A	Stop	Drive stop work
U300	Motor output voltage 300VAC	F-01	Parameter F-01
Radix Point twinkling	Drive overload	P-SET	Resume default value

## 9. Parameter and datasheet

### 9.1 Parameter list

#### STANDARD PARAMETER

Par.	Description	Range	Default
F-01	Maximum speed	F-02 to 500Hz	50Hz
F-02	Minimum speed	0 to F-01 (max 500Hz)	0Hz
F-03	Linear Accel time(s)	0.1 to 3,000s	5s
F-04	Linear Decel time(s)	0.1 to 3,000s	5s

F-05	Stop mode select	0, 2: linear stop (ramp stop) 1: inertia stop (coast to stop)	0
F-06	V/F characteristic	0: Constant torque, 1: Variable torque	0
F-07	Rapid linear Decel time (s) when power cut off	0.0 to 25s. (Disabled when 0.0s)	1.0s
F-08	Motor rated current	Motor rated current * (10% to 100%)	100%
F-09	Motor rated frequency	0Hz to 500Hz	50 Hz
F-10	Motor output voltage	0-100% of motor rated output voltage	90%
F-11	Motor pole pairs	0,1,2,3,4,5	2
F-12	Voltage boost	0 to 28% of max output voltage	6%
F-13	Terminal or Keypad control select	0: Terminal control 1: keyboard control-Fwd only ▲, ▼ control speed 2: keyboard control-Fwd/Rev ▲, ▼ control speed 3: keyboard control-Fwd only Potentiometer control speed 4: keyboard control-Fwd/Rev Potentiometer control speed 5: Reserve (Modbus RS485 ) 6: Potentiometer control speed, Terminal control Start/Stop 7. ▲, ▼ control speed Terminal control Start/Stop 8. Terminal control speed Keyboard control Start/Stop	3
F-14	Trip log	Last four trips stored	Read only
F-15	Extended menu access	Code 0 to 3999	0

**EXTENDED PARAMETER Menu**

F-16	Drive Capacity	0~13	Read only
F-17	Analog input format (V/mA)	Voltage: 0: 0V-10V, 1: 10V-0V 2: -10V-10V Current: 3: 4-20mA 4: 0-20mA 5:20-4mA	0
F-18	Carrier wave selection	0:2KHz 1:4KHz 2:8KHz 3:12KHz 4:15KHz	1
F-19	Multi-function terminal output selection	0: Drive enabled 1: Drive fault or External trip 2: At set speed 3: motor stop (Speed =zero) 4: Motor at max speed (F-01) 5: motor healthy	1
F-20	Multi-function terminal input selection	0 to 7	0
F-21	Multi-stage speed 1	-F-01 (reverse) to F-01(Forward)	5.0Hz
F-22	Multi-stage speed 2	-F-01 (reverse) to F-01(Forward)	0.0Hz
F-23	Multi-stage speed 3	-F-01 (reverse) to F-01(Forward)	0.0Hz
F-24	Multi-stage speed 4	-F-01 (reverse) to F-01(Forward)	0.0Hz
F-25	Multi-stage speed 5	-F-01 (reverse) to F-01(Forward)	0.0Hz
F-26	Multi-stage speed 6	-F-01 (reverse) to F-01(Forward)	0.0Hz
F-27	Multi-stage speed 7	-F-01 (reverse) to F-01(Forward)	0.0Hz
F-28	Multi-stage speed 8	-F-01 (reverse) to F-01(Forward)	0.0Hz
F-29	Slip compensation	0% to 110% of rated Slip	0%
F-30	Analog output function	0:output frequency(motor speed) 1:Ouput current 2:Drive enabled 3:Given frequency	0

## B801 Series frequency inverter user manual

F-31	Skip freq /speed	0 to F-01 (max)	0Hz
F-32	Skip freq /speed band	(0 – 100%)* F-09	0Hz
F-33	V/F characteristic curve Mid. Frequency 1	0 to F-09 (0Hz disable)	15Hz
F-34	V/F characteristic curve Mid. Frequency 1 (correspondent voltage)	0 to 100%	29
F-35	V/F characteristic curve Mid. Frequency 2	F-33 to F-09	25Hz
F-36	V/F characteristic curve Mid. Frequency 2 (correspondent voltage)	F-34 to 100%	42
F-37	Drive start mode	0: Start when terminal ON  1: If terminal is under ON status before electrify, inverter can not be started; Pls. put the terminal OFF first, and then “ON”, the motor start.	1
F-38	DC injection voltage	0 to 22% of max voltage	16%
F-39	DC injection braking time when stop	0 to 250.0s	0s
F-40	DC injection braking time before start	0 to 250.0s	0s
F-41	DC injection select	0: Inactive 1: Enabled	0
F-42	Braking resistor function select	0: Disable 1: Enable 2: Enable with overload protect	1
F-43	Frequency instruction adjustment factor	0 – 1100	1065
F-44	Analog input bias	0 to 1000	180
F-45	Enter “Extended menu access” code	0 to 3999	10

## B801 Series frequency inverter user manual

F-46	Parameter access lock	0: Parameters can be changed, auto-save when power cut off 1: Parameter changes not saved When power cut off 2: Read-only. No changes allowed.	0
F-47	Hours run meter	0 to 9999 hours	Read only
F-48	PID samples cycle	0.1S-400.0S	0.2
F-49	PID proportional factor	0.1-400.0	0.1
F-50	PID integral constant	1-3999(0 integral disable)	100
F-51	Analog output gain	0% to 500%	90
F-52	Jog frequency	0-50Hz	10

### Parameter explanation to only-read window

Parameter No.	Monitor content explanation	Set Range	Default
	H: output frequency	HZ	
	L: Terminal analog setting frequency	HZ	
	P: Keypad analog setting frequency	HZ	
	F: Keypad Up & Down key setting freq.	HZ	
	A: Drive output current	A	
	U: Motor Voltage	VAC	
	d: DC bus voltage	VDC	
	t: Interior thermal resistor (NTC) Value	0~1023	
	n: motor rpm display	RPM	
	r: Motor slip display		

## Multi-function Contact input menu

F-20	Multi-function contact 1	Multi-function contact 2	Multi-function contact 3	Multi-function Contact 4
0	Open: Stop Close: FWD	Open: Stop Close: REV	Open: NO Close: External trip input	Open: NO Close: Trip reset
1	Open: NO Close: RUN	Open: FWD Close: REV	Open: External trip input Close: NO	Open: Stop Close: NO
2	Open: STOP Close: RUN	Multi-stage speed 1	Multi-stage speed 2	Multi-stage speed 3
3	Open: STOP Close: PID Enable	Open: FWD Close: REV	Open: External trip input Close: NO	Open: NO Close: Trip reset
4	Open: Stop Close: Run	Open: FWD Close: REV	Open: External trip input Close: NO	Open: NO Close: Trip reset
5	Open: STOP Close: FWD	Open: STOP Close: REV	Open: External trip input Close: NO	Open: NO Close: Trip reset
6	Open: STOP Close: RUN	Open: External trip input Close: REV	Combined reference 1	Combined reference 2
7	Open: FWD STOP Close: FWD	Open: REV STOP Close: REV	Open: Analog input Close: Jog	Open: External trip input Close: NO

- We define FWD as motor rotary along clockwise direction

- When F-20=0 which means two-wire initialization controlling, analog input signal specification can be set through parameter F-17. when Terminal 3 close which means external trip input, LCD appears “IN-Fit”.
- When F-20=1 which means three wires initialization controlling, Terminal 1 is for START, Terminal 2 is for FWD/REV, Terminal 4 is for STOP, the type of analog input signal is set by F-17

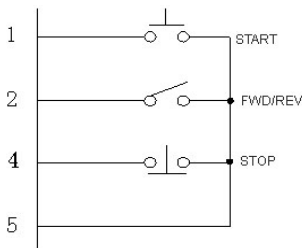

3 Wire system controlling diagram

- When F-20=2 which means multi-stage speed controlling, Terminal 1 is for START/STOP

Preset speed	Terminal 2	Terminal 3	Terminal 4	Speed given
1 <sup>st</sup> Speed	Open	Open	Open	F-21
2 <sup>nd</sup> Speed	Close	Open	Open	F-22
3 <sup>rd</sup> Speed	Open	Close	Open	F-23
4 <sup>th</sup> Speed	Close	Close	Open	F-24
5 <sup>th</sup> Speed	Open	Open	Close	F-25
6 <sup>th</sup> Speed	Close	Open	Close	F-26
7 <sup>th</sup> Speed	Open	Close	Close	F-27
8 <sup>th</sup> Speed	Close	Close	Close	F-28

- When F-20 =3, Contact terminal 1 is for PID control, Feedback value input from terminal 6 and terminal 5, Target value is set from the keypad

- When F-20 =4, if F-13=1, 2,3,4 (Keypad local controlling mode), FWD/REV is controlled by terminal 2, Keypad control “Start/Stop” & control speed.
- When F-20 =5, terminal 1, 2, 4 is same as the function when F-20=0, The type of analog input signal is set by F-17, when terminal 3 open which means external trip input.
- When F-20 =6, Terminal 1 control “Start/Stop”; Terminal 2 is normal Close (N.C), if Open that is for external trip input; Terminal 3 & 4 is for combined reference, Combined reference as below:

Multi-function contact 3	Multi-function Contact 4	Action
OPEN	OPEN	External analog input
CLOSE	OPEN	Multi-speed 5 (F-25)
OPEN	CLOSE	Multi-speed 4 (F-24)
CLOSE	CLOSE	Multi-speed 7 (F-27)

- When F-20 =7, terminal 1 & 2 control the rotary direction (FWD/REV); if terminal 3 Open that is for external analog input, Close is for Jog running; Terminal 4 Open is for external trip input.

Note: 1)If contact terminal 1 & 2 Close at the same time, Software default it as operation error--Inaction.

2) Jog reference is prior to other references, which given by F-52



## 9.2 Parameter explanation

### Standard parameter group

#### •F-01 max output frequency

Maximum frequency limitation

#### •F-02 min output frequency

Minimum frequency limitation

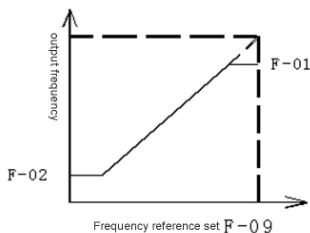

#### •F-03 linear Accel time(S).

The required time accelerate from 0HZ to 50HZ.

#### •F-04 linear Decel time(S).

The required time decelerate from 50HZ to 0HZ

#### •F-05 stop mode select

0: Decelerate and stop according to parameter F-04;

2: Decelerate and stop according to parameter F-07;

1: Get “Stop” instruction, Drive stop output.

motor coast to stop(inertially).

#### •F-06 V/F characteristic curve select.

(A) Relation between voltage and frequency.

Pls.refer to picture: 0 curve is constant torque,

1 curve is variable torque.

(B)Through adjust the parameter F-33,F-34,F-35,F-36,V/F curve can be further changed as below picture

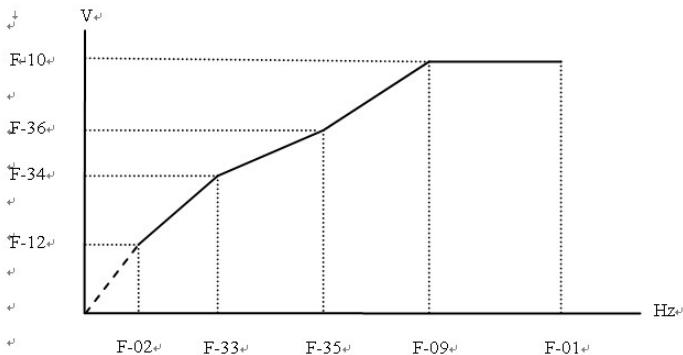

- **F-07 Decelerate time when power cut off.**

Linear deceleration time (F-05=2) when AC main power cut off. (Refer to F-07).

- **F-08 motor rated current**

Motor rated current = Drive rated current \* (10%-100%). When the capacity of drive is over motor capacity, properly adjust Parameter F-08 can avoid motor run with overload

- **F-09 motor rated frequency.**

The rated current value marks on the nameplate of motor, Pls. input the parameter as per motor rated frequency on the nameplate; Otherwise, it maybe cause both motor and AC drive damaged. if parameter F-09 be changed, pls. reset parameter F-33 and F-35 to make sure F-09>F-35>F-33; Otherwise, AC drive parameter would be resumed to default value

• **F-10 motor output rated voltage**

Correspondence output voltage of rated RPM (%). If Parameter F-10 be change, pls. reset parameter F-36.F-34.F-12 to make sure  $F-10 > F-36 > F-34 > F-12$ .

**Note: when the parameters we set do not satisfy with the above relationship, AC drive parameter would be resumed to default value**

• **F-11 Motor pole pairs**

For example: Motor rated frequency is 50HZ, RPM range can be set from 600-3000RPM/min. It just for display the RPM used.

When  $F-11 \neq 0$ , LCD show the speed with RPM unit, otherwise, LCD display “0”

• **F-12 Low speed voltage compensation (boost).**



Application of compensation function make frequency inverter get adjustment compensation when low speed runs, thus ensure the motor start steadily.

• **F-13 Terminal or keyboard controlling select (controlling mode)**



Set motor Start/Stop controlling via terminal or keypad.

Set frequency reference controlling via terminal or keypad

When  $F-13=0$ , both “Start/Stop” and frequency reference come from terminal controlling, (Pls. refer to F-20)

When  $F-13=2$ , Control speed via UP  or DOWN ,

Repeat press “Run” Key  to achieve FWD/REV functions

Press “STOP” Key , and then Press “Run” Key 

Drive start to make motor still run as FWD direction.

When F-13=4, Control speed via the potentiometer on the keypad  
Press “Run” Key ① to start motor and achieve FWD/REV function.

When F-13=6, Control speed via the potentiometer on the keypad  
Control START/STOP via terminal controlling,

If F-20=0 means two-wire system controlling,

If F-20=1 means three-wire system controlling,

If F-20=2,3,4, Parameter disable

When F-13=8, Control speed via terminal  
Control Start/Stop via keypad

#### • F-14 Trip log record.

The previous 4 trips records can be stored according time in sequence, the earliest appearance record is recent trip record.

Press ▲ or ▼ key, 4 records are alternative.

#### • F-15 Enter “extended menu access” menu.

Input default “10” to enter into “extended menu access”, this default can be modified through parameter F-45.

Forbid non-authorization entering into “Expansion Menu access”.

### Expansion parameter group

#### • F-16 Drive capacity

Read only.

#### • F-17 Input analog signal format

Input analog voltage/current signal through terminal 6, which be regarded as external frequency given signal.

When analog input is current signal, pls. put the SC socket on left side CPU board (Pls. refer to Page 8--connection diagram)

If bipolar signal set as -10~10V & F-13=0, frequency inverter run FWD/REV is controlled by polarity signal

**•F-18 Carrier wave frequency selection.**

Effective power stage switching frequency inverter. Improvements in acoustic noise and output current waveform occur with increasing switching frequency at the expense of increased losses within the drive  
0: 2 KHz, 1:4 KHz, 2:8 KHz, 3:12 KHz, 4:15KHz

**•F-19 Multi-function contact output selection.**

Relay contact output “ON/OFF” function indicate the working status of drive

**•F-20 Multi-functions contact input selection.**

Multi-functions terminal 1, 2, 3 and 4 correspondence common terminals to effect ON/OFF functions, the definition please refer to F-20 multi-functions contact input menu.

**• F-21~F-28 multi-stages speed 1~8.**

Refer to multi-functions contact input (F-20), Preset multi-speed 1~8 according to actual running requirement

**•F-29 Slip compensation**

Slip modification factor, whose numerical definition is applied as interior calculation for slip compensation percentage.

**•F-30 Analog output functions.**

The terminal 8(-), 9(+) is the multi-function analog output terminal.

As F-30=0, output  $10V = F-01 * 100\%$  correspondence actual output frequency.

As F-30=1, output  $5V = F-08 * 100\%$ , Correspondence motor currents

As F-30=2, Give a digital output

As F-30=3, output  $10V = F-01 * 100\%$  correspondence set frequency

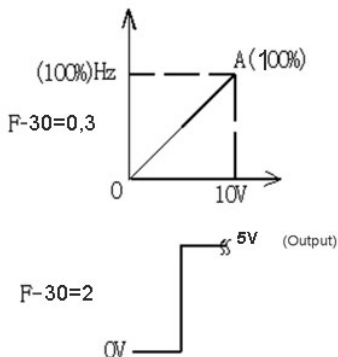
**•F-31 Skip frequency/speed.**

Skip frequency center controlling points are defined by F-31, when the frequency is negative (-), F-32 appear to 0.

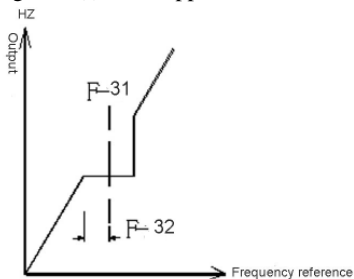

**•F-32 skip frequency/speed band.**

The center is defined by F-31.

**•F-33 V/F Characteristic Curve Mid. Frequency 1**

Pls. refer to V/F curve picture

**•F-34 V/F Characteristic Curve Mid. Frequency 1  
Correspondence output voltage**

Pls. refer to V/F curve picture

**•F-35 V/F Characteristic Curve Mid. Frequency 2**

Pls. refer to V/F curve picture

**•F-36 V/F Characteristic Curve Mid. Frequency 2  
Correspondence output voltage**

Pls. refer to V/F curve picture

**•F-37 Starting mode.**

(A) When F-37 =1, If terminal 1 & 5 is “ON” before electrify, drive can not be started. Pls. put the terminal 1& 5 “OFF” first, and then put terminal 1 & 5 “ON”, the motor start.

(B)When F-37=0, Drive will run when terminal 1& 5 “ON”

**•F-38 DC injection voltage**

If F-05 selection is “ramp to stop”, F-38 sets the level of DC braking applied when the ramp reach zero

**•F-39 DC injection braking time**

If F-05 selection is “ramp to stop”, F-39 sets the duration of DC braking applied when the ramp reaches zero

**•F-40 DC injection braking time before start****•F-41 DC injection function**

As F-41=1, if drive is on working, the DC injection functions enable and will execute according to parameter F-39 & F-40

**•F-42 Braking resistor function select**

Activate interior brake resistor.

When F-42=1, Brake resistor functions enable.

When F-42=2, Should be overload protection to avoid resistor and drive damaged

**•F-43 Frequency instruction adjustment factor.**

Scales the analog signal (Voltage/Current) input at control terminal 6 & output frequency.

Appear the correspondence analog input value according to parameter F-01.

The analog input default is +10V  
correspondence F-01 which is the  
absolute value of input gain  
(Pls. see the picture)

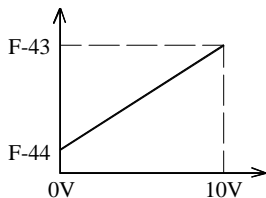
**•F-44 Analog input Bias**

This Parameter is used for compensation of frequency reference bias,  
Pls. refer F-43

**•F-45 Enter “Extended menu access” code**

Define the password for “Extended menu access”(F-15)



**•F-46 Parameter access lock**

Controls user access to parameters.

When F-46=0, all parameters can be changed and these changes will be stored automatically. When

When F-46=1, changes may be made, but these will not be stored when the drive power cut off.

When P-46=2, Parameters are locked and cannot be changed thus preventing unauthorized access

**•F-47 Accumulation running time (Hours run meter)**

Read only.

**•F-48 PID control samples cycle**

**•F-49 PID control proportional factor**

**•F-50 PID control integral constant**

When F-20=3, Drive output frequency is decided by PID close-loop controller. PID parameter can be set via “Up” ▲ and “Down” ▼ key on the keypad (Full range value is equal to value of F-01; For example, If F-01=50, the full range is 50.00)

Unit (PID) is decided according to physical circumstance, If PID set value is for water pressure, 10.00 should be regarded as 10.00Mpa.

The feedback of PID controller input from Terminal 6, Analog input format & type is decided by F-17 & F-43

**•F-51 Analog output gain**

As adjustment of analog output voltage standard, if the maximum output voltage is less than 10V, it is necessary to reduce the parameter value of F-51

**•F-52 Jog Running**

When F-20 = 7, Jog reference is prior to other references, which given by F-52

## 10. Fault diagnosis and corrective actions

### 10.1 Notes for remedy once fault detects.

- If want to eliminate abnormality, must clean up the abnormality conditions and withdraw controlling terminal order, then press ① (“STOP” key) to reset, drive would start automatically,(re-start automatically according to parameter F-37.)
- If motor stop and inverter appear “Stop”, which mean drive is Non-abnormality, it’s under standby.

### 10.2 TROUBLESHOOTING

Fault Code	What has happened	What to do
P-SET	Default parameters loaded	Press STOP key to acknowledge and enter parameter values.
O-C	Over current on drive output. Drive output current exceed OC level	1.Check motor coil resistance 2.Extend the accel/decal time 3.Check motor insulation 4.Multi-meter check
O-Volt	Over voltage on DC bus	1.Extend the deceleration time 2. Fit braking controller and braking resistor 3.Check input voltage
U-Volt	Under voltage on DC bus	1.Main circuit DC voltage is lower than detected voltage. 2.check power voltage & wire.
OC-brt	Brake resistor short circuit.	1.Check cable 2.Check braking resistor
OL-trp	Overload 150% current >1 min.	1.Check motor loading and reduce loading
PS-Flt	Internal power module fault.	Pls. contact your local Distributor

OH-trp	Heatsink over-heat	1.Check heatsink fan 2. Check ambient temperature. 3. Additional space or cooling needed?
UN-Flt	Fault source not found	Try again. If not, Pls. refer to your local distributor.
IN-Flt	External input fault	Pls. check status of terminal 3
EE-Flt	EEPROM fault. Parameters not saved, Keep default	Try again. If not, Pls. refer to your local distributor.

### 10.3 Notice on running

**Acceleration/deceleration:** Too short ramp time may cause over current (>150% or rated current), which may cause accel/ decel not to be achieved, and/ or O-C fault.

**Overload protection:** When drive work with full loading current and over current (150% of overloading current > 1min.)the drive should occur fault, LCD should be twinkling.

## 11-1. B801-200V series standard specification

B801 series	2001	2002	2003	2005	2007	2010
Voltage	1or 3 $\phi$ 200V-240V			3 $\phi$ 200V-240V		
Capacity (KW)	0.75	1.5	2.2	3.7	5.5	7.5
Rated output vol. (V)	3 $\phi$ 220V-240V					
Rated output current A	4.3	7.0	10.5	14	19.6	26.6
Control mode	Sine wave PWM control					
Output frequency range	Maximum 500Hz					
Frequency resolution	Analog input volume: 0.1Hz					
Overloading capacity	Rated output current 150%-1 minute 175% -2 seconds.					
Analog signal input	0~10V, 10~0V, -10~10V, 4~20mA, 0~20mA, 20~4mA 6 types of standard signals.					
No. of V/F Patterns	Random V/F curve.					
Location	Indoor (protected from corrosive gases and dust)					
Ambient temperature	-10~40°C (If beyond the allowable degree, one degree will derogate 5% output current).					
Storage temperature	-40~60°C					
Environmental temperature	95% (without dew gather)					
Vibration	2M/S <sup>2</sup> (0.2G)					
Protection rate	IP20					
<b>*** 0.37kw &amp; 0.55kw also are available.</b>						

## 11-2. B801-400V series standard specification

B801	4001	4002	4003	4005	4007	4010
Voltage	3φ 380V-440V					
Capacity (KW)	0.75	1.5	2.2	3.7	5.5	7.5
Rated output vol. (V)	3φ 380V-440V					
Rated output current A	2.2	4.1	5.8	9.5	13	16
Control mode	Sine wave PWM control					
Output frequency range	Maximum 500Hz					
Frequency resolution	Analog input volume: 0.1Hz					
Overloading capacity	Rated output current 150%-1 minute 175% -2 seconds.					
Analog signal input	0~10V, 10~0V, -10~10V, 4~20mA, 0~20mA, 20~4mA 6 types of standard signals.					
No. of V/F Patterns	Random V/F curve.					
Location	Indoor (protected from corrosive gases and dust)					
Ambient temperature	-10~40°C (If beyond the allowable degree, one degree will derogate 5% output current).					
Storage temperature	-40~60°C					
Environmental temperature	95% (without dew gather)					
Vibration	2M/S <sup>2</sup> (0.2G)					
Protection rate	IP20					



B801 Series Frequency inverter

AGENT: