

AQUATROL

AQT-285

POWERFLO SERIES



AQUATROL[™]
CONTROL VALVES

SERVICE MANUAL

TABLE OF CONTENTS

| | |
|-----------------------------------------------|----|
| General Residential Installation | 3 |
| Valve Start-up Setting Procedures | 4 |
| Regeneration Cycle Program Setting Procedures | 6 |
| Water Conditioner Flow Diagrams | 7 |
| Dimensional Drawings | 10 |
| Meter Assembly and Parts List | 11 |
| Control Valve Assembly | 12 |
| Control Valve Assembly Parts List | 13 |
| Control Drive Assembly | 14 |
| Control Drive Assembly Parts List | 15 |
| 1600 Brine System Assembly and Parts List | 16 |
| 1700 Brine System Assembly and Parts List | 17 |
| Troubleshooting | 18 |
| Wiring Diagram | 20 |
| Installation Drawings | 21 |
| Notes | 22 |



| | |
|-------------------|------------------------------------------------------------------|
| Water Pressure | Minimum 25 PSI |
| Electrical Supply | Uninterrupted AC. Check voltage compatibility |
| Existing | Free of any deposits or build-ups inside pipes |
| Softener | Locate close to drain and connect according to plumbing codes |
| Bypass Valves | Always provide for bypass valve if unit is not equipped with one |

| CAUTION | |
|-----------------------------------------------------------------------------------|--------------------------------------------|
|  | Do not exceed 120 PSI water pressure |
| | Do not exceed 100°F water temperature |
| | Do not subject unit to freezing conditions |

Installation Instructions

- Place the softener tank where you want to install the unit making sure the unit is level and on a firm base. (Maximum 4 feet apart for twin units.)
- All plumbing should be done in accordance with local plumbing codes. The pipe size for the drain line should be the same size as the drain line flow control female connection. Water meters are to be installed on soft water outlets. Twin units with (1) one meter shall be installed on common soft water outlets of units.
- Solder joints near the drain must be done prior to connecting the Drain Line Flow Control fitting. Leave at least 6" between the DLFC and solder joints when soldering when the pipes are connected on the DLFC. Failure to do this could cause interior damage to the DLFC.
- Teflon tape is the only sealant to be used on the drain fitting. The drain from twin units may be run through a common line.
- Make sure that the floor is clean beneath the salt storage tank and that it is level
- Place approximately 1" of water above the grid plate (if used) in your salt tank. Salt may be place in the unit at this time.
- On units with by-pass, place in by-pass position. Turn on main water supply. Open a cold soft water tap nearby and let run a few minutes or until the system is free from foreign material (usually solder) that may have resulted from the installation.
- Place the by-pass in service position.
- Manually index the softener control into "service" position and let water flow into the mineral tank. When water flow stops, open a cold water tap nearby and let run until air pressure is relieved.
- Electrical: All electrical connections must be connected according to codes. Use electrical conduit if applicable. See Wiring Diagram section for more information.
- Plug into power supply

AQT-285

Timer Setting Procedures



How To Set Days On Which Water Conditioner Is To Regenerate:

Rotate the skipper wheel until the number "1" is at the red pointer. Set the days that regeneration is to occur by sliding tabs on the skipper wheel outward to expose trip fingers. Each tab is one day. Finger at red pointer is tonight. Moving clockwise from the red pointer, extend or retract fingers to obtain the desired regeneration schedule.

How To Set The Time Of Day:

Press and hold the white button to disengage the drive gear. Turn the large gear until the actual time of day is at the time of day pointer. Release the white button to again engage the drive gear.

How To Manually Regenerate Your Water Conditioner At Any Time:

Turn the manual regeneration knob clockwise. This slight movement of the manual regeneration knob engages the program wheel and starts the regeneration program. The black center knob will make one revolution in the following approximately three hours and stop in the position shown in the drawing. Even though it takes three hours for this center knob to complete one revolution, the regeneration cycle of your unit might be set only one half of this time. In any event, conditioned water may be drawn after rinse water stops flowing from the water conditioner drain line.

How To Adjust Regeneration Time:

1. Disconnect the power source.
2. Locate the three screws behind the manual regeneration knob by pushing the white button in and rotating the 24 hour dial until each screw appears in the cut out portion of the manual regeneration knob.
3. Loosen each screw slightly to release the pressure on the time plate from the 24 hour gear.
4. Locate the regeneration time pointer on the inside of the 24 hour dial in the cut out.
5. Turn the plate so the desired regeneration time aligns next to the raised arrow.
6. Push the white button in and rotate the 24 hour dial. Tighten each of the three screws.
7. Push the white button and locate the pointer one more time to ensure the desired regeneration time is correct.
8. Reset the time of day and restore power to the unit.

**IMPORTANT:
SALT LEVEL MUST ALWAYS BE ABOVE WATER
LEVEL IN BRINE TANK.**

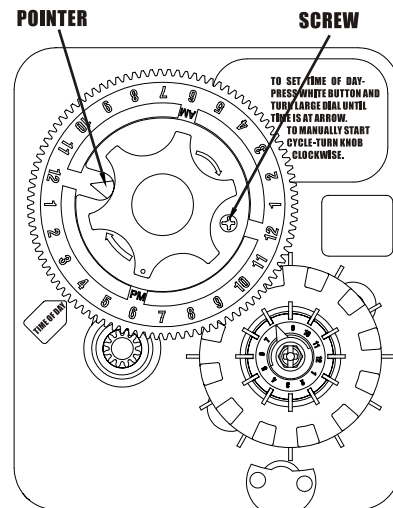
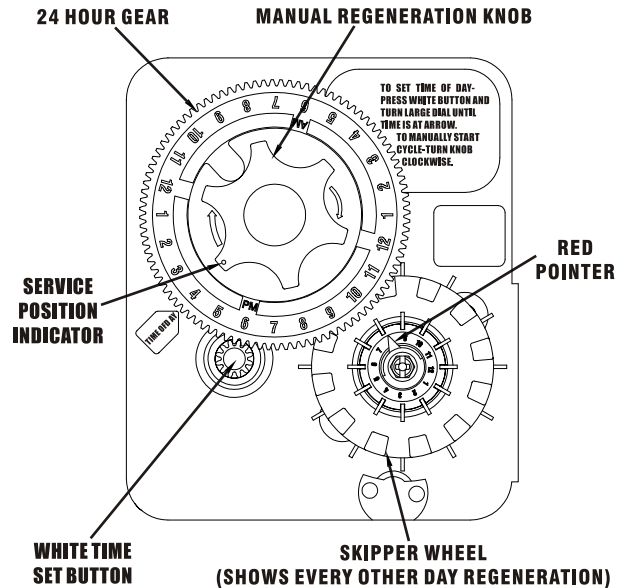

13200 ADJUSTABLE REGENERATION TIMER

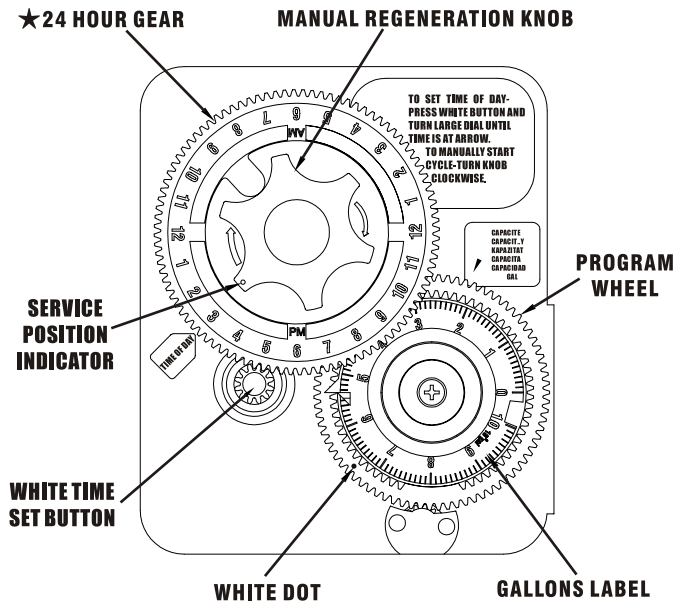

NOTE:
To set meter capacity rotate manual knob 1-360° revolution to set the gallons.

★ Immediate regeneration timers do not have 24 hour gear. No time of day can be set.

Typical Programming Procedure

Calculate the gallon capacity of the system, subtract the necessary reserve requirement and set the gallons required by lifting the gallon dial and rotating it so that the number of gallons required is aligned with the white dot on the program wheel gear. Release and check for firm engagement with gear.

Note: To set meter capacity at initial start-up, either:

1. Rotate the manual regeneration knob one full revolution.
 - or
 2. Rotate the program wheel manual clockwise and align white dot with capacity arrow.
- This procedure must be followed any time the program wheel setting is changed.

How To Set The Time Of Day:

Press and hold the white button in to disengage the drive gear.
Turn the large gear until the actual time of day is opposite of the time of day pointer.
Release the white button to again engage the drive gear.

How To Manually Regenerate Your Water Conditioner At Any Time:

Turn the manual regeneration knob clockwise one "click".
This slight movement of the manual regeneration knob engages the program wheel and starts the regeneration program.
The black center knob will make one revolution in the following approximately three hours and stop in the position shown in the drawing.
Even though it takes three hours for this center knob to complete one revolution, the regeneration cycle of your unit might be set for only on half of this time.
In any event, conditioned water may be drawn after rinse water stops flowing from the water conditioner drain line.

Immediate Regeneration Times:

These timers do not have a 24 hour gear. Setting the gallons on the program wheel and manual regeneration procedure are the same as previous instructions.

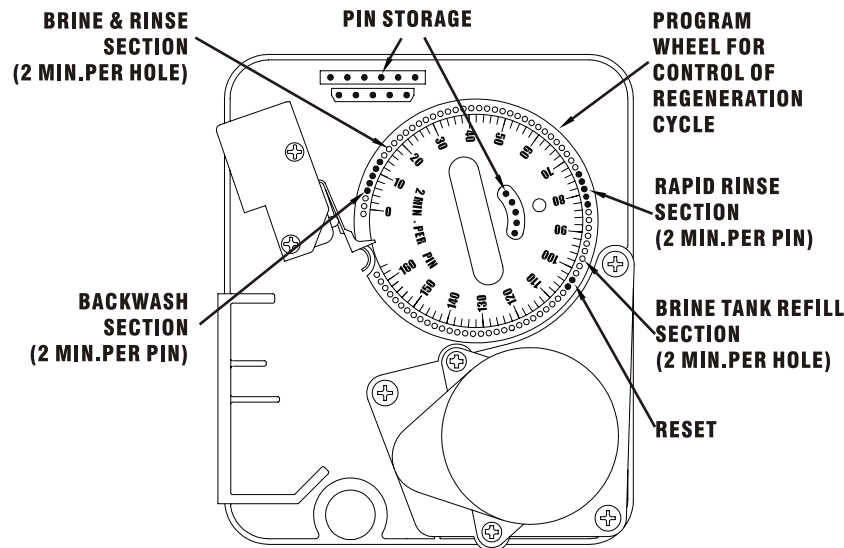

How To Set The Regeneration Cycle Program:

The regeneration cycle program on your water conditioner has been factory preset, however, portions of the cycle or program may be lengthened or shortened in time to suit local conditions.

A-13200 & A-13100 Series Timers

To expose cycle program wheel, grasp timer in upper left hand corner and pull, releasing snap retainer and swinging timer to the right. To change the regeneration cycle program, the program wheel must be removed. Grasp program wheel and squeeze protruding lugs toward center, lift program wheel off timer. (Switch arms may require movement to facilitate removal). Return timer to closed position engaging snap retainer in back plate. Make certain all electrical wires snap above retainer post.

Timer Setting Procedure For A-13200 & A-13210 Timers -

How To Change The Length Of The Backwash Time:

The program wheel as shown in the drawing is in the service position. As you look at the numbered side of the program wheel, the group of pins starting at zero determines the length of time your unit will backwash.

For example: If there are six pins in this section, the time of backwash will be 12 min. (2 min. per pin). To change the length of backwash time, add or remove pins as required. The number of pins times two equals the backwash time in minutes.

How To Change The Length Of Brine And Rinse Time:

The group of holes between the last pin in the backwash section and the second group of pins determines the length of time that your unit will brine and rinse (2 min. per hole).

To change the length of brine and rinse time, move the rapid rinse group of pins to give more or fewer holes in the brine and rinse section. Number of holes times two equals brine and rinse time in minutes.

How To Change The Length Of Rapid Rinse:

The second group of pins on the program wheel determines the length of time that your water conditioner will rapid rinse (2 min. per pin). To change the length of refill time, add or remove pins at the higher numbered end of this section as required. The number of pins times two equals the rapid rinse time in minutes.

How To Change The Length Of Brine Tank Refill Time:

The second group of holes in the program wheel determines the length of time that your water conditioner will refill the brine tank (2 min. per hole).

To change the length of refill time, move the two pins at the end of the second group of holes as required.

The regeneration cycle is complete when the outer microswitch is tripped by the two pin set at the end of the brine tank refill section.

The program wheel, however, will continue to rotate until the inner micro-switch drops into the notch on the program wheel.

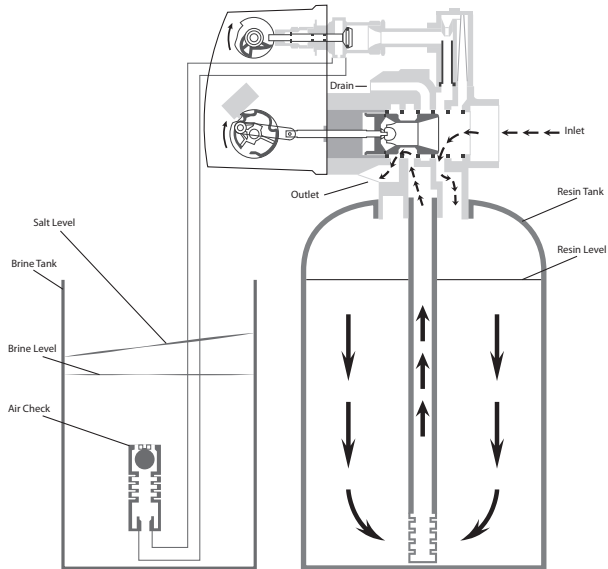

1) Service Position

Hard water enters unit at valve inlet and flows down through the mineral in the mineral tank. Conditioned water enters center tube through the bottom distributor, then flows up through the center tube, around the piston, and out the outlet of the valve.

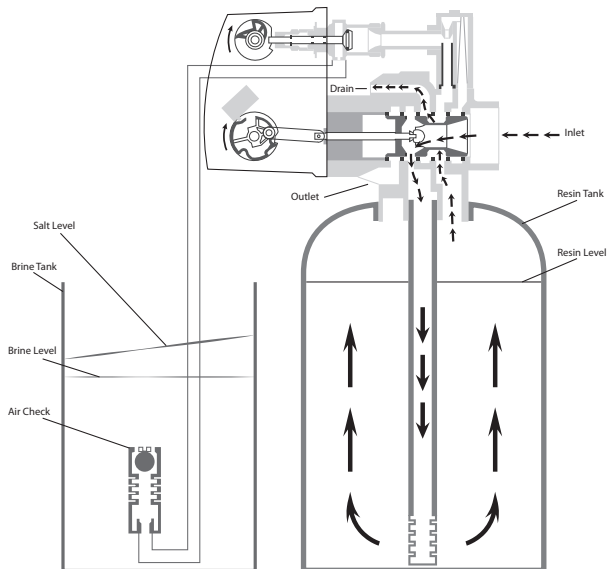

2) Backwash Position

Hard water enters unit at valve inlet - flows through piston - Down through bottom distributor center tube - and up through the mineral - around the piston and out the Drain line

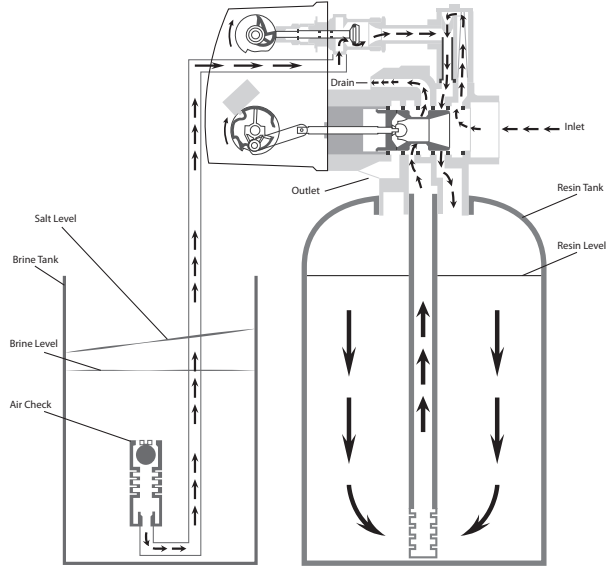

3) Brine and Slow Rinse Position

Hard water enters unit at valve inlet - flows up into injector housing and down through nozzle and throat to draw brine from the brine tank - brine flows down through mineral and enters the center tube through bottom distributor and out through the drain line.

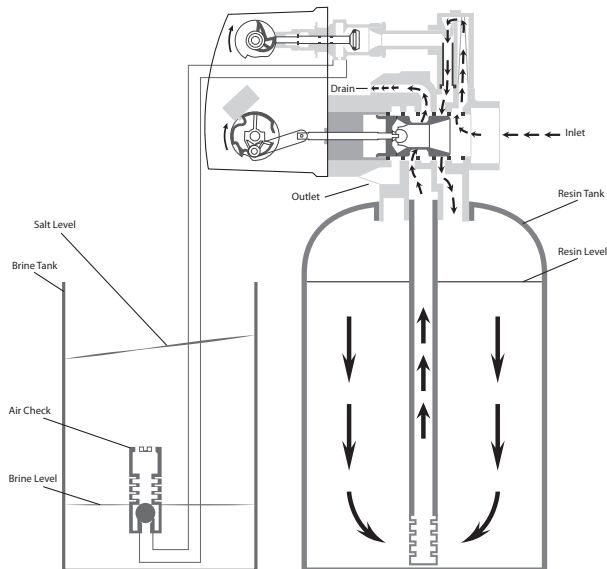

4) Slow Rinse Position

Hard water enters unit at valve inlet - flows up into injector housing and down through nozzle and around throat - down through mineral - enters center tube through bottom distributor - flows up through center tube - around piston and out through drain line.

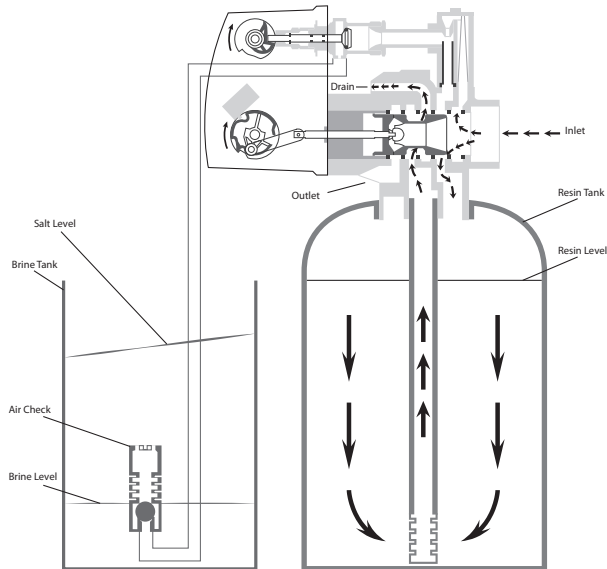

5) Rapid Rinse Position

Hard water enters unit at valve inlet - flows directly from inlet down through mineral into center tube bottom distributor and up through center tube - around piston and out through the drain line.

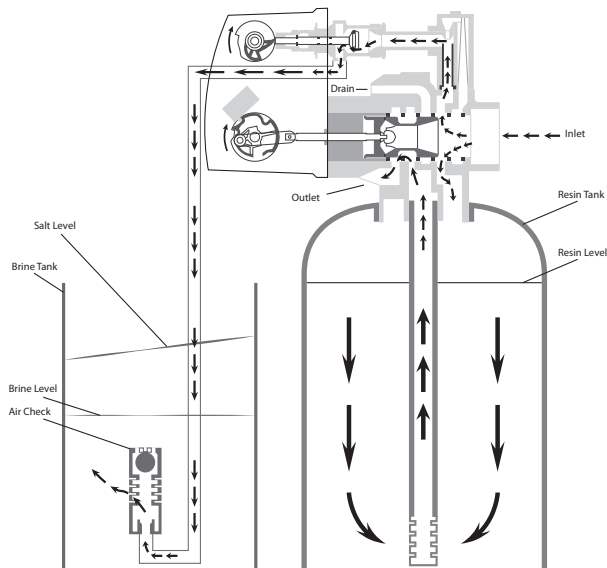

6) Brine Tank Refill Position

Hard water enters unit at valve inlet - flows up through the injector housing - through the brine valve to refill the brine tank.

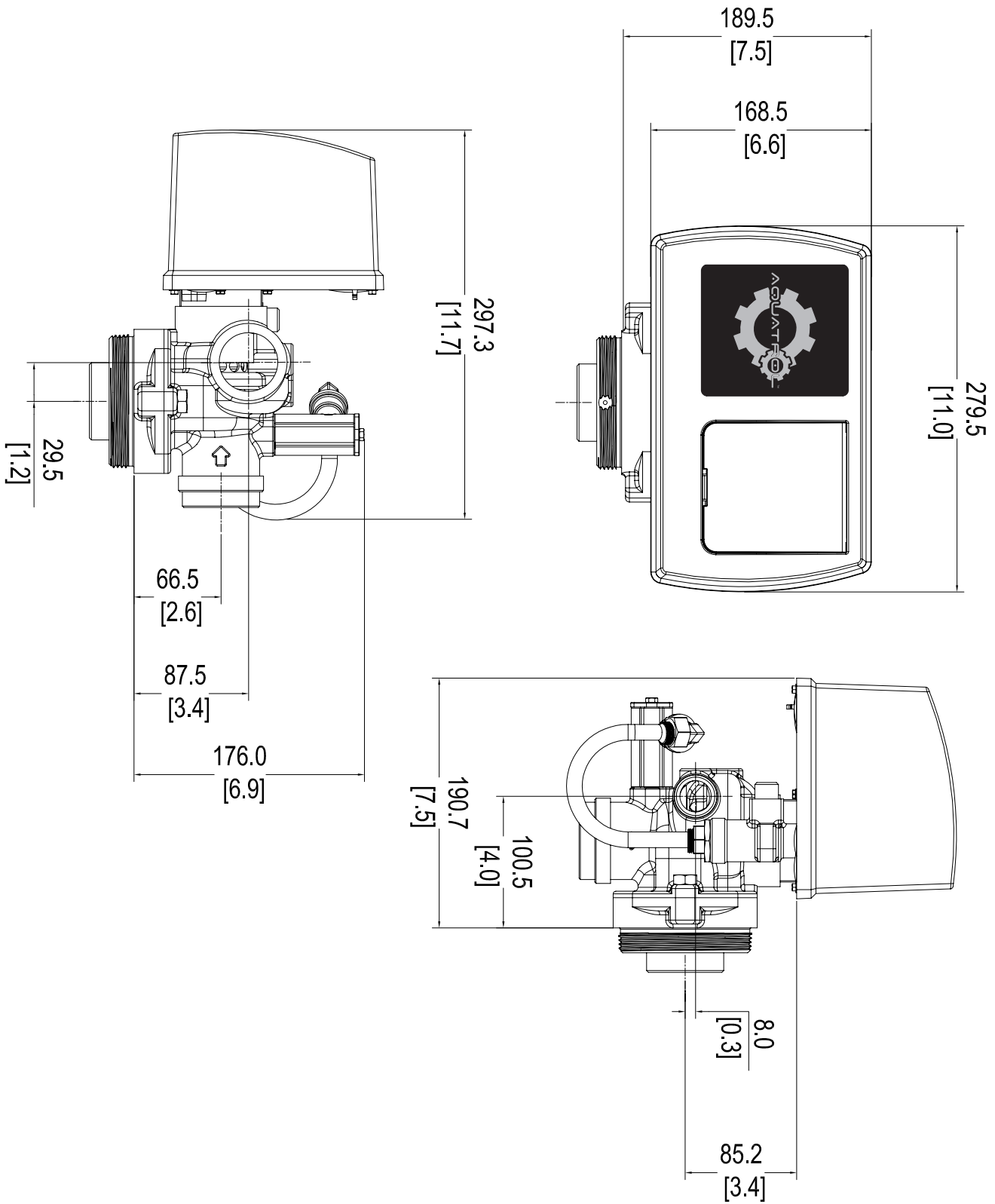

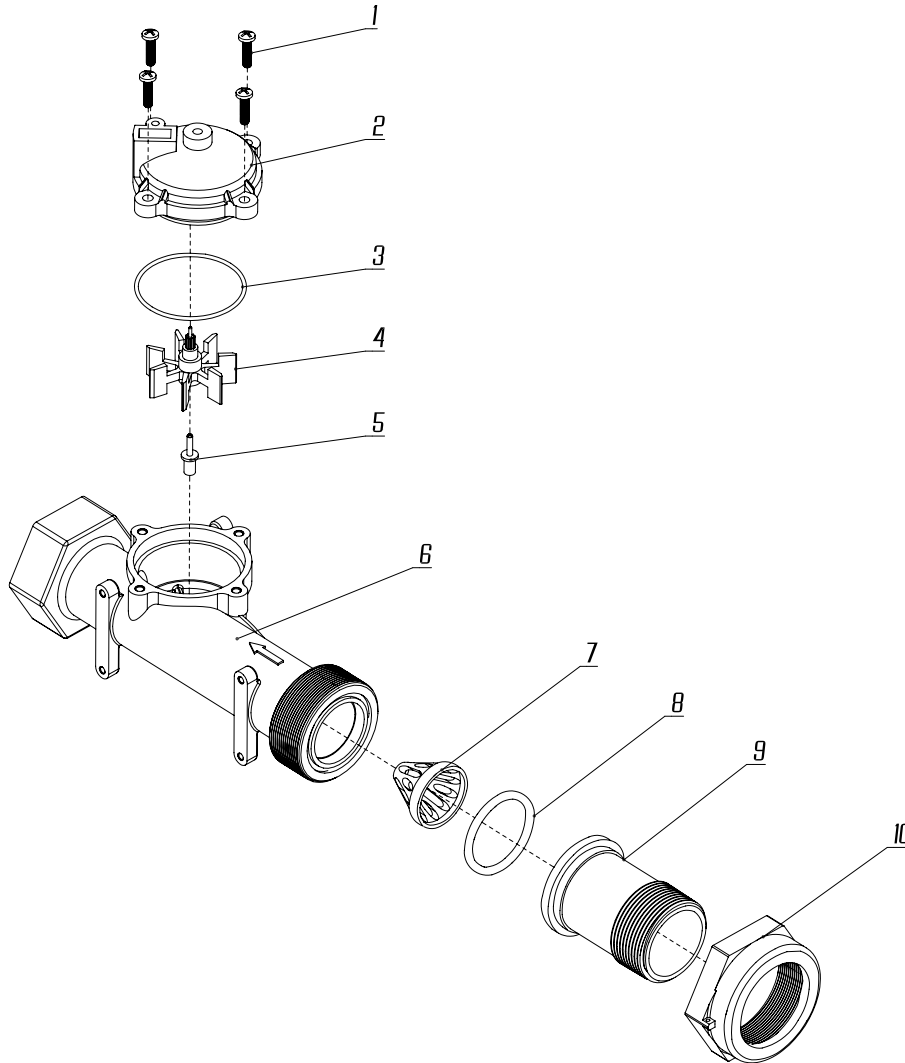

| Item No. | Quantity | Part No. | Description |
|----------|----------|----------|----------------------|
| 1 | 4 | A02082F | Screw |
| 2 | 1 | A15218 | Meter Cover Assembly |
| 3 | 1 | A13847 | O-ring |
| 4 | 1 | A12204AF | Impeller Assembly |
| 5 | 1 | A12101F | Impeller Spindle |
| 6 | 1 | A12120F | Body |
| 7 | 1 | A17542 | Flow Straightener |
| 8 | 1 | A12733 | O-ring |
| 9 | 1 | A12121F | Tube |
| 10 | 1 | A17543 | Screw |

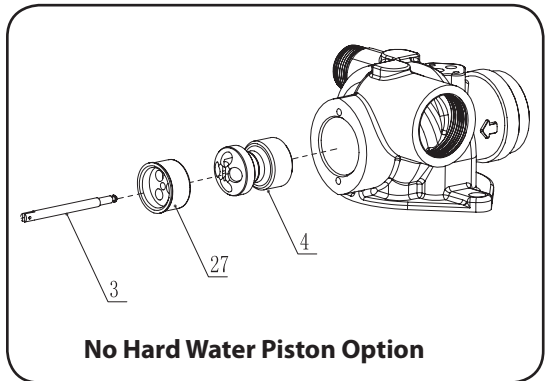
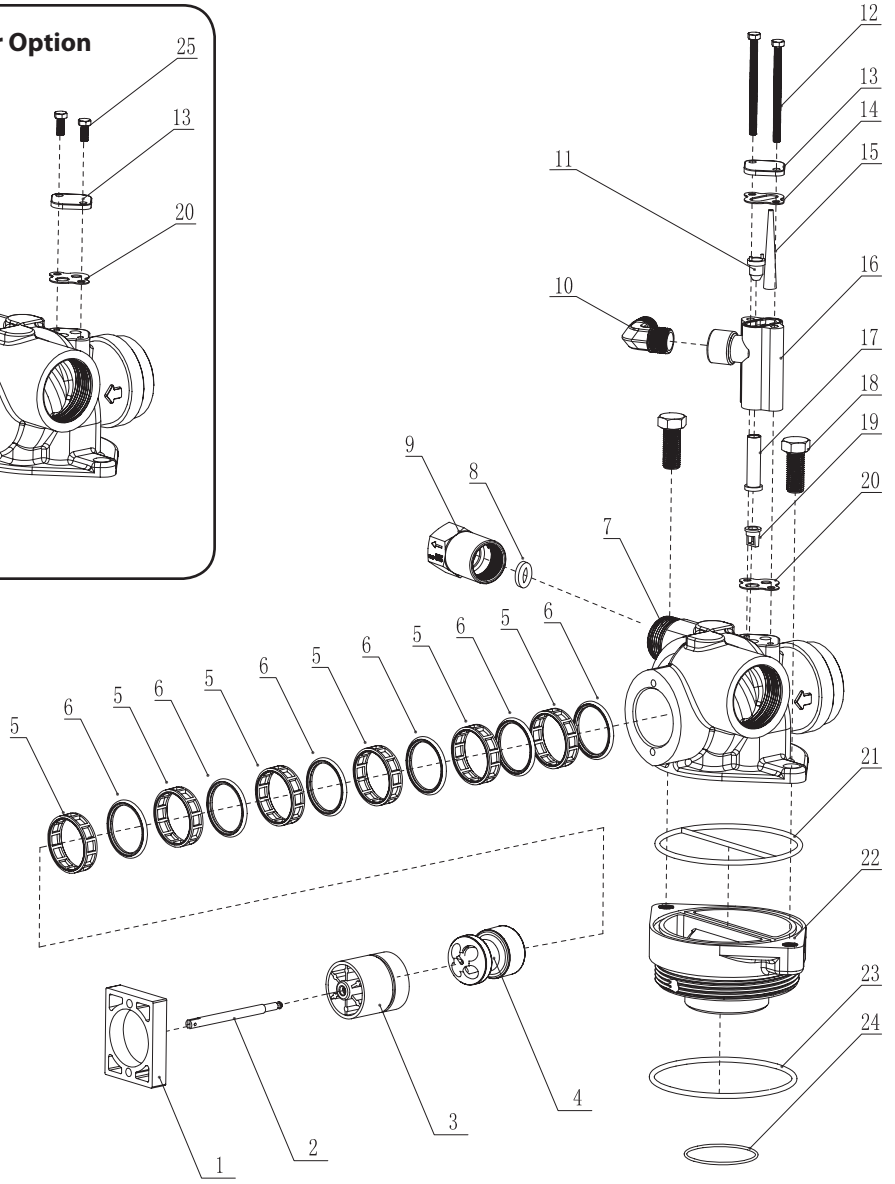
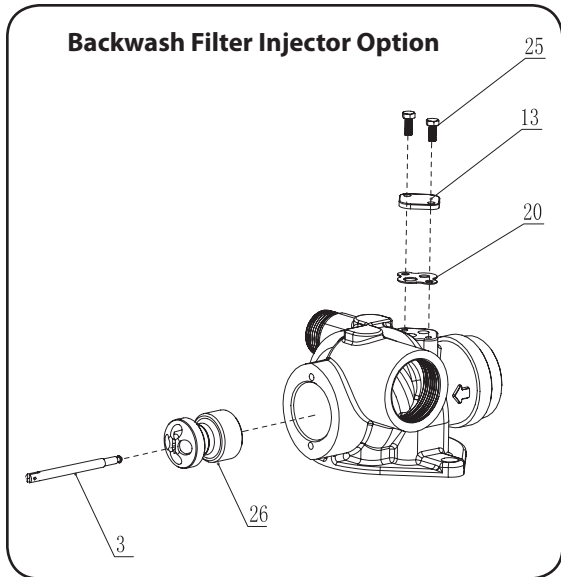

| Item No. | Quantity | Part No. | Description |
|----------|----------|-----------|--------------------------------------|
| 1 | 1 | A19339 | Spacer |
| 2 | 1 | A16436 | Piston Rod |
| 3 | 1 | A66121F | End Plug Assembly |
| 4 | 1 | A16092 | Piston |
| 5 | 6 | A16638-01 | Seal |
| 6 | 6 | A16101 | Spacer |
| 7 | 1 | A16250 | Valve Body |
| | 1 | | Adapter Base |
| | 1 | | Seal |
| | 2 | | Bolt |
| 8 | 1 | | D.L.F.C. |
| 9 | 1 | A60366-XX | Drain Connector |
| 10 | 1 | A15413 | Brine Valve Connector |
| 11 | 1 | A14801 | Nozzle |
| 12 | 2 | A02051F | Screw |
| 13 | 1 | A11893 | Injector Cover |
| 14 | 1 | A10229 | Injector Cover Gasket |
| 15 | 1 | A14803 | Injector Screen |
| 16 | 1 | A17777 | Injector |
| 17 | 1 | A14802 | Injector Throat |
| 18 | 2 | A02053F | Bolt |
| 19 | 1 | A17996 | Air Disperser |
| 20 | 1 | A14805 | Injector Body Gasket |
| 21 | 1 | A28531F | Seal |
| 22 | 1 | A28551F | Adapter Base |
| 23 | 1 | A16455 | O-Ring |
| 24 | 1 | A13577 | O-Ring |
| 25 | 2 | A10692 | Bolt |
| 26 | 1 | A28557-1F | Filter Piston |
| 27 | 1 | A19298-01 | No Hard Water Bypass Piston Assembly |

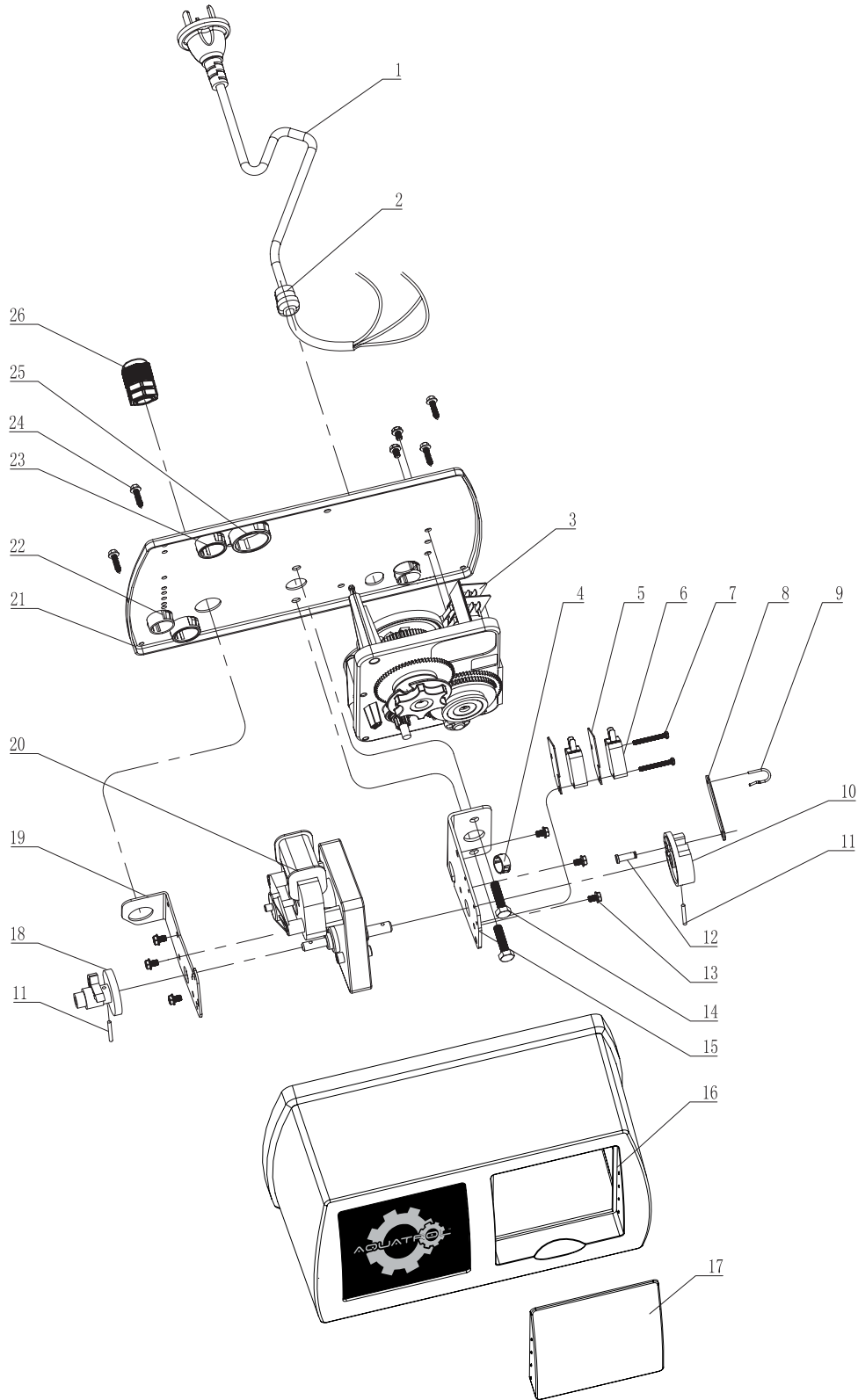

| Item No. | Quantity | Part No. | Description |
|----------|----------|----------|----------------------|
| 1 | 1 | A11838 | Power Cord |
| 2 | 1 | A13547 | Strain Relief |
| 3 | 1 | A13200F | Timer 13200 (12 day) |
| 4 | 1 | A07012F | Strain Relief |
| 5 | 2 | A10302 | Insulator |
| 6 | 2 | A10218 | Switch |
| 7 | 2 | A14923 | Screw |
| 8 | 1 | A10621 | Connecting Link |
| 9 | 1 | A10909 | Connecting Link Pin |
| 10 | 1 | A12576 | Drive Cam |
| 11 | 2 | A10338 | Pin |
| 12 | 1 | A13366 | Pin |
| 13 | 8 | A10872 | Screw |
| 14 | 2 | A02056F | Screw |
| 15 | 1 | A10774 | Bracket |
| 16 | 1 | A19041F | Cover |
| 17 | 1 | A19042F | Plate Cover |
| 18 | 1 | A12777 | Brine Valve Cam |
| 19 | 1 | A11826 | Brine Valve Bracket |
| 20 | 1 | A10769 | Motor |
| 21 | 1 | A19001F | Back Plate |
| 22 | 2 | A19043F | Plate Plug (Small) |
| 23 | 2 | A19044 | Plate Plug (Middle) |
| 24 | 4 | A02103 | Screw |
| 25 | 1 | A19045 | Plate Plug (Big) |
| 26 | 1 | A19048 | Screw Cap |

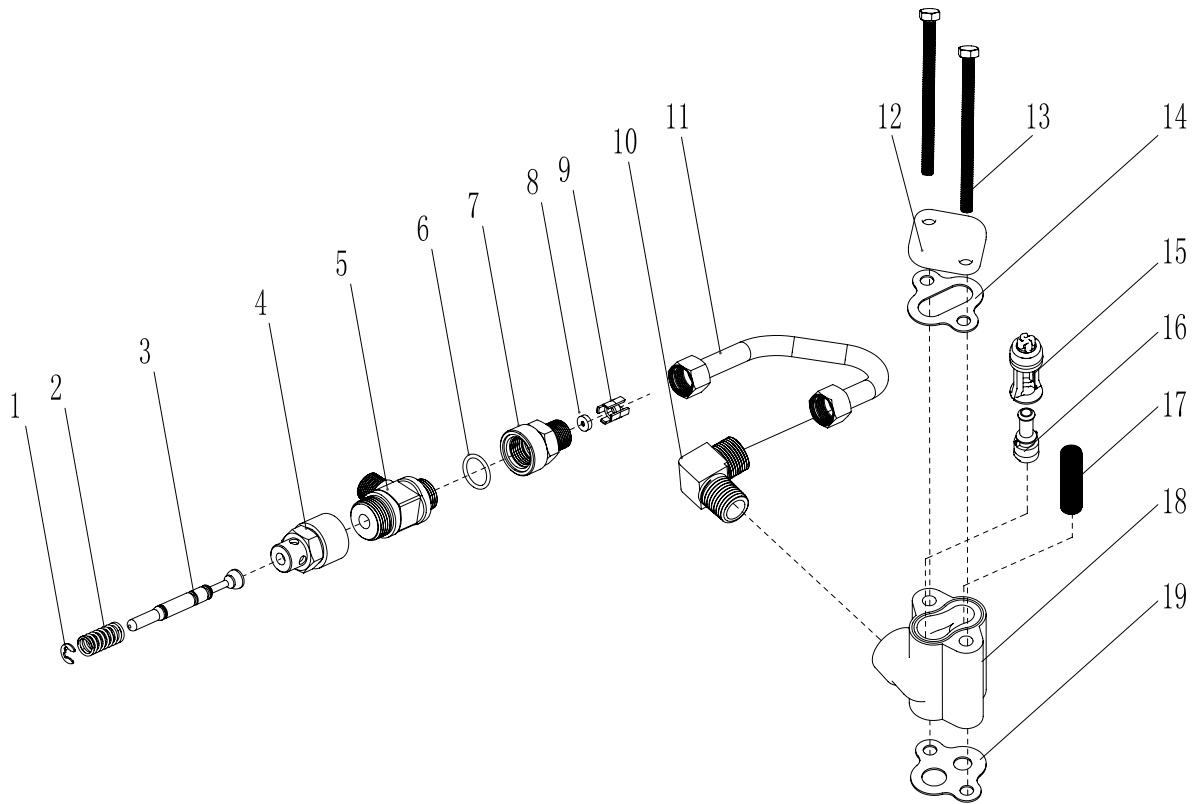

| Item No. | Quantity | Part No. | Description |
|----------|----------|----------|-----------------------|
| 1 | 1 | A10250 | Retaining Ring |
| 2 | 1 | A10249 | Spring |
| 3 | 1 | A66122F | Brine Stem Assembly |
| 4 | 1 | A11749 | Stem Guide |
| 5 | 1 | A16051F | Brine Valve Body |
| 6 | 1 | A11982 | O-Ring |
| 7 | 1 | A16054F | End Plug, Brine Valve |
| 8 | 1 | | BLFC Button |
| 9 | 1 | A56015F | Brine Dispenser |
| 10 | 1 | A10328 | Fitting, Elbow |
| 11 | 1 | A66124F | Brine Tube |
| 12 | 1 | A11893 | Injector Cover |
| 13 | 2 | A02060F | Screw |
| 14 | 1 | A10229 | Injector Cover Gasket |
| 15 | 1 | | Injector Nozzle |
| 16 | 1 | | Injector Throat |
| 17 | 1 | A56059F | Screen |
| 18 | 1 | A16001F | Injector Body |
| 19 | 1 | A14805 | Injector Cover Gasket |

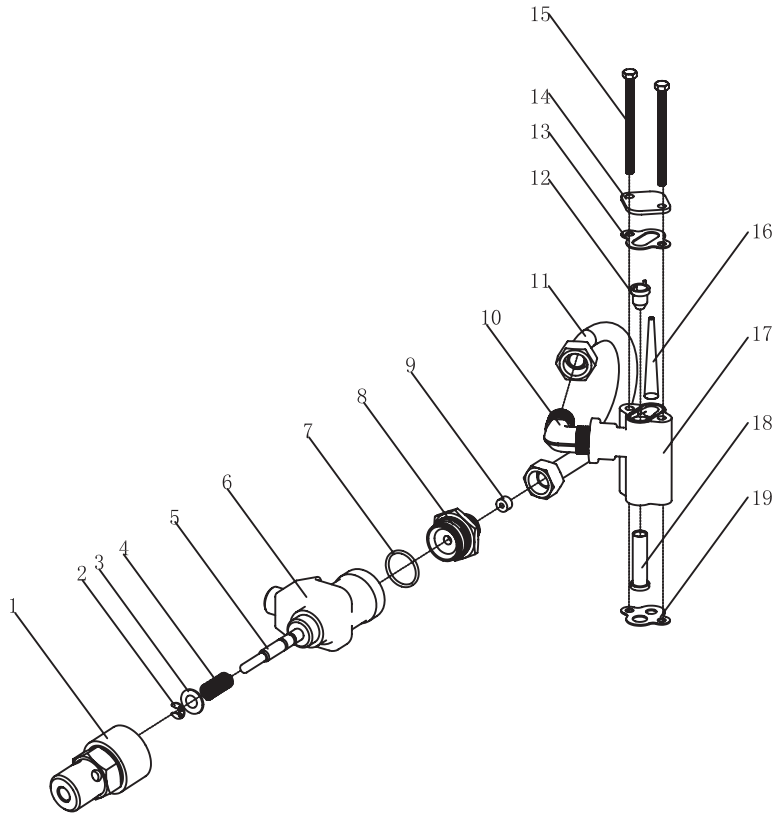

| Item No. | Quantity | Part No. | Description |
|----------|----------|------------|--------------------------|
| 1 | 1 | A 66164F | Brine valve cap assembly |
| 2 | 1 | A10250 | Retaining Ring |
| 3 | 1 | A04003F | Washer |
| 4 | 1 | A15310 | Spring |
| 5 | 1 | A66128F | Brine Stem Assembly |
| 6 | 1 | A17053F | Brine Valve Body |
| 7 | 1 | A13201 | O-Ring |
| 8 | 1 | A17055F | End Plug, Brine Valve |
| 9 | 1 | | BLFC Button |
| 10 | 1 | A15413 | Fitting, Elbow |
| 11 | 1 | A66160F | Brine Tube |
| 12 | 1 | A14801-XXC | Injector Nozzle |
| 13 | 1 | A10229 | Injector Cover Gasket |
| 14 | 1 | A11893 | Injector Cover |
| 15 | 2 | A02051F | Screw |
| 16 | 1 | A14803 | Screen |
| 17 | 1 | A17777 | Injector Body |
| 18 | 1 | A14802-XXC | Injector Throat |
| 19 | 1 | A14805 | Injector Cover Gasket |

Troubleshooting

Problems, Cause & Corrections



| Problem | Cause | Correction |
|----------------------------------------|---------------------------------------------------------------------------------------------------------------------|----------------------------------------------------------------------------------------------------------------|
| 1) Softener fails to regenerate. | A) Electrical service to unit has been interrupted. | A) Assure permanent electrical service (check fuse, plug, pull chain or switch). |
| | B) Timer is defective. | B) Replace timer. |
| | C) Power failure. | C) Reset time of day. |
| 2) Hard water. | A) By-pass valve is open. | A) Close by-pass valve. |
| | B) No salt in brine tank. | B) Add salt to brine tank and maintain salt level above water level. |
| | C) Injector screen plugged. | C) Clean injector screen. |
| | D) Insufficient water flowing into brine tank. | D) Check brine tank fill time and clean brine line flow control if plugged. |
| | E) Hot water tank hardness. | E) Repeated flushing of the hot water tanks required. |
| | F) Leak at distributor tube. | F) Make sure distributor tube is not cracked. Check O-ring and tube pilot. |
| | G) Internal Valve Leak. | G) Replace seals and spacers and/or piston. |
| | H) Service Adapter did not return to service. | H) Check drive motor and switch. |
| 3) Unit used too much salt. | A) Improper salt setting. | A) Check salt usage and salt setting. |
| | B) Excessive water in brine tank. | B) See problem No. 7. |
| 4) Loss of water pressure. | A) Iron buildup in line to water conditioner. | A) Clean line to water. |
| | B) Iron buildup in water conditioner. | B) Clean control and add mineral cleaner to mineral bed. Increase frequency of regeneration. |
| | C) Inlet of control plugged due to foreign material broken loose from pipes by recent work done on plumbing system. | C) Remove piston and clean control. |
| 5) Loss of mineral through drain line. | A) Air in water system. | B) Assure that well system has proper air eliminator control. Check for dry well conditions. |
| | B) improper size drain line flow control. | B) Check for proper drain rate. |
| 6) Iron in conditioned water. | A) Fouled mineral bed. | A) Check backwash, brine draw and brine tank fill. Increase frequency of regeneration. Increase backwash time. |
| 7) Excessive water in brine tank. | A) Plugged drain line flow control. | A) Clean flow control. |
| | B) Plugged injector system. | B) Clean injector and screen. |
| | C) Timer not cycling. | C) Replace timer. |
| | D) Foreign material in brine valve. | D) Replace brine valve seat and clean valve. |
| | E) Foreign material in brine line flow control. | E) Clean brine line flow control. |

| Problem | Cause | Correction |
|----------------------------------|-------------------------------------------|------------------------------------------------------------------------------------------------------------------------------|
| 8) Softener fails to draw brine. | A) Drain line flow control is plugged. | A) Clean drain line flow control. |
| | B) Injector is plugged. | B) Clean injector. |
| | C) Injector screen plugged. | C) Clean screen. |
| | D) Line pressure is too low. | D) Increase line pressure to 20 P.S.I. |
| | E) Internal control leak. | E) Change seals, spacers and piston assembly |
| | F) Service adapter did not cycle. | F) Check drive motor and switches. |
| 9) Control cycle continuously. | A) Misadjusted, broken or shorted switch. | A) Determine if switch or timer is faulty and replace it or replace complete power head. |
| 10) Drain flows continuously. | A) Valve is not programming correctly. | A) Check timer program and positioning of control. Replace power head assembly if not positioned properly. |
| | B) Foreign material in control. | B) Remove power head assembly and inspect bore. Remove foreign material and check control in various regeneration positions. |
| | C) Internal control leak | C) Replace seals and piston assembly. |

General Service Hints for Meter Control

Problem: Softener delivers hard water

Reason: Reserve capacity has been exceeded.

Correction: Check salt dosage requirements and reset program wheel to provide additional reserve.

Reason: Program wheel is not rotating with meter output.

Correction: Pull cable out of meter cover and rotate manually. Program wheel must move without binding and clutch must give positive clicks when program wheel strikes regeneration stop. If it does not, replace timer.

Reason: Meter is not measuring flow.

Correction: Check meter with meter checker.

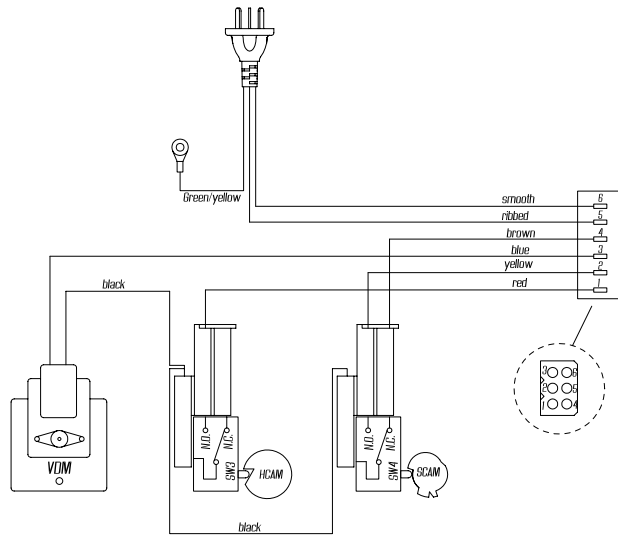

TIMECLOCK OR METER DELAYED REGENERATION TIMER

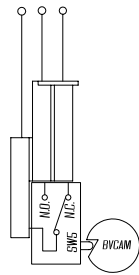
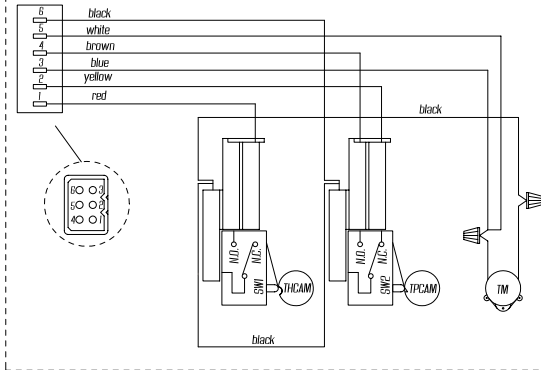

METER IMMEDIATE REGENERATION TIMER

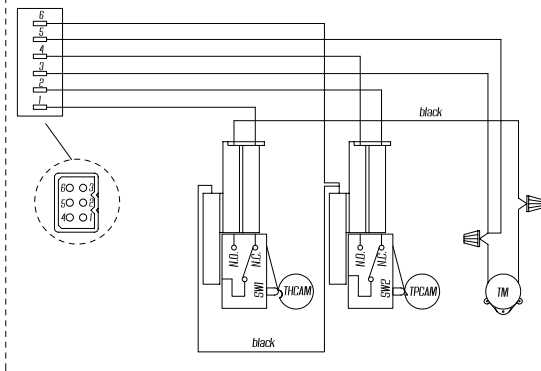

System #4 Immediate/Delayed Regeneration Valve Wiring

- TM** Time Motor
- VDM** Valve Drive Motor
- SW1** Timer Homing Switch
- SW2** Timer Program Switch
- SW3** Valve Homing Switch
- SW4** Valve Step Switch
- SW5** Brine Cam Switch
- THCAM** Timer Homing Cam
- TPCAM** Timer Program CAM
- HCAM** Valve Homing Cam
- SCAM** Valve Step Cam
- BVCAM** Brine Valve Cam

Note:

1. Single tank time clock, meter delayed, or meter immediate regeneration.
2. Valve shown in service position.

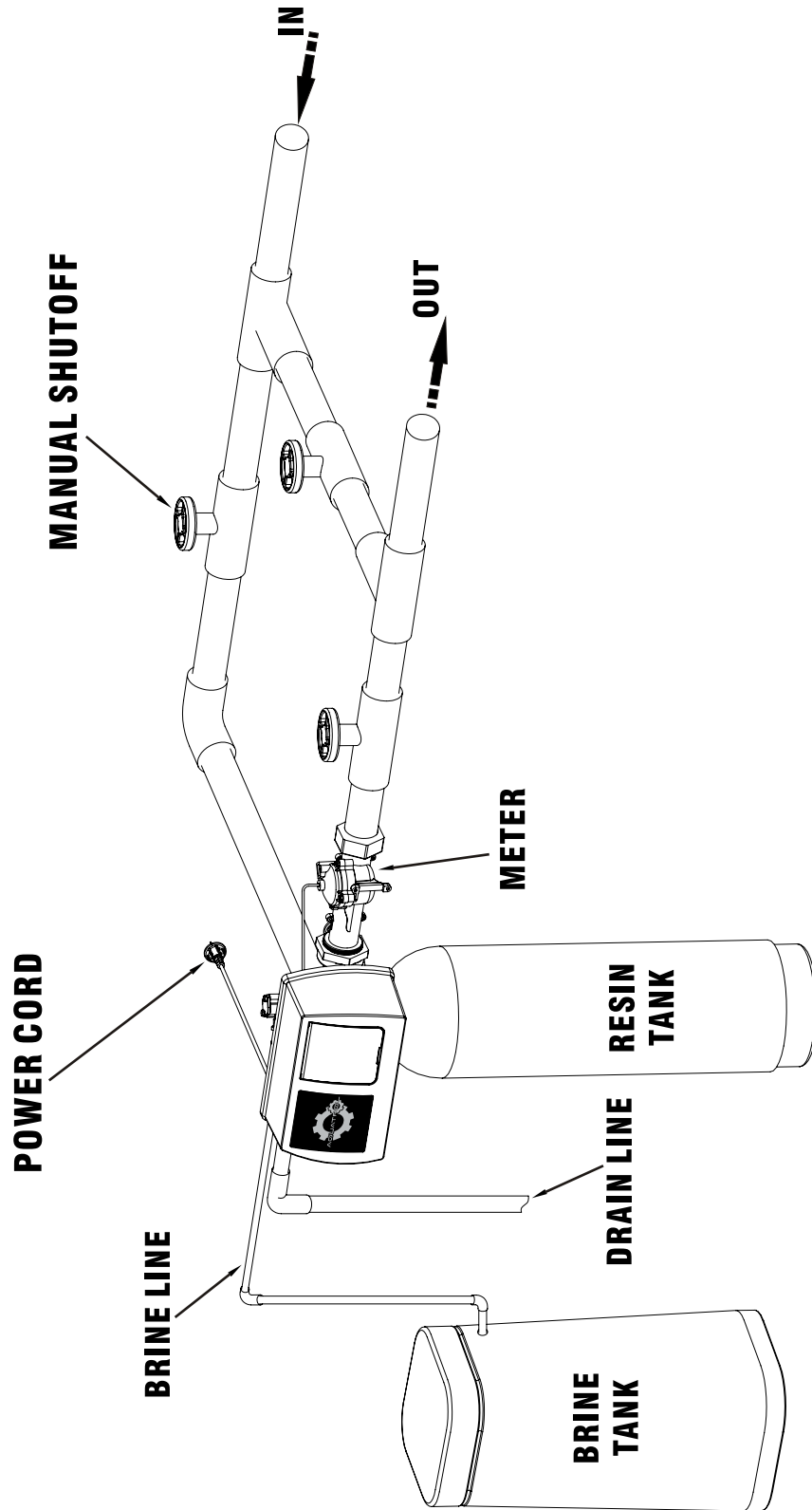

System #4 - Typical Single Tank Installation With Optional Meter

