

OWNERS MANUAL

How to maintain and operate
your Miracle Water
MW-25
Water Softener

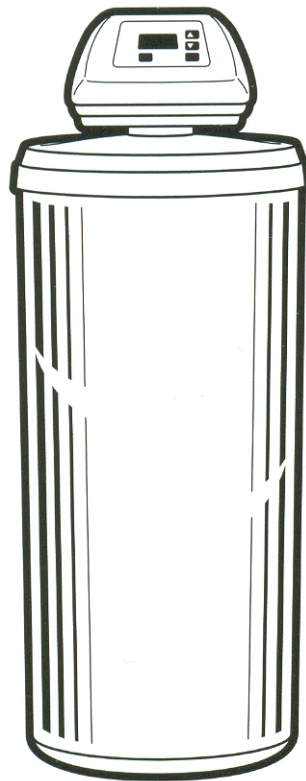



AUTOMATIC WATER SOFTENER

WARRANTY

TEN YEAR LIMITED WARRANTY GENERAL CONDITIONS

Damage to any part of this water softener because of misuse, misapplication, neglect, alteration, accident, installation or operation contrary to our printed instructions, or damage caused by any unusual force of nature such as, but not limited to, freezing, flood, hurricane, tornado, or earthquake is not covered by this warranty. In all such cases, regular parts and service charges will apply.

We assume no warranty liability in connection with this water softener other than specified herein. This warranty is in lieu of all other warranties, expressed or implied, including warranties of fitness for a particular purpose. We do not authorize any person or representative to assume for us any other obligations on the sale of this water softener.

Should a defect or malfunction occur, contact your dealer. If you are unable to contact your dealer, return the part, freight prepaid, directly to the factory at the address below. Enclose with the part a full description of the problem, with your name, full address, date purchased, model and serial numbers, and selling contractor's name and address. We will repair or replace the part and return it to you at no cost if our repair department determines it to be defective under the terms of the warranty.

This warranty gives you specific legal rights and you may have other rights which vary from province to province.

This water softener is manufactured by Miracle Water, 5240 Bradco Blvd, Mississauga, ON L4W 1G7; customer information telephone no. 1-800-356-7851.

WARRANTY POLICY

Miracle Water, Mississauga, ON warrants this water softener as stated herein:

From the date of installation, within the warranty period described below, we will repair or replace any part which we find defective because of faulty materials and workmanship, or corrosion. You pay only freight to our factory and local labor charges.

* ONE YEAR ON COMPLETE UNIT

*THREE YEARS ON ELECTRONIC CONTROL * THREE YEARS ON CONTROL VALVE BODY

* FIVE YEARS ON SALT STORAGE TANK * TEN YEARS ON MINERAL TANK, EXCLUDING MINERAL

SAFETY GUIDES

FOLLOW THE INSTALLATION INSTRUCTIONS CAREFULLY. FAILURE TO INSTALL THE SOFTENER PROPERLY VOIDS THE WARRANTY.

BEFORE YOU BEGIN INSTALLATION, READ THIS ENTIRE MANUAL. THEN, OBTAIN ALL THE MATERIALS AND TOOLS YOU WILL NEED TO MAKE THE INSTALLATION.

CHECK LOCAL PLUMBING AND ELECTRICAL CODES. THE INSTALLATION MUST CONFORM TO THEM. Consult with your licensed plumber.

USE ONLY LEAD-FREE SOLDER AND FLUX FOR ALL SWEAT-SOLDER CONNECTIONS.

USE CARE WHEN HANDLING THE SOFTENER. DO NOT TURN UPSIDE DOWN, DROP, OR SET ON SHARP PROTRUSIONS.

DO NOT LOCATE THE SOFTENER WHERE FREEZING TEMPERATURES OCCUR. DO NOT ATTEMPT TO TREAT WATER OVER 120°F. **FREEZING, OR HOT WATER DAMAGE VOIDS THE WARRANTY.**

AVOID INSTALLING IN DIRECT SUNLIGHT. EXCESSIVE SUN HEAT MAY CAUSE DISTORTION OR OTHER DAMAGE TO NON-METALLIC PARTS.

THE SOFTENER REQUIRES A MINIMUM WATER FLOW OF 3 GALLONS PER MINUTE AT THE INLET. **MAXIMUM ALLOWABLE INLET WATER PRESSURE IS 125 PSI.** IF DAYTIME PRESSURE IS OVER 80 PSI, NIGHTTIME PRESSURE MAY EXCEED THE MAXIMUM. USE A PRESSURE REDUCING VALVE IF NECESSARY. (ADDING A PRESSURE REDUCING VALVE MAY REDUCE THE FLOW.)

THE SOFTENER WORKS ON 24 VOLT-60 Hz ELECTRICAL POWER ONLY. BE SURE TO USE THE INCLUDED TRANSFORMER, AND PLUG IT INTO A NOMINAL 120V, 60 CYCLE HOUSEHOLD OUTLET THAT IS GROUNDED AND PROPERLY PROTECTED BY A OVERCURRENT DEVICE SUCH AS A CIRCUIT BREAKER OR FUSE. IF TRANSFORMER IS REPLACED, USE ONLY THE AUTHORIZED SERVICE CLASS II, 24 VOLT 10 VA TRANSFORMER.

THIS SOFTENER IS NOT INTENDED TO BE USED FOR TREATING WATER THAT IS MICROBIOLOGICALLY UNSAFE OR OF UNKNOWN QUALITY WITHOUT ADEQUATE DISINFECTION BEFORE OR AFTER THE SOFTENER.



AUTOMATIC WATER SOFTENER

UNPACKING / INSPECTION

The softener is shipped in one master carton. The softeners are completely assembled at the factory, except as required at installation.

Be sure to check the entire softener for any shipping damage or parts loss. Also note damage to the shipping cartons. Contact the transportation company for all

damage and loss claims. The manufacturer is not responsible for damages in transit.

Small parts, needed to install the softener, are in a parts bag. To avoid loss of the small parts, keep them in the parts bag until you are ready to use them.

TABLE OF CONTENTS

	PAGE NO.
WARRANTY, SAFETY GUIDES	2
SPECIFICATIONS, DIMENSIONS	4
BEFORE STARTING INSTALLATION	5
TYPICAL INSTALLATION ILLUSTRATION	6
INSTALLATION STEPS	7 - 9
PROGRAMMING THE TIMER.....	10 - 11
SANITIZING PROCEDURES	12
WATER AND WATER CONDITIONING	13 - 14
HOW THE WATER SOFTENER WORKS	14 - 15
GENERAL WATER SOFTENER MAINTENANCE	16 - 17
ELECTRONIC DEMAND TIMER FEATURES AND SERVICE	
DISPLAYS / OPTIONAL RECHARGE CONTROLS, PROGRAM MEMORY,	
AUTOMATIC ELECTRONIC DIAGNOSTICS	18 - 19
SERVICE CHECKOUT PROCEDURES, WIRING SCHEMATIC	19 - 21
WATER FLOW THROUGH VALVE	22 - 23
REPAIR PARTS	24 - 27



AUTOMATIC WATER SOFTENER

DESIGN SPECIFICATIONS / DIMENSIONS

**MODEL
MW-25**

RATED CAPACITY	See Rating Decal Located On The Softener
RATED EFFICIENCY *	
AMOUNT OF HIGH CAPACITY RESIN (lbs / cu ft)	36.4 / .70
RESIN TANK NOMINAL SIZE (in., dia x height)	8 x 40
SERVICE FLOW RATE (gpm)	See Rating Decal Located On The Softener
PRESSURE DROP AT RATED SERVICE FLOW (psig)	
WATER SUPPLY MAXIMUM HARDNESS (gpg)	70
WATER SUPPLY MAX. CLEAR WATER IRON (ppm) ♦	5
WATER PRESSURE LIMITS (min. / max. psi) ●	20 – 125
WATER TEMPERATURE LIMITS (Min. / Max. °F)	40 – 120
WATER SUPPLY MINIMUM FLOW RATE (gpm)	3
REGENERATION CYCLE FLOW RATES (gpm)	
FILL (flow to brine tank)	.3
BRINING	.15
BRINE RINSE (flow to drain)	.10
MAX. BACKWASH	2.2
MAX. FAST RINSE	2.2

♦ Capacity to reduce clear water iron is substantiated by WQA test data.

These softeners conform to NSF/ANSI 44 for the specific capacity claims as verified and substantiated by test data.

* Efficiency rating is valid only at the minimum stated salt dose. These softeners were efficiency rated according to NSF/ANSI 44.

● Canada working pressure limits: 1.4 – 7.0 kg/cm²

MW-25

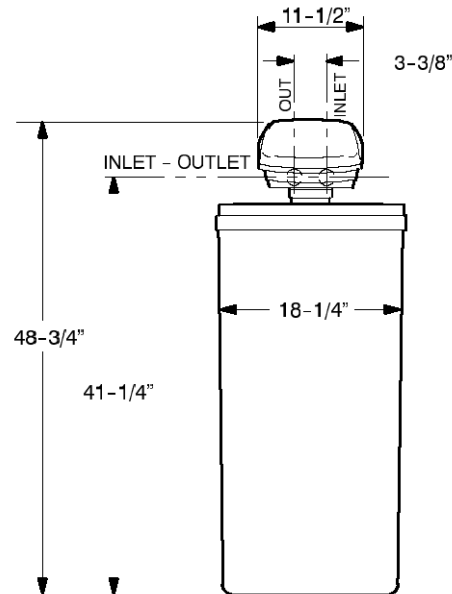



AUTOMATIC WATER SOFTENER

BEFORE STARTING INSTALLATION

► WHERE TO INSTALL THE SOFTENER

- Place the softener as close as possible to the pressure tank (well system) or water meter (city water).
- Place the softener as close as possible to a floor drain, or other acceptable drain point (laundry tub, sump, standpipe, etc.).
- Connect the softener to the main water supply pipe BEFORE or AHEAD OF the water heater. **DO NOT RUN HOT WATER THROUGH THE SOFTENER.** Temperature of water passing through the softener must be less than 120°F (49°C).
- Keep outside faucets on hard water to save soft water and salt.
- Do not install the softener in a place where it could freeze. **Damage caused by freezing is not covered by the warranty.**
- Put the softener in a place water damage is least likely to occur if a leak develops. The manufacturer will not repair or pay for water damage.
- A 120 volt electric outlet, to plug the included transformer into, is needed within 10 feet of the softener. The transformer has a 10 foot power cable. **Be sure the electric outlet and transformer are in an inside location, to protect from wet weather.**
- If installing in an outside location, you must take the steps necessary to assure the softener, installation plumbing, wiring, etc., are as well protected from the elements, contamination, vandalism, etc., as when installed indoors.
- **Keep the softener out of direct sunlight.** The sun's heat will melt plastic parts.

► TOOLS, PIPE and FITTINGS, OTHER MATERIALS YOU WILL NEED

- In and out pipes to the softener must be at least 3/4" size. Some local codes require a minimum of 1" pipe size. *To plumb with 1" pipes, buy adaptors to fit the 1" pipe threads on the installation adaptors or bypass valve (see page 6).* You should maintain the same, or larger, pipe size as the water supply pipe, up to the softener inlet and outlet.
- Use copper, brass, or galvanized pipe and fittings. Some codes may also allow CPVC plastic pipe.
- ALWAYS install a bypass valve or valves. Either use the optional valve (included with some models), or 3 shut-off valves. Bypass valves let you turn off water to the softener for repairs if needed, but still have water in the house pipes.
- Drain hose (3/8" or 7/16" inside diameter) is needed for valve and salt tank drains. You can buy good quality, thick-wall, flexible hose at most hardware stores.
- If a rigid valve drain is needed, to comply with plumbing codes, you can buy the parts needed (see page 8) to connect a 1/2 in. copper tubing drain.
- Nugget or pellet water softener salt is needed to fill the brine tank (see page 9 and 17).

► PLAN HOW YOU WILL INSTALL THE SOFTENER

You must first decide how to run in and out pipes to the softener. Look at the house main water pipe at the point where you will connect the softener. Is the pipe soldered copper, glued plastic, or threaded galvanized? What is the pipe size?

Now look at the typical installation illustration on page 6. Use it as a guide when planning your particular installation. **Be sure to direct raw, hard water to the softener valve inlet fitting.** The valve is marked IN and OUT.

AUTOMATIC WATER SOFTENER

TYPICAL INSTALLATION ILLUSTRATION (BRINE TANK NOT SHOWN)

A ... TO BYPASS VALVE AT SOFTENER

B ... TO COPPER TUBES AT SOFTENER, USING 3-VALVE BYPASS

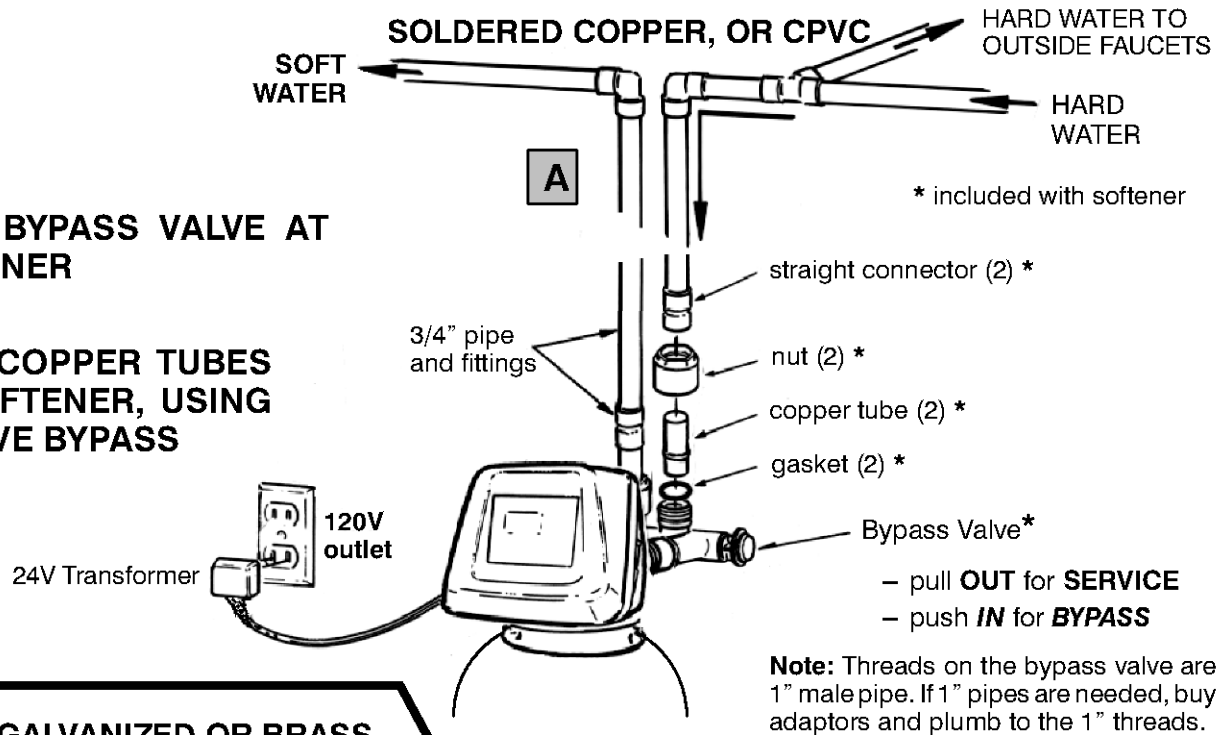

THREADED GALVANIZED OR BRASS

BYPASS – close for service
VALVE – open for bypass

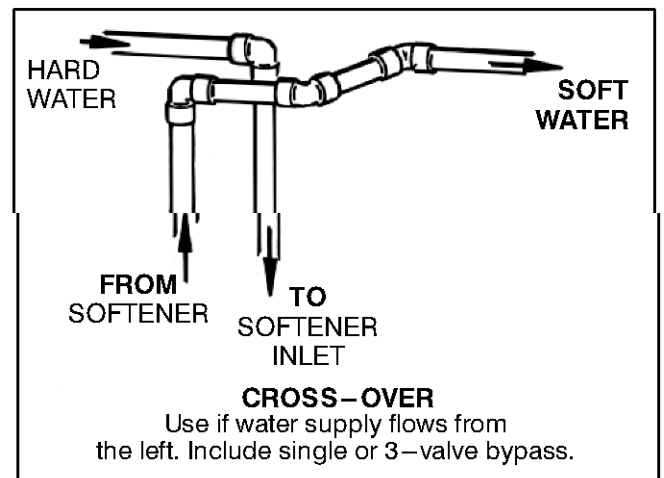
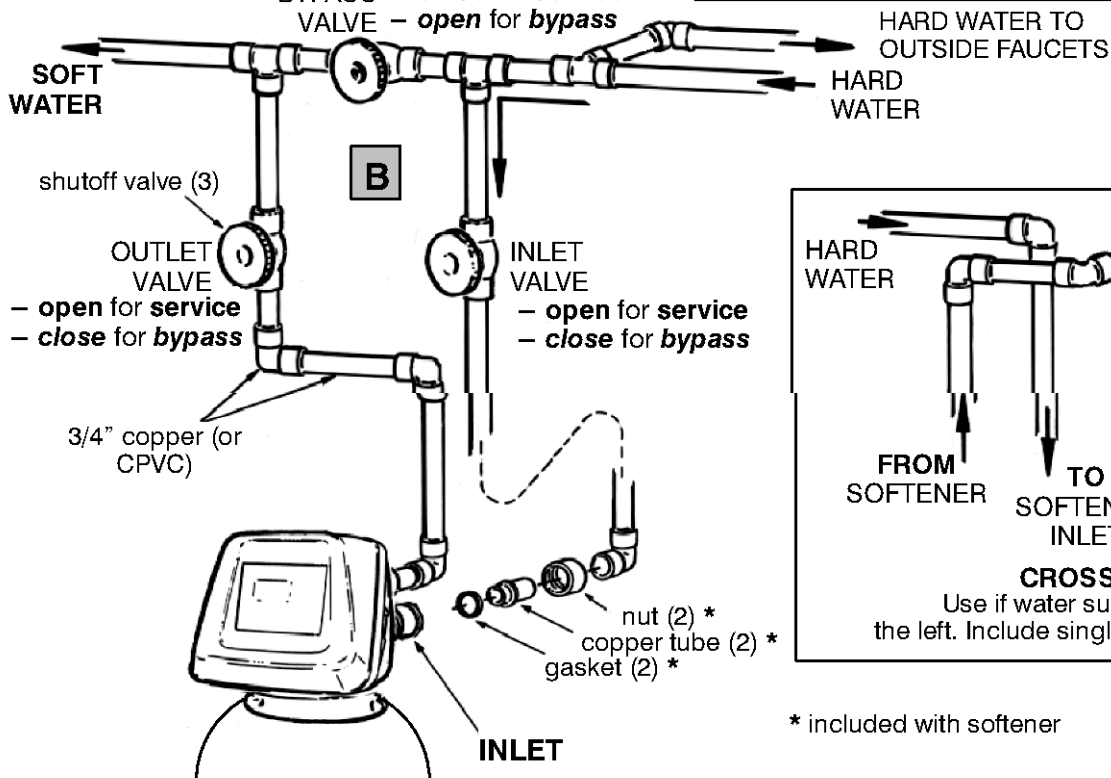

* included with softener

INSTALLATION STEPS

FIGURE 1

1. INSTALL BYPASS VALVE:

NOTE: be sure the turbine and support are firmly in place, in the valve outlet. Blow into the valve port and observe the turbine for free rotation.

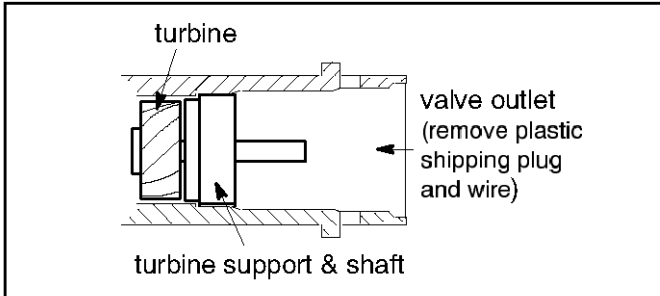

- Push the bypass valve (lubricate o-ring seals) into both ports of the valve...Figures 1A and 1C.
- Snap the two large plastic clips in place, from the top, down...Figures 1A and 1B. **Be sure they snap into place. Pull on the adaptors, or bypass valve, to make sure they held securely in place.**

2. INSTALL THE BRINE TANK OVERFLOW FITTINGS:

- Insert the rubber grommet into the 3/4" diameter hole in the brine tank sidewall...see page 9.
- Push the barbed end of the hose adaptor elbow into the grommet.

3. MOVE THE SOFTENER INTO INSTALLATION POSITION:

- Be sure the installation surface is level and smooth. If needed, place the tank on a section of 3/4" thick (min.) plywood. Then, place shims under the plywood as needed to level the softener.

4. PLUMB IN AND OUT PIPES TO AND FROM SOFTENER:

CAUTIONS: Observe all of the following cautions as you connect inlet and outlet plumbing.

- **Turn off the house water supply valve and open faucets to relieve pressure in the pipes.**
- **BE SURE RAW, HARD WATER IS DIRECTED TO THE VALVE INLET PORT.**
- Be sure to use bypass valve(s).
- If making a soldered copper installation, **do all sweat soldering before connecting pipes to the softener fittings.** Torch heat will damage plastic parts.

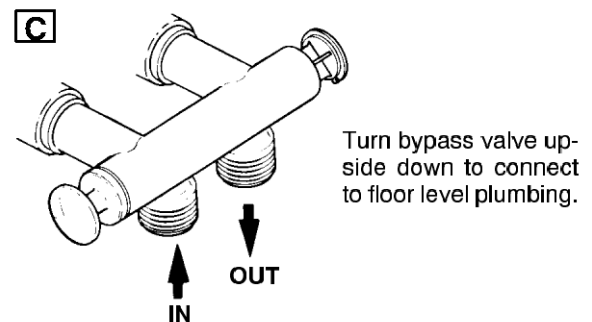
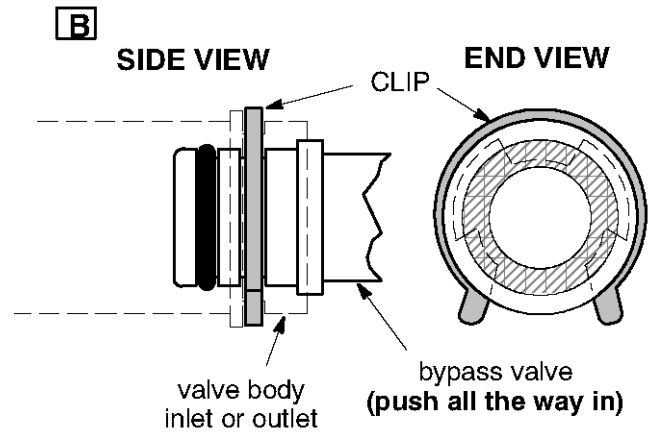
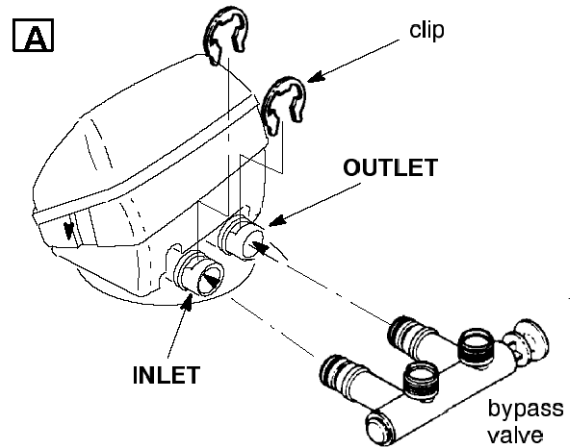

continued

- Put grounding clamps (see step 5) on copper tubes before soldering.
- When turning threaded pipe fittings onto plastic fittings, use care not to cross-thread.
- Use pipe joint compound on all external pipe threads.
- Support inlet and outlet plumbing in some manner (use pipe hangers to keep the weight off the valve fittings).

5. INSTALL GROUNDING CLAMPS AND WIRE (IF NEEDED):

- To maintain electrical ground continuity in the house cold water piping, install the included ground clamps as shown in Figure 2. Be sure the pipes are clean, under the clamps, to assure good contact.

NOTE: A 3-valve bypass system maintains ground continuity.

FIGURE 2

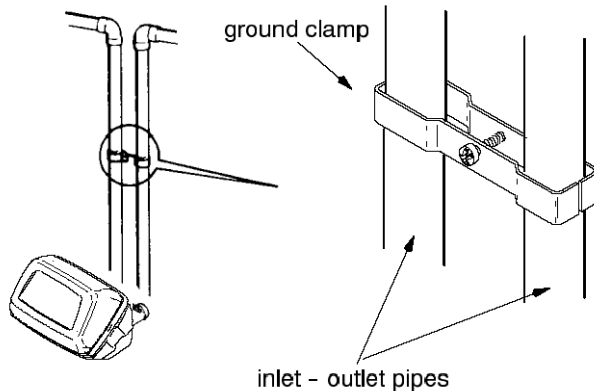

6. CONNECT AND RUN THE VALVE DRAIN HOSE:

- Take a length of 3/8" or 7/16" inside diameter hose and attach to the valve drain fitting. So water pressure does not blow the hose off, use a hose clamp to secure in place.
- Locate the other end of the hose at a suitable drain point...floor drain, sump, laundry tub, etc. **Check and comply with local codes.**

IMPORTANT: Use high quality, thick-wall hose that will not easily kink or collapse. *The water softener will not work if water cannot exit this hose during regenerations.*

- Tie or wire the hose in place at the drain point. Water pressure will cause it to whip during the backwash and fast rinse cycles of regeneration. Also provide an air gap of at least 1-1/2" between the end of the hose and the drain point. An air gap prevents possible siphoning of sewer water, into the softener, if the sewer should "back-up".
- If raising the drain hose overhead is required to get to the drain point, **do not raise higher than 8' above the floor.** Elevating the hose may cause a back-pressure that could reduce brine draw during regenerations.

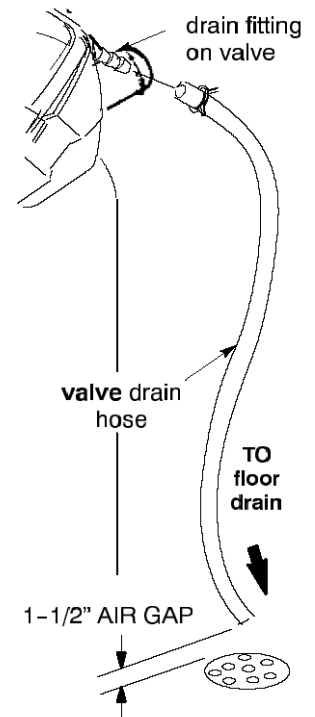

CONNECTING A RIGID VALVE DRAIN TUBE

To adapt a copper drain tube to the softener, use a hacksaw to cut the barbed end from the drain fitting as shown. Buy a compression fitting (1/4" female pipe thread x 1/2" O.D. tube) and needed tubing from your local hardware store.

FIGURE 3

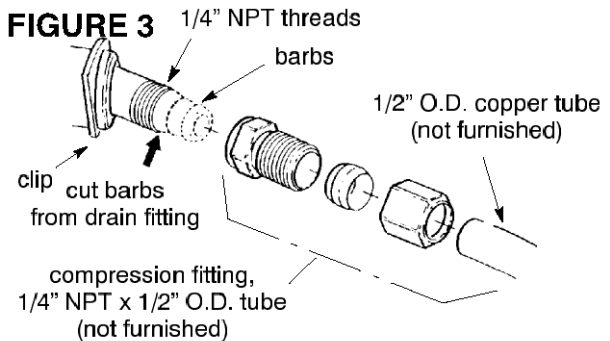

7. CONNECT AND RUN THE BRINE TANK OVERFLOW HOSE (see Figure 4)

- **NOTE:** Move the softener into installation location.
- Attach a length of 3/8" or 7/16" I.D. hose to the drain elbow, installed in step 2, page 7. Use a hose clamp to hold it in place.



AUTOMATIC WATER SOFTENER

INSTALLATION STEPS, continued

► Locate the other end of the hose at the drain point. **DO NOT ELEVATE THIS HOSE HIGHER THAN THE ELBOW ON THE BRINE TANK. DO NOT TEE THIS HOSE TO THE VALVE DRAIN HOSE.**

NOTE: This drain is for safety only. If the brine tank should over-fill with water, the excess is carried to the drain.

8. FLUSH PIPES, EXPEL AIR FROM SOFTENER, AND TEST YOUR INSTALLATION FOR WATER LEAKS:

CAUTION: To avoid water or air pressure damage to softener inner parts, be sure to do the following steps exactly as listed.

A. Fully open two cold, **soft** water faucets nearby by the softener.

B. Place bypass valve(s) in “**bypass**” position. On a single valve, slide the stem into BYPASS. On a 3-valve system, close the inlet and outlet valves, and open the bypass valve...see page 6.

C. Fully open the house main water pipe shutoff valve. Observe a steady flow from both opened faucets.

D. Place bypass valve(s) in “**service**”, **EXACTLY** as follows. **KEEP SOFT WATER FAUCETS OPEN.**

1. SINGLE BYPASS VALVE: **SLOWLY**, slide the valve stem toward “service”, pausing several times to allow the softener to pressurize slowly.

2. 3-VALVE BYPASS: Fully close the bypass valve and open the outlet valve. **SLOWLY**, open the inlet valve, pausing several times to allow the softener to pressurize slowly.

E. After about three minutes, open a **HOT** water faucet for one minute, or until all air is expelled, then close.

F. Close both cold water faucets.

G. Check your plumbing work for leaks and fix right away, if any are found. **BE SURE TO OBSERVE PREVIOUS CAUTION NOTES.**

H. Turn on the gas or electric supply to the water heater. Light the pilot, if applicable.

9. ADD WATER AND SALT TO THE BRINE TANK:

► Remove the salt storage area cover. Add about 3 gallons of water into the tank. **DO NOT ADD INTO THE BRINEWELL.**

► *Add NUGGET, PELLET or coarse SOLAR water softener salt to the salt storage tank. **Do not use** rock, block, granulated, and ice cream making salts. Also see page 16. Maximum salt storage capacity is 200 lbs.

*Note: If the softener is installed in a humid basement or other damp area, it is better to fill the tank more often using less salt (see salt bridging in the maintenance section). Eighty to 100 lbs of salt will last for several months, depending on water hardness, family size, and model of softener.

10. CONNECT TO ELECTRICAL POWER:

► The softener works on 24 volt, 60 Hz electric power. The included transformer changes standard 120 volt AC house power to 24 volts. **Plug the transformer into a 120 volt outlet only.** Be sure the outlet is always “live” so it can not be switched off by mistake.

Plug the transformer into the electrical outlet.

11. PROGRAM THE TIMER:

► **ELECTRONIC DEMAND TIMER...**see pages 10 and 11.

PROGRAMMING THE ELECTRONIC DEMAND TIMER

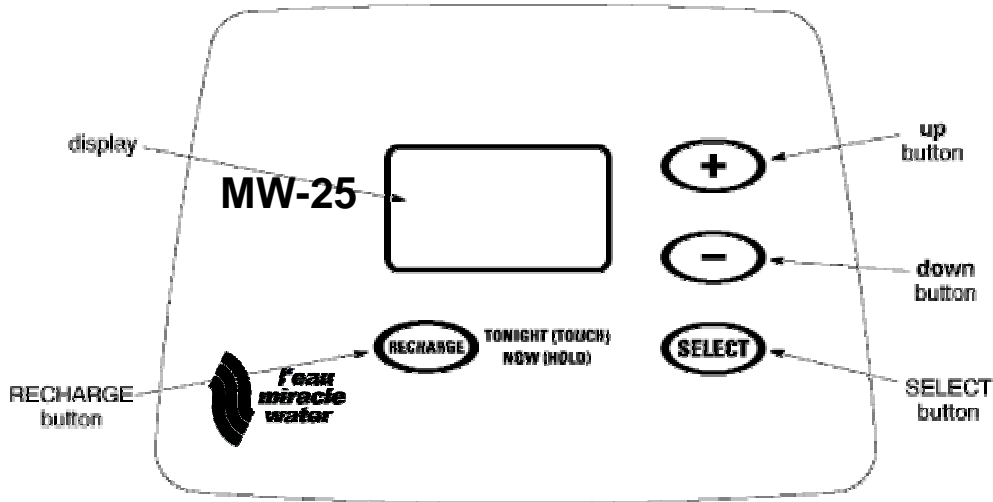

► **TIMER SETTINGS REQUIRED**...upon installation, and after an extended power outage (see Program Memory, page 18).

NOTES:

- WHEN THE TRANSFORMER IS PLUGGED INTO THE ELECTRICAL OUTLET (STEP 11, PAGE 9), a flashing **12:00AM** and **PRESENT TIME** show in the display area. Program the timer as instructed below. **If SR - - is flashing**, use the UP + button to set the code to **SR20**. If you pass be the correct code number, use the DOWN – button. Then, press the SELECT button and program the timer below. *If the wrong SR code shows for your model, see Manual Initiated Electronic Diagnostics on pages 19 and 20.*
- A “beeper” sounds while pressing buttons for timer programming. One beep signals a change in the timer display. Repeated beeps means the timer will not accept a change from the button you have pressed, and you should use another button.
- To set the timer, you will use the UP +, DOWN – and SELECT buttons.

► **SET TIME OF DAY, AND PRESENT DAY OF WEEK**

NOTE: If the words *PRESENT TIME* do not show in the display, press the SELECT button until they do.

1. Press the UP or DOWN button to set. The UP button moves the display ahead; the DOWN button moves the time backward.

NOTE: Each press of the buttons changes the time by one minute. Holding the buttons in changes the time 32 minutes each second.

If the present time is between noon and midnight, be sure PM shows.



If the present time is between midnight and noon, be sure AM shows.

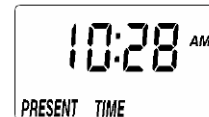

2. When the present time shows, press SELECT to set.



AUTOMATIC WATER SOFTENER

PROGRAMMING THE ELECTRONIC DEMAND TIMER, continued

► SET WATER HARDNESS NUMBER

NOTE: If a flashing 25 (factory default) and the word HARDNESS do not show in the display, press SELECT until they do.

1. Press the UP or DOWN button to set your water hardness number in the display. DOWN moves the display down to 1. UP moves the display up to 95.

NOTE: Each press of a button changes the display by 1 between 1 and 25. Above 25, the display changes 5 at a time; 25, 30, 35, etc. Holding a button in changes the numbers twice each second. See the specified maximum hardness, page 4.

2. When your water hardness number shows, press SELECT to set.



You can get the grains per gallon (gpg) hardness of your water supply from a water analysis laboratory, or call and ask your local water department, if you are on a municipal supply. If water contains iron, add to the water hardness at a ratio of 5 grains for each 1 ppm of iron.

► SET REGENERATION (STARTING) TIME

NOTE: RECHARGE TIME and a flashing 2:00 AM (factory default) should show in the display. This is a good time for regeneration to start (over in about 2 hours) in most households because water is not in use. HARD WATER is bypassed to house faucets during regeneration. ... See Automatic Bypass on page 14.

If no change is needed, go to step 2. To change this time, if desired, do step 1.

1. Press the UP or DOWN button to set the desired regeneration start time.

Be sure to observe the AM or PM, as you did when setting the time of day.



NOTE: Each press of the buttons changes the time by one hour. Holding the buttons in changes the time twice each second.

2. Press the SELECT button once more.

The display shows the present time of day.

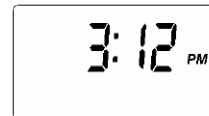

The special *features* of your timer are explained on page 18.

TO COMPLETE THE INSTALLATION, GO TO THE SANITIZING PROCEDURES ON PAGE 12.



AUTOMATIC WATER SOFTENER

SANITIZING PROCEDURES

Care is taken at the factory to keep your water softener clean and sanitary. Materials used to make the softener will not infect or contaminate your water supply, and will not cause bacteria to form or grow. However, during shipping, storage, installing and operating, bacteria could get into the softener. For this reason, sanitizing as follows is suggested^① when installing.

1. Be sure to complete all installation steps, including timer programming.

2. Pour about 3/4 oz of common 5.25% household bleach (Clorox, etc.,) **into the brinewell**.

3. Use the REGENERATE, OR RECHARGE, NOW feature, on the timer, to start an immediate regeneration. The bleach is drawn into and through the water softener to sanitize it. This sanitizing regeneration is over in about 2 hours. Then, **soft water** is available for your use.

^① NOTE: Sanitizing is recommended by the water Quality Association for disinfecting. On some water supplies, they suggest periodic sanitizing.

NOTE: When the above sanitizing regeneration is over, all remaining bleach is flushed from the conditioner and your house COLD water supply is fully soft immediately. However, **your water heater is filled with hard water** and, as hot water is used, it will refill with soft water. When all the hard water is replaced, in the water heater, hot only, and mixed hot and cold water will be fully soft. If you want totally soft water immediately, after the above regeneration, drain the water heater until the water runs cold. **If you do drain the water heater, use extreme care as the water could cause severe burns.**



AUTOMATIC WATER SOFTENER

WATER AND WATER CONDITIONING

WATER.....

Man's very existence depends on water. It is one of the basic commodities of life. Water is best as nature provides it, is a common misconception. Practically all natural water needs refinement or treatment to make it safe to drink or more satisfactory to use.

The earth's water supply cycle starts in the upper cloud layers. As it falls to the earth as rain or snow, it picks up impurities and gases from the atmosphere. Landing on earth, it seeps over and through the ground, dissolving earth minerals. Passing through limestone, it dissolves calcium and magnesium, the hardness minerals. Iron deposits impart iron to the water. Acidity and sediments are other water conditions.

WATER CONDITIONING.....

Water conditioning is the treatment of four general conditions. These are: *Hardness, Iron, Acidity, Sediments.*

HARDNESS is a term to describe the presence of calcium and magnesium minerals in water. A chemical analysis accurately measures the amount of minerals in grain weight. For example, one gallon of water with five grains per gallon (gpg) hardness has dissolved minerals, that if solidified, about equals the size of one ordinary aspirin tablet. One gallon of water, 25 gpg hard, has a mineral content equal in size to five aspirin tablets. Water hardness varies greatly across the country. It generally contains from 3 to 100 gpg.

Hard water affects living in general. Hardness minerals combine with soap to make a soap curd. The curd greatly reduces the cleaning action of soap. Precipitated hardness minerals form a crust on cooking utensils, appliances, and plumbing fixtures. Even the tastes of foods are affected. A water softener removes the hardness minerals to eliminate these problems, and others.

Sodium Information: Water softeners using sodium chloride (salt) for regeneration add sodium to the water. Persons on sodium restricted diets should consider the added sodium as part of their overall intake.

IRON in water is measured in parts per million (ppm). The total* ppm of iron, and type or types*, is

Municipal water supplies come from surface reservoirs, such as lakes and rivers, or from underground reservoirs. Usually, municipalities chlorinate the water to make it safe to drink. Sediment is removed by filtration. Tastes and odors are reduced or eliminated. The water is conditioned to comply with certain specifications. However, hardness minerals, tastes and odors are not always reduced to the most desirable levels.

Underground reservoirs provide our private water supplies. Because the water is raw and untreated, it can have varying amounts of hardness, iron, tastes, odors, acidity, or combinations of these. Different localities and water levels affect mineral content.

determined by chemical analysis. Four different types of iron in water are: ① Ferrous (clear water), ② Ferric (red water), ③ Bacterial and organically bound iron, ④ Colloidal and inorganically bound iron (ferrous or ferric).

*Water may contain one or more of the four types of iron and any combination of these. Total iron is the sum of the contents.

① Ferrous (clear water) iron is soluble and dissolves in water. It is usually detected by taking a sample of water in a clear bottle or glass. Immediately after taking, the sample is clear. As the water sample stands, it gradually clouds and turns slightly yellow or brown as air oxidizes the iron. This usually occurs in 15 to 30 minutes. A water softener will remove moderate amounts of this type of iron (see specifications).

② Ferric (red water), and ③ Bacterial and organically bound irons are insoluble. This iron is visible immediately when drawn from a faucet because it has oxidized before reaching the home. It appears as small cloudy yellow, orange, or reddish suspended particles. After the water stands for a period of time, the particles settle to the bottom of the container. Generally these irons are removed from water by filtration. Chlorination is also recommended for bacterial iron.

continued



AUTOMATIC WATER SOFTENER

WATER AND WATER CONDITIONING, continued

④ Colloidal and inorganically bound iron is of ferric or ferrous form that will not filter or exchange out of water. In some instances, treatment may improve colloidal iron water, but always CONSULT A QUALIFIED WATER CHEMISTRY LAB before attempting to treat it. Colloidal iron water usually has a yellow appearance when drawn. After standing for several hours, the color persists and the iron does not settle, but remains suspended in the water.

Iron in water causes stains on clothing and plumbing fixtures. It negatively affects the taste of food, drinking water, and other beverages.

ACIDITY or acid water is caused by carbon dioxide, hydrogen sulfide, and sometimes industrial wastes. It is corrosive to plumbing, plumbing fixtures, water heaters,

and other water using appliances. It can also damage and cause premature failure of seals, diaphragms, etc., in water handling equipment.

A chemical analysis is needed to measure the degree of acidity in water. This is called the pH of water. Water testing below 6.9 pH is acidic. The lower the pH reading, the greater the acidity. A neutralizer filter or a chemical feed pump are usually recommended to treat acid water.

SEDIMENT is fine, foreign material particles suspended in water. This material is most often clay or silt. Extreme amounts of sediment may give the water a cloudy appearance. A sediment filter normally corrects this condition.

HOW THE WATER SOFTENER WORKS

SOFT WATER SERVICE, AND REGENERATION ...see illustrations, page 15

SERVICE

When the softener is providing soft water, it is called "Service". During service, hard water flows from the house main water pipe into the softener. Inside the softener resin tank is a bed made up of thousands of tiny, plastic resin beads. As hard water passes through the bed, each bead attracts and holds the hardness minerals. This is called ion-exchanging. It is much like a magnet attracting and holding metals. Water without the hardness minerals (soft water) flows from the softener and to the house pipes.

After a period of time, the resin beads hold all of the hardness minerals they can and cleaning is needed to remove them. This cleaning is called regeneration, or recharge. The demand timer automatically determines when regenerations occur. Regeneration is started at 2:00 a.m. (factory setting) by the softener timer, and consists of 5 stages or cycles. These are: FILL, BRINING, BRINE RINSE, BACKWASH, and FAST RINSE.

REGENERATION

● **FILL:** Salt, dissolved in water, is called brine. Brine is needed to clean the hardness minerals from the resin beads. To make the brine, water flows into the salt storage area during the fill stage as shown on page 15.

AUTOMATIC HARD WATER BYPASS DURING REGENERATION.....

For emergency needs, **hard** water is available to the home during the regeneration cycles. However, you

● **BRINING:** During brining, brine travels from the salt storage area, into the resin tank. Brine is the cleaning agent needed to remove the hardness minerals from the resin beads. The hardness minerals, and brine are discharged to the drain.

The nozzle and venturi create a suction to move the brine, maintaining a very slow rate to get the best resin cleaning with the least salt.

● **BRINE RINSE:** After a pre-measured amount of brine is used, the brine valve closes. Water continues to flow in the same path as during brining, except for the discontinued brine flow. Hardness minerals and brine flush from the resin tank, to the drain.

● **BACKWASH:** During backwash, water travels **up** through the resin tank at a fast flow rate, flushing accumulated iron, dirt, and sediments from the resin bed and to the drain.

● **FAST RINSE:** Backwash is followed by a fast flow of water **down** through the resin tank. The fast flow flushes brine from the bottom of the tank, and packs the resin bed.

After fast rinse, the softener returns to soft water service.

should avoid using **HOT** water because the water heater will refill with the hard water.

WATER FLOW THROUGH SOFTENER

SOFT WATER SERVICE

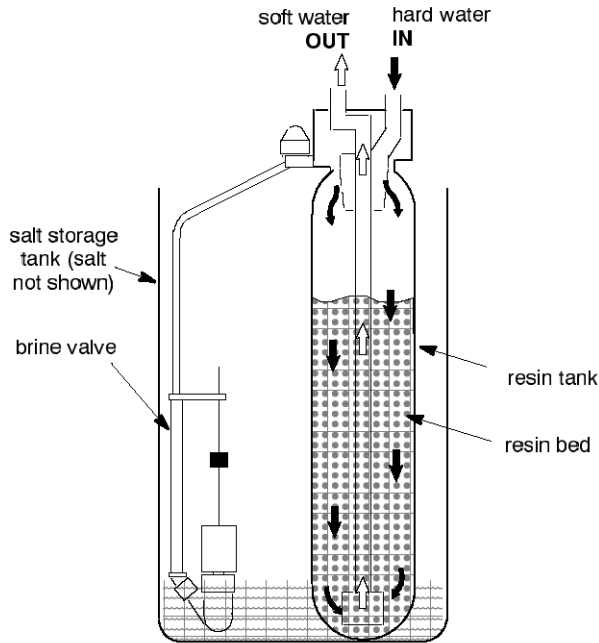

FILL

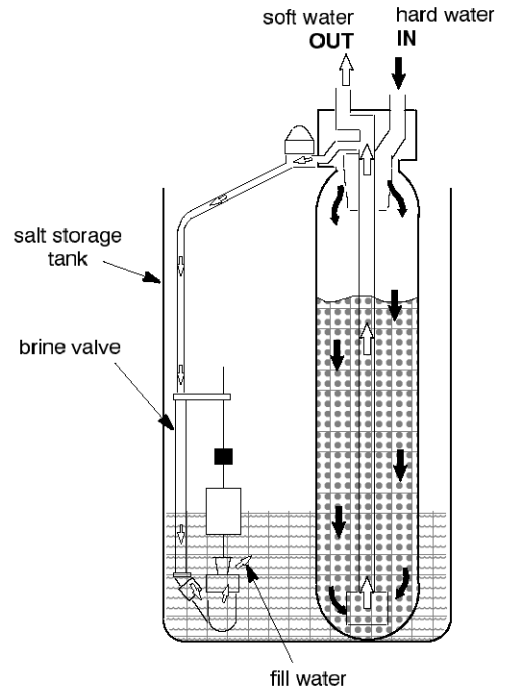

BRINING / BRINE RINSE

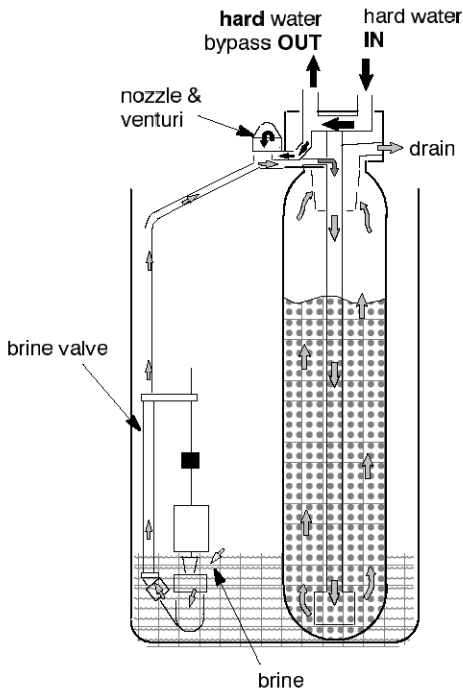

BACKWASH

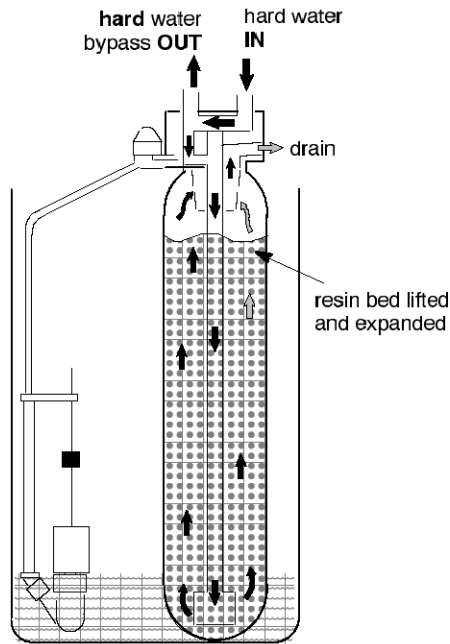

FAST RINSE

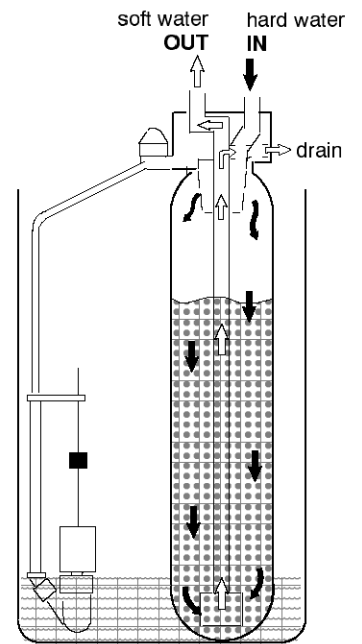

GENERAL WATER SOFTENER MAINTENANCE

CHECKING THE SALT STORAGE LEVEL, AND REFILLING

Brine (salt dissolved in water) is needed for each and every regeneration. The water for making brine is metered into the salt storage area by the softener valve and timer. However, you must keep the tank full of salt.

NOTE: In humid areas, it is best to fill with less salt, more often.

WHEN TO ADD SALT: *Check the salt level a few weeks after you install the softener and every week after that. Add when the brine tank is from 1/3 to 1/2 full. Never allow the softener to use all the salt before you add more. Without salt, you will soon have hard water.*

Use clean water softener salt only, at least 99.5% pure. NUGGET, PELLET or coarse SOLAR salts are recommended. Do not use rock, block, granulated, and ice cream making salts. They contain dirt and sediments, or mush and cake, and will create maintenance problems.

NOTE: WATER SOFTENING SALT WITH IRON REMOVING ADDITIVES: Some salts have an additive to help the softener handle iron in the water supply. Although this additive may help to keep the softener resin clean, it may also release corrosive fumes that weaken and shorten the life of some softener parts.

BREAKING A SALT BRIDGE.....

Sometimes, a hard crust or salt bridge forms in the salt storage area. It is usually caused by high humidity or the wrong kind of salt. When the salt bridges, an empty space forms between the water and salt. Then salt will not dissolve in the water to make brine.

If the brine tank is full of salt, it is hard to tell if you have a salt bridge. Salt is loose on top, but the bridge is under it. The following is the best way to check for a salt bridge.

Salt should be loose all the way to the bottom of the tank. Take a broom handle, or like tool, and **carefully** push it down into the salt, working it up and down. If the tool strikes a hard object (be sure it's not the bottom or sides of the tank), it's most likely a salt bridge. Carefully break the bridge with the tool. DO NOT pound on the walls of the tank.

If the wrong kind of salt made the bridge, take it out. Then fill the tank with nugget, pellet or coarse solar salt only. In humid areas, it is best to fill with less salt, more often.

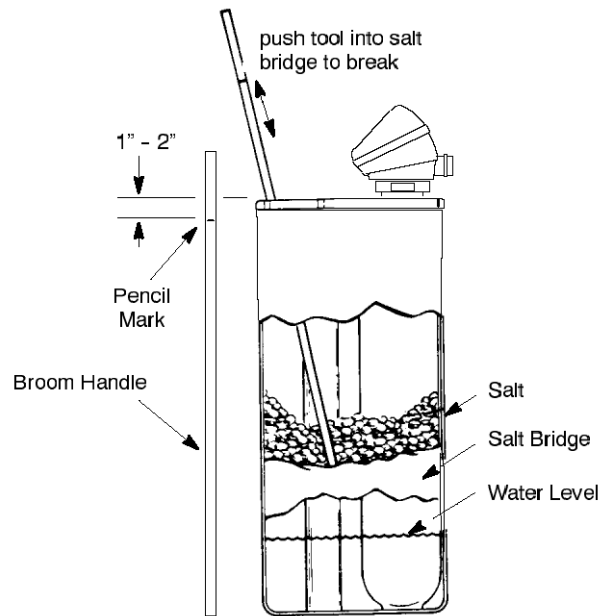

CLEANING IRON OUT OF THE WATER SOFTENER.....

Your water softener takes hardness minerals (calcium and magnesium) out of the water. Also, it can control some (see specifications, page 4) "clear water" iron. With clear water iron, water from a faucet is clear when first put into a glass. After 15 to 30 minutes, the water begins to cloud or turn rust colored. A water softener WILL NOT remove any iron that makes the water cloudy or rusty as it comes from the faucet (called red water iron). To take red water iron out of water, or over

the maximum of clear water iron, an iron filter or other equipment is needed. Your local dealer has trained people to help you with iron water problems.

If your water supply has clear water iron, periodic resin bed cleaning is needed. Clean the bed at least every 6 months, or more often if iron appears in the soft water between treatments. Follow directions on the resin bed cleaner container.

GENERAL WATER SOFTENER MAINTENANCE, continued

CLEANING THE NOZZLE AND VENTURI ASSEMBLY.....

A clean nozzle and venturi is needed for the softener to work right. This small unit makes the suction to move brine from the salt storage area to the resin tank during regeneration. If it becomes plugged with sand, silt, dirt, etc., the softener will not work and you will get hard water.

To get to the nozzle and venturi, remove the softener top cover. Be sure the softener is in service cycle (no water pressure at nozzle and venturi). Then, while holding the nozzle & venturi housing with one hand, turn off the cap. Lift out the screen support and screen, then the nozzle and venturi. Wash and rinse the parts in warm water until clean. If needed, use a small brush to remove iron or dirt. Also check and clean the gasket.

NOTE: Some models have a small flow plug located in the nozzle and venturi, and/or a small cone shaped screen in the housing. Be sure to check and clean these parts, if your model is so equipped.

Carefully replace all parts in the correct order. Lubricate the o-ring seal with silicone grease and place in position. Install and tighten the cap, BY HAND ONLY. DO NOT OVER-TIGHTEN AND BREAK THE CAP OR HOUSING.

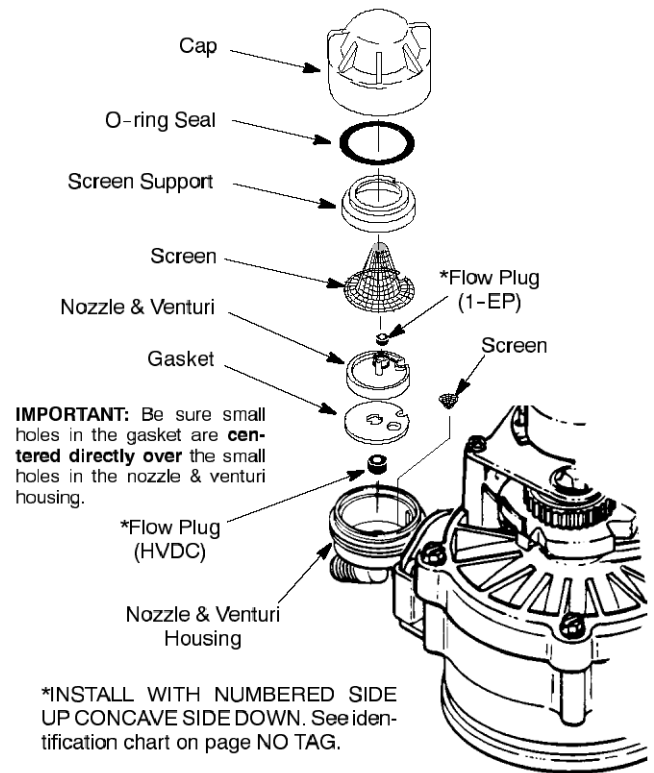

SERVICE CHECKLIST

NO SOFT WATER

- **No salt in storage tank:** See page 16 to add, then start a regeneration, or recharge.
- **Transformer unplugged at wall outlet, or disconnected from timer:** Reconnect to electrical power and start a regeneration, or recharge.
- **Fuse blown, circuit breaker popped, or circuit mistakenly switched off:** Check and resolve as needed. Then, start a regeneration, or recharge.
- **Plumbing bypass valve(s) in “bypass” position:** Refer to page 6 and position valve(s) as needed to direct soft water to house pipes. Then, start a regeneration, or recharge.
- **Timer not programmed:** See... Electronic Demand Timer - page 10.
- **Nozzle & venturi dirty, or salt in storage tank bridged:** See page 16 and above to clean. Then, start a regeneration, or recharge.

WATER INTERMITTENTLY HARD

- **Possible increase in water hardness:** See...
Electronic Demand Timer - page 11.
- **Hot water used when softener is regenerating:** The water heater will refill with hard water... see Automatic Hard Water Bypass During Regenerations, page 14.
- **Leaking faucet or toilet valve:** A small leak will waste hundreds of gallons of water in just a few days. Fix all water leaks immediately.



AUTOMATIC WATER SOFTENER

ELECTRONIC DEMAND TIMER FEATURES, AND SERVICE

NOTE: SEE PAGE 10 TO SET THE TIMER TO THE CORRECT TIME OF DAY, WATER HARDNESS NUMBER, AND RECHARGE START TIME.

NORMAL OPERATION, TIMER DISPLAYS

During normal operation, the present time of day, and AM or PM, show in the time display area.

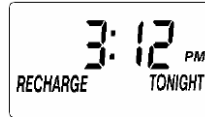

feature: OPTIONAL RECHARGE CONTROLS

Sometimes, a manually started regeneration (recharge) may be desired, or needed. Two examples are:
... You have used more water than usual (house guests, extra washing, etc.) and you may run out of soft water before the next regeneration.
... You did not refill the storage tank with salt before it was all gone.

Use one of the following features to start a regeneration immediately, or at the next preset regeneration start time.

RECHARGE NOW

Press and **hold** in the RECHARGE button until **RECHARGE NOW** starts to flash in the time display area. The softener begins an immediate regeneration, and when over in about two hours, you will have a new supply of soft water. Once started, you cannot cancel this regeneration.

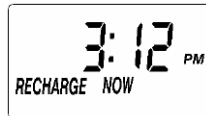

RECHARGE TONIGHT

Press and release the RECHARGE button, and **RECHARGE TONIGHT** flashes in the time display area. A regeneration will occur at the next preset regeneration start time. If you decide to cancel this regeneration, touch the same button once more.

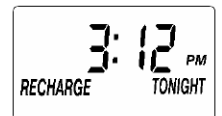

VACATION NOTE

MW-25 Demand water softeners regenerate only while water is used and softening capacity must be restored. For this reason, the softener will not regenerate when you are away from home for extended periods.

feature: PROGRAM MEMORY

If electrical power to the softener is interrupted, the time display is blank, but the timer keeps correct time for about 6 hours. When power is restored, you have to reset the present time **only if** the display is flashing. **All** other settings are maintained and never require resetting unless a change is desired.

If the time *is* flashing after a long power outage, the softener continues to work as it should to provide you with soft water. However, regenerations may occur at the wrong time of day until you reset the timer to the correct time of day, page 10.

feature: SALT EFFICIENCY

When this feature is ON, the unit will operate at salt efficiencies of 4000 grains of hardness per pound of salt or higher. (May recharge more often using smaller salt dosage and less water). Press and hold the SELECT button for 3 seconds until the following screen is displayed.

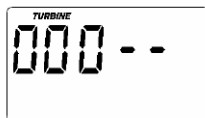

Press SELECT once more to return to normal operating screens. When this is ON the efficiency icon  will show in the upper right hand corner of the display.

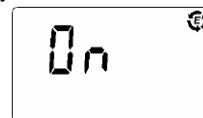

Press and release the SELECT button once and the SALT EFFICIENCY display shows. Use the UP / DOWN buttons to change the ON / OFF displays.



AUTOMATIC WATER SOFTENER

ELECTRONIC DEMAND TIMER FEATURES, AND SERVICE, continued

California Efficiency Requirement

Your water softener has a “High Efficiency” feature with an “ON” or “OFF” setting. This softener setting is shipped in the “OFF” position, which utilizes the maximum rated capacity while most often achieving maximum salt efficiencies. When installing this unit in the State of California, you MUST turn this setting to the “ON” position which may initiate more frequent recharges, however it will operate at 4000 grains per pound of salt or higher.

If you wish to turn the Salt Efficiency feature “ON” ( icon will show in display), follow the instructions on page 18.

feature / service: AUTOMATIC ELECTRONIC DIAGNOSTICS

The timer computer has a self-diagnostic function for the electrical system (except input power and water meter). The computer monitors the electronic components and circuits for correct operation. If a malfunction occurs, an error code appears in the timer display.

The following chart (below) shows the error codes that could appear, and possible defects for each code.

While an error code is displayed, all timer buttons are inoperable except for the SELECT button. SELECT remains operational so the service person can make the Manual Initiated Electronic Diagnostics to further isolate the defect, and check the water meter.

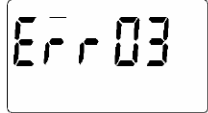

	ERROR CODE DISPLAYED			
	Err 01	Err 03	Err 04	Err 05
POSSIBLE DEFECT	<ul style="list-style-type: none"> ➔ wiring harness, or connection to switch ➔ valve defect causing high torque 	<ul style="list-style-type: none"> ➔ position switch 	<ul style="list-style-type: none"> ➔ motor inoperative 	<ul style="list-style-type: none"> ➔ timer (PWA)
	TO REMOVE AN ERROR CODE: (1) unplug transformer (2) correct defect (3) plug transformer in (4) Wait for at least 12 minutes. The error code will return if the reason for the error code was not corrected.			

service: TIMER / SOFTENER, SERVICE CHECKOUT PROCEDURE.....

If you are not getting soft water, and an error code is not displayed, use the procedures below to find the problem. First, make the following visual checks.

VISUAL CHECKS: (1) Is there electrical power to the outlet the softener transformer is plugged into? (2) Is there salt in the storage tank? (3) Is the plumbing

bypass valve(s) directing water for soft water service? - see page 6- (4) Is the valve drain hose open to the drain, not elevated too high, and unobstructed? If you do not find a problem with the visual checks, continue below.

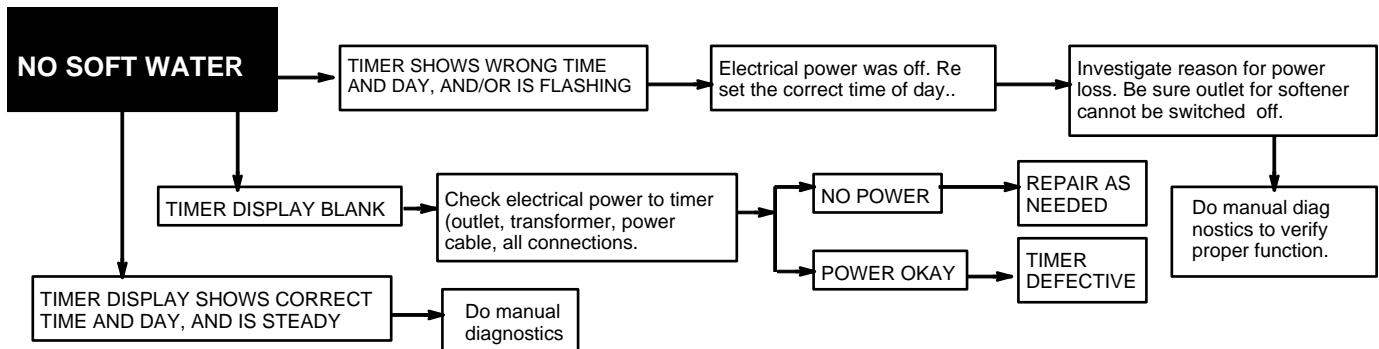

ELECTRONIC DEMAND TIMER FEATURES, AND SERVICE, continued

service: MANUAL INITIATED ELECTRONICS DIAGNOSTIC.....

1. To enter diagnostics, press and hold the SELECT button until (000 - -) shows in the display.

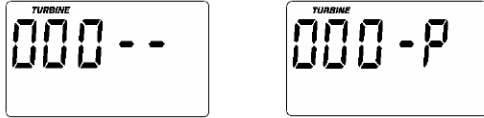

(A) The first 3 digits indicate water meter operation as follows:

➔ 000 (steady) = soft water not in use...no flow through the meter.

— OPEN A NEARBY SOFT WATER FAUCET —

➔ 000 to 199 (continual) = repeats display for each gallon of water passing through the meter.

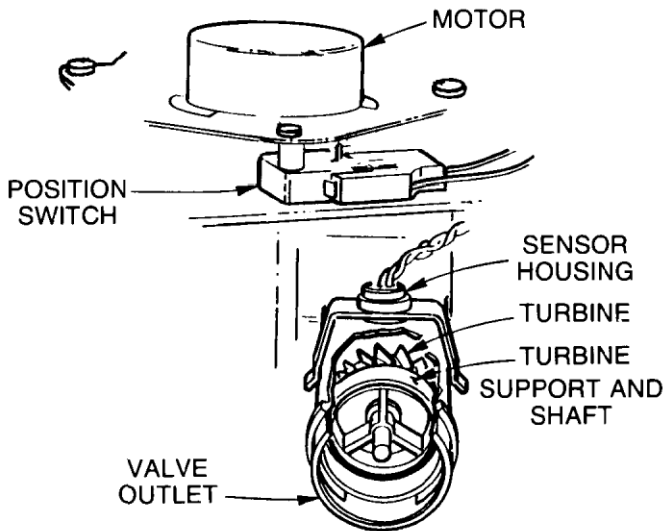

If you don't get a reading in the display, with faucet open, pull the sensor from the valve outlet port. Pass a small magnet back and forth in front of the sensor. You should get a reading in the display. If you get a reading, unhook the in and out plumbing and check the turbine for binding.

(B) The letter (P) and dash(es) indicate POSITION switch operation. The letter appearing means the switch is closed; the dash means the switch is open.

Use the RECHARGE button to manually advance the valve into each cycle and check correct switch operation.

CORRECT SWITCH DISPLAYS	VALVE CYCLE STATUS
- -	Valve in service, fill, brining, backwash or fast rinse position.
- P	Valve rotating from one position to another.

(C) While in this diagnostic screen, the following information is available and may be beneficial for various reasons. This information is retained by the computer from the first time electrical power is applied to the face plate.

...Press the UP button to display the number of days this face plate has had electrical power applied.



...Press the DOWN button to display the number of regenerations initiated by this face plate since the model code number was entered.

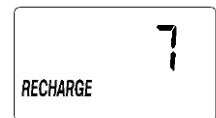

2. Press the SELECT button and hold in 3 seconds until a model code appears in the display.



For correct softener operation, the SR number must be SR20.

To reset the code, press the UP or DOWN button until the correct number shows.

3. Press SELECT to return the present time display. If the code was changed, make ALL the timer settings, pages 10 and 11.

NOTE: If the face plate is left in a diagnostic display (or a flashing display when setting times or hardness), present time automatically returns if a button is not pressed within 4 minutes.

ELECTRONIC DEMAND TIMER FEATURES, AND SERVICE, continued

service: MANUAL ADVANCE REGENERATION CHECK.....

This check verifies proper operation of the valve motor, brine tank fill, brine draw, regeneration flow rates, and other controller functions. **First, make the initial checks, and the manual initiated diagnostics.**

NOTE: The face plate display must show a steady time (not flashing).

1. Press the RECHARGE button and *hold* in for 3 seconds. RECHARGE NOW begins to flash as the softener enters the fill cycle of regeneration. Remove the brinewell cover and, using a flashlight, observe fill water entering the brine tank.

➡ If water **does not** enter the tank, look for an obstructed nozzle, venturi, fill flow plug, brine tubing, or brine valve riser pipe.

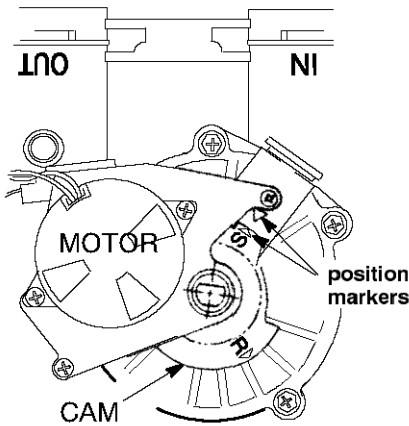

2. After observing fill, press the RECHARGE button to move the softener into brining. A slow flow of water to

the drain will begin. Verify brine draw from the brine tank by shining a flashlight into the brinewell and observing a noticeable drop in the liquid level.

NOTE: Be sure a salt bridge is not preventing water with salt contact.

➡ If the softener does not draw brine...

- ...nozzle and/or venturi dirty or defective.
- ...nozzle and venturi not seated properly on gasket.
- ...restricted drain (check drain fitting and hose).
- ...defective nozzle and venturi seal.
- ...other inner valve defect (rotor seal, rotor & disc, wave washer, etc.).

NOTE: If water system pressure is low, an elevated drain hose may cause back pressure, stopping brine draw.

3. Again, press the RECHARGE button to move the softener into backwash. Look for a fast flow of water from the drain hose.

➡ A slow flow indicates a plugged top distributor, backwash flow plug, or drain hose.

4. Press RECHARGE to move the softener into fast rinse. Again look for a fast drain flow. Allow the softener to rinse for a few minutes to flush out any brine that may remain in the resin tank from the brining cycle test.

5. To return the softener to service, press RECHARGE.

WIRING SCHEMATIC

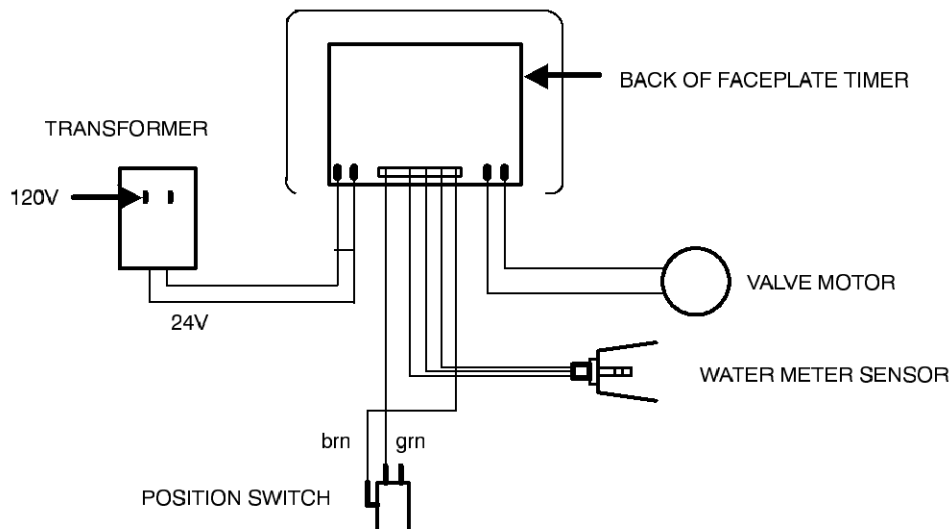

WATER FLOW THROUGH VALVE

SERVICE CYCLE

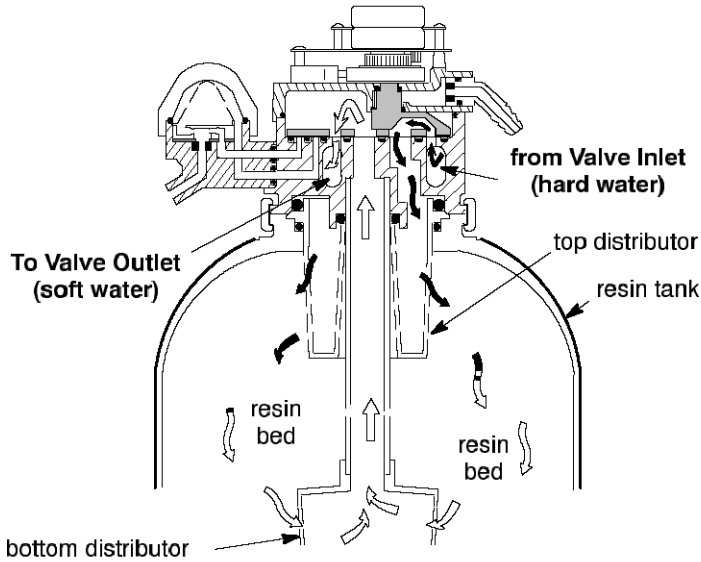

FILL CYCLE

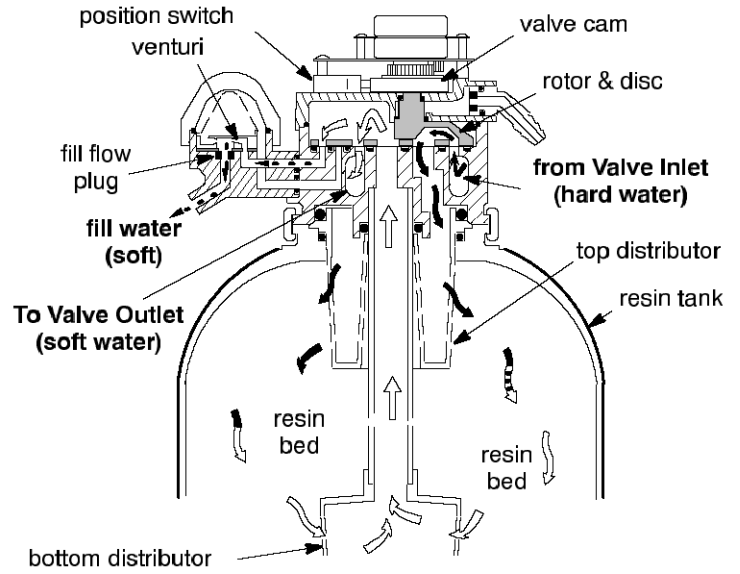

BRINING and BRINE RINSE CYCLES

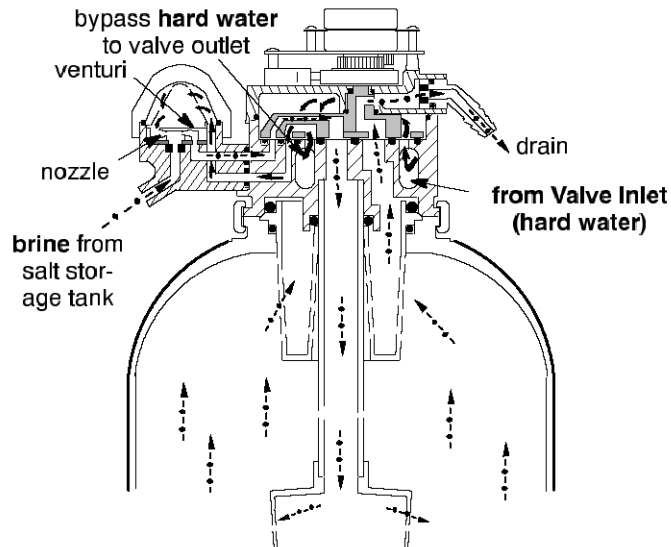

WATER FLOW THROUGH VALVE

BACKWASH CYCLE

FAST RINSE CYCLE

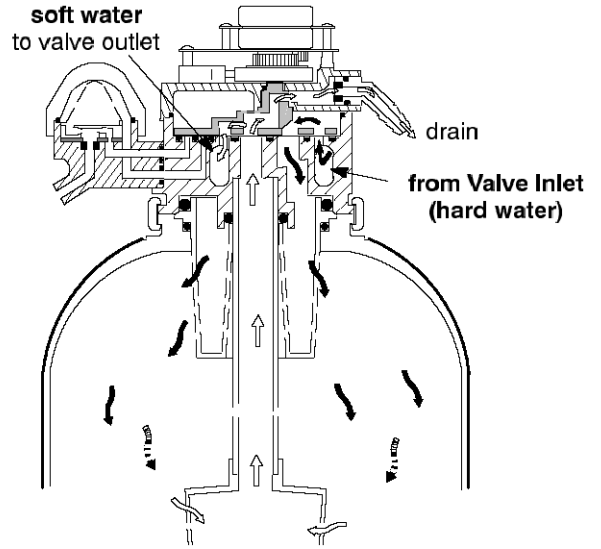
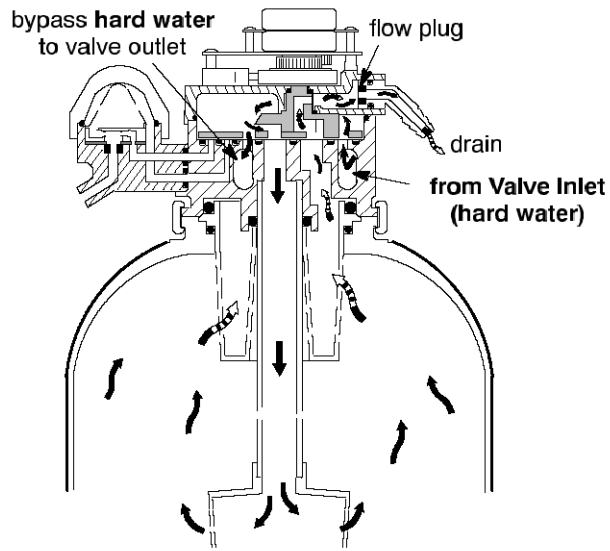

REPAIR PARTS

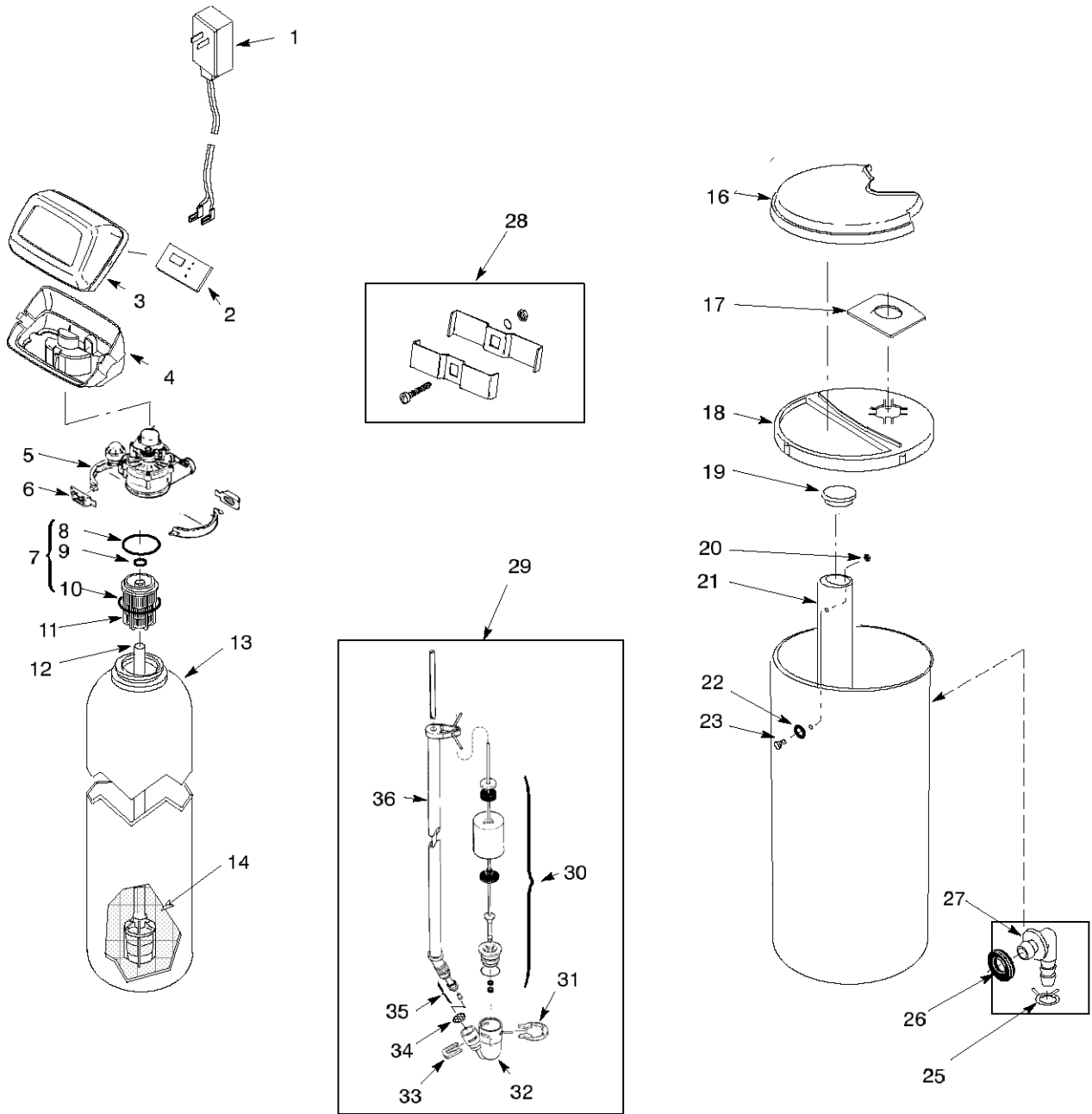

REPAIR PARTS

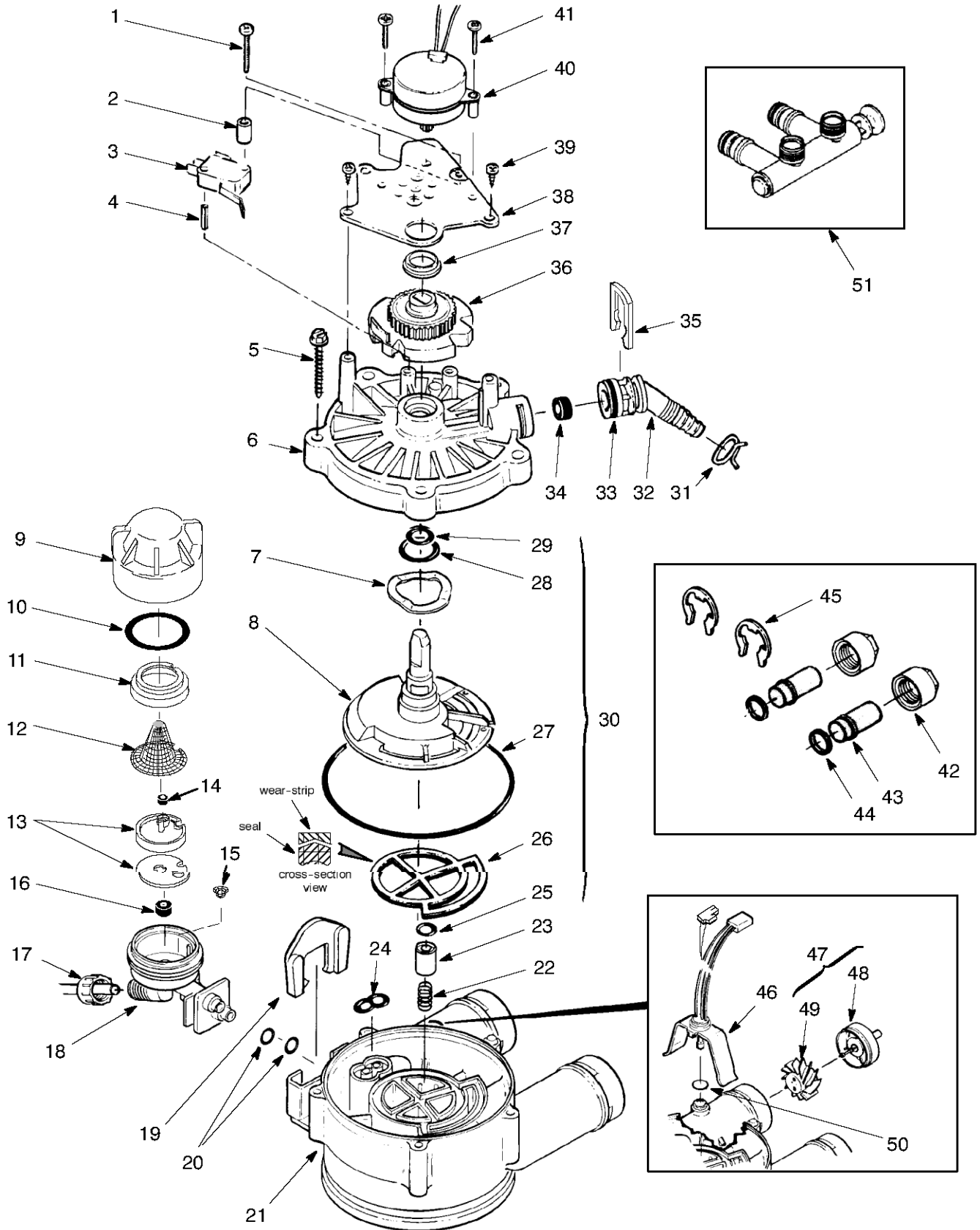



AUTOMATIC WATER SOFTENER

REPAIR PARTS

KEY NO.	PART NO.	DESCRIPTION OF PART	KEY NO.	PART NO.	DESCRIPTION OF PART
1	7070412	Screw, #4 – 24 x 1 – 1/8 in.	26	--	Rotor Seal
2	7117816	Spacer	27	--	O–ring Seal, 3–3/8 in. x 3–5/8 in.
3	7030713	Switch	28	--	O–ring Seal, 3/4 in. x 15/16 in.
4	7077472	Expansion Pin	29	--	O–ring Seal, 7/16 in. x 5/8 in.
5	7074123	Screw, #10 14 x 2 in. (5)	30	7129716	Seal Kit – Includes Key Nos. 24 – 29
6	7085263	Valve Cover	31	0900431	Hose Clamp
7	7082087	Wave Washer	32	7024160	Drain Hose Adaptor
8	7199232	Rotor & Disc	33	7170327	O–ring Seal, 5/8 in. x 13/16 in.
9	7199729	Cap	34	0501228	Flow Plug, Backwash / F. Rinse control
10	7170262	O–ring Seal, 1.1 in. x 1.4 in.	35	7142942	Clip
11	7167659	Screen Support	36	7113927	Cam and Gear
12	7146043	Screen	37	0503288	Bearing
13	7187772	Nozzle & Venturi w/Gasket Kit	38	7117808	Motor Plate
--	7204362	Gasket (only)	39	0900857	Screw, #6 – 20 x 3/8 in. (2)
14	0521829	Flow Plug, .1 gpm	40	7133008	Motor – Includes Key No. 41
15	7095030	Cone – Screen	41	7131755	Screw, #6 – 20 x 7/8 in. (2)
16	1148800	Fill Flow Plug, .3 gpm	42	0507369	Installation Nut (2)
17	1202600	Nut–Ferrule	43	0507615	Installation Tube (2)
18	7081104	Housing, Nozzle & Venturi	44	7170335	Washer (2)
--	7214969	Nozzle & Venturi Asm. (Incl. Key Nos. 9 – 16, and 18)	45	7116713	Clip (2)
19	7081201	Retainer	46	7248714	Sensor Housing/Wiring Harness Asm.
20	7170319	O–ring Seal, 1/4 in. x 3/8 in. (2)	47	7113040	Turbine and Support Asm.
21	7082053	Valve Body	48	--	Turbine Support
22	7129889	Spring	49	--	Turbine
23	7092642	Plug (Drain Seal)	50	0900060	O–ring Seal
24	--	Seal (Nozzle & Venturi)	51	7129871	Bypass Valve
25	--	O–ring Seal, 3/8 in. x 9/16 in.			



AUTOMATIC WATER SOFTENER

If you have a defective part or assembly under warranty, please fill in a parts return tag. Cut out the tag and include it with the defective part when you return it to the place where you purchased the softener. **To avoid destroying the repair parts information on the reverse side of this page, make a photocopy of the return tags to use.**

PARTS RETURN TAG			PARTS RETURN TAG		
CUSTOMER'S NAME			CUSTOMER'S NAME		
STREET ADDRESS			STREET ADDRESS		
CITY	STATE	ZIP CODE	CITY	STATE	ZIP CODE
CONDITIONER MODEL NUMBER	SERIAL NUMBER		CONDITIONER MODEL NUMBER	SERIAL NUMBER	
DATE PURCHASED	DATE PART FAILED		DATE PURCHASED	DATE PART FAILED	
5240 BRADCO BLVD MISSISSAUGA, ON L4W 1G7			5240 BRADCO BLVD MISSISSAUGA, ON L4W 1G7		

PARTS RETURN TAG			PARTS RETURN TAG		
CUSTOMER'S NAME			CUSTOMER'S NAME		
STREET ADDRESS			STREET ADDRESS		
CITY	STATE	ZIP CODE	CITY	STATE	ZIP CODE
CONDITIONER MODEL NUMBER	SERIAL NUMBER		CONDITIONER MODEL NUMBER	SERIAL NUMBER	
DATE PURCHASED	DATE PART FAILED		DATE PURCHASED	DATE PART FAILED	
5240 BRADCO BLVD MISSISSAUGA, ON L4W 1G7			5240 BRADCO BLVD MISSISSAUGA, ON L4W 1G7		