

*Experience
Change*

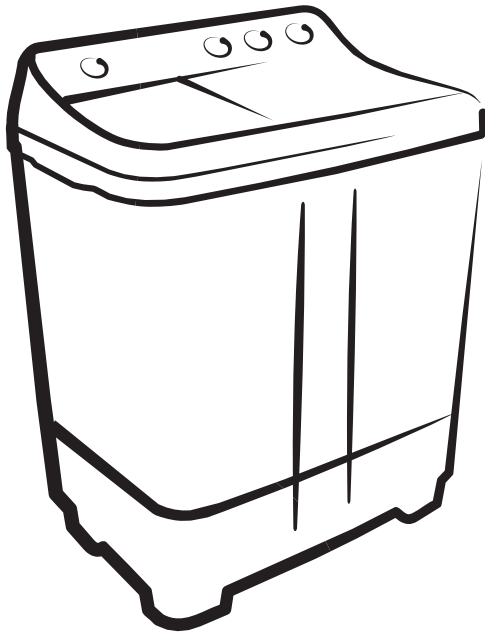

VIDEOCON

SERVICE MANUAL



MODEL:

SPRING-

WM VSP70LPW-SFK

WM VSP70PPW-SFK

WM VSP70EPW-SFK

WM VSP70APW-SFK

SAFETY PRECAUTION !

- DISASSEMBLE POWER CORD BEFORE SERVICING
- RECONNECT ALL GROUNDING DEVICES

IMPORTANT SAFETY NOTICE !

This service information is intended for individuals possessing adequate background of electrical, electronic and mechanical experience.

Any attempt to repair this appliance may result in personal injury or property damage.

The manufacturer or seller cannot be responsible for the interpretation of this information, nor can it assume any liability in connection with its use.

CONTENTS

1. SPECIFICATION	2
2. PRECAUTION	3
3. CAUTIONS FOR SAFETY	4
4. INSTALLATION INSTRUCTIONS	7
5. OPERATING INSTRUCTIONS	9
5-1 IDENTIFICATION OF PARTS	9
5-2 CONTROL PANEL INFORMATION	10
5-3 CARE AND MAINTENANCE	11
6. SERVICE INFORMATION	12
6-1 WIRING DIAGRAM	12
6-2 DISASSEMBLY INFORMATION	13
6-3 TROUBLESHOOTING	20
6-4 CHECK POINT AFTER REPAIR	22
7. EXPLODED VIEW	23
8. BILL OF MATERIAL	29

1. SPECIFICATIONS

MODEL :		Spring	
Power Supply		240V, 50 Hz AC	
Washing Capacity		7.0 Kg	
Water Level		Max. 60 Liters*	
		Min. 29 Liters	
Rated Power Consumption		Wash : 350 Watts	
		Spin : 180 Watts	
Spinning Drum speed		1350 ~ 1400 rpm	
Weight of the Machine		23 kg	
Machine Dimensions		Length 780 mm x Width 480 mm x Height 960 mm	
Washing Method		Roller Coaster Pulsator	
Cascade		No	
Wash Time		25Min. Soak + 15Min Wash	
Spin Time		05 Min.	
Ampere	NO LOAD	WASH	1.2 ~ 1.6
		SPIN	0.5 ~ 0.7
AC220V/50Hz	LOAD	WASH	1.4 ~ 2.0
		SPIN	0.7 ~ 1.3

As per Standard Testing Condition.

* Max. Water level at over flow level.

2. PRECAUTION

When performing troubleshooting and part replacement during servicing, note the following safety precautions:

1-1.Safety Precautions

1-1-1.Use Genuine Parts

The components of the washing machine have safety features such as non-combustibility and voltage withstanding. Therefore, always use the same part as suggested by the maker. In particular, be sure to use only design rated parts in case of major safety parts identified by the marker.

1-1-2.Grounding

Connect the grounding wire to the shell plate, and bury it under at least 25 cm of earth : alternatively, connect the ground wire to the appropriate pin on a properly grounded power receptacle. Never connect the wire to a telephone line, lightning rod, or gas pipe.

1-2.Servicing Precautions

1-2-1.Observe Warnings

Be sure to follow special warning and precautions that are described on part labels and in the owner's manual.

1-2-2.Parts Assembly and Wiring

Be sure to use insulation material (such as tube and tape). And be sure to restore all parts and wires to their original position. Take special care to avoid contact with sharp edges.

1-2-3.Perform Safety Checks after Servicing

After servicing, check to see that the screws, parts, and wiring are restored to their original positions, and check the insulation between the external metals and the socket plug. In addition, place the washing machine in a level position (less than 1 (one) degree) to prevent vibration and noise during operations.



1-2-4.Insulation Checks

Pull out the plug from the power receptacle, pour water into the spin tub, and then set the timer. Check to see that the resistance insulation between the terminals of the plug and the externally exposed metal is greater than 1M Ohm .









Note :When it is impossible to perform insulation check with a 500V insulation resistance tester, use other testers for inspection.

3. CAUTIONS FOR SAFETY



- Please observe the following notes for safety.
- The symbols indicate as follows.

Symbol	Meaning
 WARNING	Indicates possibility of death or serious injury of a repair technician and a person near by through them is conducted work, or of a user by a defect of the product after the work performed by the technician.
 CAUTION	Indicates possibility of injury or physical damages* of are pair technician and a person nearby through the misconducted work,or of a user by a defect of the product after the work performed by the technician.

*Means secondary damages of property, furniture, domestic animal and pet.

Graphic Symbol	Meaning
 ELECTRIC SHOCK	1. indicates a caution(including a warning). Specific instruction is followed by a graphic or characters in or near  . Symbol left warns an electric shock.
 DO NOT DISASSEMBLE	 indicates prohibition (act must not be conducted). Specific instruction is followedby a graphic or characters in or near  . Symbol left warns not to disassemble.
 UNPLUG	 indicates forcing (act must be conducted). Specific instruction is followed by a graphic or characters in or near  . Symbol left warns to unplug the power cord.











WARNING

 OUTOFCHILD	<ul style="list-style-type: none"> ■ Advise the customer to keep children out of the work place. Children may be injured with a tool or a disassembled part.
 UNPLUGPOWER	<ul style="list-style-type: none"> ■ Unplug power cord for the work such as disassembling which is not unnecessary to power on .Do not hold the plug by awethand. Failing to unplug may cause an electric shock.
 USE REPAIR PARTS	<ul style="list-style-type: none"> ■ Use the specified repair parts when repairing the product. Otherwise, a malfunction may occur. Also,a short circuit, ignition or other danger to the customer may occur.

3. CAUTIONS FOR SAFETY







WARNING

 CHECK INSULATION RESISTANCE	<ul style="list-style-type: none"> After repair, measure insulation resistance between the charging part (power cord plug) and the non-charging metallic part (ground) with an insulation resistance meter(500V).The resistance shall be 10M Ohm or more. Failing to check the insulation resistance may cause a short circuit, electric shock or other diseases to the customer.
 DO NOT MODIFY	<ul style="list-style-type: none"> Do not modify the product. An electric shock or ignition may occur.
 DO NOT DISASSEMBLE AND REPAIR	<ul style="list-style-type: none"> Only are pair technician can disassemble and repair. An electric shock, ignition or malfunction may cause injury.
 USE EXCLUSIVE SOCKET	<ul style="list-style-type: none"> Use an exclusive 220VAC/15A socket for the washing machine. Otherwise, an electric shock or ignition may cause. Sharing the same socket with other instrument causes heating of a branch socket and result in a fire.
 CONNECT GROUNDING WIRE	<ul style="list-style-type: none"> Connect the grounding wire. Failing to do so may cause an electric shock when a short circuit occurs. Consult an electric workshop or a sales shop.
 DO NOT USE WET PLACE	<ul style="list-style-type: none"> Do not install in a bathroom or a place exposed to wind or rain. An electric shock or a short circuit may cause a fire.
 DO NOT SPLASH WATER	<ul style="list-style-type: none"> Do not pour or immerse electrical parts into water or liquid solution. An electric shock or ignition may occur.
 REMOVE DUST	<ul style="list-style-type: none"> Wipe off dust adhered to the plug of power cord. Dust may cause a fire.
 AVOID INFLAMMABLE	<ul style="list-style-type: none"> Do not put inflammable into the washing tub. Do not put cloths stained with kerosene, gasoline, benzene, thinner, alcohol, etc. It may cause a fire or explosion.
 DO NOT TOUCH	<ul style="list-style-type: none"> Do not touch the laundry before the spin basket stops completely. The laundry entangles your hand causing an injury even if the basket rotates slowly. Pay special attention to children.

3.CAUTIONS FOR SAFETY



CAUTION

 <p>INSTALL CAREFULLY</p>	<ul style="list-style-type: none">■ Ask an service engineer to install the product. Install the product securely and safely according to the electrical equipment technical standard and the wiring standard. Incorrect work causes an electric shock and a fire.
 <p>DO NOT PULL</p>	<ul style="list-style-type: none">■ Do not pull the power cord when unplugging. Hold the power plug to unplug. An electric shock or short circuit may cause a fire.
 <p>DANGER HAND</p>	<ul style="list-style-type: none">■ Do not insert your hand under the washing machine during operation. There is a rotary part under the machine which may cause an injury.
 <p>WATER LEAKAGE</p>	<ul style="list-style-type: none">■ Before starting washing, open the faucet and check water supply hose joint which shall not be loosened for no water leaks. The loose screw or hose joint may cause water leakage resulting in an unexpected damage.

4. INSTALLATION INSTRUCTION

4-1. Installation

4-1. Level Specifications and Wall-Clearance Distances

- 1) Instal the washing machine on a solid and level floor.
- 2) Place menton an inclined, weak or rough floor may cause abnormal noise or trembling.
- 3) Place the machine at least 15cm away from the wall.

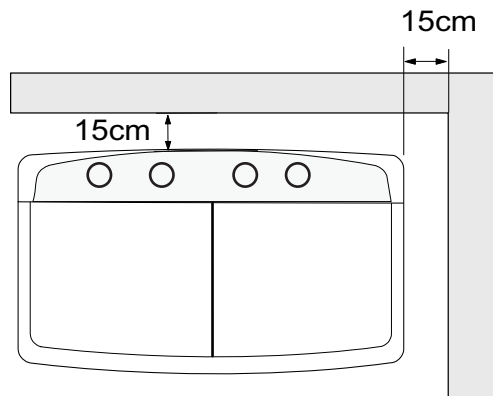

4-2. Install the Washing Machine in well ventilated area.

Machine and Power socket should be covered from top to avoid rain, sunlight or water on machine.

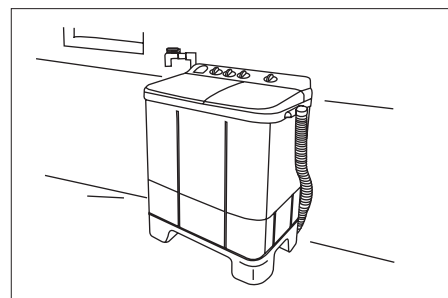

4-3. Insert the Power plug firmly into the main power supply.



4-4. Connect the Water supply hose to Tap and Inlet pipe in Panel.

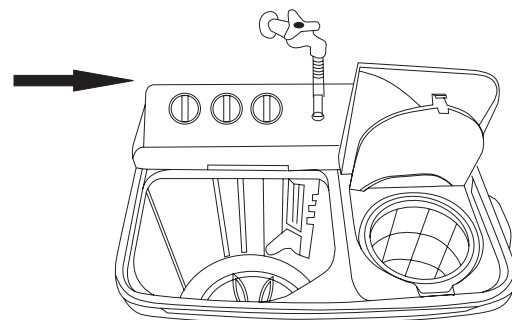

4. INSTALLATION INSTRUCTION

4-5. Positioning the Drain Hose

1) When there is no threshold, the length of the drain hose should not exceed 3m.

2) When it is necessary to connect the drain hose with the drain outlet far away, connect the extension hose and applicable parts available from dealers or service centers.

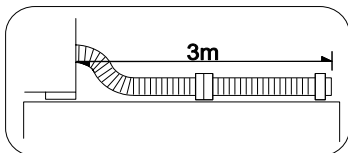

3) Do not install the drain hose where it must exceed over a threshold of 3 cm or more; do not install where there is a threshold and the hose must exceed for more than 2m.

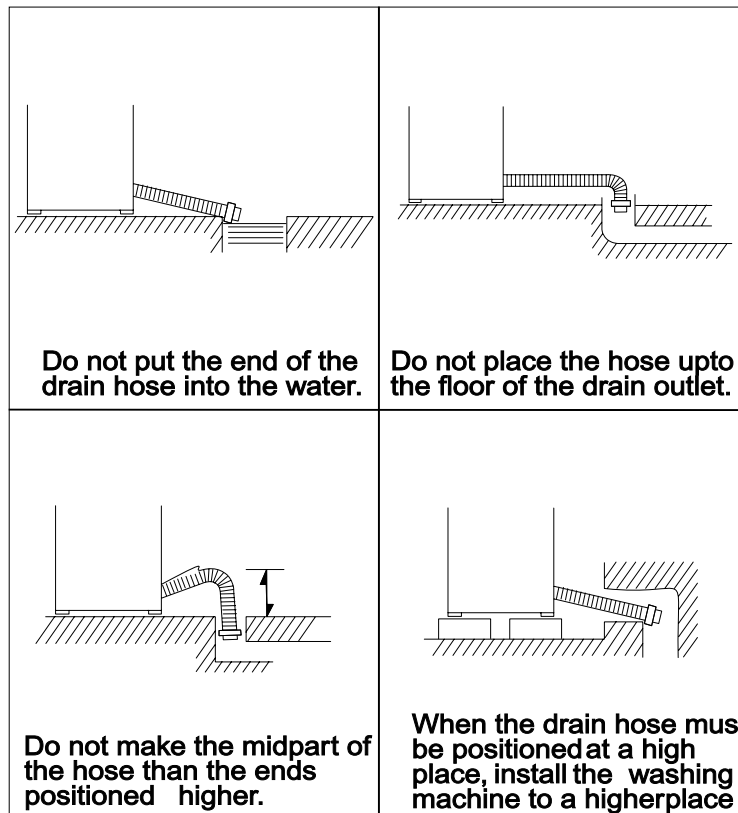
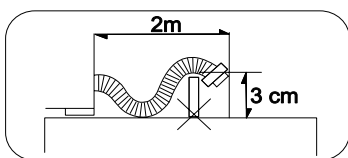

4-6. Grounding

1) Upon installing grounding, make sure if power socket is out of power outlet.

2) Grounding should be connected to either metal water supply pipe or copper grounding pole deeper than 25cm in the damp ground.(Fig1)

3) If water pipe is a plastic, no protection is obtained from a possible electric shock.

4) If the power outlet is available with grounding connection, grounding in the washing machine should be firmly connected to the connection of the outlet.(Fig2)

5) You should not connect, the grounding to the gas-pipe because it will cause an explosion. (Fig3)

6) If the grounding is connected to either telecommunication line or lightning-arrest line, an extreme hazard is caused therefore, no connection should be made to such lines.(Fig4)

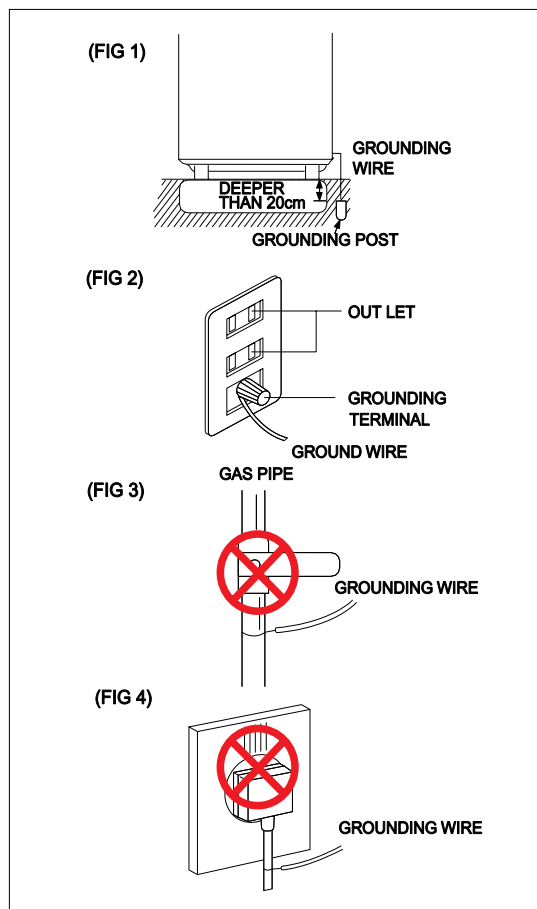

5. OPERATING INSTRUCTION

5-1. IDENTIFICATION OF PARTS

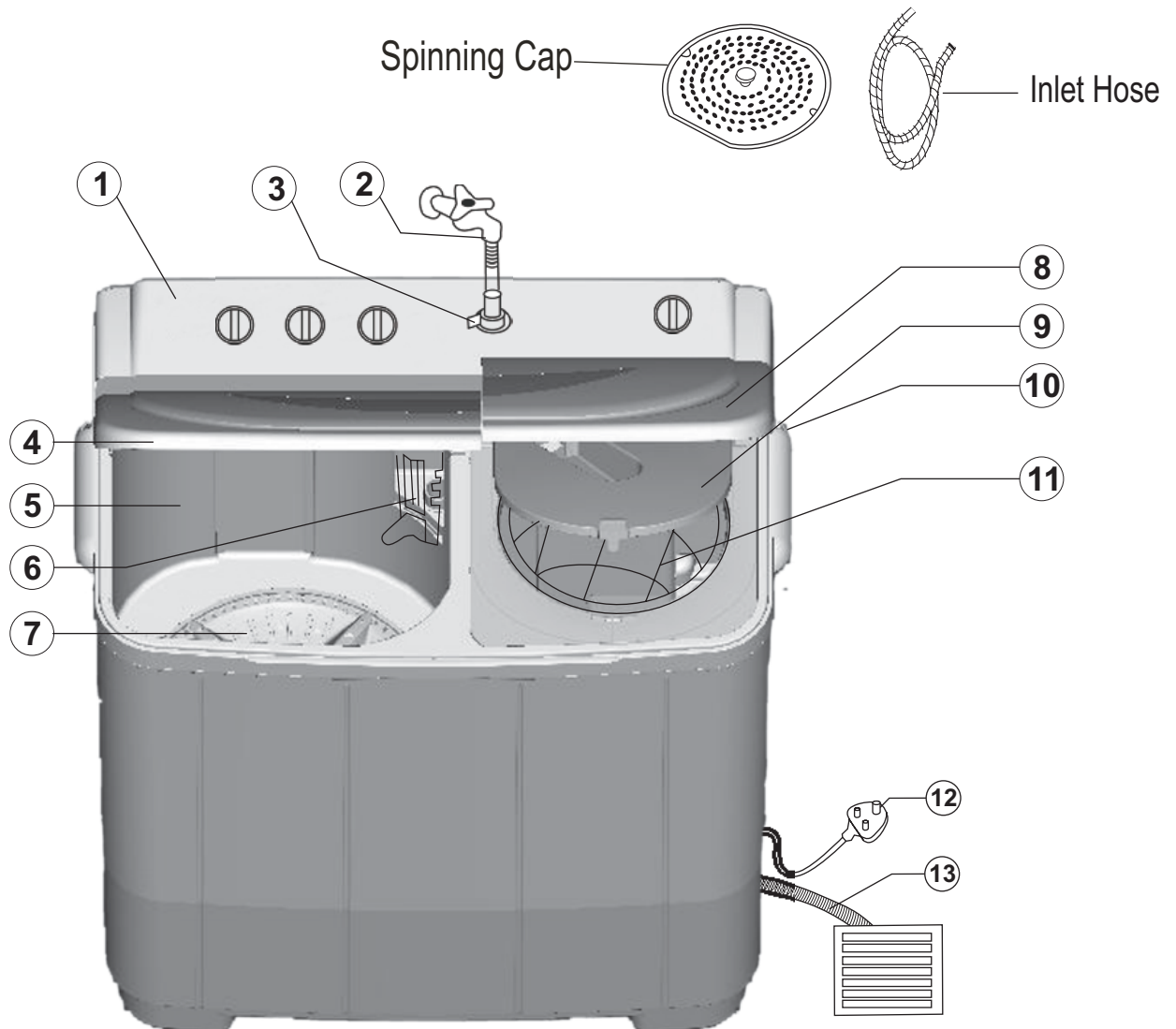

1. Control Panel of Machine
2. Water Inlet
3. Water Supply Selector
4. Wash Tub Lid
5. Wash Tub
6. Overflow Filter
7. PUCH+3 Pulsator

8. Spinner Lid
9. Inner Lid
10. Drain Hose Hanger
11. Spinner Tub
12. Power cord
13. Drain Hose

(Please do not match this figure with your machine as it may be different from your model. These are schematic diagrams only).

5. OPERATING INSTRUCTION

5-2. CONTROL PANEL INFORMATION

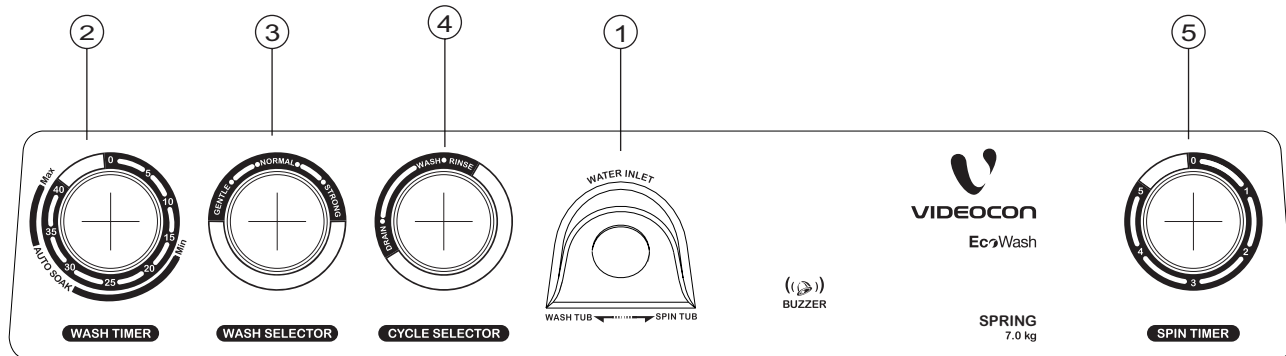

1. Water Inlet : This is used to direct water supply to wash tub for washing or spin tub for spin shower.
2. Wash Timer : This timer is used for Auto SOAK, WASH and RINSE operations.
Following combination can be selected.
 - A) Auto Soak + Wash :- Select the desire soak time by setting the Timer between 15 ~ 40 min.,
 - B) Wash/Rinse :- You can select any Wash/Rinse time up to 15min. if you want Wash/Rinse time for shorter duration turn the knob up to 10min. position and then turn it back to desired position.
3. Wash Selector : Set the knob to 'STRONG', 'GENTLE', 'NORMAL' according to kinds and quantity of the laundry.
4. Cycle Selector : This selector is to set for "WASH/RINSE" or "DRAIN" the water from wash tub.
 - WASH / RINSE for wash & rinse program.
 - DRAIN for draining the water from the wash tub.
5. Spin Timer : This timer is used to select your desired length of time to spin laundry by using 5 minutes timer. (if you want to set the timer to 2 min. or less, turn the selector up to the 5 min. position, and then turn it back to the desired position.

Note : Do not rotate the knobs more then prescribed limits.

5. OPERATING INSTRUCTION

5-3. CARE AND MAINTENANCE

BE SURE TO REMOVE THE POWER PLUG FROM MAIN POWER SUPPLY BEFORE CLEANING THE MACHINE.

How to clean the Lint Filter

1. Pull out the lint filter from the lock, use fingers to press and pull out at the part of the lint filter's side

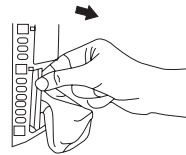

2. Rinse the dirt from filter with clean water.

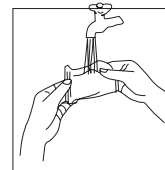

3. Set back to the original position. Insert the bottom first as shown, press filter down and lock the upper lock as shown.

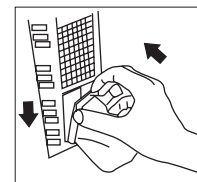

Cleaning the Wash Tub

1. After washing is complete, fill fresh water above the level of Pulsator, without adding clothes.
2. Run the machine for 1 ~ 2 minutes and then turn the Cycle Selector knob to "DRAIN" position when Pulsator is still rotating.
3. When water is completely drained out, turn the Cycle Selector knob to "WASH/RINSE" position.
4. Finally turn OFF the machine.

6. SERVICE INFORMATION

6-1. WIRING DIAGRAM



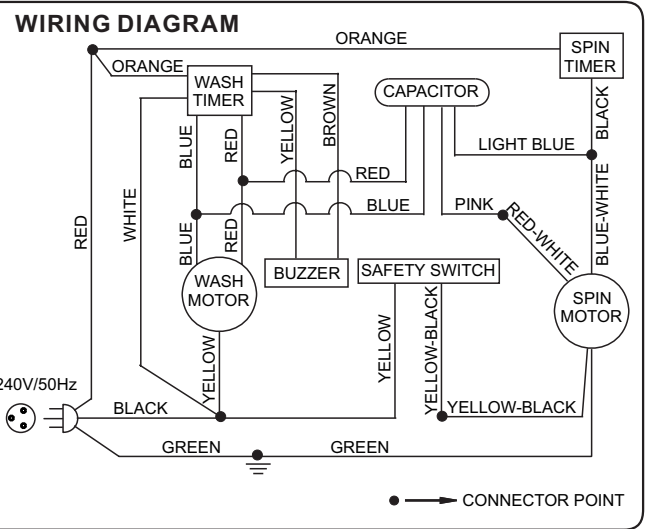

MODEL SERIES		MARINE PLUS MARINE DLX PLUS	SPRING	KSA-682 P LS-682S
CAPACITY	WASH	7.0 kg	7.0 kg	6.8 kg
	SPIN	3.2 kg	3.2 kg	3.2 kg
WATER LEVEL	Max.	60 Ltr.	60 Ltr.	60 Ltr.
	Min.	29 Ltr.	29 Ltr.	29 Ltr.
SUPPLY		240V, 50Hz AC		
INPUT POWER		WASH : 350 W, SPIN : 180 W		
SIZE IN mm		L780xW480xH960		
NET WEIGHT		23.0 kg 		

Marketed by : VIDEOCON INDUSTRIES LIMITED
 14th KMS STONE, AURANGABAD - PAITHAN ROAD,
 CHITEGAON, AURANGABAD - 431 105.
 MAHARASHTRA, INDIA



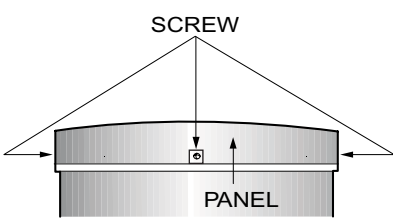
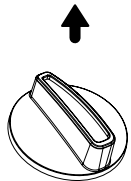
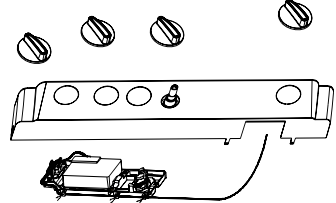
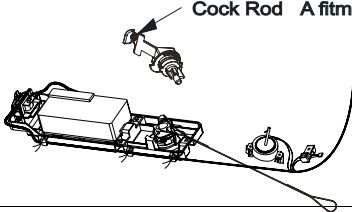
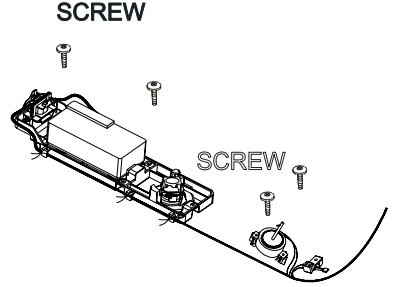

6. SERVICE INFORMATION

6-2. DISASSEMBLY INFORMATION

ITEM	HOW TO DISASSEMBLE AND ASSEMBLE	DIAGRAM						
<p>WASH TIMER AND SPIN TIMER</p>	<p>1) Disassembly of the WASH TIMER.</p> <ol style="list-style-type: none"> Using screw driver unscrew the screws from the Panel and Tub. (Fig 1) Disassemble Knob assembled to the WASH TIMER & SPIN TIMER, WASH SELECT OR AND CYCLE SELECTOR. (Fig. 2) <p>CAUTION :Please do not apply an excessive force.</p> <ol style="list-style-type: none"> Lift up Panel while Pulling to theFront. (Fig 3) Remove the Timer plate asm from Panel by unscrewing the screws from Panel and Timer plate. Disassemble the COCK ROD - A that is connected to the LEVER- A DRAIN. (Fig4) Disassemble the Wash Timer and Spin Timer by removing the screw fitted to Body(Fig 5) 	<p>(Fig 1)</p>  <p>(Fig 2)</p>  <p>(Fig 3)</p>  <p>(Fig 4)</p>  <p>(Fig 5)</p> 						
<table border="1" style="width: 100%;"> <tr> <td colspan="2" style="text-align: center;">⚠ WARNING</td> </tr> <tr> <td style="text-align: center;"></td> <td> <p>Unplug the power cord for the work unnecessary to power on like disassembling. Do not hold the plug by a wet hand. Failing to unplug may cause an electric shock.</p> </td> </tr> <tr> <td colspan="2" style="text-align: center;">UNPLUG POWER</td> </tr> </table>		⚠ WARNING			<p>Unplug the power cord for the work unnecessary to power on like disassembling. Do not hold the plug by a wet hand. Failing to unplug may cause an electric shock.</p>	UNPLUG POWER		
⚠ WARNING								
	<p>Unplug the power cord for the work unnecessary to power on like disassembling. Do not hold the plug by a wet hand. Failing to unplug may cause an electric shock.</p>							
UNPLUG POWER								

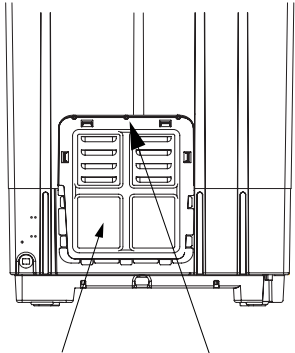
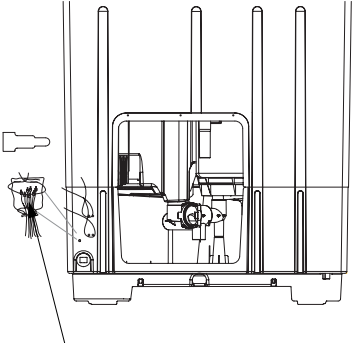

6. SERVICE INFORMATION

6-2. DISASSEMBLY INFORMATION

Item	How to Disassemble and Assemble	Drawings
<p>BACK COVER</p>	<p>1. Untighten the screws from BACK COVER and TUB, and disassemble it by removing the Snap Locks. (Fig 1)</p>	<p>(Fig 1)</p>  <p>COVER-BACK SCREW</p>
	<p>2. Remove a plastic bag on Connector part, and cut off all wire. (Fig 2)</p>	<p>(Fig 2)</p>  <p>PLASTIC BAG</p>
	<div style="border: 1px solid black; padding: 10px; text-align: center;">  <p>WARNING</p> </div> <div style="display: flex; align-items: center; justify-content: center;"> <div style="text-align: center; margin-right: 20px;">  <p>UNPLUG POWER</p> </div> <div> <p>Unplug the power cord for the work unnecessary to power on like disassembling. Do not hold the plug by a wet hand. Failing to unplug may cause an electric shock.</p> </div> </div>	



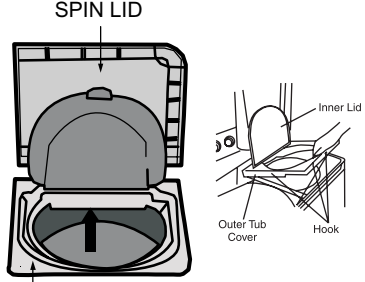
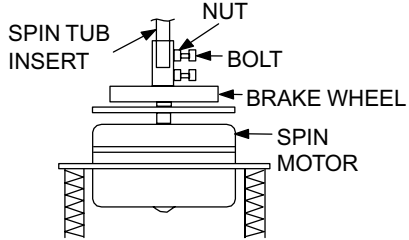
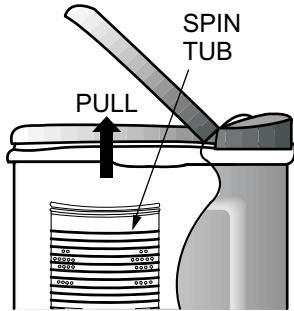



6. SERVICE INFORMATION

6-2. DISASSEMBLY INFORMATION

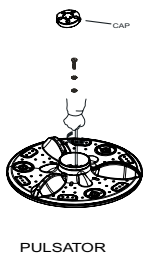
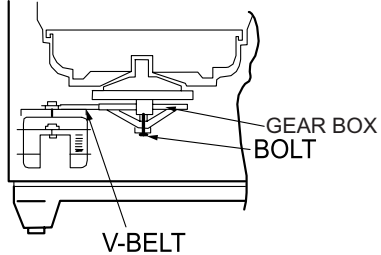
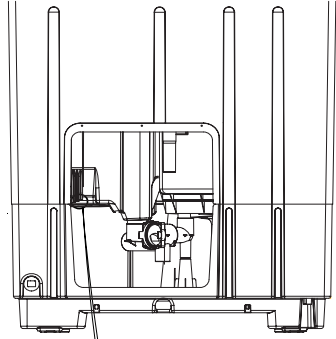
Item	How to Disassemble and Assemble	Drawings
<p>BASKET-SPINNING</p>	<p>1. OUTER TUB COVER is fitted to BODY B with snap locks. To remove OUTER TUB COVER, hold it tightly from center and PULL upwards. Snap locks will disengage from the BODY B. (Fig. 1)</p>	<p>(Fig 1)</p> 
	<p>2. Untighten a nut assembled to the BRAKE WHEEL, and turn a bolt to counterclockwise and remove it. (Fig. 2) (Used tool boxdriver)</p>	<p>(Fig 2)</p> 
	<p>3. Lift the SPIN BASKET to upward and remove it, from BRAKE WHEEL. (Fig 3)</p> <p>CAUTION: Beware not to loose the WATER-CUTTER because it will slide out from SHAFT-when BASKET-SPINNING is removed.</p> <p>Besure to followings after replacing the SPIN BASKET. Screw properly the bolt which holds BRAKE WHEEL to SPIN BASKET, otherwise, too high fastening may cause breaking the bolt. After screw the bolt, you must tighten the nut for secure fixing.</p>	<p>(Fig. 3)</p> 
	<div style="border: 1px solid black; padding: 5px;"> <p style="text-align: center;">WARNING</p> <div style="display: flex; align-items: center;">  <div style="margin-left: 10px;"> <p>Unplug the power cord for the work unnecessary to power on like disassembling. Do not hold the plug by a wet hand Failing to unplug may cause an electric shock.</p> </div> </div> <p style="text-align: center;">UNPLUG POWER</p> </div>	

6. SERVICE INFORMATION

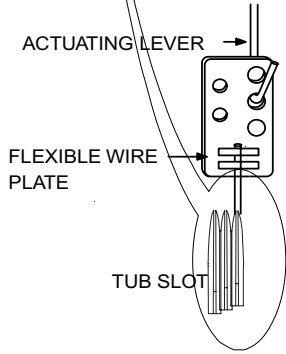
6-2. DISASSEMBLY INFORMATION

ITEM	HOW TO DISASSEMBLE AND ASSEMBLE	DRAWINGS				
PULSATOR	<ol style="list-style-type: none"> 1. Remove the Cap from Pulsator assy, Using “-ve” Screw Driver (Fig.1) 2. Unscrew the Pulsator Assy, Using ‘+ve’ Screw Driver. (Fig. 1) 	<p>(Fig 1)</p>  <p>PULSATOR</p>				
V-BELT	<ol style="list-style-type: none"> 3. Remove V BELT from Gear Box Motor Pulley (Fig. 2) 	<p>(Fig 2)</p>  <p>GEAR BOX BOLT</p> <p>V-BELT</p>				
FLEXIBLE WIRE	<ol style="list-style-type: none"> 4. Keeping the SPIN LID at open position, remove the ACTUATING LEVER form the FLEXIBLE WIRE PLATE (Fig 3) 5. Remove flexible wire plate from tub slot. 	<p>(Fig 3)</p> 				
<table border="1" style="width: 100%; border-collapse: collapse;"> <tr> <td colspan="2" style="text-align: center;"> CAUTION</td> </tr> <tr> <td style="text-align: center;"></td> <td> <p>WATERLEAKAGE</p> <p>Before starting washing, open the faucet and check that the water supply hose joint is not loose and no water leaks. The loose screw or hose joint may cause water leakage resulting in an unexpected damage</p> </td> </tr> </table>		 CAUTION			<p>WATERLEAKAGE</p> <p>Before starting washing, open the faucet and check that the water supply hose joint is not loose and no water leaks. The loose screw or hose joint may cause water leakage resulting in an unexpected damage</p>	 <p>ACTUATING LEVER</p> <p>FLEXIBLE WIRE PLATE</p> <p>TUB SLOT</p>
 CAUTION						
	<p>WATERLEAKAGE</p> <p>Before starting washing, open the faucet and check that the water supply hose joint is not loose and no water leaks. The loose screw or hose joint may cause water leakage resulting in an unexpected damage</p>					

6. SERVICE INFORMATION

6-2. DISASSEMBLY INFORMATION

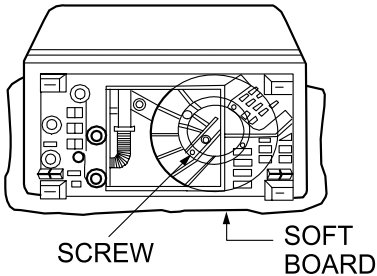
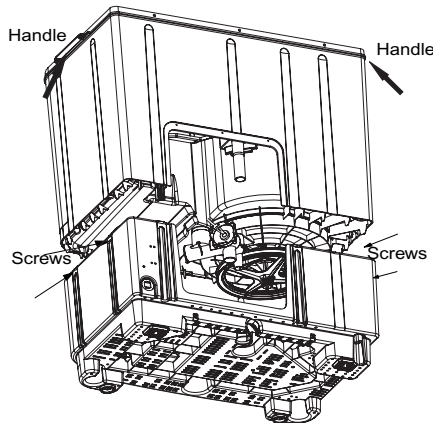
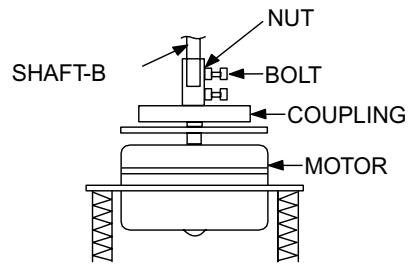
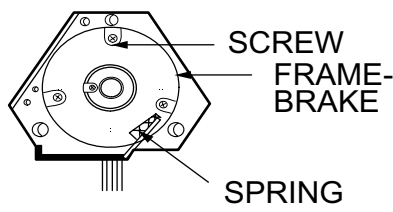
ITEM	HOW TO DISASSEMBLE AND ASSEMBLE	DRAWINGS
<p>ASS'Y-GEAR BOX</p> <p>SPIN MOTOR and WASH MOTOR</p>	<p>6. Lay down the machine of soft board placed on floor, to avoid scratch or damage on machine. (Fig. 5)</p>	<p>(Fig 5)</p>  <p>Diagram showing the top cover of the machine with a screw and a soft board. Labels: SCREW, SOFT BOARD.</p>
	<p>7. Unscrew the screws from Base and Tub for all four sides. (Fig. 6)</p> <p>8. Lift the Tub upside holding from Handles and separate Tub from Base (Fig. 6)</p>	<p>(Fig 6)</p>  <p>Diagram showing the tub being lifted from the base using handles and screws. Labels: Handle, Handle, Screws, Screws.</p>
	<p>9. Untighten a nut assembled to the BRAKE WHEEL, and turn a bolt to counterclockwise and remove it. (Fig. 7) (Used tool boxdriver)</p>	<p>(Fig 7)</p>  <p>Diagram showing the brake wheel assembly with labels: NUT, BOLT, COUPLING, MOTOR, SHAFT-B.</p>
	<p>10. Using driver, disassemble three Brake frame screws. (Fig 8)</p>	<p>(Fig 8)</p>  <p>Diagram showing the brake frame with labels: SCREW FRAME-BRAKE, SPRING.</p>

6. SERVICE INFORMATION

6-2. DISASSEMBLY INFORMATION

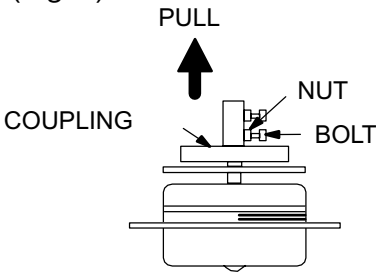
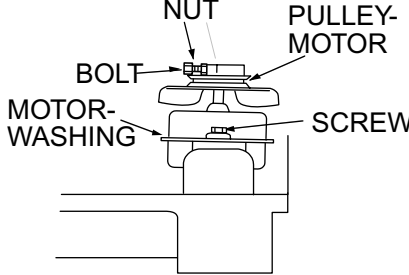
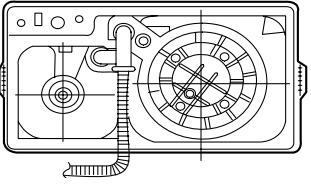
ITEM	HOW TO DISASSEMBLE AND ASSEMBLE	DRAWINGS
<p>ASS'Y-GEAR BOX</p> <p>SPIN MOTOR and WASH MOTOR</p>	<p>11. Untighten Brake Asm Nut and Bolt. Pull the Brake Asm upside and remove it from Spin Motor shaft. Remove the Brake Frame.(Fig9)</p> <p>12. Lift the Spin Motor from Base.</p>	<p>(Fig 9)</p> 
	<p>11) Disassembly of WASH MOTOR.</p> <p>1. Unscrew the Motor Pulley Nut and Bolt. Lift the Motor Pulley from the Wash Motor Shaft</p> <p>2. Unscrew three set screws assembled to the Wash Motor and Base.(Fig 10)</p> <p>3. Lift the Wash Motor from Base.(Fig. 10)</p>	<p>(Fig 10)</p> 
	<p>12. Separate the Gear Box asm by unscrewing the screw from Gear Box asm and Tub.</p> <p>Move Gear Box asm two or three times right left hand and remove it out.</p>	<p>(Fig 11)</p> 
	<p>Caution in Assembling.</p> <p>When assembly, be aware not to make error in setting the position of gear box to an original position and set-screws.</p>	

6. SERVICE INFORMATION

6-2. DISASSEMBLY INFORMATION

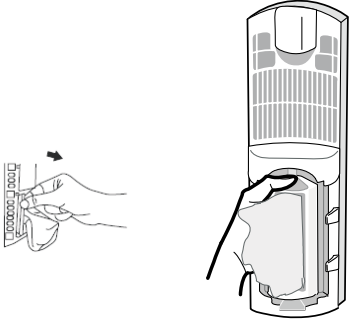
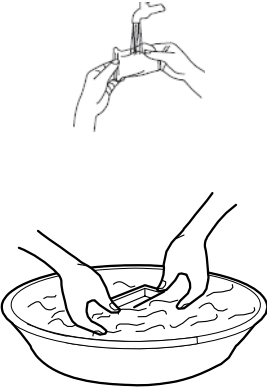
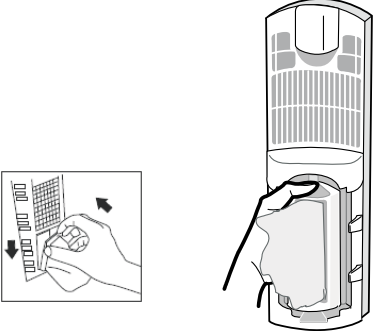
ITEM	HOW TO DISASSEMBLE AND ASSEMBLE	DRAWINGS
FILTER UNIT ASSEMBLY	1. Pull out the filter unit from over flow filter lock, use use fingers to press and pull out (Fig 1)	<p>(Fig 1)</p>  <p>Over Flow Filter with Filter Unit</p>
	2. Turn lint filter inside out, and rinse the dirt from filter. (Fig 2)	<p>(Fig 2)</p> 
	3. Set back to the original position, inset the bottom first as shown press down and lock as the arrow (Fig 3)	<p>(Fig 3)</p> 

6. SERVICE INFORMATION

6-3. TROUBLE SHOOTING

TYPICAL FAILURE		POSSIBLE CAUSE	REPAIR
Wash Rinse	No agitation or poor agitation	Power plug is not connected properly	Insert power plug correctly
		Defective Motor Defective Timer Defective Gear-Box	Replace
		Clothes or objects bit in pulsator gap	Remove pulsator and check. Remove objects
		Defective mounting of pulsator screw	Fixing pulsator
		Belt loose	Adjust the belt tention
		Too large amout of wash load	Take out some clothes
	Excessive noise during agitation	Coin or button between pulsator and tub	Remove objects
		Defective Bearing Case	Replace Bearing Case
		Defective fixing of pulley or transformed	Adjust pulley or replace it
	Drain	No Drain	Drain Hose is not lowered
Lints accumulated in Drain Hose			Clean or replace Hose
Drainning does not stop		Cock Rod A is broken or seperated	Replace or connet
		Defective DV Bellow	Adjust or replace
		D.V-Spring is broken away or elesticity is insufficient	Adjust or replace D.V-spring
		Guide-A.T is derailed or defective Guide-A.T	Adjust or replace
Spin	No spinning	Lid is open	Close the lid adn advise customer
		Out of adjustment of Safety Switch or defective Safety Switch.	Adjust fixing positon of Safety Switch or replace Safety Switch
		Defective Spin imer	Replace
		Brake wire is broken.	Replace B r a k e w i r e

6. SERVICE INFORMATION

6-3. TROUBLE SHOOTING

TYPICAL FAILURE		POSSIBLE CAUSE	REPAIR
Spinning basket does not stop	Brake shoe is worn off or broken	Replace brake shoe	
	Brake arm does not move	Replace brake frame	
	Brake spring is broken away or elasticity is insufficient	Replace brake Spring	
Excessive noise during spin	Machine is not level. Weak floor.	Level the machine. Install on a horizontal and stable floor	
	Screw for fixing motor come loose.	Fix screw	
	Clothes breake into the gap between Tub and Basket	Remove clothes	

6. SERVICE INFORMATION

6-4. CHECK POINT AFTER REPAIR

After repairing, be sure to make the following trial operation to see if the washer operates normally.

CheckPoint	Inspection & Judgement						
1) Insulation resistance	<p>Unplug the cord from the power outlet and turn on all the timers. Then measure the insulation resistance between the plug (both of 2 pins) and grounding wire of the machine.</p> <p>The measured value should be more than 1MΩ. In the following case, check sufficiently.</p> <ol style="list-style-type: none"> 1) Replace the electrical parts with new ones. 2) Used in a moist place. 3) Used more than 5 years. 						
2) Safety device	<p>Check the full stop time of the spin basket. Braking time should be as follows.</p> <table border="1" data-bbox="521 888 1484 1010"> <thead> <tr> <th data-bbox="521 888 886 932">Load</th> <th data-bbox="886 888 1484 932">Normal stop time</th> </tr> </thead> <tbody> <tr> <td data-bbox="521 932 886 976">No load</td> <td data-bbox="886 932 1484 976">Within 7 sec.</td> </tr> <tr> <td data-bbox="521 976 886 1010">Rated load</td> <td data-bbox="886 976 1484 1010">Within 10 sec.</td> </tr> </tbody> </table>	Load	Normal stop time	No load	Within 7 sec.	Rated load	Within 10 sec.
Load	Normal stop time						
No load	Within 7 sec.						
Rated load	Within 10 sec.						
3) Safety designated parts	<p>Replace with the designated parts in the case the used parts are not proper. (Refer to "*" marked parts in the parts list)</p>						
4) Wiring	<p>Check to see if the lead wire is properly connected without looseness or overtension and taping and setting are firmly performed.</p>						
5) Screws and Nuts	<p>Check to see if the screws, nuts, etc are firmly tightened and the screw locks are applied.</p>						
6) Removal of useless matter	<p>Check to see if useless matters (Screws, bits of wire, etc) are left inside the machine.</p>						
7) Leakage of oil and water	<p>Check to see if oil or water leaks out around the spinning, gear box, motors and connection of the v-case.</p>						
8) Power-cord	<p>Check to see if the cord, the plug, the outlet etc, are not damaged. Do not use table tape with multi-wiring.</p>						
9) Level Installation	<p>Check to see if the machine is installed horizontally.</p>						

7. EXPLODED VIEW

7-1. PANEL ASSEMBLY

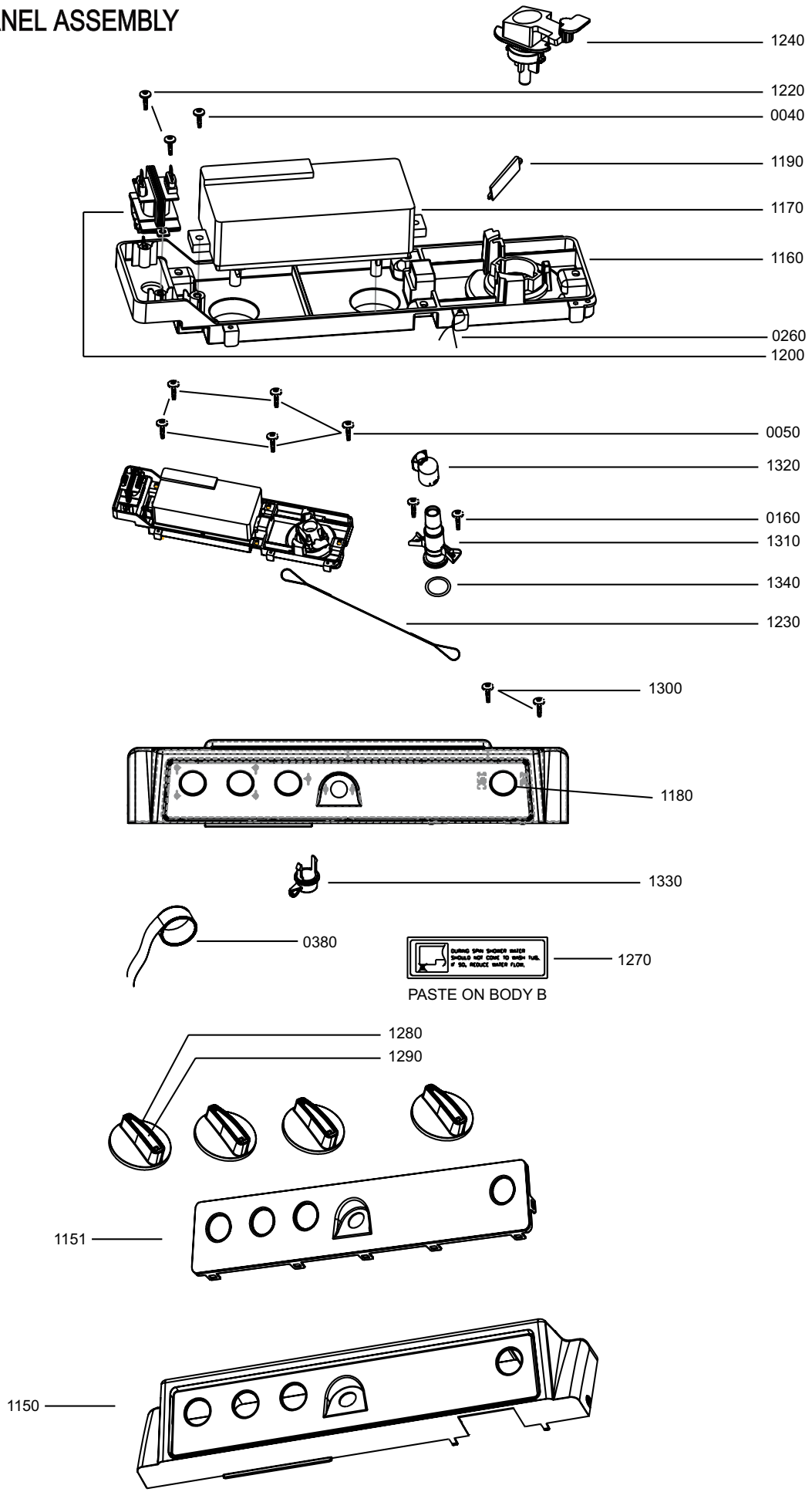

7. EXPLODED VIEW

7-2. BODY - B ASSEMBLY

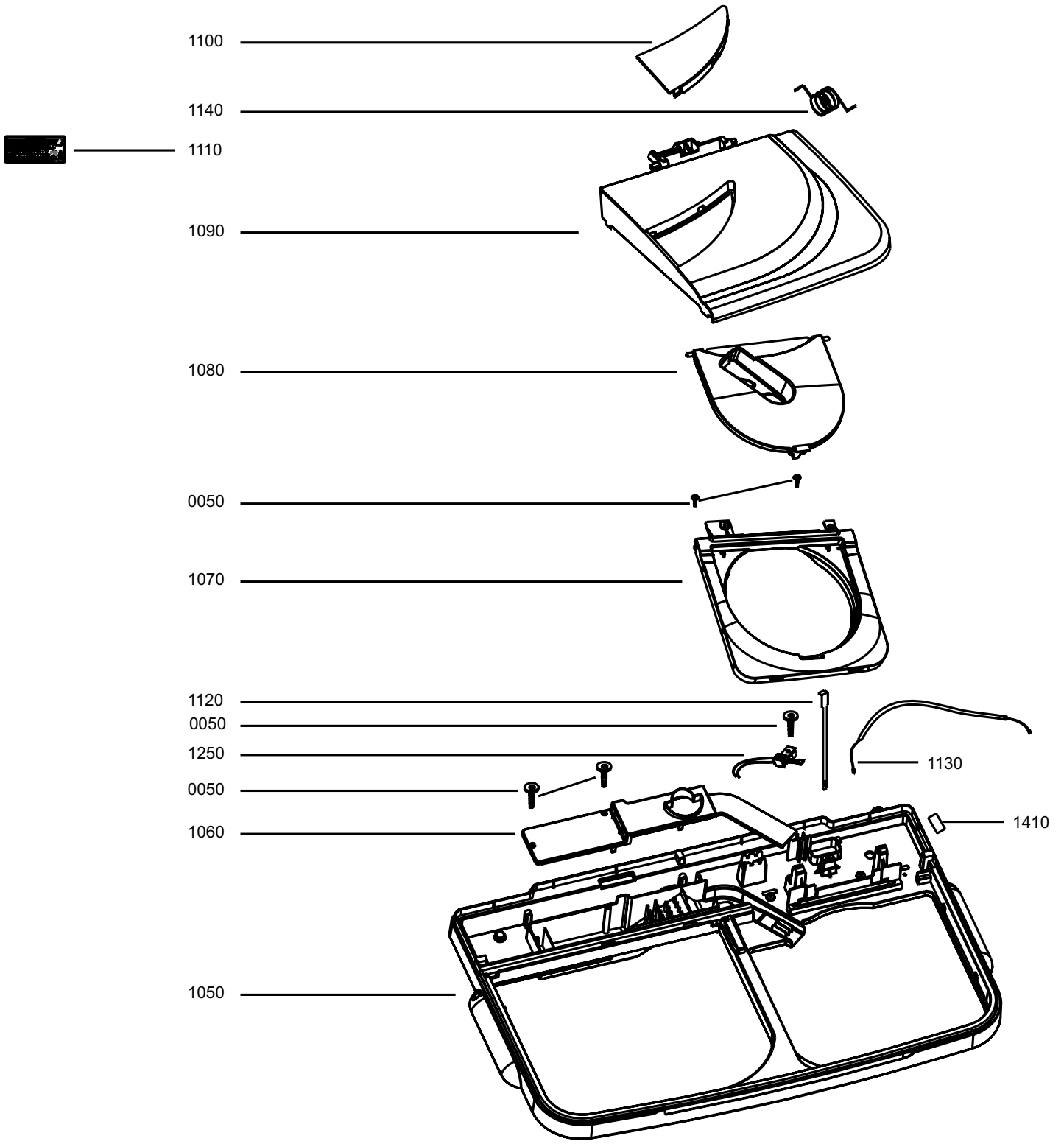

7-3. TUB ASSEMBLY

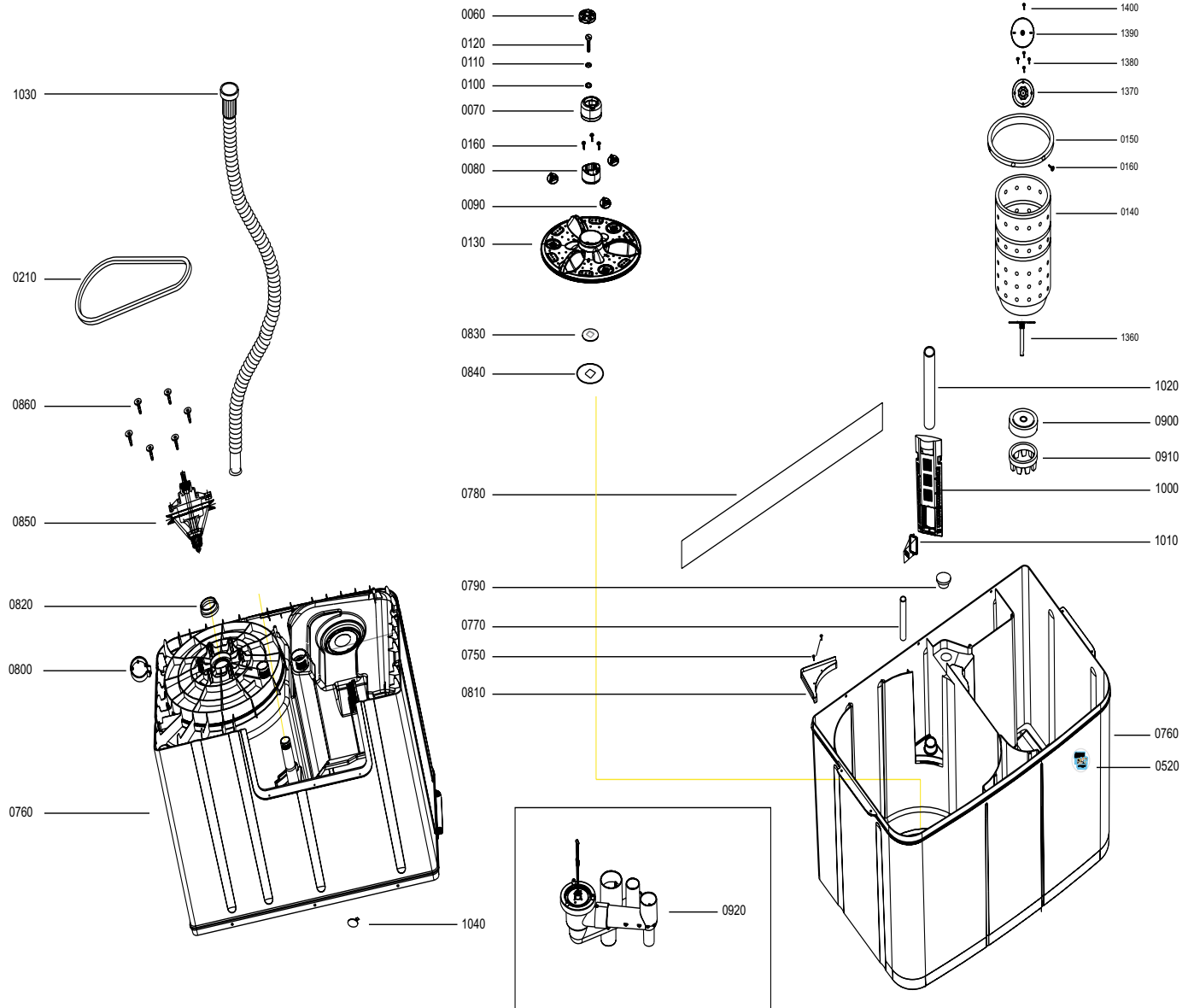

7-4. BASE ASSEMBLY

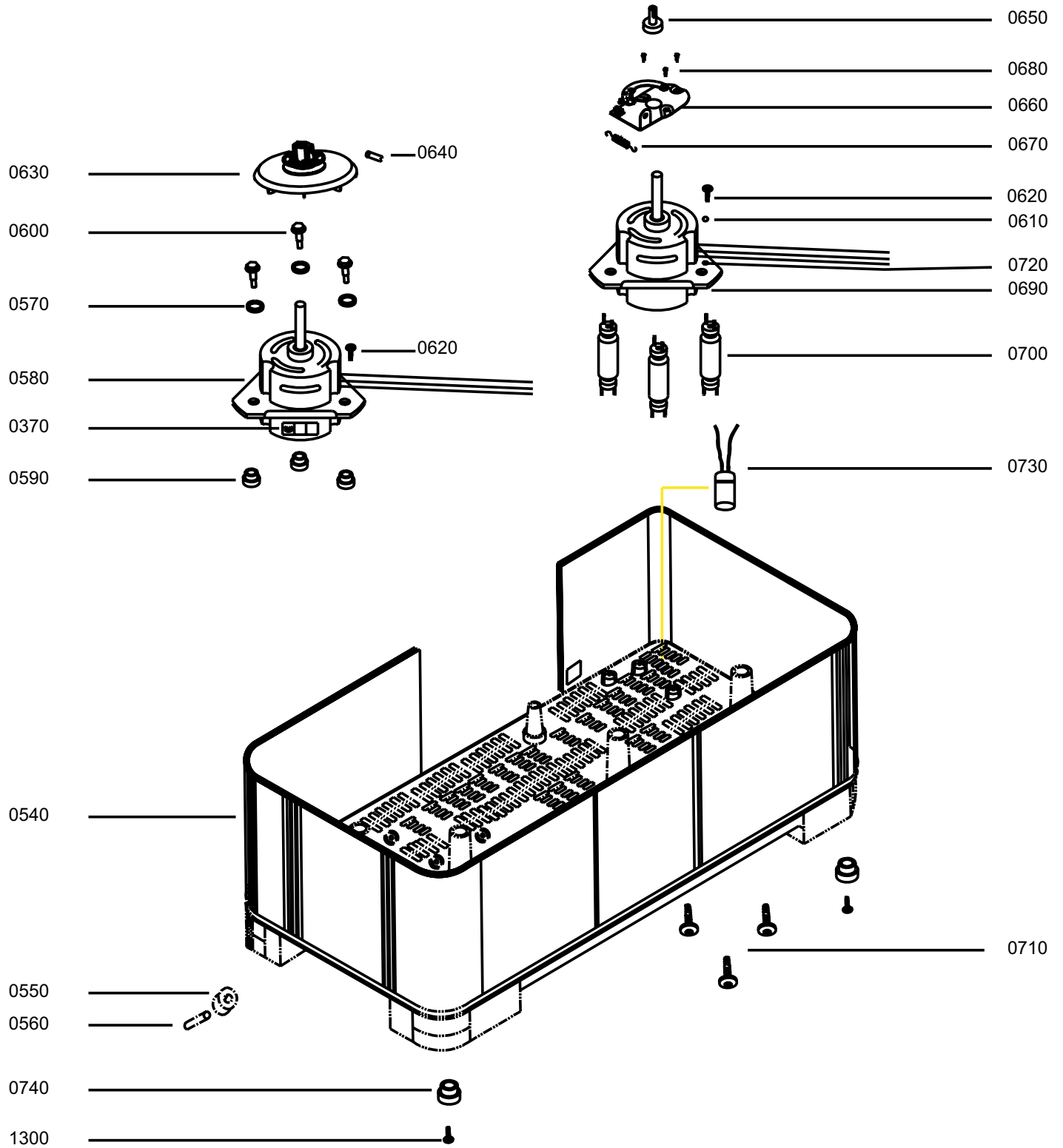

7. EXPLODED VIEW

7-5. MAIN LINE ASSY - 1

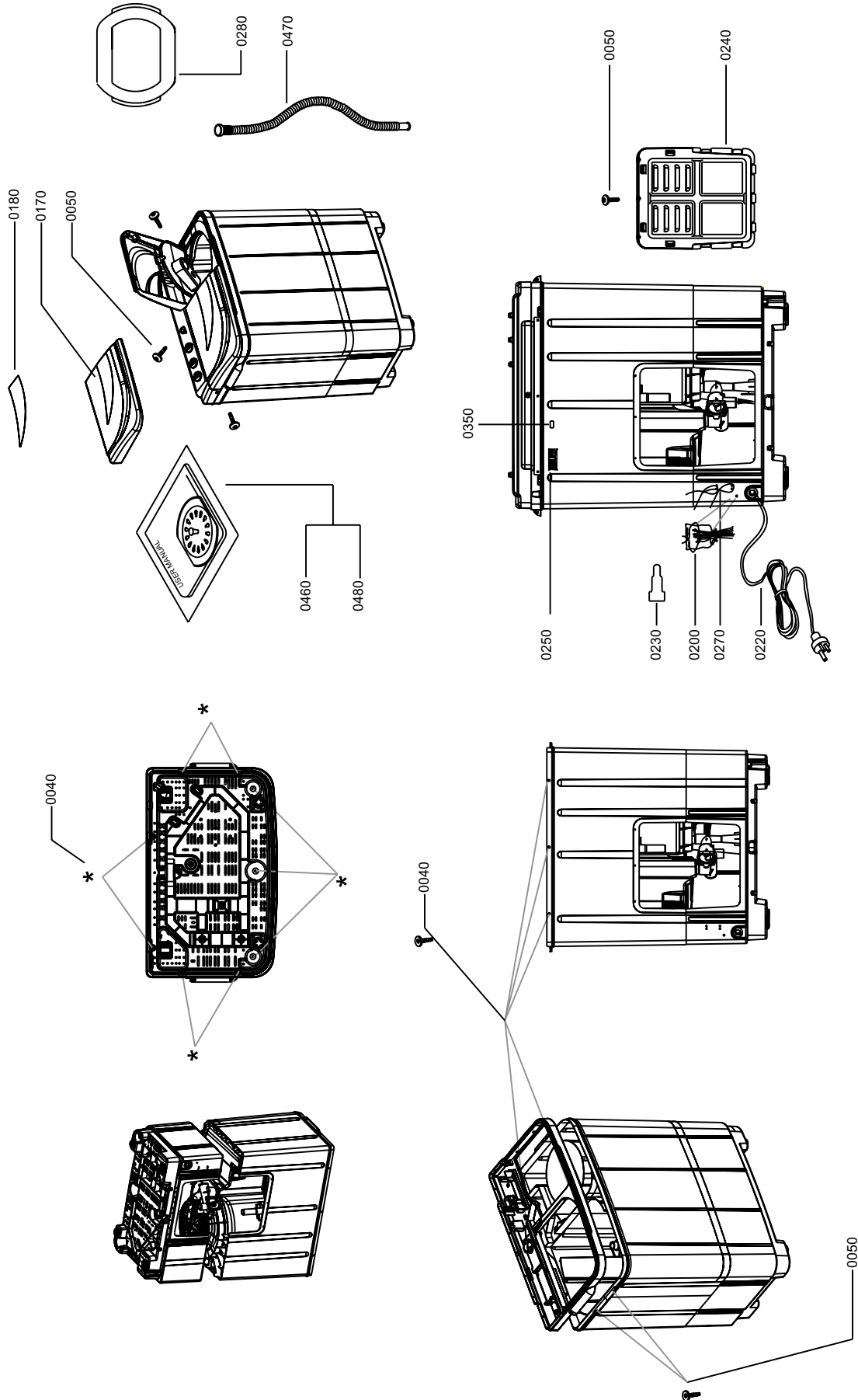

7. EXPLODED VIEW

7-6. MAIN LINE ASSY - 2

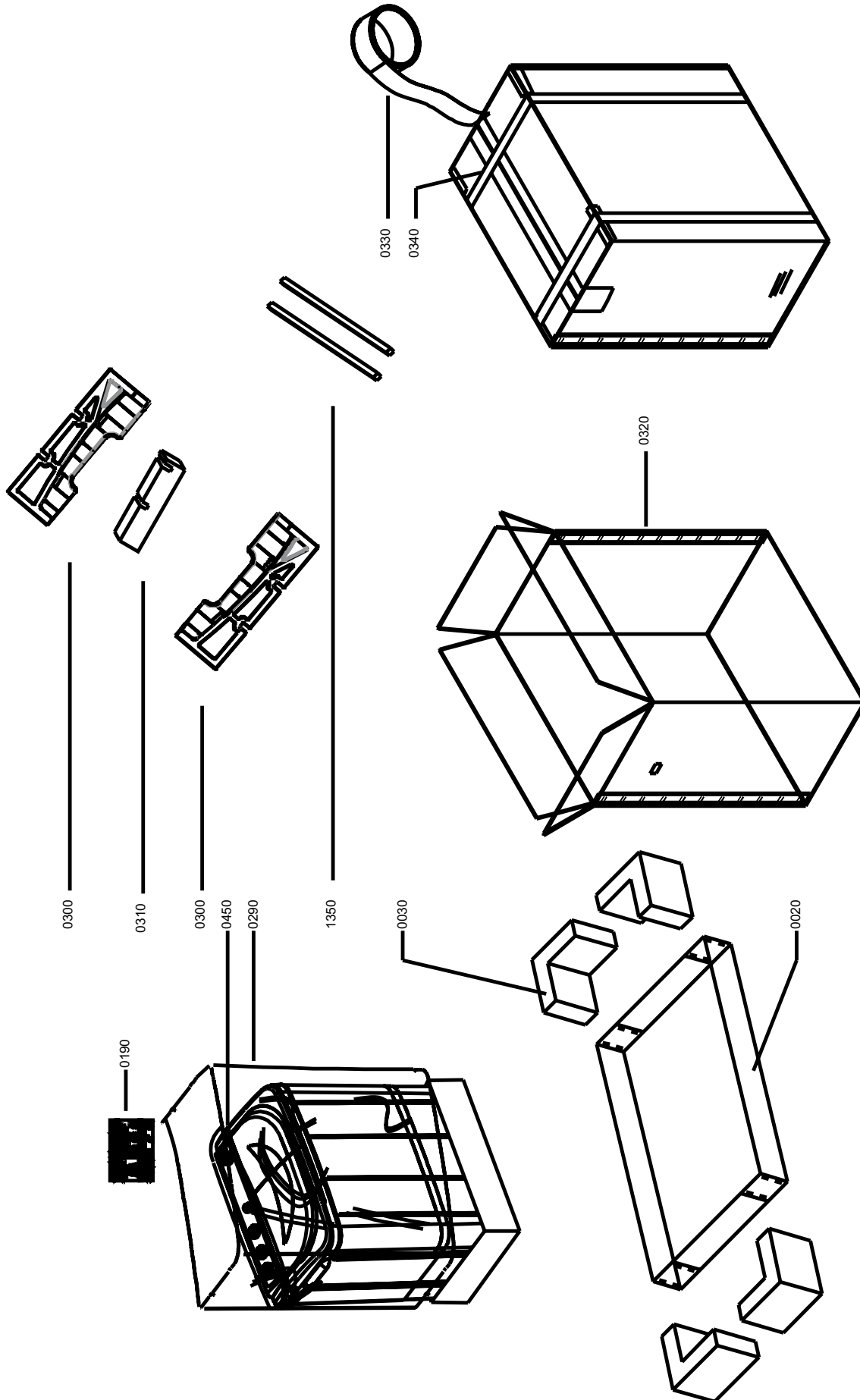

BILL OF MATERIAL

Exploded View Code	Model		MODEL: SPRING 7.0KG,LIGHT GREY (WM VSP70LPW-SFK)		MODEL: SPRING 7.0KG,PINK FUSION (WM VSP70PPW-SFK)		S BOM
	QTY	UNIT	SAP CODE	DESCRIPTION	SAP CODE	DESCRIPTION	
0510	1	PC	1100045167	STICKER,PVC,GERM & RUST,FREE,SA COMMON	1100045167	STICKER,PVC,GERM & RUST,FREE,SA COMMON	
0390	0.3	G	1400000124	ACRABOND,998	1400000124	ACRABOND,998	
0400	0.5	G	1400000334	GREASE,MOLYKOTE,G4500	1400000334	GREASE,MOLYKOTE,G4500	
0430	0.5	G	1400000131	GREASE,OKS LC PREMIUM	1400000131	GREASE,OKS LC PREMIUM	
0440	2	G	1400000125	ACRABOND,999	1400000125	ACRABOND,999	
0530	10	G	1400002189	ACRABOND,997,07 07,PURPLE COLOUR	1400002189	ACRABOND,997,07 07,PURPLE COLOUR	
0020	1	PC	1300000868	SHEET,CORRUGATED,BOTTOM,5PLY,MULTIE 6800	1300000868	SHEET,CORRUGATED,BOTTOM,5PLY,MULTIE 6800	
0030	1	PC	1300003965	BUFFER,THERMOCOL,BOTTOM,4PC,MULTIE 6800	1300003965	BUFFER,THERMOCOL,BOTTOM,4PC,MULTIE 6800	
0040	15	PC	1100005281	SCREW,BIND,TAPPING,M4X14.5,6800	1100005281	SCREW,BIND,TAPPING,M4X14.5,6800	
0050	9	PC	1100000922	SCREW,SPECIAL,TAPPING,XTB4+12C	1100000922	SCREW,SPECIAL,TAPPING,XTB4+12C	
0160	3	PC	1100006700	SCREW,BIND,TAPPING,10BU	1100006700	SCREW,BIND,TAPPING,10BU	
0130	1	PC	1200031516	PULSATOR,PUNCH,MARINE,LIGHT GREY	1200032233	PULSATOR,PUNCH,MARINE,PARKER WHITE	Y
0080	1	PC	1100021128	CAM,PUNCH PULSATOR,MULTIE 6800 S DLX	1100021128	CAM,PUNCH PULSATOR,MULTIE 6800 S DLX	
0070	1	PC	1100045008	FOLLOWER,PUNCH PULSATOR, VG GREY,MARINE	1100049379	FOLLOWER,PUNCH PULSATOR, PINK,MARINE	
0060	1	PC	1100048679	CROWN,PUNCH,PULSATOR,MARINE,LIGHT GREY	1100049380	CROWN,PUNCH,PULSATOR,MARINE,PARKER WHITE	
0090	3	PC	1100043833	ROTOR,WITH TAB,MULTIE 6800,VG GREY	1100031520	ROTOR,WITH TAB,MULTIE 6800P,LIGHT PINK	
0210	1	PC	1100029807	V BELT,L688MM,MULTIE 6000	1100029807	V BELT,L688MM,MULTIE 6000	Y
0220	1	PC	1100006692	MAINS CORD,5A/250V,MULTIE 6800	1100006692	MAINS CORD,5A/250V,MULTIE 6800	
0270	5	PC	1100000705	HOLDER,LEAD WIRE,1.4X170 MM,COMMON	1100000705	HOLDER,LEAD WIRE,1.4X170 MM,COMMON	
0280	1	PC	1300003416	BUFFER,THERMOCOL,SPIN TUB,MULTIE6800DLX	1300003416	BUFFER,THERMOCOL,SPIN TUB,MULTIE6800DLX	
0380	0.6	M	1100043686	TAPE INSULATION, PVC, BLACK, W19MM	1100043686	TAPE INSULATION, PVC, BLACK, W19MM	
0230	8	PC	1100000618	CONNECTOR A,COMMON	1100000618	CONNECTOR A,COMMON	
0200	1	G	1100005202	BAG,POLYETHYLENE,CONNECTOR,MULTIE 6800	1100005202	BAG,POLYETHYLENE,CONNECTOR,MULTIE 6800	
0240	1	PC	1200027662	COVER,BACK,MULTIE 6800,VG GREY	1200027662	COVER,BACK,MULTIE 6800,VG GREY	Y
0250	1	PC	1100054702	STICKER,WIRING DIAGRAM,SPRING,7.0KG	1100054702	STICKER,WIRING DIAGRAM,SPRING,7.0KG	
0480	1	PC	1100054703	INSTRUCTION MANUAL,MARINE PLUS, SPRING	1100054703	INSTRUCTION MANUAL,MARINE PLUS, SPRING	
0190	1	PC	1100021350	SHEET,INSTRUCTION,MULTIE 6800/SA63	1100021350	SHEET,INSTRUCTION,MULTIE 6800/SA63	
0170	1	PC	1200031517	LID,WASH,MULTIE 6800 DLX,LIGHT GREY	1200032240	LID,WASH,MULTIE 6800 DLX, PARKER WHITE	
0180	1	PC	1200031518	INSERT,WASH LID,MARINE,TRANS SMOKE GREY	1200032235	INSERT,WASH LID,MARINE,TRANSPARENT	
0460	1	PC	1100005216	CAP A,SPIN,MULTIE 6800,NATURAL	1100005216	CAP A,SPIN,MULTIE 6800,NATURAL	
0470	1	PC	1100000729	HOSE A,INLET,SA,COMMON,GREY	1100000729	HOSE A,INLET,SA,COMMON,GREY	
0350	1	PC	1100000981	STICKER,PAPER,TESTED OK,COMMON	1100000981	STICKER,PAPER,TESTED OK,COMMON	
0450	1	PC	1300007242	SHEET,FOAM,PE,750X150X1MM	1300007242	SHEET,FOAM,PE,750X150X1MM	
0290	0.05	KG	1300000860	BAG,POLYETHYLENE,MACHINE,MULTIE 6800	1300000860	BAG,POLYETHYLENE,MACHINE,MULTIE 6800	
0300	1	PC	1300008333	BUFFER,THERMOCOL,TOP,SPARKLE,7.0KG	1300008333	BUFFER,THERMOCOL,TOP,SPARKLE,7.0KG	
0310	1	PC	1300008334	BUFFER,THERMOCOL,MIDDLE,SPARKEL,7.0KG	1300008334	BUFFER,THERMOCOL,MIDDLE,SPARKEL,7.0KG	
1350	1	PC	1300003968	WOODEN,STICK,25X14X755MM,MULTIE 6800	1300003968	WOODEN,STICK,25X14X755MM,MULTIE 6800	
0320	1	PC	1300007627	BOX,PACKING,3PLY,PRINTED,MARINE/DLX PLUS	1300007627	BOX,PACKING,3PLY,PRINTED,MARINE/DLX PLUS	
0330	1	M	1300000867	TAPE,BOPP,60MMX65M,TRANSPARENT	1300000867	TAPE,BOPP,60MMX65M,TRANSPARENT	
0340	6.2	M	1300002820	STRAP,PP,15 X 0.7MM	1300002820	STRAP,PP,15 X 0.7MM	
1410	1	PC	1100043048	STICKER,VINYL,SERVICE,VIDEOCON	1100043048	STICKER,VINYL,SERVICE,VIDEOCON	
0140	1	PC	1200031519	TUB,SPIN,MULTIE 6800,SA63,LIGHT GREY	1200031519	TUB,SPIN,MULTIE 6800,SA63,LIGHT GREY	
1360	1	PC	1100019014	UNIT,COUPLING,SHAFT 108.4,METAL,6800	1100019014	UNIT,COUPLING,SHAFT 108.4,METAL,6800	
1370	1	PC	1100005270	PLATE,SPIN TUB,6800	1100005270	PLATE,SPIN TUB,6800	
1380	4	PC	1100005280	SCREW,ASSEMBLED,624	1100005280	SCREW,ASSEMBLED,624	
1390	1	PC	1100005226	COVER,SPIN TUB BOTTOM,6800	1100005226	COVER,SPIN TUB BOTTOM,6800	
1400	1	PC	1100005283	SCREW,PAN HEAD,XSN4+6BNS,6800	1100005283	SCREW,PAN HEAD,XSN4+6BNS,6800	
0150	1	PC	1200031520	BALANCER,SINGLE,MULTIE 6800,LIGHT GREY	1200031520	BALANCER,SINGLE,MULTIE 6800,LIGHT GREY	

BILL OF MATERIAL

0160	4	PC	1100006700	SCREW,BIND,TAPPING,10BU	1100006700	SCREW,BIND,TAPPING,10BU	
ASM			1100040694	UNIT,SCREW 673,O RING,WASHER 651,6800	1100040694	UNIT,SCREW 673,O RING,WASHER 651,6800	Y
0100	1	PC	1100005261	O RING,PULSATOR,SA 63,MULTIE 6800	1100005261	O RING,PULSATOR,SA 63,MULTIE 6800	
0110	1	PC	1100005315	WASHER,SPECIAL,651	1100005315	WASHER,SPECIAL,651	
0120	1	PC	1100005289	SCREW,SPECIAL,673,6800	1100005289	SCREW,SPECIAL,673,6800	
ASM			1200032258	ASSY,BASE A,MARINE / DLX PLUS,VG GREY	1200032400	ASSY,BASE A,MARINE/DLX PLUS 7.0,PINK FUS	
ASM			1200031416	ASSY,TUB A,MARINE/DLX PLUS, LIGHT GREY	1200032399	ASSY,TUB A,MARINE PLUS, PARKER WHITE	
ASM			1200032259	ASSY,BODY B,MARINE / DLX PLUS,VG GREY	1200032396	ASSY,BODY B,MARINE/DLX PLUS,PINK FUS	
ASM			1200035223	ASSY,PANEL A,SPRING7.0KG,L GREY,ECO WASH	1200035224	ASSY,PANEL A,SPRING 7.0KG, PARKER WT.ECO	
ASM			1200032258	ASSY,BASE A,MARINE / DLX PLUS,VG GREY	1200032400	ASSY,BASE A,MARINE/DLX PLUS 7.0,PINK FUS	
0540	1	PC	1200027866	BASE A,MARINE/MARINE DLX,VG GREY	1200032236	BASE A,MARINE/MARINE,PINK	Y
0260	2	PC	1100006687	HOLDER,LEAD WIRE,1.4X90 MM,COMMON	1100006687	HOLDER,LEAD WIRE,1.4X90 MM,COMMON	
0550	2	PC	1100005221	CASTOR WHEEL,SA63,MULTIE 6800	1100005221	CASTOR WHEEL,SA63,MULTIE 6800	
0560	2	PC	1100005290	SHAFT,CASTOR,MULTIE 6800	1100005290	SHAFT,CASTOR,MULTIE 6800	
0570	3	PC	1100001074	WASHER B,MOTOR,741	1100001074	WASHER B,MOTOR,741	Y
0580	1	PC	1200000379	MOTOR,125W	1200000379	MOTOR,125W	Y
0590	3	PC	1100019019	UNIT,MOTOR WASHER A,613,SA63/43	1100019019	UNIT,MOTOR WASHER A,613,SA63/43	Y
0600	3	PC	1100005286	SCREW,SPECIAL,TAPPING,515,6800	1100005286	SCREW,SPECIAL,TAPPING,515,6800	
0630	1	PC	1100048296	UNIT,MOTOR PULLEY,FAN,SCREW,6800,G BOX	1100048296	UNIT,MOTOR PULLEY,FAN,SCREW,6800,G BOX	Y
0640	1	PC	1100000931	SCREW,STOP,XXE08C12,SA63	1100000931	SCREW,STOP,XXE08C12,SA63	
0650	1	PC	1100034613	BRAKE WHEEL,CI,60MM,MULTIE 6800,WTH BOLT	1100034613	BRAKE WHEEL,CI,60MM,MULTIE 6800,WTH BOLT	Y
0660	1	PC	1100019012	UNIT,SPIN MOTOR PLATE,SA43	1100019012	UNIT,SPIN MOTOR PLATE,SA43	Y
0670	1	PC	1100000957	SPRING,BRAKE,SA43,MULTIE 6800	1100000957	SPRING,BRAKE,SA43,MULTIE 6800	
0680	3	PC	1100005282	SCREW,PAN HEAD,XSN4+6S,6800	1100005282	SCREW,PAN HEAD,XSN4+6S,6800	
0690	1	PC	1200003202	MOTOR,45W	1200003202	MOTOR,45W	Y
0700	3	PC	1100017314	UNIT,SUSPENSION,BUFFER,HOLDER A,B,SA63	1100017314	UNIT,SUSPENSION,BUFFER,HOLDER A,B,SA63	Y
0710	3	PC	1100006698	SCREW,SPECIAL,TAPPING,25A	1100006698	SCREW,SPECIAL,TAPPING,25A	
0720	1	PC	1100005316	LEAD,WIRE,GREEN,600MM,EARTH,MULTIE 6800	1100005316	LEAD,WIRE,GREEN,600MM,EARTH,MULTIE 6800	
0620	1	PC	1100005279	SCREW,5X12	1100005279	SCREW,5X12	
0730	1	PC	1100005220	CAPACITOR,FILM,240V,9.5+4.0MFD,J	1100005220	CAPACITOR,FILM,240V,9.5+4.0MFD,J	Y
0740	2	PC	1100036791	UNIT,RUBBER LEG,WASHER 592,MULTIE 6800	1100036791	UNIT,RUBBER LEG,WASHER 592,MULTIE 6800	Y
1300	2	PC	1100028631	SCREW,MS,SPECIAL,TAPPING,435	1100028631	SCREW,MS,SPECIAL,TAPPING,435	
0610	1	PC	1100001089	WASHER,SPECIAL,608,FA55/61/71	1100001089	WASHER,SPECIAL,608,FA55/61/71	
ASM			1200031416	ASSY,TUB A,MARINE/DLX PLUS, LIGHT GREY	1200032399	ASSY,TUB A,MARINE PLUS, PARKER WHITE	
0760	1	PC	1200031521	TUB A,MARINE/MARINE DLX,LIGHT GREY	1200032234	TUB A,MARINE/MARINE DLX,PARKER WHITE	
0800	1	PC	1100028307	CAP,TUB,BOTTOM,MULTIE 6800,NATURAL	1100028307	CAP,TUB,BOTTOM,MULTIE 6800,NATURAL	
0810	1	PC	1100048781	CAP,TUB,MARINE/MARINE DLX,LIGHT GREY	1100049381	CAP,TUB,MARINE,PARKER WHITE	
0820	1	PC	1100005309	WASHER,BEARING CASE A,MULTIE 6800	1100005309	WASHER,BEARING CASE A,MULTIE 6800	
0830	1	PC	1100005266	PACKING,MECHANISM CASE,RUBBER,MULTIE6800	1100005266	PACKING,MECHANISM CASE,RUBBER,MULTIE6800	
0840	1	PC	1100005212	BUSHING,SHAFT,MULTIE 6800	1100005212	BUSHING,SHAFT,MULTIE 6800	
0850	1	PC	1100042752	GEAR BOX,ASSY,WITH PULLY,MULTIE 6800	1100042752	GEAR BOX,ASSY,WITH PULLY,MULTIE 6800	Y
0860	6	PC	1100005285	SCREW,SPECIAL,TAPPING,514,6800	1100005285	SCREW,SPECIAL,TAPPING,514,6800	
0900	1	PC	1100021349	UNIT,BUFFER OUTER,BUSH,6800/SA63	1100021349	UNIT,BUFFER OUTER,BUSH,6800/SA63	Y
0910	1	PC	1100005240	HOLDER A,BUFFER,MULTIE 6800	1100005240	HOLDER A,BUFFER,MULTIE 6800	
1030	1	PC	1100005242	HOSE B,FLEXIBLE,DRAIN,MULTIE 6800	1100005242	HOSE B,FLEXIBLE,DRAIN,MULTIE 6800	
1040	1	PC	1100005264	PACKING,CHECK VALVE,RUBBER,6800	1100005264	PACKING,CHECK VALVE,RUBBER,6800	
1020	1	PC	1100006695	PIPE,OVERFLOW,230MM,6800	1100006695	PIPE,OVERFLOW,230MM,6800	
0780	1	PC	1100019553	FOAM,PE,1100X20X2MM,MULTIE 6800DLX	1100019553	FOAM,PE,1100X20X2MM,MULTIE 6800DLX	
1010	1	PC	1100005228	FILTER,UNIT,MULTIE 6800,APPLIANCES GREY	1100031519	FILTER,UNIT,MULTIE 6800P,CREAM WHITE	Y
1000	1	PC	1100005229	FILTER,OVER FLOW,6800,DARK GREY	1100031518	FILTER,OVER FLOW,MULTIE 6800P,WHITE	Y

BILL OF MATERIAL

0770	1	PC	1100005267	PIPE,FEEDING PORT SUPPORT,6800	1100005267	PIPE,FEEDING PORT SUPPORT,6800	
0790	1	PC	1100042802	CAP,NOZZLE,RUBBER,CHINA,MULTIE 6800	1100042802	CAP,NOZZLE,RUBBER,CHINA,MULTIE 6800	
0811	2	PC	1100005287	SCREW,SPECIAL,TAPPING,435	1100005287	SCREW,SPECIAL,TAPPING,435	
ASM			1200032259	ASSY,BODY B,MARINE / DLX PLUS,VG GREY	1200032396	ASSY,BODY B,MARINE/DLX PLUS,PINK FUS	
1050	1	PC	1200027867	BODY B,MARINE/MARINE DLX,VG GREY	1200032243	BODY B,MARINE/MARINE DLX,PINK	
1060	1	PC	1100019311	COVER,NOZZLE,MULTIE 6800 DLX	1100019311	COVER,NOZZLE,MULTIE 6800 DLX	
0050	2	PC	1100000922	SCREW,SPECIAL,TAPPING,XTB4+12C	1100000922	SCREW,SPECIAL,TAPPING,XTB4+12C	
1070	1	PC	1200030998	COVER,OUTER TUB,MULTIE 6800,LIGHT GREY	1200032232	COVER,OUTER TUB,MULTIE 6800,PARKER WHITE	
0040	2	PC	1100005281	SCREW,BIND,TAPPING,M4X14.5,6800	1100005281	SCREW,BIND,TAPPING,M4X14.5,6800	
1080	1	PC	1200013715	LID,INNER,MULTIE 6800 DLX,NATURAL	1200013715	LID,INNER,MULTIE 6800 DLX,NATURAL	
1130	1	PC	1100019404	FLEXIBLE,WIRE,UNIT,MULTIE 6800 DLX	1100019404	FLEXIBLE,WIRE,UNIT,MULTIE 6800 DLX	Y
1140	1	PC	1100019319	SPRING,LID HINGE,MULTIE 6800 DLX	1100019319	SPRING,LID HINGE,MULTIE 6800 DLX	
1250	1	PC	1100019324	SWITCH,SAFETY,MULTIE 6800 DLX	1100019324	SWITCH,SAFETY,MULTIE 6800 DLX	Y
1120	1	PC	1100005257	LEVER A,ACTUATING,MULTIE 6800	1100005257	LEVER A,ACTUATING,MULTIE 6800	
1090	1	PC	1200031522	LID,SPIN,MULTIE 6800 DLX,LIGHT GREY	1200032239	LID,SPIN,MULTIE 6800 DLX, PARKER WHITE	
1100	1	PC	1200031523	INSERT,SPIN LID,MARINE,TRANS SMOKE GREY	1200032238	INSERT,SPIN LID,MARINE,TRANSPARENT	
1110	1	PC	1100005299	STICKER,CAUTION,MULTIE 6800	1100005299	STICKER,CAUTION,MULTIE 6800	
ASM			1200035223	ASSY,PANEL A,SPRING7.0KG,L GREY,ECO WASH	1200035224	ASSY,PANEL A,SPRING 7.0KG, PARKER WT.ECO	Y
1150	1	PC	1200035156	PANEL A,SPRING,7.0KG,W/P,LIGHT GREY	1200035157	PANEL A,SPRING,7.0KG,W/P,PARKER WHITE	
1151			1200035152	DECO, PANEL A,SPRING,7.0KG,PRIN,LT GREY	1200035153	DECO, PANEL A,SPRING,7.0KG,PRIN,PINK	Y
1160	1	PC	1200035162	PLATE,TIMER,SPRING, 7.0KG	1200035162	PLATE,TIMER,SPRING, 7.0KG	
0050	5	PC	1100000922	SCREW,SPECIAL,TAPPING,XTB4+12C	1100000922	SCREW,SPECIAL,TAPPING,XTB4+12C	
1170	1	PC	1100019530	TIMER,WASH,40MIN,1SHAFT,MECHANICAL,DLX	1100019530	TIMER,WASH,40MIN,1SHAFT,MECHANICAL,DLX	Y
0040	1	PC	1100005281	SCREW,BIND,TAPPING,M4X14.5,6800	1100005281	SCREW,BIND,TAPPING,M4X14.5,6800	
1180	1	PC	1100019531	TIMER,SPIN,MULTIE 6000/6800 DLX	1100019531	TIMER,SPIN,MULTIE 6000/6800 DLX	Y
1300	2	PC	1100028631	SCREW,MS,SPECIAL,TAPPING,435	1100028631	SCREW,MS,SPECIAL,TAPPING,435	
1200	1	PC	1100005214	BUZZER WITHOUT KNOB,WITHOUT CASTOR	1100005214	BUZZER WITHOUT KNOB,WITHOUT CASTOR	Y
1220	2	PC	1100006701	SCREW,BIND,TAPPING,XTB3+12C,SA63/6800	1100006701	SCREW,BIND,TAPPING,XTB3+12C,SA63/6800	
1240	1	PC	1200013714	LEVER A,DRAIN,MULTIE 6800 DLX	1200013714	LEVER A,DRAIN,MULTIE 6800 DLX	
1190	1	PC	1100005295	SPRING,FLAT,50.5MM,6800	1100005295	SPRING,FLAT,50.5MM,6800	
1230	0.86	M	1100009335	POLYESTER STRIP,6MMX2000M	1100009335	POLYESTER STRIP,6MMX2000M	
1310	1	PC	1100048782	HANGER A,FEED HOSE,MARINE/DLX,LIGHT GREY	1100049377	HANGER A,FEED HOSE,MARINE, PARKER WHITE	
0160	2	PC	1100006700	SCREW,BIND,TAPPING,10BU	1100006700	SCREW,BIND,TAPPING,10BU	
1320	1	PC	1100054704	FEEDING, PORT A, SPRING, 7.0KG	1100054704	FEEDING, PORT A, SPRING, 7.0KG	
1330	1	PC	1100054705	LEVER,FEEDING PORT,SPRING LIGHT GREY	1100054709	LEVER,FEEDING PORT,SPRING, PARKER WHITE	
1340	1	PC	1100019317	O RING,FEED HOSE HANGER A,MULTIE 6800DLX	1100019317	O RING,FEED HOSE HANGER A,MULTIE 6800DLX	
1270	1	PC	1100005300	STICKER,EXCESS FLOW,MULTIE 6800	1100005300	STICKER,EXCESS FLOW,MULTIE 6800	
0920			1100044148	UNIT,VALVE FRAME,MULTIE 6800,THREAD LID	1100044148	UNIT,VALVE FRAME,MULTIE 6800,THREAD LID	Y
ASM			1100054706	UNIT,TIMER KNOB,SPRING,LIGHT GREY	1100054710	UNIT,TIMER KNOB,DECO,SPRING,PARKER WHITE	Y
1280	4	PC	1100054707	TIMER KNOB BODY,SPRING,7.0KG,LIGHT GREY	1100054711	TIMER KNOB BODY,SPRING,7.0KG,PARKER WHITE	
1290	4	PC	1100054708	TIMER KNOB DECO, SPRING, CROME PLT	1100054708	TIMER KNOB DECO, SPRING, CROME PLT	

Experience Change



Committed to You. Committed to Nature

Committed to Service. At Videocon, service commitment is of utmost priority, which is why our dedication goes beyond the conventional. For us, service is not just about keeping products at their operational best, but also the beginning of a binding relationship. With more than 350 customer care points spread across the country to address your needs, we are just a call away. Our endeavour is to foster a bigger cause by keeping our products Eco-Fit.

VIDEOCON INDUSTRIES LIMITED

Reg. Office: Videocon Industries Ltd., 14 kms. Stone, Aurangabad-Paithan Road, Chitegaon, Tq, Paithan, Dist. Aurangabad-431 105 (India). Phone No.: 02341-251501/02/03/04

Corporate Office: Plot No. 248, Udyog Vihar, Phase - 4, Gurgaon - 122015, Phone No.: 0124-4215400

For more details visit us at www.videoconworld.com. For online shopping visit us at www.edigiworld.com
You could write to us at marketing@vgmail.in. For service issues write to us at customer care@vgmail.in or
SMS SVC to 53030