



# INSTRUCTIONS

-J05674

REV. 2013-07-31

## SCREAMIN' EAGLE BIG TWIN COMPENSATOR

### GENERAL

#### Kit Number

42200064, 42200095

#### Models

This kit fits:

- 2006 and later Dyna
- 2007 and later Touring
- 2007 and later Softail

#### Additional Parts Required

- A new primary cover gasket must be ordered separately for the proper installation of this kit.
- Oil Deflector Installation Kit (Part No. 11100088). Available to dealers only.
- Rotor (Part No. 30041-08A): 2006-2011 Dyna, 2007-2011 Softail (except 2008-2009 FXCW, 2008-2011 FXCWC, 2009 FXSTSSE3, 2010 FXSTSE and 2011 FXSTSE2) and 2007-2010 Touring models.
- Stator (Part No. 30017-07): 2006 Dyna

#### Tools and Supplies Required

Caulk Gun Conversion Kit (Part No. 11100075).

Primary Drive Locking Tool:

- 2007-Later Touring models (Part No. H-D-48219).
- 2006-Later Dyna and 2007-later Softail models (Part No. HD-47977).

### WARNING

The rider's safety depends upon the correct installation of this kit. Use the appropriate service manual procedures. If the procedure is not within your capabilities or you do not have the correct tools, have a Harley-Davidson dealer perform the installation. Improper installation of this kit could result in death or serious injury. (00333a)

#### NOTE

This instruction sheet references service manual information. A service manual for your year and model motorcycle is required for this installation and is available from a Harley-Davidson dealer.

#### Kit Contents

See Figure 7 and Table 1.

### REMOVAL

#### WARNING

To prevent accidental vehicle start-up, which could cause death or serious injury, disconnect battery cables (negative (-) cable first) before proceeding. (00307a)

1. Remove the seat and disconnect the battery cables, negative cable first, as outlined in the service manual. Retain all seat mounting hardware.
2. Remove the drive components as outlined in the service manual.
3. **2006-2011 Dyna, 2007-2011 Softail (except 2008-2009 FXCW, 2008-2011 FXCWC, 2009 FXSTSSE3, 2010 FXSTSE and 2011 FXSTSE2) and 2007-2010 Touring models:** Remove the alternator rotor as outlined in the service manual.
4. **2006 Dyna:** Replace stator with **new** stator (Part No. 30017-07) as outlined in the service manual.

### INSTALLATION

Before beginning, read and understand the MSDS for the adhesive used in the Oil Rib Installation Kit. Use only as instructed. Use appropriate safety equipment and gloves. Properly dispose of used application tip and replace cap.

1. See Figure 1. Assemble adhesive cartridge and Caulk Gun Conversion Kit (Part No. 11100075) into caulk gun (not provided).



Figure 1. Caulk Gun and Adapter

2. Clean primary cover with PJ-1 or equivalent. Wipe the deflector installation area with rubbing alcohol to remove residue. Allow to dry completely.
3. Test fit the appropriate oil deflector to the cleaned primary cover:
  - a. Part No. 62700063 for Touring Models
  - b. Part No. 62700064 for Softail or Dyna Models

4. See Figure 2. Place oil deflector (cover side up) on a clean protected surface. Apply adhesive:
  - a. Apply adhesive to the perimeter of the part.
  - b. Create an "X" pattern across the part.
  - c. Apply adhesive to the sides that contact the primary cover.



**Figure 2. Apply Adhesive**

5. See Figure 3. Carefully position deflector in primary cover and press firmly into place. Slide deflector into position. **DO NOT** lift.
6. Install retention clip over oil deflector rib and the adjacent aluminum rib as shown.

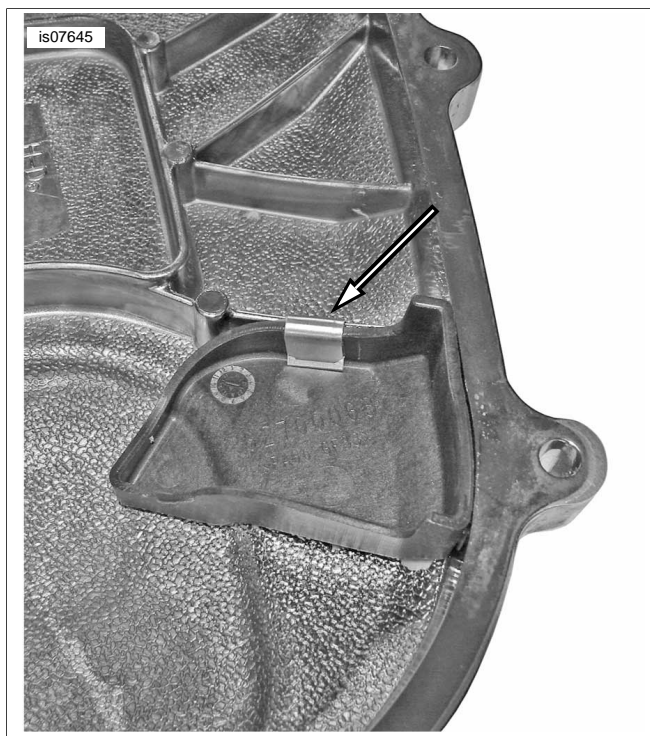

**Figure 3. Install Deflector and Retaining Clip**

7. See Figure 4. Protect the outside surface of the primary cover to avoid damage. Secure the oil deflector in place using a C-clamp. Allow approximately 30 minutes before handling.

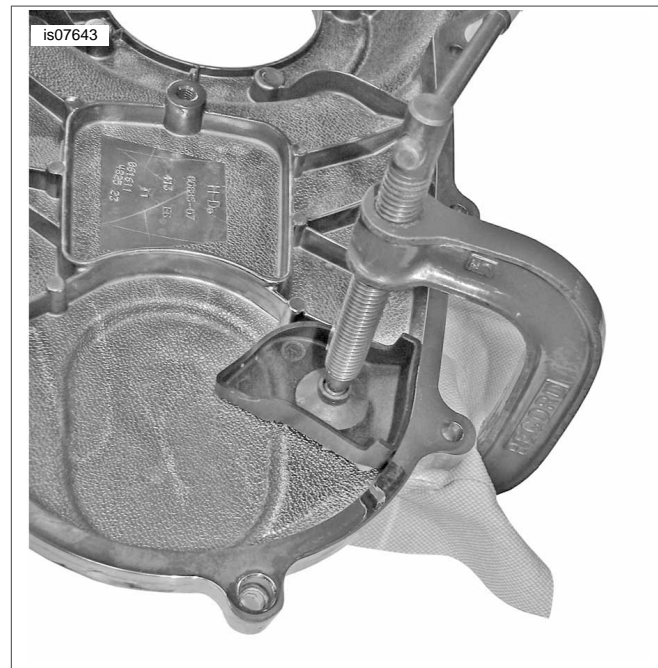

**Figure 4. Clamp Components Together**

**NOTE**

*2006-2011 Dyna, 2007-2011 Softail (except 2008-2009 FXCW, 2008-2011 FXCWC, 2009 FXSTSSE3, 2010 FXSTSE and 2011 FXSTSE2) and 2007-2010 Touring models require separate purchase of alternator rotor (Part No. 30041-08A).*

8. **2006-2011 Dyna, 2007-2011 Softail (except 2008-2009 FXCW, 2008-2011 FXCWC, 2009 FXSTSSE3, 2010 FXSTSE and 2011 FXSTSE2) and 2007-2010 Touring models:** See Figure 7. Install the **new** alternator rotor (A) to the engine compensating sprocket shaft per service manual instructions.
9. See Figure 7. Apply a thin layer of primary chaincase oil to the sliding cam (5) splines and the outer splines of shaft extension (4). Install shaft extension with the flat side against alternator rotor.
10. Install two shims (14) onto shaft extension.

**NOTE**

*Make sure shims (14) do not fall between shaft extension and alternator rotor.*

11. Remove the shipping retainer from the spring pack. Without disturbing the order, install the spring pack onto shaft extension with the two large disc springs (1) against the shim. The outer diameters of the springs must contact each other as shown in Figure 5.
12. Install the sliding cam (5) with the flat face contacting the small disc spring. Lubricate the sliding cam ramps with primary chaincase oil.

**NOTES**

- *The compensating sprocket (6) is installed with the text "this side out" facing outward.*
- *Clutch hub mainshaft nut has left-hand threads. Turn counterclockwise to install.*
- *The primary chain, compensating sprocket and clutch assembly must be installed as an assembly.*

- Place the drive components (primary chain, compensating sprocket and clutch assembly) into position. A slight rotation of the chain drive aids installation onto the splines.

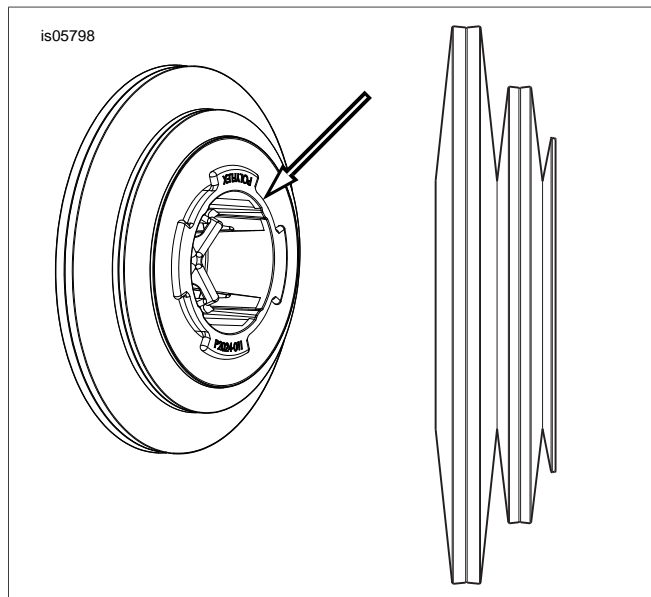

**Figure 5. Spring Pack Sub-Assembly**

- Clean and prime threads of clutch hub mainshaft nut. Apply two drops of LOCTITE 262 HIGH STRENGTH THREAD-LOCKER AND SEALANT (red) to the threads. Start nut onto mainshaft. Hand-tighten.

**NOTES**

When installing screw (10), make sure that the disc springs are properly aligned and that the spring nearest the rotor assembly has not slipped between the extension and rotor hub.

- Lightly lubricate thrust bearing (8) with a thin layer of primary chaincase oil. Install thrust washer (7), bearing (8), thrust washer (7), retainer (9) and screw (10). Hand tighten.

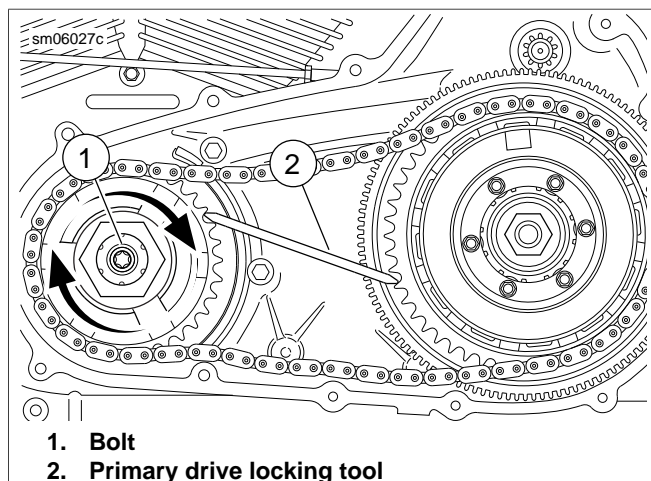

- Bolt
- Primary drive locking tool

**Figure 6. Installing Engine Compensating Sprocket Bolt**

- See Figure 6. Place the PRIMARY DRIVE LOCKING TOOL between the teeth of the engine and clutch sprockets as shown.

**NOTE**

The compensating sprocket screw is a T70 drive. Use T70 SOCKET BIT Snap-on STX70E or equivalent.

- See Figure 7. Tighten compensating sprocket screw (10) to 100 ft-lbs (135.6 Nm).

**NOTE**

Make sure shims (14) do not fall between shaft extension and alternator rotor when loosening screw.

- Loosen screw one half turn (180 degrees).
- Final tighten to 175 ft-lbs (237.3 Nm).
- FXCW/C (Rocker), FXSTSSE3 (Screamin' Eagle Softail Springer), FXSBSE (Screamin' Eagle Softail Breakout) and FXSB/FXSB103 (Breakout) models:** Install oil spinner (15) on sprocket retainer (9).
- Rotate the compensating sprocket (6) to make sure that there is a light pressure on the sprocket from the springs. No clearance should be felt. A slight rotation should be possible by hand with the transmission in neutral.
- Complete the assembly per instructions in the service manual:
  - Assemble the remaining drive components.
  - Adjust the clutch.
  - Install the primary chain tensioner.
  - Install the primary chaincase cover with a **new** gasket (sold separately).
  - Fill the primary chaincase with lubricant.

**RETURN TO SERVICE**

- Verify that the ignition/key switch is turned to the OFF position.
- Apply a light coat of Harley-Davidson electrical contact lubricant (Part No. 99861-02), petroleum jelly or corrosion retardant material to the battery terminals. Connect the battery cables (positive cable first) as outlined in the service manual.

**WARNING**

Connect positive (+) battery cable first. If positive (+) cable should contact ground with negative (-) cable connected, the resulting sparks can cause a battery explosion, which could result in death or serious injury. (00068a)

- Install the seat as outlined in the service manual.

**WARNING**

After installing seat, pull upward on seat to be sure it is locked in position. While riding, a loose seat can shift causing loss of control, which could result in death or serious injury. (00070b)

## SERVICE PARTS

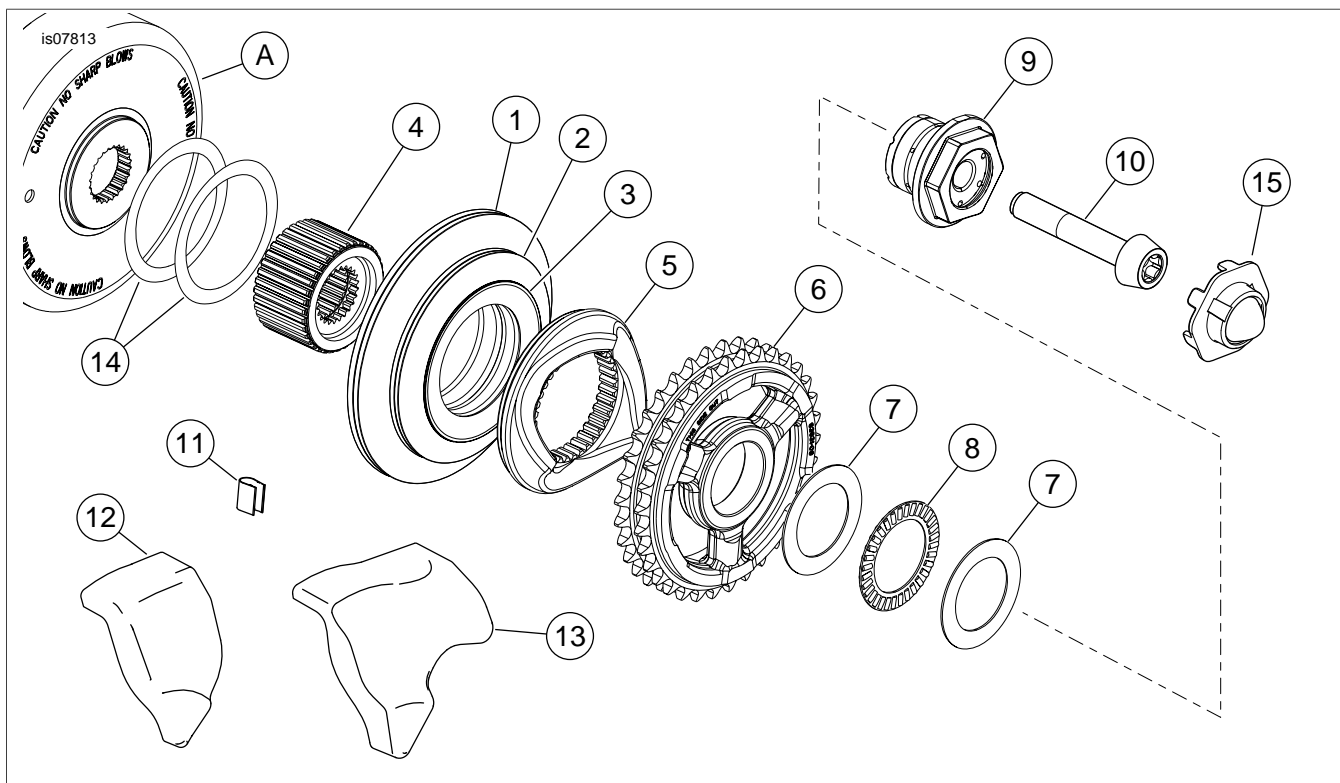

Figure 7. Service Parts: Screamin' Eagle Big Twin Compensator Kit

Table 1. Service Parts

Item	Description (Quantity)	Part Number
*	Spring Pack (includes items 1 through 3)	83936-09A
1	• Large disc spring (2)	Not sold separately
2	• Medium disc spring (2)	Not sold separately
3	• Small disc spring	Not sold separately
*	Compensator Kit, 2006 and later Dyna, 2007 and later Touring, 2007 and later Softail (except models listed below) (includes items 4 through 13)	36500034
*	Compensator Kit, FXCW/C (Rocker), FXSTSSE3 (Screamin' Eagle Softail Springer), FXSBSE (Screamin' Eagle Softail Breakout) and FXSB/FXSB103 (Breakout) models (includes items 4 through 13)	36500078
4	• Shaft extension	Not sold separately
5	• Sliding cam	Not sold separately
6	• Compensating sprocket	Not sold separately
*	• Bearing Service Kit (includes items 7 and 8)	36500079
7	• -- Thrust washer (2)	Not sold separately
8	• -- Thrust bearing	Not sold separately
9	• Sprocket retainer	Not sold separately
10	• Screw	10500031
11	• Retainer clip	12200065
12	• Oil deflector, Touring models	62700063
13	• Oil deflector, Dyna and Softail models	62700064
14	Shims, 0.031 (2)	10300021
15	Oil spinner, FXCW/C (Rocker), FXSTSSE3 (Screamin' Eagle Softail Springer), FXSBSE (Screamin' Eagle Softail Breakout) and FXSB/FXSB103 (Breakout) models only	62700062

**Table 1. Service Parts**

<b>Item</b>	<b>Description (Quantity)</b>	<b>Part Number</b>
<b>Items mentioned in text, but not included in kit:</b>		
A	Alternator rotor assembly, as required	30041-08A