



*Communications
for today... and tomorrow*

IL815
SECTION E
Rev. 13 - 09/2008

Tek-CARE[®]500 Wireless Emergency Call System

Operation, Installation and Service Manual



Alpha Communications[®]
42 Central Drive
Farmingdale, NY 11735-1202
Phone: (631) 777-5500
Fax: (631) 777-5599

Website:
www.AlphaCommunications.com

Email:
info@alphacommunications.com

TOLL-FREE Technical #:
1-800-666-4800

TekTone[®] has designed Tek-CARE[®]500 to work as a system. Its NC501 Master Station Computer has been carefully designed and matched to work with Tek-CARE[®]500 wireless and wired peripherals. TekTone[®] will not warrant or support components of Tek-CARE[®]500 that are purchased separately unless the components are add-ons to previously sold systems. TekTone[®] will also not warrant or support a system that is a mix of TekTone[®] and Non-TekTone[®] parts, unless prior permission has been obtained.

A site survey must be performed and submitted before ordering a Tek-CARE[®]500 system. In order to track our systems and to inform facilities of software upgrades, full site information (site name, address and phone number) will be required when ordering. Site information and NC501 warranty numbers will also be required when requesting technical support.

Operation, Installation and Service Manual

Copyright © 2003–2008 TekTone® Sound & Signal Mfg., Inc., All rights reserved.

No part of this publication may be copied without the express written permission of TekTone® Sound & Signal Mfg., Inc. The content of this manual is furnished for informational use only, is subject to change without notice, and should not be construed as a commitment by TekTone® Sound & Signal Mfg., Inc. TekTone® Sound & Signal Mfg., Inc. assumes no responsibility or liability for any errors or inaccuracies that may appear in this documentation.

TekTone, the TekTone logo, Tek-Call, Tek-Care, Tek-Check-In, Tek-Com, Tek-Digicare, Tek-Door, Tek-Entry, Tek-Guard, Tek-Micro, Tek-MMARS, TekNIOS, Tek-Paging, Tek-Phone, Tek-Safe, Tek-Select, Tek-Sentry, Tek-Sound, Tek-Status, Tek-Trio and Tek-View are either registered trademarks or trademarks of TekTone® Sound & Signal Mfg., Inc. in the United States and/or other countries. All other trademarks are the property of their respective owners.

Tek-CARE®500 devices comply with Part 15 of the FCC Rules. Operation is subject to the following two conditions: (1) Devices may not cause harmful interference, and (2) devices must accept any interference received, including interference that may cause undesired operation.

TekTone Part #	FCC ID#
NC500SK	HCQ3B6SSR16, HCQ3B6UMXF
NC505	HCQ3B6SSR64
NC510	HCQ3B6FA403
NC511, NC512	HCQ3B6SSRL
SF501	HCQ3B6RTA
SF502	HCQ3B6RTX
SF505	HCQ3B6ESL
SF515	HCQ3B6SSF
SF520, SF525, SF526, SF527, SF528	HCQ3B6UMXF
SF529/A, SF530, SF531/A	HCQ3B6U1XFM

Table of Contents

System Operating Instructions	1
NC501 Master Station Computer Setup and Usage	1
The Tek-CARE®500 Operating Screen	1
Menu Bar	1
Online Indicator	1
Error Indicator	1
Night Mode Indicator	1
Demo Mode Indicator	1
Transmitter/Locator Indicator	1
Signal Indicator	1
RF Signal Strength Indicator	1
Battery Indicator	1
Events Monitor Button (F2)	2
Residents Button (F3)	2
Transmitters Button (F4)	2
Page Button (F5)	2
History Button (F6)	2
System Log Button (F7)	2
F8—Turn Night Mode On/Off	2
Silence Alarm Button (Ctrl+A)	2
Alt+X—Quit	2
Resident Menu	2
Assign/Unassign Transmitter	2
New Resident	2
Delete Resident	2
Residents Register (F3)	2
Transmitters Menu	7
Low Battery	7
Missing Transmitters	7
Lost Transmitters	7
Transmitters Register (F4)	7
Events Menu	10
Events Monitor (F2)	10
Events History (F6)	11
Paging Menu	12
Send Page (F5)	13
Paging Groups Register	13
Pagers Register	13
System Menu	14
Night Mode (F8)	14
Locators & Repeaters	14
Zones Register	16
Edit Proximity Map	17
System Log (F7)	17
System Operation History Log	19
Database (DB) Maintenance Log	19
Configure Menu	19
Tek-CARE®500 Options	19
Signal Interface Setup	19
Paging Interface Setup	21
Database Setup & Maintenance	21
Customize Sounds	23
Help Menu	23
Tek-CARE®500 Help	23
About Tek-CARE®500	23
Exit Menu	24
Important Terms	24
Device Operation	24

System Installation	26
Equipment Installation	26
System Components	26
Initial Programming	29
System Troubleshooting Guide	32
Appendix: Central Monitoring	33
Overview	33
Central Monitoring (CM) Server	33
Central Monitoring (CM) Config Tool	33
Starting Central Monitoring	34
Stopping Central Monitoring	36
Illustrations	
Figure 1—Tek-CARE®500 Operating Screen & Residents Register	3
Figure 2—Residents Register—Medical Information Tab	4
Figure 3—Residents Register—Contacts List Tab	4
Figure 4—Residents Register—Assigned Transmitters Tab—Transmitter Info sub-Tab .	4
Figure 5—Residents Register—Assigned Transmitters Tab—Programmable Timers sub-Tab .	5
Figure 6—Residents Register—Assigned Transmitters Tab—Paging Groups sub-Tab .	5
Figure 7—Residents Register—Assigned Transmitters Tab—Zones sub-Tab	5
Figure 7a—Residents Register—Notes Tab	6
Figure 8—Low Battery	6
Figure 9—Missing Transmitters	6
Figure 10—Lost Transmitters	6
Figure 11—Transmitters Register (F4)	8
Figure 12—Transmitters Register—Programmable Timers Tab	8
Figure 13—Transmitters Register—Battery Status Tab	8
Figure 14—Events History (F6)	11
Figure 15—Send Page (F5)	12
Figure 16—Paging Groups Register	12
Figure 17—Pagers Register	12
Figure 18—Night Mode (F8)	14
Figure 19—Zones Register	16
Figure 20—Edit Proximity Map	16
Figure 21—System Log (F7)	18
Figure 22—System Operation History Log	18
Figure 23—Database Maintenance Log	18
Figure 24—Tek-CARE®500 Options—Tek-CARE®500 Tab	20
Figure 25—Tek-CARE®500 Options—Passwords Tab	20
Figure 25a—Administrator and User Password Access	20
Figure 25b—Tek-CARE®500 Options—Advanced Tab	20
Figure 26—Signal Interface Setup	20
Figure 27—Paging Interface Setup	22
Figure 28—Database Setup & Maintenance—Database Tab	22
Figure 29—Database Setup & Maintenance—Maintenance Tab	22
Figure 30—Customize Sounds	22
Figure 31—PK510 Serial Cable Connection	26
Figure 32—NC501 Master Station Computer Connections	27
Figure 33—CM Server	35
Figure 34—List Devices	35
Figure 35—Device List	35
Figure 36—Event Details	35
Figure 37—Account Details	35
Figure 38—Configuration Details	35

System Operating Instructions

NC501 Master Station Computer Setup and Usage

Due to the critical nature of the Tek-CARE®500 reporting features, all power saving features on the master station computer and monitor have been disabled. TekTone® recommends that the computer be dedicated to Tek-CARE®500. Running additional applications on the computer diminishes the effectiveness of the system and may halt (lock up) the system. **Note: Perform the Database Clean-up function regularly to ensure proper system operation.** See *System Operating Instructions—Configure Menu—Database Setup & Maintenance—Maintenance Tab—Database Clean-up* for complete details.

The Tek-CARE®500 Operating Screen

This section provides a brief description of the various parts of the operating screen. The separate menu sections go into greater detail regarding specific functions. Refer to *Figure 1* for operating screen layout.

Menu Bar—To access the Tek-CARE®500 system's various menu functions, move the mouse (or other pointing device) over a menu bar item and then click. This displays the available menu items.

Online Indicator—This indicator has two states:

- Green indicates the system software is running.
- Clear (off) indicates an error has occurred that interferes with the software. (See *Error Indicator*.)

Error Indicator—This indicator has three states:

- Clear (off) indicates no errors.
- Red indicates a significant, system-wide error in system operation has occurred.
- Orange indicates an error has occurred that affects only part of the system.

When an error has occurred, use the *System Log Button* to access more information regarding the nature of the error.

Night Mode Indicator—This indicator has two states:

- Clear (off) indicates that Day Mode is active.
- Blue indicates that Night Mode is active. (See *System Operating Instructions—System Menu—Night Mode (F8)* for more information.)

Note: The transmitter/locator, signal, signal strength and battery indicators work together to provide data for a single signal occurrence.

Demo Mode Indicator—This indicator is displayed only when Tek-CARE®500 is operating in demo mode. In demo mode, the system has the same functionality as normal mode, but runs for just 2 hours, after which the Tek-CARE®500 program quits and must be restarted. If you have purchased a Tek-CARE®500 and it runs in demo mode, please contact TekTone®'s sales department at (800) 327-8466.

Transmitter/Locator Indicator—Displays the transmitter number and locator number of the last signal received. Locator numbers are shown only when applicable.

Signal Indicator—This indicator has four states:

- Blue indicates a supervisory signal.
- Red indicates an alarm signal.
- Green indicates a reset signal.
- Orange indicates a tamper signal.

RF Signal Strength Indicator—Shows the strength of the last signal received.

Battery Indicator—This indicator has two states:

- Green/High shows good battery condition.
- Red/Low shows a low battery condition. (See *System Operating Instructions—Transmitters Menu—Low Battery* for more information.)

Events Monitor Button (F2)—Click on button or press F2 to display a list of currently active system events. The following information is provided: Time, Category, Type, Device #, Device Type, Resident Name, Zones, Location, Paging Group, Device Description, Reset at Site, Date Cleared, Cleared By and Event #. (See *System Operating Instructions—Events Menu—Events Monitor (F2)* for more information.)

Residents Button (F3)—Click on button or press F3 to display the Residents Register. (See *System Operating Instructions—Resident Menu—Residents Register (F3)* for more information.)

Transmitters Button (F4)—Click on button or press F4 to display the Transmitters Register. (See *System Operating Instructions—Transmitters Menu—Transmitters Register (F4)* for more information.)

Page Button (F5)—Click on button or press F5 to send a page. (See *System Operating Instructions—Paging Menu—Send Page (F5)* for more information.)

History Button (F6)—Click on button or press F6 to display the Events History. The following information is provided: Time, Category, Type, Device #, Reset at Site, Date Cleared, Cleared By, Resident Name, Zones, Location, Paging Group, Device Type, Device Description and Event #. (See *System Operating Instructions—Events Menu—Events History (F6)* for more information.)

System Log Button (F7)—Click on button or press F7 to display the system log information—Date, Time and Event. (See *System Operating Instructions—System Menu—System Log (F7)* for more information.)

F8—Turn Night Mode On/Off—Press the F8 key to toggle Night Mode On/Off. (See *System Operating Instructions—System Menu—Night Mode (F8)* for more information.)

Silence Alarm Button (Ctrl+A)—Press (while a system event is active) to toggle between these two states:



—Alarm sounds are on



—Alarm sounds are off

Alt+X—Quit—Press the Alt+X key combination to quit the Tek-CARE®500 program.

Resident Menu

Assign/Unassign Transmitter—Prompts for a resident name and then displays the Transmitter Info tab in the Residents Register for that resident. (See *System Operating Instructions—Resident Menu—Residents Register (F3)* for more information.)

New Resident—Used to add a new resident to the system. (See *System Operating Instructions—Resident Menu—Residents Register (F3)* for more information.)

Delete Resident—Used to Delete a resident from the system.

Residents Register (F3)—This is the primary tool for handling resident information. To add a new resident, click the Add button and fill in all relevant information fields. (The various fields are discussed in detail below.) To edit an existing resident record, select the record and change the relevant information fields. When finished with all changes or additions to a specific resident record, click the Save button. Click the Add button to add another record, or click the Close button if finished.

The following searching and sorting functions are available in the Residents Register to facilitate the handling of resident information (refer to *Figure 1* for screen layout):

Search—Select the type of information to search in the drop-down category box. Enter the information to search for in the second field. Then click the *Go* button.

Show—Select an option from this drop-down box to show only one category of information.

Order By—Sort the displayed data by Resident Name, Building or Wing.



—Sort in ascending order, based on the *Order By* field.



—Sort in descending order, based on the *Order By* field.

The following features can be also accessed from the Residents Register:



—Displays first record in list.



—Displays prior record in list.



—Displays last record in list.



—Displays next record in list.

Add Button (Alt+A)—Add new residents to the system.

Cancel Edit Button (Alt+C)—Cancel all edits made to the displayed data (if Save button has not been clicked).

Delete Button (Alt+D)—Delete the selected residents from the system.

Save Button (Alt+V)—Save entered or edited information.

Refresh Button (Alt+H)—Refresh the displayed data to ensure information is current.

Close Button (Alt+L)—Close the Residents Register.



—Click on the print icon (or press Ctrl+P). To print only the selected record, click *Yes*, and the record will print immediately. To print all displayed records (filtered by any searches that have been invoked), click *No*, and a print preview screen will appear—click

Figure 1—Tek-CARE®500 Operating Screen & Residents Register

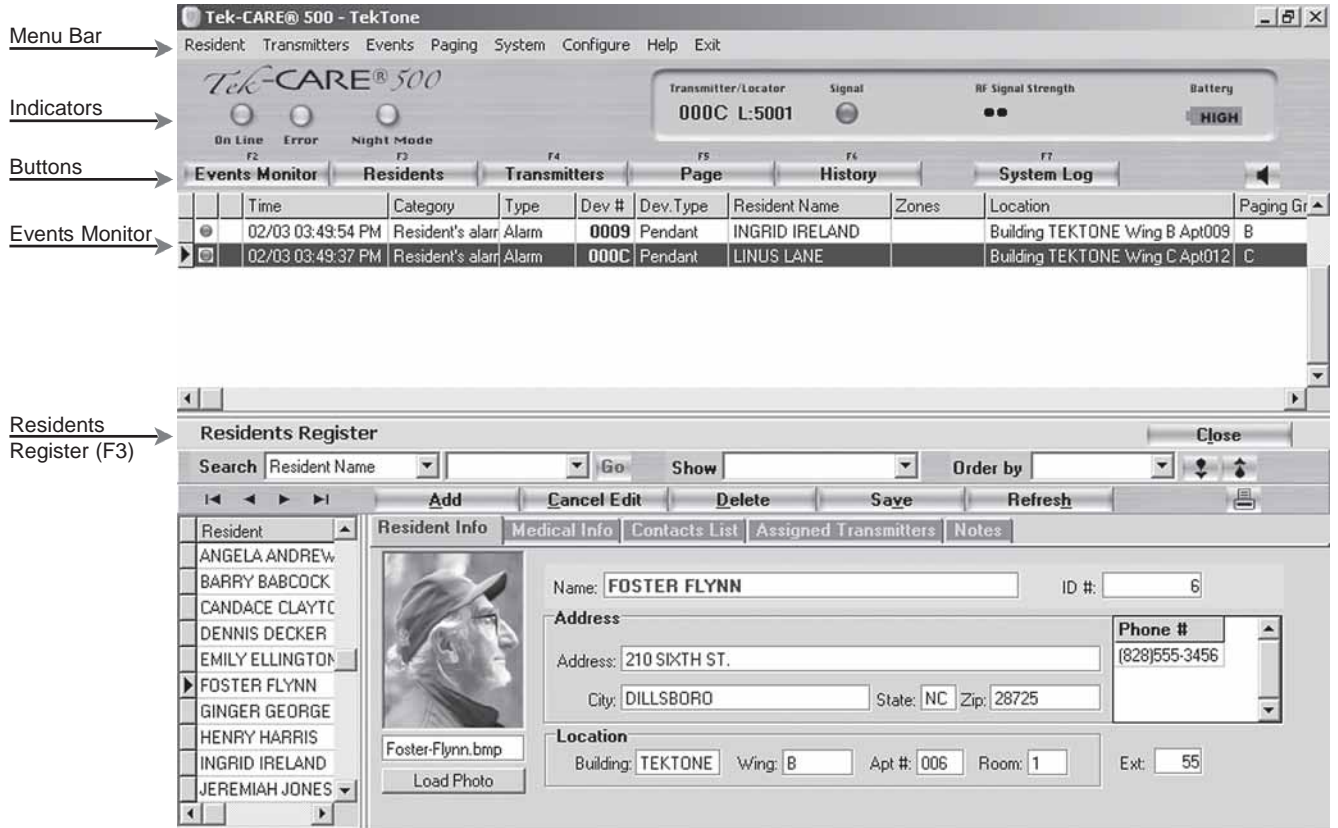

the printer setup button to select which pages to print; click the print button to print those pages.

Resident Info Tab—Provides a place to enter: name, ID #, address, city, state, zip, building, wing, floor, apartment number, phone number, and extension. (Only the first 17 characters of a name will be sent to pagers, although the name can be longer. Location information is required to assign zones.) Use the *Load Photo* button to select a resident photo from the local hard drive, using a browse function. Resident photos must be in bitmap format (.BMP), 100 pixels wide × 125 pixels high. Refer to *Figure 1* for screen layout.

Medical Information Tab—Provides a place to enter: physician, phone number, extension, hospital, allergies, medication, health history, instructions and insurance information. Refer to *Figure 2* for screen layout.

Contacts List Tab—Provides a place to enter: type (select from pull down menu), name, phone number, extension, comments and address. **Note:** Tek-CARE®500 shares information between records for “non-relative” contacts to allow system-wide update of common information. For example, updating a specific doctor’s phone number in one resident record changes it in all other resident records. “Relative” information is not shared between records. Refer to *Figure 3* for screen layout.

Assigned Transmitters Tab

Transmitter Info sub-Tab—Refer to *Figure 4* for screen layout. Provides a place to enter:

- Dev #—Assigns a transmitter to the selected resident. A Dev # must be entered in the Transmitters Register before it can be assigned.
- Status—Indicates the transmitter’s status. Status can be changed by the user if appropriate. (Lost, for example.)
- Date—This drop-down box next to the Status box allows a date to be associated with a particular status setting (if desired).

Figure 2—Residents Register—Medical Information Tab

Resident Info		Medical Info	Contacts List	Assigned Transmitters	Notes
Name: FOSTER FLYNN		ID #: 6			
Hospital: Community Hospital					
Physician	Phone #	Ext	Allergies	Medication	Health History
DR. WILMA WEBSTE	1-900-377-8225	444	Penicillin		

Figure 3—Residents Register—Contacts List Tab

Resident Info		Medical Info	Contacts List	Assigned Transmitters	Notes
Name: FOSTER FLYNN		ID #: 6			
Type	Name	Phone #	Ext	Comments	Address
Relatives	FRANCINE FLYNN	(828) 555-1111	1		
Hospital	COMMUNITY HOSPITAL	(828) 555-2222	2		

Figure 4—Residents Register—Assigned Transmitters Tab—Transmitter Info sub-Tab

Resident Info		Medical Info	Contacts List	Assigned Transmitters	Notes
Name: FOSTER FLYNN		ID #: 6			
Dev #	Dev.	Transmitter Info		Programmable Timers	Paging Groups
0006	Pendi	Dev #:	0006	Model:	SF501
0011	Call D	SINGLE-BUTTON WATER-RESISTANT PENDANT		Status:	normal operation
				Used as:	Call/Alarm device
				In Use <input checked="" type="checkbox"/>	

- Used As—This drop-down box determines the type of call the device sends. Options are: Call/Alarm Device, Check-In Device, Emergency Device, Repeater/Locator or Security Device. (Not all options are available for all devices.)
- In Use—This checkbox indicates the “use” status of a transmitter. To disable a transmitter, uncheck this box—signals from the device will not be processed, except battery signals which will be processed.

Programmable Timers sub-Tab—Refer to *Figure 5* for screen layout.

- Disable Supervision—Schedule a time period during which the system does not supervise signals from this transmitter. If the *supervision enabled* checkbox is not checked, reprogram the transmitter to be supervised (see *System Operating Instructions—Transmitters Menu—Transmitters Register—Device Info Tab*).
- Disable Alarm—Schedule a time period during which the system does not supervise alarms from this transmitter. (Available for security devices only, such as door/window egress transmitters.) Enable or disable all alarm schedules for a security device by checking or unchecking the *alarm enabled* checkbox in the upper right.
- Activity Check-In—Available for check-in devices only. Schedule a time period during which the system requires a button press (or motion if using a SF515 motion detector) from this transmitter. If the button is not pressed during the scheduled time period, a *Check Event* will appear in the event list approximately 5 minutes prior to the scheduled *End* time. Enable or disable all check-in schedules for a particular transmitter by checking or unchecking the *activity check-in enabled* checkbox in the upper right.

First, check the *Schd. Enabled* checkbox. Enter the start time in the *Begin* field and the end time in the *End* field. (Begin and End times must be at least 10

Figure 5—Residents Register—Assigned Transmitters Tab—Programmable Timers sub-Tab

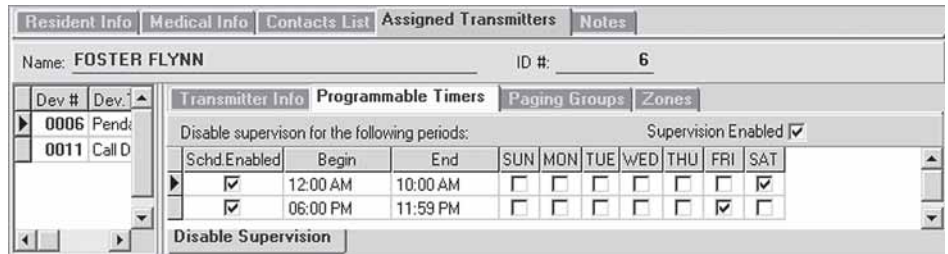

Figure 6—Residents Register—Assigned Transmitters Tab—Paging Groups sub-Tab

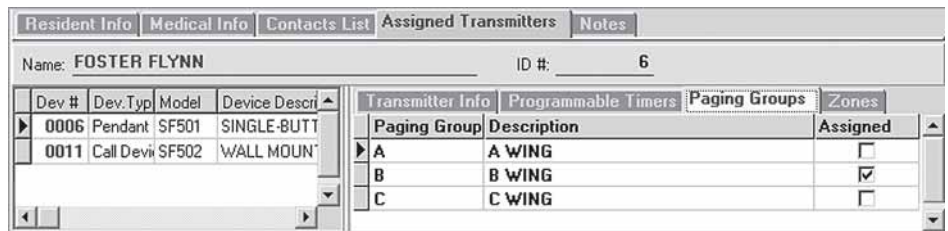
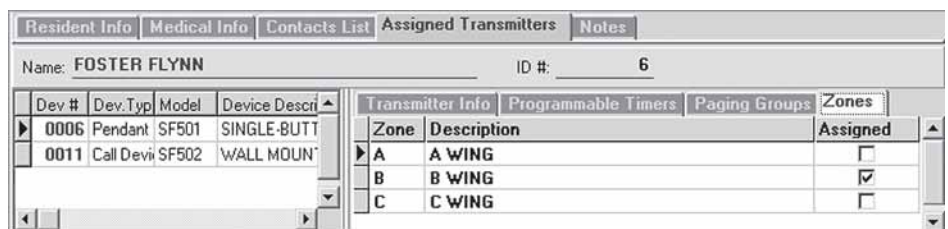

Figure 7—Residents Register—Assigned Transmitters Tab—Zones sub-Tab



minutes apart.) Check the boxes to select which days of the week this event is scheduled.

Note: A single time period cannot cross midnight into the next day; divide it into two time period entries. For example, create these two entries to create a scheduled time period of 6:00 PM Friday to 10:00 AM Saturday (as shown in *Figure 5*):

Begin—6:00 PM	End—11:59 PM	Day—Friday
Begin—12:00 AM	End—10:00 AM	Day—Saturday

Paging Groups sub-Tab—Assign the transmitter to one or more paging groups so that calls are paged in addition to normal call annunciation. (See *System Operating Instructions—Paging Menu* and *System Operating Instructions—System Menu—Night Mode (F8)* for more information.) Refer to *Figure 6* for screen layout.

Zones sub-Tab—Assign the transmitter to one or more zones, which are used as report filtering criteria for active and historical call data. All transmitters assigned to the same resident are automatically assigned to the same zones. Refer to *Figure 7* for screen layout. See *System Operating Instructions—System Menu—Zones Register* to create zones.

Notes Tab—Provides a place to enter additional notes, comments or requests. Refer to *Figure 7a* for screen layout.

Figure 7a—Residents Register—Notes Tab

Figure 8—Low Battery

Low Battery									Close
Dev #	Model	Device Description	Status	First Low Date	Exp.Shutdown Date	Last Changed Date	Resident Name	Location where mounted	
▶ 0007	SF501	SINGLE-BUTTON WATER-RE	LOW	08/22/2003	09/05/2003	08/20/2003	NATHAN NASH	LOCATION 2	

Figure 9—Missing Transmitters

Currently Missing Transmitters							Close
Dev #	Model	Missing Since	Device Description	Resident Name	Location where mounted		
▶ 0002	SF501	10/14/2003 11:24:39	SINGLE-BUTTON WATER-RESISTANT PENDANT	BARRY BABCOCK			
5005	NC512	10/03/2003 10:44:49	LOCATOR		MACHINE SHOP Building LOWER Wing B F		

Figure 10—Lost Transmitters

Lost Transmitters						Close
Dev #	Model	Lost Date	Device Description	Resident Name	Location where mounted	
▶ 0003	SF501	09/10/03	SINGLE-BUTTON WATER-RESISTANT	CANDACE CLAYTON		
0004	SF501	09/10/03	SINGLE-BUTTON WATER-RESISTANT	DENNIS DECKER		
727C	NC512	09/10/03	LOCATOR		R&D Building B2	

Transmitters Menu

Low Battery—Shows a list of transmitters that have low battery status, as well as information relevant to those transmitters. Refer to *Figure 8* for screen layout.

Missing Transmitters—Shows a list of transmitters from which the system is no longer receiving supervisory signals, as well as information relevant to those transmitters. Refer to *Figure 9* for screen layout.

Lost Transmitters—Shows a list of transmitters that have been classified as lost, as well as information relevant to those transmitters. Classify a transmitter as lost by changing the status in the Transmitters Register (F4) (see below). This status is used when a transmitter is still present in the building, but cannot be located. The system will not process call signals from lost transmitters, although it will continue to process battery status and tamper signals. Refer to *Figure 10* for screen layout.

Transmitters Register (F4)—This is the primary tool for modifying and accessing transmitter information. To add a new transmitter, click the Add button and fill in all relevant information fields. Fields designated with an asterisk (*) are settings programmed into the transmitter and cannot be changed without reprogramming the transmitter. (The various fields are discussed in detail below.) To edit an existing transmitter record, select the record and change the relevant information fields.

When finished with all changes or additions to a specific transmitter record, click the Save button. Then click the Program Transmitter button, if necessary (see *System Installation—Initial Programming—Programming Transmitters, Locators and Repeaters* for more information). Click the Add button to add another record, or click the Close button if finished.

The following searching and sorting functions are available in the Transmitters Register to facilitate the handling of transmitter information (refer to *Figure 11* for screen layout):

Search—Select the type of information to search in the drop-down category box. Enter the information to search for in the second field. Then click the Go button.

Show—Select an option from this drop-down box to show only one category of information.

Order By—Sort the displayed data by Device # or Model.



—Sort in ascending order, based on the *Order By* field.



—Sort in descending order, based on the *Order By* field.

The following features can also be accessed from the *Transmitters Register*:



—Displays first record in list.



—Displays prior record in list.



—Displays last record in list.



—Displays next record in list.

Add Button (Alt+A)—Add new transmitters to the system.

Cancel Edit Button (Alt+C)—Cancel all edits made to the displayed data (if Save button has not been clicked).

Save Button (Alt+V)—Save entered or edited information.

Refresh Button (Alt+H)—Refresh the displayed data to ensure information is current.

Close Button (Alt+L)—Closes the Transmitters Register.



—Click on the print icon (or press Ctrl+P). To print only the selected record, click *Yes*, and the record will print immediately. To print all displayed records (filtered by any searches that have been invoked), click *No*, and a print preview screen will appear—click the printer setup button to select which pages to print; click the print button to print those pages.

Figure 11—Transmitters Register (F4)

Transmitters Register

Time	Category	Type	Dev #	Dev.Type	Resident Name	Zones	Location	Paging Group
11/10 01:08:08 PM	Resident's alarr	Alarm	0012	Call Device	KAREN KANE		Building TEKTONE Wing C Floor 1 #:011	C
11/10 01:00:41 PM	Resident's alarr	Alarm	0006	Pendant	FOSTER FLYNN	B	Building TEKTONE Wing B Floor 1 #:006	B
11/10 01:00:01 PM	Resident's alarr	Alarm	0003	Pendant	CANDACE CLAYTON		Building TEKTONE Wing 1 Floor 1 #:003	A

Transmitters Register

Search Transmitter Dev # Go Show Order by

Device Info Programmable Timers Battery Status Zones Paging Groups

Dev # 000B * Model: SF501 In Use Supervised *

SINGLE-BUTTON WATER-RESISTANT PENDANT WITH L/

Status: normal operation

Supervision Interval: 150 sec *

Sup.Timeout (minutes): 30

Used as: Call/Alarm device

* The transmitter must be reprogrammed

Assigned to Resident 11 KAREN KANE

Program Transmitter

Device Info Tab—Location

Device Info Programmable Timers Battery Status Zones Paging Groups

Dev # 0011 * Model: SF502 In Use Supervised *

WALL MOUNTED TRANSMITTER

Status: normal operation

Supervision Interval: 12.5 min *

Sup.Timeout (minutes): 60

Used as: Call/Alarm device

* The transmitter must be reprogrammed

Location

Descr:

Building: Wing: Floor: Apt #:

Program Transmitter

Figure 12—
Transmitters Register—
Programmable Timers Tab

Device Info Programmable Timers Battery Status Zones Paging Groups

Dev #: 0006 Model: SF501 SINGLE-BUTTON WATER-RESISTANT PENDANT WITH LATC

Disable Supervision

Disable supervision for the following periods: Supervision Enabled

Sched.Enabled	Begin	End	SUN	MON	TUE	WED	THU	FRI	SAT
<input checked="" type="checkbox"/>	12:00 AM	10:00 AM	<input type="checkbox"/>	<input type="checkbox"/>	<input type="checkbox"/>	<input type="checkbox"/>	<input type="checkbox"/>	<input type="checkbox"/>	<input checked="" type="checkbox"/>
<input checked="" type="checkbox"/>	06:00 PM	11:59 PM	<input type="checkbox"/>	<input type="checkbox"/>	<input type="checkbox"/>	<input type="checkbox"/>	<input type="checkbox"/>	<input checked="" type="checkbox"/>	<input type="checkbox"/>

Figure 13—
Transmitters Register—
Battery Status Tab

Device Info Programmable Timers Battery Status Zones Paging Groups

Dev #: 0006 Model: SF501 SINGLE-BUTTON WATER-RESISTANT PENDANT WITH LATC

Battery Status: HIGH Last Changed Date:

Date when first low:

Expected Failure Date:

Device Info Tab—Refer to *Figure 11* for screen layout. Provides a place to enter Dev # and Model #, plus:

Status—Indicates the transmitter’s current status, which can be changed to reflect a different status if appropriate. Drop-down box choices are: normal operation, lost, missing, tampered, damaged, or in program/test mode.

Date—Located next to Status, this box allows a date to be associated with a particular status setting.

Used As—Select from the following choices in this drop-down box (not all options are available for all devices): Call/Alarm Device, Check-In Device, Emergency Device, Repeater/Locator or Security Device.

In Use—To disable a transmitter, uncheck this box. If unchecked, signals from this device will not be processed, although battery signals will be processed.

Supervised—Use this checkbox to indicate whether a transmitter is supervised (active) or unsupervised (inactive). Level of supervision is entirely dependent on system size and settings.

Supervision Interval—Determines how often the transmitter sends a signal to satisfy the Supervision Timeout function. The following minimum Supervision Interval settings are suggested (exceeding these recommendations increases the potential for missed alarm signals):

- Fewer than 200 transmitters:
 - SF501 Single-Button Call Transmitter—60 seconds (1 minute)
 - All other devices—5 minutes
- 200 to 1500 transmitters—5 minutes

Supervision Timeout (minutes)—Determines how long the system will wait without receiving a supervision signal before generating a supervision alarm. This setting is the maximum period of time that a transmitter can be out of communication with the system and not generate an alarm. (Not all supervision intervals are available for every transmitter type.) The following Supervision Interval and Supervision Timeout settings are recommended; the potential for missed alarm signals is increased if these recommendations are not followed. For systems that exceed 1000 devices, please call TekTone® Technical Support at (800) 332-6608.

Total Number of Devices	Device Type	Supervision Interval	Supervision Timeout
1–200	pendant	1 minute	60 minutes
1–200	wall mounted*	5 minutes	240 minutes
1–200		12.5 minutes	600 minutes
201–1000	pendant	5 minutes	240 minutes
201–1000	wall mounted*	5 minutes	240 minutes
201–1000		12.5 minutes	600 minutes
All wall-mounted AC powered devices**		60 minutes	1440 minutes

* *The Supervision Interval and Supervision Timeout values provided are typical values for systems of various sizes. These values are intended to provide the highest degree of supervision available without introducing a high risk of spurious missing-transmitter indications. Specific results will vary depending upon site conditions that affect the transmission and reception of RF signals.*

** *Options vary among wall-mounted devices.*

Assigned to—Displays name of resident or staff member to whom this transmitter is assigned (portable transmitters only). Double-click on the name to view that individual’s Residents Register information.

Location—Displays the location of permanently mounted transmitters. An entry is required in this field if zones will be assigned.

Program Transmitter—After a transmitter's information is entered, connect it to the NC510 Receiver for programming. See *System Installation—Initial Programming—Programming Transmitters, Locators and Repeaters* for more information. Fields denoted with an asterisk (*) are programmed into the device and cannot be changed without reprogramming the device. All other fields are editable.

Programmable Timers Tab—Refer to *Figure 12* for screen layout.

Disable Supervision—Schedule a time period during which the system does not supervise signals from this transmitter. If the *supervision enabled* checkbox is not checked, reprogram the transmitter to be supervised (see *System Operating Instructions—Transmitters Menu—Transmitters Register—Device Info Tab*).

Disable Alarm—Schedule a time period during which the system does not supervise alarms from this transmitter. (Available for security devices only, such as door/window egress transmitters.) Enable or disable all alarm schedules for a security device by checking or unchecking the *alarm enabled* checkbox in the upper right.

Activity Check-In—Available for check-in devices only. Schedule a time period during which the system requires a button press (or motion if using a SF515 motion detector) from this transmitter. If the button is not pressed during the scheduled time period, a *Check Event* will appear in the event list approximately 5 minutes prior to the scheduled *End* time. Enable or disable all check-in schedules for a particular transmitter by checking or unchecking the *activity check-in enabled* checkbox in the upper right.

First, check the *Schd. Enabled* checkbox. Enter the start time in the *Begin* field and the end time in the *End* field. (Begin and End times must be at least 10 minutes apart.) Use the checkboxes to select which days of the week this event is scheduled.

Note: A single time period cannot cross midnight into the next day; divide it into two time period entries. For example, create these two entries to create a scheduled time period of 6:00 PM Friday to 10:00 AM Saturday (as shown in *Figure 12*):

Begin—6:00 PM	End—11:59 PM	Day—Friday
Begin—12:00 AM	End—10:00 AM	Day—Saturday

Battery Status Tab—Shows the transmitter's current battery status and includes these fields to document battery status: Date when first low, Last Changed Date and Expected Failure Date. Refer to *Figure 13* for screen layout.

Zones Tab—Assign the transmitter to one or more zones, which are used as report filtering criteria for active and historical call data. All transmitters assigned to the same resident are automatically assigned to the same zones. See *System Operating Instructions—System Menu—Zones Register* to create zones.

Paging Groups Tab—Assign the transmitter to one or more paging groups so that calls are paged in addition to normal call annunciation. (See *System Operating Instructions—Paging Menu* and *System Operating Instructions—System Menu—Night Mode (F8)* for more information.)

Events Menu

Events Monitor (F2)—This is the core operational screen of the Tek-CARE®500 system, and displays all currently active events. The following information is provided: Time, Category, Type, Device #, Device Type, Resident Name, Zones, Location, Paging Group, Device Description, Reset at Site, Date Cleared, Cleared By and Event #. Refer to *Figure 1* for screen layout.

Right-click on an event to access these functions:

Clear/ACK (acknowledge) Event (Ctrl+C)—Resets call and removes it from the list. (Calls placed from SF501 Single Button Call Transmitters, SF527/SF337C Emergency Switch assemblies and SF528/SF340B Emergency Switch Assemblies cannot be reset at the Tek-CARE®500 master station computer; they must be reset in person.)

Silence Alarm (Ctrl+A)—Turn alarm sounds off. (Emergency calls cannot be silenced.)

Proximity Map (Ctrl+M)—Display the proximity map, highlighting the selected device or the locator in the general vicinity of the calling pendant transmitter.

Resident Info (Ctrl+R)—Display resident information.

Transmitter Info (Ctrl+T)—Display transmitter information.

Mark as Lost (Ctrl+L)—Mark the selected transmitter as lost (see *System Operating Instructions—Transmitters Menu—Lost Transmitters* and *System Operating Instructions—Transmitters Menu—Transmitters Register (F4)* for more information).

Events History (F6)—This shows a list of the events that have been cleared from the Events Monitor. The following information is provided: Time, Category, Type, Device #, Reset at Site, Date Cleared, Cleared By, Resident Name, Zones, Location, Paging Group, Device Type, Device Description and Event #. Refer to *Figure 14* for screen layout.

Right-click on an event to access these functions:

Resident Info (Ctrl+R)—Display resident information.

Transmitter Info (Ctrl+T)—Display transmitter information.

These search tools are provided to facilitate viewing the Events History:

Last xx Hours—Use this drop-down box to show only events from the last 24, 12, 6, 3 or 1 hours.

Filter Menu—Use this drop-down box to show only events in one of these categories: Show All, Emergency, Resident Alarm, Security Alarm, Inactivity Alarm, Supervision Alarm, Tamper Alarm or Missing Alarm.

Between Date and Time—Use these four fields to show only events that occurred in a specific period of date and time.

Search—Select the type of information to search in the drop-down category box. Enter the information to search for in the second field. Then click the *Find* button.

Figure 14—Events History (F6)

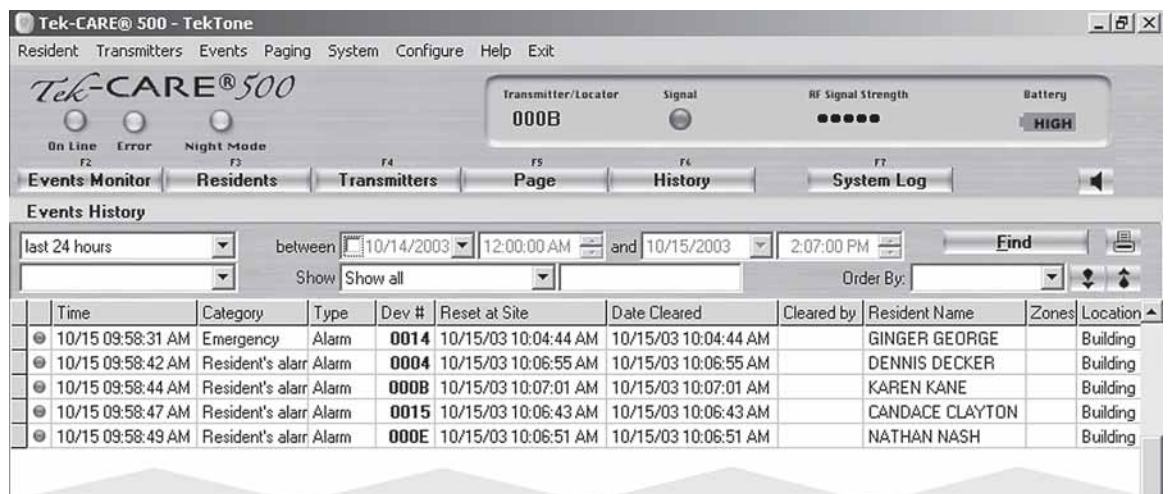

Order By—Sort the displayed data by Event Date, Device #–Time, Priority–Time, Reset at Site or Date Cleared.



—Sort in ascending order, based on the *Order By* field.



—Sort in descending order, based on the *Order By* field.



—Click on the print icon (or press Ctrl+P). A print preview screen will appear—click the printer setup button to select which pages to print; click the print button to print those pages.

Paging Menu

Paging is an ancillary method of call annunciation, and is not intended to replace the primary annunciation provided by the NC501 Master Station Computer. The Tek-CARE®500 system does not monitor pager battery levels or RF signal strength to the pagers, and the pagers are not supervised.

Figure 15—Send Page (F5)

Figure 16—Paging Groups Register

Paging Group	Description
A	A WING
B	B WING
C	C WING

Figure 17—Pagers Register

Pager ID	Name	Assigned
400	SARAH SMITH, RN	<input checked="" type="checkbox"/>
401	TIMOTHY THOMAS, LPN	<input type="checkbox"/>
402	URSULA UNGER, LPN	<input type="checkbox"/>
403	DR. VICTOR VANCE	<input type="checkbox"/>
404	DR. WILMA WEBSTER	<input type="checkbox"/>

Tek-CARE®500 supports two modes of paging: Day Mode and Night Mode. In Day Mode, pocket paging may be configured with multiple paging groups, so that only relevant pages are sent to each staff member. In Night Mode, all pages are sent to the default paging group—especially useful during hours when staff is reduced. (See *System Operating Instructions—System Menu—Night Mode (F8)* for more information.)

An automatic page message includes the time, resident, and location information, along with an initial single-letter code that indicates the event type. Event type codes are:

A = Alarm	E = Emergency	I = Inactivity	M = Missing
R = Reset	S = Security	T = Tamper	

Send Page (F5)—Send a manual page using the Send Page window, which provides these fields (refer to *Figure 15* for screen layout):

Name—Name of staff member carrying pager.

Pager ID—Pager ID number (3-digit cap code).

Paging Group—Paging group name.

Message—Text message to send to the selected pager(s).

Priority—(Priority settings are restricted to the paging system’s acceptable inputs.)

A—Urgent	B—High	C—Medium	D—Low
----------	--------	----------	-------

Enter the page recipient in either the Name, the Pager ID or the Paging Group field. Complete the Message and Priority fields, and then click the Send button to send the manual page. The Send Page window will show the send status. After the page is sent, click the Close button to close the window.

Paging Groups Register—Create paging groups so that several pagers can be paged simultaneously manually or in Day Mode. The following features can be accessed from the Paging Groups Register (refer to *Figure 16* for screen layout):



—Displays first record in list.



—Displays prior record in list.



—Displays last record in list.



—Displays next record in list.

Add Button (Alt+A)—Add a new paging group to the system.

Cancel Edit Button (Alt+C)—Cancel all edits made to the displayed data (if Save button has not been clicked).

Delete Button (Alt+D)—Delete the selected paging group from the system.

Save Button (Alt+V)—Save entered or edited information.

Refresh Button (Alt+H)—Refresh the displayed data to ensure information is current.

Close Button (Alt+L)—Close the Paging Groups Register.



—Click on the print icon (or press Ctrl+P) to print the Paging Groups list.

Pagers Register—Enter pagers into the system and assign them to paging groups. Provides a place to enter Pager ID (3-digit cap code) and staff member Name. The following searching and sorting functions are available in the Pagers Register to facilitate the handling of pager information (refer to *Figure 17* for screen layout):

Select the type of information to search in the drop-down category box. Enter the information to search for in the second field. Then click the *Go* button.

Show—Select an option from this drop-down box to show only one category of information.

Order By—Sort the displayed data by Pager ID or Name.



—Sort in ascending order, based on the *Order By* field.



—Sort in descending order, based on the *Order By* field.

The following features can also be accessed from the Pagers Register:



—Displays first record in list.



—Displays prior record in list.



—Displays last record in list.



—Displays next record in list.

Add Button (Alt+A)—Add a new pager to the system.

Cancel Edit Button (Alt+C)—Cancel all edits made to the displayed data (if Save button has not been clicked).

Delete Button (Alt+D)—Delete the selected pager from the system.

Save Button (Alt+V)—Save entered or edited information.

Refresh Button (Alt+H)—Refresh the displayed data to ensure information is current.

Close Button (Alt+L)—Close the Paging Register.



—Click on the print icon (or press Ctrl+P) to print the Pager list.

System Menu

Night Mode (F8)—This menu option opens the Tek-CARE®500 Options window with the Night Mode Setting tab selected. Refer to *Figure 18* for screen layout.

Tek-CARE®500 supports two modes of paging: Day Mode and Night Mode. In Day Mode, pocket paging may be configured with multiple paging groups, so that only relevant pages are sent to each staff member. In Night Mode, all pages are sent to the default paging group—especially useful during hours when staff is reduced. (See *System Operating Instructions—Configure Menu—Paging Interface Setup* to assign the default paging group.)

To manually enable Night Mode, click the Turn Night Mode On button. To automatically enable Night Mode, check the Enable Automatic Night Mode checkbox, enter the start time in the *Begin* field, the end time in the *End* field, and then click the Set button. Click the Close button to close the window.

Locators & Repeaters—This is an additional tool for handling locator and repeater information; all options are also available in the Transmitters Register. The following functions are available to facilitate the handling of locators and repeaters information:



—Displays first record in list.



—Displays prior record in list.



—Displays last record in list.



—Displays next record in list.

Add Button (Alt+A)—Add a new locator or repeater to the system.

Figure 18—Night Mode (F8)

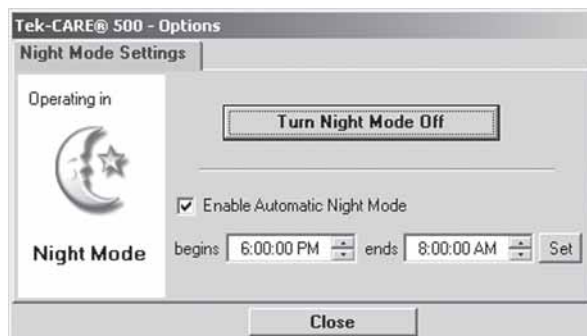
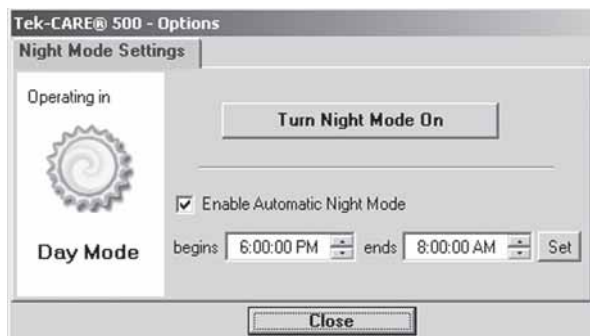

Cancel Edit Button (Alt+C)—Cancel all edits made to the displayed data (if Save button has not been clicked).

Save Button (Alt+V)—Save entered or edited information.

Refresh Button (Alt+H)—Refresh the displayed data to ensure information is current.

Close Button (Alt+L)—Close the Locators & Repeaters Register.



—Click on the print icon (or press Ctrl+P). To print only the selected record, click *Yes*, and the record will print immediately. To print all displayed records (filtered by any searches that have been invoked), click *No*, and a print preview screen will appear—click the printer setup button to select which pages to print; click the print button to print those pages.

Device Info Tab—Provides a place to enter Dev # and Model #, plus:

Status—Indicates the transmitter's current status, which can be changed to reflect a different status if appropriate. Drop-down box choices are: normal operation, lost, missing, tampered, damaged, or in program/test mode.

Date—Located next to Status, this box allows a date to be associated with a particular status setting.

Used As—The only choice in this drop-down box is: Repeater/Locator.

In Use—To disable a transmitter, uncheck this box. If unchecked, signals from this device will not be processed, although battery signals will be processed.

Supervised—Use this checkbox to indicate whether a transmitter is supervised (active) or unsupervised (inactive). Level of supervision is entirely dependent on system size and settings.

Supervision Interval—Determines how often the transmitter sends a signal to satisfy the Supervision Timeout function. The following minimum interval settings are suggested (exceeding these recommendations increases the potential for missed alarm signals):

- Fewer than 200 transmitters:
 - SF501 Single-Button Call Transmitter—60 seconds (1 minute)
 - All other devices—5 minutes
- 200 to 1500 transmitters—5 minutes

Supervision Timeout (minutes)—Determines how long the system will wait without receiving a supervision signal before generating a supervision alarm. This setting is the maximum period of time that a transmitter can be out of communication with the system and not generate an alarm. (Not all supervision intervals are available for every transmitter type.) The following Supervision Interval and Supervision Timeout settings are recommended; the potential for missed alarm signals is increased if these recommendations are not followed. For systems that exceed 1000 devices, please call TekTone® Technical Support at (800) 332-6608.

Total Number of Devices	Device Type	Supervision Interval	Supervision Timeout
1–200	pendant	1 minute	60 minutes
1–200	wall mounted*	5 minutes	240 minutes
1–200		12.5 minutes	600 minutes
201–1000	pendant	5 minutes	240 minutes
201–1000	wall mounted*	5 minutes	240 minutes
201–1000		12.5 minutes	600 minutes
All wall-mounted AC powered devices**		60 minutes	1440 minutes

* *The Supervision Interval and Supervision Timeout values provided are typical values for systems of various sizes. These values are intended to provide the highest degree of supervision available without introducing a high risk of spurious missing-transmitter indications. Specific results will vary depending upon site conditions that affect the transmission and reception of RF signals.*

** *Options vary among wall-mounted devices.*

Location—Displays the location of permanently mounted transmitters. An entry is required in this field if zones will be assigned.

Program Transmitter—After a locator or repeater’s information is entered, connect it to the NC510 Receiver for programming. See *System Installation—Initial Programming—Programming Transmitters, Locators and Repeaters* for more information. Fields denoted with an asterisk (*) are programmed into the device and cannot be changed without reprogramming the device. All other fields are editable.

Battery Status Tab—Shows the locator or repeater’s current battery status and includes these fields to document battery status: Date when first low, Last Changed Date and Expected Failure Date.

Zones Tab—Assign the locator or repeater to one or more zones, which are used as report filtering criteria for active and historical call data. All transmitters assigned to the same resident are automatically assigned to the same zones. See *System Operating Instructions—System Menu—Zones Register* to create zones.

Paging Groups Tab—Assign the locator or repeater to one or more paging groups so that calls are paged in addition to normal call annunciation. (See *System Operating Instructions—Paging Menu* and *System Operating Instructions—System Menu—Night Mode (F8)* for more information.)

Zones Register—Zones are used as report filtering criteria for active and historical call data. Define a zone as a geographical area of the facility, and then assign transmitters to the zone. All transmitters assigned to the same resident are automatically assigned to the same zones.

Figure 19—Zones Register

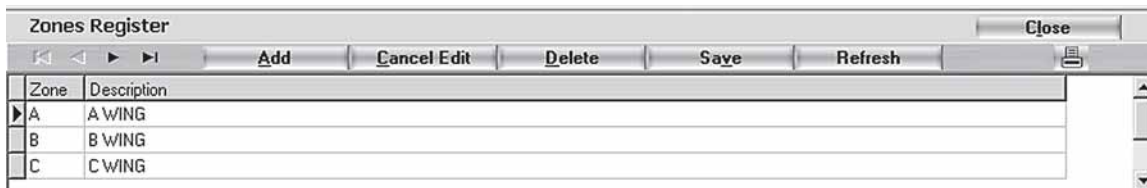
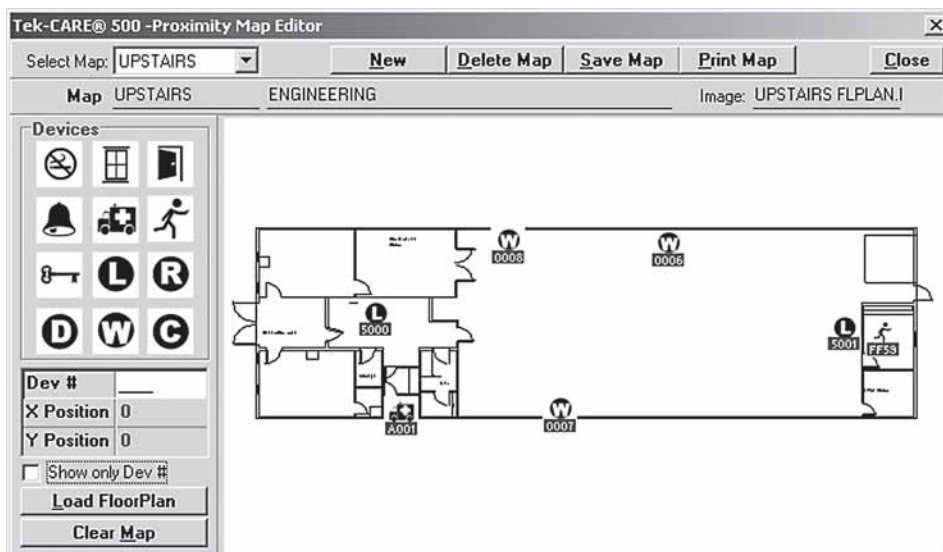

Figure 20—Edit Proximity Map



The following features can be accessed from the Zones Register (refer to *Figure 19* for screen layout):



—Displays first record in list.



—Displays prior record in list.



—Displays last record in list.



—Displays next record in list.

Add Button (Alt+A)—Add a new zone to the system.

Cancel Edit Button (Alt+C)—Cancel all edits made to the displayed data (if Save button has not been clicked).

Delete Button (Alt+D)—Delete the selected zone from the system.

Save Button (Alt+V)—Save entered or edited information.

Refresh Button (Alt+H)—Refresh the displayed data to ensure information is current.

Close Button (Alt+L)—Close the Zones Register.



—Click on the print icon (or press Ctrl+P) to print the zones list.

Edit Proximity Map—The proximity map is a visual representation of the facility's floor plan or layout. If properly set up, it displays the installed locations of fixed devices. If the system includes locators, the proximity map also displays the general locations of mobile transmitters, based on locator information. The following features can be accessed from Edit Proximity Map (refer to *Figure 20* for screen layout):

Select Map—Choose from the list of available proximity maps.

New—Generate a new proximity map. Then enter a map name and description, and click the *Load Floorplan* button to add a bitmap (.bmp) image of the facility's layout. The image must be 500 pixels wide × 300 pixels high (or a 5:3 ratio) to fit properly on the screen.

Delete Map—Deletes the presently selected proximity map.

Save Map—Save entered or edited information.

Print Map—Print the proximity map.

Close—Close the proximity map.

Devices—Place icons on the proximity map to represent fixed devices. Choose from these icons:



Smoke Detector



Window Open Sensor



Door Open Sensor



Alarm Device



Emergency Device



Motion Detector



Security Device



Locator



Repeater



Detector/Sensor



Wall Mounted Device



Check-In Device

Load Floorplan—Add a bitmap (.bmp) image of the facility's layout.

Clear Map—Removes all device icons from the map.

The map name and description fields display the selected map's information, and are data entry fields when creating a new map.

System Log (F7)—Displays the last 300 functional activities of the Tek-CARE®500 software. This log is provided as a troubleshooting tool for installers and factory personnel, and is

Figure 21—System Log (F7)

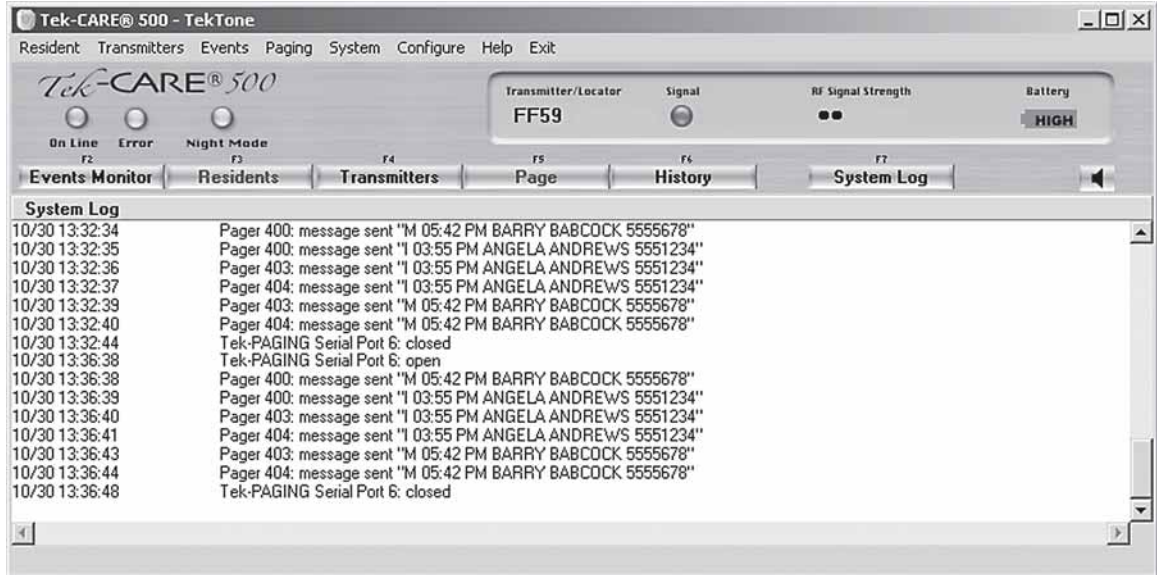

Figure 22—System Operation History Log

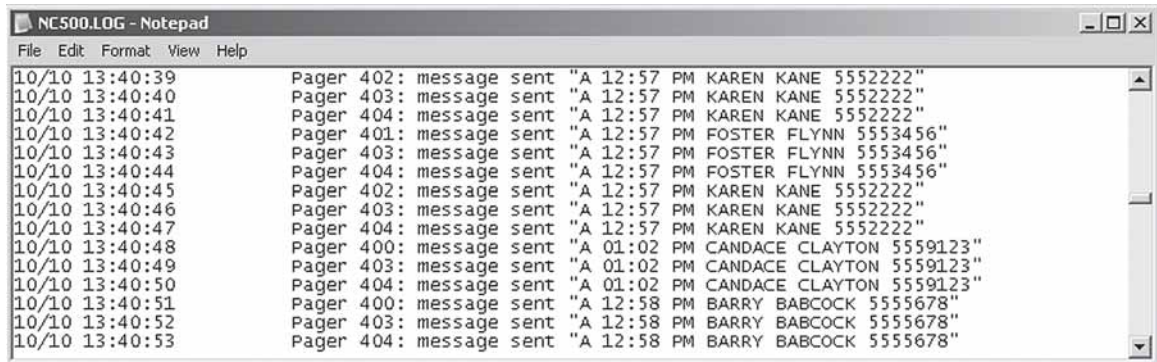
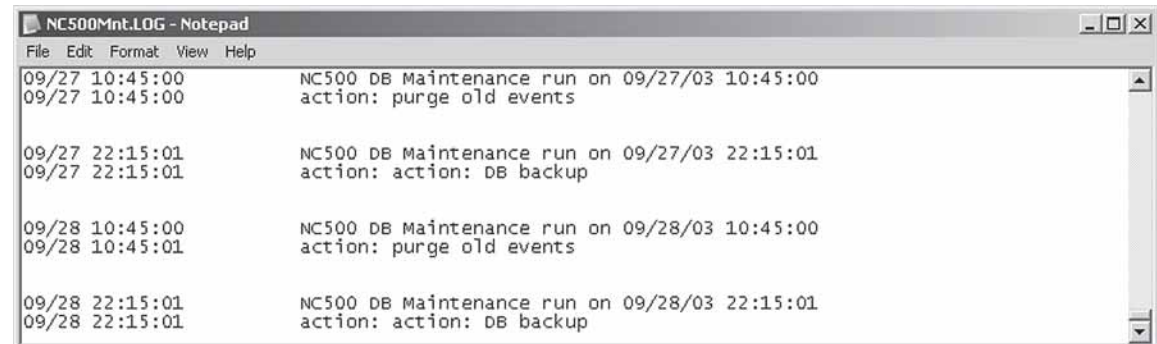

Figure 23—Database Maintenance Log



normally not used by facility staff. Data logging can be disabled in *Configuration Menu—Tek-CARE®500 Options*. Refer to *Figure 21* for screen layout.

System Operation History Log—Another troubleshooting log, this displays all functional activities of the Tek-CARE®500 software since installation, or since the log file was last deleted. This log is provided as a troubleshooting tool for installers and factory personnel, and is normally not used by facility staff. Data logging can be disabled in *Configuration Menu—Tek-CARE®500 Options*. Refer to *Figure 22* for screen layout.

Database Maintenance Log—Cumulatively records the functional activity of Tek-CARE®500's database maintenance. This log is provided as a troubleshooting tool for installers and factory personnel, and is normally not used by facility staff. Refer to *Figure 23* for screen layout.

Configure Menu

Tek-CARE®500 Options—This menu option displays the Tek-CARE®500 Options window with the Tek-CARE®500 tab selected. The following features are available:

Tek-CARE®500 Tab—Refer to *Figure 24* for screen layout.

Station ID—Factory setting is 1, and must not be changed. This setting is reserved for future development of multiple station applications.

Facility—Enter the facility's name here so that it is displayed in the Tek-CARE®500's top window bar and on all printed reports.

Password Protected Quit Program Checkbox—If this box is checked, a username and password must be entered to quit the Tek-CARE®500 software.

Save System Log Checkbox—If this box is checked, the system will maintain a log of system operation, as described in *System Menu—System Log (F7)* and *System Menu—System Operation History Log*.

Apply Changes Button—Implements changes made on this tab.

Night Mode Settings Tab—This tab's functions are described in *System Menu—Night Mode (F8)*.

Passwords Tab—Create the administrator-level password and/or the user-level password (maximum one of each type), and then click the Set Button. Refer to *Figure 25* for screen layout. The administrator password is required for higher level functions; the user-level password is used for day-to-day operations (refer to *Figure 25a* for password access levels). The system will request the appropriate password when required.

Advanced Tab—Used to adjust both the length of time before checking for missing transmitters and the time between checks for missing transmitters. **Use the default settings unless told otherwise by TekTone® staff** (usually for sites having more than 1000 transmitters). Restart the Tek-CARE®500 system to make the changes effective. Refer to *Figure 25b* for screen layout.

Signal Interface Setup—This menu option displays the I/O Interfaces window with the Signal Interface tab selected. This screen is used to set up the receivers that will be connected to the Tek-CARE®500 system. One receiver has been set up at the factory. The following features are available (refer to *Figure 26* for screen layout):

Add Button—Begin the process of adding a receiver.

Remove Button—Remove the selected receiver.

Apply/Install Button—Implement entered or edited information.

Cancel Button—Cancel all edits made to the displayed data (if Apply/Install button has not been clicked).

**Figure 24—Tek-CARE®500 Options—
Tek-CARE®500 Tab**



**Figure 25—Tek-CARE®500 Options—
Passwords Tab**



**Figure 25b—Tek-CARE®500 Options—
Advanced Tab**

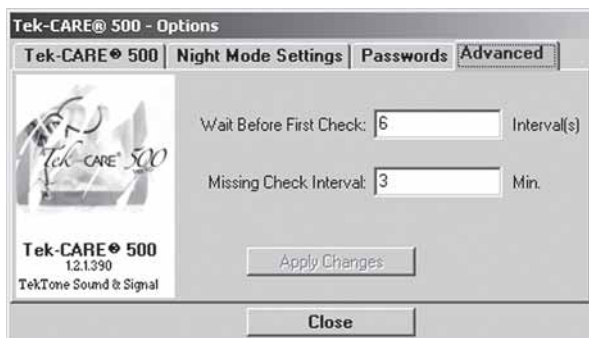

Figure 26—Signal Interface Setup

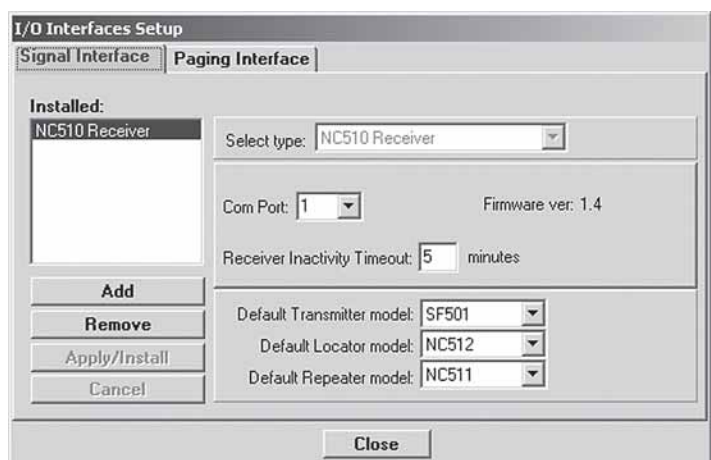

Figure 25a—Administrator and User Password Access—*items in gray do not require a password*

Action	Admin	User
Resident Menu		
Assign/Unassign Transmitter	yes	yes
Add New Resident	yes	yes
Delete Resident	yes	yes
Residents/Patients Register	yes	yes
Transmitters Menu		
Low Battery	yes	yes
Missing Transmitters	yes	yes
Lost Transmitters	yes	yes
Transmitters Register	yes	yes
Events Menu		
Events Monitor		
Events History		
Paging Menu		
Send Page	yes	yes
Paging Groups Register	yes	yes
Pagers Register	yes	yes
System Menu		
Night Mode (F8)	yes	yes
Locators & Repeaters	yes	yes
Zones	yes	yes
Edit Proximity Map	yes	—
System Log		
System Operation History Log		
DB Maintenance Log		

Action	Admin	User
Configure Menu		
Tek-CARE Options	yes	—
Signal Interface Setup	yes	—
Paging Interface Setup	yes	—
Database Setup & Maintenance	yes	—
Customize Sounds	yes	—
Help Menu		
Exit Menu	yes	—
Buttons		
Events Monitor (F2)		
Residents (F3)	yes	yes
Transmitters (F4)	yes	yes
Page (F5)	yes	yes
History (F6)		
System Log (F7)		
Silence Alarm (Ctrl+A)	yes	yes
Close	yes	yes
Right-Click Menu		
Clear Event (Ctrl+C)	yes	yes
Silence Alarm (Ctrl+A)	yes	yes
Proximity Map (Ctrl+M)		
Resident Info (Ctrl+R)	yes	yes
Transmitter Info (Ctrl+T)	yes	yes
Mark as Lost (Ctrl+L)	yes	yes

Select Type Drop-Down Box—Select from these available types of receivers: NC510 Receiver.

COM Port Drop-Down Box—Choose which system COM port the receiver is connected to.

Receiver Inactivity Timeout—Set how long the receiver is inactive before it generates an alarm message.

Transmitter model—Set the default transmitter model that is displayed in the Registers when creating new entries. Default setting is SF501.

Locator model—Set the default locator model that is displayed in the Registers when creating new entries. Default setting is NC512.

Repeater model—Set the default repeater model that is displayed in the Registers when creating new entries. Default setting is NC511.

Paging Interface Setup—This menu option displays the I/O Interfaces window with the Paging Interface tab selected. This screen is used to set up the paging transmitters that will be connected to the Tek-CARE®500 system. For more information, see *System Installation—Initial Programming—Paging Interface*. The following features are available (refer to *Figure 27* for screen layout):

Add Button—Begin the process of adding a paging transmitter.

Remove Button—Remove the selected paging transmitter.

Apply/Install Button—Implement entered or edited information.

Cancel Button—Cancel all edits made to the displayed data (if Apply/Install button has not been clicked).

Select Type Drop-Down Box—Select from these available types of paging transmitters: Tek-PAGING™.

COM Port Drop-Down Box—Choose which system COM port the paging transmitter is connected to.

Default Paging Group—Set the default paging group for Night Mode.

Re-page Interval—Set the frequency of pager transmissions for a given event.

Do not send RESET event to pagers—When checked, event/device resets are not sent to pagers.

Disable paging in DAY MODE operation—When checked, automatic paging is not available in Day Mode.

Enable Re-paging—When checked, a call that is not reset within the Re-page Interval will be resent to pagers. (Only calls made after re-paging is enabled will be re-paged. Calls made while the feature is disabled will not be re-paged after it is enabled.)

Send to Pager Drop-Down Box—Choose what information is sent to pagers: Resident Name and Phone #, or Resident Name and Building & Apt #. If total characters exceeds 36, the end of the resident's name will be cut off.

Database Setup & Maintenance—This menu option displays the Database Setup & Maintenance window with the Database tab selected. This screen is used to set up the schedule and options for maintaining the database. For more information, see *System Installation—Initial Programming—Set Up Database Maintenance Schedule*. The following features are available:

Database Tab—These settings are either preset or are set up with the initial installation and should only be changed by qualified personnel. Refer to *Figure 28* for screen layout.

File—The path to the database file. This cannot be changed.

Auto Display all records—When checked (default), the Residents Register and the Transmitters Register display all records when opened. When unchecked, the Registers display no records when opened—enter search criteria to show desired records.

Purge events older than __ months—Determines how long old events are retained and viewable. Entries beyond this time cannot be accessed via the Events History window.

Purge Schedule—Used to schedule maintenance options for purging the database of extraneous data. **In order to set up scheduled maintenance, set the password on the task page. This password must be the same as the password used to log on as administrator to the NC501 Master Station Computer. Factory default administrator logon is:**

User: tekcare500 Password: tektone

Automatic backup—Use to create a backup of the current database at a scheduled interval. Default setting is active.

Figure 27—Paging Interface Setup

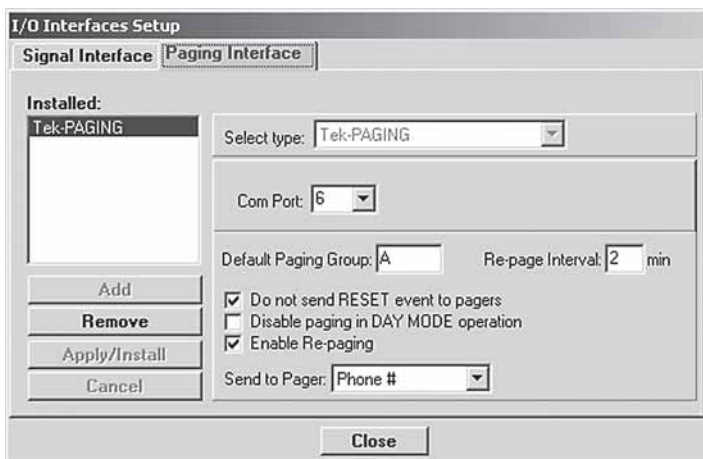

Figure 28—Database Setup & Maintenance—Database Tab

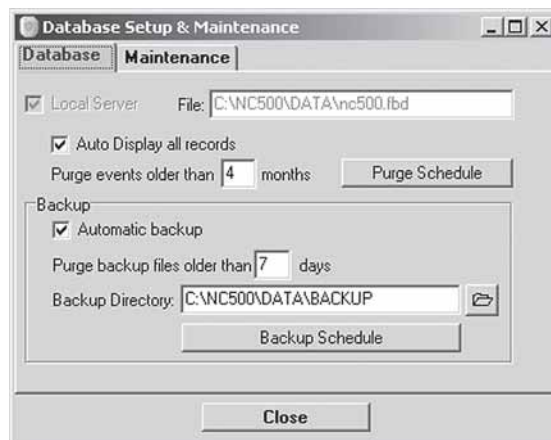

Figure 29—Database Setup & Maintenance—Maintenance Tab

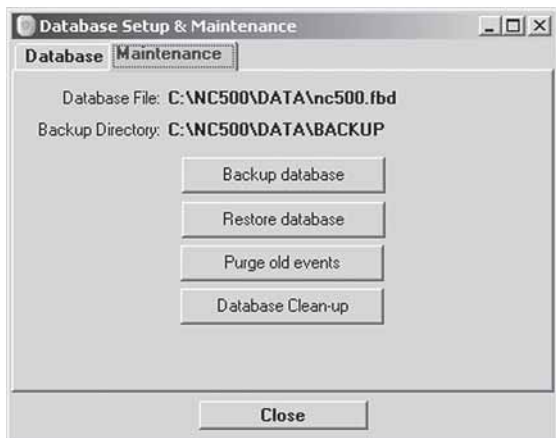
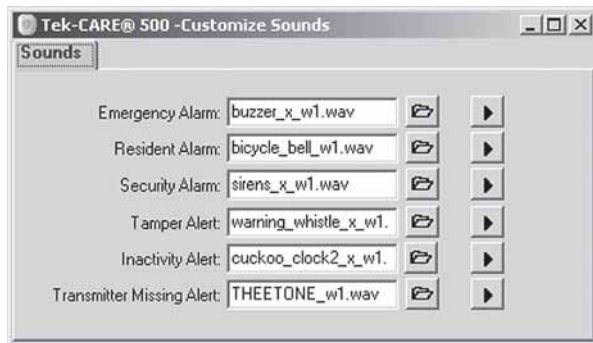

Figure 30—Customize Sounds



Purge backup files older than __ days—Determines how long backed up data will be retained and available for restoration.

Backup Directory—C:\TekCARE500\data\backup\ is the path to the backup files directory.

Backup Schedule—Used to schedule automatic backup of the database to C:\TekCARE500\data\backup\. TekTone® recommends copying the files from the backup directory to removable media (floppies or CD-Rs) on a regular schedule. **In order to set up scheduled database backup, set the password on the task page. This password must be the same as the password used to log on as administrator to the NC501 Master Station Computer. Factory default administrator logon is:**

User: tekcare500

Password: tektone

Maintenance Tab—Displays the current database file location and the path to the current backup directory. The following options are available (refer to *Figure 29* for screen layout):

Backup Database—Creates a manual backup of the current database to C:\TekCARE500\data\backup\. It is not necessary to create a manual backup if automatic backup has been set up in *Database Tab—Backup Schedule*. TekTone® recommends copying the files from the backup directory to removable media (floppies, USB flash drives or CD-Rs) on a regular schedule.

Restore Database—Deletes the current database and replaces it with a previous backup of the database. Choose from a list of valid backup files. This function causes the Tek-CARE®500 software to automatically shut down and restart. TekTone® recommends performing *Backup Database* immediately before *Restore Database*.

Purge Old Events—Manually deletes events older than the time specified in *Database Tab—Purge events older than __ months*. It is not necessary to manually purge old events if an automatic purge schedule has been set up in *Database Tab—Purge Schedule*.

Database Clean-up—Removes unnecessary, temporary information from the active database. It is recommended that this function be performed monthly to ensure efficient operation of the database. This function causes the Tek-CARE®500 software to automatically shut down and restart.

Customize Sounds—Use this menu option to customize which sound file is associated with each event type. Additional sounds have been included with the installation in the directory C:\TekCARE500\Sounds\. Custom sounds may also be added; they must be the .wav file type, under 200 kb file size, and placed in the directory C:\TekCARE500\Sounds\.

The following events have associated sound files: Emergency Alarm, Resident Alarm, Security Alarm, Tamper Alert, Inactivity Alert and Transmitter Missing Alert. Refer to *Figure 30* for screen layout.



Browse for a .wav sound file to associate with this event.



Play the .wav sound file associated with this event.

Help Menu

Tek-CARE®500 Help—An online version of the printed manual.

About Tek-CARE®500—Provides information about software version.

Exit Menu

Closes all interfaces and terminates the Tek-CARE®500 software application. No information will be displayed or logged when the software is not running. (The Alt+X key combination performs the same function.)

Important Terms

Damaged—The transmitter is not functioning, whether temporarily or permanently. This state is assigned by the user, and allows the system to ignore transmissions from this device. This transmitter's information will continue to be stored in the database.

Lost—The transmitter is still present in the building, but cannot be located. This state is assigned by the user; and allows the system to ignore transmissions from this device.

Missing—The system is not receiving transmitter supervisory signals. This state is assigned by the system.

Tampered—The transmitter has been tampered with. Typically indicates that case of transmitter has been opened. This state is assigned by the system.

Virgin Signal—A signal from a transmitter that hasn't been reproduced by a locator/repeater.

Device Operation

NC397 Alphanumeric Pocket Pager—Refer to the included owner's manual for operational information.

SF501 Single Button Call Transmitter—A water resistant transmitter suitable for use in showers and bathtubs. The SF501 includes a lightweight neck chain, which will separate to prevent choking if it is pulled tight.

Place a call—Press and hold the large button on the front of the transmitter for at least 1 second. The SF501 transmitter will transmit the call and its call-assurance LED will blink rapidly. Every 3 seconds until it is reset, the SF501 will resend the call signal and its call-assurance LED will blink.

Reset a call—Use a ballpoint pen or similar device to press the recessed black button on the back of the transmitter. The transmitter will send a reset signal to the system and its call-assurance LED will blink rapidly. Call cannot be reset at the Tek-CARE®500 master station computer; it must be reset in person.

SF502 Wall-Mounted Call Transmitter

Place a call—Press and hold the large button on the front of the transmitter for at least 1 second. The SF502 transmitter will transmit the call once only and its call-assurance LED will blink rapidly. To transmit the call continually, press and hold the button.

Reset a call—Reset the call at the Tek-CARE®500 master station computer as described in *System Operating Instructions—Events Menu—Events Monitor (F2)*.

SF527 Wireless Support Module with SF337C Waterproof Emergency Switch

SF528 Wireless Support Module with SF340B Emergency Switch (not waterproof)

SF531/A Wireless Emergency Station

Place a call—Push the red emergency switch down or pull the attached cord. The transmitter will transmit the call and its call-assurance LED will light.

Reset a call—Push the red emergency switch up. The transmitter will send a reset signal to the system and its call-assurance LED will go out. Call cannot be reset at the Tek-CARE®500 master station computer; it must be reset in person.

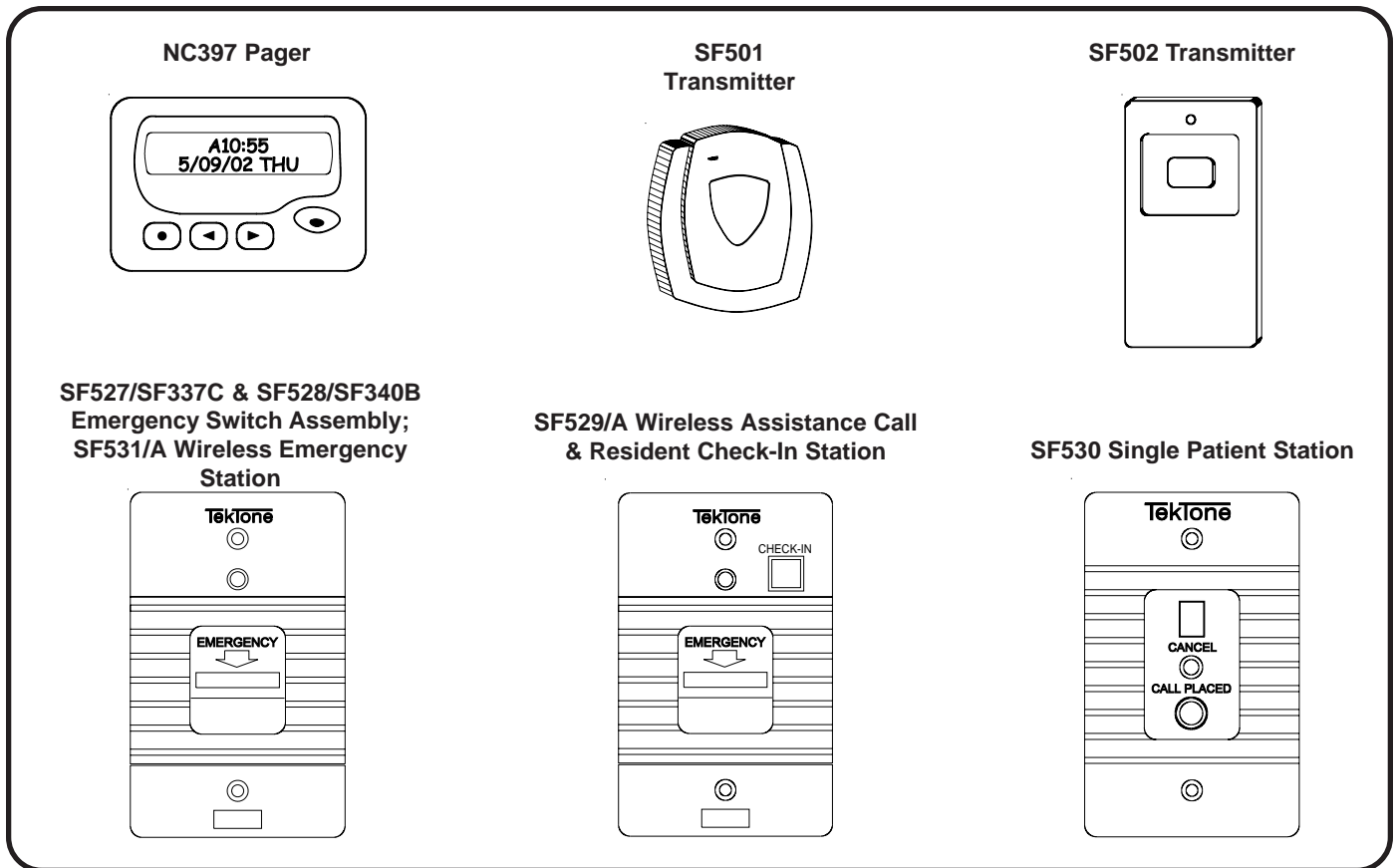

SF529/A Wireless Assistance Call & Resident Check-In Station

Place a call—Push the red emergency switch down or pull the attached cord. The transmitter will transmit the call and its call-assurance LED will light.

Reset a call—Push the red emergency switch up. The transmitter will send a reset signal to the system and its call-assurance LED will go out. Call cannot be reset at the Tek-CARE®500 master station computer; it must be reset in person.

Resident Check-In—Push the check-in button during the scheduled check-in time period.

SF530 Single Patient Station

Place a call—Push the call button at the end of the associated call cord. The transmitter will transmit the call and the call-assurance LED will light.

Reset a call—Push reset button on the patient station. The transmitter will send a reset signal to the system and the call-assurance LED will go out. Call cannot be reset at the Tek-CARE®500 master station computer; it must be reset in person.

System Installation

Equipment Installation

Ensure that a site survey has been done by a qualified TekTone® representative. This is a necessary step to correctly determine what equipment is necessary and where it should be located. A properly done site survey will also identify potential problem areas in a facility so that those issues may be addressed. **Note: The total number of transmitters must not exceed 1500.**

Connect system components according to *Figures 31 and 32*. System component descriptions are below.

System Components

TekTone®'s Tek-CARE®500 Wireless Emergency Call System consists of and/or supports the following equipment. Each unit is packaged with specific installation, programming and operating instructions. For more detailed information visit our website: www.tektone.net.

NC501 Master Station Computer—The core component of the Tek-CARE®500 system.

NC510 Receiver—Connected directly to the NC501 Master Station Computer, the receiver transfers information received from the transmitters in the field to the Tek-CARE®500 master station computer.

NC511 Repeater—Extends the transmission range of transmitters and locators. An optional IH511 weatherproof housing is available for indoor or outdoor use with a backup battery.

NC512 Locator—Use to determine the approximate location of roaming transmitters. Not recommended for use in multi-story buildings. An optional IH511 weatherproof housing is available for indoor or outdoor use with a backup battery.

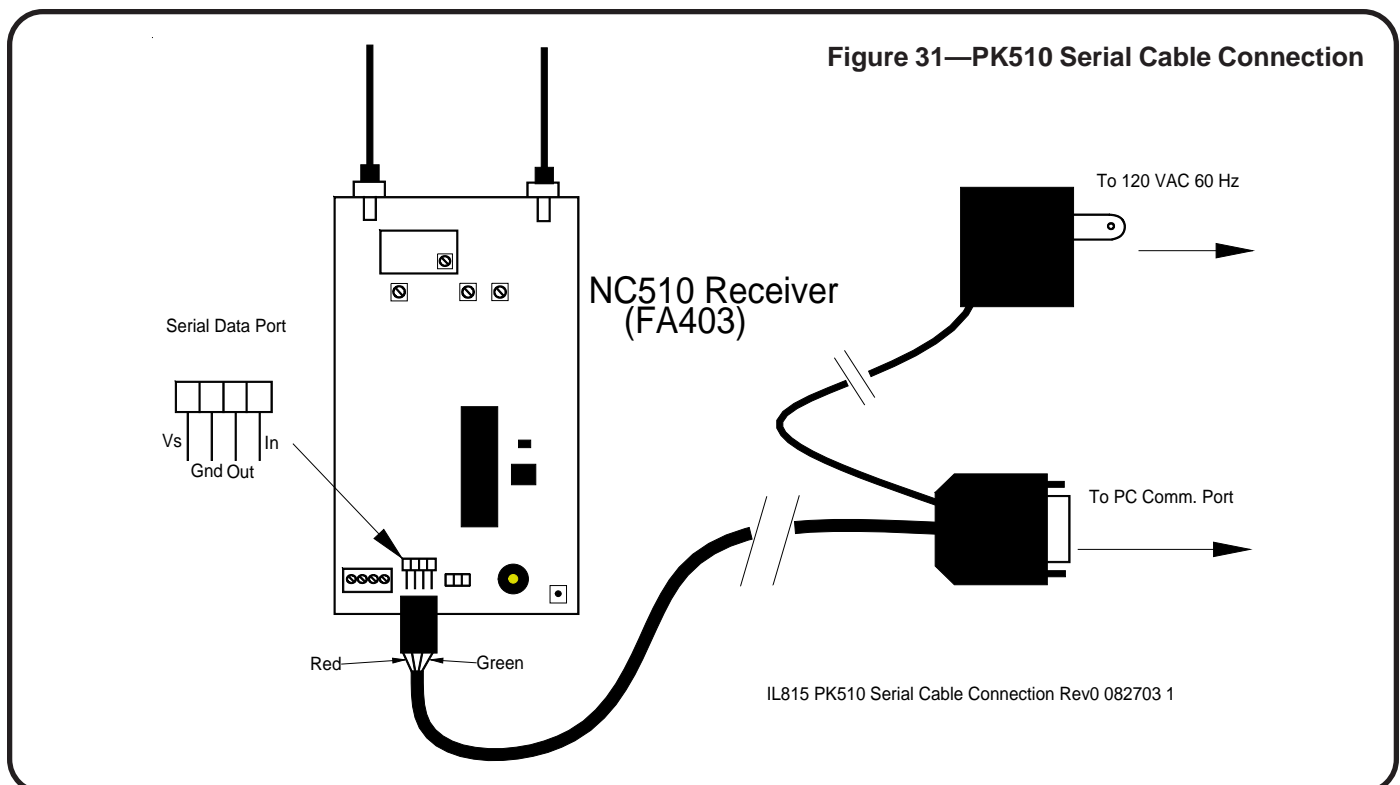
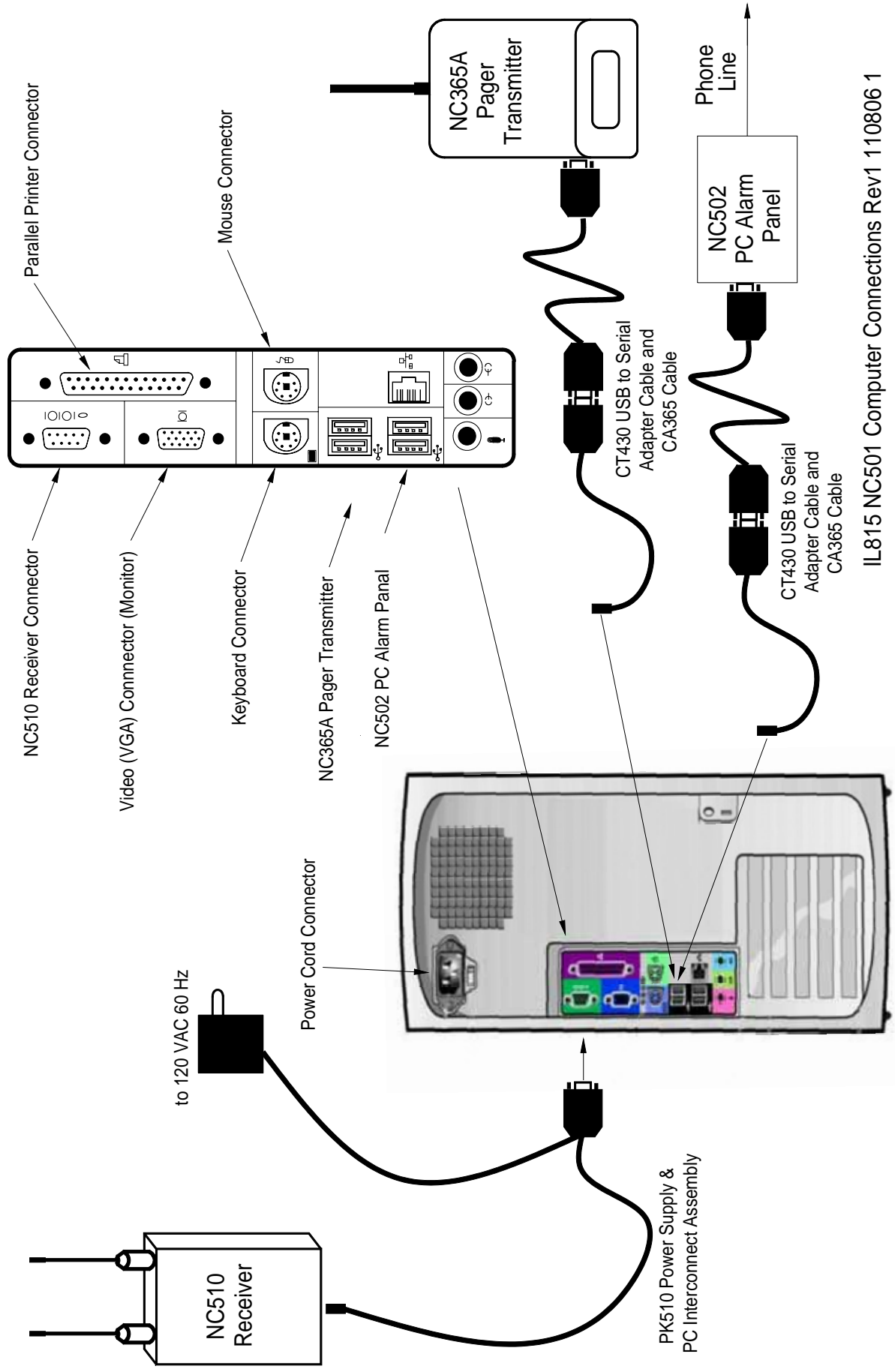

Figure 32—NC501 Master Station Computer Connections



IL815 NC501 Computer Connections Rev1 110806 1

NC365A Paging Transmitter/Control Unit—Connected directly to the NC501 Master Station Computer, the paging transmitter enables automatic and manual staff paging, when used with NC397 Pagers.

NC397 Alphanumeric Pocket Pager—Receives automatic and manual paging messages from the Tek-CARE®500 system, via the NC365A Paging Transmitter/Control Unit.

SF501 Water-Resistant Single Button Call Transmitter—A latching pendant transmitter with attachable necklace and belt clip, the SF501 places an alarm signal that can be reset only by pressing the reset button on its reverse.

SF502 Wall-Mounted Call Transmitter—The SF502 places an alarm signal that can be reset only at the Tek-CARE®500 NC501 Master Station Computer. Includes an attachable necklace for use as a portable transmitter.

SF505 Wireless Smoke Detector—Transmits an alarm signal when the smoke detector is activated. The signal will be reset automatically when the detector is clear of all smoke. **NOTE: The Tek-CARE®500 System is not tested as a fire alarm system and is not intended as a primary means of evacuation.**

SF515 Passive Infra-Red Detector—The SF515 is a motion detector that is sensitive to moving heat (infrared radiation). Can be used as a check-in device or a security device by monitoring activity.

SF520 Door/Window Egress Transmitter—Use to monitor door and window activity. May be used as either NO or NC to allow for a variety of applications. Alarms are automatically reset when returned to normal state.

SF525 Maintained NO Universal Contact Transmitter—Use with a maintained NO switch for a variety of applications. Alarms are automatically reset when returned to normal state.

SF526 Momentary NO Universal Contact Transmitter—Use with a momentary NO switch for a variety of applications. Alarms are automatically reset when returned to normal state.

SF527 Wireless Support Module with SF337C Waterproof Emergency Switch—Use in showers and bathrooms or anywhere a high priority call is desired. Alarms must be reset at point of origin.

SF528 Wireless Support Module with SF340B Emergency Switch (not waterproof)—Use where a high priority call is desired. Alarms must be reset at point of origin.

SF529/A Wireless Assistance Call & Resident Check-In Station—Use where a high priority call and resident check-in is desired. High priority calls must be reset at point of origin.

SF530 Single Patient Station—Use where call cord usage is desired. Alarms must be reset at point of origin.

SF531/A Wireless Emergency Call Station (not waterproof)—Use where a high priority call is desired. Alarms must be reset at point of origin.

CT430 USB to Serial Adaptor—Use to convert a USB port on the NC501 Master Station Computer to a serial COM port.

IH511 Weatherproof Housing—Provides indoor or outdoor mounting of an NC511 Repeater or an NC512 Locator, plus a BA510 Backup Battery.

IH527 Surface-Mount Single-Gang Plastic Back Box—for SF527/SF337C and SF528/SF340B Emergency Switch assemblies. To flush mount, use a plastic box that does not interfere with RF signals.

PK510 Power Supply and PC Interconnect Assembly—Convenient cable assembly supplies power to the NC510 Receiver and a serial connection from the NC510 Receiver to the NC501 Master Station Computer.

RP501 Replacement SF501 Accessory Kit—Replacement necklace and belt clip for the SF501 call transmitter.

SS014 AC Transformer—Replacement transformer and power supply for NC511 Repeaters and N512 Locators.

Battery Information

BA501—Replacement Battery for SF501

BA502—Replacement Battery for SF502

BA505—Replacement Battery for SF505, SF515, SF520, SF525, SF526, SF527, SF528, SF529/A, SF530, SF531/A

BA510—Backup Battery for NC511, NC512

Cross Reference Chart of Innovonics and TekTone® Part Numbers

Innovonics Part #	TekTone Part #	Description
ACC610	SS014	Replacement AC Transformer for NC511, NC512
ACC623A	RP501	Replacement necklace and belt clip for SF501
ACC640	IH511	Weatherproof Housing for NC511, NC512 with BA510
ACC643	PK510	Power Supply/PC Interconnect Assembly
BAT603	BA510	Backup Battery for NC511, NC512
BAT604	BA505	Replacement Battery for SF505, SF515, SF520, SF525, SF526, SF527, SF528, SF529/A, SF530, SF531/A
BAT608	BA502	Replacement Battery for SF502
BAT609	BA501	Replacement Battery for SF501
FA202	SF505	Wireless Smoke Detector
FA203S	SF502	Wall-Mounted Call Transmitter
FA206S	SF515	Passive Infra-Red Detector
FA210	SF525	Maintained NO Universal Contact Wireless Transmitter
FA210M	SF526	Momentary NO Universal Contact Wireless Transmitter
FA210W	SF520	Door/Window Egress Transmitter
FA223S-LTH	SF501	Water-Resistant Single Button Call Transmitter
FA403	NC510	Receiver
FA536	NC512	Locator
FA570	NC511	Repeater

Initial Programming

Paging Interface

If the system includes pagers, complete these steps first:

- Connect the NC365A Paging Transmitter to the NC501 Master Station Computer as shown in *Figure 32*.
- One paging transmitter has been pre-programmed in the Tek-CARE®500 master station computer (if ordered with the system). However, due to the dynamic method that MS Windows® uses to assign USB ports, the pager transmitter may be reassigned a different COM port (COM2, COM3, etc.) than was pre-programmed. Therefore, whenever the CT430 USB to Serial Adapter Cable is connected or reconnected to the PC, determine which COM port it has been assigned to—and then remove the existing paging interface settings and set up a new one (if the COM port has changed):

1. On the MS Windows® desktop, right-click on My Computer and then click on Properties.
 2. Click on the Hardware tab, click on the Device Manager button, and then click on the plus sign (+) next to “Ports.”
 3. In the list that appears, note which COM port the “USB to Serial Adapter” (or similar name) is assigned to.
 4. On the Tek-CARE®500 screen, click on Configure Menu and then click on Paging Interface Setup. If the Tek-CARE®500 COM Port number *is the same* as the MS Windows® Device Manager COM port number, skip step 5. If the two numbers are different, perform step 5. For more information, refer to *Figure 27* and *System Operating Instructions—Configure Menu—Paging Interface Setup*.
 5. If the COM port numbers are different, click on the Remove button on the Paging Interface Setup window. Next, click on the Add button to add a new Paging Transmitter using the MS Windows® Device Manager COM port number and then click on the Apply/Install button. Then exit the Tek-CARE®500 program and then restart it to complete the change.
- Create Paging Groups as described in *System Operating Instructions—Paging Menu—Paging Groups Register*.
 - Set the Default Paging Group (used in Night Mode) as described in *System Operating Instructions—Configure Menu—Paging Interface Setup*.
 - Add Pagers to the system and assign them to Paging Groups as described in *System Operating Instructions—Paging Menu—Pagers Register*.

Programming Transmitters, Locators and Repeaters

Next, program all transmitters, locators and repeaters and assign valid ID numbers to them, as follows:

- Valid ID numbers are hexadecimal numbers from 0001–FFFE (for a possible 65,534 addresses). **Note: The total number of transmitters must not exceed 1500.**
- For simplicity, assign each device type to a specific range of ID numbers. For example, assign 0001–0FFF to locators and repeaters, and assign 1000–1FFF to pendant transmitters.
- Open the Transmitters Register (F4) and then click the Add button to add the first device. (See *System Operating Instructions—Transmitters Menu—Transmitters Register (F4)* for more information.) When finished adding information for this device, click the Save button. Then click the Program Transmitter button and follow the on-screen instructions.
- Open both the receiver and the device being programmed so that their 3-pin programming header and reset buttons are accessible. (SF529/A and SF531/A stations have a connector on the programming header—note its orientation, and then remove it.) Connect the receiver’s programming cable from the 3-pin programming header of the device being programmed to the 3-pin programming header of the receiver. Either end of the cable may be connected to either device. Push the cable connector onto the 3-pin programming header in either direction. The connector must cover all three pins on the programming header. For SF529/A and SF531/A stations, push the programming cable’s connector onto the 3-pin programming header, orienting it so that the two conductors align with the pins previously connected to the pushbutton (SF529/A) or bridged by the jumper (SF531/A). For header locations, refer to the owner’s manual included with the receiver and the device being programmed.

Programming Error: Unable to write new settings into receiver memory. Operation terminated. If this error message is displayed, the receiver was busy handling supervision signals from the field. Click the Program Transmitter button to begin programming again. (This error becomes more common as the number of programmed devices increases. To avoid this error, remove the batteries and/or power from all transmitters, repeaters and locators, except the one being programmed—until all devices have been programmed.)

- Disconnect the programmed device from the receiver's programming cable. (For SF529/A and SF531/A stations, replace the connector on the programming header in its original orientation.) Repeat this procedure to program the next device.

Adding Residents

Add each resident to the Residents Register (F3), completing all relevant fields including assigned transmitters. (See *System Operating Instructions—Resident Menu—Residents Register (F3)* for more information.)

Set Up Database Maintenance Schedule

Create the database backup schedule and the purge schedule. TekTone® recommends backup to removable media (floppies or CD-Rs) on a regular schedule. See *System Operating Instructions—Configure Menu—Database Setup & Maintenance—Database Tab* for more information.

Customize the Software

Complete the following menu functions to customize the Tek-CARE®500 software for your facility:

- *System Menu—Night Mode (F8)*
- *System Menu—Zones Register*
- *System Menu—Edit Proximity Map*
- *Configure Menu—Tek-CARE®500 Options—Tek-CARE®500 Tab*
- *Configure Menu—Tek-CARE®500 Options—Passwords Tab*
- *Configure Menu—Customize Sounds*

If the system includes Central Monitoring, configure it as shown in the *Appendix: Central Monitoring* section.

System Troubleshooting Guide

An accurate site survey is critical to the installation of a trouble-free system. After installation, if transmissions are not reliably received, another site survey must be performed by a qualified TekTone® representative. Before beginning this site survey, disable all transmitters, including locators and repeaters, by removing batteries and other power sources. Perform the site survey as described in the NC500SK Survey Kit User Manual.

If isolated problems arise with individual transmitters, verify the correct programming instructions as outlined in *System Installation—Initial Setup and Programming—Programming Transmitters*. The following chart lists other possible equipment problems, their causes and recommended solutions.

Symptom	Possible Cause	Solution
Transmissions are not displayed on screen.	No power to the receiver.	Verify that receiver is plugged in. Verify that receiver is powered by removing its cover and checking that the three red LEDs are flashing.
	No connection or bad connection from the receiver to the PC.	Check the connections between the receiver and the PC. Verify that comm port setting in the configuration menu (signal interface setup) matches the actual connection.
	The receiver is damaged.	Contact TekTone® Technical Support.
Audio indications are not heard.	No power to the speakers and/or volume is turned down.	Verify that the speakers are connected to the PC and have power. Increase volume. Check MS Windows volume setting.
	No valid audio file has been selected.	Verify settings in configuration menu (customize sounds).
Can't print reports.	No power to the printer.	Verify that printer is connected and has power.
	Printer's settings are incorrect.	Check printer driver and configuration in MS Windows.
Messages are not sent to pagers.	No power to the pager transmitter.	Verify that pager transmitter is plugged in and red LED is lit.
	No connection or bad connection from the pager transmitter to the PC.	Check the connections between the pager transmitter and the PC. Verify that comm port setting in the configuration menu (paging interface setup) matches the actual connection.
	Paging groups are not defined and/or pagers are not assigned to groups.	Set up groups and assign pagers as described in manual.
	Pager transmitter has been damaged.	Contact TekTone® Technical Support.
System unexpectedly runs in demo mode.	Corrupt or altered program files.	Contact TekTone® Technical Support.

Appendix: Central Monitoring

Overview

Central Monitoring (CM) consists of two components: the *Central Monitoring Config Tool* and the *Central Monitoring Server*. The CM Server receives events (such as alarms, resets, and missing transmitters) from Tek-CARE®500 and then sends them via a USB/serial connection to the NC502 PC-Alarm Panel (see *Figure 32* for connections). The NC502 PC-Alarm panel dials the Central Monitoring facility's telephone number and transmits the events to the Central Monitoring facility. The CM Config Tool is used to configure the CM Server; double-click its desktop icon to run it. When the CM Server is running, it is shown as an icon in the system tray.

Central Monitoring (CM) Server

The CM Server runs as an icon in the system tray. Double-click this icon to show a log of server events (*Figure 33*). If the CM Server encounters an error, a pop-up notification window will appear. If the error is so severe that the CM Server stops functioning, its system-tray icon will display a red X.

After Central Monitoring has been enabled using the CM Config Tool, the CM Server starts automatically when Tek-CARE®500 starts and shuts down when Tek-CARE®500 shuts down.

Central Monitoring (CM) Config Tool

Double-click the CM Config Tool's desktop icon to run the program. The CM Config Tool includes three menus (File, Control and Tools) and three tabs (Event Details, Account Details and Configuration Details).

File Menu:

Commit Settings—Saves settings to the CM database. If the CM Server is running, it is shut down and restarted with the new settings.

Reload Settings from Database—Loads saved settings from the CM database, overwriting any changes just made.

Exit—Exits the program and prompts for changed settings to be saved to the CM database.

Control Menu:

Start/Reboot Server—Starts the CM Server. If the server is already running, it is shut down and restarted.

Shut down Server—Shuts down the CM Server.

Tools Menu:

List Devices—In the window that appears (*Figure 34*), select which information to display for each transmitter device: device number, type, associated resident and/or location. Click *OK* to create a list of all devices in the Tek-CARE®500 database, showing the selected properties for each device (*Figure 35*), plus each device's CM ID. The list opens in a text editor, and can be printed or saved as a text file. This list is used by the Central Monitoring facility to match the CM ID transmitted with an event to the more complete information found in the list.

Event Details Tab (Figure 36):

Enable Central Monitoring—When *Enable Central Monitoring* is checked, the CM Server starts when Tek-CARE®500 starts, and shuts down when Tek-CARE®500 shuts down.

Room Numbers—The CM Server responds only to events from the specified list of room numbers. Click the *Import Rooms* button to add all room numbers from the Tek-CARE®500 database.

Schedule—If *Unscheduled (always active)* is checked, the CM Server processes events whenever it is running. If *Unscheduled (always active)* is not checked, the CM Server processes events only during scheduled intervals, when the CM Server is running.

Account Details Tab (Figure 37):

Phone List—When sending an event, the CM Server tries each telephone number in order, and uses the first one that connects. If that telephone number stops working, the server continues through the list until it finds another working number. The CM Server retries once per minute until it connects.

Account Number—This 4-digit number is sent with every event to the Central Monitoring facility, and is used to identify the event's originating Tek-CARE®500 facility.

Dialing Options—Use this section to enter a prefix to disable call waiting, to enter a prefix to access an outside line, or to dial "1" before 10-digit telephone numbers.

Configuration Details Tab (Figure 38):

Alarm Panel COM Port—This is the port to which the NC502 PC-Alarm Panel is connected. If the wrong port is selected, the CM Server displays an error startup. To determine which port the NC502 PC-Alarm Panel is connected to:

Click on the *Start* menu and then click on *Control Panel*. Double-click on *System* and then click on the *Hardware* tab. Click on *Device Manager* and then double-click on *Ports (COM & LPT)*.

The list displayed should include *Communications Port (COM1)*, to which the NC510 Receiver is connected. The list should also include up to two *ATEN USB to Serial Bridge*—one connected to the NC365A Pager Transmitter, and the other connected to the NC502 PC-Alarm Panel.

Starting Central Monitoring

1. Verify that the Tek-CARE®500 system is running. Connect the NC502 PC-Alarm Panel to the NC501 Master Station Computer as shown in *Figure 32*.
2. From the desktop, double-click on the *Central Monitoring Config Tool*.
3. Under the Event Details tab, check *Enable Central Monitoring*.
4. Click *Import Rooms* to import rooms to be monitored from the Tek-CARE®500's database. Delete from the list those rooms you do not want to monitor.
5. Check *Unscheduled (always active)* to make Central Monitoring always active. Otherwise, set a monitoring schedule so that Central Monitoring will be active only during specified intervals. To add a schedule interval, click the *Add* button in the *Schedule* area, and then set a start day/time and a stop day/time. Each week, Central Monitoring will be active only between the start day/times and stop day/times of the intervals specified.
6. Select the *Account Details* tab. Enter the Central Monitoring facility's telephone number and click the *Add* button.
7. Enter the facility's 4-digit *Account Number*, as assigned by the Central Monitoring facility.
8. Configure *Dialing Options* as needed, to disable call waiting, to use a prefix to dial an outside line, or to dial "1" for 10-digit numbers.

Figure 33—CM Server

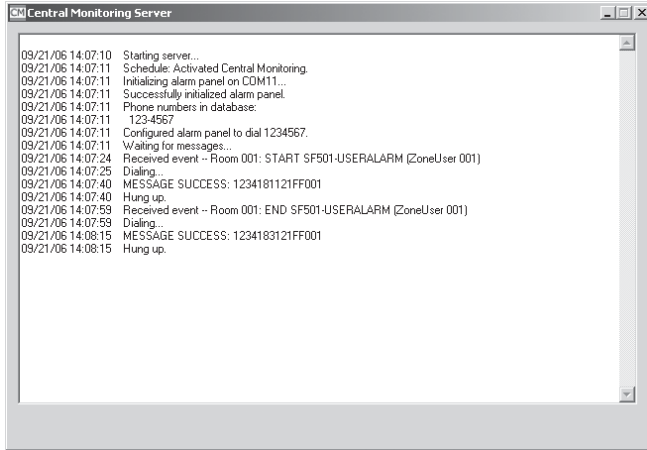

Figure 34—List Devices

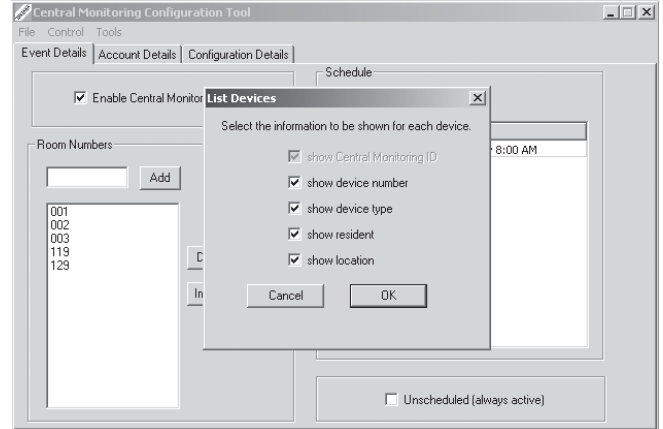

Figure 35—Device List

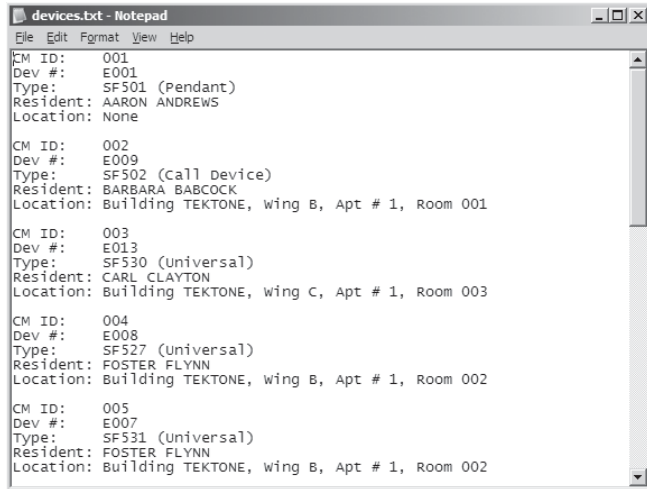

Figure 36—Event Details

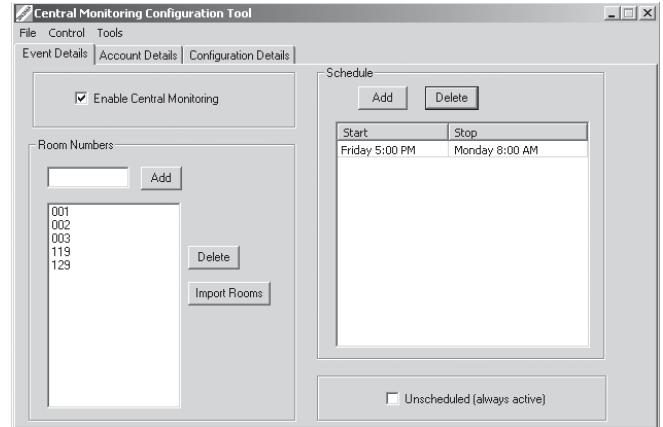

Figure 37—Account Details

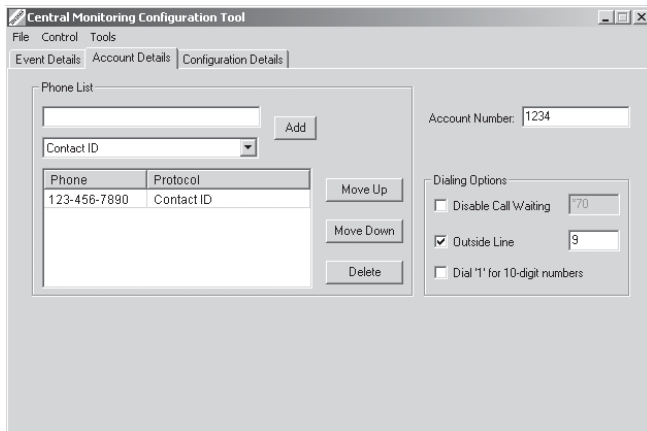
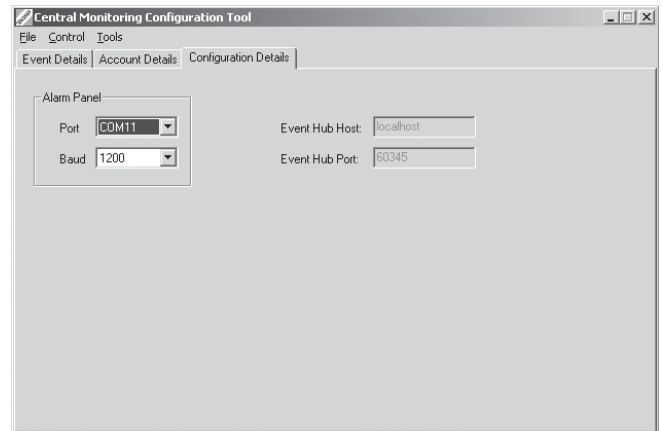

Figure 38—Configuration Details



9. Select the *Configuration Details* tab. Select the COM port to which the NC502 PC-Alarm Panel is attached:
 - On the MS Windows® desktop, right-click on *My Computer* and then click on *Properties*.
 - Click on the *Hardware* tab, click on the *Device Manager* button, and then click on the plus sign (+) next to “Ports.”
 - In the list that appears, note which COM port the “USB to Serial Adapter” (or similar name) is assigned to and select that COM port in the *Configuration Details* tab of the CM Config Tool. If the system also includes an NC365A Pager Transmitter, there will be two ports with names similar to “USB to Serial Adapter.” In that case, on the Tek-CARE®500 screen, click on *Configure Menu* and then click on *Paging Interface Setup* to determine which port the pager transmitter is using. Then assign the other COM port to the PC-alarm panel in the *Configuration Details* tab of the CM Config Tool.

Whenever the CT430 USB to Serial Adapter Cable is connected or reconnected to the PC, determine which COM port the PC-alarm panel has been assigned to—and modify this setting if the COM port has changed
10. From the *Control* menu, select *Start/Reboot Server*.
11. Click *Yes* to confirm that the CM Server is to be started and to save changes.
12. When the CM Server starts, its icon will appear in the system tray at the bottom-right of the screen.
13. The Central Monitoring (CM) Server is now running. It will start automatically whenever Tek-CARE®500 starts and will shut down whenever Tek-CARE®500 shuts down.

Stopping Central Monitoring

To shut down Central Monitoring manually, either select *Shut down server* from the *Control* menu of the CM Config Tool, or double-click the CM Server icon in the system tray and then close the window that appears.

To disable Central Monitoring and prevent it from starting with the Tek-CARE®500, uncheck *Enable Central Monitoring* in the *Event Details* tab of the CM Config Tool, select the *File* Menu, choose *Commit Settings*, and click *Yes* to save the settings.