

# Service Information User's Guide



## **CONTENTS**

---

**Introduction**  
**Starting & Using SI**  
**Finding Documents**  
**Navigating & Printing**  
**Viewing Documents**  
**Other Options**

©2004 GM Service and Parts Operations

---

# Service Information User's Guide

The Service Information (SI) User's Guide provides a comprehensive overview of SI software.

Everything contained in this manual is based on the latest product information available at the time of publication. The right is reserved to make changes at any time without notice.

No part of this publication may be reproduced, stored in any retrieval system, or transmitted in any form by any means, including but not limited to electronic, mechanical, photocopying, recording, or otherwise, without the prior written permission of GM Service and Parts Operations. This includes all text, tables, illustrations, and charts.

Requests for permission should be sent to:

General Motors Corporation  
Service and Parts Operations  
Product Engineering  
37350 Ecorse Road  
Romulus, MI 48174-1376  
U.S.A.

© 2003 GM Service and Parts Operations. Printed in the U.S.A. All rights reserved.

Microsoft Windows screen captures are used for instructional purposes.



---

# Customer Support Overview

To obtain assistance with a question or problem concerning the operation of your SI software, telephone the GM-Techline Customer Support Center.

---

## Before Calling

Before making a call to the Customer Support Center, be sure to have the following information ready:

- Dealership name, address and dealer code number
- Telephone number where the technician may be reached
- Tell when the problem occurred, and whether CD or Web usage
- List any error messages
- Give vehicle entry information

---

## Making the Call

The GM Service and Parts Operations **Techline Customer Support Center** telephone lines operate from 8:00 a.m. to 8:00 p.m. (Eastern Standard Time) Monday to Friday.

In the **United States** and **Canada** to contact Customer Support, dial:

- English: 1-800-828-6860 (option 1)
- French: 1-800-503-3222
- Customer Support fax line: 248-265-9327

For International Customer Support, fax all questions or comments to the customer support fax line.

A GM-Techline Customer Support representative will answer questions and make suggestions; and also will record each problem, question, or suggestion into a special problem tracking system. Any problems that cannot be resolved over the phone will be directed to the appropriate group for resolution.

---

# Software License Agreement

Please read this license agreement carefully before proceeding to operate the software. Rights to the software are offered only on the condition that the customer agrees to all terms and conditions of the license agreement. Proceeding to operate the equipment indicates your acceptance of these terms and conditions:

1. **USE:** Customer may use the software only on the computer system on which it was originally installed. Customer may not reverse assemble or decompile software unless authorized by law.
2. **OWNERSHIP:** Customer agrees that it does not have any title or ownership of the software, other than ownership of the physical media. Customer acknowledges and agrees that the software is copyrighted and protected under the copyright laws. Customer acknowledges and agrees that the software may have been developed by a third party software supplier named in the copyright notices included with the software, who shall be authorized to hold the Customer responsible for any copyright infringement or violation of this agreement.
3. **TERMINATION:** General Motors may terminate this software license for failure to comply with any of these terms provided GM has requested Customer to cure the failure and Customer has failed to do so within thirty (30) days of such notice.

---

# Using This Manual

To increase effectiveness with the Service Information (**SI**) software, users should familiarize themselves with the format and information contained in this guide.

## **IMPORTANT**

**SI** figures and illustrations are hyperlinked to the text of this manual. To view a figure, simply click on its description, which is shown in blue text. After viewing the figure, click on the rainbow-colored arrow at the lower left-hand corner of the screen to return to your place in the manual.

---

## SI Overview

**SI** is the software delivery tool for General Motors service information. **SI** contains General Motors service information including service manuals, owner's manuals, bulletins, and campaigns.

**SI** is available on the Internet and on CDs. **SI** is formatted in hypertext markup language (HTML), which can be viewed on any computer with an Internet browser, such as Microsoft® Internet Explorer.

---

## Finding Information on SI

Search for information in the following ways:

- Vehicle year, make, and model
- VIN number
- Keyword search
- Document number

You can find details about searching for service information beginning on page 5.

---

## Printing from SI

Connect to a printer. Print from the File menu, the Printer icon on the toolbar, or the Print button on the selected document.

---

# Apache Server Application

Apache is a powerful UNIX-based hypertext transfer protocol (http) server application that organizes the complex functions of **SI**. Apache must be running in order for **SI** to operate.

The Apache server application installs from the **SI** installation CD-ROM automatically. If you have Windows 2000 or XP, Apache runs transparently in the background.

After **SI** has been installed, Apache will start automatically every time the terminal is booted.

**Do not close Apache.**

**Note:** *If the Apache application is accidentally closed, the terminal must be rebooted in order to restart Apache and run **SI**.*

---

# Starting SI

You can access **SI** in three basic ways: on the Internet, by installing CDs, or by GM ACCESS (Canada).

---

## Web Access

- Open your Internet browser and enter **http://service.gm.com** in the address bar. At the GM Service and Parts Operations home page, click the **Service Information** tab (Figure 1).
  - Click the underlined text **Service Information** at the next screen (Figure 2).
  - Enter your user identification and password at the *Enter Network Password* screen (Figure 3) to open the Service Information home page (Figure 4).
- 

## Compact Disks

- Install the **SI** application and data on your computer using the **latest CDs** and **installation instructions**.
  - Double-click the “**eSI**” icon on the Desktop (Figure 5) to open the Service Information home page.
- 

## GM Access

- Double-click your **GM ACCESS** folder and select a **language** folder.
- Double-click the “**eSI**” **Service Information icon** to open the Service Information home page.



**Figure 1**  
*GM Service and Parts Operations home page*



**Figure 4**  
*Service Information system home page*



**Figure 2**  
*Service Information selected*



**Figure 5**  
*Service Information icon on Desktop screen*



**Figure 3**  
*Enter Network Password screen*



---

## SI's Home Page

The Service Information home page is shown in [Figure 4](#). Wherever your search leads you within the **SI** system, you can return to the home page by clicking the Home icon.



When you need information for a **specific vehicle**, use the **upper half** of the **SI home page** to initiate a search for GM service publications on the vehicle. A full description of this method begins on [page 6](#).

Use the **lower half** of the **SI home page** to select **other options**:



Unit repair manuals are published for specific engines, transmissions, and other components. Select the **Unit Repair Manual** icon to see a list of available manuals. See [page 11](#) for details.



If you have the ID number for a specific bulletin or campaign that you want to view, select the **Number Search** icon to enter the number and see the document. See [page 12](#) for details.



The **Latest News** icon allows you to review the latest released documents. Select the time period you wish to review, from two to eight weeks. See [page 12](#) for details.



Select the **YPK** icon and enter your desired **Year range + Platform + Keyword** to find bulletins, campaigns, and preliminary information. See [page 13](#) for details.



Operating instructions and other helpful hints are located under the **Question Mark** or **Help** icon. See [page 14](#) for details.

These links are also shown as bracketed text at the bottom of the screen, and are available for selection on most pages within the **SI** system. Clicking one of these icons or text links will open the start page for the particular function, no matter where you are within the system.

**Language Note:** **SI's** default language is English. You can select a different language from the drop-down menu at the **upper right** of the **SI home page** ([Figure 4](#)). If you are using CDs, you must first install the data CDs for the desired language before this option is available.

---

# Accessing GM Service Publications for Specific Vehicles

Follow the steps below and on the continuing pages to access service manuals, bulletins, and other publications available for a specific GM vehicle.

1. At the **SI** home page (Figure 4), you can initiate a vehicle specific search in two ways (Figure 6):
  - Select the vehicle year, make, and model from the respective drop-down menus and click **Next**, or
  - Click the line of bracketed text near the top of the screen to open the vehicle identification number (VIN) entry screen (Figure 7), enter the VIN, and then click **Submit**.
2. At the publication selection screen for the specified vehicle (Figure 8) you can select available options for the various types of publications, listed below.
  - **Service Manual/Bulletins**, which contain information on all optional and standard equipment for the specified vehicle (see Figure 9 and pages 7 to 10 for examples)
  - **Unit Repair** (see page 15)
  - **Owner's Manual** (see page 15)
  - **Owner's Manual Supplement** (see page 16)
  - **Owner's Warranty Books** (see page 16)

Subsequently in your search, you can return to the vehicle's publication selection screen (Figure 8) by clicking on the Publications icon, shown here.



3. After selecting a specific vehicle publication, a search screen similar to the one shown in Figure 9 gives you the option of **entering keywords** or **selecting a category** (see pages 7 and 8).



**Figure 6**  
*Enter VIN or "build" the vehicle*



**Figure 8**  
*Publication selection screen for specified vehicle*



**Figure 7**  
*VIN entry screen*



**Figure 9**  
*SI search screen*

---

## Searching for Service Information Using Keywords

1. At the search screen ([Figure 9](#)), **type a word or phrase** in the search field. Enter three words or fewer to optimize system performance.

**Note:** If you want to see a list of valid words and phrases, click on one of the lists named below the search field (e.g. Keyword, Symptom, or DTC), then click **Back** or **Previous Page** to return to the search screen.

2. Click **Search** (or press the Enter key), and every document with a title that contains the requested keyword(s) will appear. In the example shown in [Figure 10](#), the user typed “engine electrical” in the search field, and then clicked the search button. The program automatically adjusted the search term to “electrical engine” to facilitate the database search. [Figure 11](#) shows the resulting document list.
3. Click on the **title** of the document you wish to view.



**Figure 10**  
**Sample SI keyword search process**



**Figure 11**  
**Resulting list of available titles**

---

## Searching for Service Information by Category

Using this method, you make on-screen selections, “drilling down” from a general category to a more specific subcategory and eventually to the precise information for which you are searching. (As you click your way toward the final document, the path you chose is displayed near the top of the screen.)

1. At the search screen (Figure 9), select one of the categories listed at the left. In the Figure 12 example, the user selected “Steering” from the available categories.
2. At the next search screen(s), select from among the subcategories listed for your chosen category. In the example, the user selected “Steering Wheel and Column” (Figure 13) and subsequently “Diagnostic Information and Procedures” (Figure 14) from the available options.  
**Note:** After you select the primary category (e.g. Steering), the keyword search function offers you the option of searching the “Entire manual” or “This section only” (see Figure 13).
3. When you reach a document selection screen, click on the title of the document you wish to view. In the example shown in Figure 15, the user has selected the document “Lock System Does Not Lock,” which is a troubleshooting table (Figure 16).



**Figure 12**

*Steering selected from the category list on the first search screen (for service manual and bulletins)*



**Figure 13**

*Steering Wheel and Column selected from the category list on the next screen*



**Figure 14**

*Diagnostic Information and Procedures selected from the category list on the next screen*



**Figure 15**

*Lock System Does Not Lock selected from the document selection screen*



**Figure 16**

*Lock System Does Not Lock document displayed*

---

## Navigating and Printing Service Information Documents

The Document ID number appears at the top of your selected document. Use the Print button at the upper right to print the page, if desired. Use the Back and Forward buttons to return to the previous page or to advance to the next page (Figure 17).

Links are shown in blue text. The cursor changes to a hand when over a link. Click the link to open it. Links change color after they have been opened (Figure 16).

Scroll through the document using the scroll bar to the right of the document page. You can also use the Page Up and Page Down keys, or the arrow keys on your keyboard.



**Figure 17**  
**Document ID number, Back, Forward, and Print buttons indicated**

---

## Viewing Service Information Documents

Many documents contain images for which special viewing functions are available. For example, selecting **Repair Instructions** on the 2004 Cadillac SRX Steering Wheel and Column screen (Figure 18), and then selecting **Ignition Switch Replacement** on the resulting document selection screen (Figure 19) opens an illustrated repair instructions document (Figure 20).

Clicking the magnifying glass icon below each illustration opens an image viewing screen (Figure 21) with a special set of tools for viewing the image in more detail.



The image viewing toolbar icons are described in Figure 22.

**Note:** One of the tools, the mobile magnifier, is especially useful for viewing schematic drawings like the example shown in Figure 23.



**Figure 18**

*Repair Instructions selected from category list for the 2004 Cadillac SRX steering wheel and column*



**Figure 19**

*Ignition Switch Replacement document selected*



**Figure 20**

*Illustrated repair instructions*



**Figure 21**

*Image viewing screen showing toolbar*



**Figure 22**

*Description of SI image viewing toolbar icons*



**Figure 23**

*Sample schematic drawing showing the mobile magnifier tool function*

---

## Other Options

Other search options are available if you are not looking for service information for a specific vehicle. These options are described on page 5 as a group, and individually beginning below.

---

### Finding Information in Unit Repair Manuals

1. Click the Unit Repair icon, which occurs on the **SI** home page ([Figure 4](#)).
2. At the Unit Repair Manual selection screen ([Figure 24](#)), click the desired manual.
3. Click the desired category from those listed on the next screen ([Figure 25](#)), or search the whole unit repair manual by keyword (optional).
4. Click a subcategory from those listed on subsequent screens ([Figure 26](#)), narrowing your search to the final subcategory ([Figure 27](#)) to select and view the document you seek ([Figure 28](#), [Figure 29](#)).



**Figure 24**  
*Unit Repair Manual selection screen*



**Figure 25**  
*2004 Unit Repair category selection screen*



**Figure 26**  
*Unit repair subcategory selection screen*



**Figure 27**  
*Unit repair final category selection screen*



**Figure 28**  
*Unit repair document selection screen*



**Figure 29**  
*Unit repair document*

---

## Finding Information by a Number Search

1. Click the Number Search icon, which occurs on the **SI** home page and at the top of many other search screens throughout the system.
2. At the document number entry screen ([Figure 30](#)), enter the ID number of the document you seek.  
**Note:** You can omit dashes between numbers. You can also omit letters, or enter them in upper or lower case. For example, 980-08B can be written 98008b or 98008.
3. Click Search for Matching Document to open the corresponding document ([Figure 31](#)).



**Figure 30**  
*Document number entry screen*



**Figure 31**  
*Document with corresponding number displayed*

---

## Finding the Newest Publications

1. Click the Latest News icon, which occurs on the **SI** home page and at the top of many other search screens throughout the system.
2. Click to view the document of your choice.



**Note:** The screen shows bulletins, campaigns, and preliminary information released during the past four weeks. Narrow your search by selecting a two-week period from the drop-down menu, as shown in [Figure 32](#), or select a longer time period (six or eight weeks) to broaden your search. In the example, the user selected one of the bulletins ([Figure 33](#)), which subsequently appears on the screen ([Figure 34](#)).



**Figure 32**  
*Documents released during past four weeks*



**Figure 34**  
*Selected document displayed*



**Figure 33**  
*Search narrowed to most recent documents*



---

## Finding Information by a Year Range + Platform + Keyword Search

1. Click the Y+P+K icon, which occurs on the **SI** home page and at the top of many other search screens throughout the system.
2. At the Y+P+K entry screen (Figure 35):
  - Select a beginning model year
  - Select an ending model year
  - Select a vehicle platform
  - Enter a keyword or keywords\*
  - Click Submit
3. Select from among the resulting document list for your criteria (Figure 36) to view the document of your choice (Figure 37).



**Figure 35**  
*Y+P+K entry screen*



**Figure 37**  
*Selected document displayed*



**Figure 36**  
*Documents hit list resulting from Y+P+K search*

\*You may enter one, two, or three words in the Keyword field. If you enter the keywords “fuel” and “pump,” the search engine will look for “fuel pump.” Select a button to match **All** or **Any** of the entered words.

---

## Finding Assistance

1. Click the Help icon, which occurs on the **SI** home page and at the top of many other search screens throughout the system.
2. Select from the **SI** Help topics listed ([Figure 38](#)) to view your selection ([Figure 39](#)).



**Figure 38**  
*Service Information Help topics*



**Figure 39**  
*“Contacting Us for Assistance” displayed*

---

## Unit Repair Selection

This selection provides unit repair information. Complete specifications, component locator, repair instructions, and special tools and equipment for the specified vehicle are all covered under this selection.

1. Click the Unit Repair option, which appears on a vehicle's publication selection screen ([Figure 8](#)).
2. Click on the desired unit repair title from the resulting category list.
3. Repeat the previous step as your search narrows ([Figure 40](#)).
4. Select a document to view from the document list offered.



**Figure 40**  
*Example of a unit repair selection screen*

---

## Owner's Manual Selection

This selection provides specific owner's manual information for the vehicle requested. Complete owner's manual coverage is provided for seats and restraint systems, instrument panels, vehicle features and controls, service and care, maintenance schedules, and customer assistance information.

1. Click the Owner's Manual option, which appears on the publication selection screen if the owner's manual is available for the vehicle requested ([Figure 8](#)).
2. Click on the desired owner's manual title from the resulting category list.
3. Repeat the previous step as your search narrows.
4. Select a document to view from the document list offered.

---

## Owner's Manual Supplement Selection

This selection provides supplemental owner's manual information for the vehicle requested—for example, how to operate a vehicle's air conditioning, cellular phone, radio, navigation, voice recognition system, etc.

1. Click the Owner's Manual Supplement option, which appears on the publication selection screen if an owner's supplement is available for the vehicle requested ([Figure 8](#)).
2. Click on the desired owner's manual supplement title from the resulting category list.
3. Repeat the previous step as your search narrows.
4. Select a document to view from the document list offered.

---

## Owner's Warranty Book(s) Selection

This selection provides warranty and owner assistance information. Complete warranty coverage, new vehicle limited warranty, emission control systems warranties, and owner warranty assistance information are all covered under this selection for the vehicle requested.

1. Click the Owner's Warranty Books option, which appears on the publication selection screen if a warranty book is available for the vehicle requested ([Figure 8](#)).
2. Click on the desired warranty book title from the resulting category list ([Figure 41](#)).
3. Repeat the previous step as your search narrows.
4. Select a document to view from the document list offered.



**Figure 41**  
*Example of a warranty book selection screen*

# GM Service and Parts Operations

Home **Service Information** Forums Techline GM *Techlink* VCI Calibrations Related Sites

Service Information | Forums | Techline | GM *Techlink* On-line | Vehicle Calibration Information | Related Sites [Select Location](#)

## • **Service Information**

Service Manuals 1998 through present, Bulletins 1980 through present and PI's, Unit Repair Manuals, Document Number Search, Latest News and more.

## • **Service Information Forums (All US Dealer Regions)**

Communicate with other GM Dealership Professionals.

## • **Techline**

GM Techline Information, the latest TIS Updates and Techline.gm.com.

## • **GM *Techlink* On-line**

A Monthly Publication for GM Dealership Professionals.

## • **Vehicle Calibration Information**

Obtain the latest engine controller calibration information for a vehicle simply by entering the vehicle's 17 character Vehicle Identification Number (VIN).

## **Related Sites**

Web Sites for GM Dealership Professionals.

[gm.com/index\\_en-US/si.html](http://gm.com/index_en-US/si.html)

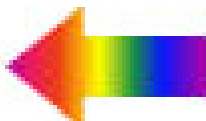

# GM Service and Parts Operations

- Home
- Service Information
- Forums
- Techline
- GM Techlink
- VCI Calibrations
- Related Sites

Service Information | Standalone Updates | Service Forms | Mode 6/OBD-II | RT/MR Install Guide [Select Location](#)

- [Service Information](#)

Service Manuals 1998 through present, Bulletins 1980 through present and PI's, Unit Repair Manuals, Document Number Search, Latest News and more.

- [Standalone Updates](#)

Latest updates for SI on a non-GM ACCESS server.

- [Service Forms](#)

The Service Forms site provides quick access to forms referenced by and included in bulletins. When additional bulletins or documents are referenced from the main bulletin, they are included below the main bulletin. Where available, printable versions of the forms are included.

- [Mode 6 On-Board Monitoring Test Results, and OBD-II Diagnostic Parameters](#)

Identification and scaling of J1979 mode 6 test values and limits data available on GM vehicles, for use with a generic scan tool. This area also includes detailed listings of GM OBD-II Diagnostic Parameters used by the On Board Diagnostic system, for each GM vehicle so equipped.

- [Radio Telephone/Mobile Radio Installation Guidelines](#)

General guidelines for installing a radio telephone or land mobile radio in General Motors vehicles.

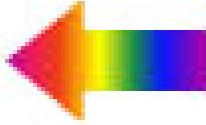

## Enter Network Password



Please type your user name and password.

Site: service.gm.com

Realm: SI2000 User Name

User Name

Password

Save this password in your password list

OK

Cancel

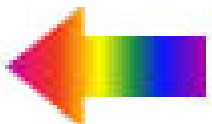

Service Information Home - Microsoft Internet Explorer

File Edit View Favorites Tools Help

 **Service and Parts Operations**

Select a language:  
English



**Service Information Home**  
To View a Service Publication,  
First Select the Year, Make and Model of the Vehicle and click on 'Next'  
[\[Or click here to enter a Vehicle Identification Number \(VIN\)\]](#)

Year:      Make:      Model:

Select Year   Select Make   Select Model   Next>>

Reset Vehicle Selection

---

**Select other options:**

-  Select and view a [Unit Repair](#)
-  Find a document by its ID, bulletin or campaign # in [Number Search](#)
-  See the newest bulletins, campaigns and preliminary information in [Latest News](#)
-  Find bulletins, campaigns and preliminary information by [Year Range + Platform + Keyword](#)
-  Confused? Get [Help](#) here

Send us your [feedback!](#)

---

[HOME] [UNIT REPAIR] [NUMBER SEARCH] [LATEST NEWS] [BULLETIN SEARCH] [HELP]

Local intranet

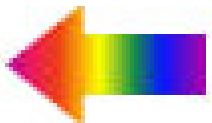

**Service Information home page**





**Service Information icon**

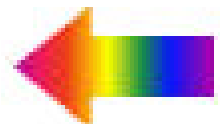

APACHE



3:10 PM



## Service Information Home

To View a Service Publication,  
First Select the Year, Make and Model of the Vehicle and click on 'Next'

[\[Or click here to enter a Vehicle Identification Number \(VIN\)\]](#)

Click  
this line  
to enter  
the VIN.



Year:	Make:	Model:	
Select Year ▼	Cadillac ▼	DeVille ▼	Next >>
Select Year ▲	Select Make	Select Model	
2004	Buick	CTS	
2003	Cadillac	DeVille	
2002	Chevrolet	Escalade	
2001	GMC Truck	Escalade ESV	
2000	Isuzu	Escalade EXT - 2WD	
1999	Oldsmobile	Escalade EXT - 4WD	
1998	Pontiac	SRX	
1997		Seville	
1996		XLR	
1995			

OR

Select the  
Year.

Select the  
Make.

Select the  
Model.

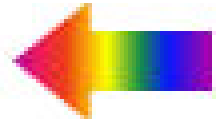







Service Information - Microsoft Internet Explorer

File Edit View Favorites Tools Help



Back Forward Stop Refresh Home Search Favorites History Print Print Preview Stop

Address <http://service.gm.com/servlets/VINSel> Go

 **Service and Parts Operations**

Enter the Vehicle Identification Number, then press 'Submit':

**Enter the VIN**     **and click Submit.**

Note: All VINs are 17 characters in length

---

[\[HOME\]](#) [\[NUMBER SEARCH\]](#) [\[LATEST NEWS\]](#) [\[BULLETIN SEARCH\]](#) [\[HELP\]](#)

Local intranet

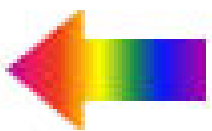

 **Service and Parts Operations**



You have selected the:

**2004 Cadillac SRX**

Select a vehicle publication to view:

**Service Manual/Bulletins**

[E SUV GMT265](#)

**Unit Repair**

[Unit Repair](#)

**Owner's Manual**

[Cadillac SRX Owner Manual](#)

**Owner's Manual Supplement**

[Cadillac SRX Entertainment and Navigation System](#)

**Owner's Warranty Books**

[Cadillac Warranty and Owner Assistance Information](#)

[Canadian Cadillac Warranty](#)

Optional Vehicle Information

# To find Service Information:

Select a category from the list...

OR

Select a category:

- [Bulletins By Category](#)
- [View All Bulletins](#)
- [Campaigns](#)
- [Preliminary Information](#)
- [Preface](#)
- [General Information](#)
- [HVAC](#)
- [Steering](#)
- [Suspension](#)
- [Driveline/Axle](#)
- [Brakes](#)
- [Engine](#)
- [Transmission/Transaxle](#)
- [Body](#)
- [Restraints](#)
- [Vehicle Control Systems](#)
- [Accessories](#)

 Service and Parts Operations



2004 Cadillac SRX

Match  All or  Any of these words:

[Keyword List](#) [Symptom List](#) [DTC List](#)

Enter a keyword...

(Type a word or phrase in the blank field or select from the Keyword, Symptom, or DTC list.)

and click Search.

**Note:** Bulletins, Campaigns and Preliminary Information may take longer to open.

[[HOME](#)] [[PUBLICATIONS](#)]  
[[NUMBER SEARCH](#)] [[LATEST NEWS](#)] [[BULLETIN SEARCH](#)] [[HELP](#)]

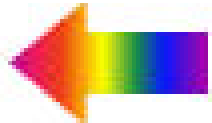



2004 Cadillac SRX

Match  All or  Any of these words:

[Keyword List](#) [Symptom List](#) [DTC List](#)

The program automatically adjusts the search term to "ELECTRICAL ENGINE."



Match  All or  Any of these words:

[Keyword List](#) [Symptom List](#) [DTC List](#)

Select a category:  
[Bulletins By Category](#)  
[View All Bulletins](#)  
[Campaigns](#)  
[Preliminary Information](#)  
[Preface](#)

The user types the term "engine electrical" in the search field and clicks the Search button.

Select a category:

- [Bulletins By Category](#)
- [View All Bulletins](#)
- [Campaigns](#)
- [Preliminary Information](#)
- [Preface](#)
- [General Information](#)
- [HVAC](#)
- [Steering](#)
- [Suspension](#)
- [Driveline/Axle](#)
- [Brakes](#)
- [Engine](#)
- [Transmission/Transaxle](#)
- [Body](#)
- [Restraints](#)
- [Vehicle Control Systems](#)
- [Accessories](#)

**Note:** Bulletins, Campaigns and Preliminary Information may take longer to open.

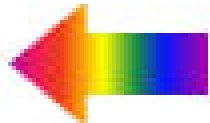

 **Service and Parts Operations**



**Search Results**

Searching for the following words: 'ELECTRICAL ENGINE'



**Engine Electrical**

- 1. [Engine Electrical Connector End Views](#)
- 2. [Engine Electrical Component Views](#)
- 3. [Diagnostic System Check - Engine Electrical](#)
- 4. [Symptoms - Engine Electrical](#)
- 5. [Diagnostic Starting Point - Engine Electrical](#)

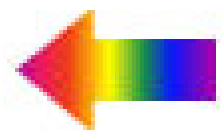



## 2004 Cadillac SRX

Match  All or  Any of these words:

[Keyword List](#) [Symptom List](#) [DTC List](#)

### Select a category:

- [Bulletins By Category](#)
- [View All Bulletins](#)
- [Campaigns](#)
- [Preliminary Information](#)
- [Preface](#)
- [General Information](#)
- [HVAC](#)
- [Steering](#)
- [Suspension](#)
- [Driveline/Axle](#)
- [Brakes](#)
- [Engine](#)
- [Transmission/Transaxle](#)

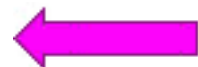

Steering category selected

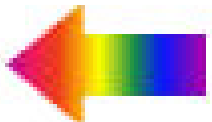





2004 Cadillac SRX - Steering

Match  All or  Any of these words:  
   
 Entire Manual  This section only

Keyword search options:  
"Entire manual" or  
"This section only"

Select a category:

- > [Bulletins By Category](#)
- > [View All Bulletins](#)
- > [Campaigns](#)
- > [Preliminary Information](#)
- > [Power Steering System](#)
- > [Steering Wheel and Column](#)
- > [Variable Effort Steering](#)

Steering Wheel and Column category selected

**Note:** Bulletins, Campaigns and Preliminary Information may take longer to open.

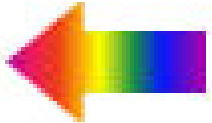



2004 Cadillac SRX - Steering - Steering Wheel and Column

Match  All or  Any of these words:  
 Search

Entire Manual  This section only

[Keyword List](#) [Symptom List](#) [DTC List](#)

Select a category:

- [Specifications](#)
- [Schematic and Routing Diagrams](#)
- [Component Locator](#)
- [Diagnostic Information and Procedures](#)
- [Repair Instructions](#)
- [Description and Operation](#)
- [Special Tools and Equipment](#)



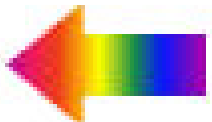







 **Diagnostic Information and Procedures category selected**





2004 Cadillac SRX - Steering - Steering Wheel and Column - Diagnostic Information and Procedures

Select a document to view:

-  [Symptoms - Steering Wheel and Column](#)
-  [Steering Column Tilt Function Inoperative](#)
-  [Ignition Can/Cannot Be Turned Off with Transmission in Any Gear](#)
-  [Lock System Does Not Unlock](#)
-  [Lock System Does Not Lock](#)
-  [Lock System Sticks in Start](#)
-  [Key Cannot Be Removed in the Off Lock Position](#)
-  [High Lock Effort](#)
-  [Noise in Steering Column](#)
-  [Looseness in Steering Column](#)



The user has selected the document **Lock System Does Not Lock.**

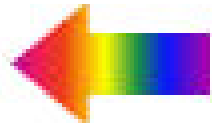

# Lock System Does Not Lock

Step	Action	Yes	No
DEFINITION: The lock system will not allow the key to be turned to the OFF lock position.			
1	Did you review the Steering Wheel and Column Description and Operation?	Go to <a href="#">Step 2</a>	Go to <a href="#">Steering Wheel and Column Description and Operation</a>
2	Verify that the lock system does not lock. Does the lock system operate normally?	System OK	Go to <a href="#">Step 3</a>
3	Inspect for a faulty lock cylinder or release button. Is the lock cylinder or release button damaged?	Go to <a href="#">Step 7</a>	Go to <a href="#">Step 4</a>
4	Inspect the shift linkage adjustment. Is the shift linkage adjusted incorrectly?	Go to <a href="#">Step 8</a>	Go to <a href="#">Step 5</a>

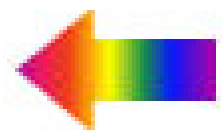

Service Information - Microsoft Internet Explorer

File Edit View Favorites Tools Help

Back Forward Stop Refresh Home Search Favorites History Mail Print

Address <http://127.0.0.1:9001/servlets/BlobServlet?ServletFile=797914&evc=sm&pubid=480&cellid=58841&msspsdsubkey=2695> Go

<- Back Forward ->

Document ID# 797914  
2004 Cadillac SRX

Print

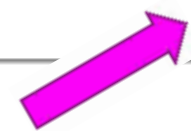
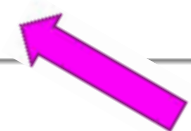
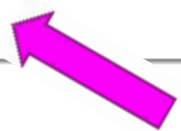

# Lock System Does Not Lock

Step	Action	Yes	No
DEFINITION: The lock system will not allow the key to be turned to the OFF lock position.			
1	Did you review the Steering Wheel and Column Description and Operation?	Go to <a href="#">Step 2</a>	Go to <a href="#">Steering Wheel and Column Description and Operation</a>
2	Verify that the lock system does not lock. Does the lock system operate normally?	System OK	Go to <a href="#">Step 3</a>
3	Inspect for a faulty lock cylinder or release button. Is the lock cylinder or release button damaged?	Go to <a href="#">Step 7</a>	Go to <a href="#">Step 4</a>
4	Inspect the shift linkage adjustment. Is the shift linkage adjusted incorrectly?	Go to <a href="#">Step 8</a>	Go to <a href="#">Step 5</a>

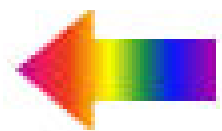

 **Service and Parts Operations**



[2004 Cadillac SRX](#) - [Steering](#) - Steering Wheel and Column

Match  All or  Any of these words:  
 Search  
 Entire Manual  This section only

[Keyword List](#) [Symptom List](#) [DTC List](#)

Select a category:

- [Specifications](#)
- [Schematic and Routing Diagrams](#)
- [Component Locator](#)
- [Diagnostic Information and Procedures](#)
- [Repair Instructions](#)
- [Description and Operation](#)
- [Special Tools and Equipment](#)

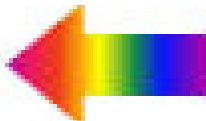

**GM Service and Parts Operations**



**2004 Cadillac SRX - Steering - Steering Wheel and Column - Repair Instructions**

Select a document to view:

- [Seal Replacement - Intermediate Steering Shaft](#)
- [Intermediate Steering Shaft Replacement - Upper](#)
- [Intermediate Steering Shaft Replacement - Center](#)
- [Intermediate Steering Shaft Replacement - Lower](#)
- [Steering Column Accident Damage Inspection](#)
- [Steering Column Trim Covers Replacement](#)
- [Ignition Switch Replacement](#)
- [Ignition Lock Cylinder Replacement](#)
- [Ignition Lock Cylinder Case Replacement](#)
- [Multifunction, Turn Signal Switch Replacement](#)

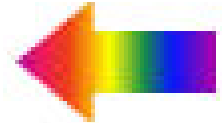

[ver Replacement](#)

# Ignition Switch Replacement

## Tools Required

[J 42759](#) Ignition Switch Connector Release Tool

## Removal Procedure

### Caution

Refer to [SIR Caution](#) in Cautions and Notices.

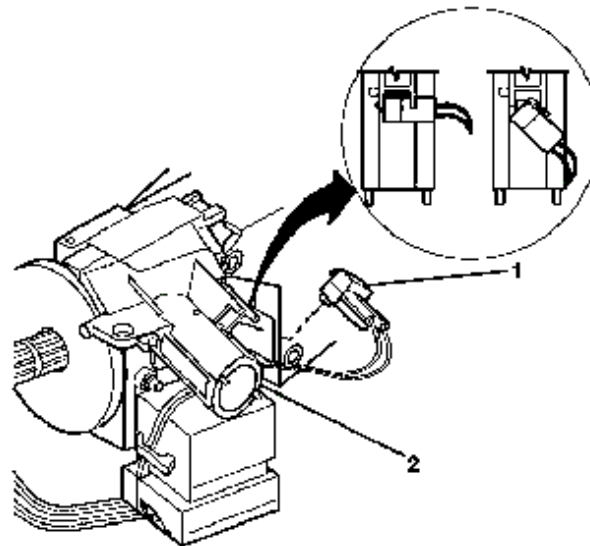

1. Disable the SIR system.
2. Remove the theft deterrent control module. Refer to [Theft Deterrent Control Module Replacement](#) in Theft Deterrent.
3. Rotate the key alarm connector (1) 90 degrees.
4. Gently pull the key alarm connector (1) out of the ignition lock cylinder case assembly (2).

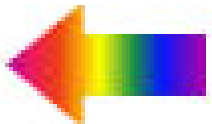



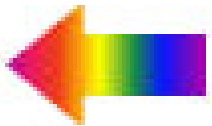
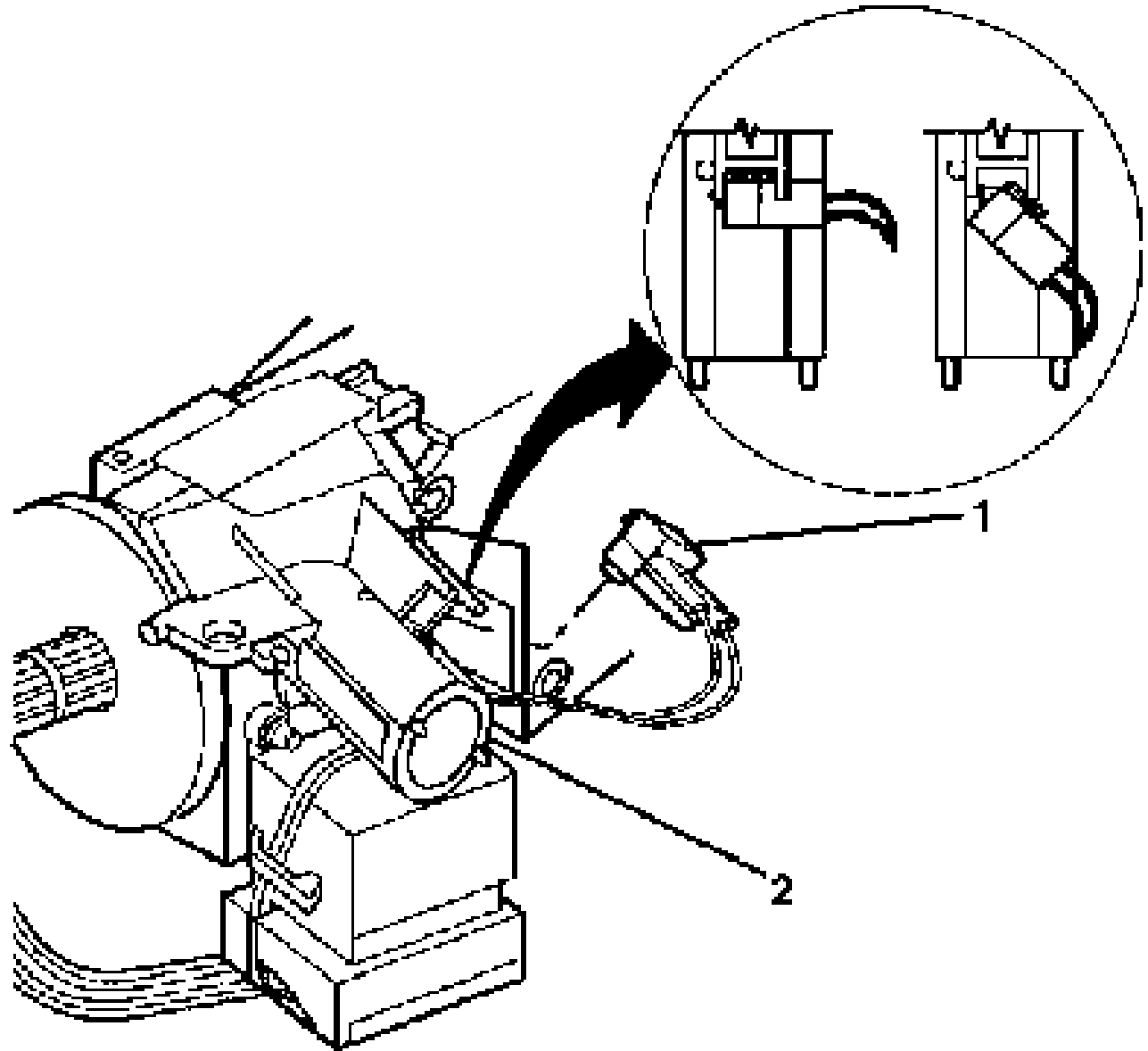
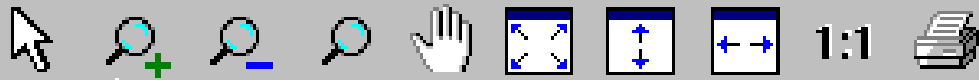

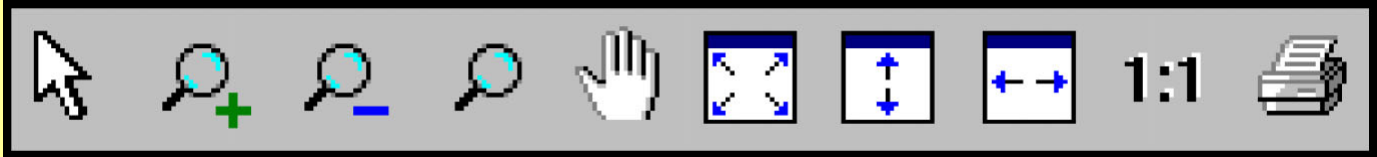

### Return to Arrow Cursor

Returns to an arrow cursor from a previously selected magnifying glass or image mover.



### Magnifying Glass Plus (+)

Enlarges image size.



### Magnifying Glass Minus (-)

Decreases image size.



### Mobile Magnifier

Allows the user to scan a magnified image. Press and hold the left mouse button.



### Image Mover

Allows the user to move the image while in an enhanced mode.



### Fit to Screen

Resizes the image to fit your screen.

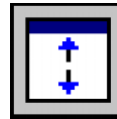

### Fit to Height

Resizes the image to fit the height of your screen, regardless of width.

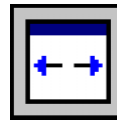

### Fit to Width

Resizes the image to fit the width of your screen, regardless of height.



### Original Image

Restores the original image.



### Print

Prints the page.

**Service Information image viewing icons**



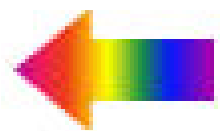
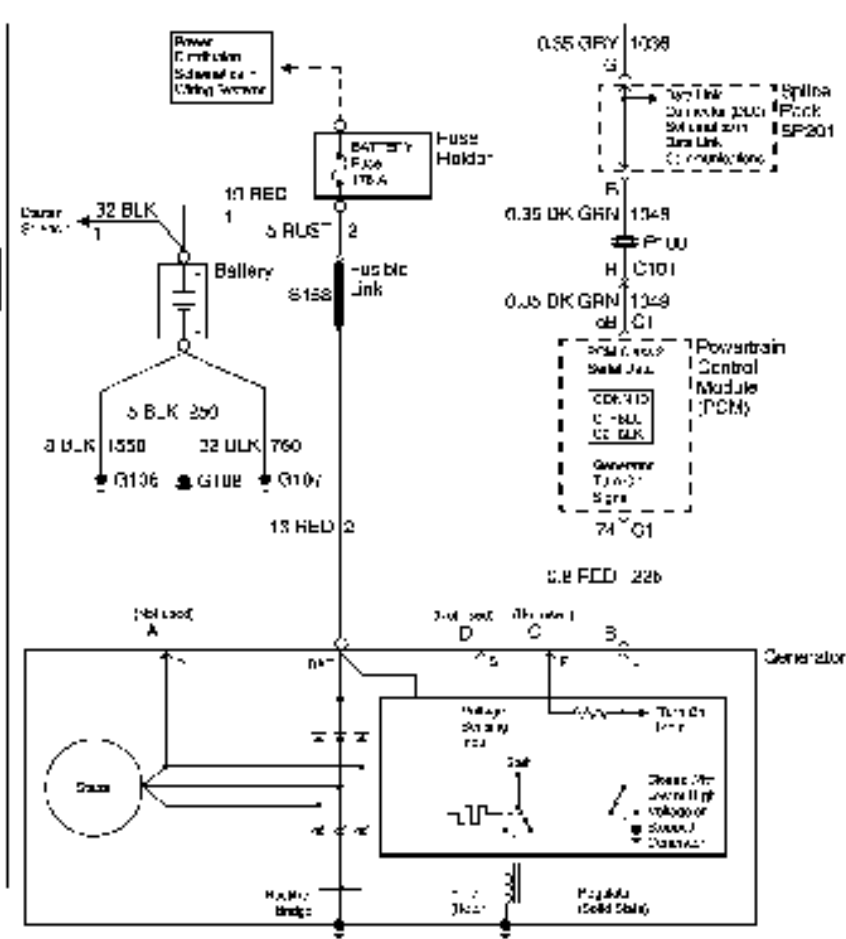
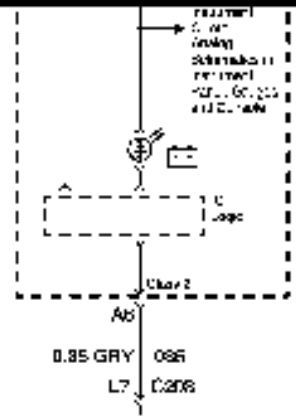
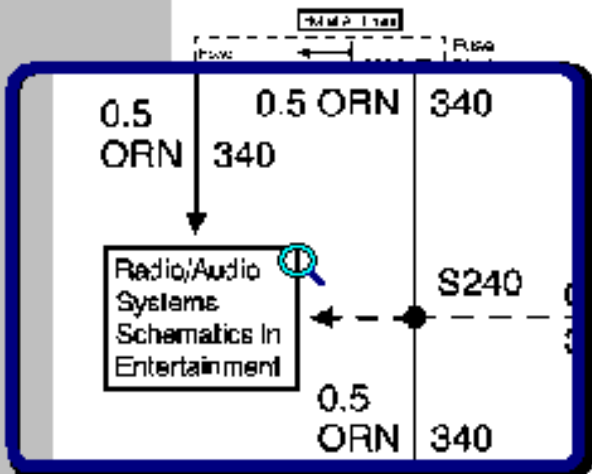







Service Information - Microsoft Internet Explorer

File Edit View Favorites Tools Help

Back Forward Stop Refresh Home Search Favorites History Mail Print

Address <http://127.0.0.1:9001/servlets/URList> Go

 **Service and Parts Operations**

    

To view a Unit Repair Manual, click on the desired manual from the list below:

- [1997 Transmissions](#)
- [1998 Transmissions](#)
- [1999 Transmissions](#)
- [2000 Transmissions](#)
- [2001 Unit Repair](#)
- [2002 Unit Repair](#)
- [2003 Unit Repair](#)
- [2004 Unit Repair](#)

[HOME] [NUMBER SEARCH] [LATEST NEWS] [BULLETIN SEARCH] [HELP]

1:9001/servlets/UR SCT?booktypeid=2&bookid=31&pubpsdid=433&title=2004+Unit+Repair Local intranet

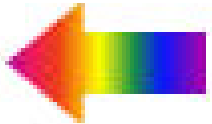

 **Service and Parts Operations**



## 2004 Unit Repair

Match  All or  Any of these words:

[Keyword List](#)

**Select a category:**

- [Preface](#)
- [General Information](#)
- [Driveline/Axle](#)
- [Transmission/Transaxle](#)

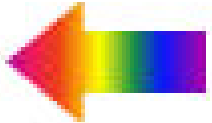

 **Service and Parts Operations**



## 2004 Unit Repair - Transmission/Transaxle

Match  All or  Any of these words:  
   
 Entire Manual  This section only

[Keyword List](#)

### Select a category:

- [Automatic Transmission - 4L60-E/4L65-E](#)
- [Automatic Transmission - 4L80-E/4L85-E](#)
- [Automatic Transmission - 5L40-E/5L50-E](#)
- [Automatic Transaxle - 4T40-E/4T45-E](#)
- [Automatic Transaxle - 4T65-E](#)
- [Automatic Transaxle - 4T80-E](#)

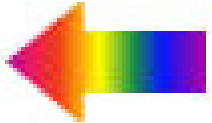

 **Service and Parts Operations**



2004 Unit Repair - Transmission/Transaxle - Automatic Transmission - 4L60-E/4L65-E

Match  All or  Any of these words:  
   
 Entire Manual  This section only

[Keyword List](#)

Select a category:

- [Specifications](#)
- [Component Locator](#)
- [Repair Instructions](#)
- [Description and Operation](#)
- [Special Tools and Equipment](#)

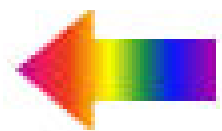

 **Service and Parts Operations**



[2004 Unit Repair - Transmission/Transaxle - Automatic Transmission - 4L60-E/4L65-E - Repair Instructions](#)

Select a document to view:

-  [Do Not Use Air Tools](#)
-  [Holding Fixture Installation](#)
-  [Torque Converter Assembly Removal](#)
-  [Drain Oil](#)
-  [Converter Housing Removal](#)
-  [2-4 Servo Cover and Assembly Removal](#)
-  [2-4 Servo Pin Length Check](#)
-  [Speed Sensor and Case Extension Removal 2WD Applications Only](#)
-  [Pan and Filter Assembly Removal](#)
-  [Auxiliary Pump Removal PHT Models](#)
-  [Body and Wiring Harness Removal](#)
-  [e Shaft O-Ring Removal](#)

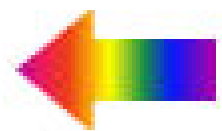



< Back Forward >

Document ID # 191291

Print

# Drain Oil

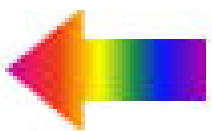
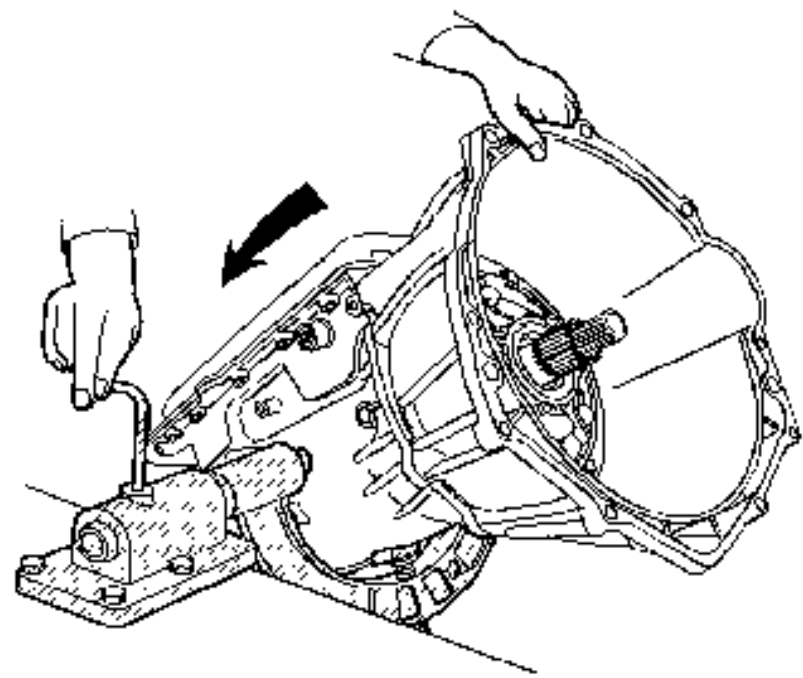





Service Information - Microsoft Internet Explorer

File Edit View Favorites Tools Help

Back Forward Stop Home Search Favorites History Print Copy Paste

Address <http://service.gm.com/servlets/NumSearchSel> Go

## GM Service and Parts Operations

Enter a Bulletin/Campaign #:

Search for Matching Document

---

Enter a Document ID:

Search for Matching Document

[\[HOME\]](#) [\[NUMBER SEARCH\]](#) [\[LATEST NEWS\]](#) [\[BULLETIN SEARCH\]](#) [\[HELP\]](#)

Done Local intranet

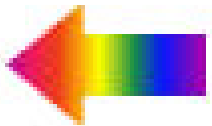

Service Information - Microsoft Internet Explorer

File Edit View Favorites Tools Help

Back Forward Stop Home Search Favorites History

Address <http://service.gm.com/servlets/BlobShtml?ShtmlFile=303649&evc=numSrch&version=html&Language=en-US> Go Links

<- Back Forward -> Document ID # 303649 Print

## Splicing Twisted or Shielded Cable

Twisted/shielded cable is used in order to protect wiring from electrical noise. Two-conductor cable of this construction is used between the radio and the Delco-Bose® speaker/amplifier units and other applications where low level, sensitive signals must be carried. Follow the instructions below in order to repair the twisted/shielded cable.



The diagram shows a cross-section of a twisted pair cable. It consists of two insulated conductors twisted together, surrounded by a braided shield. A hand is shown peeling back the outer jacket of the cable. A dashed line with the number '1' points to the twisted pair conductors.

Local intranet

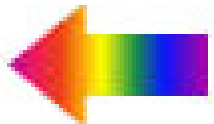



Documents which have arrived in the last 4 weeks

## Bulletins

### Body and Accessories

1. [#03-08-49-014A Fuel Gauge Fluctuates Between E and 1/4 Tank, Goes from 1/4 to Empty Too Quickly, Excessive Empty Fuel Reserve \(Reprogram PCM\) - \(Oct 2, 2003\)](#)
2. [#03-07-30-047 Diagnostic Information for Various Shift Conditions - Inadvertent IP Switch Activation - \(Oct 2, 2003\)](#)
3. [#03-08-58-005 Wind Noise at Highway Speeds from Base of Driver Side \(Left\) A-Pillar Near VIN Plate Area \(Seal Area with Seam Sealer\) - \(Oct 2, 2003\)](#)
4. [#03-08-66-011 SMA Spare Tire Carrier May Rattle Over Rough Surfaces, T-Pin Lock Difficult to Remove \(Install Revised Latch Isolator and Verify Installation fo Anti-Rotation Bolts in Hinge Bracket\) - \(Oct 2, 2003\)](#)
5. [#03-08-51-002 Warranty Admin. - Changes to Paint Claim Submission Process - Paint Mix Time Must Be Entered on Each Line - \(Oct 2, 2003\)](#)

### Transmission/Transaxle

1. [#PI01395A Shifter Adjustment for Manual Driver Shift Control - 5L40E 5L50E adjust indicator inoperative manual transmission - \(Oct 1, 2003\)](#)
2. [#PI01129A Allison LCT1000 Serviceability - delay default drive DTC engage forward gear inoperative intermittent LCT 1000 loss MIL operation part repair reverse shift TCM transmission slip - \(Sep 25, 2003\)](#)
3. [#PI01385 4T40E Surge , Slip Condition Under Load in 2nd , 3rd and/or 4th - body chuggle fourth hesitation hot LG8 miss second shift third valve - \(Sep 25, 2003\)](#)
4. [#PI01373 Service VME - High Effort to Move Shift Lever - 4T40E 4T45E hard - \(Sep 18, 2003\)](#)

To see the documents which have arrived during a different time interval, please select the time from the list below, and press **Submit**:



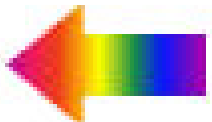

2 Weeks   
2 Weeks  
4 Weeks  
6 Weeks  
8 Weeks



Service Information - Microsoft Internet Explorer

File Edit View Favorites Tools Help

 **Service and Parts Operations**

Documents which have arrived in the last 2 weeks

## Bulletins

### Body and Accessories

1. [#03-08-49-014A Fuel Gauge Fluctuates Between E and 1/4 Tank, Goes from 1/4 to Empty Too Quickly, Excessive Empty Fuel Reserve \(Reprogram PCM\) - \(Oct 2, 2003\)](#)
2. [#03-07-30-047 Diagnostic Information for Various Shift Conditions - Inadvertent IP Switch Activation - \(Oct 2, 2003\)](#)
3. [#03-08-58-005 Wind Noise at Highway Speeds from Base of Driver Side \(Left\) A-Pillar Near VIN Plate Area \(Seal Area with Seam Sealer\) - \(Oct 2, 2003\)](#)
4. [#03-08-66-011 SMA Spare Tire Carrier May Rattle Over Rough Surfaces, T-Pin Lock Difficult to Remove \(Install Revised Latch Isolator and Verify Installation fo Anti-Rotation Bolts in Hinge Bracket\) - \(Oct 2, 2003\)](#)
5. [#03-08-51-002 Warranty Admin. - Changes to Paint Claim Submission Process - Paint Mix Time Must Be Entered on Each Line - \(Oct 2, 2003\)](#)
6. [#03-08-42-006A Info - Tail Lamp Circuit Board Now Available for Service Use - \(Oct 1, 2003\)](#)
7. [#03-08-67-007 Creak in Roof \(Install Insulator\) - \(Oct 1, 2003\)](#)
8. [#03-08-57-004 Wet Front Floor Carpet \(Install Plastic Nuts in A-Pillar or Apply Weatherstrip Adhesive\) - \(Oct 1, 2003\)](#)
9. [#02-T-20 SMU for 2002 VUE Body Electrical Diagnostics Service Manuals Regarding AM/FM Stereo with Cassette and 6-Disc CD Player Check Charts - \(Sep 30, 2003\)](#)
10. [#00-T-17C Headliner Sags or Hangs Too Low at Rear of Sunroof Opening - \(Sep 30, 2003\)](#)
11. [#02-T-05 SMU for 2000-2001 L-Series Body/Electrical Volume II Service Manuals Regarding Front Seat Cushion Cover/Pad Removal and Installation - \(Sep 30, 2003\)](#)
12. [#03-08-48-006 Repair Information for Reconnection of Rear Window Defroster Contact or Tab - \(Sep 29, 2003\)](#)

### Brakes

1. [#03-05-25-008 Intermittent/Constant ABS MIL Illuminated \(Replace Both Frotn Wheel Speed Harnesses\) - \(Oct 1, 2003\)](#)

http://service.gm.com/servlets/BlobShtml?ShtmlFile=1389176 Local intranet

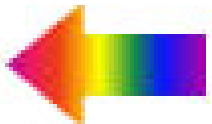

Service Information - Microsoft Internet Explorer

File Edit View Favorites Tools Help

<- Back Forward -> Document ID# 1389176 Print

## Fuel Gauge Fluctuates Between E and 1/4 Tank, Goes from 1/4 to Empty Too Quickly, Excessive Empty Fuel Reserve (Reprogram PCM) #03-08-49-014A - (10/02/2003)

Fuel Gauge Fluctuates Between E and 1/4 Tank, Goes From 1/4 to Empty Too Quickly, Excessive Empty Fuel Reserve (Reprogram PCM)

2001-2003 Chevrolet Blazer

2001 GMC Envoy

2001-2003 GMC Jimmy

This bulletin is being revised to add condition information. Please discard Corporate Bulletin Number 03-08-49-014 (Section 08 -- Body and Accessories).

This bulletin contains three different conditions depending on the model year of the vehicle involved.

**Condition #1 (2001 4-Door Only)**

Some customers may comment that the fuel gauge goes from 1/4 to empty too quickly.

**Condition #2 (2002 4-Door Only)**

Some customers may comment about excessive empty fuel reserve.

**Condition #3 (2003 2-Door and 4-Door)**

Some customers may comment that the fuel gauge fluctuates between E and 1/4 tank.

Done Local intranet

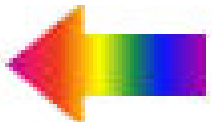





Service Information - Microsoft Internet Explorer

File Edit View Favorites Tools Help

Back Forward Stop Home Search Favorites History Print Copy Paste

## GM Service and Parts Operations

To Search for Bulletins, Campaigns or Preliminary Information, Select the Starting model year, Ending model year, Vehicle, Type a keyword and click on 'Submit'

Start: 2003 End: 2004 Platform: Y Car Keyword: ABS Submit

Match  All or  Any of these words: Reset

[\[HOME\]](#) [\[NUMBER SEARCH\]](#) [\[LATEST NEWS\]](#) [\[BULLETIN SEARCH\]](#) [\[HELP\]](#)

Local intranet

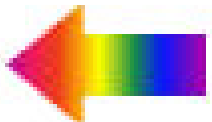





Service Information - Microsoft Internet Explorer

File Edit View Favorites Tools Help

Back Forward Stop Home Search Favorites History Print

 **Service and Parts Operations**

### Search Results

Searching for the following word: 'ABS'

1. [#PI01398 Rattle Resonance Rear of Vehicle During Acceleration - absorber accelerate axle bracket damper differential exhaust insulator launch moan mount noise torque transmission turn vibration weight - \(Oct 1, 2003\)](#)
2. [#PI01320 Service VME - Brake Squeal and Brake Dust Accumulation - ABS TCS wheel - \(Aug 18, 2003\)](#)
3. [#02-06-03-006A No Start, No Crank, Battery, Batteries, Generator, Gages, SES, SIR, Brake Security, Theft, ABS, Hot, DIC Messages, Lamp, Light, Battery and Generator Diagnostic Testing, and Cadillac Roadside Service - \(Nov 26, 2002\)](#)
4. [#02-06-03-011 Electrical System Diagnostic Work Sheet, No Start, No Crank, Battery, Batteries, Generator, Gages, SES, SIR, Brake, Security, Theft, ABS, Hot DIC Messages, Lamp, Light, Battery/Generator Diag. Testing - \(Oct 30, 2002\)](#)
5. [#02-06-03-012 Proper Diagnostic Procedures for No Start, No Crank, Battery, Batteries, Generator, Gauges, SES, SIR, Brake, Security, Theft, ABS, Hot, DIC Messages, Lamp, Light, Battery and Generator Diag. Testing - \(Oct 25, 2002\)](#)

[HOME] [NUMBER SEARCH] [LATEST NEWS] [BULLETIN SEARCH] [HELP]

http://service.gm.com/servlets/BlobShtml?ShtmlFile=1205192&psdid=0 Local intranet

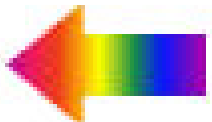



# **No Start, No Crank, Battery, Batteries, Generator, Gages, SES, SIR, Brake, Security, Theft, ABS, Hot, DIC Messages, Lamp, Light, Battery and Generator Diagnostic Testing, and Cadillac Roadside Service #02-06-03-006A - (11/26/2002)**

No Start, No Crank, Battery, Batteries, Generator, Gages, SES, SIR, Brake, Security, Theft, ABS, Hot, DIC Messages, Lamp, Light, Battery and Generator Diagnostic Testing, and Cadillac Roadside Service, Warranty Claims Procedure (Proper Diagnostic Procedures)

1997-2003 Passenger Cars and Trucks (Except Electric Vehicles)

2003 HUMMER H2

This bulletin is being revised to clarify the Service Procedures and update the Warranty Section. Please discard Corporate Bulletin Number 02-06-03-006 (Section 06 -- Engine).

IF YOU WISH TO PRINT THE ELECTRICAL SYSTEM DIAGNOSTIC WORK SHEET ONLY, YOU MAY REFER TO CORPORATE BULLETIN NUMBER 02-06-03-011.

## **Condition**

Some customers may have comments regarding any one or more of the following conditions:

1. Intermittent illumination of one or more of the following instrument panel warning lamps:
  - o SES light
  - o Generator light
  - o SIR light
  - o Brake light
  - o Security, theft light
  - o ABS light
  - o Hot light
2. Gage readings which seem to be incorrect.
3. Erratic RPM display on the Tachometer.
4. Engine is difficult /hard to start.
5. Engine will not crank.
6. Check Generator displayed on the Driver Information Center.
7. The transmission shifts hard.

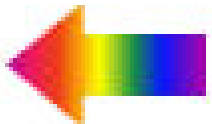



## Service Information (SI) Help Topics

Select a help topic to view:

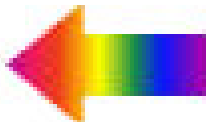

- [Release Note](#)
- [Minimum Requirements to run SI](#)
- [How to zoom on an image \[Plugin Support\]](#)
- [Internet Browser Maintenance](#)
- [Contacting us for Assistance](#)
- [Explanation of Toolbar Icons](#)
- [View current data version](#)

[\[SERVICE INFORMATION HOME\]](#)



Microsoft Internet Explorer window titled "Contacting Us For Assistance - Microsoft Internet Explorer". The address bar shows "http://techline.gm.com/". The page content includes the GM logo and "Service Information" text, followed by a house icon and a question mark icon. The main heading is "Contacting Us For Assistance". The text reads: "If you need assistance with the Service Information (SI) application, contact the Techline Customer Support Center (TCSC):". Under "United States", the phone numbers are "1-888-337-1010 prompt 3" and "1-248-265-9327 (Fax)". A link to "http://techline.gm.com" is provided. Under "Canada", the phone numbers are "1-800-828-6860 (English)" and "1-800-503-3222 (French)". Under "International", the phone numbers are "001-248-265-2051 (English)", "001-248-265-0439 (French)", "001-248-265-0840 (Spanish)", and "001-248-265-9327 (Fax)". Under "Expertec", the phone number is "1-888-212-8959". The status bar shows "Local intranet".

GM Service Information

## Contacting Us For Assistance

If you need assistance with the Service Information (SI) application, contact the Techline Customer Support Center (TCSC):

United States

1-888-337-1010 prompt 3  
1-248-265-9327 (Fax)

Or visit the Techline web site at <http://techline.gm.com>

Canada

1-800-828-6860 (English)  
1-800-503-3222 (French)

International

001-248-265-2051 (English)  
001-248-265-0439 (French)  
001-248-265-0840 (Spanish)  
001-248-265-9327 (Fax)

Expertec

1-888-212-8959

http://techline.gm.com/ Local intranet

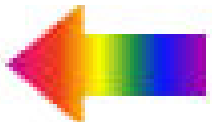

Service Information - Microsoft Internet Explorer

File Edit View Favorites Tools Help

Back Forward Stop Refresh Home Search Favorites History Mail Print

Address  1&booktypeid=2&svc\_cat\_no=21&sec\_id=3&pubpsdid=433&SCT=Driveline%2FAxle&SC=Transfer+Case++BW+4476&msspsdsubkey=3238 Go

 **Service and Parts Operations**

**2004 Cadillac SRX - [Driveline/Axle](#) - Transfer Case - BW 4476**

Match  All or  Any of these words:

Entire Manual  This section only

[Keyword List](#)

Select a category:

- [Specifications](#)
- [Component Locator](#)
- [Repair Instructions](#)
- [Special Tools and Equipment](#)

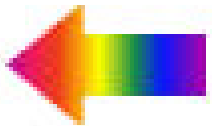

Local intranet





Service Information - Microsoft Internet Explorer





File Edit View Favorites Tools Help

Back Forward Stop Refresh Home Search Favorites History Mail Print

Address  http://127.0.0.1:9001/servlets/SMSCTsrv?bookid=44&booktypeid=9&pubpsdid=518 

 **Service and Parts Operations**

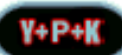
2004 Cadillac SRX

Match  All or  Any of these words:

Select a category:  
[OI Preface](#)  
[Warranty and Owner Assistance Information](#)

[HOME] [PUBLICATIONS]  
[NUMBER SEARCH] [LATEST NEWS] [BULLETIN SEARCH] [HELP]

Done Local intranet

