

# SCOTT®



# CONTOUR

Self-contained Breathing Apparatus

User Instructions

Article No. 1034994

Issue H 05. 2010



CE 0086

# CONTOUR

## Self-contained Breathing Apparatus Contents

<b>WARNINGS</b> .....	<b>ii</b>
<b>1. INTRODUCTION</b> .....	<b>1</b>
1.1 ABBREVIATIONS .....	1
1.2 BREATHABLE AIR .....	1
1.3 COMPRESSED AIR AIRLINE SUPPLIES .....	1
1.4 APPARATUS DURATION .....	2
1.5 TRAINING .....	2
1.6 SERVICING .....	2
1.7 SPARE PARTS AND ACCESSORIES .....	2
1.8 WARRANTY .....	3
1.9 NOTIFIED BODIES .....	3
<b>2. APPARATUS DESCRIPTION</b> .....	<b>3</b>
2.1 GENERAL .....	3
2.2 HARNESS .....	4
2.3 CYLINDER BAND .....	4
2.4 THE PNEUMATIC SYSTEM .....	6
2.5 REDUCER .....	6
2.6 GAUGE AND WHISTLE .....	6
2.7 DEMAND VALVE .....	6
2.8 OPTIONAL ATTACHMENTS .....	7
2.9 FACEMASKS .....	7
<b>3. PRE-USE AND MONTHLY CHECKS</b> .....	<b>8</b>
3.1 CHECK APPARATUS .....	8
3.2 REPLACING CYLINDERS .....	8
3.3 DUO CYLINDER BAND .....	9
3.4 RESET DEMAND VALVE .....	10
3.5 CYLINDER PRESSURE/LEAK TEST .....	10
3.6 DV AND FACEMASK .....	10
3.6.1 All Facemasks .....	10
3.6.2 Facemasks with a Web Harness .....	11
3.6.3 Facemasks with a Net Harness .....	11
3.7 POSITIVE PRESSURE TEST .....	12
3.8 WHISTLE TEST .....	12
3.9 AIRLINE AND DECONTAMINATION ATTACHMENTS .....	12
3.10 RSM ATTACHMENTS .....	13
3.11 HOSES .....	13
<b>4. DONNING PROCEDURE</b> .....	<b>13</b>
4.1 DON APPARATUS .....	13
4.2 CHECK DV/OPEN CYLINDER VALVE .....	14
4.3 DON FACEMASK .....	14
4.3.1 Facemasks with a Web Harness .....	14
4.3.2 Facemasks with a Net Harness .....	14
4.4 POSITIVE PRESSURE TEST .....	15
4.5 FACEMASK SEAL TEST .....	15
4.6 WHISTLE TEST .....	15
4.7 FINAL CHECKS .....	15
4.8 ATTACHING AN AIRLINE .....	16
<b>5. DOFFING INSTRUCTIONS</b> .....	<b>16</b>
5.1 DOFFING THE APPARATUS .....	16
5.2 REMOVE CYLINDER(S) .....	17
<b>6. AFTER USE</b> .....	<b>17</b>
6.1 CLEANING .....	17
6.2 CHECK APPARATUS .....	18
6.3 RECORD TEST DETAILS .....	18
6.4 STORAGE .....	19
<b>7. SCHEDULED MAINTENANCE</b> .....	<b>19</b>
7.1 MONTHLY .....	19
7.2 ANNUALLY .....	19

Registered Office: Scott Health and Safety Limited, Pimbo Road, West Pimbo,  
Skelmersdale, Lancashire, WN8 9RA, England.

## WARNINGS

### Please Read Carefully and Fully Understand

This manual is for use by personnel trained in the use and care of compressed air breathing apparatus, and **MUST NOT** be used as a self-teaching guide by untrained users. Failure to understand or adhere to the **Contour** user instructions may result in injury or death.

**Scott Health and Safety Limited** has taken great care to ensure that the information in this manual is accurate, complete and clear. However, **Training and Technical Support Services** will be pleased to clarify any points in the manual and answer questions on **SCOTT** breathing apparatus.

The following warnings are in accordance with certifying authority requirements and apply to the use of breathing apparatus in general:



Breathing apparatus users must be fully trained in the use and care of self-contained, compressed air breathing apparatus.



Ensure that the selection of the apparatus type is sufficient for the tasks being undertaken and the hazards likely to be encountered. Please refer to National Regulations for guidance.



Adequate protection may not be provided in certain highly toxic atmospheres.



The apparatus must be tested and serviced in accordance with Section 7 - *Scheduled Maintenance* and the notes in Section 1 under *Training and Servicing*.



The quality of air used to supply and charge breathing apparatus must meet the requirements of EN 12021 : 1999 or AS/NZS1715 : 1994. See Section 1 for details.



In Australia and New Zealand, ensure that your selection of respiratory protective devices conform to the requirements of AS/NZS1715 : 1994.



Ensure that a good seal can be obtained between the face and facemask. The wearing of beards, side-burns or spectacles may adversely affect the sealing of a facemask to the wearer's face.



The apparatus is not designed for use underwater.



The harness must not be used as a vehicle seat restraint.

#### DISCLAIMER

Failure to comply with these instructions or misuse of the apparatus may result in death, injury or material damage, and invalidate any warranty or insurance claims.

#### COPYRIGHT

This manual must not be copied in part or whole, or used for purposes other than its intended purpose without the written permission of **Scott Health and Safety Limited**.

## 1. INTRODUCTION

### 1.1 ABBREVIATIONS

The following abbreviations are used in this manual:

AL	Airline Attachment
BA	Breathing Apparatus
CVR	Cylinder Valve Retainer
DCC	Decontamination Attachment
DV	Demand Valve
HP	High Pressure
IRIS	Integrated Radio Information System
m	Metres
min	Minutes
mg	Milligrams
mm	Millimetres
MP	Medium Pressure
NRV	Non Return Valve
PRV	Pressure Relief Valve
psi	Pounds per Square Inch
RSM	Rescue Mask Attachment

### 1.2 BREATHABLE AIR

Air used to supply or charge breathing air may be natural or synthetic and must comply with EN 12021 : 1999 or AS/NZS1715 : 1994. The composition of breathable air in accordance with EN 12021 is given in *Table 1*.

Component	Mass % (Dry Air)	Volume% (Dry Air)
Oxygen	23.14	20.948
Nitrogen	75.52	78.08
Argon	1.29	0.93
Carbon Dioxide	0.05	0.031 4
Hydrogen	0.000 003	0.000 05
Neon	0.001 270	0.001 818
Helium	0.000 037	0.000 524
Krypton	0.000 330	0.000 114
Xenon	0.000 039	0.000 009

**Table 1: Breathable Air - EN 12021  
(NOT applicable for Australia or  
New Zealand)**

There is an increased fire risk when the oxygen content is above the value shown above.

The purity/quality of air used to supply and charge breathing apparatus should be tested periodically in accordance with national regulations.

Unless otherwise specified, the contaminants shall not exceed the permissible exposure level.

National regulations must be observed.

The mineral oil content shall be such that the air is without the odour of oil. The odour threshold is in the region of 0.3 mg/m<sup>3</sup>.

The water content shall not exceed 50 mg/m<sup>3</sup> for 200 and 207 bar apparatus and 30 mg/m<sup>3</sup> for 300 bar apparatus.

For airline apparatus, air must be used with a dew-point sufficiently low to prevent internal freezing.

### 1.3 COMPRESSED AIR AIRLINE SUPPLIES

Air for use with compressed air airlines must conform to EN 12021 : 1999 or AS/NZS1715 : 1994 and must have a dew point sufficiently low to prevent internal freezing when apparatus is used in temperatures below 4°C.

No. of Wearers	Airflow (L/min.)
1	300
2	450
3	750
4	900

**Table 2**

Airline pressure must be between 5.0 and 9.0 bar (70 and 130 psi). Airflow supply capacity for a single airline is given in *Table 2*.

Generally; each additional wearer requires an extra 150 litres per minute, each additional pair of wearers requires 300 L/min for one wearer and 450 L/min for two wearers. All measurements must be taken at the wearer end of the airline.

**Example:** for 8 users (4 pairs) the recommended flow is  $4 \times (300 + 150) = 1800$  litres/minute.

# CONTOUR

---

An airline flow tester is available from **Scott Health and Safety Limited** under Article Number 1035978.

Compressed air airlines used with **Contour** must be **SCOTT** products, approved to EN 139 or AS/NZS1716 : 2003.

Ensure that hoses used in an explosive or flammable atmosphere are marked:  
ANTI-STATIC  
EN 139  
AS/NZS1716  
BREATHING AIR

Cost effective PVC hoses may be used in other atmospheres.

**Scott Health and Safety Limited** manufacture a range of anti-static and PVC hoses, in lengths ranging from 15m to 60m. Our **Customer Services** Department will be pleased to provide details on price and delivery.

## 1.4 APPARATUS DURATION

All durations quoted are nominal, based on an Average Wearer Consumption Rate of 40 L/min and FULLY CHARGED cylinders. Actual Wearer Consumption rates vary due to many factors, such as:

- Workload: high work rates increase consumption rates.
- Weight of apparatus and use of heavy or restrictive clothing.
- Work environments with extremes of heat or cold.
- Physical fitness of the wearer.
- Other factors include emotional stress and fatigue.
- Supplying cylinder air to a resuscitator or rescue second mask (RSM).

It is important that all wearers are aware of these factors and take account of them when assessing cylinder duration.

## 1.5 TRAINING

Personnel who use self-contained, compressed air breathing apparatus must be fully trained in accordance with these instructions and national regulations.

These instructions cannot replace an accredited training course run by fully qualified instructors in the proper and safe use of **SCOTT** breathing apparatus.

Please contact **Training and Technical Support Services** or your distributor for training course details.

## 1.6 SERVICING

**Contour** must be serviced at scheduled intervals by personnel who have completed a formal training course and hold a current certificate for the servicing and repair of **SCOTT** breathing apparatus. Details of the servicing schedule are contained in the **SCOTT Contour** Service Manual, copies of which can only be obtained by registered holders of a current certificate.

Your distributor or **Training and Technical Support Services** will be pleased to provide training course details and quotes for service contracts. Please see above for contact details.

## 1.7 SPARE PARTS AND ACCESSORIES

**Customer Services** provide an efficient, friendly, customer contact point for ordering new apparatus, spare parts and accessories. The team can also provide general information on **SCOTT** products.

## 1.8 WARRANTY

The products manufactured at our factories in Skelmersdale and Vaasa carry a warranty of 12 months (unless stated otherwise) for parts, labour and return to site. The warranty period runs from the date of purchase by the end user.

These products are warranted to be free from defects in materials and workmanship at the time of delivery. **SCOTT** will be under no liability for any defect arising from wilful damage, negligence, abnormal working conditions, failure to follow the original manufacturer's instructions, misuse or unauthorised alteration or repair.

Evidence of purchase date will need to be provided for any claims arising during the warranty period. All warranty claims must be directed through **SCOTT Customer Services** and in accordance with our sales return procedure.

## 1.9 NOTIFIED BODIES

Inspec International Limited (0194)  
56 Leslie Hough Way,  
Salford,  
Greater Manchester,  
M6 6AJ,  
England.

BSI Product Services (0086)  
Kitemark House,  
Maylands Avenue,  
Hemel Hempstead,  
HP2 4SQ,  
England.

SAI Global  
286 Sussex Street,  
Sydney,  
NSW 2000,  
Australia.  
Lic. No 1214.

## 2. APPARATUS DESCRIPTION

### 2.1 GENERAL

**Contour** is an open circuit, self-contained compressed air Breathing Apparatus (BA) for use by fire-fighters and in industrial applications, where a high level of respiratory protection is required.

Standard versions of **Contour** feature a mechanical pressure gauge and whistle mounted on the left-hand shoulder strap. Versions specifically intended for use by fire-fighters are available which incorporate the **IRIS** data-communications system.

All safety-critical components on the **Contour** Set, (for example the reducer valve and demand valve etc), are individually identified by a unique serial number and date of manufacture.

**Contour** is approved to European Standards EN 137 : 1993, EN 137 : 2006 Class 1 (self-contained breathing apparatus) and EN 139 : 1995 (self-contained breathing apparatus with airline attachment). **Contour** is 'CE' marked in accordance with EC Directive EC/686/1986.

**Contour** is approved to Australian/New Zealand Standard AS/NZS1716 : 2003.

**Contour** is also approved for use at sea by:

**Lloyds Inspectorate**, in accordance with SOLAS regulation 17 and the 1980 Merchant Shipping Act.

Please call **Scott Health and Safety Limited** for further apparatus approval details.

This manual contains user instructions for single cylinder, twin cylinder (**Duo**) versions, and versions for use with compressed air airlines. **Duo** models are not normally provided with airline attachments.

# CONTOUR

**Contour** is marked in accordance with EN 137 : 2003 and AS/NZS1716 : 2003. An explanation of those markings is given below:

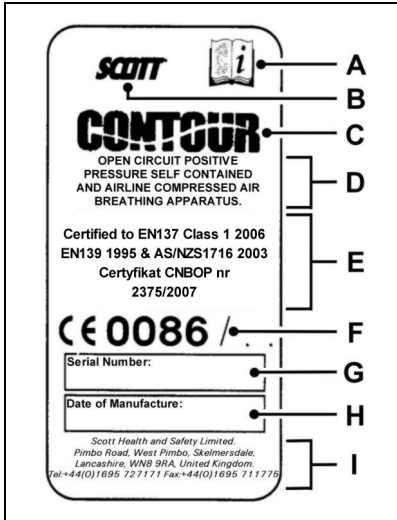

Key	Meaning
A =	Symbol - refer to User Instructions
B =	Product brand name
C =	Product model/designation
D =	Apparatus description
E =	Standards to which apparatus is certified
F =	Number of Approval Body
G =	Serial number of apparatus
H =	Date of manufacture
I =	Contact details of manufacturer

## 2.2 HARNESS

**Contour** is available with a flame-retardant polyamide/ polyester or a **Kevlar™/Nomex™** harness (identified by a **-K** in the unit part number). Buckles are of black nylon or stainless steel. Press-studs are of brass or nickel plated brass.

On **Kevlar™** versions the pneumatics and hoses are attached to the harness by loops closed by press-studs. On EN versions the loops do not open.

For wearer comfort, a lumbar pad (fitted as standard), or a full back pad (fitted as an option) is provided. Both are fabricated from flame-retardant material and packed with flame retardant, closed cell foam. The lumbar pad is held in place by four press-studs. The full length pad is held by press studs and the harness straps.

A chest-strap is available as an option.

## 2.3 CYLINDER BAND

**Contour** can be configured for use with one or two (**Duo**), 200, 207 or 300 bar, steel or fully wrapped aluminium carbon fibre composite cylinders (see *Table 3*).

Cylinders are secured to the light-weight back-plate by a webbing cylinder band and a cylinder valve retainer (CVR). A conversion kit is available for converting single cylinder apparatus to **Duo**.

The webbing cylinder band is closed by a cam lock buckle with a latch that prevents accidental opening. The band can be adjusted to accept the range of cylinders listed in *Table 3*. The cam-lock buckle facilitates replacement of similar size cylinders without cylinder band adjustment.

**Contour Duo** cylinder bands can be easily altered by the wearer (no tools required) to mount a single cylinder, centrally on the back-plate.

Cylinders	Water Capacity (litres)	Charging Pressure (bar)	Free air Volume (litres)	Nominal Duration (mins)	Warning Period (mins)	Total Duration (mins)	Cylinder Charged Weight (kg)	Weight of Contour with Cylinder (kg)	
								Single	Duo
CYL-1200	6.0	200	1200	22	8	30	8.8	11.8	-
CYL-HWG-1200	6.0	207	1200	22	8	30	7.2	10.2	-
CYL-FWC-1300	4.7	300	1300	25	7	32	5.0	8.0	-
CYL-1640	6.0	300	1640	33	8	41	12.5	15.5	-
CYL-HWG-1640	6.0	300	1640	33	8	41	10.0	13.0	-
CYL-FWC-1640	6.0	300	1640	33	8	41	6.3	9.3	15.6
CYL-1800	9.0	200	1800	33	12	45	13.0	16.0	-
CYL-HWG-1800	9.0	207	1800	33	12	45	11.2	14.2	-
CYL-FWC-1800	9.0	207	1800	33	12	45	6.75	9.75	16.5
CYL-FWC-1860	6.8	300	1860	37	9	46	6.75	9.75	16.5
CYL-FWC-2460	9.0	300	2460	50	12	62	8.8	11.8	-

**Note:**

Only cylinders in shaded areas are suitable for use with **Contour Duo** in twin cylinder configuration. The total apparatus weight must not exceed 18 kg when fully-charged; (ref: EN 137, Clause 5.4 and AS/NZS1716 : 2003).

**Table 3: Cylinders approved for use with Contour apparatus**

Table 4 identifies the cylinder material code and the cylinder specification.

Code	Material	Specification
No Code	Steel (e.g.: CYL-1200)	CE Marked (EU) Work Cover (Australia & New Zealand)
HWG	Hoop Wrapped Glass Fibre (e.g.: CYL-HWG-1200)	HSE-AL-HW1 (EU) Work Cover (Australia & New Zealand)
FWC	Fully Wrapped Carbon (e.g.: CYL-FWC-1300)	CE Marked (EU) Work Cover (Australia & New Zealand)

**Table 4: Cylinder Codes and Specifications**

Durations are nominal and based on an Average Wearer Consumption Rate of 40 L/min and are for **fully charged cylinders**.

$$\text{Total Duration} = \frac{\text{Cylinder Free Air Capacity}}{\text{Average Wearer Consumption Rate}}$$

$$\text{Nominal Duration} = \text{Total Duration minus the Warning Period.}$$

$$\text{Warning Period} = \frac{\text{Whistle Operating Pressure}}{\text{Average Wearer Consumption Rate}}$$



# CONTOUR

## 2.4 THE PNEUMATIC SYSTEM

The pneumatic system has two pressure reduction stages: air from the cylinder is reduced to a medium-pressure (MP) of between 5.5 and 11 bar by the reducer. The second pressure reduction is performed in the facemask Demand Valve (DV).

Air from the cylinder passes through a sintered bronze particle filter in the cylinder connector, which protects the pneumatic system, then through a short length of High Pressure (HP) braided hose to the reducer inlet manifold.

## 2.5 REDUCER

The reducer is a simple, self-regulating, spring and piston device, which requires no adjustment. It has a pressure relief valve (PRV) that protects the MP system from over-pressurisation.

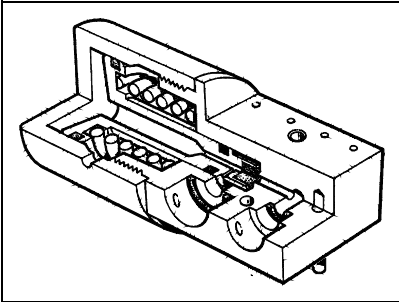

Air from the reducer is connected through a reinforced chlorinated polyethylene hose to the facemask-mounted DV, which regulates the air supplied to the wearer.

## 2.6 GAUGE AND WHISTLE

A high-pressure hose from the reducer inlet manifold connects air, at cylinder pressure, to a warning whistle and pressure gauge mounted on the **Contour** shoulder strap.

On standard versions, the warning whistle and pressure gauge are mounted on the left-hand shoulder strap.

On versions fitted with the **IRIS** data-communications system, the warning whistle and pressure gauge are incorporated within the **IRIS** unit.

The warning whistle sounds when pressure in the cylinder falls to 55 bar ( $\pm 5$  bar).

The duration of the air remaining in the cylinder, from the start of the warning whistle, is listed for each cylinder type under *Warning Period* in Table 3.

The pressure gauge dial is photo luminescent to aid use in low light levels. The lens is impact resistant polycarbonate. A rubber shroud protects the gauge.

Should the gauge, whistle or hose become damaged, a restrictor in the reducer limits air-loss to less than 25 litres per minute.

## 2.7 DEMAND VALVE

The DV operates in conjunction with the facemask spring-loaded exhale valve to maintain a positive pressure within the facemask.

The DV has a servo-assisted tilting diaphragm mechanism that responds to pressure changes within the facemask to regulate the flow of air to the mask, ensuring that pressure within the mask remains safely above ambient.

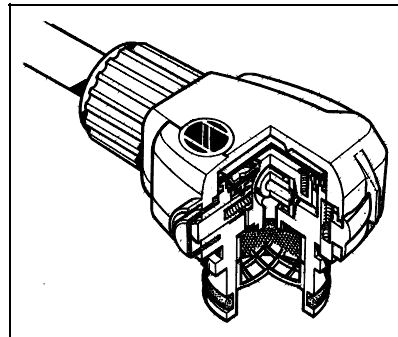

The DV has a reset button that enables wearers to close the air-flow through the DV, allowing the facemask to be removed during test procedures and at the end of a task without loss of cylinder air.

When the apparatus is donned the DV is normally "reset" (closed), and is opened (activated) when the wearer takes a first breath.

The DV has a supplementary flow device (bypass), that the wearer can open using the bypass knob.

When the bypass is used the unregulated flow of air through the DV reduces cylinder duration.

The DV is connected to the facemask by a Quick-Fit (QF) bayonet fitting with a spring-loaded locking catch to prevent accidental disconnection.

## 2.8 OPTIONAL ATTACHMENTS

The options available are:

- Decontamination attachment (DCC) - facilitates airline connection into a gas-tight chemical suit, permitting the wearer to breathe from an airline during extended decontamination procedures.
- Rescue mask attachment (RSM) - permits the wearer to supply a rescue mask or an air powered resuscitator from own cylinder air. This reduces the duration of the cylinder supply.
- Airline attachment (AL) - permits **Contour** to be used with an airline. The cylinder provides emergency backup.

### Note:

Air for use with airlines must conform to *Breathable Air* as detailed in *Section 1*.

## 2.9 FACEMASKS

**Contour** is approved for use with: **Vision 3**, **PanaSeal**, **PanaVisor** and **Promask PP** full facemasks, all of which conform to EN 136, Class 3 and AS/NZS1716 : 2003.

All are available with five point, fully adjustable web or net head-harnesses and neck-straps.

An inner mask minimises CO<sub>2</sub> dead space and visor misting. A speech diaphragm is fitted.

**PanaSeal** is suitable for medium and smaller face sizes; **PanaVisor** is suitable for medium to larger face sizes. **Vision 3** is available in three sizes: small, medium and medium/large which cover most face sizes. **Promask PP** is available in two sizes: small/medium and medium/large.

**Vision 3** is moulded in grey silicone, while **PanaSeal** and **PanaVisor** are of non-dermatitic, black neoprene or blue silicone. **Promask PP** is moulded in hypo-allergenic, black **Procomp**<sup>™</sup> with a soft silicone inner mask.

The polycarbonate visors conform to EN 166 Grade B for medium impact-resistance and AS/NZS 1337 : 1992 for high-impact resistance.

Versions of the above masks are also available with helmet attachment clamps fitted. Please contact **Customer Services** for further information.



**Vision 3 Facemask with Web Harness**



**PanaSeal/PanaVisor Facemask with Net Harness**



Promask PP Facemask

## 3. PRE-USE AND MONTHLY CHECKS

### 3.1 CHECK APPARATUS



**Contour** must be clean and in good condition. Check that all hose retaining press-studs (if fitted) are closed. Fully slacken the waist-belt and shoulder straps ready for use.

### 3.2 REPLACING CYLINDERS

#### WARNING:

**On Duo models, always fit matching, fully-charged cylinders.**

1. Close the cylinder valve (on Duo Sets, close both cylinder valves).
2. Open the facemask bypass to vent the system.
3. Undo the cylinder connector(s).



4. Grasp and pull the edges of the cam-lock buckle with index finger and thumb of the left hand and use the right index finger to slide the ribbed, release catch. Pull the cam-lock fully open.

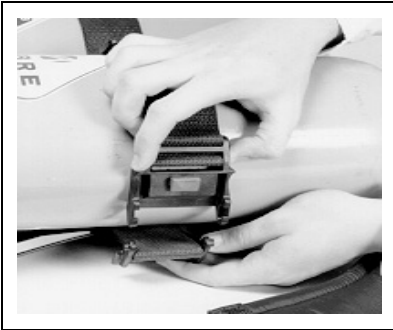

5. Open the buckle and remove the cylinder(s).
6. Place fully charged cylinder(s) on the back-plate with the cylinder outlet(s) through the cylinder valve retainer(s).



7. On **Duo**, ensure that the dividing loop is between the cylinders.

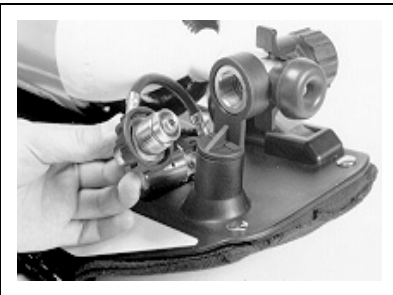

8. Check that the cylinder hand-wheel connector O-ring(s) is (are) clean and in good condition and screw the connector

firmly onto the cylinder valve (onto the **Duo** manifold).

**Note:**

In some instances it may be necessary to adjust the size of the cylinder band. To do this:

- i) Engage the buckle hinge, but do not close the cam-lock.
- ii) Tighten the cylinder band using the slide buckle, until the band holds the cylinder securely.
- iii) Close the cam-lock buckle.

When **Contour** is used with an airline check that:

- i) The airline is in good condition, free from splits, bulges and abrasions.
- ii) The airline connector is in good condition and that it connects securely to the **Contour** pigtail.
- iii) The air supply conforms to EN 12021 or AS/NZS1715 : 1994 (see *Section 1.3 - Compressed Airline Supplies*).
- iv) The **Contour** airline coupling is in good condition.

### 3.3 DUO CYLINDER BAND

The **Duo** cylinder band can be adapted to hold two or one cylinder.

In normal use, the dividing loop passes between the two cylinders, to separate and secure them. By flattening the dividing loop against the cylinder band wearers can configure **Duo** for single cylinder operation.

To alter the **Duo** cylinder band to hold only one cylinder:

1. Slide the dividing loop so that it is next to the back-plate and lying flat on the cylinder band.

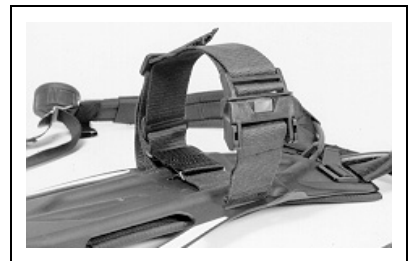

# CONTOUR

2. Shorten the cylinder band by feeding the excess length through the buckles on the band.

## 3.4 RESET DEMAND VALVE



1. Press the black rubber reset button on the side of the DV and check that the red bypass knob is turned so that the flat on the bypass knob aligns with the DV outlet.

2. Check that the orange O-ring on the DV outlet is clean and in good condition.

## 3.5 CYLINDER PRESSURE/ LEAK TEST



1. Slowly open cylinder valve fully (on **Duo** Sets open only one cylinder valve) and allow 10 seconds for the apparatus to pressurise.

2. Check that the pressure gauge shows the cylinder is at least 80% FULL (240 bar for 300 bar cylinders, 170 bar for 200 and 207 bar cylinders). Listen for leaks.

3. Close the cylinder valve and monitor the pressure gauge for one minute. If the reading falls by more than 10 bar during this time there is an unacceptable leak.

4. On **Duo** Sets, close the first cylinder valve, vent the apparatus by opening the DV bypass and repeat the test using the second cylinder.

5. If the system fails the leak test: close the cylinder valve, vent air from the system by opening the DV bypass. Check all pneumatic connections and repeat the leak test.

6. **DO NOT USE** apparatus that leaks excessively. Attach an explanatory note and return the apparatus for service.

## 3.6 DV AND FACEMASK

### 3.6.1 All Facemasks

1. Check that the facemask is clean and undamaged.



2. Check that the orange O-ring on the DV outlet is clean and in good condition.



3. Fit the DV to the facemask and check that the red locking catch engages fully. Twist the DV gently to confirm that it has.
4. Open the cylinder valve(s) fully.

### 3.6.2 Facemasks with a Web Harness

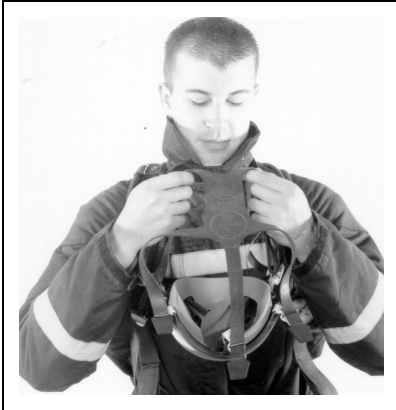

1. Hold the head-harness lower straps, place chin in chin-cup and pull straps over back of head, brushing back hair from under face-seal.



2. Tighten harness straps in sequence: **Bottom, Middle, Top**. DO NOT over-tighten.
3. Inhale deeply and check that the DV first breath mechanism operates.

### 3.6.3 Facemasks with a Net Harness

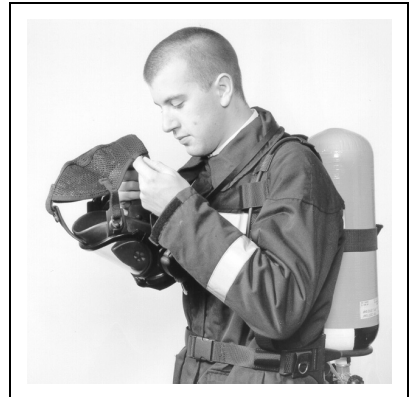

1. Hold the mask by the side of the net harness, place the chin into the chin-cup and pull the mask onto the face. Grasp the pull-strap at the rear of the net harness and pull the net over the head.



2. Tighten harness side straps. DO NOT over-tighten.
3. Inhale deeply and check that the DV first breath mechanism operates.

# CONTOUR

## 3.7 POSITIVE PRESSURE TEST



1. With the cylinder valve open, insert a finger under face-seal and check for a steady outward flow of air. Remove finger and allow mask to re-seal.
2. Hold breath for ten seconds and listen for leaks. If there are leaks, loosen the head-harness and adjust the mask for a comfortable leak tight fit and repeat test. DO NOT over-tighten the head-harness.
3. DO NOT USE apparatus that leaks. Attach an explanatory note and return for servicing.
4. When satisfied with the apparatus, press the DV reset knob, remove the facemask and close the cylinder valve.

## 3.8 WHISTLE TEST



1. With the cylinder valve(s) closed, open the bypass knob briefly to vent air from the system.
2. Check that the whistle sounds clearly as the pressure gauge falls below 55 bar ( $\pm 5$  bar).
3. The apparatus is now fully tested and may be stored prior to use.

### Note:

Other warning whistle pressures may be selected at purchase: 55 bar whistles (green spot), 44 bar (red) and 68 bar (yellow).

## 3.9 AIRLINE AND DECONTAMINATION ATTACHMENTS

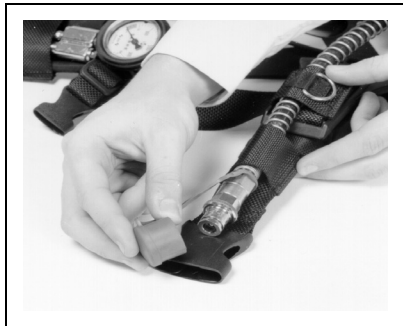

1. Check the supply airline flow and pressure. Remove connector dust caps and check for wear and damage.
2. Make connection to an appropriate connector capable of supplying breathable compressed air (see *Section 1.3 - Compressed Air Airline Supplies*).
3. Check that the connection is secure and that the connector releases easily, without sticking.
4. Press the DV reset button.
5. Pressurise the attachment and check all connections for leaks. On airline attachments, check that the female connector does not leak.
6. DO NOT use attachments that show signs of excessive wear or damage, or that leak excessively.
7. Replace dust caps.

### 3.10 RSM ATTACHMENTS

1. Remove RSM dust caps and attach a rescue mask to the RSM attachment.
2. Press the DV reset buttons on the wearer facemask and rescue mask.
3. Open the **Contour** cylinder valve and check that the RSM connection does not leak.
4. Don the rescue mask, inhale sharply to activate the first breath mechanism and check that there is a plentiful supply of air.
5. Disconnect the rescue mask and check once again that the RSM connector does not leak.
6. Replace dust caps.
7. DO NOT use attachments that show signs of excessive wear or damage, or that leak excessively.

### 3.11 HOSES

1. Check all hoses for damage and excess wear. Flex hoses to reveal any splits, cracks or crazing (minor crazing is acceptable).
2. Check couplings for damage and excess wear; and ensure that they can be opened.
3. When closed, check that they form a secure coupling.
4. Replace damaged or worn hoses.

## 4. DONNING PROCEDURE

### 4.1 DON APPARATUS

**Note:**

Specialist Users, (such as Emergency Services) may operate alternative donning procedures, which conform to the relevant statutory regulations and have been approved by **Scott Health and Safety Limited**.

1. Check that the **Contour** and facemask harnesses are fully slackened and that the DV is connected to the facemask.
2. Hang the facemask round the neck by its neck-strap.
3. Pass the right arm through the shoulder strap and swing the harness across the back and slip the left arm through the shoulder strap.

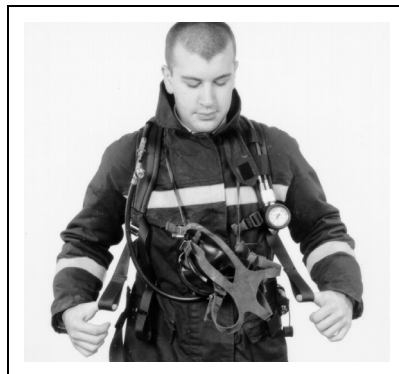

4. Pull down on the shoulder strap ends until the apparatus fits comfortably then close the waist-belt.

**Note:**

If the waist-belt is closed first, tightening the shoulder straps will pull up the waist-belt, causing discomfort.



# CONTOUR

## 4.2 CHECK DV/OPEN CYLINDER VALVE



1. Check that the flat on the DV bypass knob aligns with the DV outlet and press the black reset button.
2. Open the cylinder valve slowly with your right hand, whilst holding the pressure gauge in your left (on **Duo Sets** open only one cylinder valve) and check that the pressure gauge reads 80% FULL (170 bar for 200 and 207 bar cylinders and 240 bar for 300 bar cylinders).

### WARNING:

When opening cylinder valve, **DO NOT** use the high-pressure hose as leverage.

## 4.3 DON FACEMASK

### 4.3.1 Facemasks with a Web Harness



1. Hold the head-harness lower straps, place chin in chin-cup and pull straps over back of head, brushing hair away from face-seal.



2. Adjust the facemask top strap so that the mask is at the correct level with the face and the head-harness pad is in the centre of the back of the head and then tighten harness straps in sequence: **Bottom, Middle, Top**. **DO NOT** over-tighten.
3. Inhale deeply to activate the DV then breathe normally.

### 4.3.2 Facemasks with a Net Harness

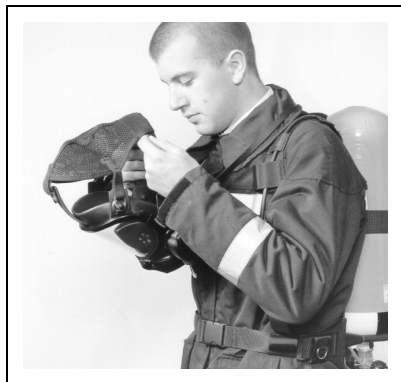

1. Hold the mask by the side of the net harness, place the chin into the chin-cup and pull the mask onto the face. Grasp the pull-strap at the rear of the net harness and pull the net over the head.



2. Tighten harness side straps. DO NOT over-tighten.
3. Inhale deeply to activate the DV then breathe normally.

## 4.4 POSITIVE PRESSURE TEST



With the cylinder valve open, insert a finger under face-seal and check for a steady outward flow of air. Remove finger and allow mask to re-seal.

## 4.5 FACEMASK SEAL TEST

1. Close the cylinder valve and keep hold of the hand-wheel. Hold breath for 10 seconds and listen carefully for leaks. A leak will cause the pressure gauge reading to fall.
2. If the facemask fails the leak test: open the cylinder valve, loosen the head-harness, adjust the facemask and repeat the test.

## 4.6 WHISTLE TEST

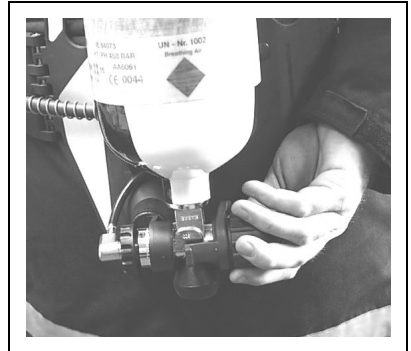

1. With cylinder valve still closed, slowly breathe down the air from the system. Check that the whistle sounds clearly as the pressure gauge falls to 55 bar ( $\pm 5$  bar).
2. Once the whistle has sounded, open the cylinder valve fully.
3. DO NOT USE apparatus that fails this test. Attach an explanatory note and return for service.

## 4.7 FINAL CHECKS

1. Check that the cylinder valve(s) is/are fully open and that the pressure gauge shows that there is sufficient air.

### WARNING:

**On Duo models, BOTH cylinder valves MUST be fully open immediately prior to and during use.**



2. Turn on the DV bypass knob and check for a steady flow of air into the mask. Close the bypass knob.

# CONTOUR

---

## 4.8 ATTACHING AN AIRLINE

### WARNING:

- Airlines should be at least 15 metres long.
- Use anti-static hoses in flammable or explosive atmospheres.

1. Push the airline onto the **Contour** attachment connector.

### WARNING:

**Close cylinder valve while breathing from the airline.**

2. Give the supply airline a firm tug to ensure that it is securely connected.

3. Proceed with tasks to be performed.

## 5. DOFFING INSTRUCTIONS

### 5.1 DOFFING THE APPARATUS

#### WARNING:

- **DO NOT** remove apparatus until well clear of the hazardous area.
- If wearing a gas-tight chemical suit, **DO NOT** remove until decontamination procedures are complete.
- During extended decontamination procedures, connect an airline to the DCC attachment.



1. Hold breath and press the DV reset button.



2. Release the head-harness by pulling the harness buckles forwards. Remove mask and let it hang from the neck strap.

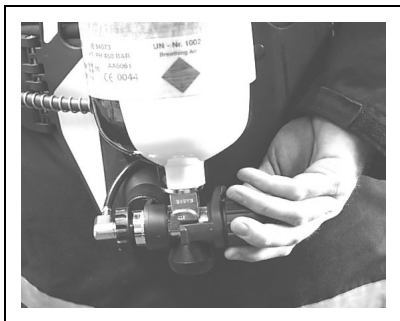

3. Release the hand-wheel locking mechanism and close the cylinder valve(s).
4. Open the DV bypass knob to depressurise the system, then turn the bypass to OFF.



5. Release the waist-belt buckle, slacken shoulder straps by pulling up metal buckles and doff the apparatus.

## 5.2 REMOVE CYLINDER(S)

1. Close the cylinder valve(s) and vent the pneumatics by opening the bypass. Unscrew cylinder valve connector hand-wheel(s).

### CAUTION:

**Ensure air is completely evacuated from the Set before removing the high-pressure hose.**

2. Release cylinder band cam-lock and remove cylinder(s) - (see Section 3 of this Manual). Mark cylinders as empty, store separately from charged cylinders and return for charging.

## 6. AFTER USE

Contour must be cleaned and tested as detailed in the following instructions.

### 6.1 CLEANING

#### CAUTION:

- **DO NOT immerse the DV or warning whistle in water.**
- **USE ONLY the specified methods and materials. DO NOT use bleach, solvent, detergent or abrasive cleaners.**
- **Dry thoroughly, away from direct heat and sunlight, prior to storage.**



1. Disconnect DV from the facemask.
2. Wash and disinfect the mask thoroughly in a solution of **TriGene™** and warm water. See following Note.
3. Rinse the mask thoroughly in clean running water. Pay particular attention to flushing out the exhale valve.
4. Hang mask by its neck-strap and allow it to dry thoroughly away from direct heat or sunlight.
5. When dry, wipe facemask seals with **TriGene™** disinfectant wipes.
6. Polish the visor inside and out with a clean, lint-free cloth and slacken the head-harness, ready for use.

#### Note:

**TriGene™** is available from **Scott Health and Safety Limited** in 1 litre and 5 litre containers under Article Numbers 2008247 and 2008248 respectively.

# CONTOUR

Pump dispensers are available for the above under Article Numbers 1017672 (1 litre) and 1017670 (5 litres).

**TriGene™** disinfecting wipes are available from **Scott Health and Safety Limited** under Article Number 2004225 (pack of 20).

7. The harness can be sponged clean with a mild solution of soap and warm water. Rinse thoroughly and dry in a well ventilated room away from direct heat and sunlight.

8. Fully slacken cylinder band, shoulder straps and waist-belt; and detach the lumbar pad. Release the hose retaining press-studs (if fitted) and separate the pneumatics from the harness.

9. In extreme cases, remove the pneumatics from the harness to gain full access for cleaning. The lumbar pad filling is closed-cell foam that will not absorb water. DO NOT store until completely dry.

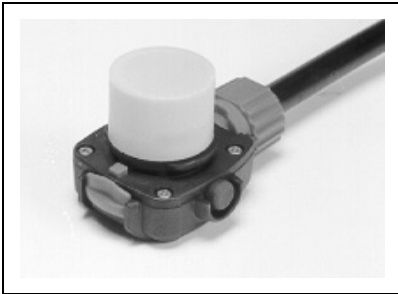

## CAUTION:

**DO NOT immerse the DV.**

10. Fit the yellow cap on the DV outlet.

11. If required use a small brush (e.g. toothbrush) and a mild solution of soap and warm water to clean around the locking catch and bypass knob.

12. Clean the valve body using a lint free cloth moistened in a mild solution of soap and warm water. DO NOT store until completely dry.

## 6.2 CHECK APPARATUS

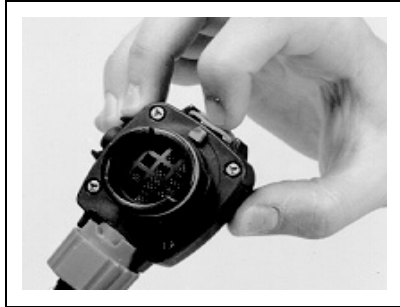

1. Operate the DV locking catch and bypass knob several times and check that they do not stick. If either is not free moving, attach explanatory note and return for servicing.

2. Check that the harness webbing and fittings are not worn or damaged; and that buckles and fastenings are fully operational. Apparatus with major defects must be returned for servicing, with an explanatory label attached.

3. Check **Contour** in accordance with *Section 3 - Pre-Use and Monthly Checks*.

## 6.3 RECORD TEST DETAILS

Record test details in accordance with local regulations within a Breathing Apparatus Logbook (available from **Scott Health and Safety Limited** under Article Number 1034745).

Information recorded usually includes:

- Name and address of employer responsible for the apparatus.
- Make, model number or mark description of any distinguishing features, sufficient to enable clear identification.
- The date of the examination together with the name, signature or unique authentication mark of the examiner.
- The condition of the apparatus and details of any defects found and any remedial action taken, including any airline supply equipment used with the apparatus.
- Cylinder air pressure.

## **6.4 STORAGE**

The apparatus must be stored in a clean, dry environment away from direct heat and sunlight. Storage temperature should not exceed -10°C to +40°C.

## **7. SCHEDULED MAINTENANCE**

### **7.1 MONTHLY**

Test **Contour** in accordance with *Section 3 - Pre-Use and Monthly Checks*.

Record test details in the apparatus' BA Logbook. This record is mandatory in the UK and most EC countries; and must be kept up to date and available for inspection. Please see *Section 6.3* for details.

### **7.2 ANNUALLY**

**Contour** must be returned for a workshop service annually and for a major workshop service at six-yearly intervals.

After each workshop service, perform the user checks detailed in *Section 3 - Pre-Use and Monthly Checks* prior to returning **Contour** to service.

Check that workshop service details have been recorded in the apparatus' BA Log.



Thank you for reading this data sheet.

For pricing or for further information, please contact us at our UK Office, using the details below.



**UK Office**

**Keison Products,**

**P.O. Box 2124, Chelmsford, Essex, CM1 3UP, England.**

**Tel: +44 (0)1245 600560**

**Fax: +44 (0)1245 808399**

**Email: [sales@keison.co.uk](mailto:sales@keison.co.uk)**

Please note - Product designs and specifications are subject to change without notice. The user is responsible for determining the suitability of this product.