SERVICE MANUAL



TVL-151M

TVL-201M

- Contents -

1. Detail Specification
 - 1-1. PANEL
 - 1-2. IN/OUT JACK
 - 1-3. User Interface Specification
 - 1-4. Electrical Specification
 - 1-5. Available PC Input Mode & Video Timing Standard
 - 1-6. OSD Specification (America)
 - 1-7. OSD Specification (***)
 - 1-8. Factory mode OSD Specification
 2. Adjustment Specification
 - 2-1. Adjustment of CLOCK DELAY
 - 2-2. Adjustment of AUTO COLOR GAIN
 - 2-3. Setting Instruction of OPTION
 - 2-4. Adjustment Instruction of VPC3230
 3. Inspection Specification
 - 3-1. Inspection of LCD PANEL
 - 3-2. Inspection of INVERTOR
 - 3-3. Inspection of ASSY-CONTROL
 - 3-4. Inspection of ASSY-MAIN
 4. Block Diagram
 5. Circuit Diagram
 6. General Specification
 7. Troubleshooting
 8. Parts List
 9. Main PCB Drawing
-

1. Detail Specification

1-1. LCD Panel

LG-Philips LCD Panel : LC151X01-A3 : 15.1"(Panel Link Type)
LC201V1-A3 : 20.1"

1-2. In/Out Jack

Power Supply Input : Din Jack
Antenna Input : 75ohm Unbalanced Din-Jack Type
PC Input : 15pin D-sub Jack (Female Type)
PC Audio Input : Phone Jack (Stereo Type)
Composite Video In : RCA Jack
DVD In : RCA Jack (Y, Cb, Cr) - * 20.1" Model Only
S-Video In
Audio Input : RCA Jack (When Composite or S-Video input)
EURO SCART Jack
Head-Phone Output Jack : Phone Jack (When the Jack insert, Main Sound is mute.)
Audio Out : RCA Jack (Monitor Out)
Video Out : RCA Jack (Monitor Out)

1-3. User Interface

7 Panel Key

Power , Menu , Select , Vol Up , Vol Down , CH Up , CH Down

3 Color LED

Red : Stand by Condition

Green : Power On Condition

Scarlet : SLEEP TIME On Condition

Green Blink : When the PC Mode, Inserted D-sub Jack but
H,V Sync is not input or PC Power Save Mode

Remocon Receiver

Remocon (Pal ; 41Key, NTSC ; 29Key)

On Screen Display

Control using OSD

OSD Language : English, German, Italian etc.

Plug & Play : DDC - 1/2B

Factory Mode

Mode for controlling the adjustment item & Panel Option in mass production

1-4. Electrical Specification

TV Color Standard : PAL,SECAM (NTSC System : NTSC)

TV Sound Standard : B/G,I,D/K (NTSC System : M)

TV Stereo Sound : NICAM Stereo , A2 Stereo (NTSC System : BTSC)

TV Receiving Range : VHF LOW(2 ~ H), VHF-HIGH(I ~ W+26),
UHF (W+27~78)

Total 100CH (NTSC System : 181CH)

Sound Output : RMS 1.5W X 2CH

Power Supply : AC / DC Adaptor (DC12V , 5A , 50 /60 HZ)

Input Power : AC 100V ~ 265V

Power Consumption : Stand-by : 3W , Power On : 45W

Video Input Level : 1 Vp_p , 75 ohm

Audio Input Level : 500mVrms

PC Input Level : Analog RGB Input (H,V Separator)

See 1-5. Available PC Input Mode & Video Timing Standard.

Audio Output Level : 500mVrms

Head-Phone Output Level : 100mW

SERVICE MANUAL

TVL-151M / 201M

1-5. Available PC Input Mode & Video Timing Standard

	Resolution		Horizontal		Vertical		Clock	Time	Remarks
	H	V	(KHz)	Pol.	(Hz)	Pol.	(MHz)	(nsec)	
IBM	640	350	31.469	P	70.087	N	25.175	39.722	VGA
IBM	640	480	31.469	N	59.940	N	25.175	39.722	
VESA	640	480	37.861	N	72.809	N	31.500	31.746	
VESA	640	480	37.500	N	75.000	N	31.500	31.746	
VESA	640	480	43.269	N	85.008	N	36.000	27.778	
IBM	720	400	31.465	N	70.087	P	28.322	35.308	
VESA	800	600	31.156	N/P	56.250	N/P	36.000	27.778	SVGA
VESA	800	600	37.879	P	60.317	P	40.000	25.000	
VESA	800	600	48.077	P	72.188	P	50.000	20.000	
VESA	800	600	48.875	P	75.000	P	49.500	20.202	
VESA	800	600	53.674	P	85.061	P	56.250	17.778	
VESA	1024	768	48.363	N	60.004	N	65.000	15.358	XGA
VESA	1024	768	56.476	N	70.069	N	75.000	13.333	
VESA	1024	768	60.023	P	75.029	P	78.750	12.698	
VESA	1024	768	68.677	P	84.997	P	94.500	10.582	

1-6. OSD Specification

PICTURE

CONTRAST

BRIGHTNESS

COLOR TEMPERAT (PC input mode only)

STANDARD , 6500K , USER, RESET , 9300K

SHARPNESS (Not Available PC MODE)

COLOR (Not Available PC MODE)

TINT (NTSC System Only)

SOUND

BASS

TREBLE

BALANCE

MTS (S.MODE)

GEOMETRY (PC input mode only)

H-POSITION

V-POSITION

AUTO POSITION

FUNCTION

TRACKING (PC input mode only)

AUTO TRACKING

CLOCK

PHASE

INFORMATION

TUNING (TV input mode only)

SORT

AUTO TUNING

MANUAL TUNING

FINE TUNING

CH SKIP

LANGUAGE (PAL/SECAM System)

CAPTION (NTSC System)

V-CHIP (NTSC System)

1-8. Factory Mode OSD Specification

How to use Factory Mode

Press Power & Select Key in Panel Control key, and go to Factory mode.

Factory ADJ

CLOCK DELAY

AUTO COLOR GAIN

OPTION

TTX LOCAL

TTX E/W

MX88L281 1

AD9884 1 (PC input mode only)

AD9884 2 (PC input mode only)

SUB C VCP

SUB C CHG CURRENT

INIT VCO CURRENT

VPC3230 (excluding PC MODE)

CONTRAST

BRIGHTNESS

PEAKING

CIP CONTRAST

CIP BRIGHT

** In mass production, adjust only Factory ADJ item, do not adjust other Modes.

(In the time of variation of A/S & initial condition of screen quality , built in other Modes for controlling)

2. Adjustment Instruction (Factory ADJ)

2-1. Adjustment instruction of CLOCK DELAY

1. Adjustment item : Adjust the dispersion happening in the time of matching ASSY-MAIN and LCD PANEL .
(As the contact status of the CONNCETOR for connecting LCD PANEL, dispersion happens)
2. Adjustment Process : After assembling the SET , do the adjustment.
3. Preliminary adjustment :
 - 1) Connect the outlet VIDEO PATTERN GENERATOR (ANALOG RGB & SEPARATE H,V OUT) to INPUT
(15PIN D-sub with VGA CABLE)
 - 2) TEST PATTERN: 1DOT BLACK, Select WHITE PATTERN.
(In the case of the tool of MSPG-925L, select PATTERN NO.28)
 - 3) Select Output FORMAT into 1024 x 768 @85HZ. (Select MODEL : 21)
 - 4) Turn on the SET, and them select in PC MODE.
4. Adjustment Instruction :
 - 1) Press SEL & Power Key in Front panel at the same time , go to Factory mode
 - 2) Select CLOCK DELAY (including in FACTORY ADJ MENU) with CH UP/DOWN KEY in Factory mode
 - 3) Changing the level of CLOCK DELAY with VOL UP/DOWN KEY, adjust to the noiseless level in screen
(variable range : 0 ~ 15, DEFAULT : 15)

2-2. Adjustment Instruction of AUTO COLOR GAIN

1. Adjustment Item : Function of automatically setting ADC LEVEL of AD9884 with ANALOG RGB (D-sub) signal .
(WHITE BALANCE & CONTRAST adjustment)
2. Adjustment Process : After assembling the SET , do the adjustment .
3. Preliminary Adjustment
 - : 1) Connect Outlet of VIDEO PATTERN GENERATOR to the input terminal of CVBS.
 - 2) TEST PATTERN : Select COLOR BAR PATTERN
 - 3) Turn on the SET, and then select in VIDEO MODE.
4. Adjustment Instruction
 - : 1) Press SEL & Power Key in Front Panel at the same time, and go to Factory mode.
 - 2) In Factory mode, select Auto Color Gain in Factory ADJ.
 - 3) Press VOL UP KEY , and then displaying the phrase " Processing " , AUTO Adjustment start
 - 4) When adjustment is completed , the phrase " Processing " disappears
=> caution : In the course of Processing, do not remove the signal.

2-3. Setting Instruction for OPTION

1. OPTION : - X2 - BYPASS
 - => Using 6 BIT PANEL
 - => Back-Light Control of Inverter
(Bright Max : LOW , Min : HIGH)

2. OPTION : - X2 - INVERT
 - => Using 6 BIT PANEL
 - => Back-Light Control of Inverter voltage polarity
(Bright Max : HIGH , Min : LOW)

3. OPTION : - X3 - BYPASS
 - => Using 8 BIT PANEL
 - => Back-Light Control of Inverter voltage polarity
(Bright Max : LOW , Min : HIGH)

4. OPTION : - X3 - INVERT
 - => Using 8 BIT PANEL
 - => Back-Light Control of Inverter voltage polarity
(Bright Max : HIGH , Min : LOW)

Select no 4 in the case that no 4 is not selected .

2-4. Adjustment Instruction of VPC3230

1. Adjustment item : Function of adjusting DEFAULT VALUE of VPC3230 DEVICE.
2. Adjustment process : After assembling the SET, do the adjustment .
3. Preliminary adjustment
 - : 1) Connect Outlet of VIDEO PATTERN GENERATOR to the input terminal of CVBS.
 - 2) TEST PATTERN : Select COLOR BAR PATTERN
 - 3) Turn on the SET, and then select in VIDEO MODE.
4. Adjustment Instruction
 - : 1) Press SEL & Power Key in Front Panel at the same time , and go to Factory mode.
 - 2) Select VPC3230 in Factory mode.
 - 3) Adjust to the following levels with VOLUME UP/DOWN, CH UP/DOWN
 - CONTRAST 52
 - BRIGHT 9
 - PEAKING 0
 - CIP CONTRAST 7
 - CIP BRIGHT 7

No need to adjust when the SET is stable.

3. Inspection Specification

3-1. Input Specification of LCD PANEL (Total Inspection)

	Inspection Procedure	Standard	Remark
1	Turn off the power of JIG (check the power of JIG)		
2	Connect BACK LIGHT CONNECTOR of LCD PANEL to JIG		
3	Connect PANEL Connector of JIG to LCD PANEL		
4	Turn on the power of JIG POWER ON		
5	After receiving Black Pattern, check the number of radiant Pixel	No the matter	
6	After receiving White Pattern, check the number of radiantless Pixel	2 Pixel and less	
7	After receiving White Pattern, check the spots	No the matter	
8	Turn off the power of JIG		
9	Disconnect PANEL Connector		
10	Disconnect Back Light Connector		
RMK	1) In order to prevent the spots of PANEL, inspect with Gloves on 2) In the time of connecting & disconnecting the Connector, surely turn off the power of JIG, and then go on the inspection. 3) Test Pattern : Full White & Full Black Pattern		

3-2. Inspection Specification of INVERTOR (Total inspection)

	Insepction procedure	Standard	
1	Turn off the power of JIG (check the power of JIG)		
2	Connect 2P CONNECTOR in the upper part of JIG to CN3		Back-Light Con'
3	Connect 2P CONNECTOR in the lower part of JIG to CN2		Back-Light Con'
4	Connect 5P CONNECTOR of JIG to CN1		Inverter Con'
5	Turn on the power of JIG POWER ON		
6	Check the screen is displaying normally		
7	Change "Brightness" and check the variation of brightness level		
8	Turn off the power of JIG		
9	Disconnect the Connector		
RMK	1) TEST PATTERN : White / Black Pattern 2) In the time of connection & disconnection the CONNECTOR, surely turn off the power of JIG , and then go on inspection => warning : pay attention to high voltage		

3-3. Inspection specification of ASSY-CONTROL

	Inspection procedure	standard	Remark
1	Turn off the power of JIG (check the power of JIG)		
2	Connect 7P Connector with JIG		
3	Check the tight insertion of TACT SW	Tight insertion	
4	Turn on the power of JIG.		
5	Check the color of LED is red	STAND BY : RED LED	
6	Press POWER KEY , and then check the screen is displaying & LED is lighting in green .	POWER ON : GREEN LED	
7	Press each KEY and check the function	CHECK key SW	
8	With REMOTECON , turn off the power	Check REF LED	
9	Turn off the power of the JIG		
10	Disconnect the Connector		
RMK	1) After checking the connecting status of 15PIN in JIG , go on the inspection : in case of no sign , KEY may not work .		

Operating procedure	OSD specification
<p>1. POWER KEY setting</p> <p>2. MENU KEY setting</p> <p>3. SELECT KEY setting</p> <p>4. KEY setting</p> <p>5. KEY setting</p> <p>6. KEY setting</p> <p>7. KEY setting</p>	<p>=> POWER ON</p> <div style="display: flex; justify-content: space-around; align-items: center;"> <div style="border: 1px solid black; background-color: cyan; padding: 5px; width: 30%;"> <p style="background-color: blue; color: white; text-align: center; margin: 0;">PICTURE</p> <p>CONTRAST BRIGHTNESS SHARPNESS COLOR</p> </div> <div style="font-size: 2em;">→</div> <div style="border: 1px solid black; background-color: cyan; padding: 5px; width: 30%;"> <p style="background-color: blue; color: white; text-align: center; margin: 0;">PICTURE</p> <p>CONTRAST BRIGHTNESS SHARPNESS COLOR</p> </div> <div style="font-size: 2em;">→</div> <div style="border: 1px solid black; background-color: cyan; padding: 5px; width: 30%;"> <p style="background-color: blue; color: white; text-align: center; margin: 0;">SOUND</p> <p>TREBLE BASS BALANCE S. MODE</p> </div> </div> <div style="text-align: center; margin: 10px 0;">↓</div> <div style="display: flex; justify-content: space-around; align-items: center;"> <div style="border: 1px solid black; background-color: cyan; padding: 5px; width: 30%;"> <p style="background-color: blue; color: white; text-align: center; margin: 0;">FUNCTION</p> <p>TRACKING INFORMATION TUNING LANGUAGE</p> </div> <div style="font-size: 2em;">←</div> <div style="border: 1px solid black; background-color: cyan; padding: 5px; width: 30%;"> <p style="background-color: blue; color: white; text-align: center; margin: 0;">SOUND</p> <p>TREBLE BASS BALANCE S. MODE</p> </div> <div style="font-size: 2em;">←</div> <div style="border: 1px solid black; background-color: cyan; padding: 5px; width: 30%;"> <p style="background-color: blue; color: white; text-align: center; margin: 0;">SOUND</p> <p>TREBLE BASS BALANCE S. MODE</p> </div> </div> <div style="text-align: center; margin: 10px 0;">↓</div> <div style="display: flex; justify-content: space-around; align-items: center;"> <div style="border: 1px solid black; background-color: cyan; padding: 5px; width: 30%;"> <p style="background-color: blue; color: white; text-align: center; margin: 0;">FUNCTION</p> <p>TRACKING INFORMATION TUNING LANGUAGE</p> </div> <div style="font-size: 2em;">→</div> <div style="border: 1px solid black; background-color: cyan; padding: 5px; width: 30%;"> <p style="background-color: blue; color: white; text-align: center; margin: 0;">TUNING</p> <p>SORT AUTO TUNING MANUAL TUNING FINE TUNING CH SKIP</p> </div> <div style="font-size: 2em;">→</div> <div style="border: 1px solid black; background-color: cyan; padding: 5px; width: 30%;"> <p style="background-color: blue; color: white; text-align: center; margin: 0;">FUNCTION</p> <p>TRACKING INFORMATION TUNING LANGUAGE</p> </div> </div>

3-4. INSPECTION SPECIFICATION OF ASSY-MAIN

3-4-1 INSPECTION IN TV MODE

1. Required tool : PM5518 (RF PATTERN GENERATOR – built in SAP function) , simple JIG
2. Preliminary inspection : 1) set up PM5518 : RF FREQ' : 55.25MHZ ,
PATTERN : COLOR BAR ,SOUND : STEREO (3KHZ/1KHZ),
SYSTEM : PAL/NTSC - 6 (REAR PANEL) RF GAIN :60dBuV
3. Inspection procedure :
 - 1) Inserting Connector
 - 2) Power on the JIG , POWER ON the Set.
 - 3) TUNING (in case of NTSC, select channel 2, in case of PAL/SECAM , AUTO TUNING : select the stored channel .
 - 4) Check COLOR & the sound of SPEAKER (L : 3KHZ , R : 1KHZ)
 - 5) Changing VOLUME , check up & down of sound (VOLUME 0 : MUTE , others : LEVEL up & down)
 - 6) With MUTE KEY of REMOCON , Check MUTE function
 - 7) With MTS KEY of REMOCON, after converting to MONO, check SOUND
 - 8) When converting " CONTRAST" in PICTURE MENU , check the conversion of light & darkness in screen
 - 9) When converting " BRIGHTNESS" of PICTURE MENU , check the conversion of brightness in screen
 - 10) When converting " COLOR" of PICTURE MENU, check COLOR GAINING (0 : NO COLOR)
 - 11) In the time of change " TINT" in PICTURE MENU , check COLOR VARIATION.
 - 12) With P.STD KEY of REMOCON , check the conversion of the Screen
 - 13) With S.STD KEY of REMOCON , check the conversion of the Sound
 - 14) With SURROUND KEY of REMOCON, check the conversion of the Sound
 - 15) Convert to STAND BY MODE.
 - 16) Power off the JIG , and then disconnect JACK & CONNECTOR.

3-4-2. Inspection item in VIDEO MODE

1. Required tool; : PM5518 (PATTERN GENERATOR) , VTR (NTSC) , SCOPE , JIG1 ,
2. Preliminary item : 1) set up PM5518 : RF FREQ' :55.25MHZ , PATTERN : COLOR BAR ,
SOUND : STEREO (3KHZ/1KHZ)
SYSTEM : PAL/NTSC - 6 (REAR PANEL) RF GAIN : 60dBuV
3. Insepction procedure :
 - 1) Inserting Connector
 - 2) Power on JIG , and then POWER ON the set. (Check the color of LED : GREEN)
 - 3) Inserting RCA-JACK BLOCK S-VHS JACK & PC AUDIO JACK.
 - 4) After converting to VIDEO MODE , check the screen & Sound .
 - 5) In the screen of SCOPE check that the output is L : 3KHZ , R : 1KHZ
 - 6) With S.MODE KEY of Remote control , after converting to MONO , check the SOUND (L /R :3KHZ)
 - 7) After converting to S-VIDEO MODE , check the screen & SOUND
 - 8) After converting PC MODE, check the output of PC AUDIO
 - 9) After inserting SCART CABLE
 - 10) After converting to STAND BY MODE, check the color of LED (LED color : RED)
 - 11) Power off JIG , and then disconnect JACK & CONNECTOR

3-4-3. Inspection in PC MODE

1. Inspection item : in each MODE setting PC , inspect the status
 2. Preliminary item : 1) MSPG-925L Setting
- Pattern : Select 1DOT W/BLACK (PATTERN NO : 28 , MODEL NO.: 21)
 3. Inspection procedure:
 - 1) After inserting 15pin JACK and DC-JACK, POWER ON
 - 2) Select PC MODE.
 - 3) After converting MODEL NO of MSPG-925L to 21 (1024 x 768 @85Hz) , check the screen status
 - 4) After converting MODEL NO of MSPG-925L to 15 (800 x 600 @ 85Hz) , check the screen status
 - 5) After converting MODEL NO of MSPG-925L to 10 (720 x 400 @ 70.1Hz) , check the screen status.
 - 6) After converting MODEL NO of MSPG-925L to (640 x 480 @ 85Hz) , check the screen status
 - 7) After converting MODEL NO of MSPG-925L to 1 (640 x 350 @ 70.1Hz) , check the screen status
 - 8) With AUTO POSITION , set up the screen position
 - 9) After converting MODEL NO of MSPG-925L to 28 (1024 x 768 @ 85Hz) ,
In OSD MENU / FUNCTION / TRACKING , with AUTO TRACKING , set up the screen position
 - 10) Disconnect DC-JACK , 15pin JACK
-

4. BLOCK DIAGRAM

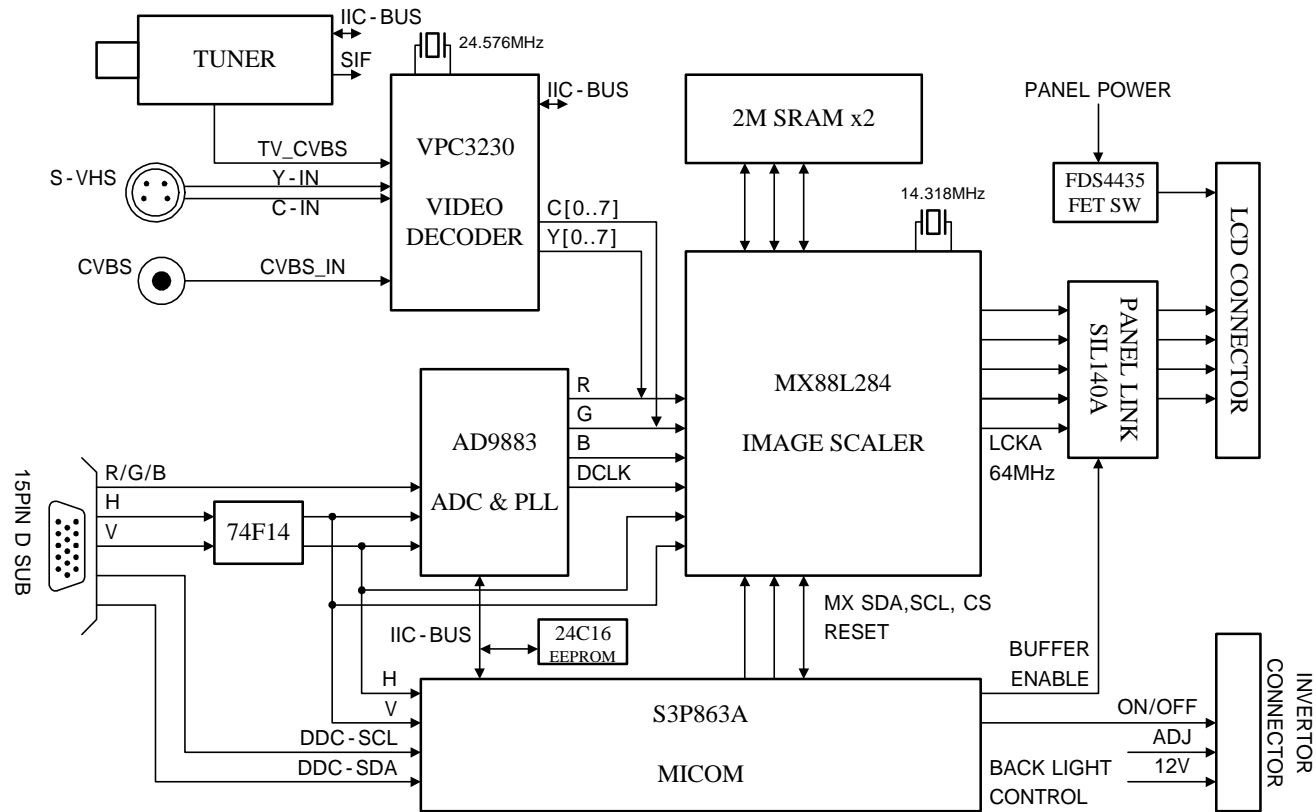

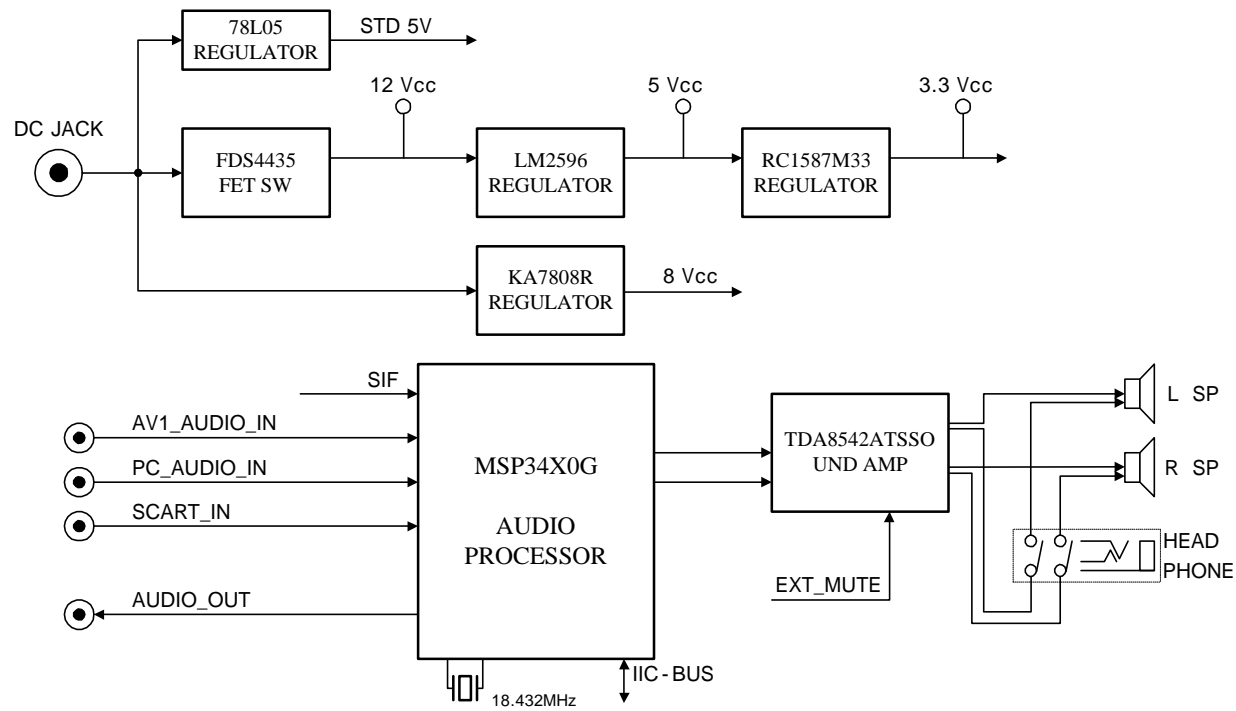

BLOCK DIAGRAM (LCD 15.1" TV)

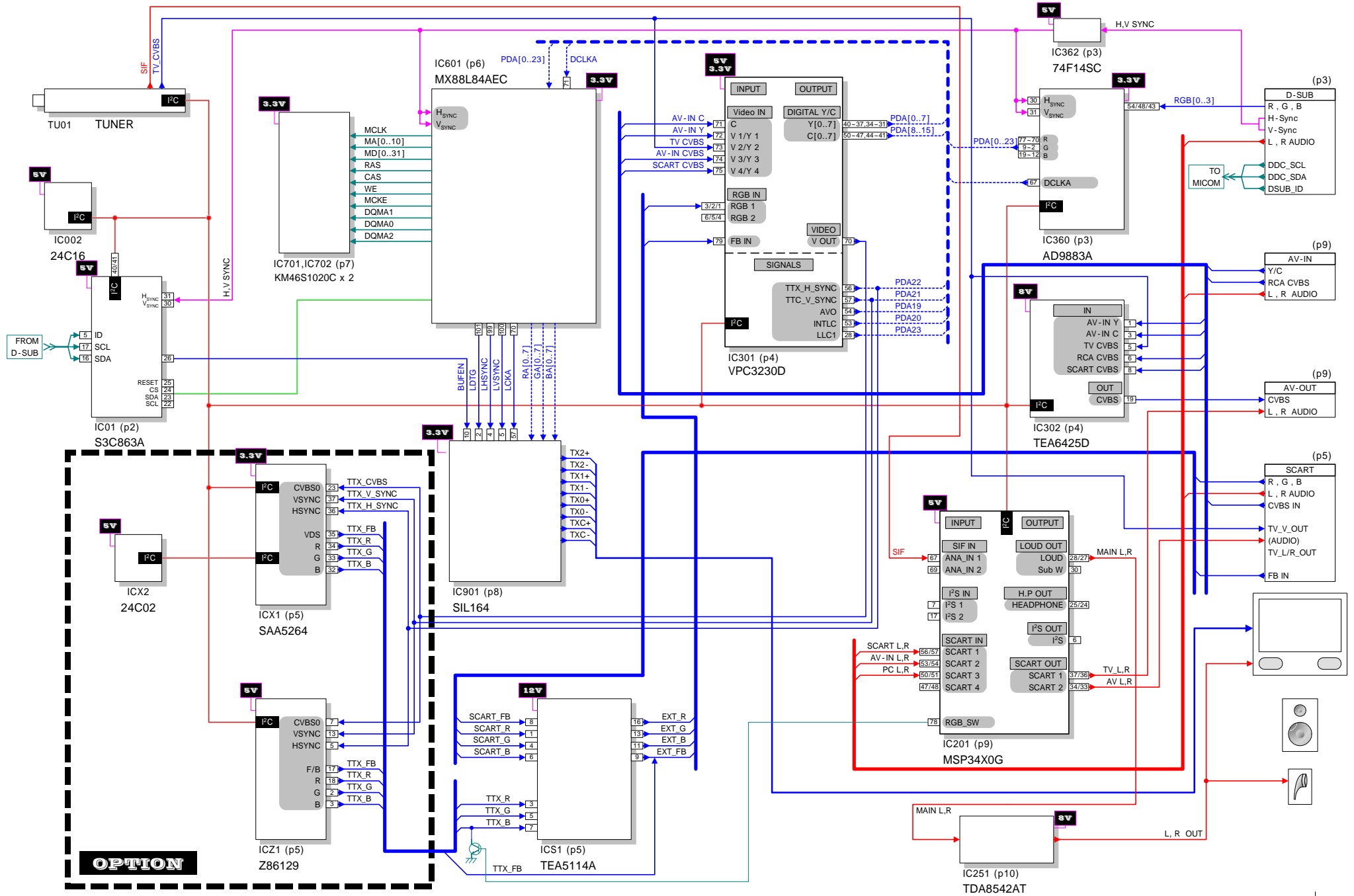

5. Circuit Diagram (15.1" LCD TV)

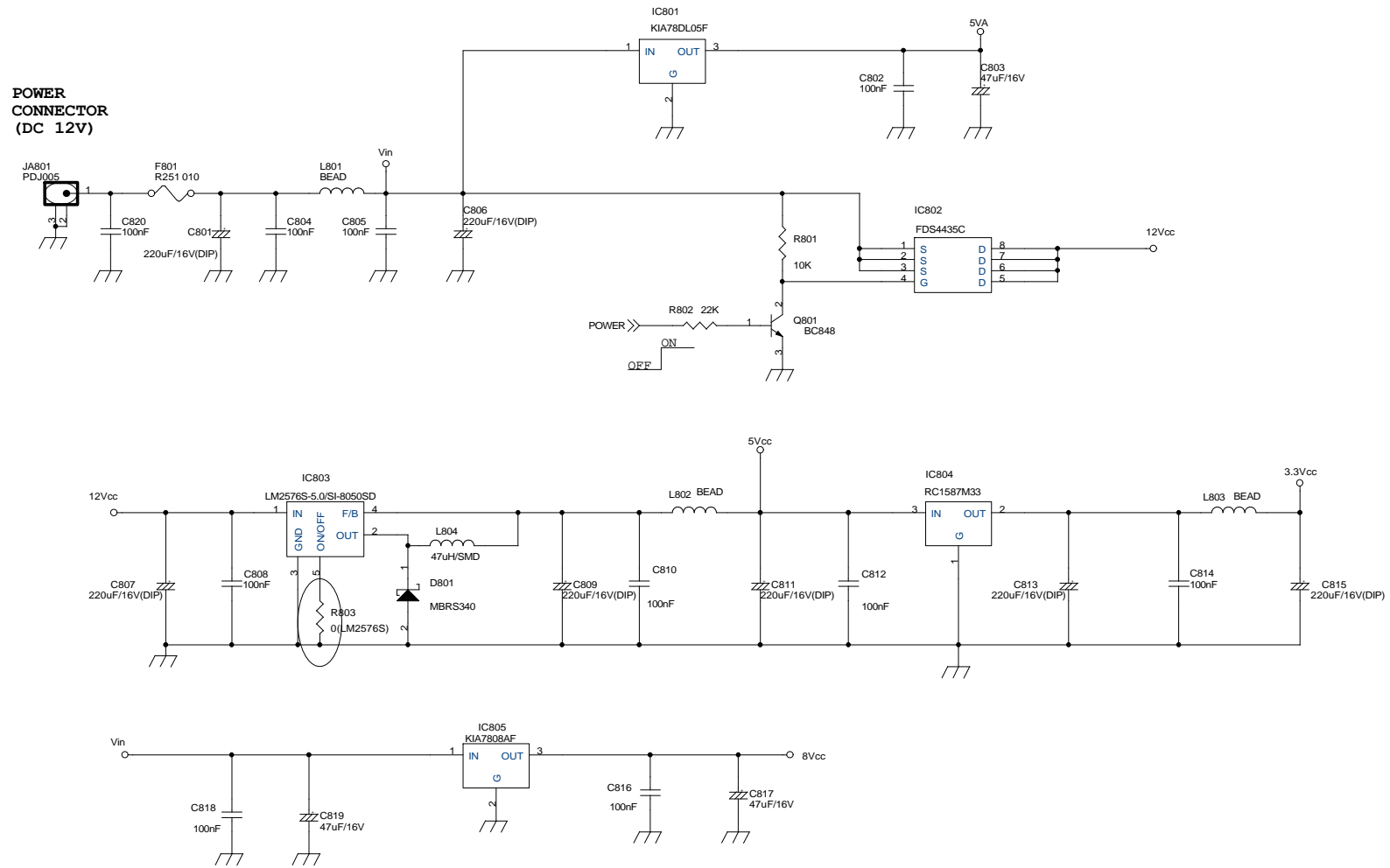

Title		15.1" LCD TV	
Size	A3	Document Number	Power Block
Date:	Wednesday, March 06, 2002	Sheet	1 of 11
			Rev V0.6

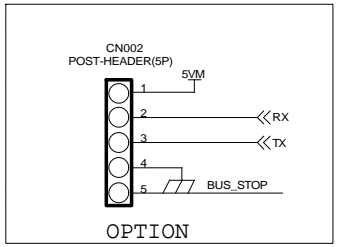
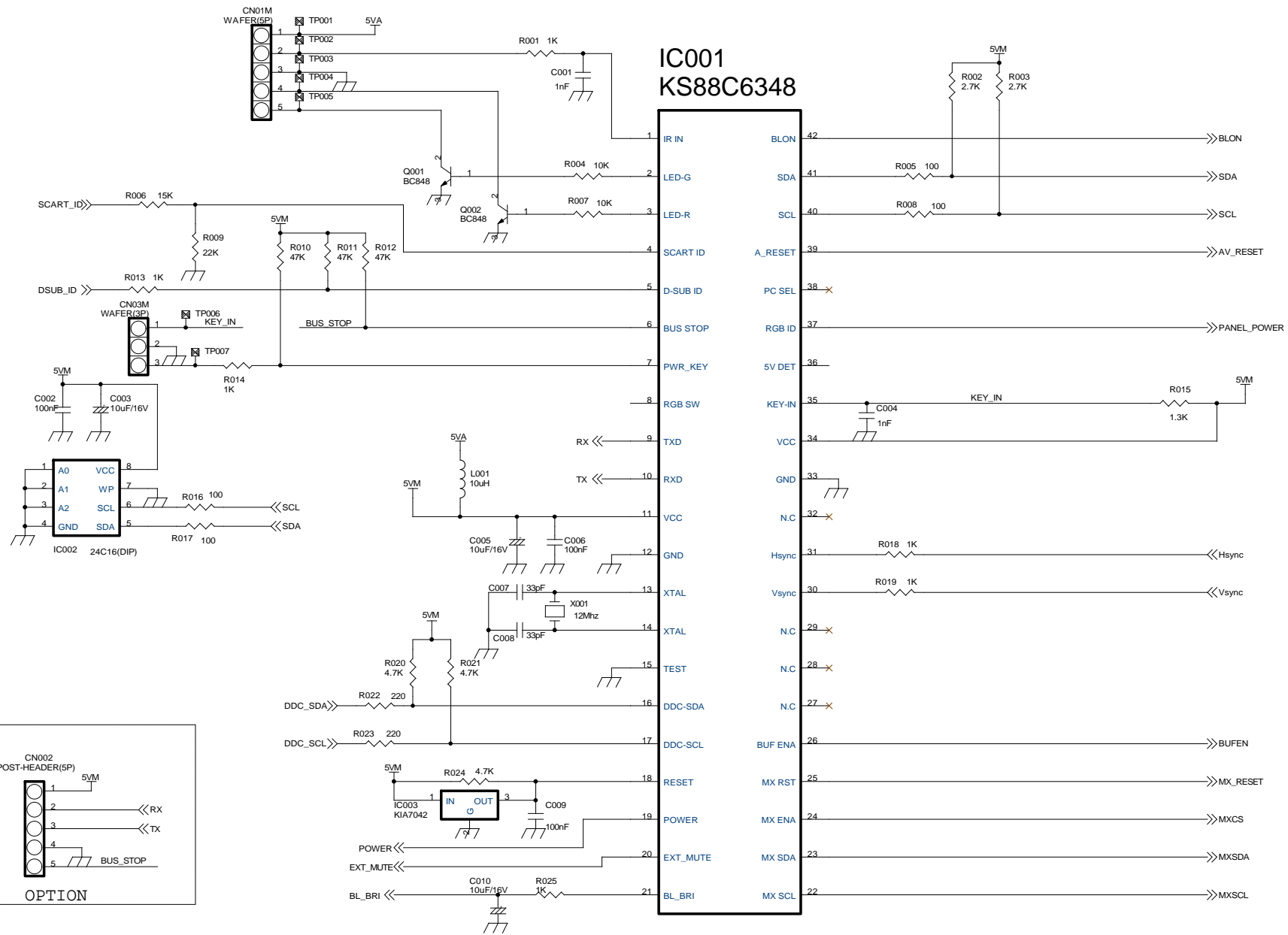

Title		15.1" LCD TV	
Size	A3	Document Number	Micom Block
Date:	Wednesday, March 06, 2002	Sheet	2 of 11
Rev	V0.6		

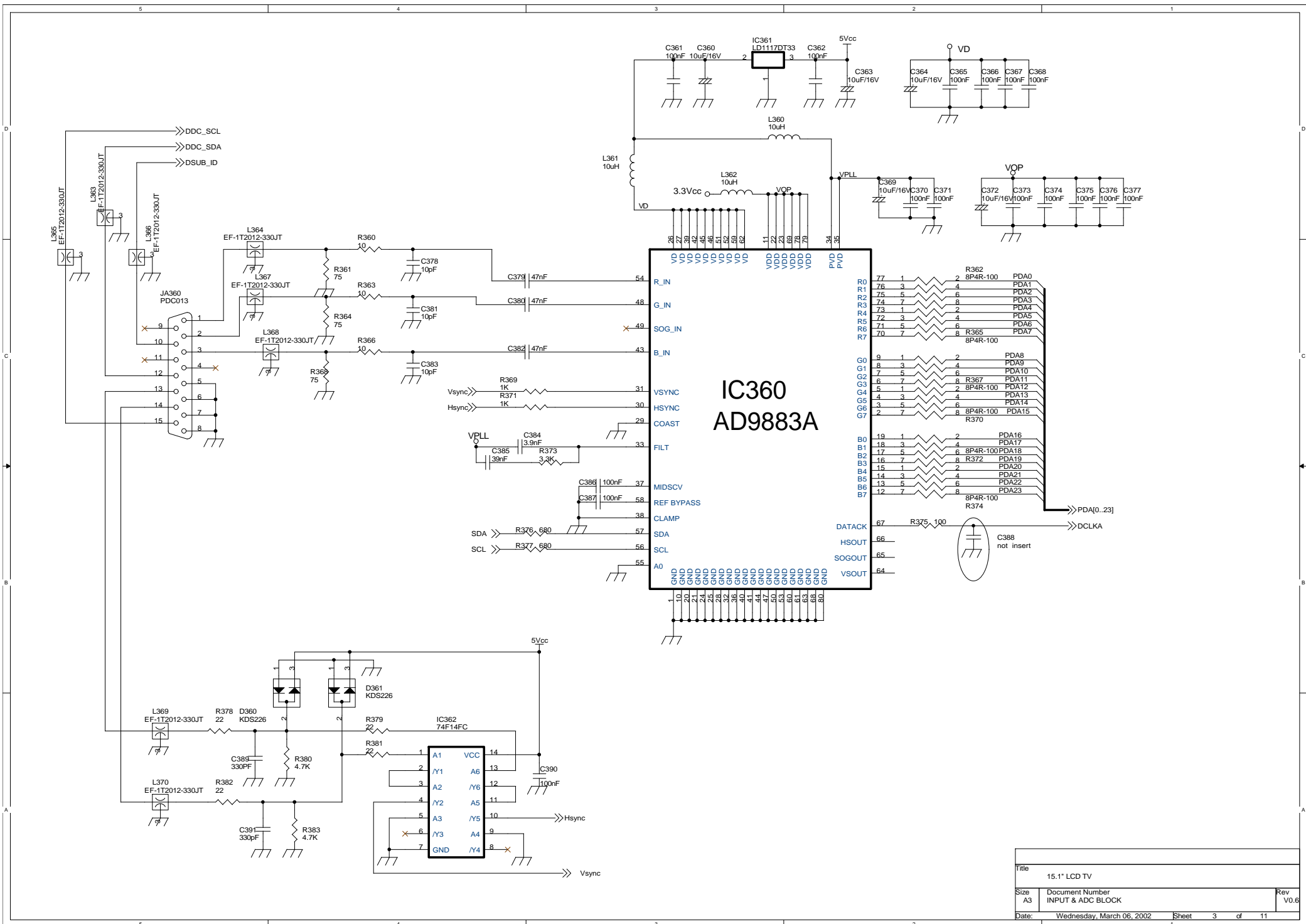

Title		
15.1" LCD TV		
Size	Document Number	Rev
A3	INPUT & ADC BLOCK	V0.6
Date:	Wednesday, March 06, 2002	Sheet 3 of 11

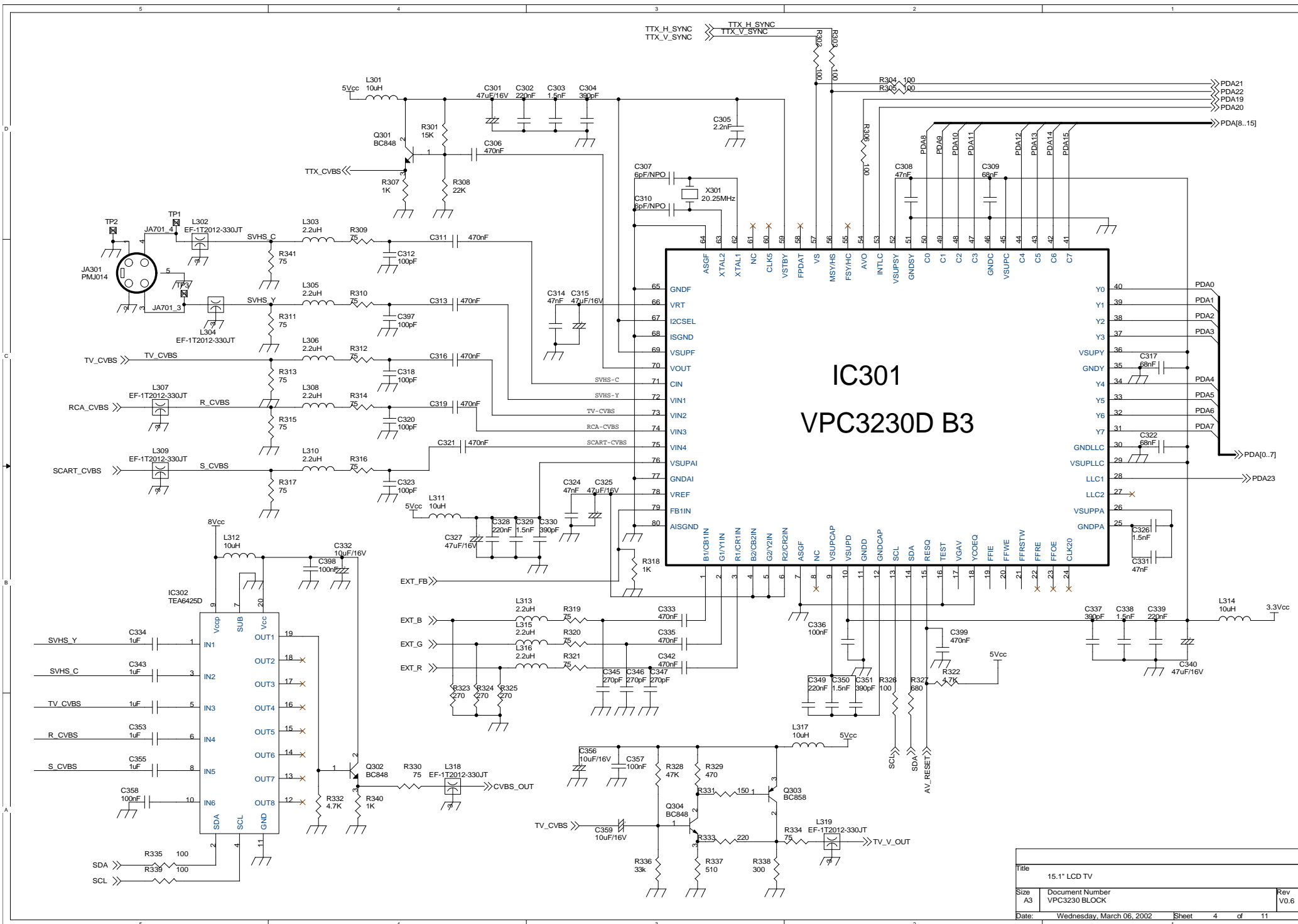

Title		
15.1" LCD TV		
Size	Document Number	Rev
A3	VPC3230 BLOCK	V0.6
Date:	Wednesday, March 06, 2002	Sheet 4 of 11

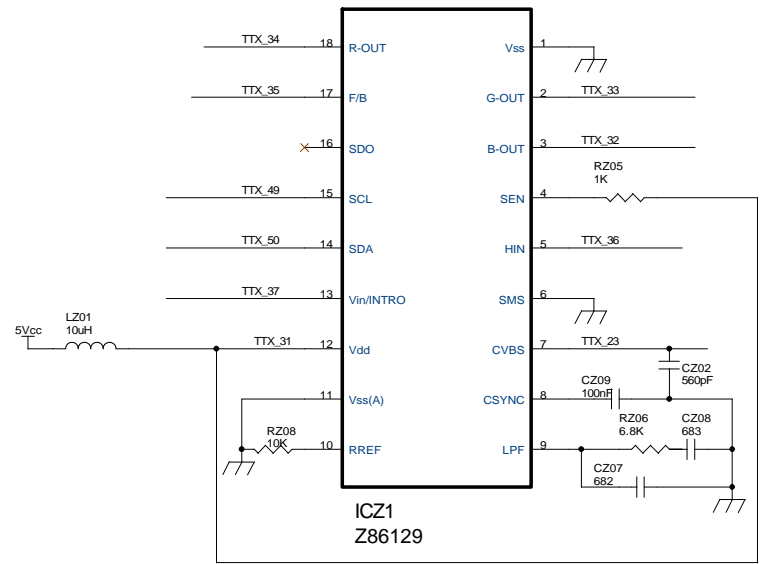
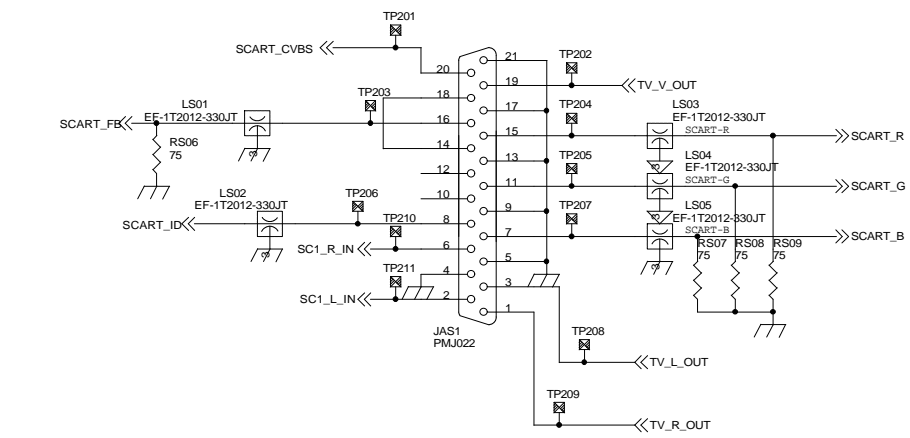
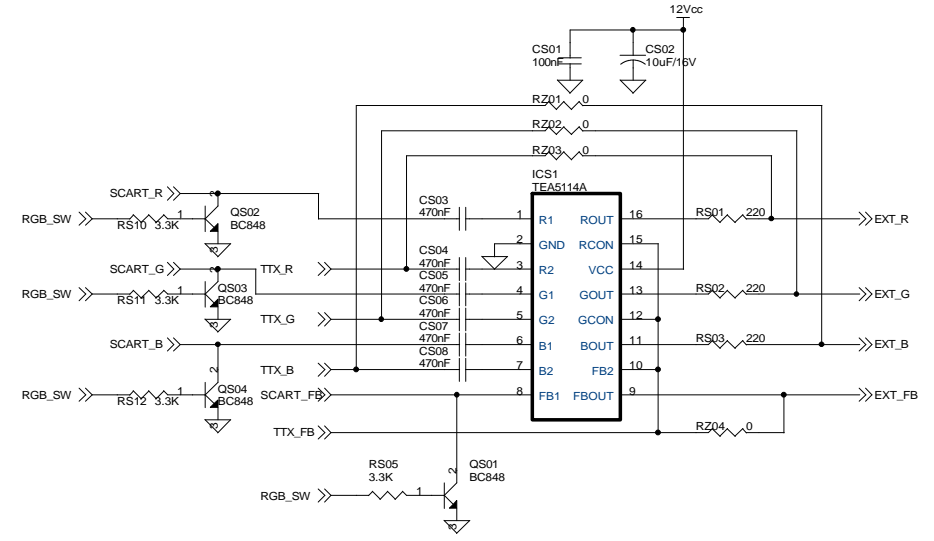
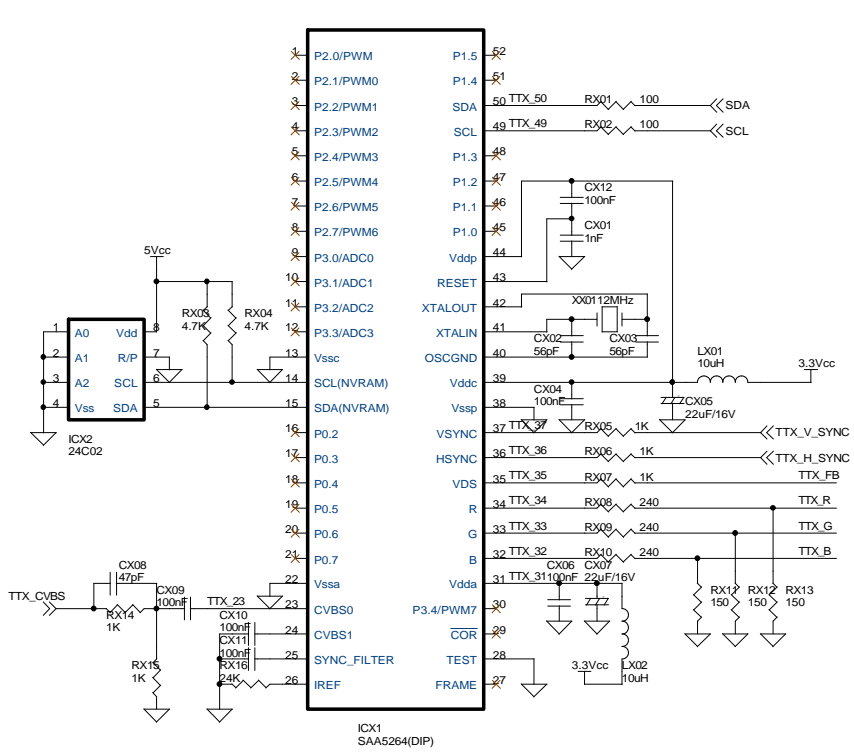

Title		
15.1" LCD TV		
Size	Document Number	Rev
A3	TTX BLOCK	V0.6
Date:	Wednesday, March 06, 2002	Sheet 5 of 11

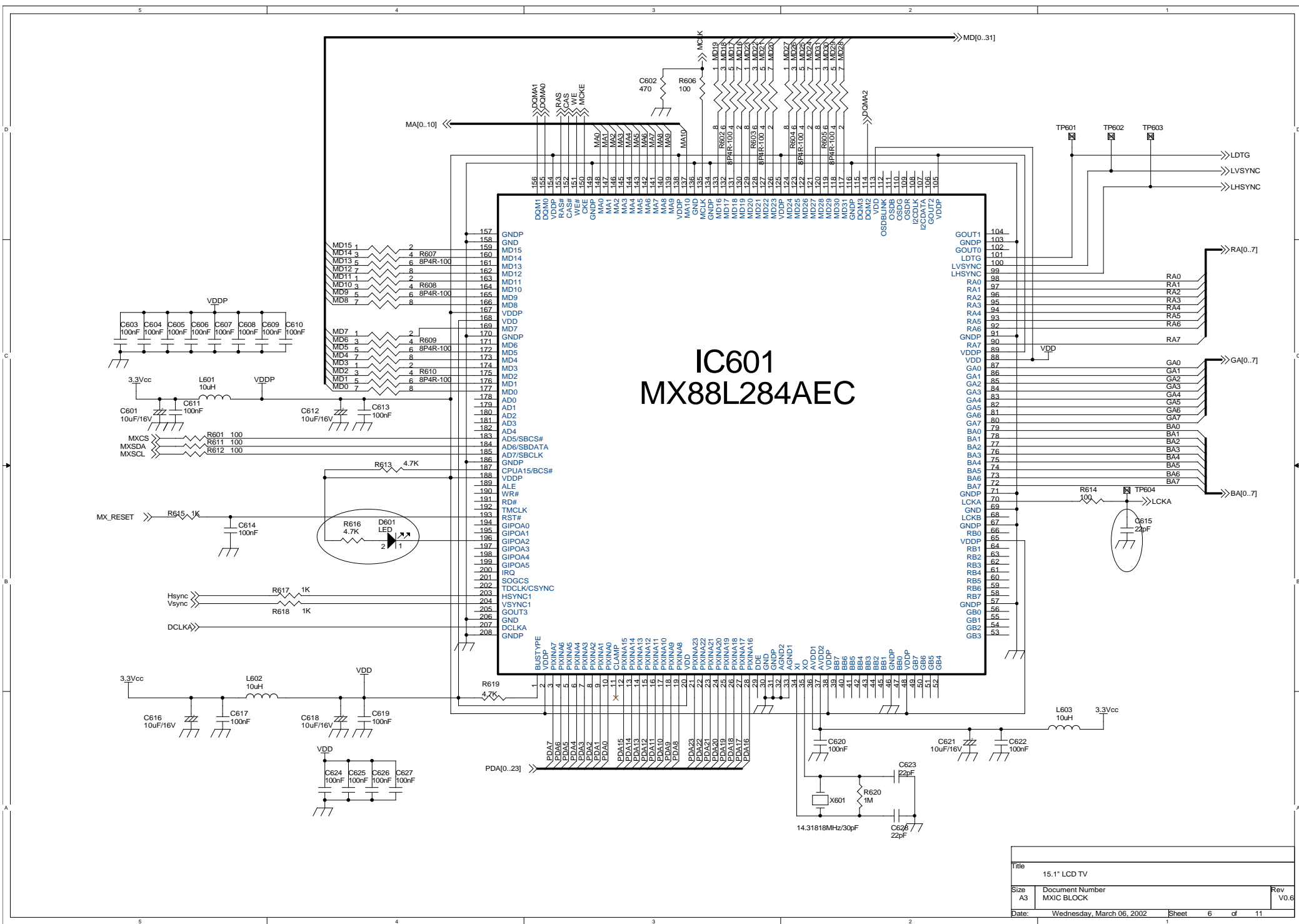

Title		
15.1" LCD TV		
Size	Document Number	Rev
A3	MXIC BLOCK	V0.6
Date:	Wednesday, March 06, 2002	Sheet 6 of 11

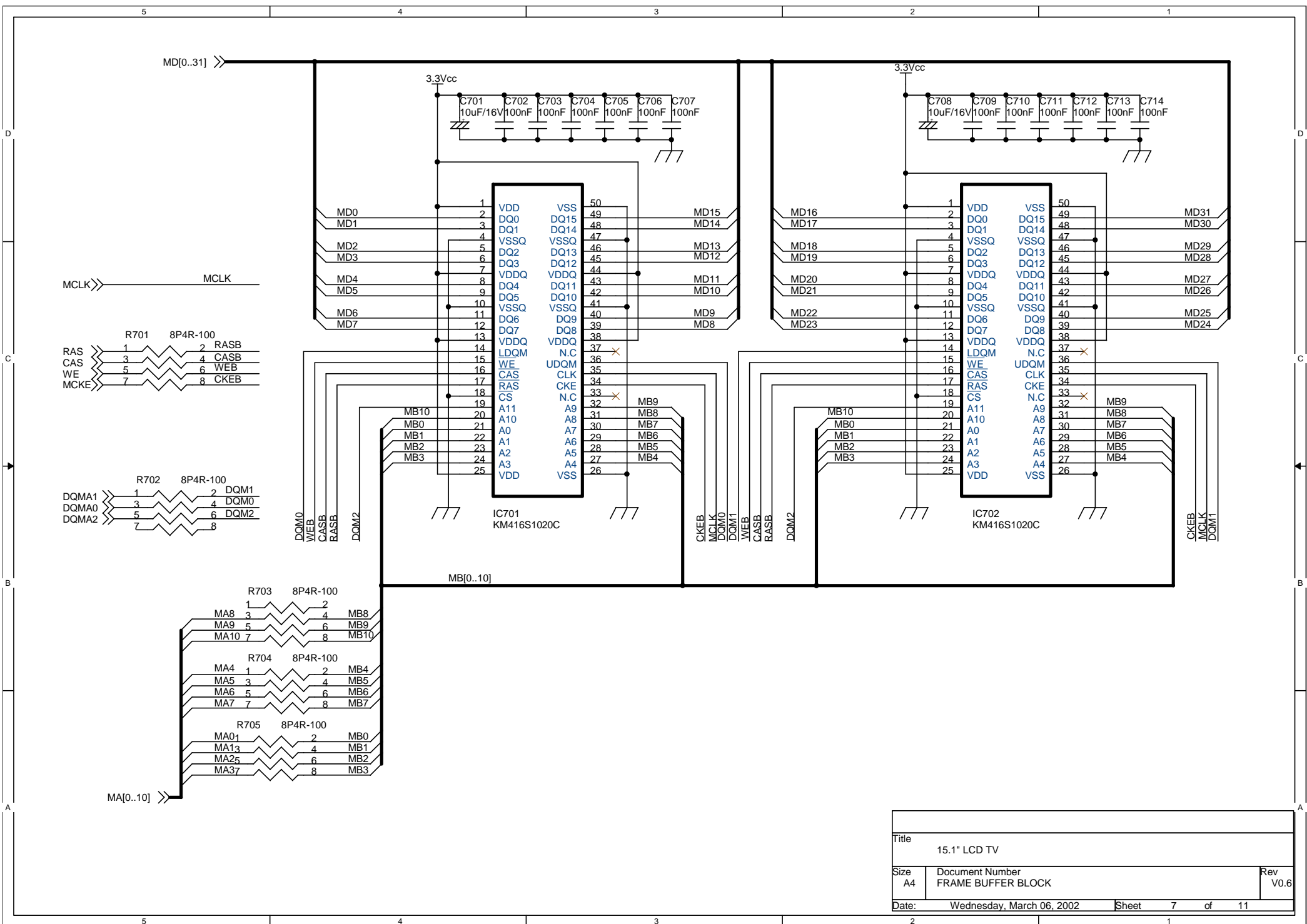

Title		
15.1" LCD TV		
Size	Document Number	Rev
A4	FRAME BUFFER BLOCK	V0.6
Date:	Wednesday, March 06, 2002	Sheet 7 of 11

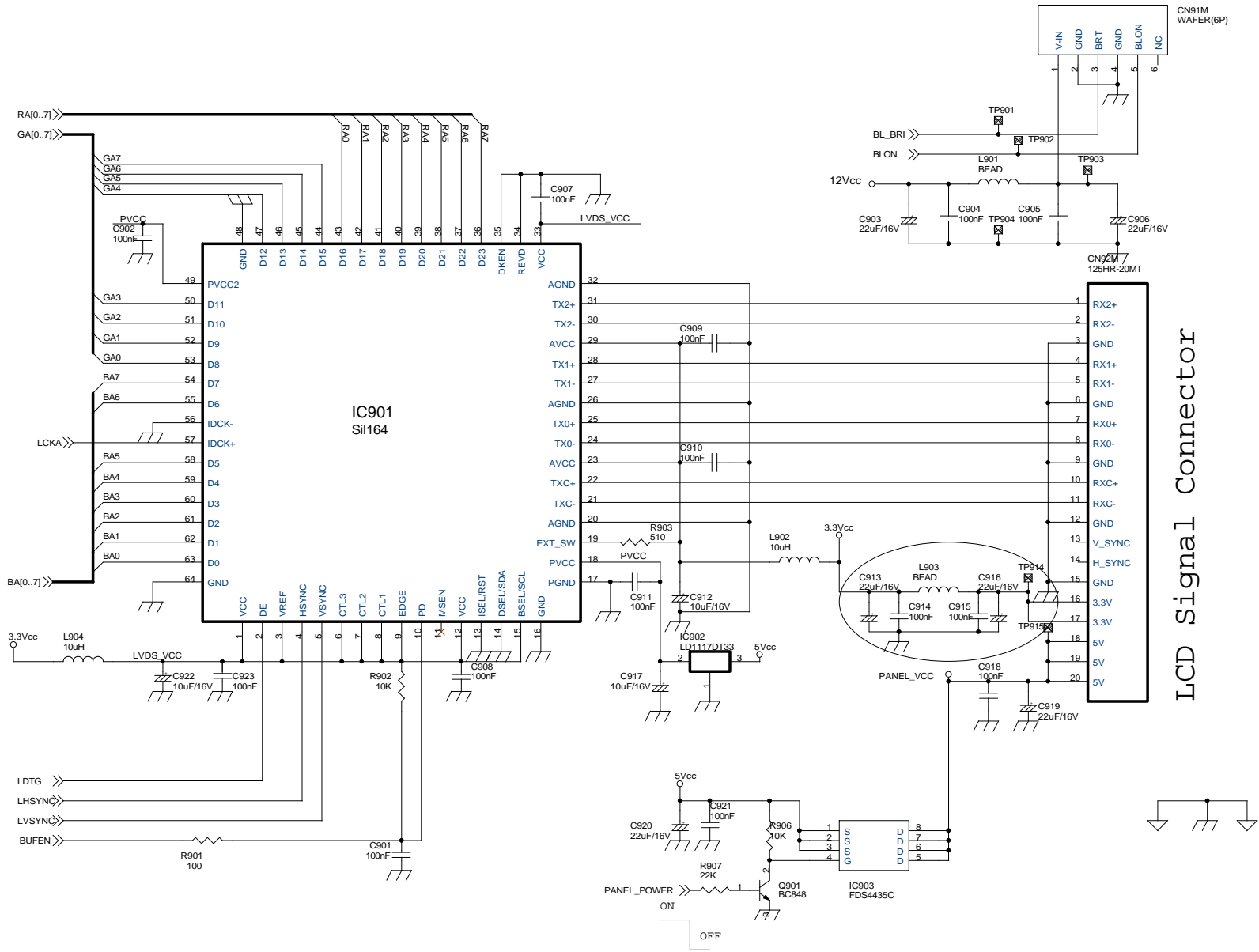

LCD Signal Connector

Title		
15.1" LCD TV		
Size	Document Number	Rev
A3	LVDS	V0.6
Date:	Wednesday, March 06, 2002	Sheet 8 of 11

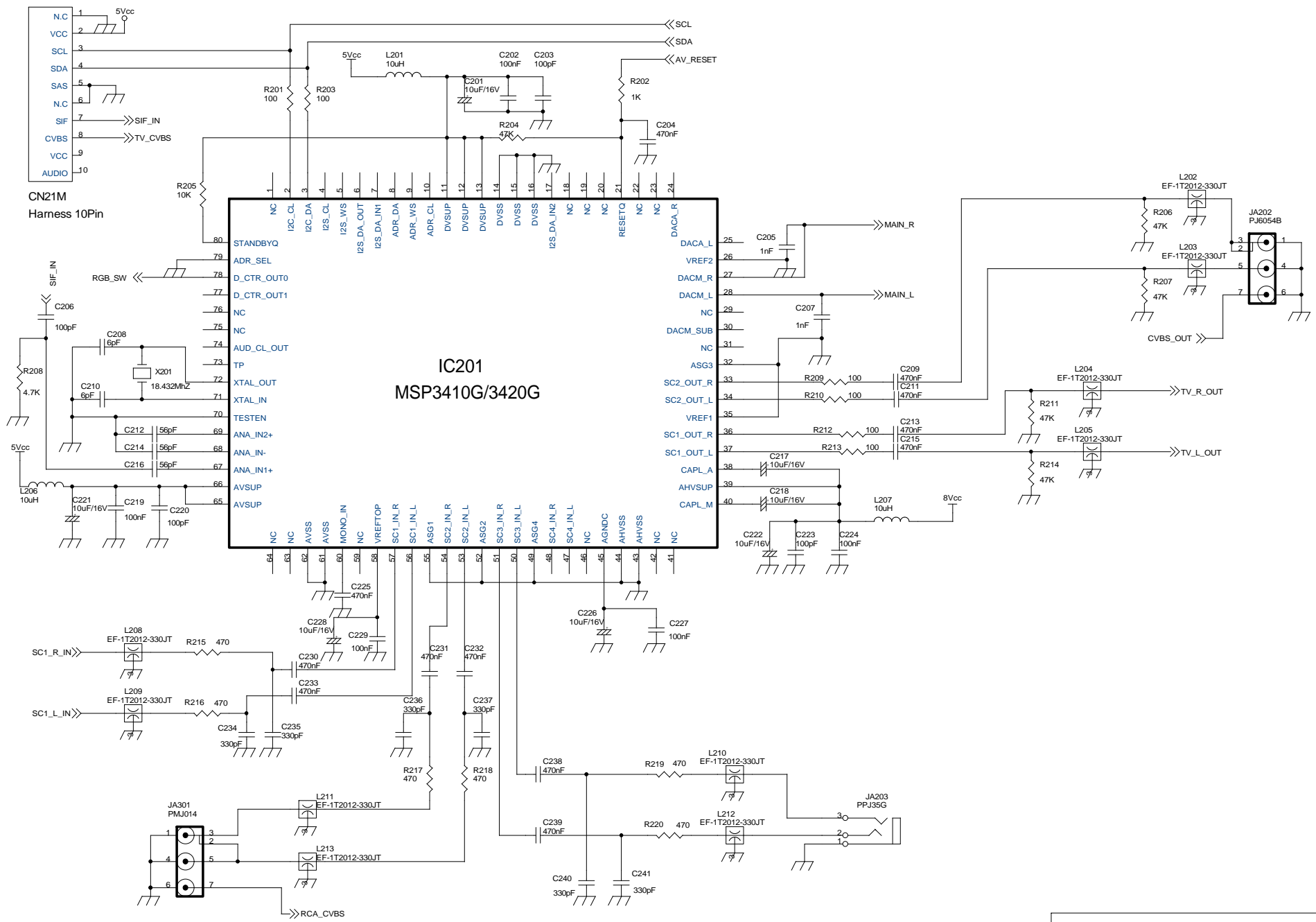

Title		
15.1" LCD TV		
Size	Document Number	Rev
A3	SOUND BLOCK	V0.6
Date:	Wednesday, March 06, 2002	Sheet 9 of 11

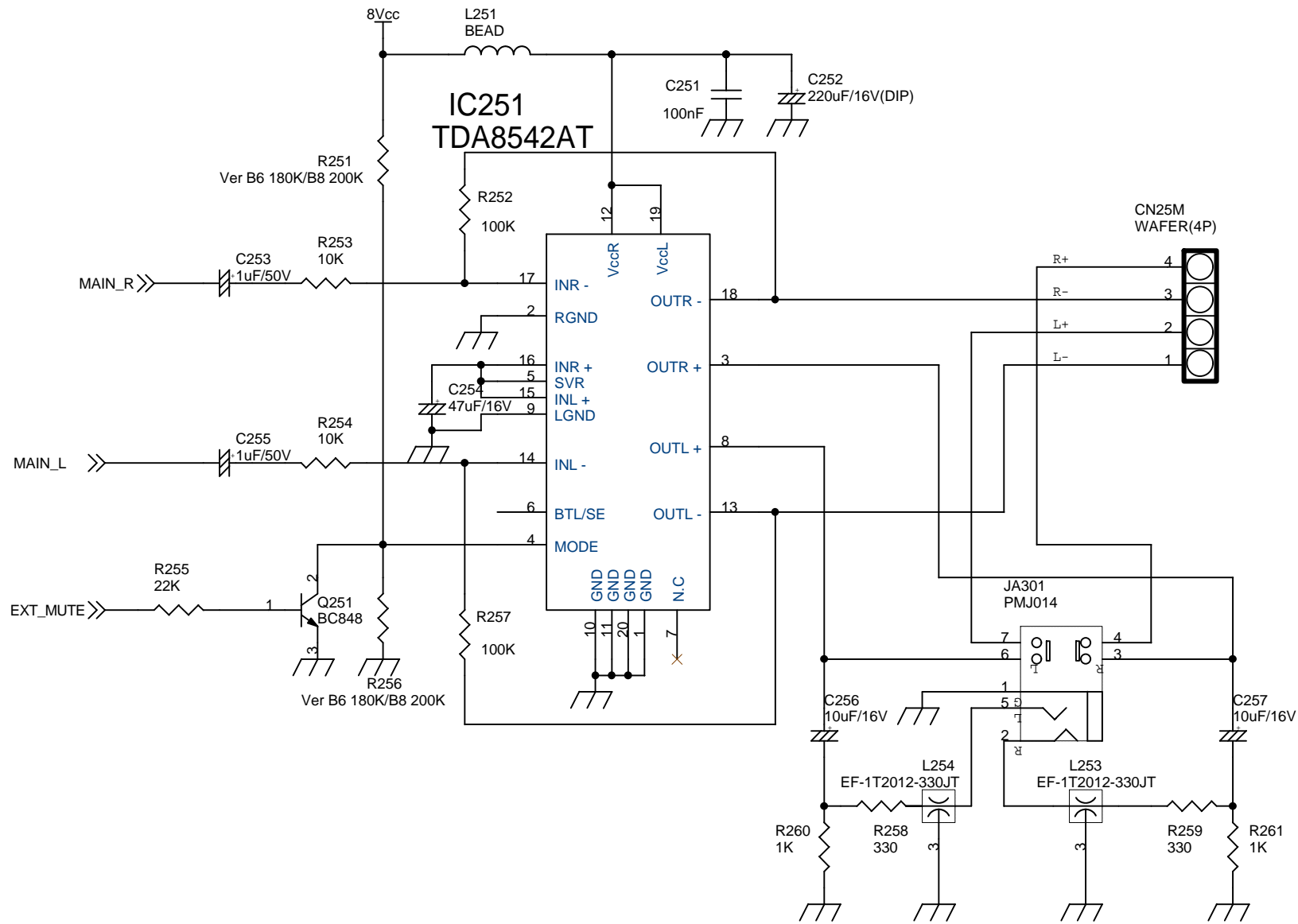

Title		
15.1" LCD TV		
Size	Document Number	Rev
A	SOUND AMP	V0.6
Date:	Wednesday, March 06, 2002	Sheet 10 of 11

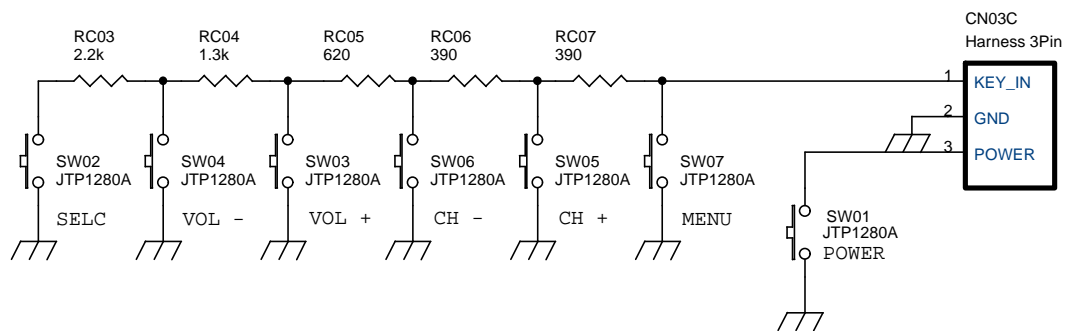
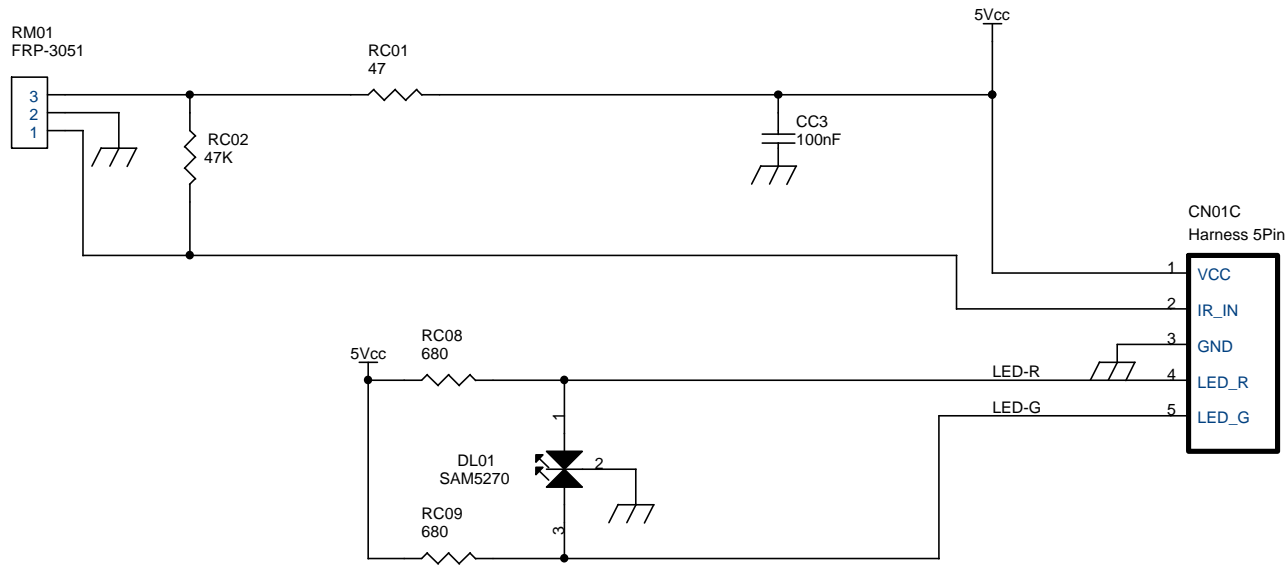

Title		
15.1" LCD TV		
Size	Document Number	Rev
A4	CONTROL	V0.6
Date:	Tuesday, November 13, 2001	Sheet 11 of 11
	2	1

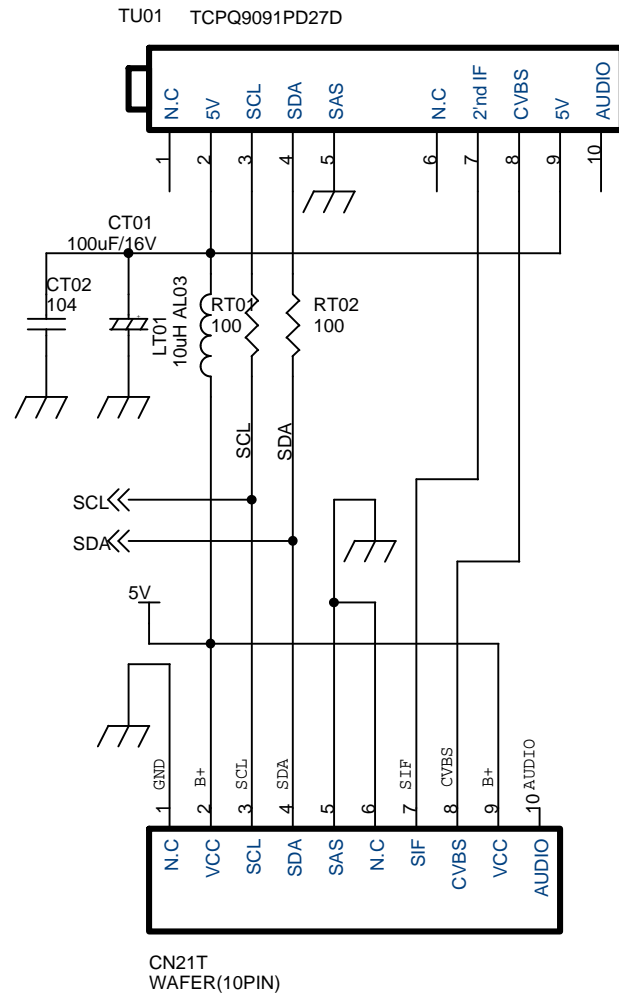

Title		
15.1" LCD TV		
Size	Document Number	Rev
A	TUNER	V0.6
Date:	Tuesday, November 13, 2001	Sheet 12 of 12

5. Circuit Diagram (20.1" LCD TV)

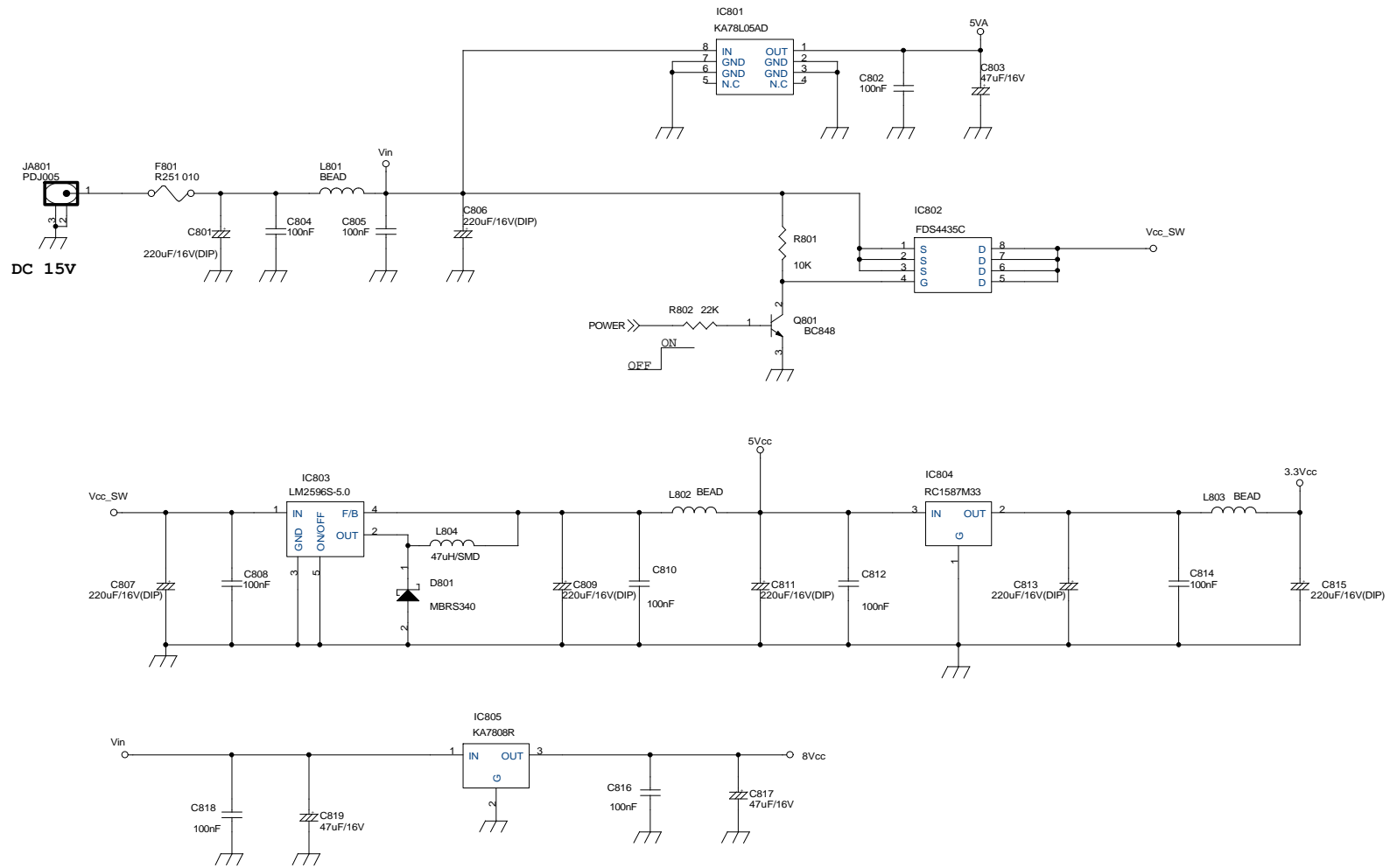

Title		
20.1" LCD TV		
Size	Document Number	Rev
A3	Power Block	V0.1
Date:	Monday, October 08, 2001	Sheet 1 of 11

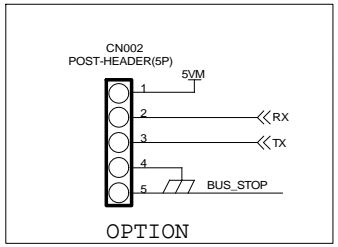
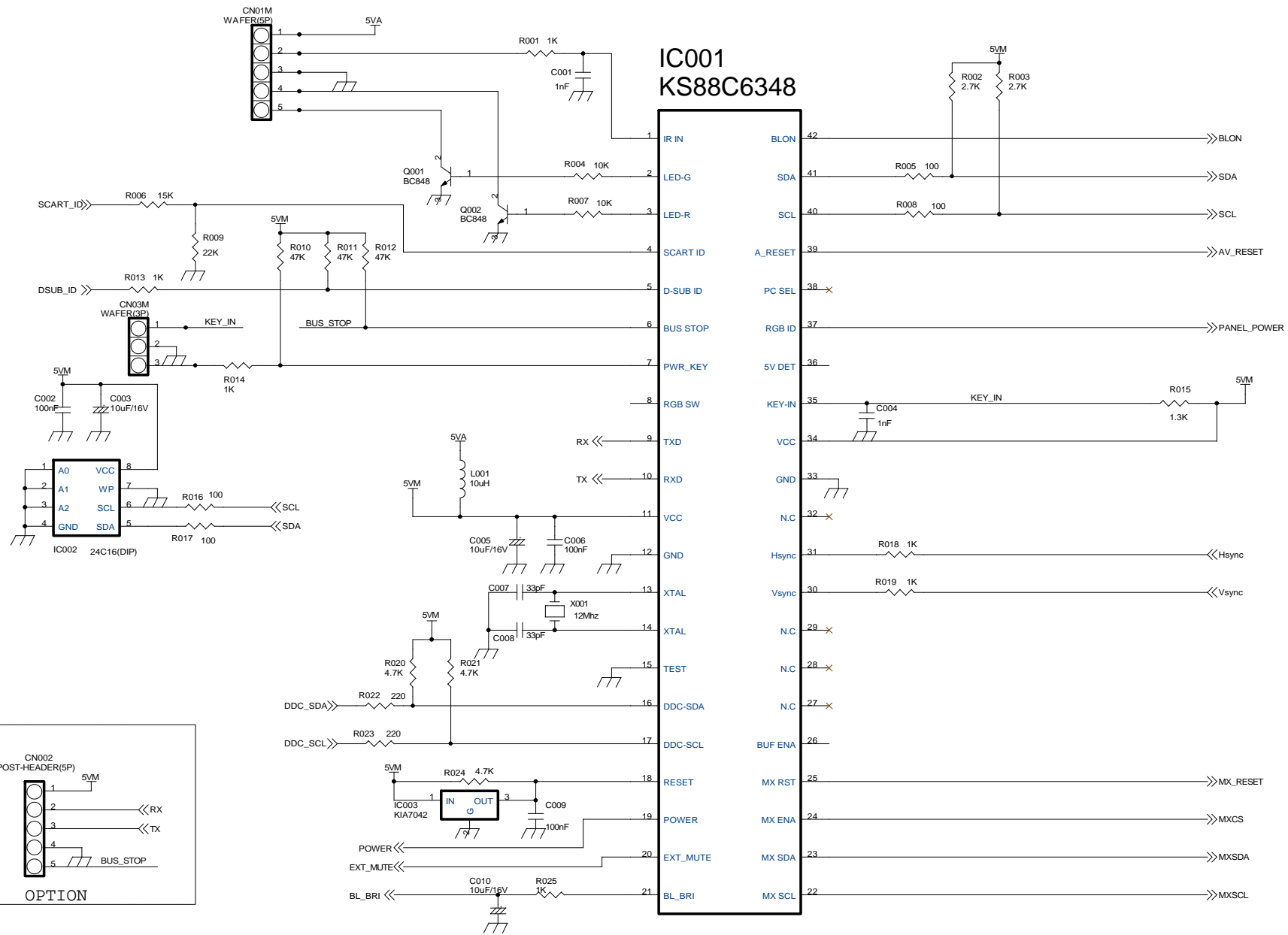

Title		
20.1" LCD TV		
Size	Document Number	Rev
A3	Micom Block	V0.1
Date:	Monday, October 08, 2001	Sheet 2 of 11

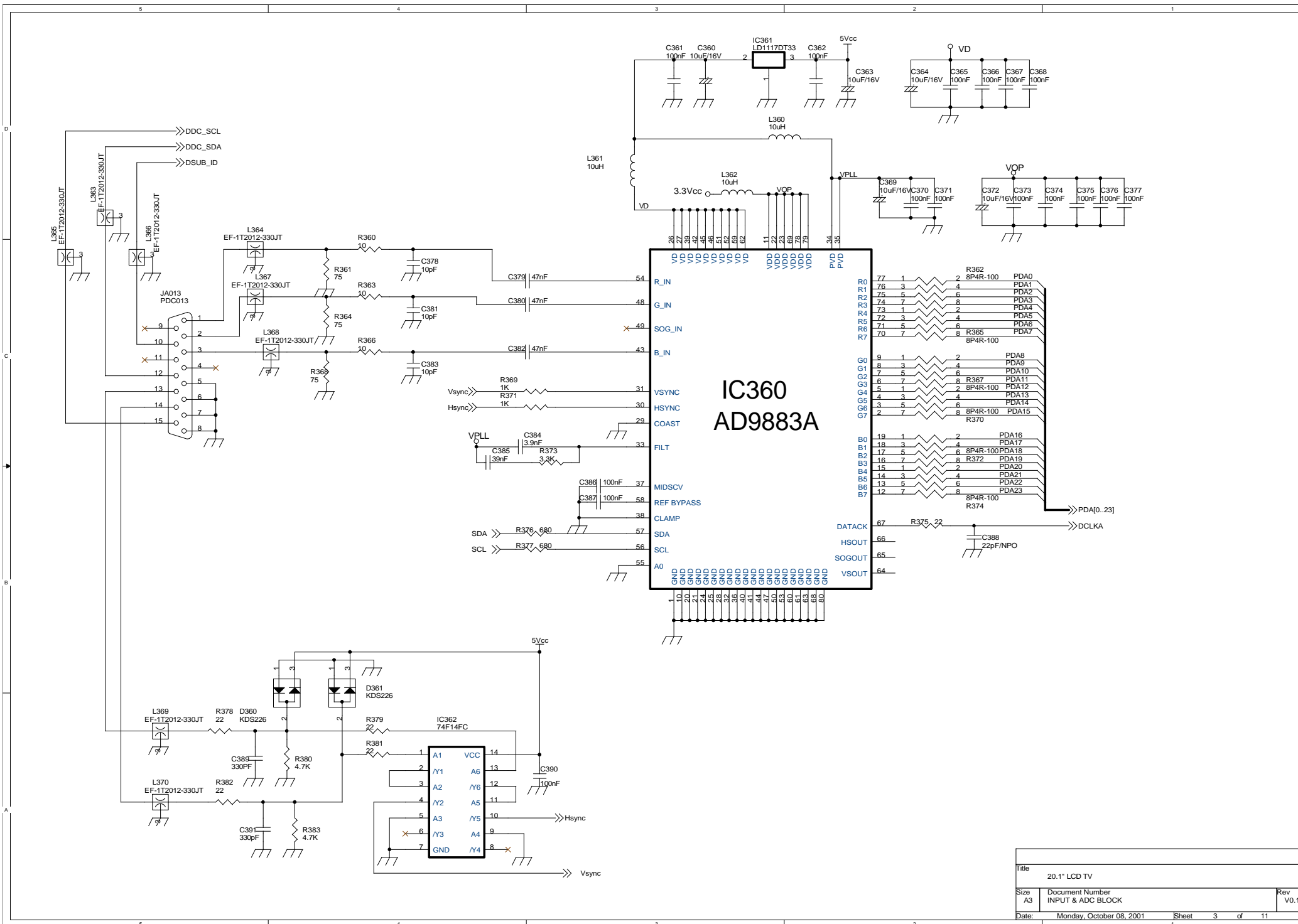

Title		
20.1" LCD TV		
Size	Document Number	Rev
A3	INPUT & ADC BLOCK	V0.1
Date:	Monday, October 08, 2001	Sheet 3 of 11

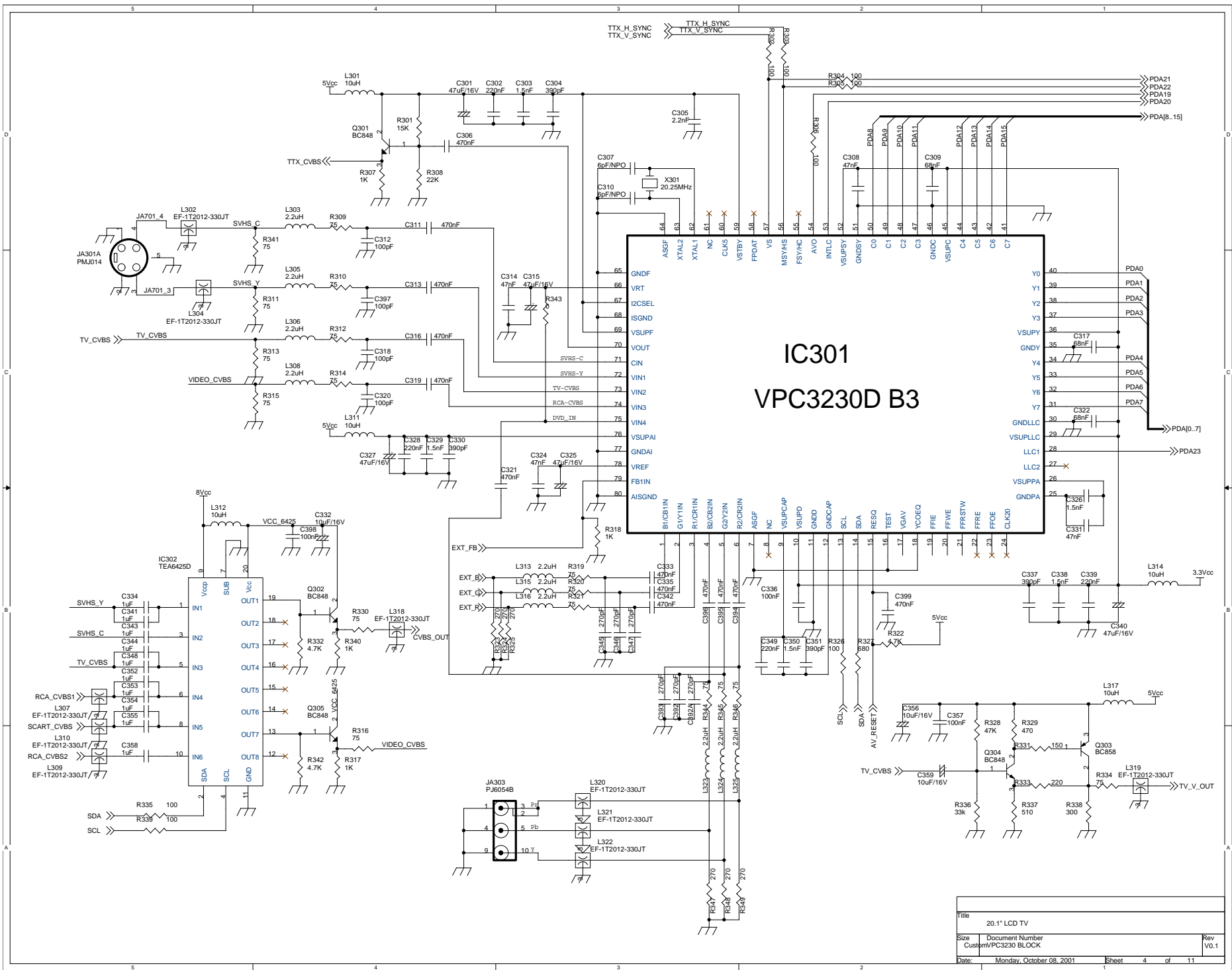

Title		20.1" LCD TV	
Size	Document Number	Custom/PC3230 BLOCK	
Date:	Monday, October 08, 2001	Sheet	4 of 11
Rev		V0.1	

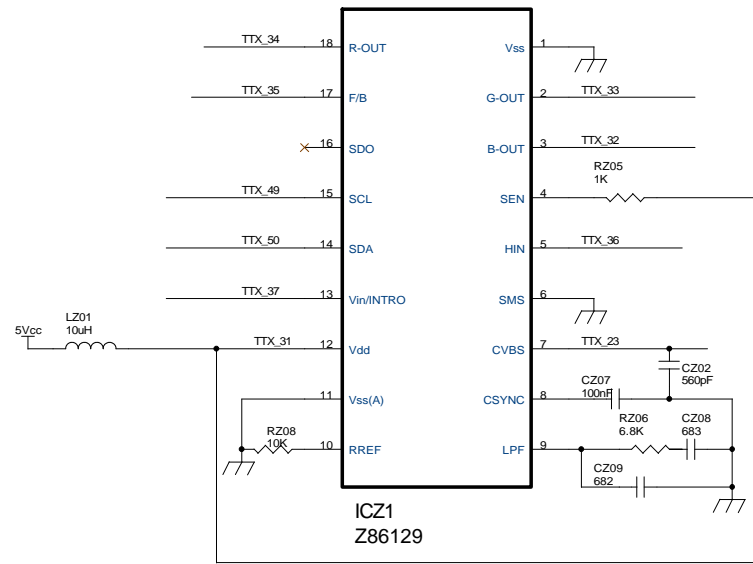
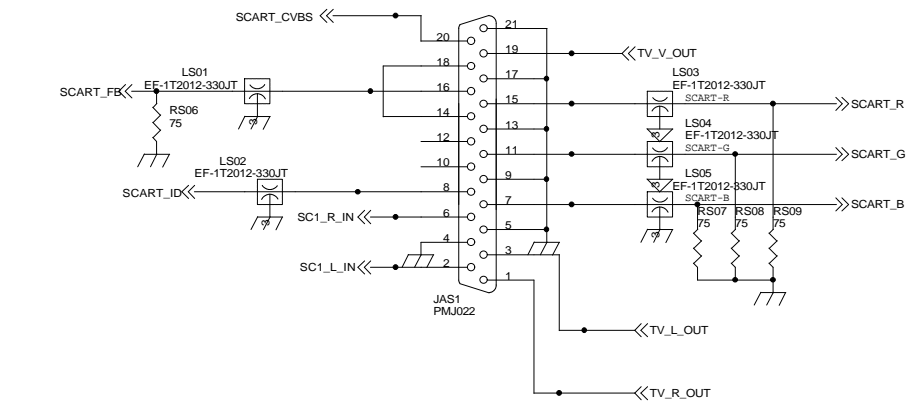
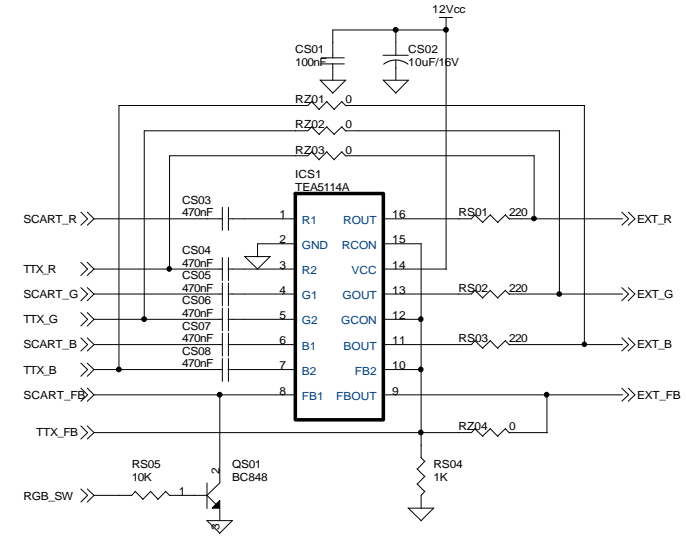
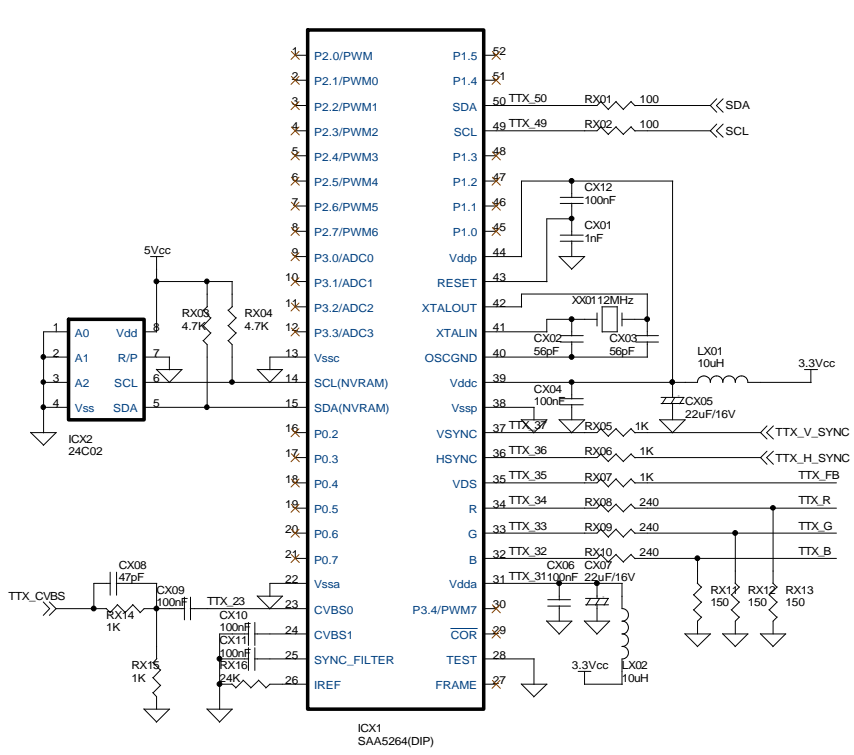

Title		
15.1" LCD TV		
Size	Document Number	Rev
A3	TTX_BLOCK	V0.1
Date:	Monday, October 08, 2001	Sheet 5 of 11

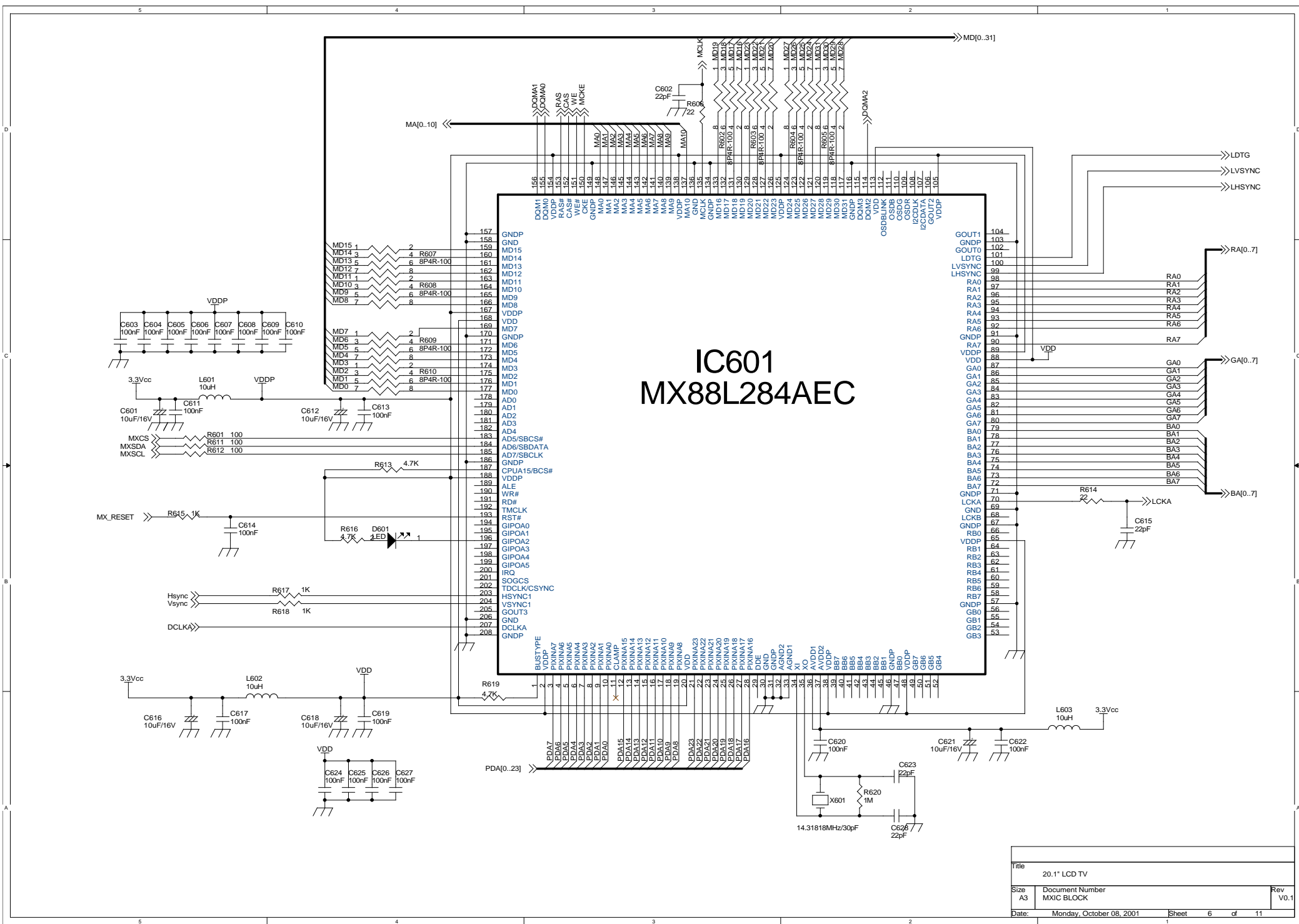

Title		
20.1" LCD TV		
Size	Document Number	Rev
A3	MXIC BLOCK	V0.1
Date:	Monday, October 08, 2001	Sheet 6 of 11

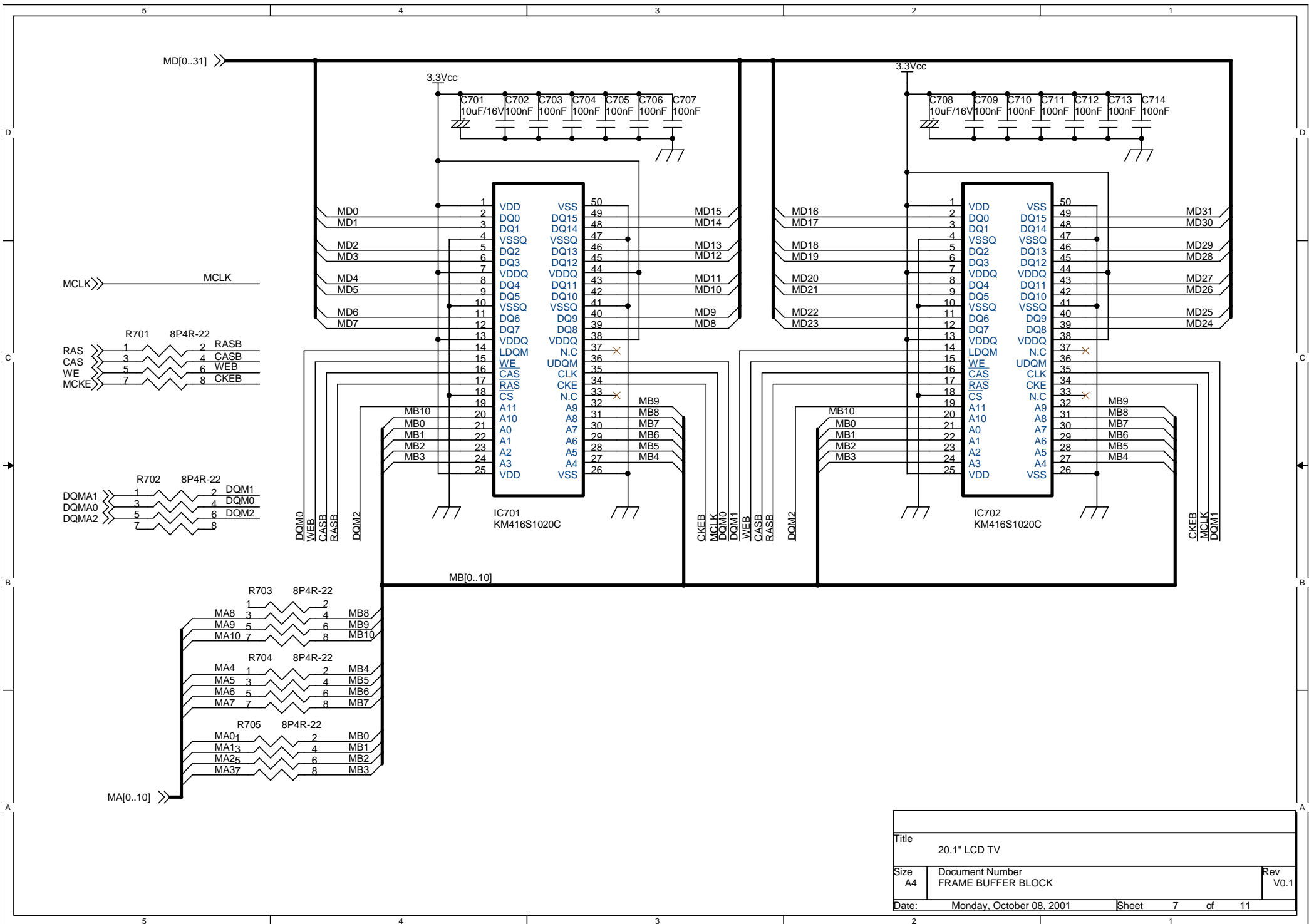

Title		
20.1" LCD TV		
Size	Document Number	Rev
A4	FRAME BUFFER BLOCK	V0.1
Date:	Monday, October 08, 2001	Sheet 7 of 11

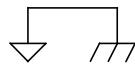
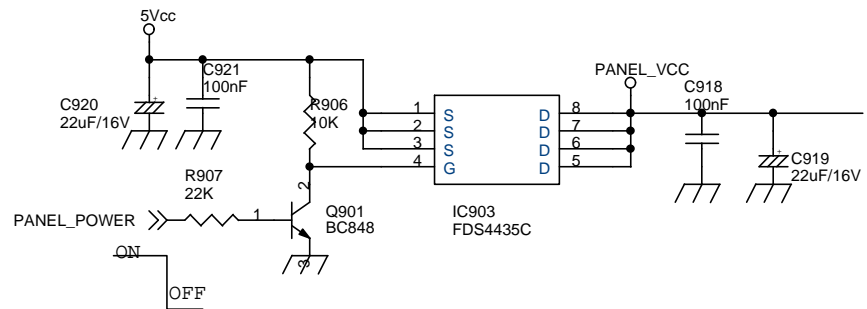
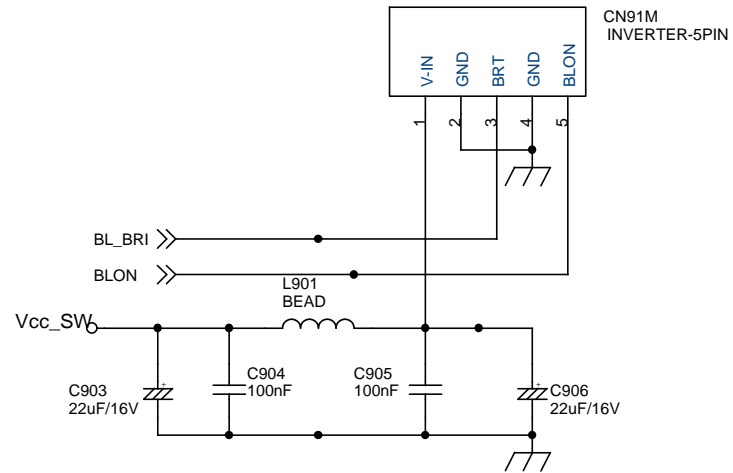
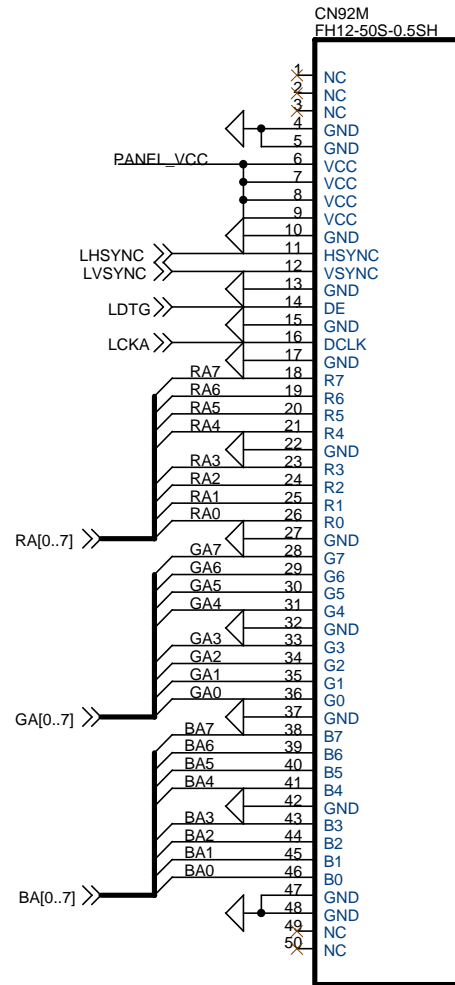

Title		
20.1" LCD TV		
Size	Document Number	Rev
A4	LVDS	V0.1
Date:	Monday, October 08, 2001	Sheet 8 of 11
2	1	

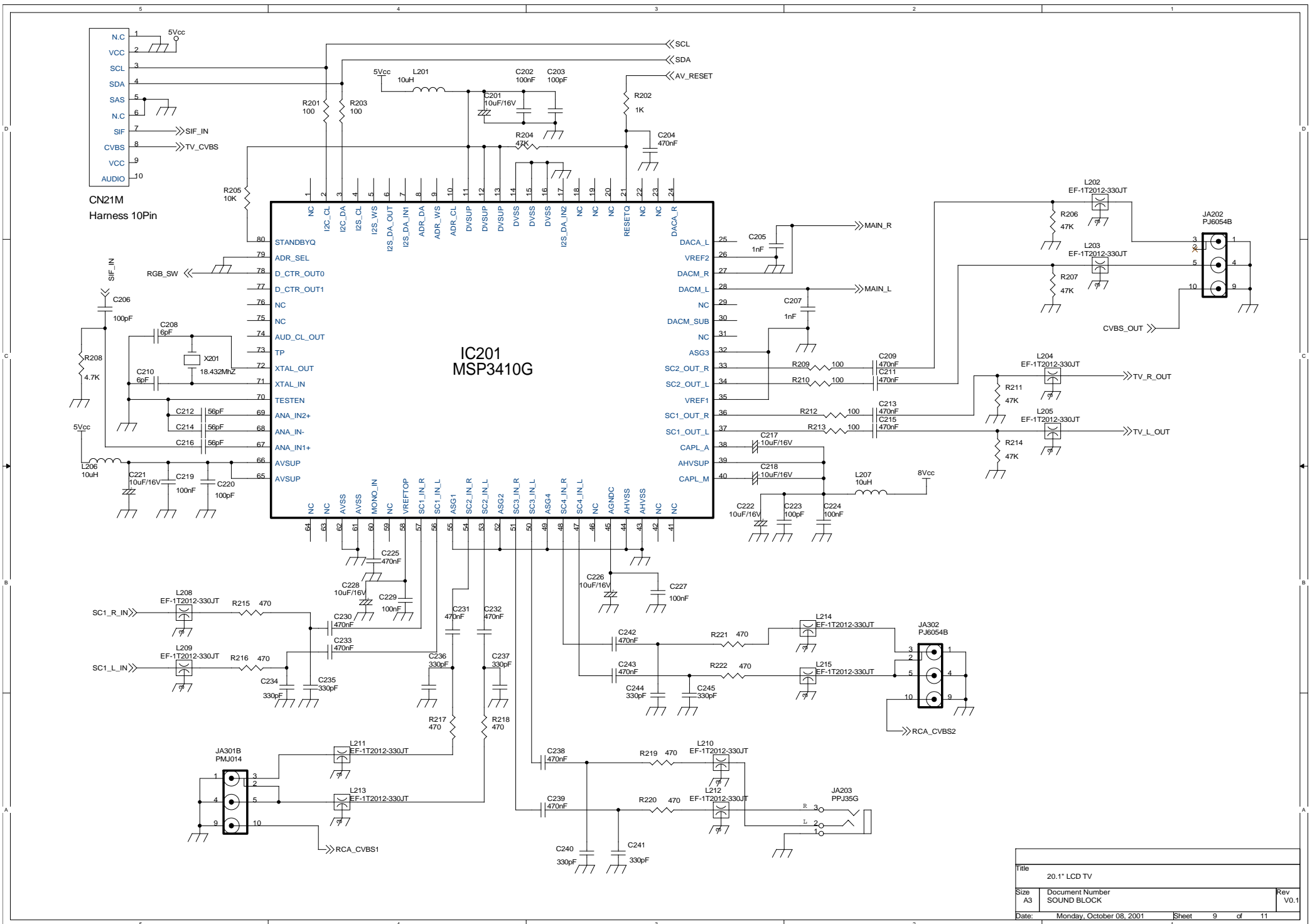

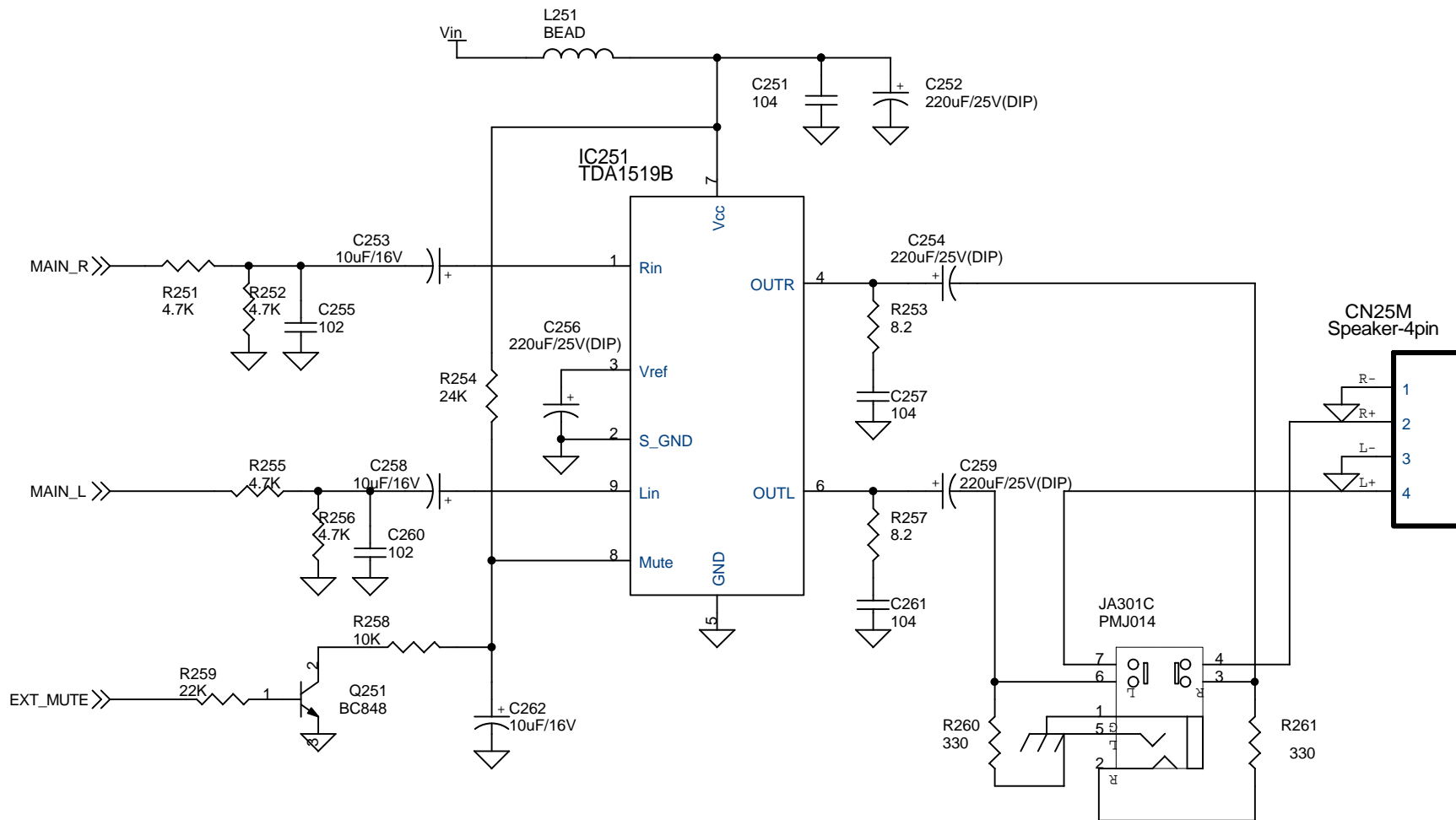

Title		
20.1" LCD TV		
Size	Document Number	Rev
A	SOUND AMP	V0.1
Date:	Monday, October 08, 2001	Sheet 10 of 11

6. General Specification

TVL-151N (NTSC System)

(1) Optical specification

Panel type : Active matrix colour TFT LCD

Display size : 15.1" (38 Cm) diagonal

Display colour : 16,777,216 colors

Pixel pitch : 0.3 mm(H) x 0.3 mm(W)

Resolution : 1024 x 768(XGA)

Back light : 4 CCFL lamps

Contrast ratio : 350 : 1(Typ)

Brightness : 400 Cd/m²(Typ)

Viewing angle : 45/45 degree(Up/Down), 60/60 degree(Left/Right)

(2) Electrical specification

PC signal input : Analog RGB input(0.714 Vp-p, 75 Ohms)

Video input : 1 Vp-p, 75 Ohms

Audio input : 500 mVrms, 10 Kohms

Television System : NTSC - M, PAL - M/N

TUNER : Frequency Synthesizer

Receiving Channel : VHF 2~13 CH,UHF 14~69CH, CATV 113 CH
(TOTAL 181 CH)

TV Stereo Sound(MTS) : STEREO, SAP, MONO

Surround System : ON/OFF

Closed Captions/ V-CHIP(Option)

Sound Speaker output : 1.5W x 2 stereo (Surround)

Power supply : AC/DC adapter

- AC 100V – 265V, 5A input

(3) Mechanical Specification

Dimension : 384mm x 377mm x 57mm(WxHxD)

Net Weight : 4.6 Kg

Gross weight : 5.5 Kg

Physical Rotation : 30 degree(Up), 5 degree(Down)

(4) Plug & Play : DDC-1/2B

(5) In/Out Terminals

- PC in :15 pin D-sub terminal
- Antenna in : 75 Ohm unbalanced DIN jack
- Audio/Video Out : RCA type phone jack
- Y/C video in : SVHS terminal
- Composite video in : RCA type phone jack
- Audio in(L,R) : RCA type phone jack
- PC sound input : Stereo Headphone jack

(6) Remote Controller

- Power
- Channel Up(Menu Up)
- Channel Down(Menu Down)
- Volume Up(Menu Right)
- Volume Down(Menu Left)
- Source Select(Enter with Menu mode)
- Digit entry keys(0 – 9)
- Menu
- Mute
- PC input select
- TV input select
- VIDEO input select
- SVHS input select
- Factory mode(available only in service remote controller)

(7) Menu OSD

- Picture
 - Brightness
 - Contrast
 - Color(invalid at PC input mode)
 - Sharpness(invalid at PC input mode)
 - Tint(invalid at PC input mode ,NTSC only)

- Sound
 - Bass
 - Treble
 - Balance
 - MTS

- Geometry(valid only at PC input mode)
 - H-position
 - V-position
 - H-size
 - V-size
 - Auto position

- Function
 - Tracking(valid only at PC input mode)
 - ◆ Auto Tracking
 - ◆ Clock Adjust
 - ◆ Phase Adjust
 - Information
 - Tuning(valid only at TV input mode)
 - ◆ Air/CAtv
 - ◆ Auto Tuning
 - ◆ Manual Tuning
 - Caption
 - ◆ CAPTION : ON/OFF
 - ◆ MODE : CAPTION/TEXT
 - ◆ CHANNEL : 1/2
 - ◆ FIELD : 1/2

 - V-CHIP
 - ◆ V-CHIP LOCK : ON
 - ◆ TV GUIDELINE
 - ◆ MPAA RATING]
 - ◆ CHAGE PIN

TVL-151M(PAL System)

(1) Optical specification

Panel type : Active matrix colour TFT LCD

Display size : 15.1" (38 Cm) diagonal

Display colour : 16,777,216 colours

Pixel pitch : 0.3 mm(H) x 0.3 mm(W)

Resolution : 1024 x 768(XGA)

Back light : 4 CCFL lamps

Contrast ratio : 350 : 1(Typ)

Brightness : 400 Cd/m²(Typ)

Viewing angle : 45/45 degree(Up/Down), 60/60 degree(Left/Right)

(2) Electrical specification

PC signal input : Analog RGB input(0.714 Vp-p, 75 Ohms)

Video input : 1 Vp-p, 75 Ohms

Audio input : 500 mVrms, 10 Kohms

TV Colour standard : PAL, SECAM(A/V NTSC)

TV Sound standard : B/G, I, D/K

TV Stereo Sound : Automatic German Stereo & NICAM digital stereo

Sound Speaker output : 1.5W x 2 stereo (Surround)

Power supply : AC/DC adapter

- AC 100V – 265V, 5A input

(3) Mechanical Specification

Dimension : 384mm x 377mm x 57mm(WxHxD)

Net Weight : 4.6 Kg

Gross weight : 5.5 Kg

Physical Rotation : 30 degree(Up), 5 degree(Down)

(4) Plug & Play : DDC-1/2B

(5) In/Out Terminals

- PC in :15 pin DSUB terminal
- Antenna in : 75 Ohm unbalanced DIN jack
- Audio/Video In/Out : 21 pin SCART terminal
- Y/C video in : SVHS terminal
- Composite video in : RCA type phone jack
- Audio in(L,R) : RCA type phone jack
- Audio line out(L,R) : RCA type phone jack
- PC sound input : Stereo Headphone jack

(6) Remote Controller

- Power
- Channel Up(Menu Up)
- Channel Down(Menu Down)
- Volume Up(Menu Right)
- Volume Down(Menu Left)
- Source Select(Enter with Menu mode)
- Digit entry keys(0 – 9)
- Menu
- Mute
- PC input select
- TV input select
- VIDEO input select
- SVHS input select
- Factory mode(available only in service remote controller)

(7) Menu OSD

- Picture
 - Brightness
 - Contrast
 - Colour(invalid at PC input mode)
 - Sharpness(invalid at PC input mode)
 - Tint(invalid at PC input mode ,NTSC only)
- Sound
 - Bass
 - Treble
 - Balance
 - MTS
- Geometry(valid only at PC input mode)
 - H-position

- V-position
- H-size
- V-size
- Auto position
- Function
 - Tracking(valid only at PC input mode)
 - ◆ Auto Tracking
 - ◆ Clock Adjust
 - ◆ Phase Adjust
 - Information
 - Tuning(valid only at TV input mode)
 - ◆ Sort
 - ◆ Auto tune
 - ◆ Manual Tune
 - ◆ Fine Tune
 - ◆ Ch. Skip
 - ◆ Colour system
 - ◆ Sound System

TVL-201N (NTSC System)

(1) Optical specification

Panel type : Active matrix color TFT LCD

Display size : 20.1" (51 Cm) diagonal

Display color : 16,777,216 colors

Pixel pitch : 0.6375 mm(H) x 0.6375mm

Resolution : 640 x 480(VGA)

Back light : 6 CCFL lamps

Contrast ratio : 400 : 1(Typ)

Brightness : 400 Cd/m²(Typ)

Viewing angle : 55/65 degree(Up/Down), 70/70 degree(Left/Right)

(2) Electrical specification

PC signal input : Analog RGB input(0.714 Vp-p, 75 Ohms)

Video input : 1 Vp-p, 75 Ohms

Audio input : 500 mVrms, 10 Kohms

Television System : NTSC - M, PAL - M/N

TUNER : Frequency Synthesizer

LNA(Low Noise Amp) : ON / OFF

Receiving Channel : VHF 2~13 CH,UHF 14~69CH, CATV 113 CH
(TOTAL 181 CH)

TV Stereo Sound(MTS) : STEREO, SAP, MONO

Surround System : ON/OFF

Closed Captions/ V-CHIP(Optional)

Sound Speaker output : 3W x 2 stereo (Surround)

Power supply : AC/DC adapter

- AC 100V – 265V, 7A input

(3) Mechanical Specification

Dimension : 513mm x 463mm x 67mm(WxHxD : Without Speaker)
654mm x 463mm x 67mm(WxHxD : With Speaker)

Net Weight : **** Kg

Gross weight : **** Kg

Physical Rotation : 30 degree(Up), 5 degree(Down)

(4) Plug & Play : DDC-1/2B

(5) In/Out Terminals

- PC in :15 pin D-sub terminal
- Antenna in : 75 Ohm unbalanced F-Connector
- Audio/Video Out : RCA type phone jack
- Y/C video in : SVHS terminal
- Composite video in : RCA type phone jack
- Component (Y,Cb,Cr)video in : RCA type phone jack
- Audio in(L,R) : RCA type phone jack
- PC sound input : Stereo Headphone jack

(6) Remote Controller

- Power
- Channel Up(Menu Up)
- Channel Down(Menu Down)
- Volume Up(Menu Right)
- Volume Down(Menu Left)
- Source Select(Enter with Menu mode)
- Digit entry keys(0 – 9)
- Menu
- Mute
- PC input select
- TV input select
- VIDEO input select
- SVHS input select
- Factory mode(available only in service remote controller)

(7) Menu OSD

- Picture
 - Brightness
 - Contrast
 - Color(invalid at PC input mode)
 - Sharpness(invalid at PC input mode)
 - Tint(invalid at PC input mode ,NTSC only)

- Sound
 - Bass
 - Treble
 - Balance
 - MTS

- Geometry(valid only at PC input mode)
 - H-position
 - V-position
 - H-size
 - V-size
 - Auto position

- Function
 - Tracking(valid only at PC input mode)
 - ◆ Auto Tracking
 - ◆ Clock Adjust
 - ◆ Phase Adjust
 - Information
 - Tuning(valid only at TV input mode)
 - ◆ Air/CATV
 - ◆ Auto Tuning
 - ◆ Manual Tuning
 - ◆ LNA : ON/OFF
 - Caption
 - ◆ CAPTION : ON/OFF
 - ◆ MODE : CAPTION/TEXT
 - ◆ CHANNEL : 1/2
 - ◆ FIELD : 1/2

 - V-CHIP
 - ◆ V-CHIP LOCK : ON
 - ◆ TV GUIDELINE
 - ◆ MPAA RATING]
 - ◆ CHAGE PIN

TVL-201M(PAL System)

(1) Optical specification

Panel type : Active matrix colour TFT LCD

Display size : 20.1" (51 Cm) diagonal

Display colour : 16,777,216 colours

Pixel pitch : 0.6375 mm(H) x 0.6375 mm

Resolution : 640 x 480(VGA)

Back light : 6 CCFL lamps

Contrast ratio : 400 : 1

Brightness : 400 Cd/m²

Viewing angle : 55/65 degree(Up/Down), 70/70 degree(Left/Right)

(2) Electrical specification

PC signal input : Analog RGB input(0.714 Vp-p, 75 Ohms)

Video input : 1 Vp-p, 75 Ohms

Audio input : 500 mVrms, 10 Kohms

TV Colour standard : PAL, SECAM(A/V:NTSC)

TV Sound standard : B/G, I, D/K

TV Stereo Sound : Automatic German Stereo & NICAM digital stereo

Sound Speaker output : 3W x 2 stereo

Power supply : AC/DC adapter

- AC 100V – 265V, 7A input

(3) Mechanical Specification

Dimension : 513mm x 463mm x 67mm(WxHxD : Without Speaker)

654mm x 463mm x 67mm(WxHxD : With Speaker)

Net Weight : **** Kg

Gross weight : **** Kg

Physical Rotation : 30 degree(Up), 5 degree(Down)

(4) Plug & Play : DDC-1/2B

(5) In/Out Terminals

- PC in :15 pin D-sub terminal
- Antenna in : 75 Ohm unbalanced DIN jack
- Audio/Video In/Out : 21 pin SCART terminal
- Y/C video in : SVHS terminal
- Composite video in : RCA type phone jack
- Component (Y,Cb,Cr)video in : RCA type phone jack
- Audio in(L,R) : RCA type phone jack
- Audio line out(L,R) : RCA type phone jack
- PC sound input : Stereo Headphone jack

(6) Remote Controller

- Power
- Channel Up(Menu Up)
- Channel Down(Menu Down)
- Volume Up(Menu Right)
- Volume Down(Menu Left)
- Source Select(Enter with Menu mode)
- Digit entry keys(0 – 9)
- Menu
- Mute
- PC input select
- TV input select
- VIDEO input select
- SVHS input select
- Factory mode(available only in service remote controller)

(7) Menu OSD

- Picture
 - Brightness
 - Contrast
 - Colour(invalid at PC input mode)
 - Sharpness(invalid at PC input mode)
 - Tint(invalid at PC input mode ,NTSC only)
- Sound
 - Bass
 - Treble
 - Balance

- MTS

- Geometry(valid only at PC input mode)
 - H-position
 - V-position
 - H-size
 - V-size
 - Auto position

- Function
 - Tracking(valid only at PC input mode)
 - ◆ Auto Tracking
 - ◆ Clock Adjust
 - ◆ Phase Adjust
 - Information
 - Tuning(valid only at TV input mode)
 - ◆ Sort
 - ◆ Auto tune
 - ◆ Manual Tune
 - ◆ Fine Tune
 - ◆ Ch. Skip
 - ◆ Colour system
 - ◆ Sound System

7. Troubleshooting 1

If you have a problem setting up or using your LCD monitor, you may be able to solve it yourself. Before contacting customer service, try the suggested actions that are appropriate to your problem.

What you see...	Suggested Actions	Reference
Screen is blank and power indicator is off	<ul style="list-style-type: none"> ● Ensure that the power cord is firmly connected and the LCD monitor is on. 	Connecting a PC, See the manual
“CHECK CABLE OR SIGNAL” message	<ul style="list-style-type: none"> ● Ensure that the signal cable is firmly connected to the PC or video sources. ● Ensure that the PC or video sources are turned on. 	Connecting a PC, TV or VCR, See the manual
“INVALID MODE” message	<ul style="list-style-type: none"> ● Check the maximum resolution and the frequency of the video adaptor. ● Compare these values with the data in the Display Modes Timing Chart. 	PC Stable Adjustment, APPENDIX D:Display Modes See the manual
The image is too light or too dark	<ul style="list-style-type: none"> ● Adjust the Brightness and Contrast. 	BRIGHTNESS, CONTRAST. See the manual
Horizontal bars appear to flicker, jitter or shimmer on the image	<ul style="list-style-type: none"> ● Adjust the Clock function. ● Auto Tracking will clear it automatically. 	PC Stable Adjustment. See the manual
Vertical bars appear to flicker, jitter or shimmer on the image.	<ul style="list-style-type: none"> ● Adjust the Phase function and then adjust the Clock function. ● Auto Tracking will clear it automatically. 	
Screen is blank and power indicator light is steady amber or blinks every 0.5 or 1 seconds	<ul style="list-style-type: none"> ● The monitor is using its power management system. ● Move the computer' s mouse or press a key on the keyboard 	APPENDIX A : Power Saver, See the manual
Image is not stable and may appear to vibrate	<ul style="list-style-type: none"> ● Auto tracking will clear it automatically ● Check that the display resolution and frequency from your PC or video board is an available mode for your monitor. On your computer check : Control Panel, Display, Settings 	PC Stable Adjustment, See the manual
	<ul style="list-style-type: none"> ● Horizontal frequency ● Vertical frequency ● Maximum refresh rate 	31 KHz - 69KHz 56Hz - 85Hz 1024 x 768 @85Hz
Image is not centered on the screen.	<ul style="list-style-type: none"> ● Auto Position will set the best position automatically ● Adjust the horizontal and vertical position. 	AUTO POSITION, H-POSITION, V-POSITION, See the manual

7. Troubleshooting 2

Problem	Suggested Actions	Reference
No sound	<ul style="list-style-type: none"> ● Ensure that the audio cable is firmly connected to both the audio-in jack on your monitor and the audio-out jack on your sound card. 	Connecting a PC, TV or VCR, See the manual
	<ul style="list-style-type: none"> ● Check the volume level 	Adjusting the Sound settings, See the manual
Sound level is too low	<ul style="list-style-type: none"> ● Check the volume level 	
	<ul style="list-style-type: none"> ● If the volume is still too low after turning the control to its maximum, check the volume control on the computer sound card or software program. 	Refer to your computer, sound card or software documentation.
Sound is too high pitched or too low pitched	<ul style="list-style-type: none"> ● Adjust the Treble and Bass to appropriate level. 	Adjusting the Sound Settings, See the manual
TV signal is not received	<ul style="list-style-type: none"> ● Ensure that the antenna cable is firmly connected to the VHF/UHF jack. 	Connecting to watch TV or VCR, See the manual
	<ul style="list-style-type: none"> ● Check "Channel Memory" and make sure you choose the correct channel system. (PAL Model) 	Channel Memory, See the manual
	<ul style="list-style-type: none"> ● Select "Auto Tuning" to configure the channel system automatically.(PAL Model) 	
	<ul style="list-style-type: none"> ● Check AIR/CATV is correctly selected on screen display menu. (NTSC Model) 	Selecting Broadcast Source, See the manual

8. 15.1" TFT LCD TV Parts List

Date : 2002. 2. 26

NO	Spec	Pak'	Usa'	Location No	etc
ASS'Y, PACKING					
1	MANUAL, INSTRUCTION		1		
2	REMOCON ASS'Y, PAL BLACK		1		
3	PACKING CASE, B SK*K180*K180		1		
4	HANDLE, NYLON		1		
5	HANDLE BRACKET, NYLON		1		
6	PACKING CASE, B K180*K180		1		
7	CUSHION(TOP), E.P.S #20 60		1		
8	CUSHION(BOTTOM), E.P.S #20 60		1		
9	SET COVER, VINYL		1		
10	DC ADAPTER, 12V 5A		1		
11	POWER CABLE		1		
12	15PIN D - SUB CABLE		1		
13	BATTERY		2		
14	WARRANTY CARD		1		
ASS'Y, STAND					
1	STAND FRAME, E.G.I(t=2.0mm)	NATURAL	1		
2	STAND LEG, ABS HF - 380 #15951	SILVER	1		
3	SCREW STAND LEG	BLACK	4		
4	HINGE(L), KKH1T201		1		
5	SCREW HINGE(L), M4+10	BLACK	2		
6	HINGE(R), KKH1T202		1		
7	SCREW HINGE(R), M4+10	BLACK	2		
8	STAND COVER(FRONT), ABS HF - 380 #15951	SILVER	1		
9	STAND COVER(REAR), ABS HF - 380 #15951	SILVER	1		
10	SCREW STAND, KTB4+12G	BLACK	2		
11	SPONGE, RUBBER(t=2.0mm 16MM)	WHITE	2		
12	BOTTOM FRAME, E.G.I(t=1.0mm)	NATURAL	1		
13	SCREW BOTTOM FRAME, KTB4+12G	BLACK	4		
14	SPONGE, RUBBER(t=2.0mm 20MM)	WHITE	4		
15	SCREW, KTB4+12G	BLACK	8		
ASS'Y, REAR COVER					
1	REAR COVER, ABS GP35 #130035		1		
2	PAINT, TS - 519S				
3	SCREW, KTB4+12G	BLACK	5		
4	TUNER PCB ASS'Y(PAL)		1		
5	SCREW, KTW3+8G		3		
6	SCREW, KTB4+12G	BLACK	8		

NO	Spec	Pak'	Usa'	Location No	etc
7	STAND COVER, ABS GP35 #130035		1		
8	SCREW STAND COVER, KTB4+12G	BLACK	4		
9	AV TERMINAL SHEET, PC(t=0.3mm)	GRAY	1		
10	MODEL NAME PLATE, PC(t=0.3mm)	GRAY	1		
	ASS'Y, FRONT PANEL				
1	FRONT PANEL ASS'Y, KKY1T201ZA2ZA1		1		
2	FRONT ASS'Y, KKY1T201ZA2A1		1		
3	FRONT PAINT, KKY1T201ZA2		1		
4	FRONT, ABS HF-380 #15951		1		
5	PAINT, TS-529S-Y				
6	PAINT, TS-501S				
7	MASKING SHEET, PAPER TAPE		1		
8	WINDOWS FILTER, ACRYL 855M #41791		1		
9	LED PCB ASS'Y		1		
10	SCREW, KTW3+8G	BLACK	2		
11	KNOB ASS'Y, KBT1M202ZA1		1		
12	KNOBE, ABS HF-380 #15951	WHITE	1		
13	CONTROL PCB ASS'Y		1		
14	SCREW, KTW3+8G	BLACK	3		
15	SCREW, KTB4+12G	BLACK	2		
16	SPEAKER	1.5W	2		
17	SCREW, KTB4+12G	BLACK	8		
18	LCD PANEL, LC151X01-A3(15.1INCH)	400cd	1		
19	SHIELD CASE, E.G.(t=1.0)	NATURAL	1		
20	MAIN PCB ASS'Y(PAL)				
21	SCREW, KTW3+8G		8		
22	SCREW, KTB4+12G		10		
23	EMI SPONGE, 10X70X5(TAPE)		1		
24	EMI SPONGE, 10X70X10(TAPE)		1		
25	AV TER. BRACKET, ABS GP35 #130035		1		
26	SCREW, M3+6G()		3		
27	INVERTER PCB ASS'Y		1		
28	SCREW, KTW3+8G		2		
29	EMI SHIELD CASE, KKC1T202		1		
30	EMI BRACKET, KKC1T203		1		
31	SCREW EMI SHIELD CASE, KTB3+4G		6		
32	HARNESS, SPEAKER / 4Pin	SPEAKER	1		11/26
33	LCD CABLE, 151M 110mm	LCD	1		11/26
34	INVERTER CABLE, 10Pin-6Pin 130mm	INVERTER	1		11/26
	PCB ASS'Y, MAIN TVL_151M (SMD)				
1	CHIP RES', 1/10W, 1.3K OHM J	1608	1	R015	

NO	Spec	Pak'	Usa'	Location No	etc
2	CHIP RES', 1/10W, 10 OHM J	1608	3	R360,R363,R366	
3	CHIP RES', 1/10W, 100 OHM J	1608	27	R005,R008,R016,R017,R201,R203,R209,R210,R212,R213,R302,R303,R304,R305,R306,R326,R335,R339,R601,R611,R612,R901,RX01,RX02,R375	
				R606,R614	
4	CHIP RES', 1/10W, 180K OHM J	1608	2	R252,R257	
5	CHIP RES', 1/10W, 10K OHM J	1608	8	R004,R007,R205,R253,R254,R801,R902,R906	
6	CHIP RES', 1/10W, 150 OHM J	1608	4	R331,RX11,RX12,RX13	
7	CHIP RES', 1/10W, 15K OHM J	1608	2	R006,R301	
8	CHIP RES', 1/10W, 1K OHM J	1608	22	R001,R013,R014,R018,R019,R025,R202,R260,R261,R307,R318,R340,R369,R371,R615,R617,R618,RX05,RX06,RX07,RX14,RX15	
9	CHIP RES', 1/10W, 1M OHM J	1608	1	R620	
10	CHIP RES', 1/10W, 2.7K OHM J	1608	2	R002,R003	
11	CHIP RES', 1/10W, 22 OHM J	1608	4	R378,R379,R381,R382	
12	CHIP RES', 1/10W, 220 OHM J	1608	6	R022,R023,R333,RS01,RS02,RS03	
13	CHIP RES', 1/10W, 22K OHM J	1608	5	R009,R255,R308,R802,R907	
14	CHIP RES', 1/10W, 240 OHM J	1608	3	RX08,RX09,RX10	
15	CHIP RES', 1/10W, 24K OHM J	1608	1	RX16	
16	CHIP RES', 1/10W, 270 OHM J	1608	3	R323,R324,R325	
17	CHIP RES', 1/10W, 3.3K OHM J	1608	5	R373,RS05,RS10,RS11,RS12	
18	CHIP RES', 1/10W, 300 OHM J	1608	1	R338	
19	CHIP RES', 1/10W, 330 OHM J	1608	2	R258,R259	
20	CHIP RES', 1/10W, 33K OHM J	1608	1	R336	
21	CHIP RES', 1/10W, 4.7K OHM J	1608	12	R020,R021,R024,R208,R322,R332,R380,R383,R613,R619,RX03,RX04	
22	CHIP RES', 1/10W, 470 OHM J	1608	8	R215,R216,R217,R218,R219,R220,R329,C602	
23	CHIP RES', 1/10W, 47K OHM J	1608	11	R010,R011,R012,R204,R206,R207,R211,R214,R251,R256,R328	
24	CHIP RES', 1/10W, 510 OHM J	1608	2	R337,R903	
25	CHIP RES', 1/10W, 680 OHM J	1608	3	R327,R376,R377	
26	CHIP RES', 1/10W, 75 OHM J	1608	22	R309,R310,R311,R312,R313,R314,R315,R316,R317,R319,R320,R321,R330,R334,R341,R361,R364,R368,RS06,RS07,RS08,RS09	
27	CHIP RES' ARRAY 8P4R - 100 OHM J	1608	19	R362,R365,R367,R370,R372,R374,R602,R603,R604,R605,R607,R608,R609,R610	
				R701,R702,R703,R704,R705	
29	CHIP CAP' 16V 0.47uF Z	1608	28	C204,C209,C211,C213,C215,C225,C230,C231,C232,C233,C238,C239,C306,C311,C313,C316,C319,C321,C333,C335,C342,C399,CS03,CS04,CS05	
				CS06,CS07,CS08	
30	CHIP CAP' 16V 1uF Z	1608	5	C334,C343,C348,C353,C355	
31	CHIP CAP' 25V 0.0015uF Z	1608	5	C303,C326,C329,C338,C350	
32	CHIP CAP' 25V 0.001uF Z	1608	5	C001,C004,C205,C207,CX01	
33	CHIP CAP' 25V 0.0022uF Z	1608	1	C305	
34	CHIP CAP' 25V 0.0039uF Z	1608	1	C384	
35	CHIP CAP' 25V 0.039uF Z	1608	1	C385	
36	CHIP CAP' 25V 0.047uF Z	1608	7	C308,C314,C324,C331,C379,C380,C382	
37	CHIP CAP' 25V 0.068uF Z	1608	3	C309,C317,C322	
38	CHIP CAP' 25V 0.1uF Z	1608	90	C002,C006,C009,C202,C219,C224,C227,C229,C251,C336,C357,C358,C361,C362,C365,C366,C367,C368,C370,C371,C373,C374,C375,C376,C377	
				C386,C387,C390,C398,C603,C604,C605,C606,C607,C608,C609,C610,C611,C613,C614,C617,C619,C620,C622,C624,C625,C626,C627,C702,C703	
				C704,C705,C706,C707,C709,C710,C711,C712,C713,C714,C802,C804,C805,C808,C810,C812,C814,C816,C818,C901,C902,C904,C905,C907,C908	
				C909,C910,C911,C914,C918,C921,C923,CS01,CX04,CX06,CX09,CX10,CX11,CX12,C820	
39	CHIP CAP' 25V 0.22uF Z	1608	4	C302,C328,C339,C349	

NO	Spec	Pak'	Usa'	Location No	etc
40	CHIP CAP' 25V 100pF J	1608	9	C203,C206,C220,C223,C312,C318,C320,C323,C397	
41	CHIP CAP' 25V 10pF J	1608	3	C378,C381,C383	
42	CHIP CAP' 25V 22pF J	1608	2	C623,C628	
43	CHIP CAP' 25V 270pF J	1608	3	C345,C346,C347	
44	CHIP CAP' 25V 330pF J	1608	8	C234,C235,C236,C237,C240,C241,C389,C391	
45	CHIP CAP' 25V 33pF J	1608	2	C007,C008	
46	CHIP CAP' 25V 390pF J	1608	4	C304,C330,C337,C351	
47	CHIP CAP' 25V 47pF J	1608	1	CX08	
48	CHIP CAP' 25V 56pF J	1608	5	C212,C214,C216,CX02,CX03	
49	CHIP CAP' 25V 6pF J	1608	4	C208,C210,C307,C310	
50	CHIP COIL 10uH	2012	19	L001,L201,L206,L207,L301,L311,L312,L314,L317,L360,L361,L362,L601,L602,L603,L902,L904,LX01,LX02	
51	CHIP COIL 2.2uH	2012	8	L303,L305,L306,L308,L310,L313,L315,L316	
52	CHIP COIL CHOKE, 47uH	SMD	1	L804	
53	CHIP DIODE, DAN217	SOT-23	2	D360,D361	
54	CHIP DIODE, MBRS340	SMC	1	D801	
55	CHIP EMI FILTER, EF-1T2012-330JT	2012	31	L202,L203,L204,L205,L208,L209,L210,L211,L212,L213,L302,L304,L307,L309,L318,L319,L363,L364,L365,L366,L367,L368,L369,L370 LS01,LS02,LS03,LS04,LS05,L253,L254	
56	CHIP TR, BC848B	SOT-23	12	Q001,Q002,Q251,Q301,Q302,Q304,Q801,Q901,QS01,QS02,QS03,QS04	
57	CHIP TR, BC858B	SOT-23	1	Q303	
58	SMD WAFER, 125HR-20MT / 20Pin	SMD	1	CN92M	
59	IC LOGIC, 74F14FC	SOIC	1	IC362	
60	IC ADC, AD9883A	MQFP-128	1	IC360	
61	FET, FDS4435C	SOP-J8	2	IC802,IC903	
62	REGULATOR, KIA7808AF	D'PACK	1	IC805	
63	REGULATOR, KIA78DL05F	D'PACK	1	IC801	
64	REGULATOR, LD1117DT33	D'PACK	2	IC361,IC902	
65	REGULATOR, SI-8050SD	TO-263	1	IC803	
66	REGULATOR, RC1587M33	TO-263	1	IC804	
67	IC AUDIO, MSP3410G-B8	PQFP-80	1	IC201	
68	IC IMAGE SCALLER, MX88L284AEC	QFP-282	1	IC601	
69	IC LVDS, Si1164CT64 / 64Pin	TQFP	1	IC901	
70	IC AUDIO AMP, TDA8542AT / 20Pin	SOP	1	IC251	
71	IC VIDEO, VPC3230D-B3	PQFP-80	1	IC301	
72	CHIP X-TAL, 12MHz / 33pF	SMD	2	XX01,X001	
73	CHIP X-TAL, 14.31818MHz / 30pF	SMD	1	X601	
74	CHIP X-TAL, 18.432MHz / 15pF	SMD	1	X201	
75	CHIP X-TAL, 20.25MHz / 15pF	SMD	1	X301	
76	IC RESET, KIA7042	SOT-89	1	IC003	
77	IC MEMORY, HY57V161610	SOP-50	2	IC701,IC702	
78	PCB MAIN, P151AM-01	FR-4/4LAYER	1		
PCB ASS'Y, MAIN TVL_151M (RAD)					
79	ELEC' CAP, 16V 220uF	5mm	8	C252,C801,C806,C807,C809,C811,C813,C815	

NO	Spec	Pak'	Usa'	Location No	etc
80	ELEC' CAP, 16V 22uF	5mm	7	C903,C906,C913,C919,C920,CX05,CX07	
81	ELEC' CAP, 16V 47uF	5mm	9	C254,C301,C315,C325,C327,C340,C803,C817,C819	
82	ELEC' CAP, 50V 10uF	5mm	31	C003,C005,C010,C201,C217,C218,C221,C222,C226,C228,C256,C257,C332,C356,C359,C360,C363,C364,C369,C372,C601,C612,C616,C618,C621	
				C701,C708,C912,C917,C922,CS02	
83	ELEC' CAP, 50V 1uF	5mm	2	C235,C255	
PCB ASS'Y, MAIN TVL_151M (AXI)					
84	BEAD CORE, 3X5	3X5	5	L251,L801,L802,L803,L901	
85	FUSE, R251 010		1	F801	
PCB ASS'Y, MAIN TVL_151M (M/I)					
86	IC VIDEO S/W, TEA6425	DIP	1	IC302	
87	IC RGB S/W, TEA5114A	DIP	1	ICS1	
88	IC MICOM, S3P863AXZZ / OTP	DIP	1	IC001	
89	IC EEPROM, 24C16	DIP	1	IC002	
90	IC TTX, SAA5264	DIP	1	ICX1	
91	IC EEPROM, 24C02	DIP	1	ICX2	
92	WAFER, 53014-0310 / 3Pin Straight	53014-0310	1	CN03M	
93	WAFER, 53014-0410 / 4Pin Straight	53014-0410	1	CN25M	
94	WAFER, 53014-0510 / 5Pin Straight	53014-0510	1	CN01M	
95	WAFER, 53014-0610 / 6Pin Straight	53014-0610	1	CN91M	
96	HARNESS, Tuner / 10Pin 300mm		1	CN21M	
97	JACK PIN, PJ6054T(SHIELD)		1	JA202	
98	JACK PHONE, PPJ35G		1	JA203	
99	JACK PIN-BLOCK, PMJ014T(SHIELD)		1	JA360	
100	JACK D-SUB, PDC013		1	JA013	
101	JACK DC, PDJ005		1	JA801	
102	JACK SCART, PMJ002		1	JAS1	
103	IC SOCKET, WSDIF-42T-1.778		1	IC001	
PCB ASS'Y, TUNER TVL_151M (RAD)					
1	ELEC' CAP, 16V 100uF	5mm	1	CT01	
PCB ASS'Y, TUNER TVL_151M (AXI)					
2	RES' CARBON, 1/6W 100 OHM J		2	RT01,RT02	
3	COIL, 10uH / AL03		1	LT01	
4	CERAMIC CAP, 0.1uF	CA2644	1	CT02	
5	PCB TUNER, P151AT-01	FR-1	1		
PCB ASS'Y, TUNER TVL_151M (M/I)					
6	WAFER, 53014-1010 / 10Pin Straight	53014-1010	1	CN21T	
7	TUNER, TCPQ9091PD27D(S)	SAMSUNG	1	TU01	

NO	Spec	Pak'	Usa'	Location No	etc
PCB ASS'Y, LED TVL_151M (AXI)					
1	CERAMIC CAP, 0.1uF J	CA2644	1	CC03	
2	RES' CARBON, 1/6W 47 OHM J	AXIAL	1	RC01	
3	RES' CARBON, 1/6W 47K OHM J	AXIAL	1	RC02	
4	RES' CARBON, 1/6W 680 OHM J	AXIAL	2	RC08, RC09	
PCB ASS'Y, LED TVL_151M (M/I)					
5	HARNESS, LED / 5Pin 250mm	2mm	1	CN01C	
6	LED DUAL, SAM5270		1	DL01	
7	REMOCON RECIEVER, FRP -3051		1	RM01	
PCB ASS'Y, SW TVL_151M (AXI)					
1	RES' CARBON, 1/6W 390 OHM J	AXIAL	2	RC06,RC07	
2	RES' CARBON, 1/6W 620 OHM J	AXIAL	1	RC05	
3	RES' CARBON, 1/6W 1.3K OHM J	AXIAL	1	RC04	
4	RES' CARBON, 1/6W 2.2K OHM J	AXIAL	1	RC03	
5	SW TACT, HST -0260A	5mm	7	SW01,SW02,SW03,SW04,SW05,SW06,SW07	
	PCB S/W, P151AS-01	FR-1	1		
PCB ASS'Y, SW TVL_151M (M/I)					
6	HARNESS, SW / 3Pin 100mm	2mm	1	CN03C	

8. 20.1" TFT LCD TV Part List

NO	Spec	Pak'	Usa'	Location No	etc
ASS'Y, PACKING					
1	MANUAL, INSTRUCTION		1		
2	REMOCON ASS'Y, PAL NEW		1		
3	PACKING CASE, B SK*K180*K180		1		
4	PACKING CASE, A SK*K180*K180				
6	PACKING CASE, B K180*K180		1		
7	CUSHION(TOP), E.P.S #20 60		1		
8	CUSHION(BOTTOM), E.P.S #20 60		1		
9	SET COVER, VINYL , 650*650		1		
10	DC ADAPTER, 15V 5.3A		1		
11	POWER CABLE		1		
12	15PIN D-SUB CABLE		1		
13	BATTERY		2		
14	WARRANTY CARD		1		
15	AUDIO CABLE, 2M		1		
16	SERIAL NO. LABEL				
ASS'Y, STAND					
1	SPONGE BOTTOM , RUBBER 20*2t		6		
2	SPONGE STAND , RUBBER 16*2t		2		
3	SCREW STAND COVER FRONT , BH T4*12 BLK		2		
4	STAND COVER FRONT , ABS HF380 #15951, TS-529S-Y		1		
5	STAND COVER REAR , ABS HF380 #15951, TS-529S-Y		1		
6	SCREW HINGE(L/R)+STAND FRAME , BH M4*10 BLK		4		
7	HINGE (RIGHT)		1		
8	HINGE (LEFT)		1		
9	BOTTOM FRAME , SPC 3.0t 346*210 (250T)		1		
10	SCREW BTM FRAME+ STAND LEG , BH T4*12 BLK		6		
11	SCREW STAND FRAME+STAND LEG , BH T4*12 BLK		5		
12	STAND FRAME , SPC 3.0t 360*280 (250T, 110T)		1		
13	STAND LEG , ABS HF380 #15951, TS-529S-Y		1		
ASS'Y, REAR COVER					
1	SCREW HINGE BKT + SHIELD CASE		2		
2	HINGE BRAKET , ABS GP35 # 130035		1		
3	SCREW TUNER COVER , BH T4*12 BLK		1		
4	TUNER COVER , ABS GP35#130035		1		
5	TUNER PCB ASS'Y		1		
6	SCREW TUNER PCB , PH T3*8		3		
7	SCREW REAR COVER , BH T4*12 BLK		10		
8	REAR COVER , ABS GP35#130035		1		
9	CONTROL SHEET , PC 0.3t		1		
10	MODEL NAME PLATE , PC 0.3t		1		
ASS'Y, FRONT PANEL					
1	FRONT PANEL , ABS HF-380 #15951		1		
2	SCREW LED , PH T3*8		2		
3	LED PCB ASS'Y		1		
4	WINDOW FILTER , ACRYLIC 855M #41791		1		
5	SCREW LED , PH T3*8		3		
6	CONTROL PCB ASS'Y		1		
7	KNOB , ABS HF380 #15951		1		
8	SCREW KOB + FRONT PANEL , BH T4*12 BLK		2		
9	FRONT PANEL , ABS HF-380 #15951, TS-529S-Y		1		

NO	Spec	Pak'	Usa'	Location No	etc
10	LCD FLAT CABLE, 201M 200mm	LCD	1		
11	LCD PANEL, LC201V1(20.1INCH)	400cd	1		
12	SCREW EMI, BH TAPITTE 3*4		11		
13	EMI BRAKET		1		
14	EMI SHIELD CAES		1		
15	PEM NUT 4, 8.3 * 7 TAP3		5		
17	PEM NUT 3, 19.8 * 7 TAP3 DP15		2		
18	PEM NUT 2, 30.9 * 8 TAP4 DP15		1		
19	PEM NUT 3, 33.4 * 9 TAP4 DP15		4		
20	SHIELD CASE, SECC 1.2t 517*410 (250T)		1		
21	SCREW SHIELD CASE + FR/PANEL, BH T4*12 BLK		10		
22	INVERTER PCB ASSY, 6632Z-2001A		1		
23	INVERTER CABLE, 12Pin-6Pin 180mm	INVERTER	1		
24	SCREW INVERTER PCB, PH T3*8		3		
25	SCREW MAIN PCB, PH T3*8		8		
26	MAIN PCB ASSY(PAL)		1		
27	AV TERMINAL BRAKET, ABS GP35 #130035		1		
28	SCREW AV TER BKT + SHIELD CASE, BH M3*6		3		
29	SCREW SHIELD CASE + LCD PANEL, M3*12 BLK		4		
30	ST COVER PCB ASSY		1		
31	SCREW CT COVER PCB, PH T3*8		2		
	ASSY, ST COVER				
32	STAND COVER, ABS GP35#130035		1		
33	SCREW STAND COVER, BH T4*12 BLK		4		
34	SCREW HINGE(L/R)-SHIELD CASE		8		
	ASSY, SPEAKER				
35	SPEAKER FRONT, HIPS HI-425TVG#1600 TS-529S-Y		2		
36	SPEAKER REAR(R), HIPS HI-425TVG#1600 TS-529S-Y		1		
37	SPEAKER REAR(L), HIPS HI-425TVG#1600 TS-529S-Y		1		
38	SPEAKER REAR PANEL INSERT NUT, M4 * 8*6		8		
39	SCREW, BT 4T*12 BLK		28		
40	SCREW, BT 3*8		4		
41	MAIN SPEAKER, MST-57BR20T		2		
42	TWITTER SPEAKER, MSF-2D4SB53T		2		
43	SPEAKER PCB ASSY		2		
44	SPEAKER WIRE, 1WIRE		2		
	PCB ASSY, MAIN TVL_201M (SMD)				
1	CHIP RES, 1/10W, 8.2 OHM J	1608	2	R253,R257	
2	CHIP RES, 1/10W, 10 OHM J	1608	3	R360,R363,R366	
3	CHIP RES, 1/10W, 22 OHM J	1608	5	R375,R378,R379,R381,R382	
4	CHIP RES, 1/10W, 75 OHM J	1608	30	RS06,RS07,RS08,RS09,R309,R310,R311,R312,R313,R314,R315,R316,R319,R320,R321,R330,R334,R341,R344,R345,R346,R347,R348,R349,R350,R351,R352	
				R361,R364,R368	
5	CHIP RES, 1/10W, 100 OHM J	1608	25	RX01,RX02,R005,R008,R016,R017,R201,R203,R209,R210,R212,R213,R302,R303,R304,R305,R306,R326,R335,R339,R601,R606,R614,R611R612	
6	CHIP RES, 1/10W, 150 OHM J	1608	4	RX11,RX12,RX13,R331	
7	CHIP RES, 1/10W, 220 OHM J	1608	6	RS01,RS02,RS03,R022,R023,R333	
8	CHIP RES, 1/10W, 240 OHM J	1608	3	RX08,RX09,RX10	
9	CHIP RES, 1/10W, 270 OHM J	1608	3	R323,R324,R325	
10	CHIP RES, 1/10W, 300 OHM J	1608	1	R338	
11	CHIP RES, 1/10W, 330 OHM J	1608	2	R260,R261	
12	CHIP RES, 1/10W, 470 OHM J	1608	10	R215,R216,R217,R218,R219,R220,R221,R222,R329,C602	
13	CHIP RES, 1/10W, 510 OHM J	1608	1	R337	
14	CHIP RES, 1/10W, 680 OHM J	1608	3	R327,R376,R377	
15	CHIP RES, 1/10W, 1K OHM J	1608	22	R001,R013,R014,R018,R019,R025,R202,R307,R317,R318,R340,R369,R371,R615,R617,R618,RX05,RX06,RX07,RX14,RX15	
16	CHIP RES, 1/10W, 1.3K OHM J	1608	1	R015	

NO	Spec	Pak'	Usa'	Location No	etc
17	CHIP RES, 1/10W, 2.7K OHM J	1608	2	R002,R003	
18	CHIP RES, 1/10W, 3.3K OHM J	1608	5	R373,RS05,RS10,RS11,RS12	
19	CHIP RES, 1/10W, 4.7K OHM J	1608	17	RX03,RX04,R020,R021,R024,R208,R251,R252,R255,R256,R322,R332,R342,R380,R383,R613,R619	
20	CHIP RES, 1/10W, 10K OHM J	1608	6	R004,R007,R205,R258,R801,R906	
21	CHIP RES, 1/10W, 15K OHM J	1608	2	R006,R301	
22	CHIP RES, 1/10W, 22K OHM J	1608	5	R009,R259,R308,R802,R907	
23	CHIP RES, 1/10W, 24K OHM J	1608	2	RX16,R254	
24	CHIP RES, 1/10W, 33K OHM J	1608	1	R336	
25	CHIP RES, 1/10W, 47K OHM J	1608	9	R010,R011,R012,R204,R206,R207,R211,R214,R328	
26	CHIP RES, 1/10W, 1M OHM J	1608	1	R620	
27	CHIP RES' ARRAY 8P4R- 100 OHM J	1608	19	R362,R365,R367,R370,R372,R374,R602,R603,R604,R605,R607,R608,R609,R610,R701,R702,R703,R704,R705	
28	CHIP CAP' 16V 0.47uF Z	1608	33	CS03,CS04,CS05,CS06CS07,CS08,C204,C209,C211,C213,C215,C225,C230,C231,C232,C233,C238,C239,C242,C243,C306,C311,C313,C316,C319,C321,C333,C335	
				C342,C394,C395,C396,C399	
29	CHIP CAP' 16V 1uF Z	1608	6	C334,C343,C348,C353,C355,C358	
30	CHIP CAP' 25V 0.0015uF Z	1608	5	C303,C326,C329,C338,C350	
31	CHIP CAP' 25V 0.001uF Z	1608	7	C001,C004,C205,C207,C255,C260,CX01	
32	CHIP CAP' 25V 0.0022uF Z	1608	1	C305	
33	CHIP CAP' 25V 0.0039uF Z	1608	1	C384	
34	CHIP CAP' 25V 0.039uF Z	1608	1	C385	
35	CHIP CAP' 25V 0.047uF Z	1608	7	C308,C314,C324,C331,C379,C380,C382	
36	CHIP CAP' 25V 0.068uF Z	1608	3	C309,C317,C322	
37	CHIP CAP' 25V 0.1uF Z	1608	82	CS01,C002,CX04,CX06,C006,CX09,C009,CX10,CX11,CX12,C202,C219,C224,C227,C229,C251,C257,C261,C336,C357,C361,C362,C365,C366,C367,C368,C370	
				C371,C373,C374,C375,C376,C377,C386,C387,C390,C398,C603,C604,C605,C606,C607,C608,C609,C610,C611,C613,C614,C617,C619,C620,C622,C624,C625	
				C626,C627,C702,C703,C704,C705,C706,C707,C709,C710,C711,C712,C713,C714,C802,C804,C805,C808,C810,C812,C814,C816,C818,C820,C904,C905,C918,C921	
38	CHIP CAP' 25V 0.22uF Z	1608	4	C302,C328,C339,C349	
39	CHIP CAP' 25V 100pF J	1608	8	C203,C206,C220,C223,C312,C318,C320,C397	
40	CHIP CAP' 25V 10pF J	1608	3	C378,C381,C383	
41	CHIP CAP' 25V 22pF J	1608	2	C623,C628	
42	CHIP CAP' 25V 270pF J	1608	6	C345,C346,C347,C392A,C392,C393	
43	CHIP CAP' 25V 330pF J	1608	10	C234,C235,C236,C237,C240,C241,C244,C245,C389,C391	
44	CHIP CAP' 25V 33pF J	1608	2	C007,C008	
45	CHIP CAP' 25V 390pF J	1608	4	C304,C330,C337,C351	
46	CHIP CAP' 25V 47pF J	1608	1	CX08	
47	CHIP CAP' 25V 56pF J	1608	5	C212,C214,C216,CX02,CX03	
48	CHIP CAP' 25V 6pF J	1608	4	C208,C210,C307,C310	
49	CHIP COIL 10uH	2012	17	L001,L201,L206,L207,L301,L311,L312,L314,L317,L360,L361,L362,L601,L602,L603,LX01,LX02	
50	CHIP COIL 2.2uH	2012	10	L303,L305,L306,L308,L313,L315,L316,L323,L324,L325,	
51	CHIP COIL CHOKE, 47uH	SMD	1	L804	
52	CHIP DIODE, DAN217	SOT-23	2	D360,D361	
53	CHIP DIODE, MBR5340	SMC	1	D801	
54	CHIP EMI FILTER, EF-1T2012-330JT	2012	37	LS01,LS02,LS03,LS04,LS05,L202,L203,L204,L205,L208,L209,L210,L211,L212,L213,L214,L215,L252,L253,L302,L304,L307,L309,L310,L318,L319,L320,L321,L322	
				L363,L364,L365,L366,L367,L368,L369,L370	
55	CHIP TR, BC848B	SOT-23	13	Q001,Q002,Q251,Q301,Q302,Q304,Q305,Q801,Q901,QS01,QS02,QS03,QS04	
56	CHIP TR, BC858B	SOT-23	1	Q303	
57	SMD WAFER, GF056-50S-LSS-P2000 / 50Pin	SMD	1	CN92M	
58	IC LOGIC, 74F14FC	SOIC	1	IC362	
59	IC ADC, AD9883A	MQFP-128	1	IC360	
60	FET, FDS4435C	SOP-J8	2	IC802,IC903	
61	REGULATOR, KIA7808AF	D'PACK	1	IC805	
62	REGULATOR, KIA78DL05F	D'PACK	1	IC801	
63	REGULATOR, LD1117DT33	D'PACK	1	IC361	
64	DC-DC CONVERTOR, SI-8050SD	TO-263	1	IC803	
65	REGULATOR, RC1587M33	TO-263	1	IC804	
66	IC AUDIO, MSP3410G-B8	PQFP-80	1	IC201	
67	IC IMAGE SCALLER, MX88L284AEC	QFP-282	1	IC601	
68	IC VIDEO, VPC3230D-B3	PQFP-80	1	IC301	
69	CHIP X-TAL, 12MHz / 33pF	SMD	2	XX01,X001	

NO	Spec	Pak'	Usa'	Location No	etc
70	CHIP X-TAL, 14.31818MHz / 30pF	SMD	1	X601	
71	CHIP X-TAL, 18.432MHz / 15pF	SMD	1	X201	
72	CHIP X-TAL, 20.25MHz / 15pF	SMD	1	X301	
73	IC RESET, KIA7042	SOT-89	1	IC003	
74	IC MEMORY, HY57V161610	SOP-50	2	IC701,IC702	
75	PCB MAIN, P201AM-01	FR-4/LAYER	1		
PCB ASS'Y, MAIN TVL_201M (RAD)					
76	ELEC' CAP, 16V 220uF	5mm	4	C809,C811,C813,C815	
77	ELEC' CAP, 16V 22uF	5mm	4	C919,C920,CX05,CX07	
78	ELEC' CAP, 16V 47uF	5mm	7	C301,C315,C325,C327,C340,C803,C817	
79	ELEC' CAP, 25V 22uF	5mm	2	C903,C906	
80	ELEC' CAP, 25V 47uF	5mm	1	C819	
81	ELEC' CAP, 25V 220uF	5mm	7	C252,C254,C256,C259,C801,C806,C807	
82	ELEC' CAP, 50V 10uF	5mm	27	CS02,C003,C005,C010,C201,C217,C218,C221,C222,C226,C228,C262,C332,C356,C359,C360,C363,C364,C369,C372,C601,C612,C616,C618,C621,C701,C709	
83	ELEC' CAP, 50V 1uF	5mm	2	C253,C258	
PCB ASS'Y, MAIN TVL_201M (AXI)					
84	BEAD CORE, 3X5	3X5	5	L251,L801,L802,L803,L901	
85	FUSE, R251 010		1	F801	
PCB ASS'Y, MAIN TVL_201M (M/T)					
86	IC VIDEO S/W, TEA6425	DIP	1	IC302	
87	IC RGB S/W, TEA5114A	DIP	1	IC51	
88	IC MICOM, S3P863AXZZ / OTP	DIP	1	IC001	
89	IC EEPROM, 24C16	DIP	1	IC002	
90	IC TTX, SAA5264	DIP	1	ICX1	
91	IC EEPROM, 24C02	DIP	1	ICX2	
92	IC AUDIO AMP, TDA1519B	SOT110	1	IC251	
93	WAFER, 53014-0310 / 3Pin Straight	53014-0310	1	CN03M	
94	WAFER, 53014-0410 / 4Pin Straight	53014-0410	1	CN25M	
95	WAFER, 53014-0510 / 5Pin Straight	53014-0510	1	CN01M	
96	WAFER, 53014-0610 / 6Pin Straight	53014-0610	1	CN91M	
97	HARNESS, Tuner / 10Pin 300mm		1	CN21M	
98	JACK PIN, PJ6054T(SHIELD)		2	JA202,JA302	
99	JACK PIN, PJ6054T-01(SHIELD)		1	JA303	
100	JACK PHONE, PPJ35G		1	JA203	
101	JACK PIN-BLOCK, PMJ014T(SHIELD)		1	JA301B	
102	JACK D-SUB, PDC013		1	JA013	
103	JACK DC, PDJ005		1	JA801	
104	JACK SCART, PMJ002		1	JAS1	
105	IC SOCKET, WSDIF-42T-1.778		1	IC001	
PCB ASS'Y, TUNER TVL_201M (RAD)					
1	ELEC' CAP, 16V 100uF	5mm	1	CT01	
PCB ASS'Y, TUNER TVL_201M (AXI)					
2	RES' CARBON, 1/6W 100 OHM J		2	RT01,RT02	
3	COIL, 10uH / AL03		1	LT01	
4	CERAMIC CAP, 0.1uF	CA2644	1	CT02	
5	PCB TUNER, P151AT-01	FR-1	1		
PCB ASS'Y, TUNER TVL_201M (M/T)					
6	WAFER, 53014-1010 / 10Pin Straight	53014-1010	1	CN21T	
7	TUNER, TCPQ9091PD27D(S)	SAMSUNG	1	TU01	
PCB ASS'Y, LED TVL_201M (AXI)					

NO	Spec	Pak'	Usa'	Location No	etc
1	CERAMIC CAP, 0.1uF J	CA2644	1	CC03	
2	RES' CARBON, 1/6W 47 OHM J	AXIAL	1	RC01	
3	RES' CARBON, 1/6W 47K OHM J	AXIAL	1	RC02	
4	RES' CARBON, 1/6W 680 OHM J	AXIAL	2	RC08, RC09	
PCB ASS'Y, LED TVL_201M (M/I)					
5	HARNESS, LED / 5Pin 500mm	500mm	1	CN01C	
6	LED DUAL, SAMS270		1	DL01	
7	REMOCON RECIEVER, FRP-3051		1	RM01	
PCB ASS'Y, SW TVL_201M (AXI)					
1	RES' CARBON, 1/6W 390 OHM J	AXIAL	2	RC06,RC07	
2	RES' CARBON, 1/6W 620 OHM J	AXIAL	1	RC05	
3	RES' CARBON, 1/6W 1.3K OHM J	AXIAL	1	RC04	
4	RES' CARBON, 1/6W 2.2K OHM J	AXIAL	1	RC03	
5	SW TACT, HST-0260A	5mm	7	SW01,SW02,SW03,SW04,SW05,SW06,SW07	
6	PCB S/W, P151AS-01	FR-1	1		
PCB ASS'Y, SW TVL_201M (M/I)					
7	HARNESS, SW / 3Pin 100mm	2mm	1	CN03C	
PCB ASS'Y, SPK TVL_201M (M/I)					
1	PCB SPEAKER , P201SPK-2	FR-1	1		
2	HARNESS, SPK / 2Pin_3Wire		2	SPK1	
3	PPJ35D (SPEAKER SOCKET)		2	JAS1	
PCB ASS'Y, ST COVER TVL_201M (M/I)					
4	HARNESS, SPK / 4Pin_220mm		1	SPK2	
5	PPJ35D (SPEAKER SOCKET)		2	JAS2,JAS3	

9. Main Printed Circuit Board

1) Top Side Pattern

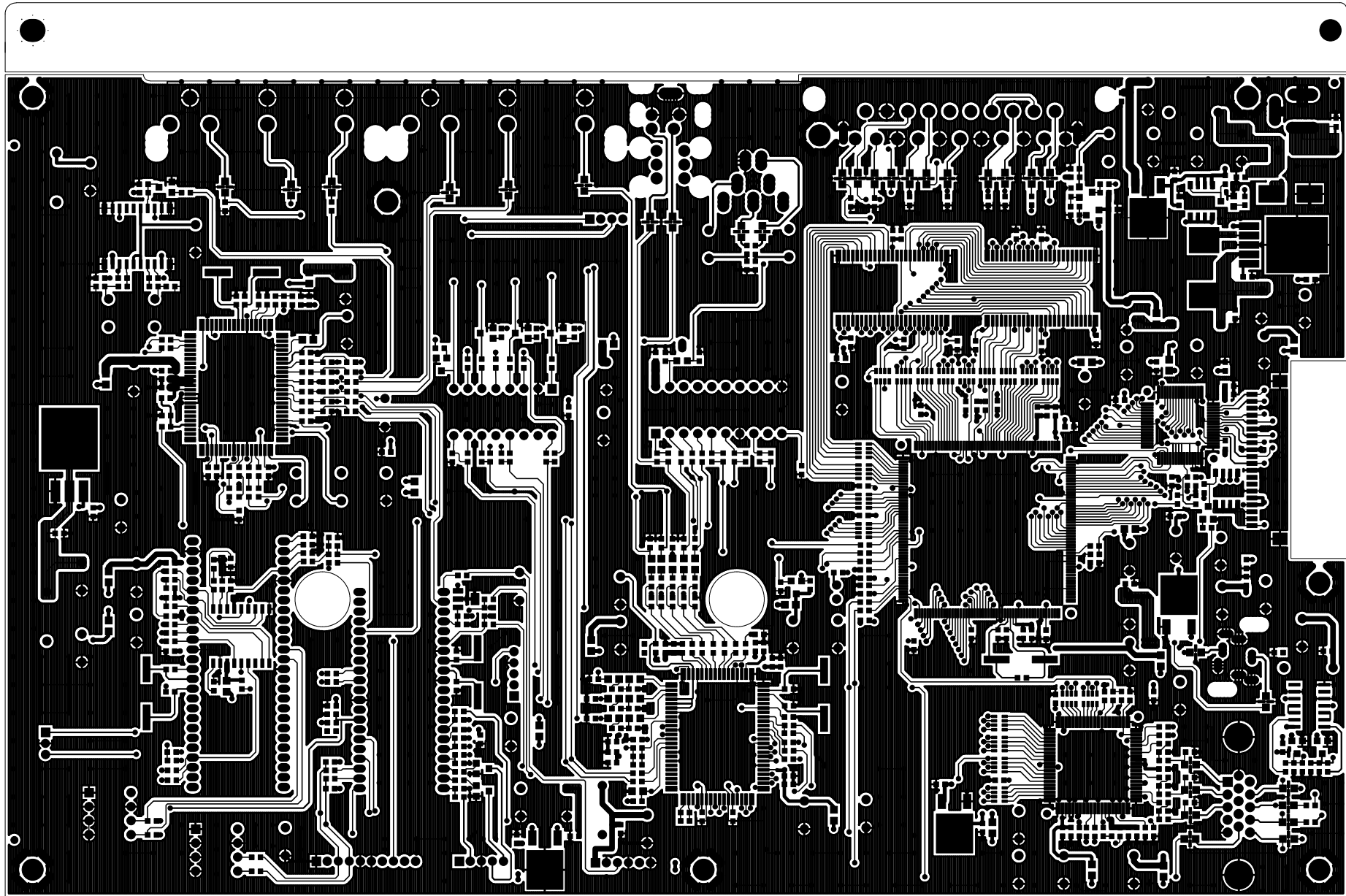

2) Bottom Side Pattern

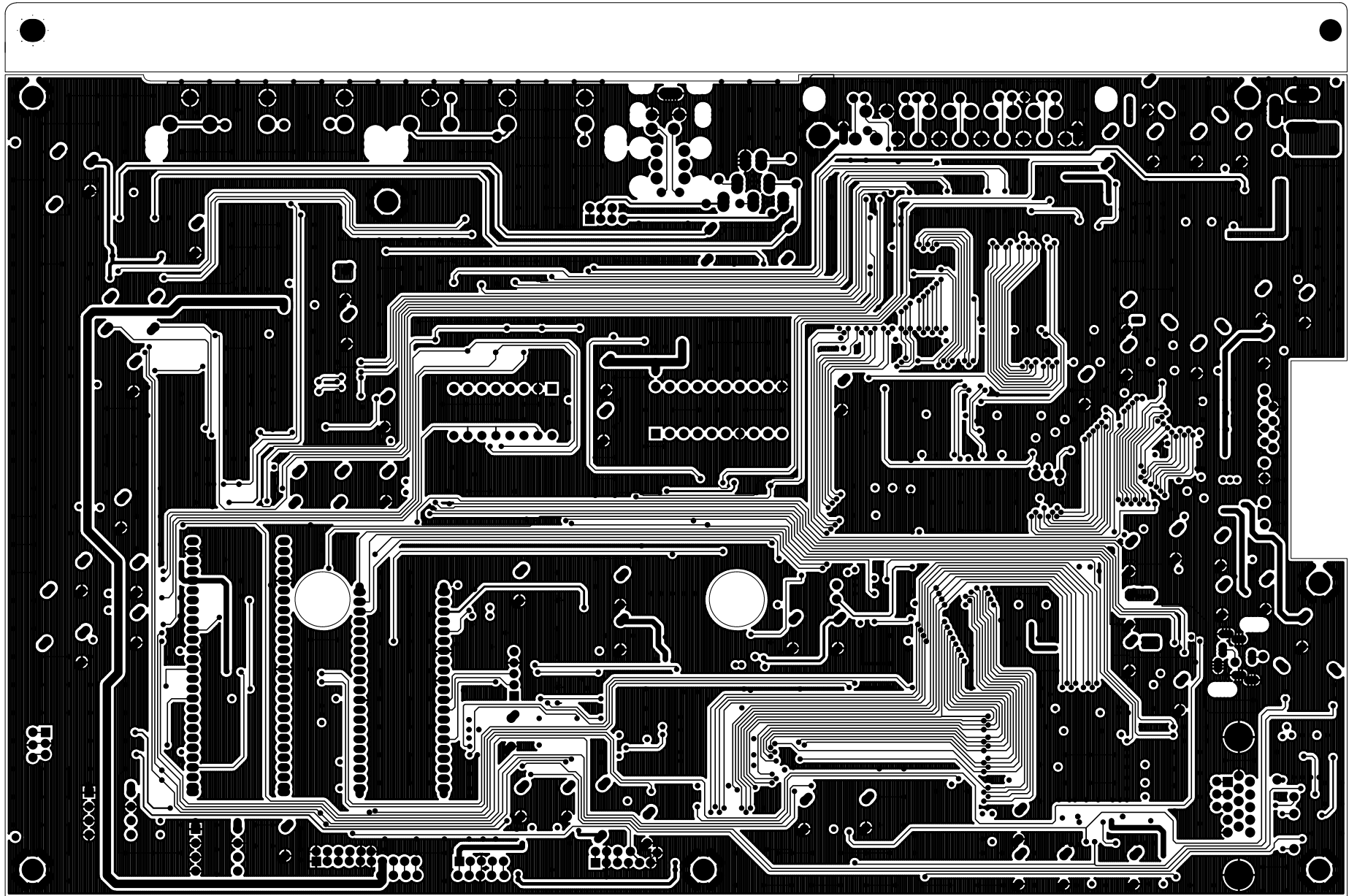

3) VCC Layer

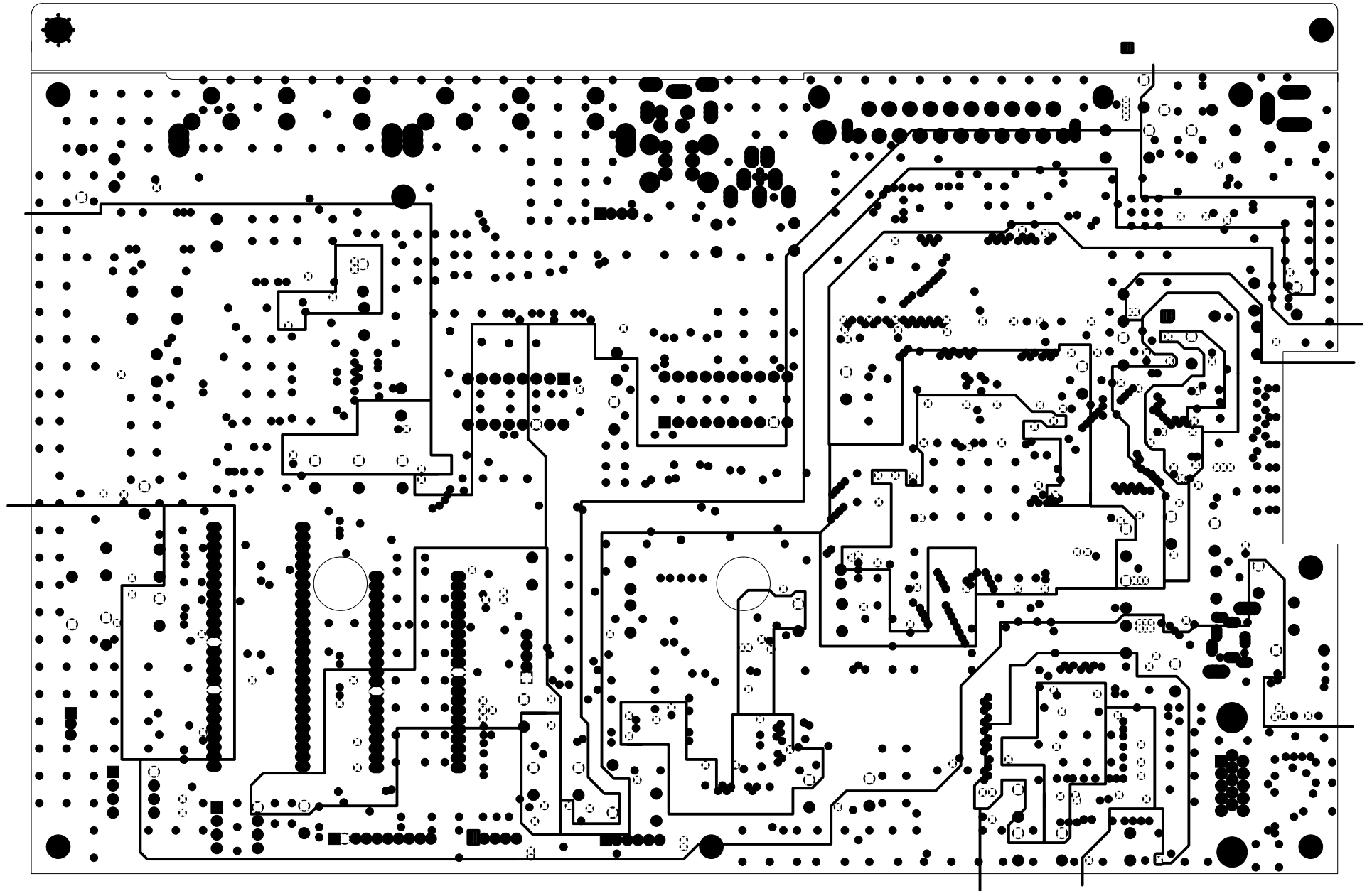

4) Ground Layer

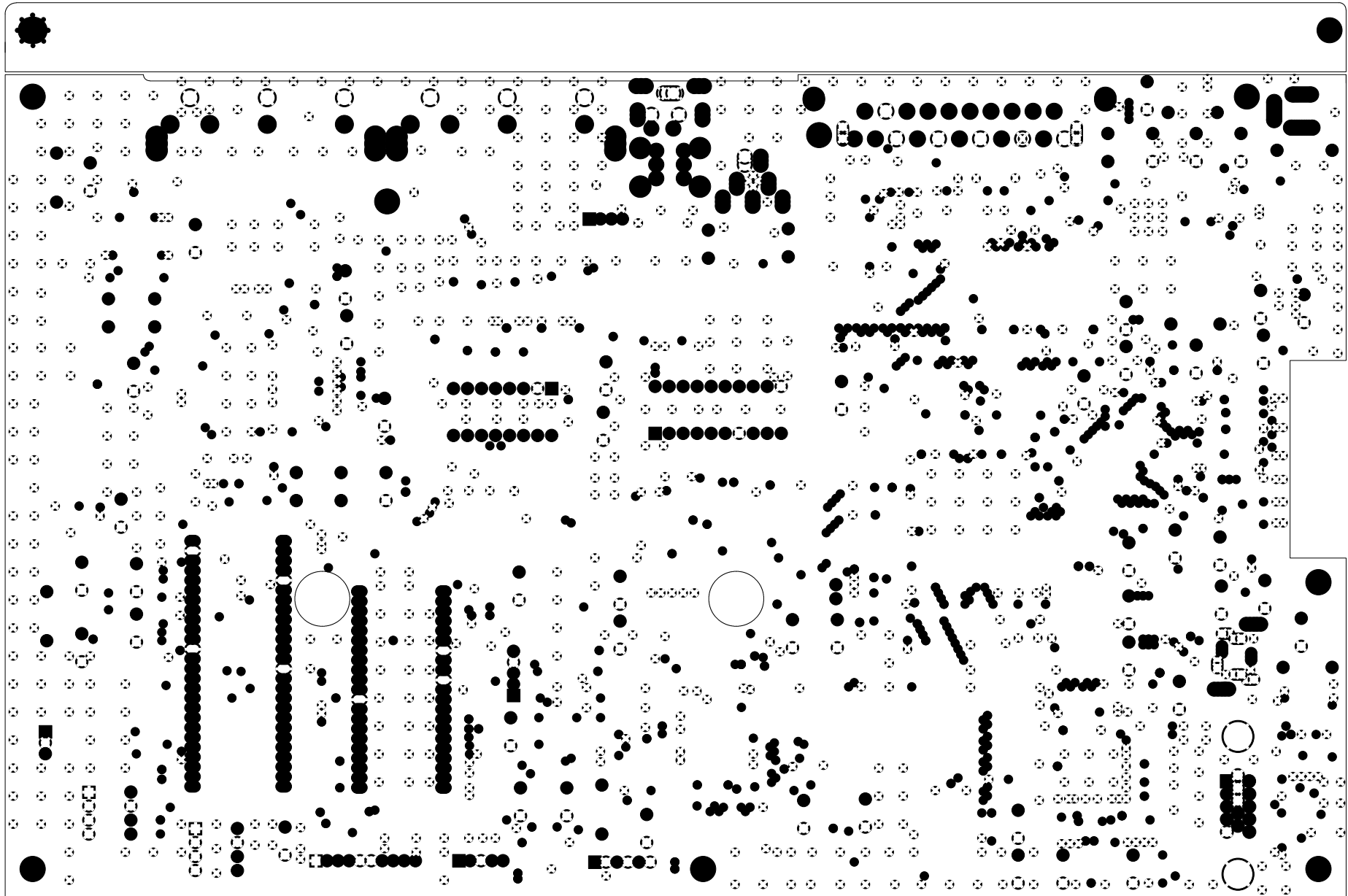

5) Top Side Solder

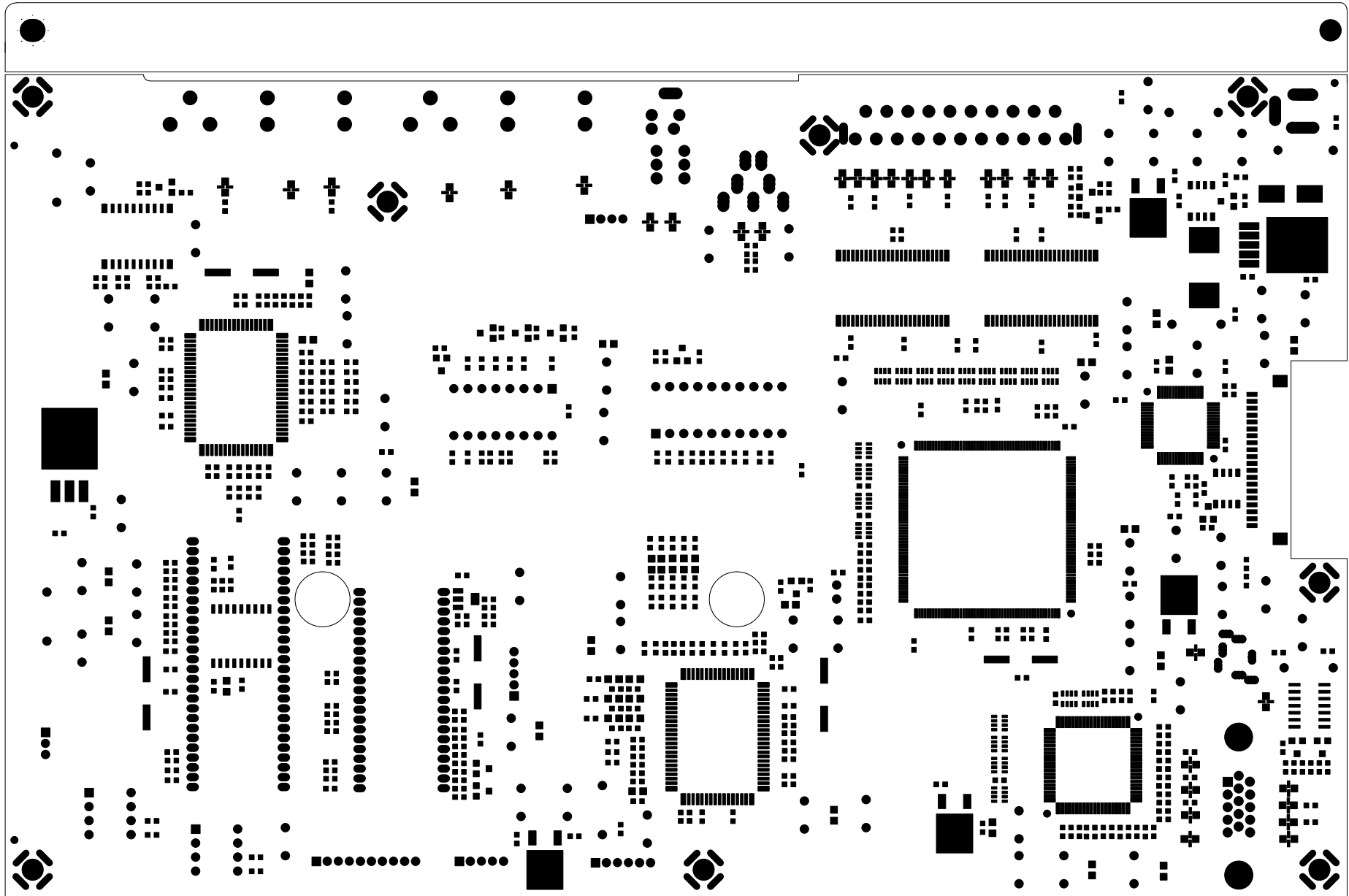

6) Bottom Side Solder

