

COLOR TELEVISION

SERVICE MANUAL

MODEL NO.: PF21GB300

CHASSIS NO.: ETE-2

Please read this manual carefully before service!

Catalog

Safety Instructions and Maintenance.....	2
Adjustments.....	5
Structure and Chassis Function Description	13
Service Data	15

1. SAFETY INSTRUCTIONS AND MAINTENANCE

WARNING: BEFORE SERVICING THIS CHASSIS, READ THE "X-RAY RADIATION PRECAUTION", "SAFETY PRECAUTION" AND "PRODUCT SAFETY NOTICE" INSTRUCTION BELOW.

1.1 X-RAY RADIATION PRECAUTION

1.1.1 The EHT must be checked every time the TV is serviced to ensure that the CRT does not emit X-ray radiation as result of excessive EHT voltage. The maximum EHT voltage permissible in any operating circumstances must not exceed the rated value. When checking the EHT, use the High Voltage Check procedure in this manual using an accurate EHT voltmeter.

1.1.2 The only source of X-RAY radiation in this TV is the CRT. The TV minimizes X-RAY radiation, which ensures safety during normal operation. To prevent X-ray radiation, the replacement CRT must be identical to the original fitted as specified in the parts list.

1.1.3 Some components used in this TV have safety related characteristics preventing the CRT from emitting X-ray radiation. For continued safety, replacement component should be made after referring the PRODUCT SAFETY NOTICE below.

1.1.4 Service and adjustment of the TV may result in changes in the nominal EHT voltage of the CRT anode. So ensure that the maximum EHT voltage does not exceed the rated value after service and adjustment.

1.2 SAFETY PRECAUTION

WARNING: REFER SERVICING TO QUALIFIED SERVICE PERSONNEL ONLY.

1.2.1 The TV has a nominal working EHT voltage. Extreme caution should be exercised when working on the TV with the back removed.

Do not attempt to service this TV if you are not conversant with the precautions and procedures for working on high voltage equipment.

When handling or working on the CRT, always discharge the anode to the TV chassis before removing the anode cap in case of electric shock.

The CRT, if broken, will violently expel glass fragments. Use shatterproof goggles and take extreme care while handling.

Do not hold the CRT by the neck as this is a very dangerous practice..

1.2.2 It is essential that to maintain the safety of the customer all power cord forms be replaced exactly as supplied from factory.

1.2.3 Voltage exists between the hot and cold ground when the TV is in operation. Install a suitable isolating transformer of beyond rated overall power when servicing or connecting any test equipment for the sake of safety.

1.2.4 When replacing ICs, use specific tools or a static-proof electric iron with small power (below 3 5W).

1.2.5 Do not use a magnetized screwdriver when tightening or loosening the deflection yoke assembly to avoid electronic gun magnetized and decrement in convergence of the CRT.

1.2.6 When remounting the TV chassis, ensure that all guard devices, such as nonmetal control buttons, switch, insulating sleeve, shielding cover, isolating resistors and capacitors, are installed on the original place.

1.2.7 Replace blown fuses within the TV with the fuse specified in the parts list.

1.2.8 When replacing wires or components to terminals or tags, wind the leads around the terminal before soldering. When replacing safety components identified by the international hazard symbols on the circuit diagram and parts list, it must be the company-approved type and must be mounted as the original.

1.2.9 Keep wires away from high temperature components.

1.3 PRODUCT SAFETY NOTICE

CAUTION: FOR YOUR PROTECTION, THE FOLLOWING PRODUCT SAFETY NOTICE

SHOULD BE READ CAREFULLY BEFORE OPERATING AND SERVICING THIS TV SET.

1.3.1 Many electrical and mechanical components in this chassis have special safety-related characteristics. These characteristics are often passed unnoticed by a visual inspection and the X-ray radiation protection afforded by them cannot necessarily be obtained by using replacements rated at higher voltages or wattage, etc. Components which have these special safety characteristics in this manual and its supplements are identified by the international hazard symbols on the circuit diagram and parts list. Before replacing any of these components read the parts list in this manual carefully. Substitute replacement components which do not have the same safety characteristics as specified in the parts list may create X-ray radiation.

1.3.2 Do not slap or beat the cabinet or CRT, since this may result in fire or explosion.

1.3.3 Never allow the TV sharing a plug or socket with other large-power equipment. Doing so may result in too large load, causing fire.

1.3.4 Do not allow anything to rest on or roll over the power cord. Protect the power cord from being walked on, modified, cut or pinched, particularly at plugs.

1.3.5 Do not place any objects, especially heavy objects and lightings, on top of the TV set. Do not install the TV near any heat sources such as radiators, heat registers, stove, or other apparatus that produce heat.

1.3.6 Service personnel should observe the SAFETY INSTRUCTIONS in this manual during use and servicing of this TV set. Otherwise, the resulted damage is not protected by the manufacturer.

1.4 SAFETY SYMBOL DESCRIPTION



The lightning symbol in the triangle tells you that the voltage inside this product may be strong enough to cause an electric shock. Extreme caution should be exercised when working on the TV with the back removed.



This is an international hazard symbol, telling you that the components identified by the symbol have special safety-related characteristics.

UL This symbol tells you that the critical components identified by the UL marking have special safety-related characteristics.

VDE or TUV This symbol tells you that the critical components identified by the VDE/TUV marking have special safety-related characteristics.

1.5 MAINTENANCE

1.5.1 Place the TV set on a stable stand or base that is of adequate size and strength to prevent it from being accidentally tipped over, pushed off, or pulled off. Do not place the set near or over a radiator or heat register,

or where it is exposed to direct sunlight.

1.5.2 Do not install the TV set in a place exposed to rain, water, excessive dust, mechanical vibrations or impacts.

1.5.3 Allow enough space (at least 10cm) between the TV and wall or enclosures for proper ventilation.

1.5.4 Slots and openings in the cabinet should never be blocked by clothes or other objects.

1.5.5 Please power off the TV set and disconnect it from the wall immediately if any abnormal condition are met, such as bad smell, belching smoke, sparkling, abnormal sound, no picture/sound/raster. Hold the plug firmly when disconnecting the power cord.

1.5.6 Unplug the TV set from the wall outlet before cleaning or polishing it. Use a dry soft cloth for cleaning the exterior of the TV set or CRT screen. Do not use liquid cleaners or aerosol cleaners.

2. ADJUSTMENTS

2.1 SET-UP ADJUSTMENTS

The following adjustments should be made when a complete realignment is required or a new picture tube is installed.

Perform the adjustments in the following order:

Color purity

Convergence

White balance

Notes:

The purity/convergence magnet assembly and rubber wedges need mechanical positioning.

For some picture tubes, purity/ convergence adjustments are not required.

2.1.1 Color Purity Adjustment

Preparation:

Before starting this adjustment, adjust the vertical sync, horizontal sync, vertical amplitude and focus.

- Face the TV set north or south.
- Connect the power plug into the wall outlet and turn on the main power switch of the TV set. •Operate the TV for at least 15 minutes.
- Degauss the TV set using a specific degaussing coil.
- Set the brightness and contrast to maximum.
- Counter clockwise rotate the R /B low brightness potentiometers to the end and rotate the green low brightness potentiometer to center.
- Receive green raster pattern signals.
- Loosen the clamp screw holding the deflection yoke assembly and slide it forward or backward to display a vertical green zone on the screen. Rotate and spread the tabs of the purity magnet around the neck of the CRT until the green zone is located vertically at the center of the screen. •Slowly move the deflection yoke assembly forward or backward until a uniform green screen is obtained.
- Tighten the clamp screw of the assembly temporarily. Check purity of the red raster and blue raster until purities of the three rasters meet the requirement.

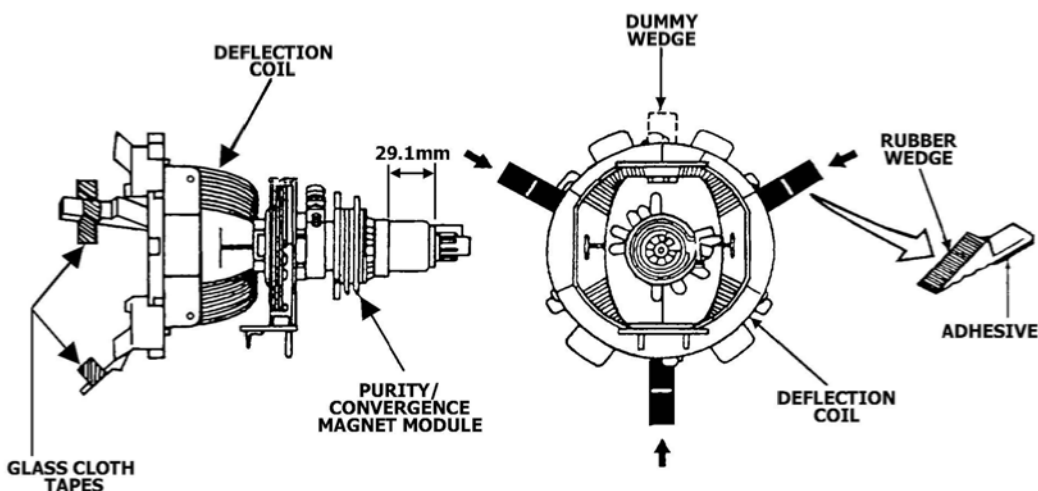

2.1.2 Convergence Adjustment

Preparation: Before attempting any convergence adjustment, the TV should be operated for at least 15 minutes.

- Center convergence adjustment.
- Receive dot pattern.
- Adjust the brightness/contrast controls to obtain a sharp picture.
- Adjust two tabs of the 4-pole magnet to change the angle between them and red and blue vertical lines are superimposed each other on the center of the screen.
- Turn both tabs at the same time keeping the angle constant to superimpose red and blue horizontal on the center of the screen.
- Adjust two tabs of the 6-pole magnet to superimpose red/blue line and green line.
- Remember red and blue movement. Repeat steps 2.1.3 2. 1.5 until optimal convergence is obtained.
- Circumference convergence adjustment.
- Loosen the clamp screw holding the deflection yoke assembly and allow it tilting.
- Temporarily put the first wedge between the picture tube and deflection yoke assembly. Move front of the deflection yoke up or down to obtain better convergence in circumference. Push the mounted wedge in to fix the yoke temporarily.
- Put the second wedge into bottom.
- Move front of the deflection yoke to the left or right to obtain better convergence in circumference.
- Fix the deflection yoke position and put the third wedge in either upper space. Fasten the deflection yoke assembly on the picture tube.
- Detach the temporarily mounted wedge and put it in either upper space. Fasten the deflection yoke assembly on the picture tube.
- After fastening the three wedges, recheck overall convergence and ensure to get optimal convergence. Tighten the lamp screw holding the deflection yoke assembly.

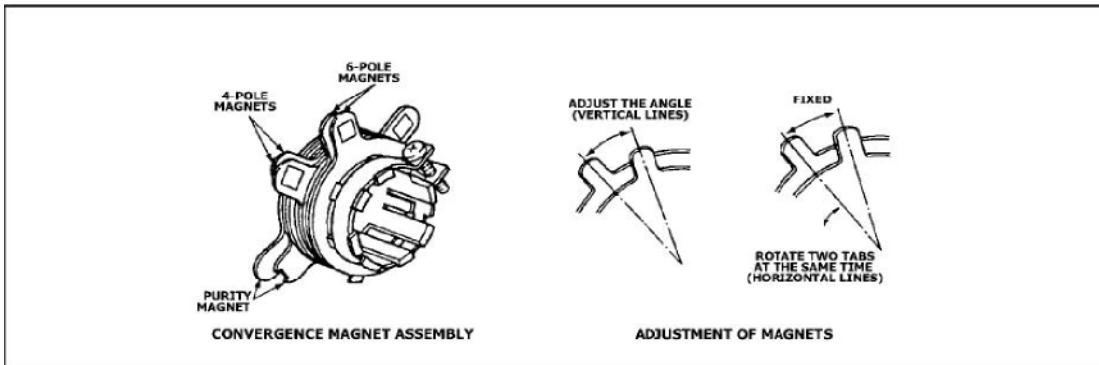

Fig. 2

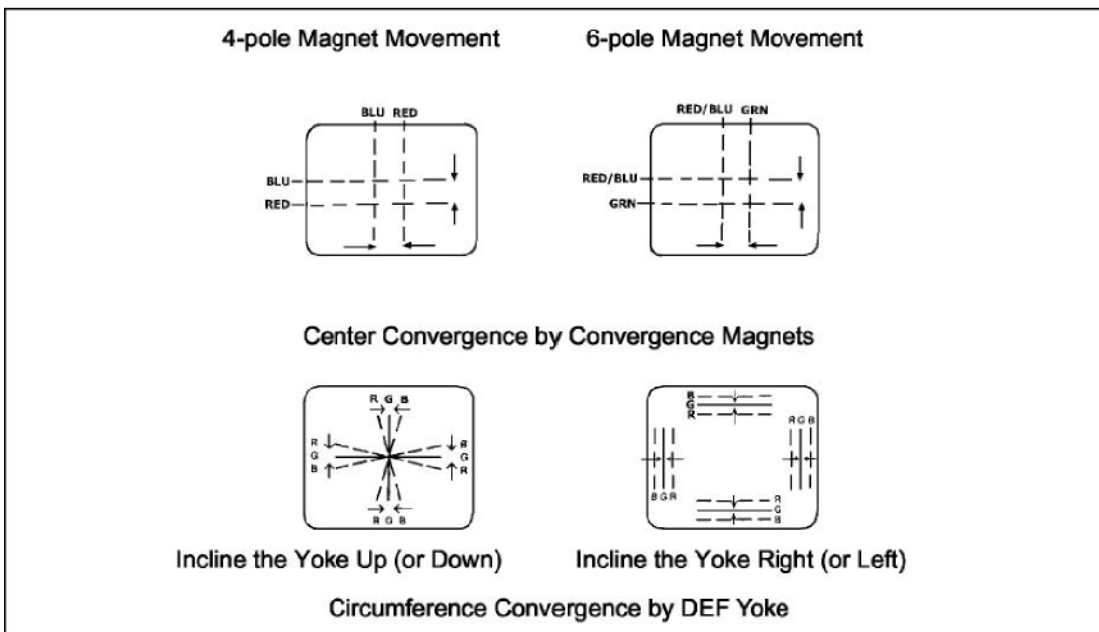

Fig.3

2.1.3 White Balance Adjustment

Generally, white balance adjustment is made with professional equipment. It's not practical to get good white balance only through manual adjustment. For TVs with I2C bus control, change the bus data to adjust white balance.

2.2 CIRCUIT ADJUSTMENTS

Preparation:

Circuit adjustments should be made only after completion of set-up adjustments.

Circuit adjustments can be performed using the adjustable components inside the TV set. For TVs with 2 I C bus control, first change the bus data.

2.2.1 Degaussing

A degaussing coil is built inside the TV set. Each time the TV is powered on, the degaussing coil will automatically degauss the TV. If the TV is magnetized by external strong magnetic field, causing color spot on the screen, use a specific degausser to demagnetize the TV in the following ways. Otherwise, color distortion will be shown on the screen.

- Power on the TV set and operate it for at least 15 minutes.
- Receive red full-field pattern.

- Power on the specific degausser and face it to the TV screen.
- Turn on the degausser. Slowly move it around the screen and slowly take it away from the TV.
- Repeat the above steps until the TV is degaussed completely.

2.2.2 Confirmation and Adjustment for Voltage

Caution: +B voltage has close relation to high voltage. To prevent X-ray radiation, set +B voltage to the rated value. The maximal radiator is not GND by reason of linking to TP--12V.

- Make sure that the supply voltage is within the range of the rated value.
- Connect a digital voltmeter to the voltage output terminal of the main PCB. Power on the TV and set the brightness and sub-brightness to minimum. Ensure that the voltage from the main PCB reads as follows.
- Regulate voltage adjustment components on the power section until the +B the voltage reaches the rated value.

Test Point	Voltage	Test Point	Voltage
TP-115V	117V±1.5V	TP-18V	23V±2V
TP-15V	15.5V±1V	TP-5V	5V±0.5V
TP-3.3V	3.3V±0.3V	TP-8V	8V±1V
TP-12V	13V±2V	TP--12V	-13V±2V
TP-195V	196V±2V		

Note: It's impossible to check the power part separately from the main chassis board as the part is mounted on the main chassis board. The power components, etc. should be checked for burnout when power-on. If burned out, do not power on the TV again until the cause is found out.

2.2.3 High Voltage Inspection

Measure voltages of test points on the main PCB with the digital voltmeter. Measure the CRT high voltage with the high-voltage testing equipment and heater voltage with the high-frequency effective voltmeter. The rated values are shown as below.

Test Point	Voltage	Test Point	Voltage
Negative of VD49 1	1 96±2V	14"GS_CRT_anode	22±1.5KV
21 "FS_CRT_anode	26±1.5KV	21 "PF-CRT-anode	27±1.5KV
Heater	6.3±0.3Vrms		

2.2.4 Focus Adjustment

Caution: Dangerously high voltages are present inside the TV. Extreme caution should be exercised when working on the TV with the back removed.

- After removing the back cover, look for the FBT on the main PCB. There should be a FCB (FOCUS) on the FBT.
- Power on the TV and preheat it for 15 min.
- Receive a normal TV signal. Rotate knob of the FCB until you get a sharp picture.

2.25 SERVICE mode

To enter the SERVICE mode

Set the volume to 0. Then press and hold the MUTE button on the remote control, and press the MENU button on the TV to enter the SERVICE mode. To exit from the SERVICE mode, turn off the TV set by the POWER button on the remote control.

Caution: The user service mode adjustment can be changed only when service personnel adjust the whole set

data during servicing. As the control data have dramatic effects on functions and performance of the TV, service personnel should not tell user how to enter the SERVICE mode to avoid improper data settings.

Adjustments and bus data

SERVICE mode	Adjust	Description	Note
STS0/1/2/3/4		UOC system surveillance display	
IFP1	00	IF PRESET VALUE 1	#
IFP2	00	IF PRESET VALUE2	#
TINT	20	BASE BAND TINT CONTROL	#
5WBF	adjustable		
5WBR	adjustable		
TWBK	88	TIME OF "WIDE BLANKING"	#
PWL	15	Peak white limited	#
OIF	20	Off-set if demodulatour	#
6WBF	adjustable		
6WBR	adjustable		
5HP/6HP	adjustable	HOR PARALLELOGRAM CORRECTION	*
5HB/6HB	adjustable	HOR BOW CORRECTION	*
5HSH/6HSH	adjustable	HORIZONTAL SHIFT	*
5HZD/6HZD	0A	DVD HORIZONTAL SHIFT	***
5EWW/6EWW	adjustable	E-W WIDTH	*
5EWP/6EWP	adjustable	E-W PARABOLA WIDTH	*
5UCR/6UCR	adjustable	E-W UPPER CORNER PARABOLA	*
5LCR/6LCR	adjustable	E-W BOTTOM CORNER PARABOLA	*
5TC/6TC	adjustable	E-W TRAPEZIUM	*
5VSL/6VSL	adjustable	VERTICAL SLOPE	*
5VAM/6VAM	adjustable	VERTICAL AMPLITUDE	*
5SCL/6SCL	adjustable	VERTICAL S CORRECTION	*
5VSH/6VSH	adjustable	VERTICAL SHIFT	*
5VZD/6VZD	00	DVD VERTICAL SHIFT	***
5VOF/6VOF	26	OSDVERTICAL SHIFT	**
RED	20	BLACK LEVEL OFFSET:R	**
GRN	20	BLACK LEVEL OFFSET:G	**
WPR	1F	WHITE POINT R	**
WPG	1F	WHITE POINT G	**
WPB	1F	WHITE POINT B	**
DRED	00	DVD BLACK LEVEL OFFSET:R	**
DGRN	50	DVD BLACK LEVEL OFFSET:R	**
DWPR	00	DVD WHITE POINT R	**
DWPG	00	DVD WHITE POINT G	**
DWPB	00	DVD WHITE POINT B	**
YDFP/YDFN/ YDFB/YDFG	07	LUMINANCE DELAY TIME	#
TOP	adjustable	AGC TAKE OVER	*

VOL	2A	Volume control	* * *
VOLA	20	Dummy AVL level	#
CORE	03	Core noise reduction	#
VLG 1	0A	The first line vertical position of LOGO	* *
VLG2	0E	The second line vertical position of LOGO	* *
COL1	04	The color of first line LOGO	**
COL2	04	The color of second line LOGO	* *
TIME	0F	The time of No signal auto off	#
IFFS	02	IF 38MHZ(03)/38.9MHZ(02)/45.75MHZ(01)	
HDOL	0A	Cathode drive level	
AGC	03	AGC time	#
VG2B	1A	VG2 bright set	***
SBRI	24	Sub bright	***
MBRI	30	Max bright	***
SCON	20	Sub contrast	***
MCON	39	Max contrast	***
SCOL	32	Sub color	
OP1		Optional 1	***
OP2		Optional 2	* * *
OP3		Optional 3	***
OP4		Optional 4	* * *
OP5		Optional 5	***
OP6		Optional 6	***
OP7		Optional 7	***
OP8		Optional 8	***
OP9		Optional 9	***
OP10		Optional 10	***
INIT		EEPROM init	
VG2		Screen Voltage : Rotate knob of the SCREEN on the FBT	*
VSD			

	BIT	Name	Decription	Data
OP1	0	OP_HOTEL	HOTEL model, 1:yes;0:no	1
	1	OP_236	CHANNEL number setup(1:236,0:100)	1
	2	OP_NTSC	NTSC (1:yes,0:no)	1
	3	OP_AV2	2 AV input(1:AV2,0:no AV2)	1
	4	OP_S VSH	S-VIDEO input(1:yes;0:no)	0
	5	OP_DVD	DVD input(1:yes,0:no)	0
	6	OP_SCART	SCART(1:yes;0:no)	1
OP2	7	OP_OSO	Switch off in vertical overscan	<u>1</u>
	0	OP_AVL	AVL(1:yes;0:no AVL (SLIM CRT))	1

	1	OP_AUTO_SOUND	AUTO_SOUND	1
	2	OP_NOT_1	Text language setup OP_NOT_3/2/1 ; 1XX-English/ Arabic 011-English /Farsi 010-English /Russian 001-English /Ukrainian 000-English / Paneuro	0
	3	OP_NOT_2		0
	4	OP_NOT_3		0
	5	OP_USER_LOGO		USER'S LOGO SETUP
	6	OP_ON_BLACK	1:blue b a c k ; 0 : b l a c k back	0
	7	OP_FSL		0
OP3	0	OP_ENGLISH	OSD language: 1,ENGLISH	1
	1	OP_CZECH	OSD language: 1, CZECH	1
	2	OP_SLOVAK	OSD language: 1, SLOVAK	1
	3	OP_RUSSIAN	OSD language: 1, RUSSIAN	1
	4	OP_FRENCH	OSD language: 1, FRENCH	1
	5	OP_GERMAN	OSD language: 1, GERMAN	1
	6	OP_ITALY	OSD language: 1, ITALY	1
OP4	7	OP_SPANISH	OSD language: 1, SPANISH	1
	0	OP_PORTUGUESE	OSD language: 1, PORTUGUESE	1
	1	OP_SERBIAN	OSD language: 1, SERBIAN	1
	2	OP_TURKISH	OSD language: 1, TURKISH	1
	3	OP_POLISH	OSD language: 1, POLISH	1
	4	OP_BULGARIAN	OSD language: 1, BULGARIAN	1
	5	OP_ROMANIAN	OSD language: 1, ROMANIAN	1
OP5	6	OP_CROATIAN	OSD language: 1, CROATIAN	1
	7	OP_HUNGARIAN	OSD language: 1, HUNGARIAN	1
	0	OP_UKRAIN	OSD language: 1, Ukrainian	1
	1	OP_ARABIC	OSD language: 1, ARABIC	1
	2	OP_FARSI	OSD language: 1, FARSI	1
	3	OP_BLANK	BLANK	0
	4	OP_BLANK	BLANK	0
OP6	5	OP_RFTOAV	1 : S C A R T 0 : RCA	1
	6	OP_TDA1517	1:TDA1517;0:TFA9842AJ	0
	7	OP_FAKE_AVL	1:FAKE A V L ; 0 : A V L	0
	0	OP_AV_ON	1:AV shutdown,AV r e s t a r t ; 0 : T V restart	1
	1	OP_DIRECT_SWITCH	1:memory-restart;0:power-on and standby	1
	2	OP_HCO	EHT tracking mode	0
	3	OP_CHH_LOGO	1:CHANGHONG l o g o	0
OP6	4	OP_SOUND_DK	1:D/K	1
	5	OP_SOUND_BG	1:B/G	1
	6	OP_SOUND_I	1:I	1
	7	OP_SOUND_M	1:M	1

OP7	0	OP_AUTO_LANGO	AUTO_ Language 4/3/2/1/0: ENGLISH:00000 CZECH:00001 SLOVAK:00010 ...	0
	1	OP_AUTO_LANG 1		0
	2	OP_AUTO_LANG2		0
	3	OP_AUTO_LANG3		0
	4	OP_AUTO_LANG4	0	
	5	OP_FORF	OP_FORF/FORF:	1
	6	OP_FORF	00-AUTO 60HZ,01-KEEP LAST, 10-FORCE 60HZ,11-AUTO 50HZ	1
	7	OP_HOTEL_ON_PROG	1 :Startup on channel 1 hotel model available0	
OP8	0	OP_AUTO_TEST	Power-on self-test , 1 :yes,0,no	0
	1	OP_PSNS	sensibility	0
	2	OP_B SCREEN	Black screen1 Yes;0:No	0
	3	OP_SECAM	1:SECAM	1
	4	OP_DFL	Disable flash protection	1
	5	OP_SIF		0
	6	OP_EXT_SIF0	D/K:00,B/G:01,I:10,M:11.	1
7	OP_EXT_SIF1	0		
OP9	0	OP-TUNER	0:TAF5-E4I22 1:TAF5-C4I21/ TAF5-C4I23	0
	1	OP_TINT	1 :PAL TINT Adjust	1
	2	OP_FMWS	WINDOW OF SOUND PLL:+/-200KHZ	1
	3	OP_FMWS1	WINDOW OF SOUND PLL:+/-600KHZ	0
	4	OP_OSVE		0
	5	OP-FFI		0
	6	OP-SPEED 1	Program quickly, 1:yes,0no	0
	7	OP-SPEED0	Program slowly, 1:yes,0no	0
OP10	0	OP_AKIRA_LOGO	LOGO:AKIRA	0
	1	OP_HBL(only for slim crt)	If HBL=1,5/6WBF and 5/6WBR are available	0
	2	OP_NTSC_TUNER	1:TAF5-U2F22	0
	3	OP_CHILD_LOCK	1 :CHILD LOCK	0
	4	OP_BLANK	BLANK	0
	5	OP_BLANK	BLANK	0
	6	OP_BLANK	BLANK	0
	7	OP_TEXT_KEY	1: (remote-control unit)TEXT key available	1

Notes: The data sheet may differ dependent on different models. The data sheet may differ dependent on different CRTs for the same model.

3. STRUCTURE AND CHASSIS FUNCTION DESCRIPTION

3.1 STRUCTUE BLOCK DIAGRAM

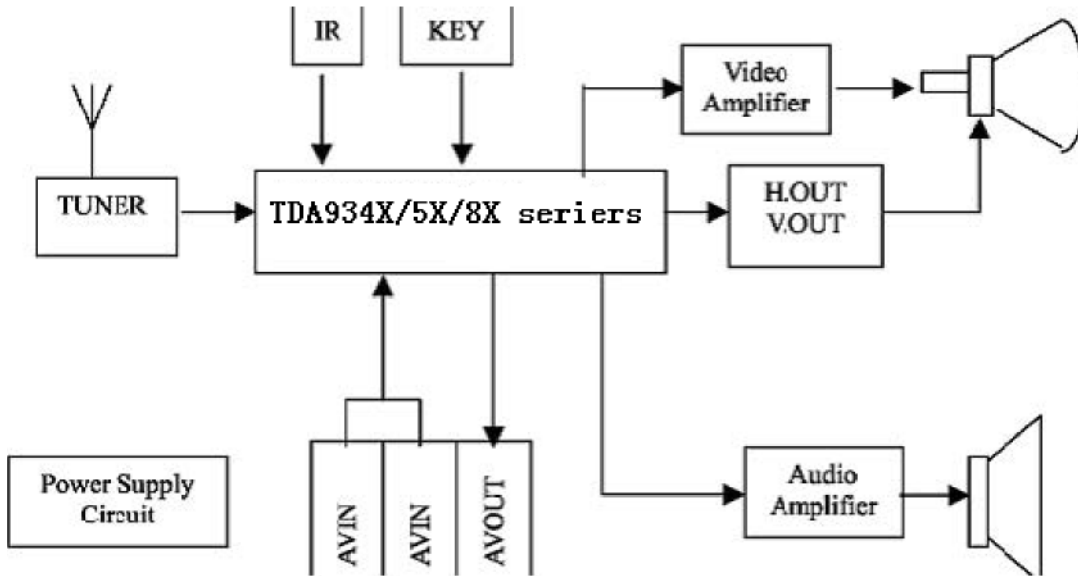

3.2 CHASSIS DESCRIPTION

3.2.1 General Description

ETE-2 chassis is applied in PF21GB300 series. By use of philips UOC for TV small signal processing and bus control, the chassis enables TV tuning, adjustment, control and picture correction, featuring high-integration, high-performance-to-price ratio and high-reliability and compact circuit with fewer external components. The chassis, widely used in small and medium TVs, provides much more convenience for manufacturing and technical service. It includes:

UOC TDA9384PS/N3/3 for PAL/NTSC /SECAM small signal processing and bus control EEPROM AT24C08 for data memory ,TDA4863AJ for vertical output power amplifying, TFA9842AJ for audio power amplifying ,Thick-film IC STR-G5653 for power circuit adjustment and control.

3.2.2 The following features are available in the chassis:

Color systems: PAL, SECAM ,NTSC(selectable)

Sound systems: D/K, B/G, I , M

236 programs preset,AV stereo,Hotel ,Biorhythm,child lock ,teletext (selectable)

3.2.3 The chassis mainly uses the following ICs and assemblies.

	Position	Type	Description
1	N200	AT24C08	EERPOM

2	N100	TDA9384PS/N3/3	For slim CRT, Small signal processor and micro control, no teletext
		TDA9353PS/N3/3	For slim CRT, Small signal processor and micro control, 1 page teletext
		TDA938 1PS/N3/3	Small signal processor and micro control, no teletext
		TDA9345PS/N3/3	Small signal processor and micro control, 1 page teletext
3	N601	TFA9842AJ	Audio power amplifier
4	N300	TDA4863AJ	slim CRT
		TDA4864AJ	Vertical scan output stage circuit
5	N801	STR-G5653	Switch-mode power supply control
6	A001	TAF5-C4I21/ TAF5-C4I23	IF 38MHz tuner
		TAF5-E4I22	IF 38.9MHz tuner
		TAF5-U2F22	IF 45.75MHz tuner

4. SERVICE DATA

4.1 TV signal processor TDA935X/8X PS-N3 series

4.1.1 GENERAL DESCRIPTION

The various versions of the TDA935X/8X/ PS-N3 series combine the functions of a video processor together with a -Controller and US Closed Caption decoder. Most versions have a Teletext decoder on board. The Teletext decoder has an internal RAM memory for 1 or 10 page text. The ICs are intended to be used in economy television receivers with 90 and 110 picture tubes. The ICs have supply voltages of 8 V and 3.3 V and they are mounted in an SDIP-64 envelope.

The features are given in the following feature list.

4.1.2 FEATURES TV processor

Available in TDA935X/8X PS versions

- Multi-standard vision IF circuit with alignment-free PLL demodulator
- Internal (switchable) time-constant for the IF-AGC circuit
- The mono intercarrier sound circuit has a selective FM-PLL demodulator which can be switched to the different FM sound frequencies (4.5/5.5/6.0/6.5 MHz). The quality of this system is such that the external band-pass filters can be omitted.
- The FM-PLL demodulator can be set to centre frequencies of 4.74/5.74 MHz so that a second sound channel can be demodulated. In such an application it is necessary that an external band pass filter is inserted.
- Integrated chrominance trap circuit
- Integrated luminance delay line with adjustable delay time
- Picture improvement features with peaking (with switchable centre frequency, depeaking, variable positive/negative overshoot ratio and video dependent coring) and blue- and black stretching. All features are available for CVBS, Y/C and YPBPR signals.
- Tint control for external RGB/YPBPR signals
- Integrated chroma band-pass filter with switchable centre frequency
- Only one reference (12 MHz) crystal required for the -Controller, Teletext- and the colour decoder
- Multi-standard colour decoder with automatic search system
- Internal base-band delay line
- Indication of the Signal-to-Noise ratio of the incoming CVBS signal
- A linear RGB/YUV/YPBPR input with fast blanking for external RGB/YUV sources. The synchronisation circuit can be connected to the incoming Y signal. The Text/OSD signals are internally supplied from the -Controller/Teletext decoder.
- RGB control circuit with 'Continuous Cathode Calibration', white point and black level off-set adjustment so that the colour temperature of the dark and the light parts of the screen can be chosen independently.
- 2 levels of contrast reduction of main picture possible during OSD/Text insertion ('halftone')
- OSD/Text gain reduction control
- Adjustable 'wide blanking' of the RGB outputs
- Horizontal synchronization with two control loops and alignment-free horizontal oscillator
- Vertical count-down circuit
- Vertical driver optimized for DC-coupled vertical output stages
- Horizontal and vertical geometry processing

- Horizontal and vertical zoom function for 16:9 applications
- Horizontal parallelogram and bow correction for large screen picture tubes
- Low-power start-up of the horizontal drive circuit
- Macrovision keying possibility for horizontal synchronisation.

Available in TDA935X/6X/8X PS versions

• A choice can be made between versions with mono intercarrier sound FM demodulator and versions with QSS IF amplifier.

- Source selection between the 'internal' CVBS and an external CVBS or Y/C signal

Controller

- 80C5 1 -controller core standard instruction set and timing
- 1 s machine cycle
- 32 - 128Kx8-bit late programmed ROM
- 3 - 12Kx8-bit Auxiliary RAM (shared with Display)
- Interrupt controller for individual enable/disable with two level priority
- Two 16-bit Timer/Counter registers
- One 16-bit Timer with 8-bit Pre-scaler
- WatchDog timer
- Auxiliary RAM page pointer
- 16-bit Data pointer
- Stand-by, Idle and Power Down modes
- 14 bits PWM for Voltage Synthesis Tuning
- 8-bit A/D converter
- 4 multiplexed inputs for the A/D converter and 5 PWM (6-bits) outputs for control of TV analogue signals (TDA95XX series)
- 4 pins which can be programmed as general I/O pin, ADC input or PWM (6-bit) output (TDA93XX series)

Data Capture

- Text memory for 1 or 10 pages
- In the 10 page versions inventory of transmitted Teletext pages stored in the Transmitted Page Table (TPT) and Subtitle Page Table (SPT)
- Data Capture for US Closed Caption
- Data Capture for 525/625 line WST, VPS (PDC system A) and Wide Screen Signalling (WSS) bit decoding
- Automatic selection between 525 WST/625 WST
- Automatic selection between 625 WST/VPS on line 16 of VBI
- Real-time capture and decoding for WST Teletext in Hardware, to enable optimized -processor throughput
- Automatic detection of FASTEXT transmission
- Real-time packet 26 engine in Hardware for processing accented, G2 and G3 characters
- Signal quality detector for video and WST/VPS data types

- Comprehensive teletext language coverage
- Full Field and Vertical Blanking Interval (VBI) data capture of WST data

Display

- Teletext and Enhanced OSD modes
- Features of level 1.5 WST and US Close Caption
- Serial and Parallel Display Attributes
- Single/Double/Quadruple Width and Height for characters
- Scrolling of display region
- Variable flash rate controlled by software
- Enhanced display features including overlining, underlining and italics
- Soft colours using CLUT with 4096 colour palette
- Globally selectable scan lines per row (9/10/13/16) and character matrix [12x10, 12x13, 12x16 (VxH)]
- Fringing (Shadow) selectable from N-S-E-W direction
- Fringe colour selectable
- Meshing of defined area
- Contrast reduction of defined area
- Cursor
- Special Graphics Characters with two planes, allowing four colours per character
- 32 software redefinable On-Screen display characters
- 4 WST Character sets (G0/G2) in single device (e.g. Latin, Cyrillic, Greek, Arabic)
- G1 Mosaic graphics, Limited G3 Line drawing characters
- WST Character sets and Closed Caption Character set in single

QUICK REFERENCE DATA

SYMBOL	PARAMETER	MIN.	TYP.	MAX.	UNIT
Supply					
Vp	supply voltages		8.0/3.3		V
Ip	supply current (VP = 8 V)		135		mA
Ip	supply current (VP = 3.3 V)		60		mA
Input voltages					
ViVIF(rms)	video IF amplifier sensitivity (RMS value)		75		V
ViSIF(rms)	QSS sound IF amplifier sensitivity (RMS value)		45		d B V
ViAUDIO(rms)	external audio input (RMS value)		500		mV
ViCVBS(p-p)	external CVBS/Y input (peak-to-peak value)		1.0		V
ViCHROMA(p-p)	external chroma input voltage (burst amplitude)		0.3		V

	(peak-to-peak value)				
ViRGB(p-p)	RGB inputs (peak-to-peak value)		0.7		V
ViY(p-p)	luminance input signal (peak-to-peak		1.4	/	V
	value)				
ViU(p-p) /	U / PB input signal (peak-to-peak		1.33 /		V
ViV(p-p) /	V / PR input signal (peak-to-peak		1.05 /		V
Output signals					
Vo(IFVO)(p-p)	demodulated CVBS output (peak-to-peak value)		2.0		V
Vo(QSSO)(rms)	sound IF intercarrier output in QSS versions (RMS value)		100		mV
Vo(AMOUT)(rms)	demodulated AM sound output in QSS versions (RMS value)		500		mV
Vo(CVBSO)(p-p)	selected CVBS output (peak-to-peak value)		2.0		V
Io(AGCOUT)	tuner AGC output current range	0		5	mA
VoRGB(p-p)	RGB output signal amplitudes (peak-to-peak value)		2.0		V
IoHOUT	horizontal output current	10			mA
IoVERT	vertical output current (peak-to-peak value)	1			mA

BLOCK DIAGRAM

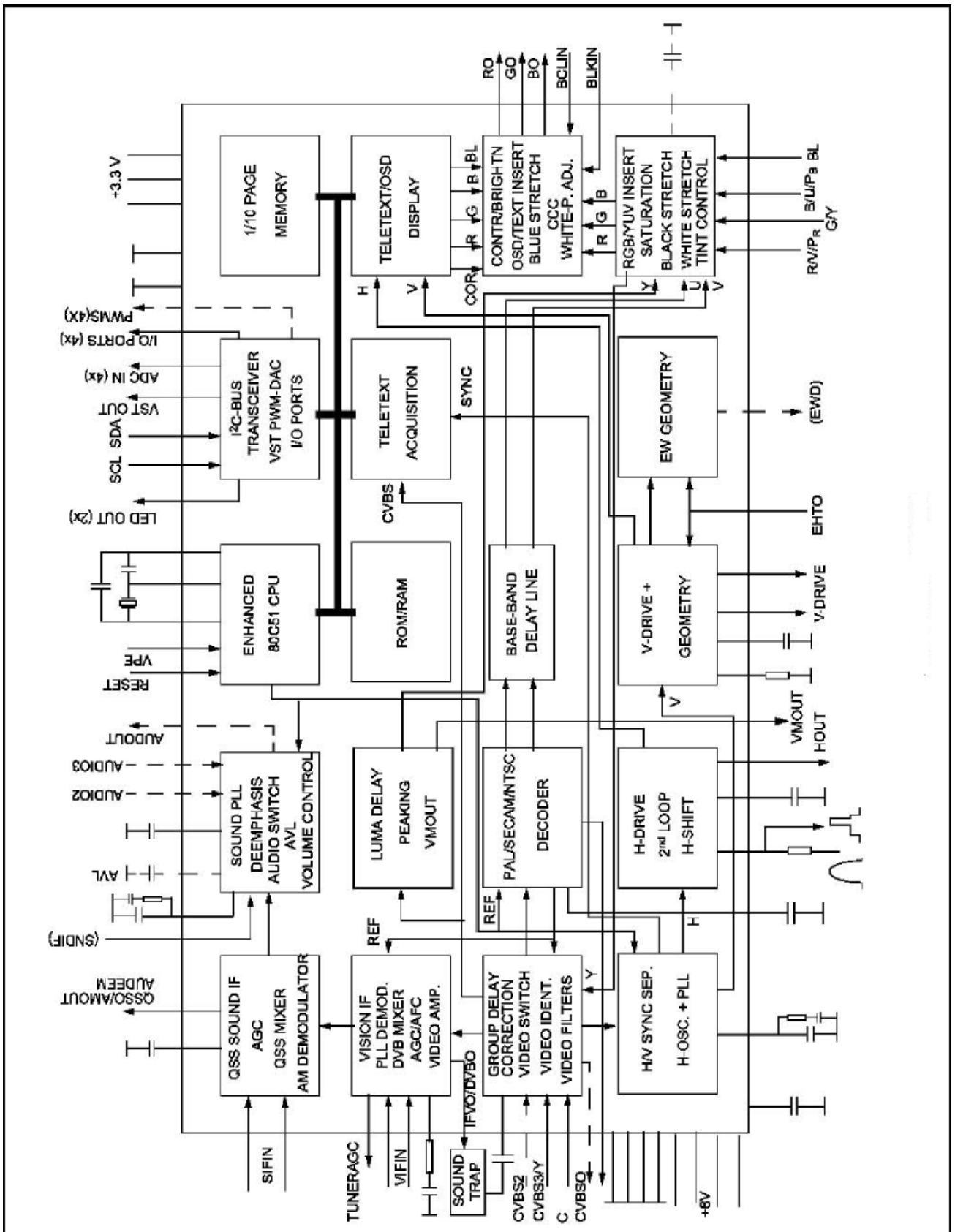

PINNING

SYMBOL	PIN	DESCRIPTION
P3.1/ADC1/PWM1	6	port 3.1 or ADC1 input or PWM1 output
P3.2/ADC2/PWM2	7	port 3.2 or ADC2 input or PWM2 output
P3.3/ADC3/PWM3	8	port 3.3 or ADC3 input or PWM3 output
VSSC/P	9	digital ground for -Controller core and periphery
P0.5	10	port 0.5 (8 mA current sinking capability for direct drive of LEDs)
P0.6/C VBSTD	11	port 0.6 (8 mA current sinking capability for direct drive of LEDs) or Composite video input. A positive-going 1 V(peak-to-peak) input is required
VSSA	12	digital ground of TV-processor
SECPLL	13	SE CAM PLL decoupling
VP2	14	2nd supply voltage TV-processor (+8V)
DECDIG	15	supply voltage decoupling of digital circuit of TV-processor
PH2LF	16	phase-2 filter
PH1LF	17	phase-1 filter
GND3	18	ground 3 for TV-processor
DECBG	19	bandgap decoupling
AVL/EWD (1)	20	Automatic Volume Levelling (90versions)/ E-W drive output (110versions)
VDRB	21	vertical drive B output
VDRA	22	vertical drive A output
IFIN1	23	IF input 1
IFIN2	24	IF input 2
IREF	25	reference current input
VSC	26	vertical sawtooth capacitor
AGCOUT	27	tuner AGC output
SIFIN1/A UDEEM (2)	28	SIF input 1 / audio deemphasis
SIFIN2/DECSDEM (2)	29	SIF input 2 / decoupling sound demodulator
GND2	30	ground 2 for TV processor
SNDPLL/SIFA GC (2)	31	narrow band PLL / AGC sound IF
AVL/REF0/SNDIF/AMOUT (2)	32	Automatic Volume Levelling / subcarrier reference output / sound IF input / AM output
HOUT	33	horizontal output
FBISO	34	flyback input/sandcastle output

<i>QSSO/AMOUT/ A UDEXT(2)</i>	35	<i>QSS intercarrier output / AM output / external audio input</i>
<i>EHTO</i>	36	<i>EHT/overvoltage protection input</i>
<i>PLLIF</i>	37	<i>IF-PLL loop filter</i>
<i>IFVO/SVO/DVBO</i>	38	<i>IF video output / selected CVBS output / DVB output</i>
<i>VP1</i>	39	<i>main supply voltage TV processor</i>
<i>CVBS1</i>	40	<i>internal CVBS input</i>
<i>GND</i>	41	<i>ground for TV processor</i>
<i>CVBS3/Y</i>	42	<i>CVBS3/Y input</i>
<i>C</i>	43	<i>chroma input</i>
<i>AUDOUT /</i>	44	<i>audio output / AM audio output (volume controlled)</i>
<i>INSSW2</i>	45	<i>2nd RGB / YUV insertion input</i>
<i>R2/V/PR-IN</i>	46	<i>2nd R input / V (R-Y) input / PR input</i>
<i>G2/Y-IN</i>	47	<i>2nd G input / Y input</i>
<i>B2/U/PB -IN</i>	48	<i>2nd B input / U (B-Y) input / PB input</i>
<i>BCLIN</i>	49	<i>beam current limiter input</i>
<i>BLKIN</i>	50	<i>black current input / V-guard input</i>
<i>RO</i>	51	<i>Red output</i>
<i>GO</i>	52	<i>Green output</i>
<i>BO</i>	53	<i>Blue output</i>
<i>VDDA</i>	54	<i>analog supply of Teletext decoder and digital supply</i>
<i>VPE</i>	55	<i>OTP Programming Voltage</i>
<i>VDDC</i>	56	<i>digital supply to core (3.3 V)</i>
<i>OSCGND</i>	57	<i>oscillator ground supply</i>
<i>XTALIN</i>	58	<i>crystal oscillator input</i>
<i>XTALOUT</i>	59	<i>crystal oscillator output</i>
<i>RESET</i>	60	<i>reset</i>
<i>VDDP</i>	61	<i>digital supply to periphery (+3.3 V)</i>
<i>P1.0/INT1</i>	62	<i>port 1.0 or external interrupt 1 input</i>
<i>P1.1/T0</i>	63	<i>port 1.1 or Counter/Timer 0 input</i>
<i>P1.2/INT0</i>	64	<i>port 1.2 or external interrupt 0 input</i>
<i>P1.3/T1</i>	1	<i>port 1.3 or Counter/Timer 1 input</i>
<i>P1.6/SCL</i>	2	<i>port 1.6 or I2C-bus clock line</i>
<i>P1.7/SDA</i>	3	<i>port 1.7 or I2C-bus data line</i>
<i>P2.0/TPWM</i>	4	<i>port 2.0 or Tuning PWM output</i>
<i>P3.0/ADC0/PWM0</i>	5	<i>port 3.0 or ADC0 input or PWM0 output</i>

4.2 TFA9842AJ

2-channel audio amplifier with volume control (SE: 1 W to 7.5 W)

4.2.1 General description

The TFA9842AJ contains two identical audio power amplifiers. The TFA9842AJ can be used as two

Single-Ended (SE) channels with a volume control. The maximum gain is 26 dB. The TFA9842AJ comes in a 9-pin DIL-bent-SIL (DBS9P) power package. The TFA9842AJ contains a unique protection circuit that is solely based on multiple temperature measurements inside the chip. This gives maximum output power for all supply voltages and load conditions with no unnecessary audio holes. Almost any supply voltage and load impedance combination can be made as long as thermal boundary conditions (number of channels used, external heatsink and ambient temperature) allow it.

4.2.2 Features

2 Channel SE: 1 W to 7.5 W operation possibility

Soft clipping

Input clamps

Volume control

Standby and mute mode

No on/off switching plops

Low standby current

High supply voltage ripple rejection

Outputs short-circuit protected to ground, supply and across the load

Thermally protected

4.2.3 Block diagram of TFA9842AJ

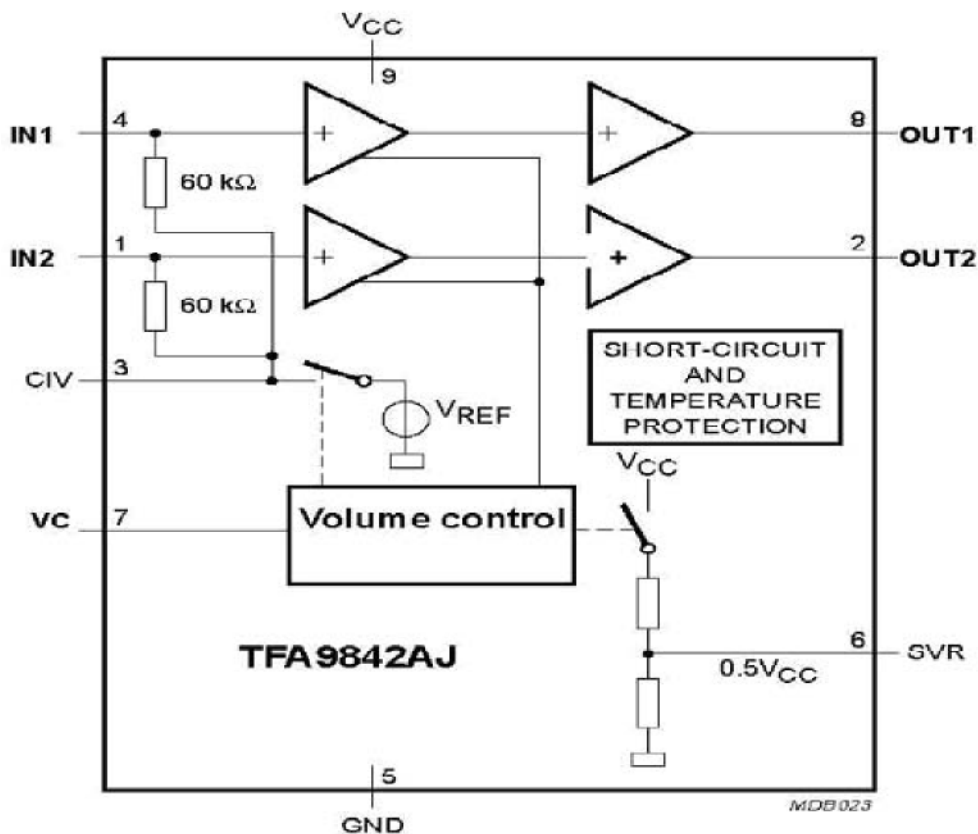

4.2.4 Pinning

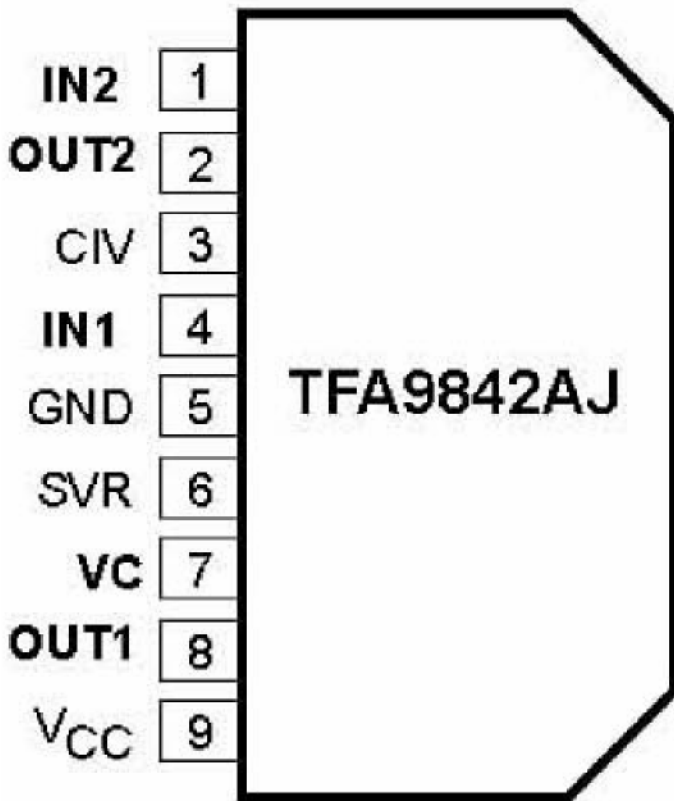

4.2.5 Pin description

Symbol	Pin	Description
IN2	1	input 2
OUT2	2	loudspeaker terminal 2
CIV	3	common input voltage decoupling
IN1	4	input 1
GND	5	ground
SVR	6	half supply voltage decoupling (ripple rejection)
VC	7	volume control input (standby, mute and volume control)
OUT1	8	loudspeaker terminal 1
V _{CC}	9	supply voltage

4.3 VERTICAL SCAN OUTPUT STAGE CIRCUIT

TDA4863AJ/TDA4864AJ

4.3.1 FEATURES

TDA4863AJ: Output current up to 3 A (p-p)

TDA4864AJ: Output current up to 2.5A (p-p)

4.3.2 GENERAL DESCRIPTION

The TDA4863AJ and TDA4864AJ are deflection boosters for use in vertical deflection systems for frame frequencies up to 200 Hz.

The TDA4863AJ or TDA4864AJ needs a separate flyback supply voltage, so the supply voltages are independently adjustable to optimize power consumption and flyback time.

For the TDA4863AJ or TA4864AJ the flyback supply voltage will be generated internally by doubling the supply voltage and therefore a separate flyback supply voltage is not needed.

4.3.3 Block diagram of TDA4863AJ and TDA4864AJ

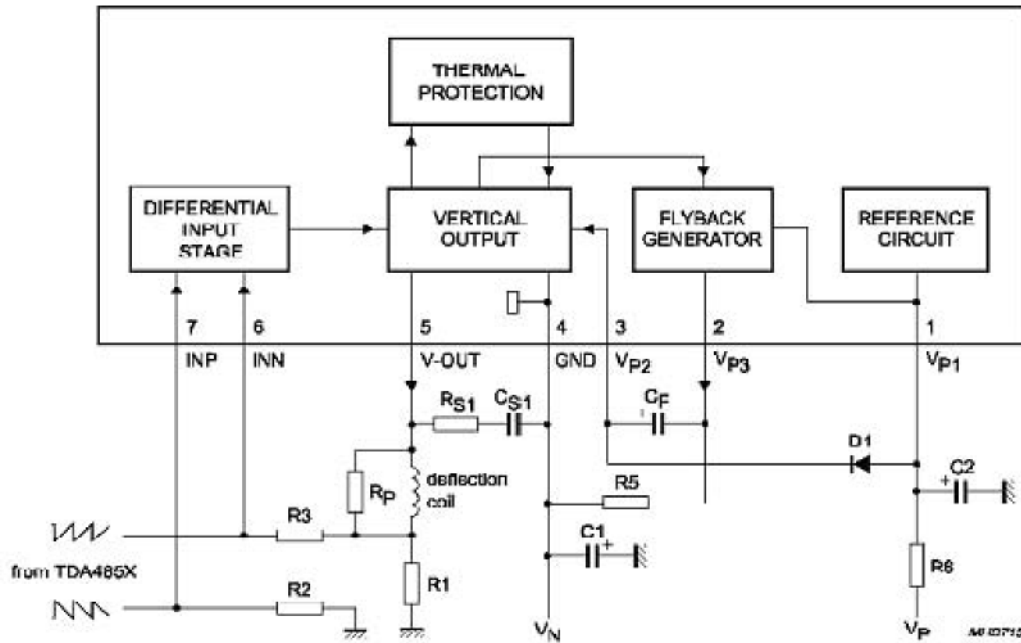

4.3.4 pinning

PIN	SYMBOL	DESCRIPTION
1	VP1	positive supply voltage 1
2	VP3	flyback generator output
3	VP2	supply voltage 2 for vertical output
4	GND	ground or negative supply voltage
5	V-OUT	vertical output
6	INN	inverted input of differential input stage
7	INP	non-inverted input of differential input stage

4.4 EEPROM AT24C08

4.4.1 Features

Data EEPROM internally organized as 1024/2048 bytes and 64/128 pages×16 bytes

Page protection mode, flexible page-by-page hardware write protection -Additional protection EEPROM of 64/128 bits, bit per data page 1-Protection setting for each data page by writing its protection bit -Protection management without switching WP pin

Low power CMOS

Vcc=2.7 to 5.5V operation

Two wire serial interface bus, IIC-Bus compatible

Filtered inputs for noise suppression with Schmitt trigger

Clock frequency up to 400 kHz

High programming flexibility

- Internal programming voltage
- Self timed programming cycle including erase
- Byte-write and page-write programming, between 1 and 16 bytes
- Typical programming time 6ms(< 10ms) for up to 16 bytes

High reliability

- Endurance 10⁶ cycles 1)
- Data retention 40 years 1)
- ESD protection 4000 V on all pins

8 pin DIP/DSO packages

Available for extended temperature ranges

- Industrial: -40 to +85
- Automotive: -40 to +125

4.4.2 Pin Description

SERIAL CLOCK (SCL): The SCL input is used to positive edge clock data into each EEPROM device and negative edge clock data out of each device.

SERIAL DATA (SDA): The SDA pin is bi-directional for serial data transfer. This pin is open-drain driven and may be wire-ORed with any number of other open-drain or open-collector devices.

The AT24C08 only uses the A2 input for hardwire addressing and a total of two 8K devices may be addressed on a single bus system. The A0 and A1 pins are no connects.

4.4.3 Memory Organization

T24C08, 8K SERIAL EEPROM: Internally organized with 64 pages of 16 bytes each, the 8K requires a 10-bit data word address for random word addressing.

4.4.4 Block Diagram

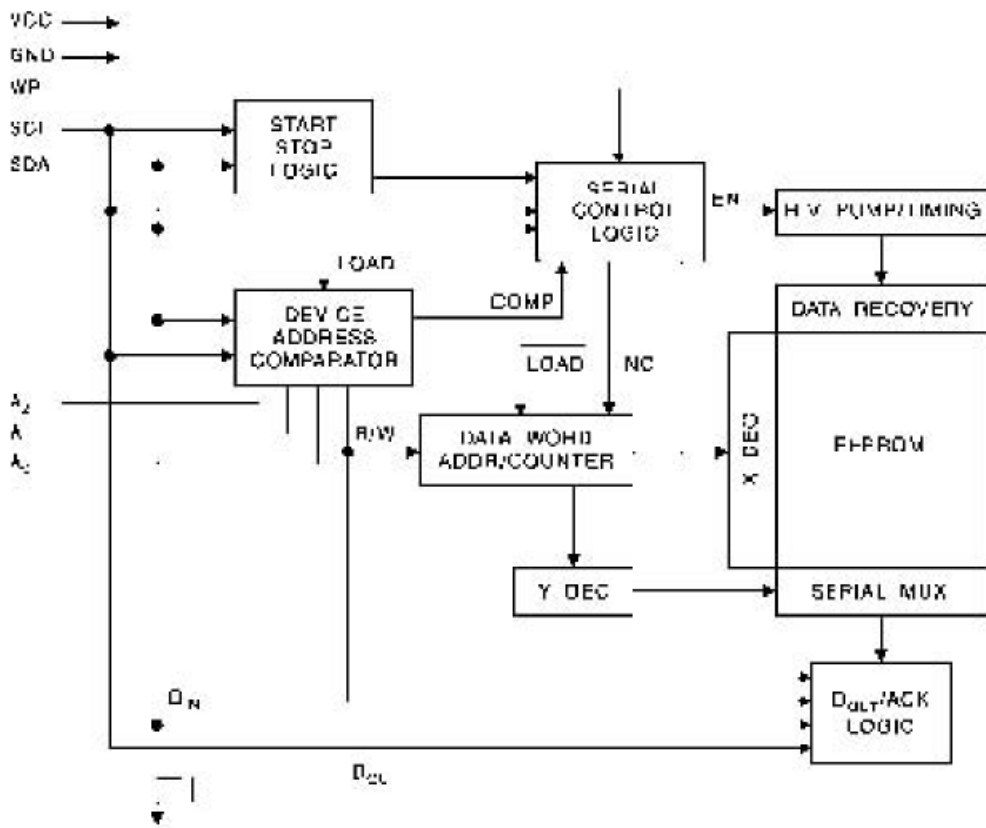

4.5 SWITCH-MODE POWER SUPPLY IC STRG5653

4.5.1 General Description

The STRG5653 is part of the STRG5600 series thick-film ICs for switch-mode power supply incorporating power MOSFET with a high-precise error amplifier. The ICs feature fewer external components, small-size and standard power supply.

4.5.2 Block Diagram

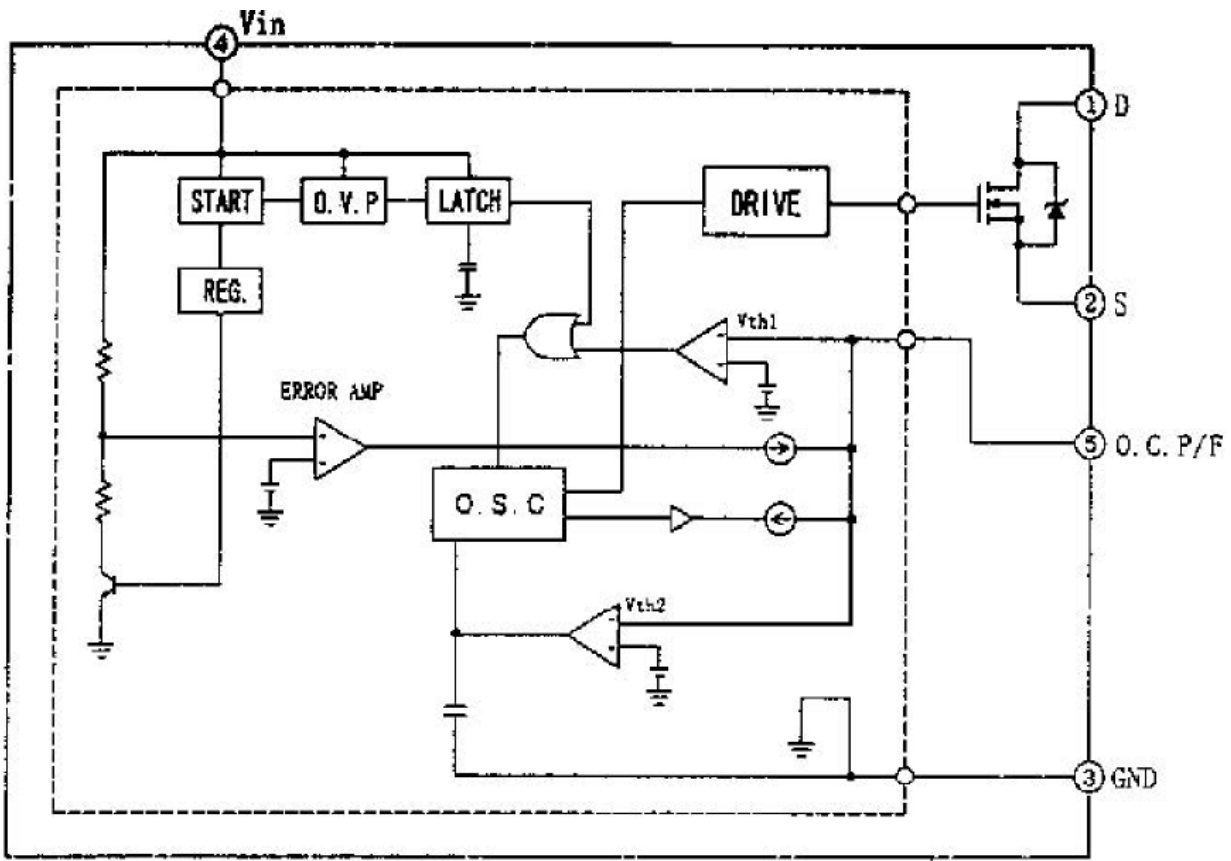

4.5.3 Function of Terminal

Terminal No.	Symbols	Description	Functions
1	D	Drain Terminal	MOS FET drain
2	S	Source Terminal	MOS FET source
3	GND	Ground Terminal	Ground
4	VIN	Power supply Terminal	Input of power supply for control
5	O.C.P/F.B	Overcurrent/Feedback	Input of overcurrent detection signal