



## INSTALLATION, SERVICE AND MAINTENANCE INSTRUCTIONS

# DIN-FOOD



**INOXPA, S.A.**

c/Telers, 54 Apto. 174

E-17820 Banyoles

Girona (Spain)

Tel. : (34) 972 - 57 52 00

Fax. : (34) 972 - 57 55 02

Email: [inoxpa@inoxpa.com](mailto:inoxpa@inoxpa.com)

[www.inoxpa.com](http://www.inoxpa.com)





## EC DECLARATION OF CONFORMITY

(In accordance with Directive 98/37/EC, annex II, part A)

We, the manufacturer:      INOXPA, S.A.  
   c/ Telers, 54  
   17820 Banyoles (Girona) - Spain

Hereby declare that the products

<u>CENTRIFUGAL PUMP</u>	<u>DIN-FOOD</u>	<u>2008</u>
Name	Type	Year of Manufacture

are in conformity with the provisions of the Council Directives:

**Machine Directive** 98/37/EC and comply with the essential requirements of said Directive and the harmonised standards:

UNE-EN ISO 12100-1/2:2003  
UNE-EN 1050:1996  
UNE-EN 809/A1/AC:2001  
UNE-EN 294/A1/AC:1993  
UNE-EN 953:1997  
UNE-EN 563/A1/AC:2000

**Low-Voltage Directive** 2006/95/CE (replacing Directive 73/23/CE) and conform to UNE-EN 60204-1:1997 and UNE-EN 60034-1/A11:2002.

**Electromagnetic Compatibility Directive** 2004/108/CE (replacing Directive 89/336/CE) and conform to UNE-EN 60034-1/A11:2002.

In conformity with **Regulation (CE) No. 1935/2004** on materials and objects intended to come into contact with foodstuffs (repealing 89/109/EEC), in accordance with which the materials in contact with the product do not transfer its constituents to the foodstuffs in quantities large enough to put human health at risk.

**Declaration of Incorporation** (Directive 98/37/EC, annex II, part B):

**The aforementioned equipment shall not be commissioned until the machine in which they will be incorporated has been declared as being in conformity with the Machine Directive.**

Banyoles, July 2008

  
Marc Pons Bague      Technical Manager

# 1. Safety

## 1.1. INSTRUCTIONS MANUAL

This manual contains information about the receipt, installation, operation, assembly, disassembly and maintenance of the DIN-FOOD pump.

The information published in the instruction manual is based on updated information.

INOXPA reserves the right to modify this instruction manual without prior notice.

## 1.2. START-UP INSTRUCTIONS

This Instructions Manual contains essential and useful information for properly operating and maintaining your pump.

Read these instructions carefully before starting up the pump; become familiar with the operation and use of your pump and follow the instructions closely. These instructions should be kept in a safe location near the installation.

## 1.3. SAFETY

### 1.3.1. Warning symbols



Danger for persons in general



Danger of injury caused by rotating equipment parts



Electrical danger



Danger! Caustic or corrosive agents



Danger! Suspended loads



Danger to the correct operation of the equipment



Commitment to safety at the workplace



Protective goggles requirement

## 1.4. GENERAL SAFETY INSTRUCTIONS



Read this Instructions Manual carefully before installing the pump and starting it up. Contact INOXPA in case of doubt.

### 1.4.1. During installation



The *Technical Specifications* of Chapter 8 should always be observed.

Never start up the pump before it has been connected to the pipeline.

Do not start up the pump if the pump cover is not placed.

Check that the motor specifications meet the requirements, especially when working under conditions that involve the risk of explosion.



During the installation, all the electric work should be carried out by authorised personnel.

### 1.4.2. During operation



The *Technical Specifications* of Chapter 8 should always be observed. Under no circumstances can the limit values specified be exceeded.

**NEVER** touch the pump or the pipes during operation when the pump is being used to decant hot fluids or when it is being cleaned.



The pump contains moving parts. Never place your fingers inside the pump while the pump is in operation.



**NEVER** operate the pump with the suction and delivery valves closed.

**NEVER** spray the electrical motor directly with water. The standard protection of the motor is IP-55: Protection against dust and sprayed water.

#### 1.4.3. During maintenance



The *Technical Specifications* of Chapter 8 should always be observed.

**NEVER** dismantle the pump before the pipes have been emptied. Remember that some of the fluid will always remain in the pump housing (when no drainage is provided). Note that the pumped fluid may be dangerous or very hot. Consult the regulations in effect in each country for these cases.

Do not leave parts loose on the floor.



**ALWAYS** disconnect the pump from the power supply before starting maintenance work. Remove the fuses and disconnect the cables from the motor terminals.

**All electrical work should be carried out by authorised personnel.**

#### 1.4.4. Compliance with the instructions

Any non-fulfilment of the instructions may result in a risk for the operators, the environment and the machine, and may result in the loss of your right to claim damages.

This non-fulfilment may result in the following risks:

- Failure of important functions of the machines/plant.
- Failure of specific maintenance and repair procedures.
- Possibility of electric, mechanical and chemical risks.
- Will place the environment in danger due to the release of substances.

#### 1.4.5. Guarantee

Any warranty provided shall immediately be cancelled and void ipso jure, and INOXPA shall be compensated for any product liability claim from third parties, if:

- the service and maintenance work was not carried out in accordance with the service instructions, or the repair work has not been carried out by our personnel or it has been conducted without our written authorization;
- our equipment has been changed without prior written authorization;
- the parts or lubricants used are not original INOXPA parts and products;
- the materials were used incorrectly or negligently, or not in accordance with these instructions and their intended use;
- pump parts were damaged by excessive pressure owing to the lack of a safety valve.

The General Delivery Terms already provided also apply.



**No change can be made to the equipment without prior discussion with the manufacturer. For your safety, please use original spare parts and accessories.**

**The use of other parts will exempt the manufacturer from any liability.**

**The service terms can only be changed with prior written authorisation from INOXPA.**

Please do not hesitate to contact us in case of doubts or more complete explanations are required on specific data (adjustments, assembly, disassembly, etc.).

## 2. Table of Contents

<b>1. Safety</b>	
1.1. Instructions manual.....	3
1.2. Start-up instructions .....	3
1.3. Safety.....	3
1.4. General safety instructions.....	3
<b>2. Table of Contents</b>	
<b>3. Información General</b>	
3.1. Description.....	7
3.2. Operating principle .....	7
3.3. Application .....	7
<b>4. Installation</b>	
4.1. Pump reception .....	9
4.2. Transport and storage .....	9
4.3. Location.....	10
4.4. Coupling .....	10
4.5. Pipes .....	¡Error! Marcador no definido.
4.6. Pressurisation tank .....	11
4.7. Electrical installation .....	11
<b>5. Start-up</b>	
5.1. Start-up .....	13
<b>6. Operating Problems</b>	
<b>7. Maintenance</b>	
7.1. General information.....	15
7.2. Torque.....	15
7.3. Lubrication .....	15
7.4. Storage.....	15
7.5. Cleaning .....	16
7.6. Disassembly / assembly of the pump.....	17
<b>8. Technical Specifications</b>	
8.1. Technical specifications.....	25
8.2. Weights .....	25
8.3. DIN-FOOD dimensions (bare shaft) .....	26
8.4. DIN-FOOD dimensions (bare shaft, with baseplate).....	27
8.5. DIN-FOOD dimensions (close-coupled) .....	28
8.6. DIN-FOOD dimensions (close-coupled, with shroud).....	29
8.7. DIN-FOOD pump (bare shaft).....	30
8.8. DIN-FOOD pump (close-coupled) .....	31
8.9. DIN-FOOD pump (bare shaft) cross-section. ....	32
8.10. DIN-FOOD (bare shaft). Parts list .....	33

8.11. DIN-FOOD pump (close-coupled) cross-section.....	34
8.12. DIN-FOOD (close-coupled ). Parts list .....	35
8.13. DIN-FOOD flushed mechanical seal (bare shaft) .....	36
8.14. DIN-FOOD flushed mechanical seal (close-coupled, size 160 and 180 motors).....	37
8.15. DIN-FOOD flushed mechanical seal (close-coupled, size 200 motors).....	38
8.16. DIN-FOOD double mechanical seal (bare shaft) .....	39

## 3. Información General

### 3.1. DESCRIPTION

INOXPA DIN-FOOD series centrifugal pumps are manufactured with a cold-stamped thickplate and volute body. The parts in contact with the product are manufactured in AISI 316L stainless steel, internal finish is n Ra 0.8.

The DIN-FOOD centrifugal pump is built with a bare shaft or close-coupled construction with a shrouded motor, axial suction and radial discharge, connections with DIN-11864-2-B PN-10 flanges. The impeller is of a half-open design with double curvature and manufactured in a single piece. The mechanical seal is balanced and completely sanitary; the springs are protected to prevent contact with the product. The material of the wear surfaces is silicon carbide and graphite, with EPDM gaskets in the standard version.

The motor complies with IEC standards, IP-55 protection, F-class insulation. Three-phase power 220-240 / 380-420 V or 380-420 / 660 V at 50 Hz, depending on power supply. On demand, motors suitable for operating in explosive environments can be provided. Depending on the environmental conditions, the motors can be flameproof (EExd) or enhanced-safety (EExe) motors. The DIN-FOOD series model was developed specifically to meet all hygienic requirements required by the food industry. In terms of hygiene, reliability and durability, the entire range meets all the requirements imposed by the aforementioned industries. Its design enables the highest level of interchangeability of parts.

This equipment is suitable for use in the food-processing industry.

### 3.2. OPERATING PRINCIPLE

Housed inside the casing, the impeller rotates in conjunction with the pump shaft and it is comprised of varying number of blades, depending on the pump model.

With this arrangement, the impeller blades convey energy to the fluid in the form of kinetic energy and pressure energy. This pump is not reversible by simple reversal of the direction of rotation. The direction of rotation is clockwise when the pump is viewed from the rear side of the motor.

### 3.3. APPLICATION

As a general rule, standard version DIN-FOOD pumps are mainly used in the food-processing industries for transferring fluids. Various impeller diameters and speeds of the hydraulic specifications are provided for each pump type. The characteristics charts also show the required absorbed power and NPSH.

#### 3.3.1. Range of application

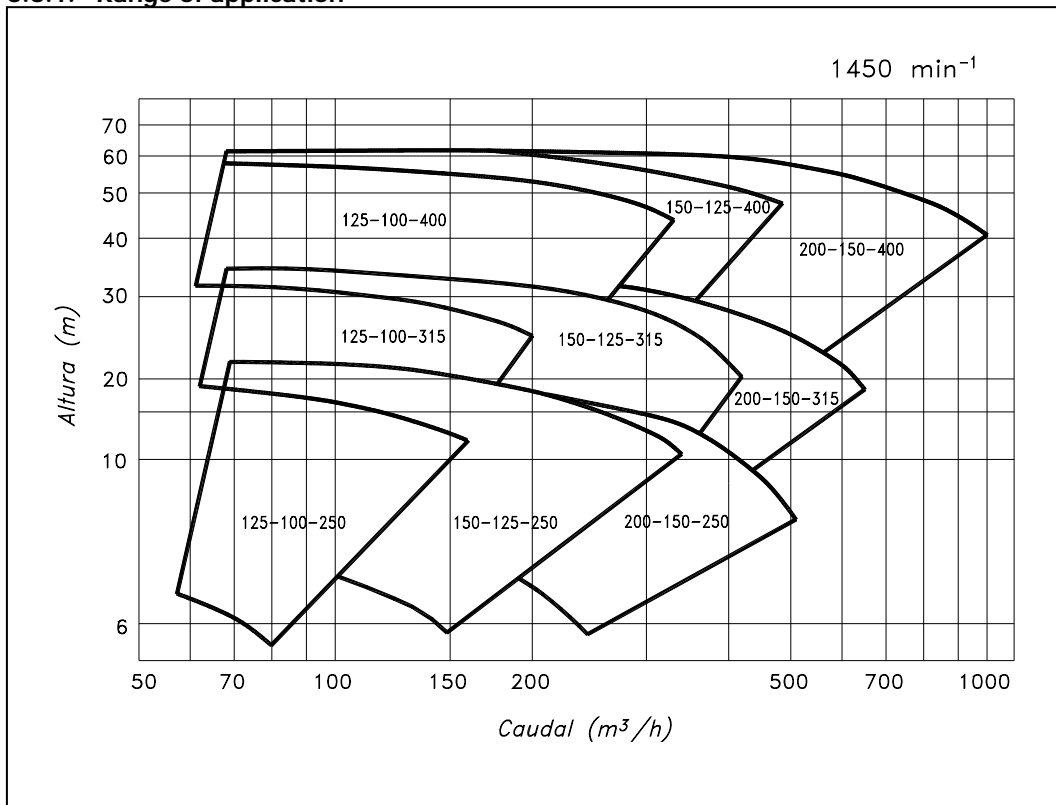

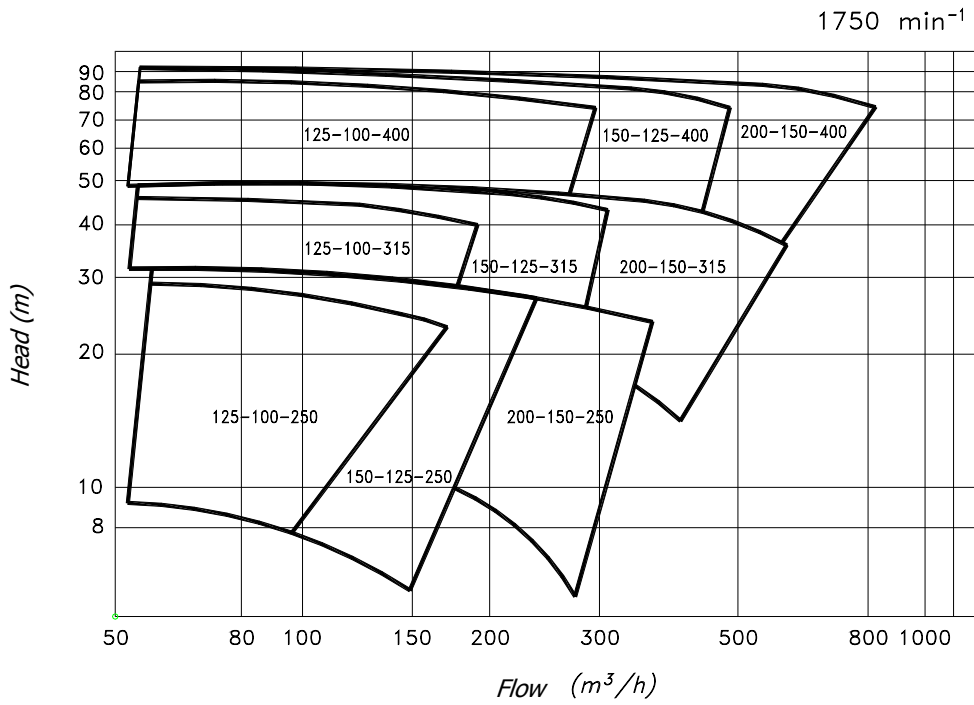

Each pump has performance limits. The pump was selected for certain pumping conditions at the time the order was placed. INOXPA shall not be liable for any damage resulting from the incompleteness of the information provided by the purchaser (nature of the fluid, rpm, etc.).



# 4. Installation

## 4.1. PUMP RECEPTION



**INOXPA cannot be held responsible for the damage sustained by the equipment during transport or unpacking. Visually check that the packaging is not damaged.**

The pump will be accompanied by the following documents:

- Dispatch notes.
  - Pump Instructions and Service Manual.7
  - Motor Instructions and Service Manual (\*)
- (\*) when the pump is supplied with a motor by INOXPA.

Unpack the pump and check the following:

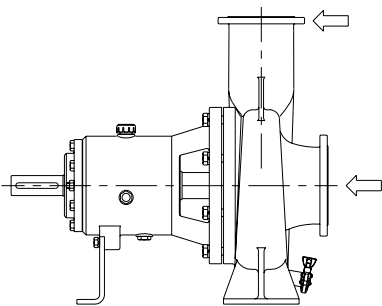

- The pump suction and delivery connections, remove the remains of any packaging materials.
- Check that the pump and the motor have not suffered any damage.
- If the equipment is not in good condition and/or any part is missing, the carrier should draw up a report accordingly as soon as possible.

### 4.1.1. Pump identification

		INOXPA S.A. C. Telers, 54 · P.O. BOX 174 17820 BANYOLES · GIRONA (SPAIN) Tel. 972 57 52 00 · Fax 972 57 55 02	CE
TIPO <input type="text"/>		AÑO <input type="text"/>	Serial number <input type="text"/>
KW <input type="text"/> min <sup>-1</sup> <input type="text"/>	Nº <input type="text"/>	V <input type="text"/> Hz <input type="text"/>	
QM <sup>3</sup> /h <input type="text"/>	Hm <input type="text"/>	øRODETE <input type="text"/>	

Pump plate

## 4.2. TRANSPORT AND STORAGE



**DIN-FOOD pumps are often too heavy to be handled and stored manually.**

Lift the pump as shown below:

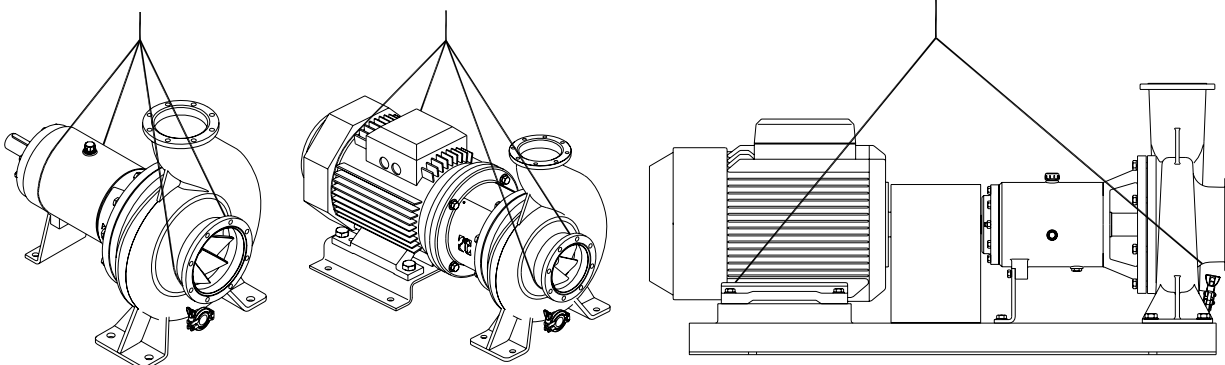

### 4.3. LOCATION

Place the pump as close as possible to the suction tank, and if possible below the product level.

Place the pump so as to allow sufficient space around it to access the pump and the motor. (See Chapter 8 *Technical Specifications* for dimensions and weight).

Set up the pump on a flat, level surface.

The foundation must be rigid, horizontal, flat and vibration-proof.



**Install the pump so as to allow sufficient ventilation.**

**If the pump is installed outdoors, it should be protected by a roof. Its location should enable easy access for any inspection or maintenance operations.**

### 4.4. COUPLING

For the selection and fitting of couplings, please refer to the supplier's manual. In some cases, the starting torque of positive-displacement pumps can be quite high. Therefore, the chosen coupling should be 1.5 to 2 times the recommended torque.

#### Alignment

The shafts of the pump unit and the pump transmission are aligned correctly when assembled at our factory.



**Check the alignment of the pump unit after installation.**

Place a straight-edge ruler (A) on the coupling: the ruler must be in contact with both halves of the coupling over its entire length. See illustration.

Repeat the check, this time on both sides of the coupling, close to the shaft. For the sake of accuracy, this check should also be performed using an outside calliper (B) on two diametrically opposed points on the exterior surfaces of the two halves of the coupling.

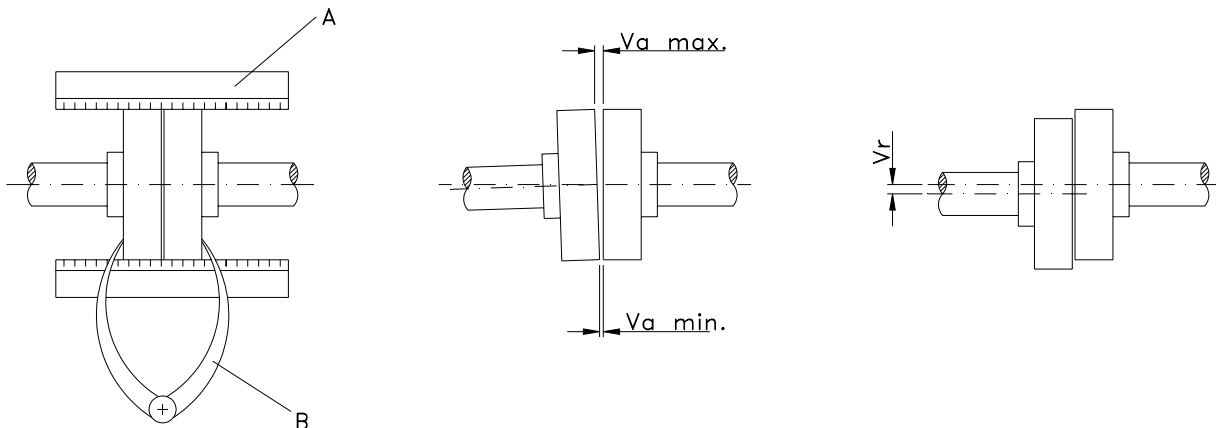

Maximum alignment deviations:

Exterior diameter of the coupling (mm)	Minimum Va. [mm]	Maximum Va. [mm]	Max. Va. - Min. Va. [mm]	Var. [mm]
70 - 80	2	4	0,13	0,13
81 - 95	2	4	0,15	0,15
96 - 110	2	4	0,18	0,18
111 - 130	2	4	0,21	0,21
131 - 140	2	4	0,24	0,24
141 - 160	2	6	0,27	0,27
161 - 180	2	6	0,3	0,3
181 - 200	2	6	0,34	0,34
201 - 225	2	6	0,38	0,38

#### 4.5. PIPES

- As a general rule, the suction and delivery pipes should be fitted in straight sections, with the least possible number of bends and fittings, in order to minimise pressure loss caused by friction.
- Ensure that pump inlet and outlet fittings are properly aligned with the piping and of a similar diameter to the pump connections.
- Place the pump as close as possible to the suction tank, if possible below the fluid level, or even below the tank, to achieve the maximum static suction head.
- Place pipes supports as close as possible to the pump suction inlet and delivery outlet.

##### 4.5.1. Shut-off valves

The pump can be isolated for maintenance purposes. Shut-off valves should be fitted to the pump suction and delivery connections.

These valves should ALWAYS be open when the pump is operating.

#### 4.6. PRESSURISATION TANK

For models with a double mechanical seal, a pressurisation tank must be installed.



**ALWAYS** install a pressurisation tank 1 to 2 meters above the pump shaft. See Figure 4.6.1.

**ALWAYS** connect the cooling fluid inlet to the lower connection of the seal chamber. Therefore, the outflow of the cooling liquid will be through the upper connection of the chamber. See Figure 4.6.1.

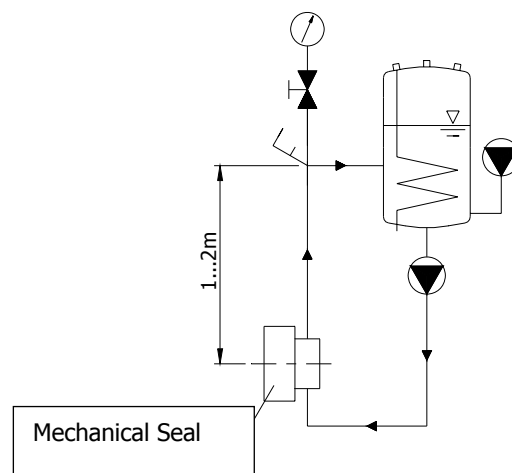

Figure 4.6.1: Pressurisation tank installation diagram

For more information on the pressurisation tank (installation, operation, maintenance, etc.), see the manufacturer's instructions manual.

#### 4.7. ELECTRICAL INSTALLATION



The connection of the electrical motors must be performed by qualified personnel. Take all necessary measures to prevent damage to connections and cables.



The electrical equipment, terminals and components of the control systems may still contain electric current when switched off. Contact with them may be dangerous for operators or cause irreversible damage to the equipment.

Before opening the pump, make sure that the electrical circuit is switched off.

- Connect the motor following the manufacturer's instructions.
- Check the direction of rotation (see the label on the pump).

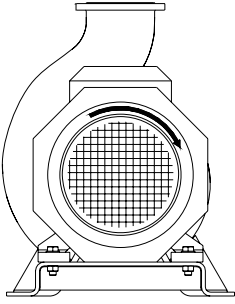

Start up the pump motor briefly. Make sure, by looking at the pump from the rear, that the motor fan is rotating in a clockwise direction.



**ALWAYS** check the direction of rotation of motor with fluid inside de pump.

For models with a seal chamber, **ALWAYS** make sure that the chamber is full of liquid before checking the rotation direction.

# 5. Start-up



Before starting the pump, thoroughly read the instructions provided in Chapter 4. *Installation*.

## 5.1. START-UP



Read Chapter 8 *Technical Specification* thoroughly. INOXPA cannot be held responsible for the incorrect use of the equipment.



**NEVER** touch the pump or the pipes when hot fluid is being pumped.

### 5.1.1. Checks before starting up the pump

- Fully open the shut-off valves on the suction and delivery pipes.
- Check the pump oil level. Fill with the necessary amount of oil so that the level is in the centre of the sight glass (If starting up for the first time: pumps are delivered with oil in the box. However, it is important to always remember to conduct this check).
- If the fluid does not flow into the pump, prime the pump with fluid to be pumped.



The pump must **NEVER** be run dry.

- Check that the motor direction of rotation is correct.

### 5.1.2. Checks when starting up the pump

- Check that the pump is not making any unusual noises.
- Check that the absolute inlet pressure is high enough to avoid cavitation in the pump. See the curve to determine the minimum pressure required above steam pressure (NPSHr).
- Check the flow pressure.
- Check that there are no leaks through the sealed areas.



A shut-off valve on the suction pipe must not be used to regulate flow. Shut-off valves must be fully open during operation.



Check the motor power consumption to avoid electric overload.

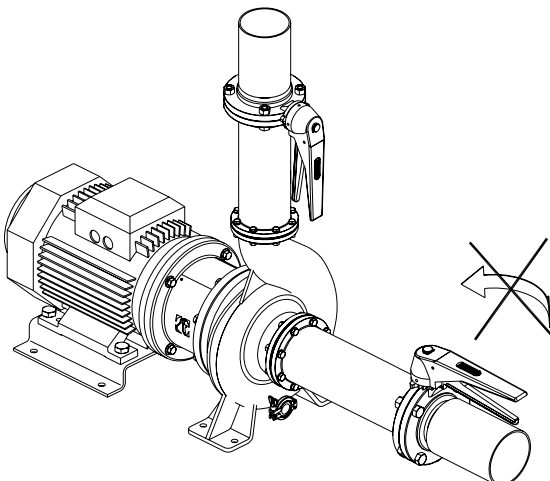

Reduce the flow and the power consumed by the motor:

- Regulating the flow to the pump delivery.
- Decreasing motor speed.

## 6. Operating Problems

The following table provides solutions to problems that might arise during pump operation. The pump is assumed to have been properly installed and correctly selected for the application. Please contact INOXPA if technical assistance is required.

Operating Problems	Probable causes
Motor overload	8, 9, 13, 14, 20, 21, 22, 23, 24.
The pump does not provide enough flow or pressure	1, 2, 4, 5, 7, 9, 10, 17, 19.
No pressure on the delivery side	2, 3, 6, 18.
Uneven delivery flow / pressure	1, 2, 4, 5, 6, 9.
Noise and vibration	2, 4, 5, 6, 7, 8, 9, 10, 13, 14, 15, 20, 21, 22, 23, 24.
The pump gets clogged	9, 10, 13, 14, 15, 20, 21, 22, 24.
Overheated pump	8, 9, 10, 13, 14, 15, 20, 21, 22, 23, 24.
Abnormal wear	4, 5, 10, 14, 15, 20, 24.
The mechanical seal is leaking.	11, 12, 16.

Probable causes	Solutions
1 Wrong direction of rotation	Reverse the direction of rotation.
2 NPSH is not high enough	Increase the available NPSH: - Place the suction tank higher - Place the pump lower - Reduce steam pressure - Increase the diameter of the suction pipe - Shorten and simplify the suction pipe
3 Pump not drained	Drain or fill
4 Cavitation	Increase suction pressure (see also 2)
5 Air is sucked in by the pump.	Check the suction pipe and all its connections
6 Clogged suction tube	Check the suction pipe and all its filters, if any
7 Delivery pressure too high	If necessary, reduce pressure losses, e.g. by increasing the diameter of the tube
8 Flow too high	Decrease the flow: - Reduce the flow by means of a diaphragm. - Partially shut off the delivery valve. - Trim impeller. - Reduce speed.
9 Fluid viscosity too high	Reduce the viscosity, e.g. by heating the fluid
10 Fluid temperature too high	Reduce the temperature by cooling the fluid.
11 Mechanical seal damaged or worn.	Replace the seal
12 O-rings unsuitable for the fluid.	Fit suitable O-rings after checking with the supplier.
13 The impeller scrapes.	- Reduce temperature - Reduce suction pressure - Adjust impeller / cover clearance.
14 Taught tubes	Connect the tubing to the pump avoiding taughtness.
15 Foreign particles in the fluid	Fit a filter to the suction tube
16 The mechanical seal spring tension is too low	Adjust as indicated in this Manual
17 Pump speed too low	Increase speed.
18 The cut-off valve on the suction side is closed	Check and open
19 Delivery pressure too low	Increase pressure: - Increase impeller diameter. - Increase the pump speed.
20 Bearings are worn.	Replace bearings; service the pump
21 Insufficient lubricating oil	Refill with lubricating oil
22 Unsuitable lubricating oil	Use suitable lubricating oil
23 Misaligned coupling	Align the coupling
24 Pump and/or motor not attached to the bedplate.	Attach the pump and/or motor and check that the tubes are connected without taughtness and align the coupling



**If the problems persist, stop using the pump immediately. Contact the pump manufacturer or their representative.**

# 7. Maintenance

## 7.1. GENERAL INFORMATION

Like any other machine, this pump requires maintenance. The instructions contained in this manual cover the identification and replacement of spare parts. The instructions have been prepared for maintenance personnel and for those responsible for the supply of spare parts.



Please read Chapter 8 *Technical Specification*.

All replaced material should be duly eliminated/recycled according to the directives in effect in the area.



**ALWAYS disconnect the pump from the power supply before undertaking maintenance work.**

### 7.1.1. Checking the mechanical seal

Regularly check that there are no leaks in the shaft area. If there are leaks through the mechanical seal, replace it following the instructions given in the Assembly and Dismantling section.

## 7.2. TIGHTENING TORQUE

Material	Torque value [N.m.]								
	M5	M6	M8	M10	M12	M14	M16	M18	M20
8.8	6	10	25	49	86	135	210	290	410
A2	5	9	21	42	74	112	160	210	300

## 7.3. LUBRICATION

The bearings are lubricated by means of an oil bath.

The pumps are supplied with oil.

- Check the oil level regularly, e.g. weekly or after every 150 hours of service.
- The first oil change should be conducted after 150 hours of service.
- Following this, the oil should be changed after every 2,500 hours of service or at least once a year under normal operating conditions.

When the oil is changed, the oil box should be filled up to the level in the centre of the sight-glass.



**Do not overfill the support with oil.**

Leave the pump in the stop position for a while and then check the oil level; if necessary, add a little more oil.

Oil for ambient temperatures of 5 to 50°C: ISO VG 68.

PUMP TYPE	Support oil capacity [l.]
125-100-250 125-100-315 125-100-400 150-125-250 150-125-315 150-125-400 200-150-250	1,75
200-150-315 200-150-400	2

## 7.4. STORAGE

The pump must be completely emptied of fluid before storage. If possible, avoid exposing the components of the pump to excessively damp environments.

## 7.5. CLEANING



The use of aggressive cleaning products such as caustic soda and nitric acid may cause burns to the skin.

Use rubber gloves during the cleaning process.



Always use protective goggles.

### 7.5.1. CIP process

If the pump is installed in a system with a CIP process, it is not necessary to dismantle the pump.  
If there is no automatic cleaning process, dismantle the pump as indicated in the *Assembly and Dismantling* section.

#### Cleaning solutions for CIP processes.

Only use clear water (chlorine-free) to mix with the cleaning agents:

**a) Alkaline solution:** 1% by weight of caustic soda (NaOH) at 70°C (150°F)

1 Kg NaOH + 100 l. of water = cleaning solution

2.2 l. NaOH at 33% + 100 l. of water = cleaning solution

**b) Acid solution:** 0.5% by weight of nitric acid (HNO<sub>3</sub>) at 70°C (150°F)

0.7 litres HNO<sub>3</sub> at 53% + 100 l. of water = cleaning



**Check the concentration of the cleaning solutions to avoid damaging the pump seals.**

To remove any remains of cleaning products, ALWAYS perform a final rinse with clean water on completion of the cleaning process.

### 7.5.2. Automatic SIP

The steam sterilisation process is applied to all equipment including the pump.



**DO NOT operate the equipment during the steam sterilisation process.**

The parts/materials will not suffer damage provided the instructions set out in this manual are followed.

**Cold liquid cannot be introduced until the pump temperature is below 60°C (140°F).**

The pump generates a substantial pressure loss through the sterilisation process; we recommend the use of a bypass circuit provided with a discharge valve to ensure that the steam / overheated water sterilises the entire circuit.

Maximum conditions during the steam or overheated water SIP process

- a) **Max. temperature:** 140°C / 284°F
- b) **Max. time:** 30 min.
- c) **Cooling:** Sterilised air or inert gas
- d) **Materials:** EPDM / PTFE (recommended)  
FPM / NBR (not recommended)



## 7.6. DISASSEMBLY / ASSEMBLY OF THE PUMP

### 7.6.1. Pump and impeller body

#### ⇒ Disassembly

Remove the hexagonal screws (52) and washers (53) fixing the housing (01) to the lantern (04). Remove the blind nut (45) and O-ring (80D), then take out the impeller (02).

#### ⇐ Assembly

Slide the impeller (02) over the shaft (05) until making contact with the spacer (17), attach the O-ring (80D) in the slot of the blind nut (45) and tighten the nut (45). Attach the housing (01) and fix it to the lantern (04) with hexagonal screws (52) and washers (53).

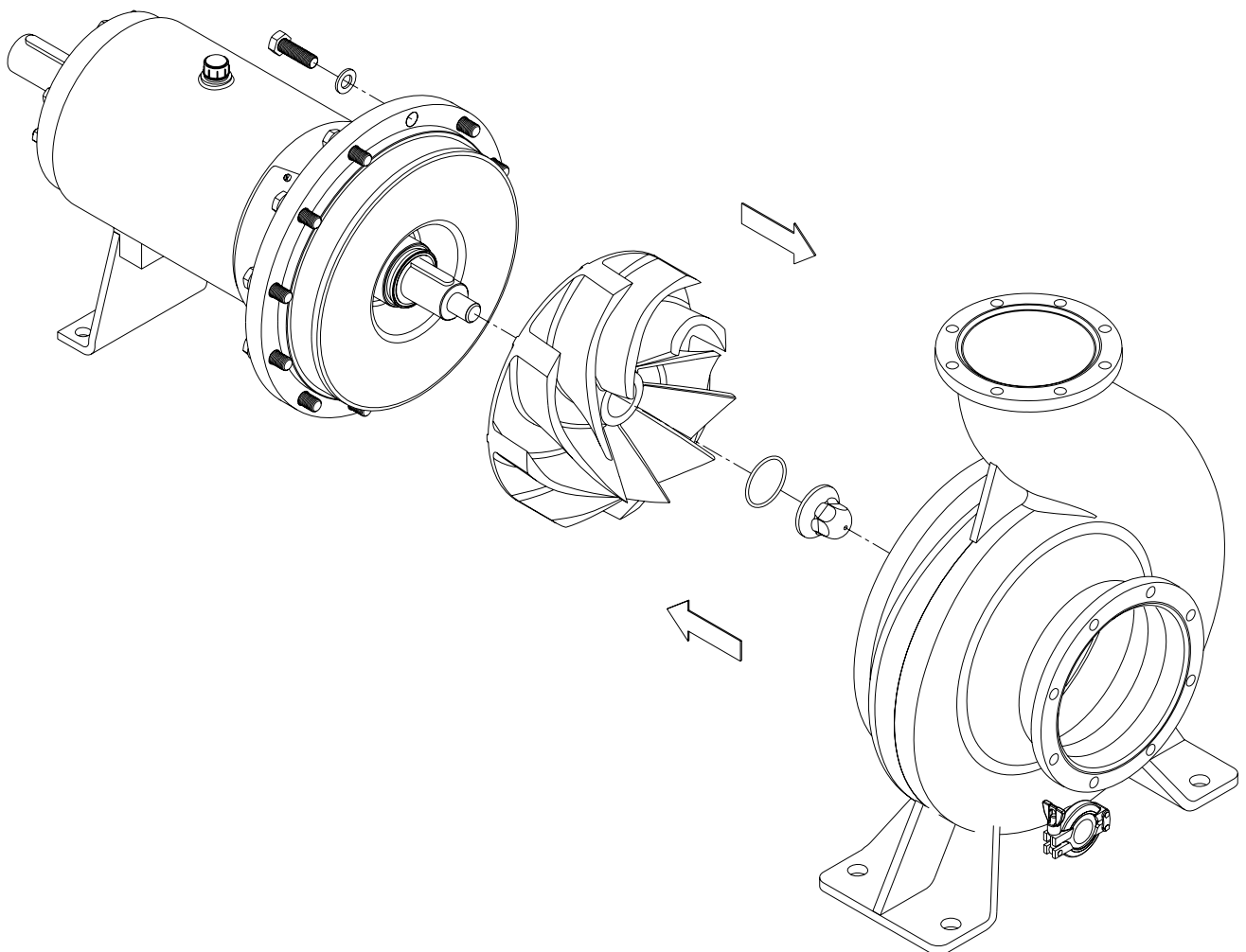

### 7.6.2. Single mechanical seal

#### ⇒ Disassembly

Remove the rotary part of the mechanical seal (08).

Remove the screws (52E) fixing the cover (03) with the lantern (04).

Remove the pump cover (03), the fixed part of the mechanical seal (08A) will remain housed inside the cap.

Remove the fixed part of the mechanical seal (08).

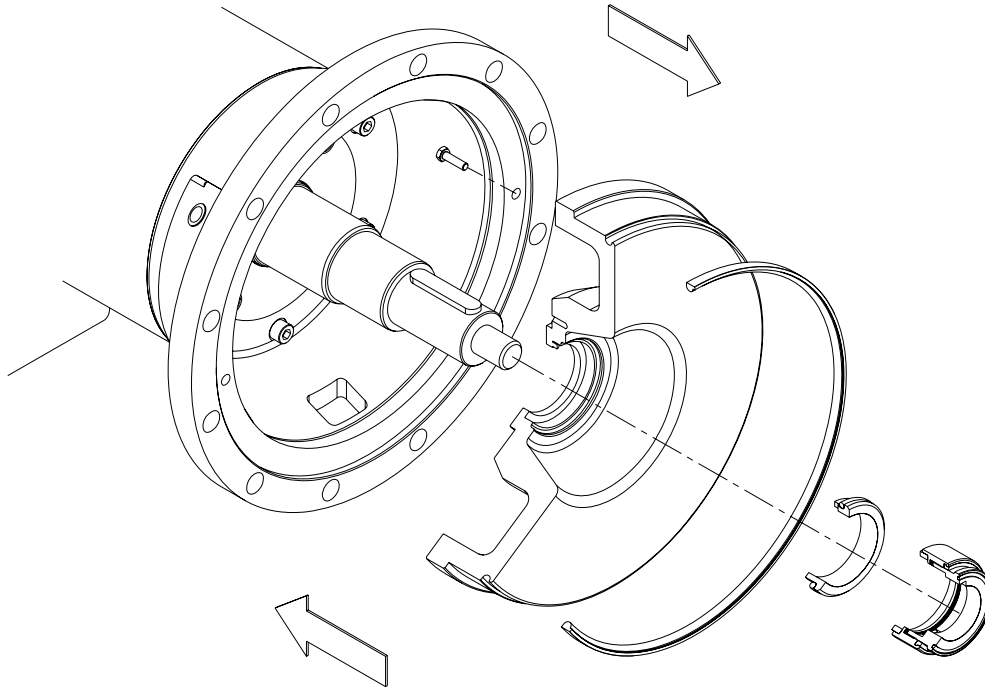

#### ← Assembly

Check the location of the shaft (05) in relation to the pump cover (03). See section 7.6.7. [Adjusting the pump shaft.](#)

Attach the pump cover (03) to the lantern (04) and fasten with the screws (52E).

Place the fixed part of the mechanical seal in the cover housing (03) taking the knob into account.

Check that assembly measure used is that which is described below:

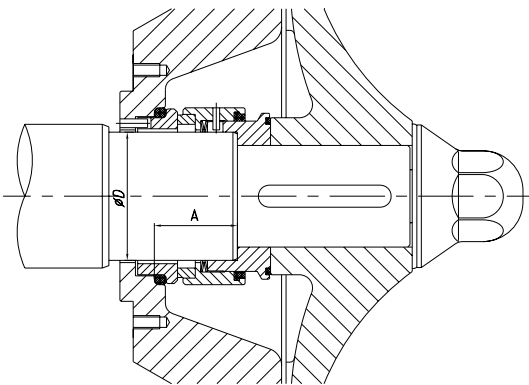

Slide the rotating part of the mechanical seal (08) over the shaft (05) till the end.

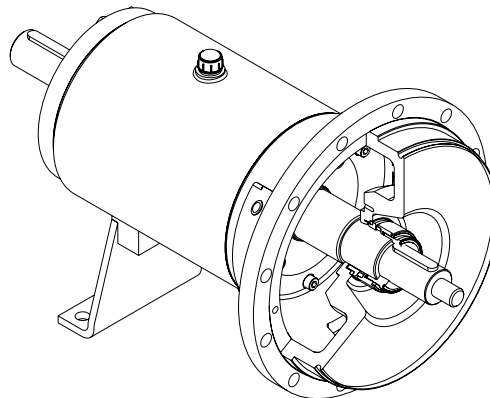

Ø D	A
51	34,5
58	37,5

**CAUTION!** When placing the new seal, assemble the parts and seals using soapy water to ensure that they slide over each other, including the stationary part and the rotary part of the shaft.

### 7.6.3. Flushed mechanical seal (bare shaft)

#### ⇒ Disassembly

Remove the rotary part of the mechanical seal (08).

Remove the screws (52E) fixing the cover (03) with the lantern (04).

Remove the pump cover (03) with the cap (10) and seal ring (30) still mounted. The fixed parts of the mechanical seals (08) and (08B) remain housed in the group.

Remove the fixed part of the mechanical seal (08).

Remove the screws (52C) and detach the seal ring (30), the fixed part of the external mechanical seal (08B), the cap (10), and the O-ring (80B).

Loosen the pins (55A) and extract the rotary part of the external mechanical seal (08A) with the sleeve (13).

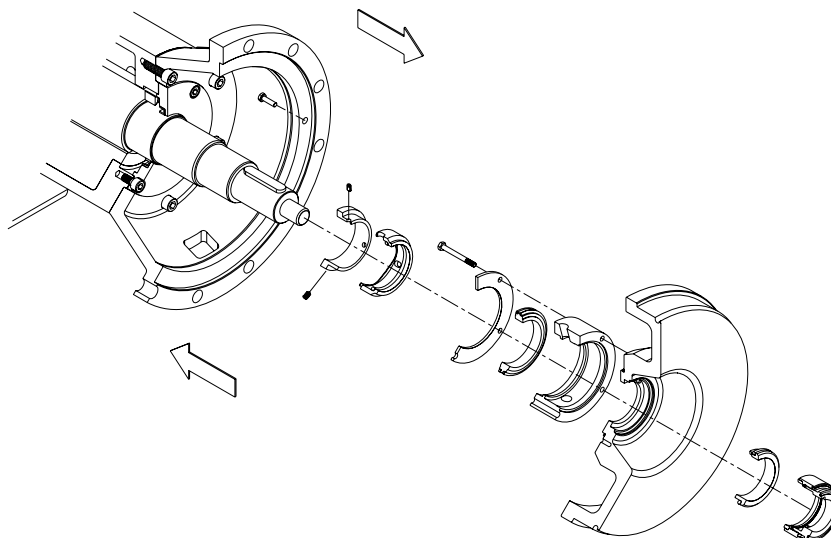

#### ⇐ Assembly

Check the location of the shaft (05) in relation to the pump cover (03). See section 7.6.7. [Adjusting the pump shaft.](#)

Attach the rotary part of the external mechanical seal (08A) with the gasket and spring on the sleeve (13) and fix the shaft using the pins (55A).

Place the O-ring (80B) over the pump cover alignment (03).

Place the cap (10), the fixed part of the external mechanical seal (08B), and the seal ring (30), and fasten it all onto the pump cover (03) using the screws (52C).

Carefully attach the entire assembly to the lantern (04) and fasten with the screws (52E). At the same time, both working surfaces of the external mechanical seal (08A, 08B) will make contact with each other.

In order to fit the internal mechanical seal, see the section on assembling the simple mechanical seal.

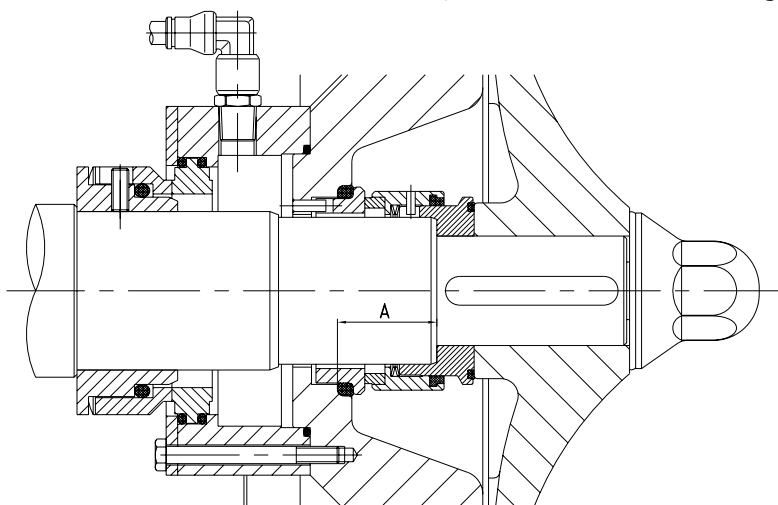

**CAUTION!** When placing the new seal, assemble the parts and seals using soapy water to ensure that these slide over each other, including the stationary part and the rotary part of the shaft.

#### 7.6.4. Flushed mechanical seal (close-coupled, size 160 and 180 motors)

##### ⇒ Disassembly

Remove the rotary part of the mechanical seal (08).

Remove the screws (52E) fixing the cover (03) with the lantern (04).

Remove the pump cover (03) with the cap (10) and seal ring (30) still mounted. The fixed parts of the mechanical seals (08) and (08B) remain housed in the group.

Remove the fixed part of the mechanical seal (08).

Remove the screws (52C) and detach the seal ring (30), the fixed part of the external mechanical seal (08B), the cap (10), and the O-ring (80B).

Remove the pins (55A) and extract the rotary part of the external mechanical seal (08A) with the gasket and spring.

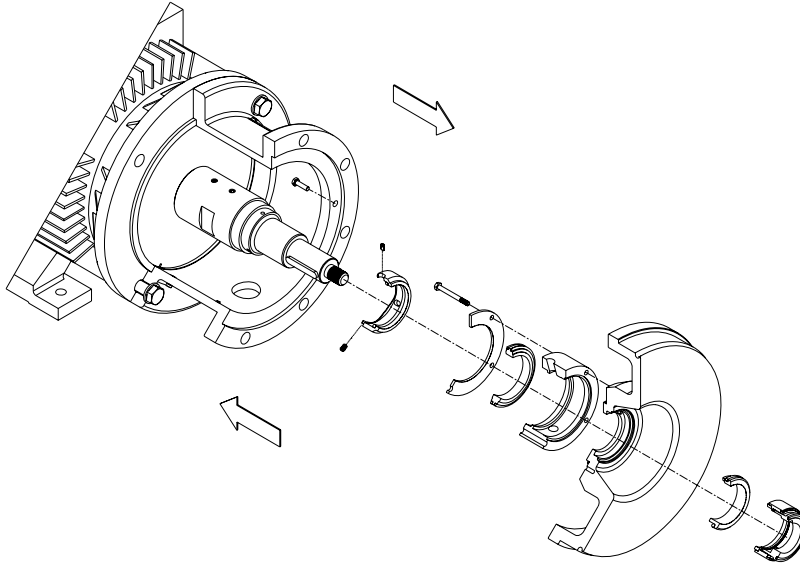

##### ⇐ Assembly

Check the location of the shaft (05A) in relation to the pump cover (03). See section 7.6.7. [Adjusting the pump shaft](#).

Attach the rotary part of the external mechanical seal (08A) with the gasket and spring on the shaft (05A) and fasten using the pins (55A).

Place the O-ring (80B) over the pump cover alignment (03).

Place the cap (10), the fixed part of the external mechanical seal (08B), and the seal ring (30), and fasten it all onto the pump cover (03) using the screws (52C).

Carefully attach the entire assembly to the lantern (04) and fasten with the screws (52E). At the same time, both working surfaces of the external mechanical seal (08A, 08B) will make contact with each other.

In order to fit the internal mechanical seal, see the section on assembling the simple mechanical seal.

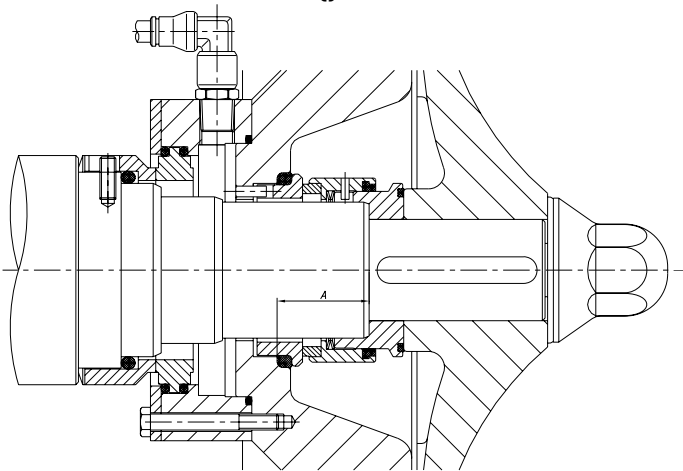

**CAUTION!** When placing the new seal, assemble the parts and seals using soapy water to ensure that these slide over each other, including the stationary part and the rotary part of the shaft.

### 7.6.5. Flushed mechanical seal (close-coupled, size 200 motors)

#### ⇒ Disassembly

Remove the rotary part of the mechanical seal (08).

Remove the screws (52E) fixing the cover (03) with the lantern (04).

Remove the pump cover (03) with the cap (10), back-cover (10A), and seal ring (30) still mounted. The fixed parts of the mechanical seals (08) and (08B) remain housed in the group.

Remove the fixed part of the mechanical seal (08).

Remove the screws (52C) and detach the seal ring (30), the fixed part of the external mechanical seal (08B), the cap (10), and the O-ring (80B).

Remove the screws (51) and detach the back-cover (10A) and the O-ring (80B).

Loosen the pins (55A) and extract the rotary part of the external mechanical seal (08A) with the sleeve (13).

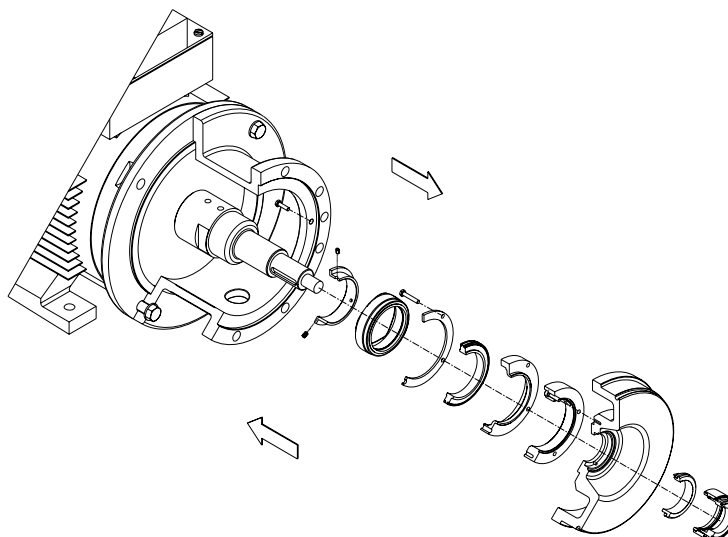

#### ⇐ Assembly

Check the location of the shaft (05A) in relation to the pump cover (03). See section 7.6.7. [Adjusting the pump shaft.](#)

Attach the sleeve (13) until making contact with the shaft (05A).

Attach the rotary part of the external mechanical seal (08A) with the gasket and spring on the sleeve (13) and fix the shaft using the pins (55A).

Attach the O-ring (80B) with the back-cover (10A) on the pump cover alignment (03) and fasten the screws (51).

Place the O-ring (80B) on the cap alignment (10) and attach the fixed part of the external mechanical seal (08B), the seal ring (30), and fasten it all onto the back-cover (10<sup>a</sup>) using the screw (52C).

Carefully attach the entire assembly to the lantern (04) and fasten with the screws (52E). At the same time, both working surfaces of the external mechanical seal (08A, 08B) will make contact with each other.

In order to fit the internal mechanical seal, see the section on assembling the simple mechanical seal.

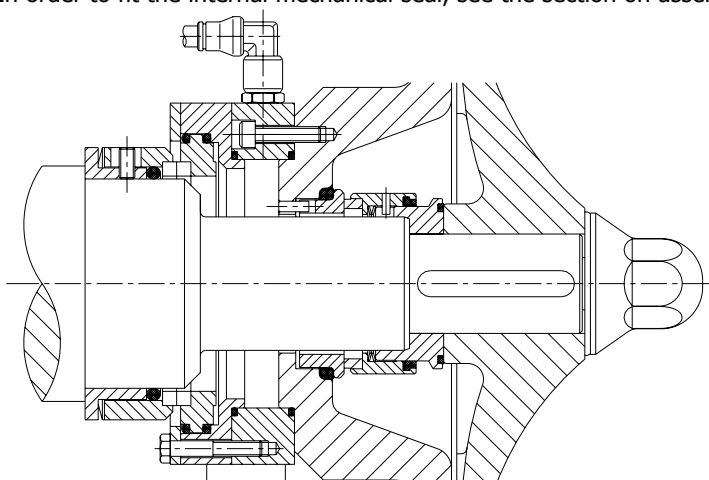

**CAUTION!** When placing the new seal, assemble the parts and seals using soapy water to ensure that these slide over each other, including the stationary part and the rotary part of the shaft.

### 7.6.6. Double mechanical seal (bare shaft)

#### ⇒ Disassembly

Remove the spacer (17) together with the O-rings (80D).

Remove the screws (52C) leaving the external cover loose (10B) with the fixed part of the external mechanical seal (08A) and the O-ring (80B).

Remove the screws (52E) fixing the pump cover (03A) with the lantern (04).

Remove the pump cover (03A) with the double seal cap (10A) and the internal cover (10C) still mounted. The fixed part of the internal mechanical seal (08) remains housed in the assembly.

Remove the screws (52D) and detach the double seal cap (10A) with the O-ring (80B).

Remove the internal cover (10C) with the O-ring (80C) and the fixed part of the internal mechanical seal (08).

Loosen the pins of the rotary parts of the mechanical seals (08) and (08A), and remove them from the shaft (05A).

Remove the external cover (10B) with the fixed part of the external mechanical seal (08A) and the O-ring (80B).

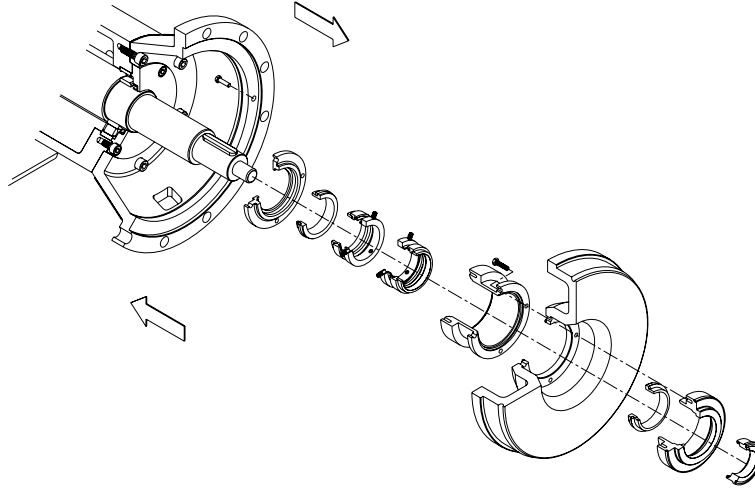

#### ⇐ Assembly

Check the location of the shaft (05A) in relation to the pump cover (03A). See section 7.6.7. [Adjusting the pump shaft.](#)

Place the fixed part of the external mechanical seal (08A) in the housing of the external cover (10B), taking the pivot into account, and place the O-ring (80B) over the cover alignment.

Attach the whole assembly and leave it loose at the end of the shaft (05A).

Slide the rotary part of the external mechanical seal (08A) onto the shaft (05A). Fasten it according to dimension A in the table. Attach the rotary part of the internal mechanical seal (08) as far as the rotary part of the external mechanical seal and fasten it.

Place the fixed part of the internal mechanical seal (08) in the housing of the internal cover (10C), taking the pivot into account, and place the O-ring (80B) in the cover groove.

Attach the whole assembly to the pump cover housing (03A) and align the fixing bores.

Attach the O-ring (80B) with the double seal cap (10A) on the internal cover alignment (10C) and fasten the screws (52D).

Carefully attach the entire assembly to the lantern (04) and fasten with the screws (52E). At the same time, both working surfaces of the internal mechanical seal (08) will make contact with each other.

Carefully place the external cover (10B) with the fixed part of the external mechanical seal (08A) and the O-ring (80B) on the double seal cap alignment (10A) and fasten with the screws (52C). At the same time, both working surfaces of the external mechanical seal (08A) will make contact with each other.

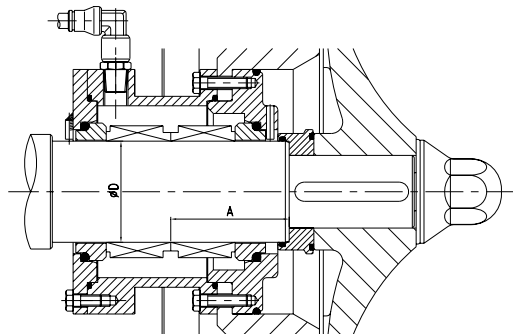

Seal diameter	A
53	62,5
60	68

**CAUTION!** When placing the new seal, assemble the parts and seals using soapy water to ensure that these slide over each other, including the stationary part and the rotary part of the shaft.

### 7.6.7. Adjusting the pump shaft

Check that the shaft (05) assembly dimension in relation to the pump cover (03) is as indicated below:

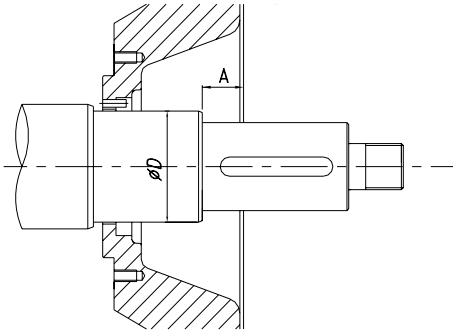

Pump type	Ø D	A
250	51	16
315/400	51	8
315/400	58	20

If not, adjust the dimension until it is as indicated below.

- For close-coupled type models, loosen the setbolts (55) and slide the shaft (05) until the dimension has been adjusted. Finally, firmly tighten the setbolts.
- For bare shaft type models, loosen the hexagonal screws (52A) and nuts (54), and adjust the dimension using the pins (55). Once adjusted, tighten the nuts (54) and screws (52A).

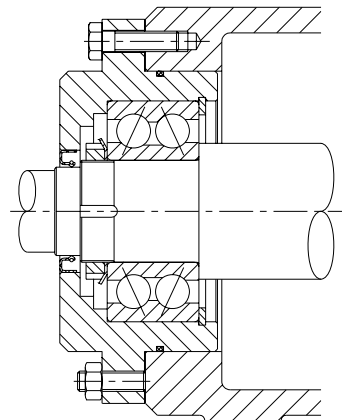
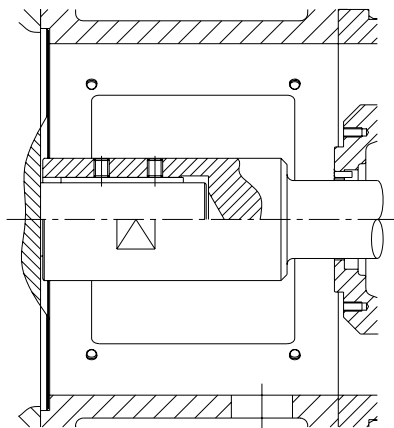

### 7.6.8. Lantern and motor (close-coupled)

#### ⇨ Disassembly

Remove the hexagonal screws (52A), nuts (54), and washers (53) and (53A), to be able to take out the lantern (04).

Loosen the setbolts (55) and take out the shaft (05).

Remove the screws (52B), nuts (54A), and washers (53B). This will make it possible to remove the motor (93) from the baseplate (38).

#### ⇨ Assembly

Place the motor (93) onto the baseplate (38) and attach with screws (52B), nuts (54A), and washers (53B).

Slide the shaft (05) over the shaft of the motor (93) until coming to a stop, and fasten with the setbolts (55).

Place the lantern (04) in its assembly position and fix it to the motor (93) with hexagonal screws (52A), nuts (54), and washers (53) and (53A).

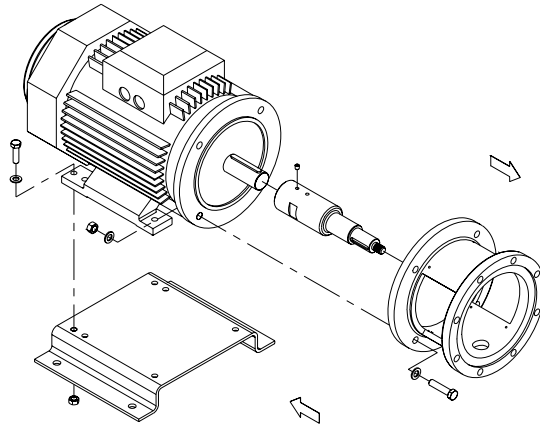



# 8. Technical Specifications

## 8.1. TECHNICAL SPECIFICATIONS

	50Hz	60Hz
Maximum flow (1450 min <sup>-1</sup> ).....	1000 m <sup>3</sup> /h	1000 m <sup>3</sup> /h
Maximum differential pressure .....	6 bar (87 PSI)	9 bar (131 PSI)
Maximum suction pressure .....	14 bar (203 PSI)	11 bar (160 PSI)
Maximum working pressure .....	20 bar (290 PSI)	20 bar (290 PSI)
Operating temperature .....	-10°C to +140°C (EPDM) 14°F to 284°F (EPDM)	-10°C to +140°C (EPDM) 14°F to 284°F (EPDM)
Maximum speed .....	1450 min <sup>-1</sup>	1750 min <sup>-1</sup>
Suction / delivery connections .....	DIN 11864-2 (standard)	DIN 11864-2 (standard)



Use special protection when the noise level in the operation area exceeds 85 dB(A).

### Materials

Parts in contact with product.....	AISI 316L
Other parts in stainless steel. ....	AISI 304
Gaskets in contact with product .....	EPDM (standard)
Other materials for optional gaskets .....	Check with the supplier
Surface finish .....	Standard polishing

### Mechanical seal

Type of seal .....	Single internal seal
--------------------	----------------------

### Flushed mechanical seal

Maximum pressure.....	1 bar (14.5 PSI)
Flow rate.....	6-10 l/min

### Double mechanical seal

Operating pressure .....	1.5~2 bar (22~29 PSI) above the operating pressure of the pump
--------------------------	--

Mechanical seal materials	Type of mechanical seal			
	Single internal	Flushed	Double (atmosphere side)	Double (product side)
Stationary part	Graphite			Silicon carbide
Rotary part	Silicon carbide			

## 8.2. WEIGHTS

Pump type - Bare shaft -	Weight [Kg]	Weight [lbs]
125-100-250	113	249
125-100-315	127	280
125-100-400	135	298
150-125-250	118	260
150-125-315	133	293
150-125-400	149	329
200-150-250	124	273
200-150-315	194	428
200-150-400	210	463

Pump type - close-coupled	MOTOR	Weight [Kg]	Weight [lbs]
125-100-250	160	204	449
	180	239	526
150-125-250	160	210	462
	180	256	563
200-150-250	180	263	579
	200	360	792

### 8.3. DIN-FOOD DIMENSIONS (BARE SHAFT)

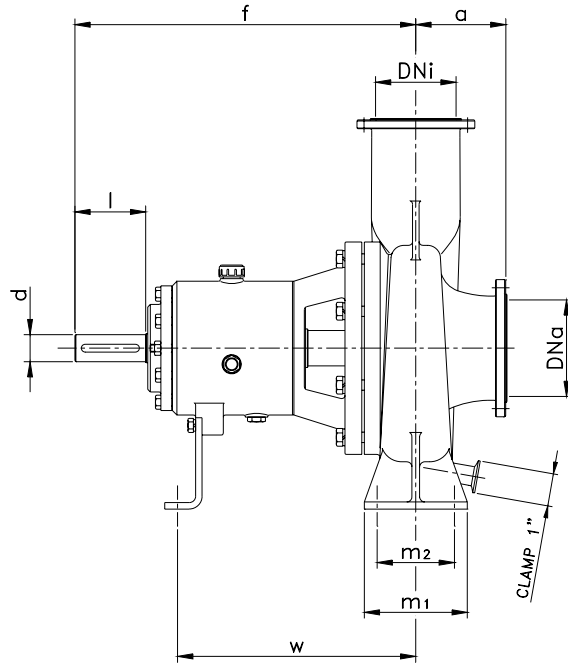
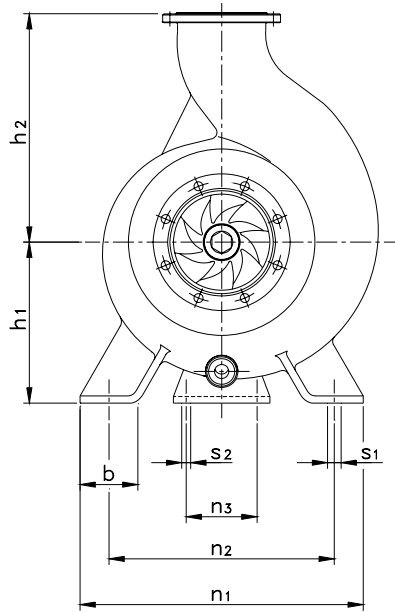

Flange dimensions DIN 11864-2-A

DN	D	k	d4	d2
100	159	137	117	8 x Ø11
125	183	161	142	
150	213	188	168	8 x Ø14
200	263	238	218	

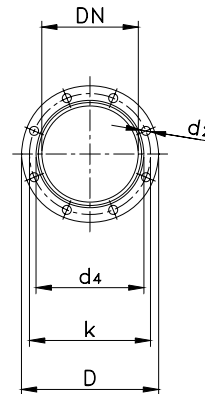

-{}-

PUMP TYPE	DNa	DNi	d	l	a	f	h <sub>1</sub>	h <sub>2</sub>	b	m <sub>1</sub>	m <sub>2</sub>	n <sub>1</sub>	n <sub>2</sub>	n <sub>3</sub>	s <sub>1</sub>	s <sub>2</sub>	w	
125-100-250	125	100	42	110	121	522	250	316	90	160	120	440	350	110	18	14	363	
125-100-315					510	280	352	490				400	350					
125-100-400					130	330	402	100				200	150				550	450
150-125-250	150	125	42	110	128	530	250	355	90	160	120	440	350	110	18	14	370	
150-125-315					137	518	280	372				490	400				23	358
150-125-400					140	330	422	100				200	150				550	450
200-150-250	200	150	42	110	142	537	250	375	90	200	150	440	350	110	23	14	378	
200-150-315			48		153	670	280	402				490	400				140	500
200-150-400			667		330	452	100	200				150	550				450	18

### 8.4. DIN-FOOD DIMENSIONS (BARE SHAFT, WITH BASEPLATE)

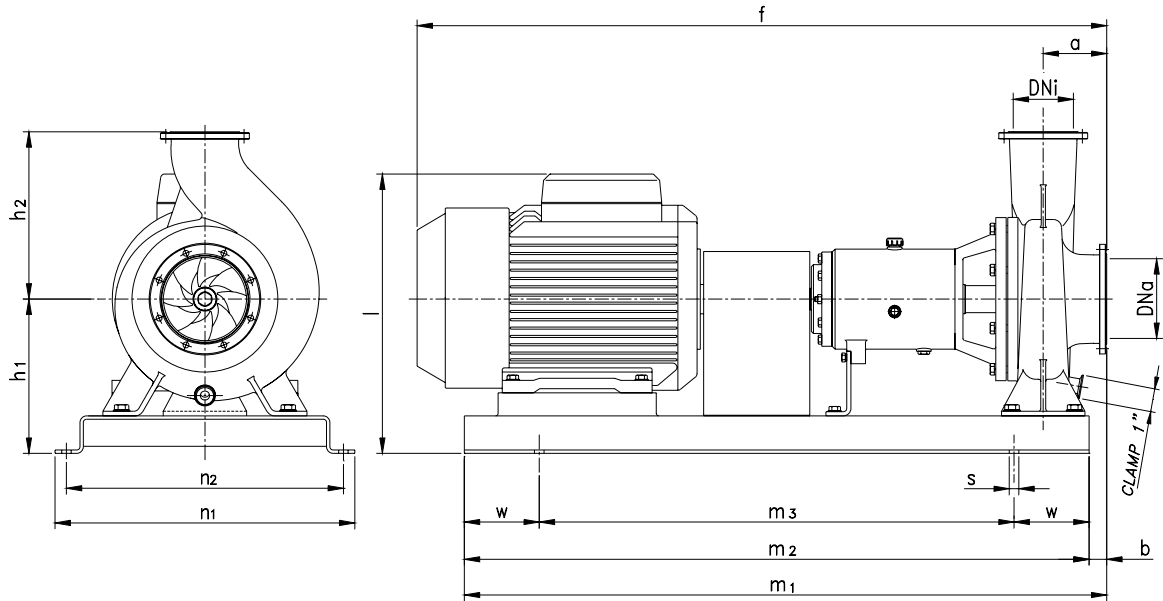

PUMP TYPE	MOTOR	DNa	DNi	a	f	h <sub>1</sub>	h <sub>2</sub>	b	l	m <sub>1</sub>	m <sub>2</sub>	m <sub>3</sub>	n <sub>1</sub>	n <sub>2</sub>	s	w															
125-100-250	160 M	125	100	121	1250	340	316	35	550	1335	1300	1020	620	565	23	140															
	160 L				1290																										
	180 M				1330																										
150-125-250	160 M	150	125	128	1265		375	40	550	1340							1335	1300	1020	620	565	23	140								
	160 L				1305																										
	180 M				1345																										
	180 L				1365																										
200-150-250	160 L	200	150	142	1330		372	35	550	1335							1350	1300	1020	620	565	23	140								
	180 M				1365																										
	180 L				1385																										
	200 L				1405																										
125-100-315	160 M	125	100	121	1240		370	352	35	580							1385	1350	990	720	665	23	140								
	160 L				1280																										
	180 M				1315																										
	180 L				1335																										
	200 L				1355																										
150-125-315	160 L	150	125	137	1305	372		30	580	1380	1350	990	720	665	23	140															
	180 M				1340																										
	180 L				1360																										
	200 L				1380																										
	225				1490																										
200-150-315	160 L	200	150	153	1470	402		45	580	1395							1545							1500	1140	720	665	23	140		
	180 M				1510																										
	200 L				1550																										
	225				1660																										
	250 M				1725																										
	280 S				1820																										
125-100-400	200 L	125	100	130	1365	420	20	700	1370	1520								1500	1140	720	665	23	140								
	225				1475																										
	250 M				1540																										
	280 S				1705																										
150-125-400	225	150	125	140	1495		422	30	720		1380	1530	1500	1140	720	665														23	140
	250 M				1560																										
	280 S				1725																										
	280 M				1785																										
	315 S				1790																										
200-150-400	225	200	150	153	1655		452	35	720		1545						1835							1800	1400	820	765	23	140		
	250 M				1720																										
	280 S				1885																										
	280 M				1945																										
	315 S				1950																										
	315 M				2090																										
	315 L				2120																										

### 8.5. DIN-FOOD DIMENSIONS (CLOSE-COUPLED)

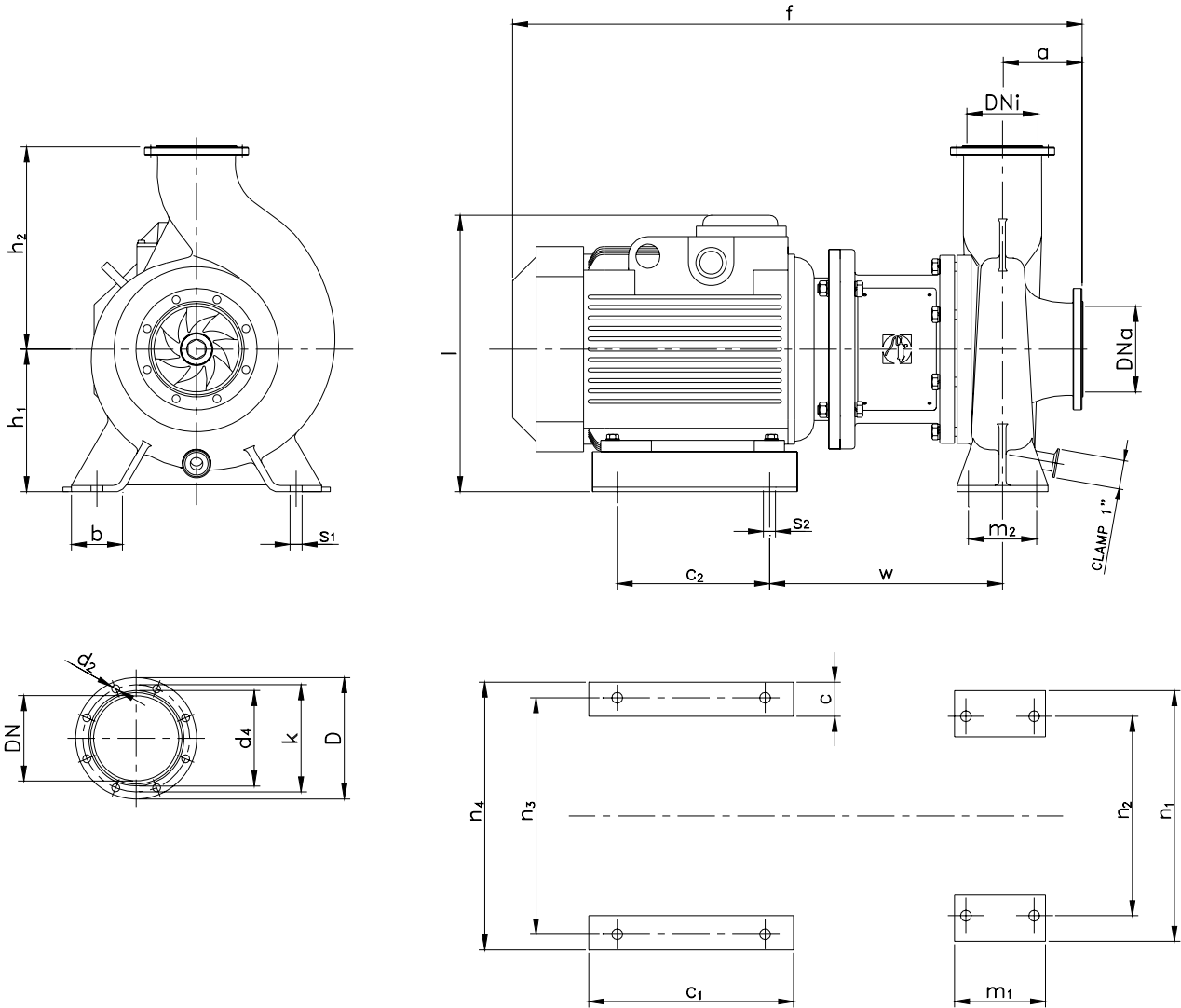

Flange dimensions DIN 11864-2-A

DN	D	k	$d_4$	$d_2$
100	159	137	117	8 x $\varnothing 11$
125	183	161	142	
150	213	188	168	8 x $\varnothing 14$
200	263	238	218	

PUMP TYPE	MOTOR	$DN_a$	$DN_i$	a	f	$h_1$	$h_2$	b	c	$c_1$	$c_2$	l	$m_1$	$m_2$	$n_1$	$n_2$	$n_3$	$n_4$	$s_1$	$s_2$	w
125-100-250	160	125	100	121	850	250	316	90	68	360	260	460	160	120	440	350	415	470	18	18	342
	180			930																	367
150-125-250	160	150	125	128	865	250	355	90	68	360	260	460	160	120	440	350	415	470	18	18	349
	180			945																	374
200-150-250	180	200	150	142	965	250	375	68	88	400	305	585	200	150	600	545	545	600	23	23	381
	200			1005																	340

### 8.6. DIN-FOOD DIMENSIONS (SHROUDED, CLOSE-COUPLED)

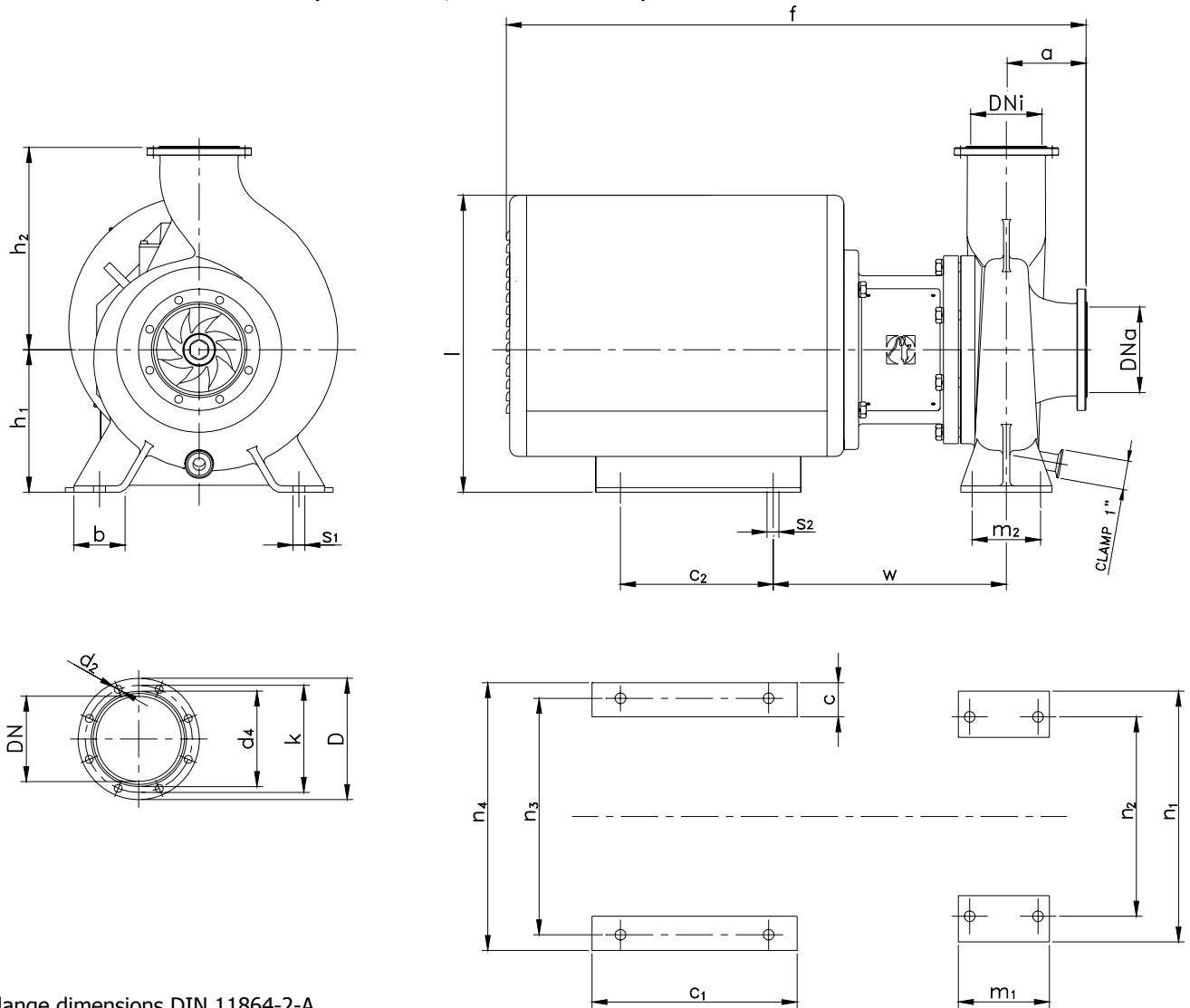

Flange dimensions DIN 11864-2-A

DN	D	k	d <sub>4</sub>	d <sub>2</sub>
100	159	137	117	8 x Ø11
125	183	161	142	
150	213	188	168	8 x Ø14
200	263	238	218	

125-100-250	160	125	100	121	960	250	316	90	68	360	260	525	160	120	440	350	415	470	18	18	344
	180																				369
150-125-250	160	150	125	128	975	250	355	90	68	360	260	525	160	120	440	350	415	470	18	18	351
	180																				376
200-150-250	180	200	150	142	995	340	375	68	88	400	305	690	200	150	600	545	545	600	23	23	383
	200				1105								210								23

8.7. DIN-FOOD PUMP (BARE SHAFT)

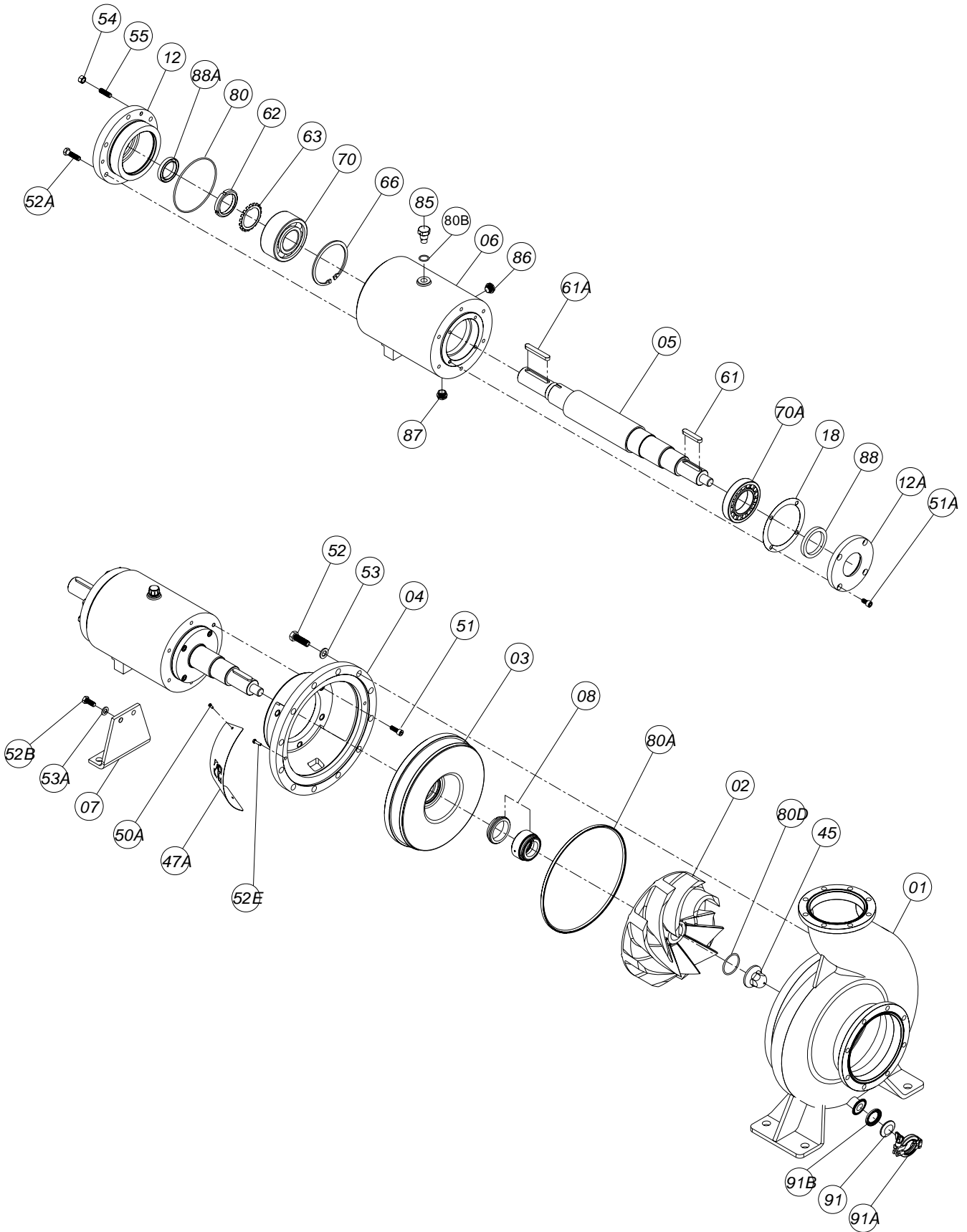

### 8.8. DIN-FOOD PUMP (CLOSE-COUPLED)

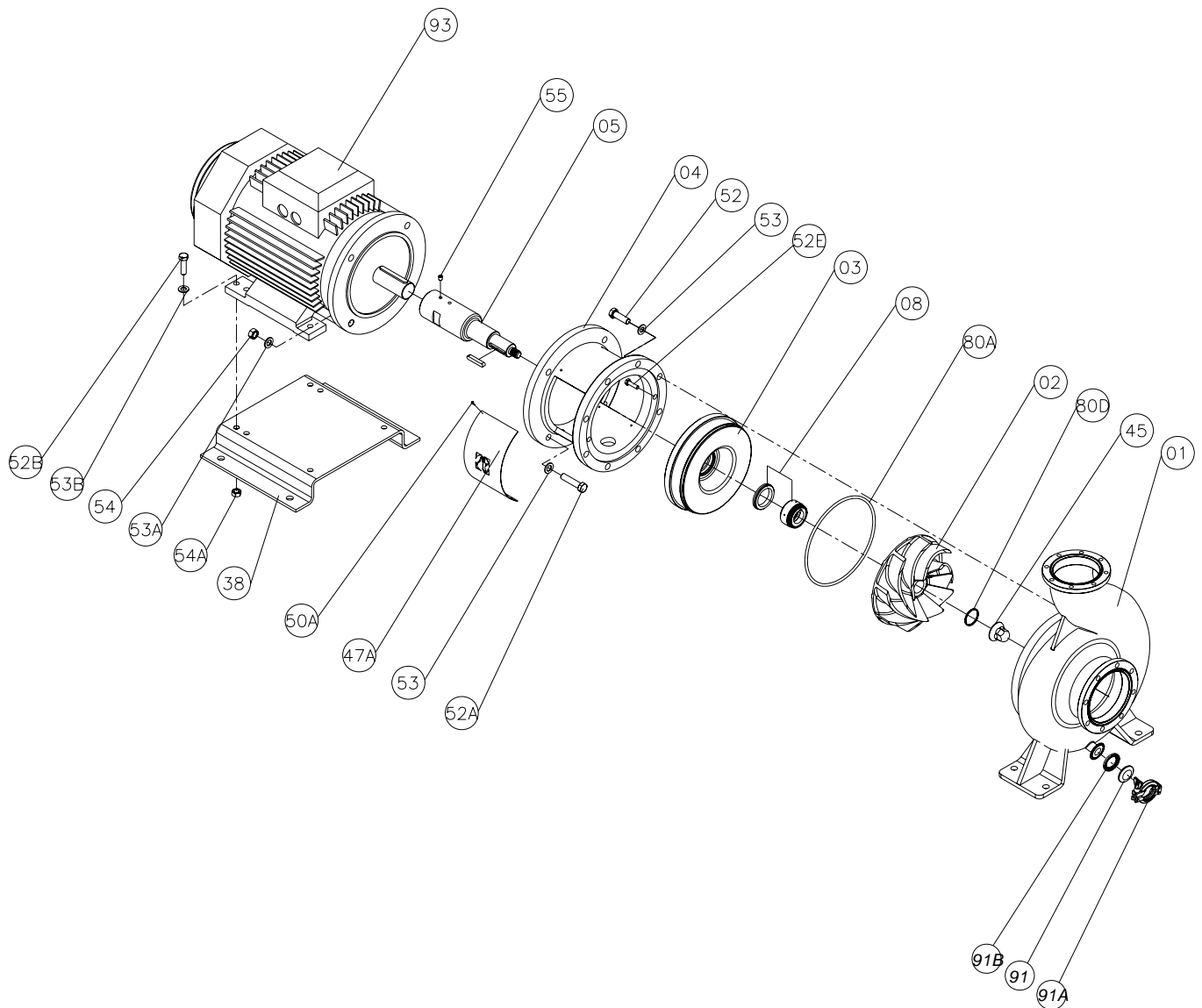

8.9. DIN-FOOD PUMP (BARE SHAFT). CROSS-SECTION.

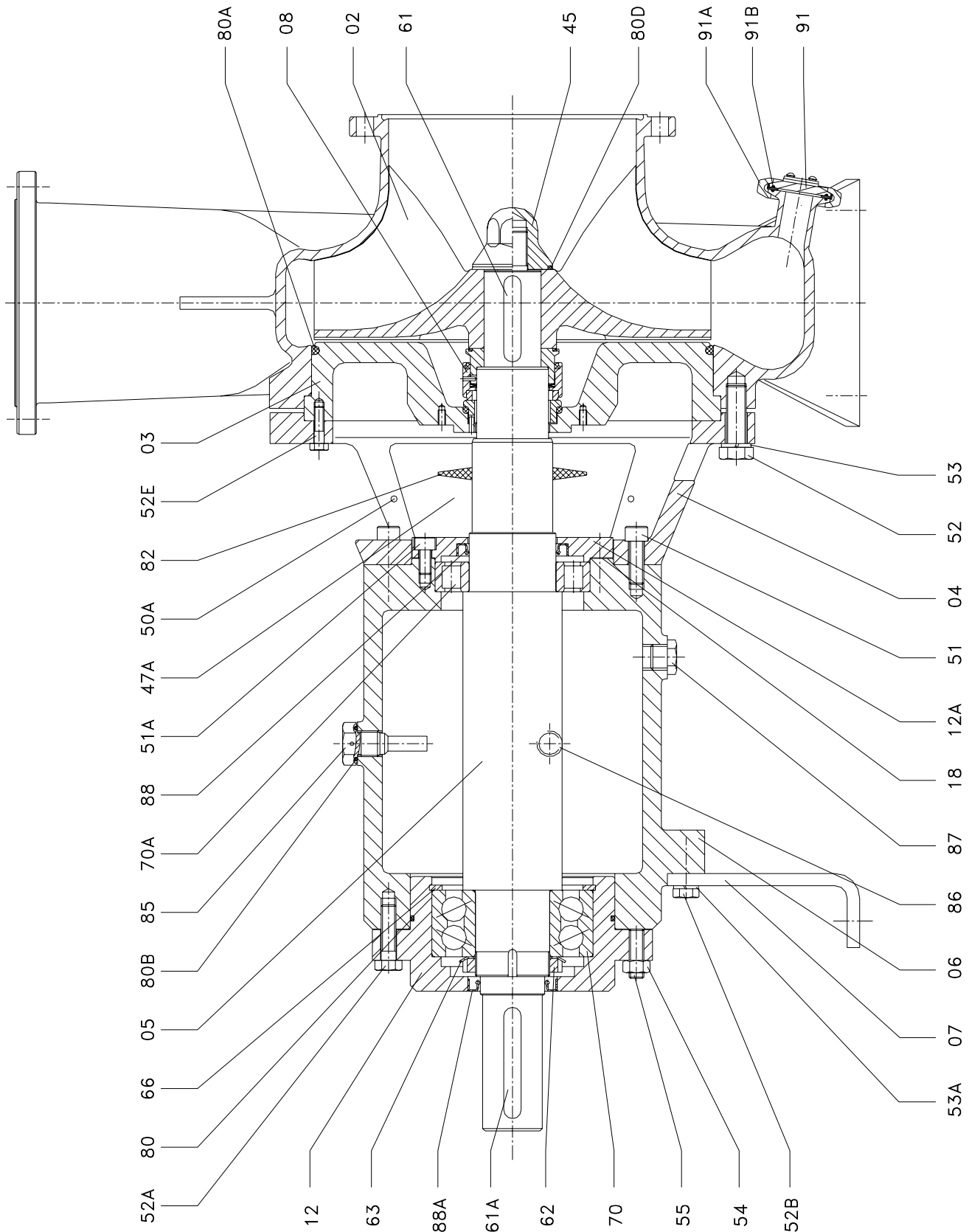



**8.10. DIN-FOOD (BARE SHAFT). PARTS LIST**

Position	Description	Quantity	Material
01	Pump casing	1	AISI 316L
02	Impeller	1	AISI 316L
03	Pump cover	1	AISI 316L
04	Lantern	1	GG-15
05	Shaft	1	AISI 316L
06	Bearings support	1	GG-15
07	Rear leg	1	GG-15
08	Mechanical seal	1	-
12	Rear bearings cover	1	F-114
12A	Front bearings cover	1	F-114
18	Front cover gasket	1	Gasket cardboard
45	Cap nut	1	AISI 316L
47	Lantern protector	2	AISI 304
50A	Screw	4	A2
51	Allen screw	6	8.8
51A	Allen screw	4	8.8
52	Hexagonal screw	12	A2
52A	Hexagonal screw	6	8.8
52B	Hexagonal screw	2	A2
52E	Hexagonal screw	2	A2
53	Grower washer	12	A2
53A	Grower washer	2	A2
54	Hexagonal nut	3	8.8
55	Pin	3	8.8
61	Key	1	A2
61A	Key	1	F-114
62	Self-locking nut	1	Steel
63	Safety washer	1	Steel
66	Elastic ring	1	Steel
70	Angular double-contact bearings	1	Steel
70A	Cylindrical roller bearings	1	Steel
80	O-ring	1	EPDM
80 <sup>a</sup>	O-ring	1	EPDM
80B	O-ring	1	NBR
80D	O-ring	1	EPDM
82	Splash ring	1	EPDM
85	Oil plug	1	AISI 303
86	Sight-glass	1	Plastic
87	Drain plug	1	Plastic
88	Lock	1	NBR
88A	Lock	1	NBR
91	Flange	1	AISI 304
91A	Bushing	1	AISI 316L
91B	O-ring	1	EPDM

8.11. DIN-FOOD PUMP (CLOSE-COUPLED). CROSS-SECTION

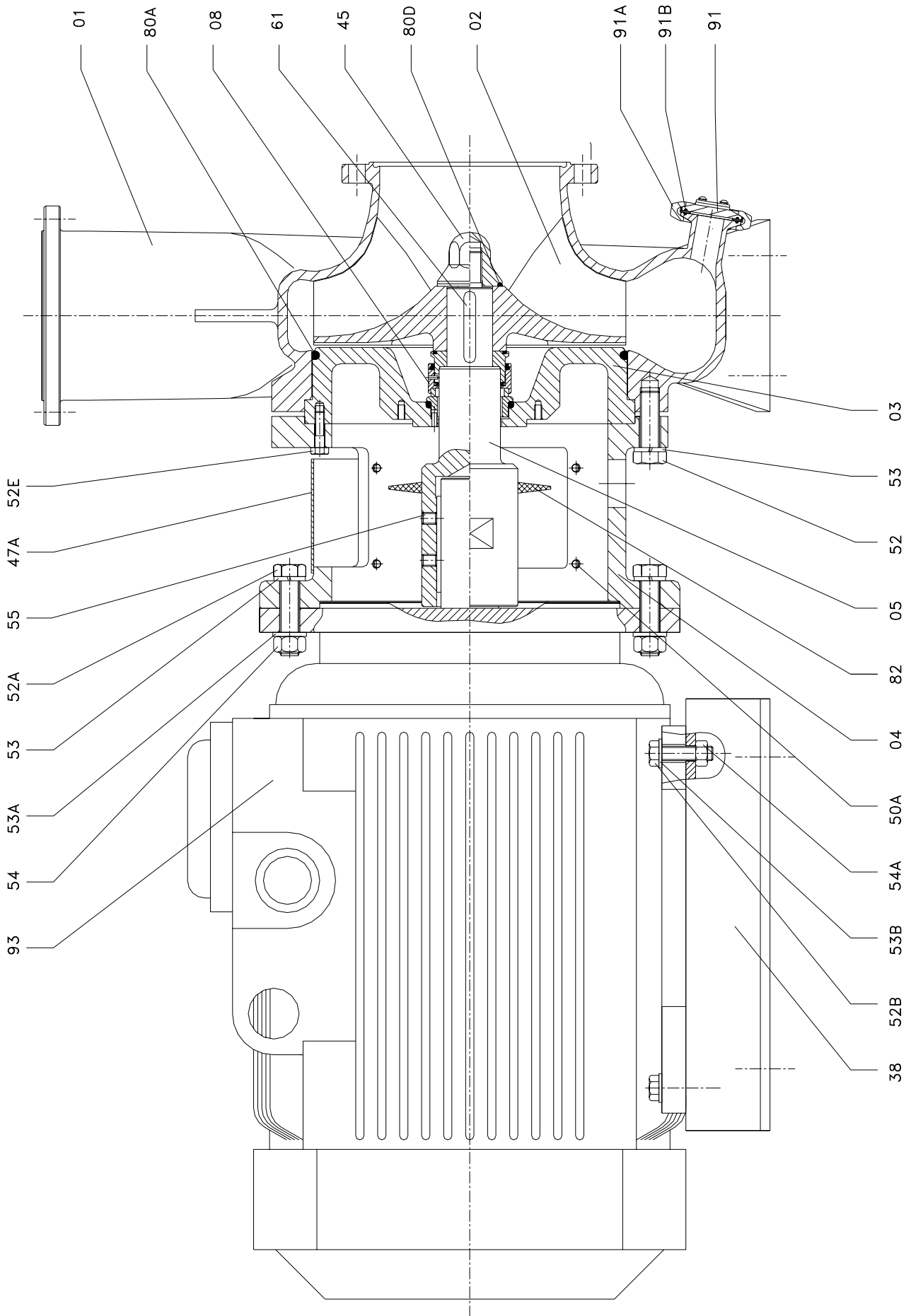

**8.12. DIN-FOOD (CLOSE-COUPLED). PARTS LIST**

Position	Description	Quantity	Material
01	Casing	1	AISI 316L
02	Impeller	1	AISI 316L
03	Pump cover	1	AISI 316L
04	Lantern	1	GG-15
05	Shaft	1	AISI 316L
08	Mechanical seal	1	-
38	Bedplate	1	AISI 304
45	Cap nut	1	AISI 316L
47A	Lantern protector	2	AISI 304
50A	Screw	8	A2
52	Hexagonal screw	8	A2
52A	Hexagonal screw	4	A2
52B	Hexagonal screw	4	A2
52E	Hexagonal screw	2	A2
53	Grower washer	12	A2
53A	Flat washer	4	A2
53B	Flat washer	4	A2
54	Hexagonal nut	4	A2
54A	Hexagonal nut	4	A2
55	Pin	2	A2
61	Key	1	A2
80A	O-ring	1	EPDM
80D	O-ring	1	EPDM
82	Splash ring	1	EPDM
91	Flange	1	AISI 304
91A	cec bushing	1	AISI 316L
91B	O-ring	1	EPDM
93	Motor	1	-

### 8.13. DIN-FOOD. FLUSHED MECHANICAL SEAL (BARE SHAFT)

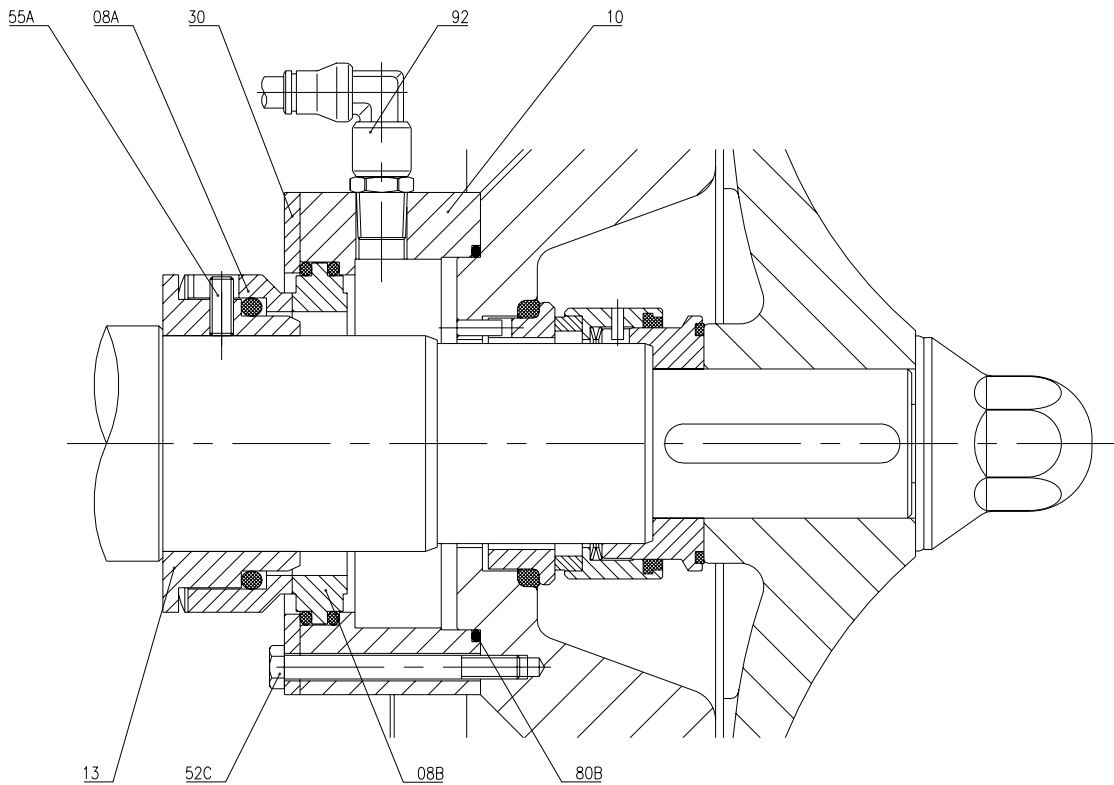

Position	Quantity	Description	Material
08A	1	Mechanical seal - rotary part -	-
08B	1	Mechanical seal - stationary part	-
10	1	Cap	AISI 316L
13	1	Cooled seal sleeve	AISI 316L
30	1	Cooled seal ring	AISI 316L
52C	4	Hexagonal screw	A2
55A	3	Pin	A2
80B	1	O-ring	EPDM
92	2	Connection elbow	AISI 316

### 8.14. DIN-FOOD. FLUSHED MECHANICAL SEAL (CLOSE-COUPLED, SIZE 160 AND 180 MOTORS)

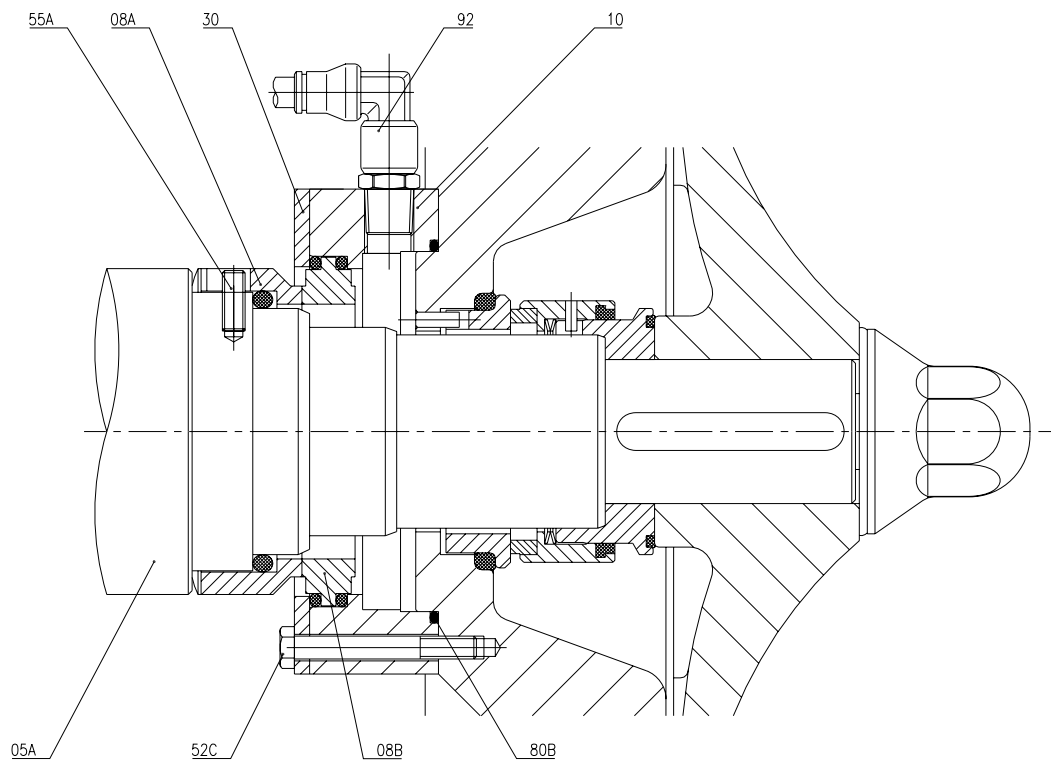

Position	Quantity	Description	Material
05A	1	Shaft	AISI 316L
08A	1	Mechanical seal - rotary part -	-
08B	1	Mechanical seal – stationary part	-
10	1	Cap	AISI 316L
30	1	Cooled seal ring	AISI 316L
52C	4	Hexagonal screw	A2
55A	3	Pin	A2
80B	1	O-ring	EPDM
92	2	Connection elbow	AISI 316

### 8.15. DIN-FOOD. FLUSHED MECHANICAL SEAL (CLOSE-COUPLED, SIZE 200 MOTORS)

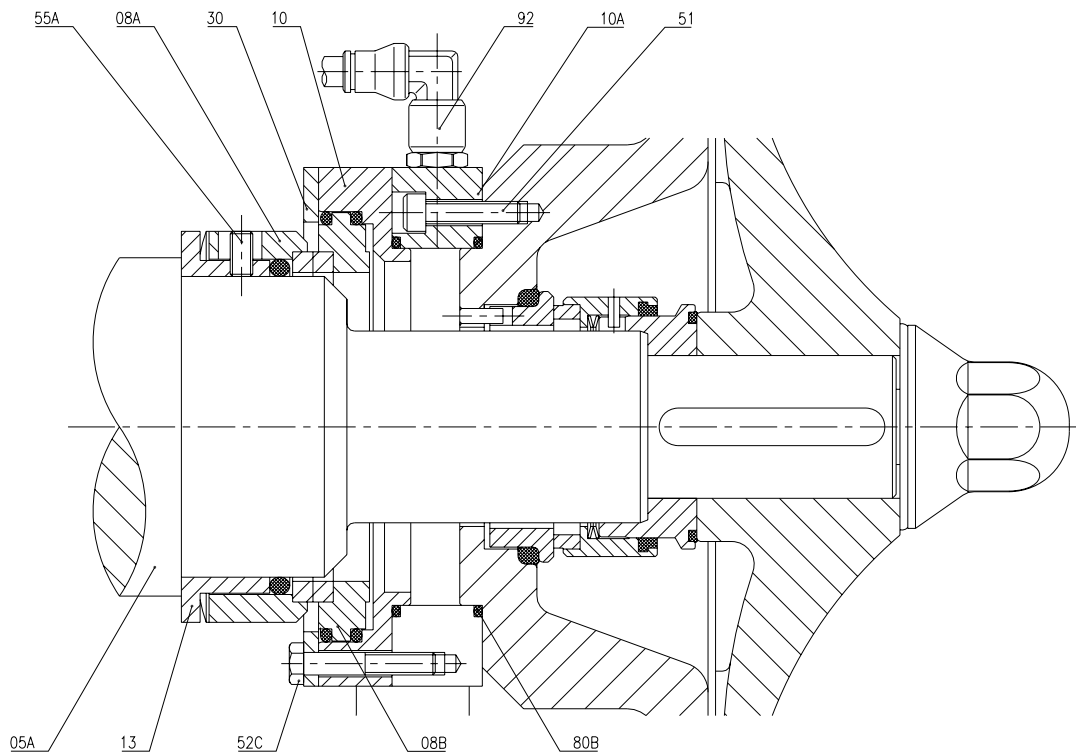

Position	Quantity	Description	Material
05A	1	Shaft	AISI 316L
08A	1	Mechanical seal - rotary part -	-
08B	1	Mechanical seal – stationary part	-
10	1	Cap	AISI 316L
13	1	Cooled seal sleeve	AISI 316L
30	1	Cooled seal ring	AISI 316L
51	2	Allen screw	A2
52C	4	Hexagonal screw	A2
55A	3	Pin	A2
80B	1	O-ring	EPDM
92	2	Connection elbow	AISI 316

### 8.16. DIN-FOOD DOUBLE MECHANICAL SEAL (BARE SHAFT)

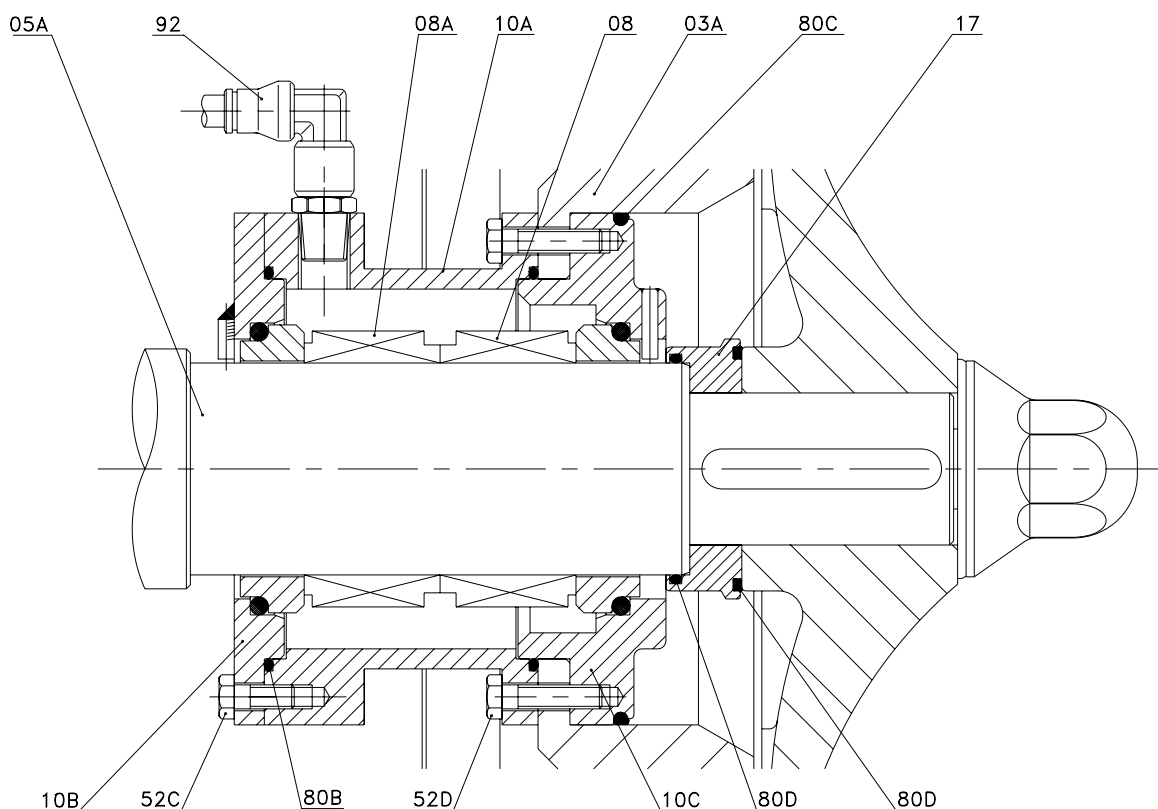

Position	Quantity	Description	Material
03A	1	Pump cover	AISI 316L
05A	1	Shaft	AISI 316L
08	1	Internal mechanical seal	-
08A	1	External mechanical seal	-
10A	1	Double seal cap	AISI 316L
10B	1	External cover	AISI 316L
10C	1	Internal cover	AISI 316L
17	1	Spacer	AISI 316L
52C	4	Hexagonal screw	A2
52D	4	Hexagonal screw	A2
80B	2	O-ring	EPDM
80C	1	O-ring	EPDM
80D	2	O-ring	EPDM
92	2	Connection elbow	AISI 316

**INOXPA, S.A.**

c/ Telers, 57 – PO Box 174  
Tel: +34 972 575 200  
Fax: +34 972 575 502

17820 BANYOLES – GIRONA  
SPAIN

[www.inoxpa.com](http://www.inoxpa.com)  
e-mail: [inoxpa@inoxpa.com](mailto:inoxpa@inoxpa.com)

**BARCELONA – FLUAL, S.L.**

Tel: 937 297 280  
e-mail: [flual@inoxpa.com](mailto:flual@inoxpa.com)

**MADRID – INOXFLUID, S.L**

Tel: 918 716 084  
e-mail: [inoxfluid@inoxpa.com](mailto:inoxfluid@inoxpa.com)

**BILBAO – STA, S.L.**

Tel: 944 572 058  
e-mail: [sta@inoxpa.com](mailto:sta@inoxpa.com)

**VALENCIA – INOXDIN, S.L.**

Tel: 963 170 101  
e-mail: [inoxdin@inoxpa.com](mailto:inoxdin@inoxpa.com)

**VALLADOLID – ALTAFLUID, S.L.**

Tel: 983 403 197  
e-mail: [altafluid@inoxpa.com](mailto:altafluid@inoxpa.com)

**CÁDIZ – CORFLUID, S.L.**

Tel: 956 140 193  
e-mail: [cadiz.corfluid@inoxpa.com](mailto:cadiz.corfluid@inoxpa.com)

**ZARAGOZA – FLUAL, S.L.**

Tel: 976 591 942  
e-mail: [flual.aragon@inoxpa.com](mailto:flual.aragon@inoxpa.com)

**LA RIOJA – STA, S.L.**

Tel: 941 228 622  
e-mail: [sta.rioja@inoxpa.com](mailto:sta.rioja@inoxpa.com)

**SEVILLA – CORFLUID, S.L.**

Tel: 954 296 852  
e-mail: [sevilla.corfluid@inoxpa.com](mailto:sevilla.corfluid@inoxpa.com)

**CÓRDOBA – CORFLUID, S.L.**

Tel: 957 169 145  
e-mail: [jvilchez.corfluid@inoxpa.com](mailto:jvilchez.corfluid@inoxpa.com)

**LA MANCHA – INOXFLUID, S.L.**

Tel: 926 514 190  
e-mail: [mancha.inoxfluid@inoxpa.com](mailto:mancha.inoxfluid@inoxpa.com)

**ASTURIAS – STA, S.L.**

Tel: 985 267 553  
e-mail: [sta.asturias@inoxpa.com](mailto:sta.asturias@inoxpa.com)

**INOXPA FRANCE, S.A. - AGENCE NORD**

2, Avenue Saint Pierre  
59118 WAMBRECHIES (France)  
Tél: 33(0)320 631000  
Fax: 33(0)320 631001  
e-mail: [inoxpa.nord.fr@inoxpa.com](mailto:inoxpa.nord.fr@inoxpa.com)

**AGENCE LYON Z.A.C. D'EPINAY**

69 Allée des Caillotières  
GLEIZE 69400 (France)  
Tél: 33(0)474 627100  
Fax: 33(0)474 627101  
e-mail: [inoxpa.fr@inoxpa.com](mailto:inoxpa.fr@inoxpa.com)

**AGENCE SUD**

Route d'Olonzac  
11200 HOMPES (France)  
Tél: 33(0)468 278680  
Fax: 33(0)468 278681  
e-mail: [inoxpa.sud.fr@inoxpa.com](mailto:inoxpa.sud.fr@inoxpa.com)

**AGENCE OUEST**

ZA des Roitelières  
44330 LE PALLET (France)  
Tél: 33(0)228 010172  
Fax: 33(0)228 010173  
e-mail: [inoxpa.ouest.fr@inoxpa.com](mailto:inoxpa.ouest.fr@inoxpa.com)

**INOXPA SOLUTIONS FRANCE**

Rue Henri Becquerel  
F - 60230 CHAMBLY (France)  
Tél: 33(0)130289100  
Fax: 33(0)130289101  
e-mail: [isf@inoxpa.com](mailto:isf@inoxpa.com)

**INOXPA ITALIA S.R.L.**

Via Olivetti, s.n.c., Z.I.  
26010 VAIANO CREMASCO - Cr - (Italia)  
Tel: 39(0)373 791076  
Fax: 39(0)373 791113  
e-mail: [inoxpa.it@inoxpa.com](mailto:inoxpa.it@inoxpa.com)

**INOXPA SWEDEN**

Laxfiskevägen 12  
SE-43338 PARTILLE (Sweden)  
Tel: 46 (0) 31 336 05 60  
Fax: 46 (0) 31 336 05 61  
e-mail: [inoxpa.se@inoxpa.com](mailto:inoxpa.se@inoxpa.com)

**INOXPA SKANDINAVIEN A/S**

Høegh Guldbergsgade 27  
HORSSENS DK-8700 (Denmark)  
Tel: (45) 76 28 69 00  
Fax: (45) 76 28 69 09  
e-mail: [inoxpa.dk@inoxpa.com](mailto:inoxpa.dk@inoxpa.com)

**INOXPA SOUTH AFRICA (PTY) LTD**

HEAD OFFICE (PTY) Ltd.  
Unit 4 Production Park, Epsom Ave  
NORTHLANDS – NORTHRIDING  
JOHANNESBURG – SOUTH AFRICA  
PO Box 1464, Olivedale, 2158  
Tel: 011-796-5170  
Fax: 086-680-7756  
e-mail: [sales@inoxpa.com](mailto:sales@inoxpa.com)

**S.T.A. PORTUGUESA LDA.**

Zona Industrial - Lugar do Guardal  
ALGERIZ. 3730-266 VALE DE CAMBRA  
(Portugal)  
Tel: 351 256 472722  
Fax: 351 256 425697  
e-mail: [comercial.pt@inoxpa.com](mailto:comercial.pt@inoxpa.com)

**INOXPA POLAND sp z o.o.**

Ul. Arkonska, 54  
80-392 Gdansk (Poland)  
Tel. 48 58 511 00 05  
Fax: 48 58 556 72 51  
e-mail: [inoxpa.pl@inoxpa.com](mailto:inoxpa.pl@inoxpa.com)

**INOXRUS Ltd.**

Промзона Парнас, ул.Верхняя 4  
194292 Санкт-Петербург  
Россия  
Тел.: 7 812 622 16 26  
Fax: 7 812 622 19 26  
e-mail: [spb@inoxpa.com](mailto:spb@inoxpa.com)

**INOXPA DEUTSCHLAND GMBH**

Kohlhammerstrasse, 6  
D - 70771 LEINFELDEN  
DEUTSCHLAND  
Tel: 49 (0) 711 758 59 73  
Fax: 49 (0) 711 758 59 750  
e-mail: [rwaidelich.de@inoxpa.com](mailto:rwaidelich.de@inoxpa.com)

**INOXPA USA, Inc**

3715 Santa Rosa Avenue Suite A4  
Santa Rosa, CA95407  
(California)  
Tel: 1 707 585 3900  
Fax: 1 707 585 3908  
e-mail: [inoxpa.us@inoxpa.com](mailto:inoxpa.us@inoxpa.com)

**INOXRUS Ltd.**

ОСК Мидланд, офис 11  
Химкинский район, квартал Клязьма  
141400 Москва  
Тел.: 495 223 04 11  
e-mail: [moscow@inoxpa.com](mailto:moscow@inoxpa.com)

**INOXPA REALM Ltd.**

15, Omerside Way – Holmethorpe State  
REDHILL – SURREY RH1 2QA  
Tel: 44 2086895521  
Fax: 44 2086890245  
e-mail: [inoxpa-realm@inoxpa.com](mailto:inoxpa-realm@inoxpa.com)

**BOMBAS IMCHISA, S.A**

Calle dos, nº 9447  
QUILICURA – SANTIAGO de CHILE  
Tel: 56-2-7266945/6  
e-mail: [info@inoxpa.cl](mailto:info@inoxpa.cl)