

# Haier SERVICE MANUAL

---

Order No. Ref1009S031V0

## Refrigerator

**MODEL: HRF-660W/U**



### **WARNING**

This service information is designed for experienced repair technicians only and is not designed for use by the general public. It does not contain warnings and cautions to advise non-technical individuals of potential dangers in attempting to service a product. Product powered by electricity should be serviced or repaired only by experienced professional technicians. Any attempt to service or repair the product or products dealt with in this service information by anyone else could result in serious injury or death.

©2010 (HAIER ELECTRICAL APPLIANCES COR. LTD)

All right reserved. Unauthorized copying and distribution is a violation of law.

---

## Haier Group

Issue	2010-09-30
Rev.	Ref1009S031V1

## Contents

Table of Contents .....	1
<b>1. General Information</b> .....	<b>4</b>
1-1. General guideline	4
1-2. Insurance test	4
1-3. How to read this Service Manual	5
<b>2. Product Feature</b> .....	<b>6</b>
2-1. Specifications	6
2-2. Main functions	7
2-3. External views	8
<b>3. Disassembly and Installation</b> .....	<b>9</b>
3-1. Door and handle	9
3-2. Lamp switch	9
3-3. Wind passage cover assembly and lamp in fridge chamber .....	9
3-4. Wind passage cover assembly and lamp in freezer chamber	10
3-5. Control panel box	11
3-6. Display panel	11
<b>4. Control and Display System</b> .....	<b>12</b>
4-1. Display control board	12
4-2. Control function display	12
4-3. Fuzzy mode	12
4-4. Open-door warning	12
4-5. Malfunction display	12
4-6. Fridge ON / OFF function	13
4-7. Quick freezer function	13
4-8. Fridge lamp control	13
<b>5. Control principal and related test functions</b> .....	<b>14</b>
5-1. Air Damper	14
5-2. Control principle of fan motor	14
5-3. Defrost control	14

Issue	2010-09-30
Rev.	Ref1009S031V1

---

5-4. Self-testing function	15
<b>6. System flow principle</b> .....	<b>16</b>
6-1. System flow scenograph	16
6-2. System flow chart	16
<b>7. Circuit diagram</b> .....	<b>17</b>
7-1. Main control PCB diagram	17
7-2. Brief principle diagram	18
7-3. Sensor and error codes	18
<b>8. Trouble shooting</b> .....	<b>20</b>

Issue	2010-09-30
Rev.	Ref1009S031V1

## Chapter 1 General Information

### 1-1. General Guidelines

When servicing, observe the original lead dress. If a short circuit is found, replace all parts which have been overheated or damaged by the short circuit. After servicing, see to it that all the protective devices such as insulation barriers, insulation papers shields are properly installed. After servicing, make the following leakage current checks to prevent the customer from being exposed to shock hazards.

- 1) Leakage Current Cold Check
- 2) Leakage Current Hot Check
- 3) Prevention of Electro Static Discharge (ESD) to Electrostatic Sensitive

### 1-2. Insurance test

1. Check if there is any leak of current.
2. Cut out the power supply before the repair to avoid an electrical shock hazard.
3. In the case of a live-line test, insulating gloves should be worn to avoid potential electrical shock.
4. Confirm the rated current, voltage and capacity before testing with any kinds of instruments.
5. Watch if the upper door is open when you check something at a lower position.
6. Take out every part in the cabinet before moving the machine, especially things like panels (e.g. glass shelf).
7. Please wear intact cotton gloves when repair any parts of the evaporator, so that scratches by the sharp fins can be avoided.
8. If there is a breakdown with the refrigeration system, please surrender the machine to the service center, else the leaked refrigerant may pollute the atmosphere.
9. The refrigerator use AC of 220V with a frequency of 50~60Hz.
10. A big fluctuation of voltage (exceed the range 187~242V) may cause a start failure of the refrigerator, a burn-out of the control panel and compressor, or an abnormal sound from the compressor in operation. In this condition an automatic voltage regulator over 750W should be added.
11. Take care not to damage the supply line. Don't yank at the line; pull the plug out gently from the receptacle. Don't press the line under the cabinet or step on it. Take care not to roll on or damage the supply line when moves the machine from the wall.
12. In the case of leakage of inflammable gases like carbon monoxide, open the door and windows. Don't pull out or insert the plugs of the appliance.
13. Don't touch the refrigeration surface of the freezing compartment when the refrigerator is in operation, especially when your hand is wet, else you may be glued to the surface.
14. Pull out the plug of power supply during clearance or power outage. Wait at least five minutes to resume the power supply in order to prevent damage to the compressor caused by continuous restart.

Issue	2010-09-30
Rev.	Ref1009S031V1



## Photo used in this manual

The illustration and photos used in this Manual may not base on the final design of products, which may differ from your products in some way.

## 1-3. How to read this Service Manual

### 1-3-1. Using Icons

The meaning of each icon is described in the table below:

**Note:**

A “note” provides information that is not indispensable.

**Caution:**

A “caution” is used when there is danger, through incorrect manipulation, may damage equipment, loose data, get an unexpected result or has to restart (part of) a procedure.

**Warning:**

A “warning” is used when there is danger of personal injury.

**Reference:**

A “reference” guides to find additional information on a specific topic.

## Chapter 2 Product Feature

### 2-1. Specifications

<b>1</b>	<b>Model</b>		HRF-660W/U
	Photo		
	Product description (Refrigerator/Freezer)		Refrigerator-Freezer
	Type of appliance (FS=freestanding / BI= built-in)		FS
	Type of cooling system(NF=no frost/ S=static)		NF
	Climate class*		SN.N.ST
	Freezer compartment / Star rating		4*
<b>2</b>	<b>Key features</b>		
	Total gross volume	L	582
	Total storage volume	L	530
	Defrosting (M>manual A=autom atic)		A
	Frost free system		yes
	Defrost water outlet		yes
	Air circulating ventilator		yes
	Kind of coolant		R600a/ 80g
	Foaming components		C-P
<b>3</b>	<b>Technical data</b>		
	Voltage / frequency	V/Hz	220V-240V~/ 50
	Input power	W	200
	Cooling system: K=Compressor / A=Absorption		K
<b>4</b>	<b>Door:</b>		
	F= flat / R= rounded / S= streamline		S
	Inside color		w
	Hinged (r =right l =left) / reversible		R / L
	Freezing compartment integrated with door		No
	<b>Shelves:</b>		
	Number Fridge / Freezer	n°	4 / -
	Type (gr=grill / g=glass / p=plastic)		g / P
	Color w=white / g=green / t=transparent.		t
	Adjustable (Y=yes / N=not)		Yes
	<b>Crisper:</b>		
	Number Fridge / Freezer	n°	2 / -
	Color of crisper(s) ( t=transparent / w=white)		t

	<b>Drawer:</b>		
	Number Fridge / Freezer	n°	- / 2
	Color of drawer(s) ( t=transparent / w=white)		t
	<b>Bottle holder:</b>		
	Number Fridge / Freezer	n°	5 / 4
	Color of bottle holder(s)( t=transparent / w=white)		t
<b>5</b>	<b>Equipment &amp; accessories</b>		
	<b>Control panel:</b>		
	Interior / exterior		Interior
	Thermometer interior / exterior		Interior
	Over temperature alarm LED / acoustic		Yes
	Adjustable thermostat		Yes
	Fast freeze switch /-function		Yes
	Deodorizing		Yes
	Interior light	W	Yes
	Ice maker Manual/ Automatic		-
	Adjustable feet front / rear	n°	2 /FRONT
	Castors front / rear		- / yes
<b>6</b>	<b>Product dimensions</b>		
	Unit dimensions ( H / W / D)	mm	1768/890/770
	Net weight	kg	120

## 2-2. Main Functions

1. Whole air-cooled computer control system, there is a freezer evaporator and a fan in freezing room, fridge room through the air circulation blowing by fan to carry on the refrigeration,, fridge room is controlled through the ON/OFF of electronic damper to achieve temperature control, control freezing room temperature through the run and stop of compressor.
2. Large LED digital display to show each inner room temperature。
3. AI control function. Chamber temperature can control automatically according to the ambient temperature, and no need human intervene.
4. Malfunction self-diagnosis function. It can shows error codes automatically to help solving problems in time when system does not work properly.
5. Open-Door warning function: If the door is not properly closed, or the door is opened for an extended period , the appliance buzzer will sounds at an interval.
6. Ultra-thin door design, appearance is more concise and generous.

Issue	2010-09-30
Rev.	Ref1009S031V1

## 2-3. External views





## Chapter3 Disassembly and Installation

### 3.1. Door and handle

1. Loosen the screw by screwdriver, and then remove the hinge cover from upper way.
2. Loosen the screw fixing the upper hinge to the body and lift the door.
3. Door gasket can be pulled out from door foam assembly .

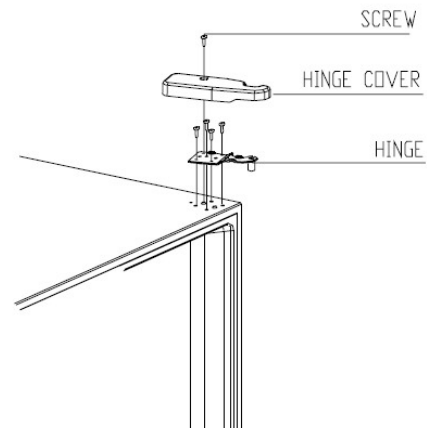

4. Fix the bolt into the hole on the door, and then use the handle aiming to the bolt, push the handled own until it touch the door firmly.

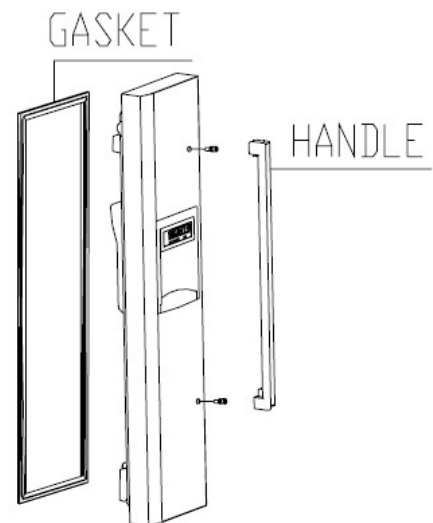

### 3.2. Lamp Switch

1. To remove the switch pulls out it with a flat type screwdriver as shown in.
2. Disconnect the lead wire from switch.

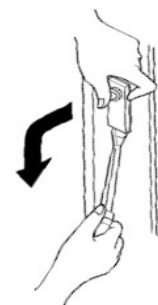

### 3.3. Wind passage cover assembly and lamp in fridge chamber

1. Unplug the power cord from the outlet;
2. Remove the fridge shelf;
3. Remove the lamp cover ;
4. The bulb can be replaced;

- Loosening 2 screws fixed to ceiling of inner liner;
- Pull out the electric damper, wind passage and the wind passage cover;
- After replaced the disabled parts, assemble in reverse order of disassembly.

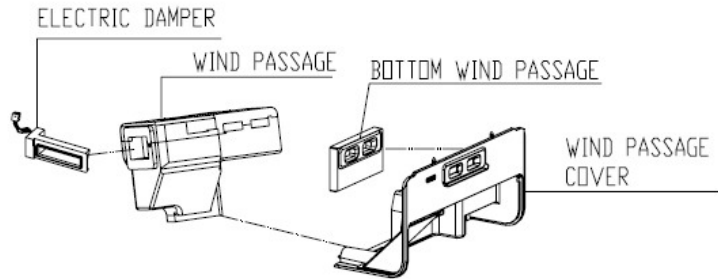
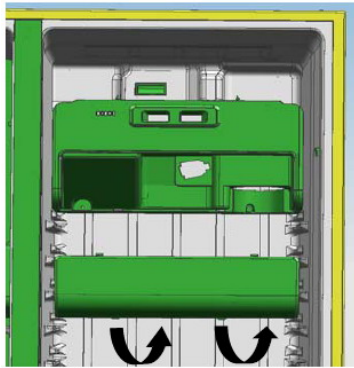

### 3.4. Wind passage cover assembly and lamp in freezer chamber

- Unplug the power cord from the outlet;
- Remove the freezer shelf;
- Remove the lamp cover;
- The bulb can be replaced;
- Loosening 2 screws fixed the cover and pull out the top freezer air tower;
- Pull out the bottom freezer air tower and unplug the sensor cable;
- Pull out the freezer rack, unplug the fan motor cable and separate the fan motor cover and the rack.

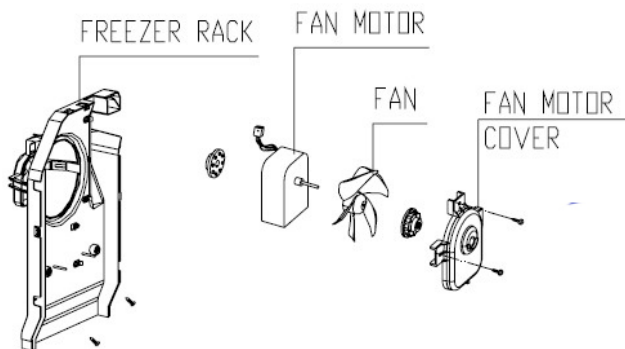
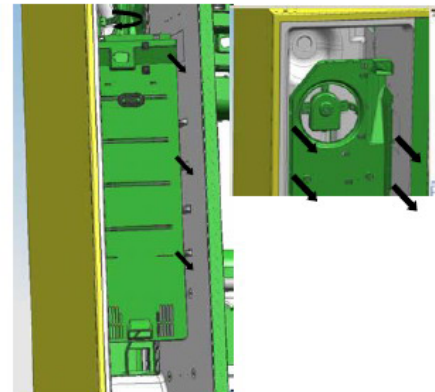
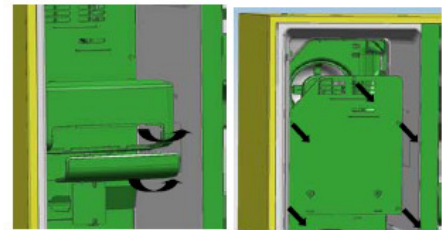

- Pull out the freezer air shutter;
- Unplug the defrost sensor cable and replace it;
- Assemble in reverse order of disassembly.

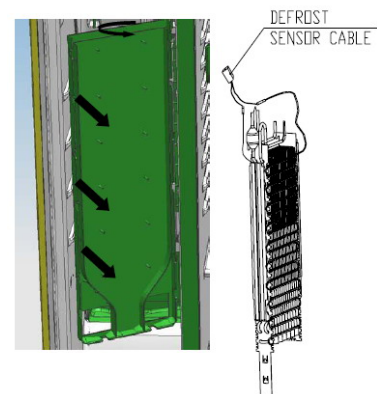

Issue	2010-09-30
Rev.	Ref1009S031V1

## 3.5. Control panel box

1. Unplug the power cord from the outlet;
2. Lossening 4 screws fixed the control panel box cover;
3. Open the cover;
4. Replace or check the control panel if necessary.

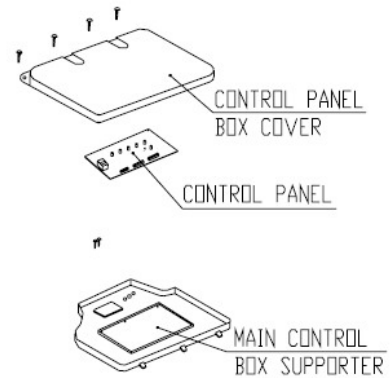

## 3.6. Display panel

1. Unplug the power cord from the outlet;
2. Lossening 2 screws fixing the bottom of control panel assembly;
3. Unplug the display panel;
4. Lossening 4 screws fixing the control panel.

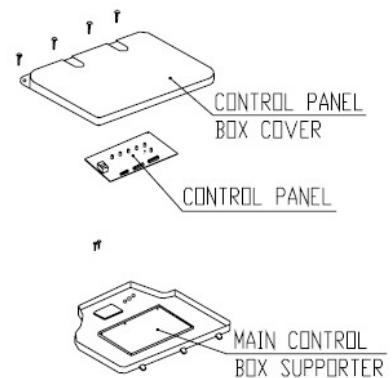

## Chapter 4 Control and display system

### (1) Display control board

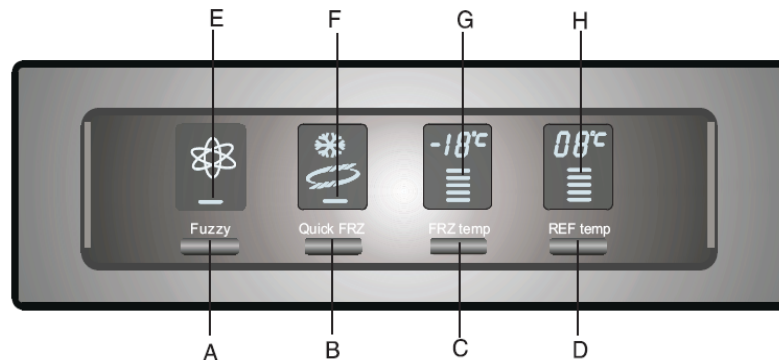

- A. Fuzzy mode
- B. Super freeze
- C. Freezer temperature
- D. Refrigerator temperature
- E. Fuzzy mode indicator
- F. Freezer indicator
- G. Freezer temperature indicator
- H. Refrigerator temperature indicator

### (2) Control function display

30 minutes later after the final press of button, display will be blank. Previous display can be resumed if any button is pressed or any door opened.

### (3) Fuzzy mode

If fuzzy mode is activated, the appliance will adjust inside temperature automatically according to ambient temperature. Fuzzy mode is activated and inactivated by consecutive press of button A, then light E will be turned on and off.

NOTE: Fridge temperature can not be adjust in Fuzzy mode.



### (4) Open-door warning

If the door is not properly closed, or the door is opened for an extended period (more than 60 seconds), the appliance buzzer will send out 3 alarm sounds at an interval 30 seconds, until the door is closed properly.

### (5) Malfunction display

If control or function system does not work properly, information of refrigerator or freezer compartment temperature will not be display, This will not affect the cooling effect in short period of

time. User should contact authorized after-sales service for technical assistance in time.

### (6) Fridge ON/OFF function

Hold button D pressed for 3 seconds, the refrigerator performance ceased and icon H goes out, leaving refrigerator light under normal status.

If refrigerator performance ceased, hold refrigerator temperature button D for 3 seconds again, icon H will appear and refrigerator performance will be resumed.



### (7) Quick freeze function

Press button B, indicator F lights, and super freeze mode is activated. If button B is pressed again, indicator F goes out and super freeze mode is inactivated.

Super freeze function is designed to preserve the nutritional value of food, as the food will freeze completely in the shortest period possible with compressor continual running. The appliance will exit super freezer mode after continual running for 4 hours.

NOTE: Freezer temperature can not be adjust in Super Freezer mode.

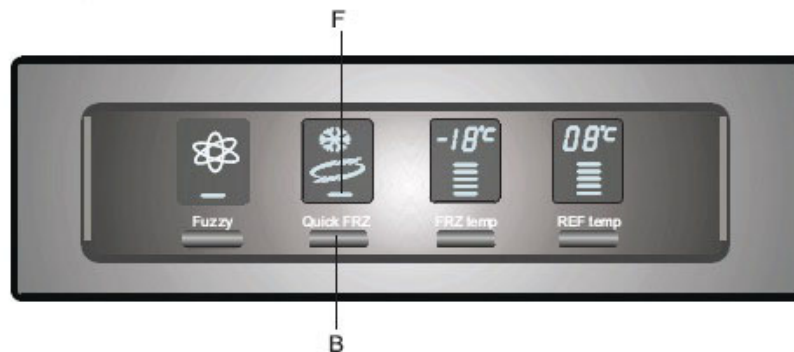

### (8) Fridge lamp control

When the fridge door is open, lamp will be light, and if keep the door open more than 7 minutes, lamp will extinguish automatically.

Issue	2010-09-30
Rev.	Ref1009S031V1

## Chapter 5 Control principal and related test functions

### 5-1. Air damper

- 1) Refrigerating sensor R1 controls the startup and shut down of air damper in refrigerator compartment.
- 2) The air damper is closed (in order to prevent the compartment from freezing) within 15 minutes from the beginning to the finishing of defrosting.
- 3) Force the air damper to be opened and closed once if it can not be opened within 1 hour. After that, decide whether open or close it according to R1 sensor.
- 4) The air damper heater and ice dispenser heater work in-phase.
- 5) Environment temperature is above 12°C, the heater of bar will be on, when lower than 10°C, heater will be off.
- 6) Dispenser heater and water drain pipe heater will be off for 10 minutes and 30 minutes on, thus a circulation.

### 5-2. Control principle of fan motor

Control of freezing fan:

When open the refrigerating door, the refrigerating air damper will be turned on, and the freezing fan will be working, after 2 minutes the refrigerating air damper will be turned off.

When open the freezing door, If the freezing fan works at a speed of 1500 RPM, the freezing fan will keep working but switch to 1300 RPM. If the fan works at a speed of 1300 RPM, it will shut off when the freezing door is open.

Control of refrigerating fan:

This fan is working in-phase with the compressor and at a fixed speed of 1100 RPM.

### 5-3. Defrost control

Automatic defrost: After added up to 7 hours of compressor running, defrost will be switched on. When defrost SNR temperature reaches 7°C, defrost will be over.

If the defrosting time is more than 120 minutes, and defrost sensor still can not reach to 7°C, it will stop defrosting process and give warning error indicator—display error code F6..

Easily failure components of defrosting system:

- 1) Defrosting fuse: It is located in the left side of evaporator. If the fuse is open circuit, means it is defective.
- 2) Connectors: The frequently failure phenomenon is that pin of connectors is dislocation or oblique.
- 3) Defrosting sensor: It is located in the upper right side of evaporator, the sensor control the defrosting time.

## 5-4. Self-testing function

About self-test function:

(1) With self-test function, the appliance can quickly check the working condition of fan, compressor and defrost heater.

(2) How to enter and quit: press the test button on the main control board once, and enter the forced starting mode, and a second time press to enter forced defrosting mode.

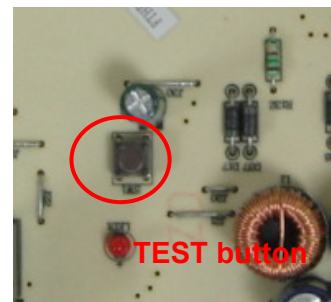

MODE	OPERATION	WORKING CONDITION	REMARKS
TEST1	Press test button once to enter Forced Start mode.	(1) compressor forced start. (2) freezing fan work at high speed (3) refrigerating fan work (4) heater shut down (5) air escaper opens	Press test button two times to quit this mode.
TEST2	Under test 1 and press test button again to enter Forced Defrost mode.	(1) compressor shut down (2) no fan works (3) Defrost heater works (4) air escaper closes	Press test button one time to quit this mode.
Resume normal mode	Press test button for a third time.	Resume to normal mode and the compressor will start in 7 minutes.	

## Chapter 6 System flow principle

### 6-1. System flow scenograph

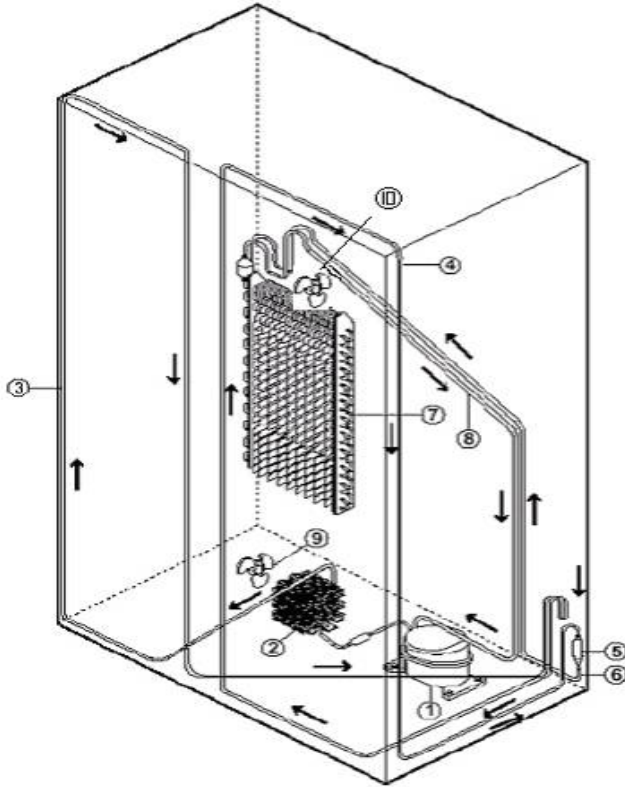

- (1) Compressor
- (2) Condenser
- (3) Hot connector pipe for freezer
- (4) Hot connector pipe for fridge
- (5) Drier filter
- (6) Capillary tube
- (7) Evaporator
- (8) Suction pipe
- (9) Compressor DC fan motor
- (10) Freezer DC fan motor

This product adopts an air-cooled refrigeration system to ensure accurate refrigeration in freezer compartment and refrigeration compartment.

### 6-2. System flow chart

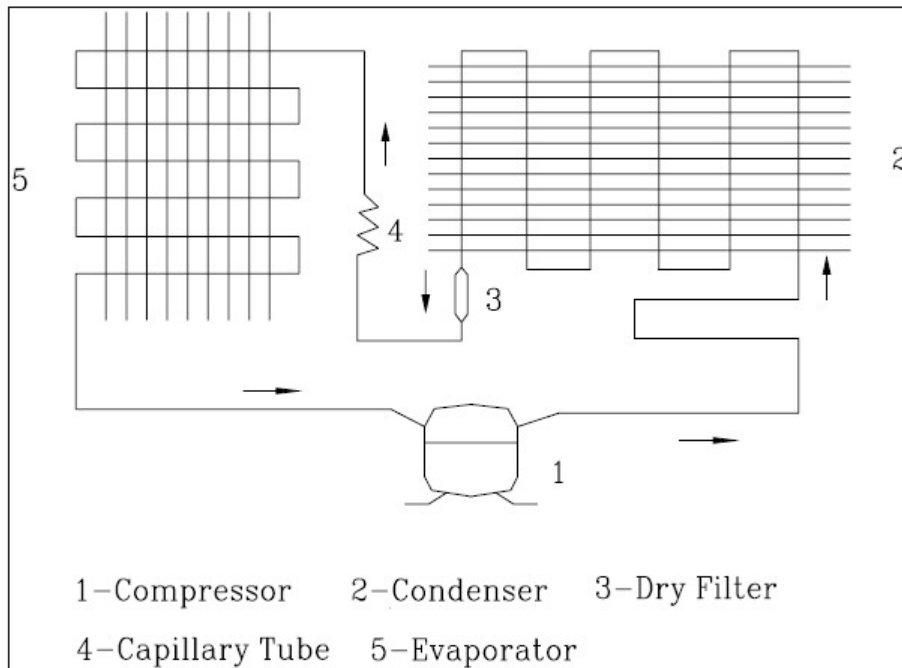



## Chapter 7 Circuit diagram

### 7-1. Main control PCB diagram

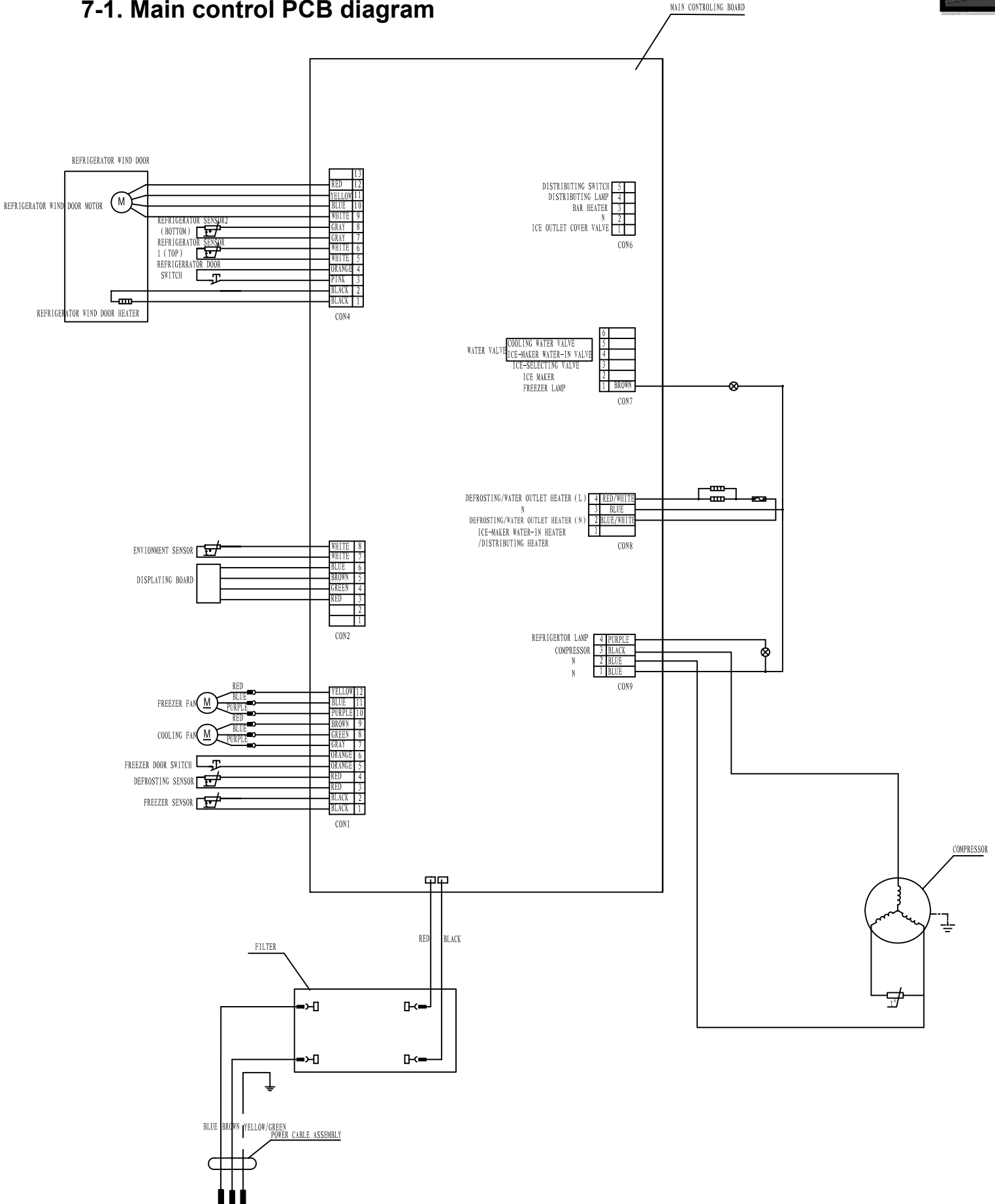

Issue	2010-09-30
Rev.	Ref1009S031V1

## 7-2. Brief principle diagram

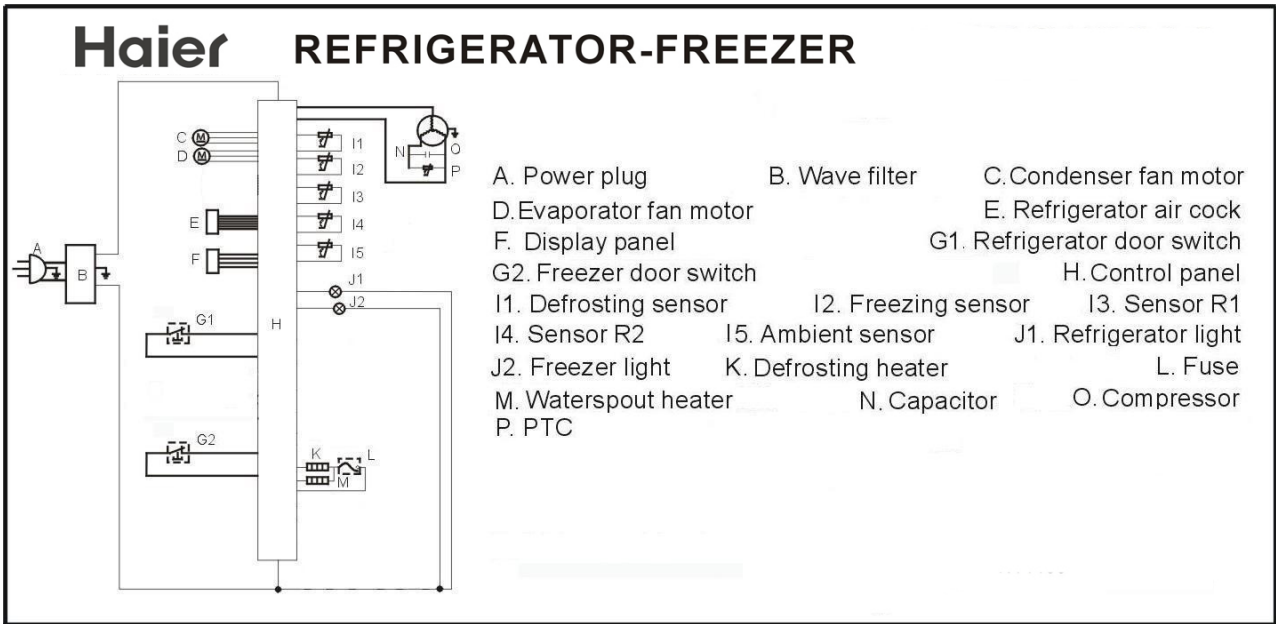

## 7-3. Sensors and error codes

Sensor Location:

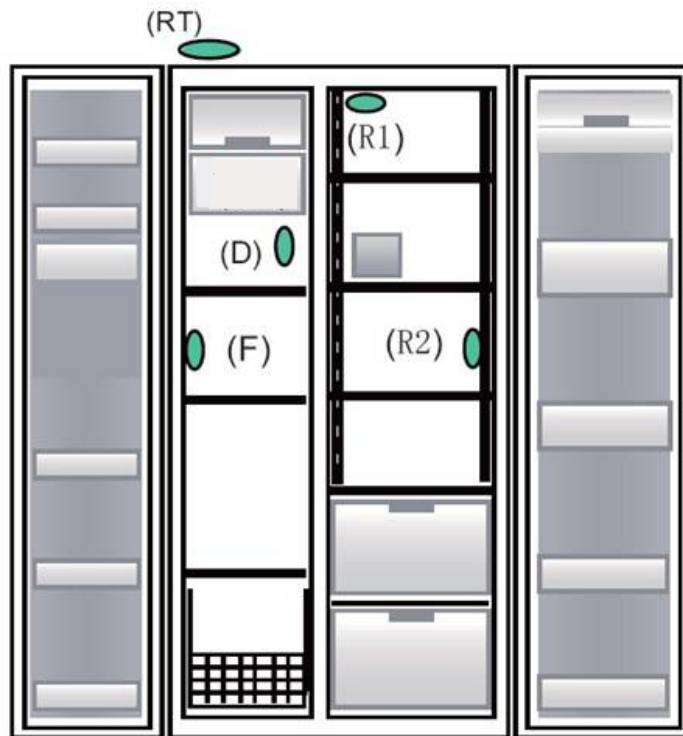

# SERVICE MANUAL

Model: HRF-660W/U

Issue	2010-09-30
Rev.	Ref1009S031V1

19

Sensor name	Sensor marker	Sensor location	Function
RT sensor	RT SNR	under the right hinge box	measure the temp. of the circumstance
Refrigerator sensor 1	R1 SNR	beside the air-vent in REF	measure the temp. of the air
Refrigerator sensor 2	R2 SNR	on the right side of the REF cabinet	measure the temp. of the REF compartment
Defrosting sensor	D SNR	on the top of the evaporator in FRZ	measure the temp. of the evaporator
Freezer sensor	F SNR	middle of freezer compartment	measure the temp. of the FRZ compartment

## Error code list:

NO	Malfunction	Error Indicator		Error code meaning
		F SET	R SET	
1	F SNR failure	F4	normal	F SNR is short circuit or open circuit
2	RT SNR failure	normal	F3	RT SNR is short circuit or open circuit
3	R1 SNR failure	normal	F1	R1 SNR is short circuit or open circuit
4	R2 SNR failure	normal	F2	R2 SNR is short circuit or open circuit
5	D SNR failure	normal	F6	D SNR is short circuit or open circuit
6	Freezer fan motor failure	normal	E1	more than 30 seconds without signal
7	Condenser fan motor failure	normal	E2	more than 30 seconds without signal
8	Failure communication	normal	E0	No reflect when setting ,between display PCB and Power PCB no signal transmitted over 2 min
9	Defrosting system failure	normal	Ed	can not reach -12°C within 2 hours

## Chapter 8 Trouble shooting

<b>Water/moisture/frost in the refrigerator</b>		
Moisture accumulates on the refrigerators inner walls	<ul style="list-style-type: none"> <li>● Hot and moist climate.</li> <li>● The door is not closed tightly</li> <li>● The door is opened too frequently or for too long time</li> </ul>	<ul style="list-style-type: none"> <li>● Accumulation of frost and moisture accelerate in such climate.</li> <li>● Make sure the refrigerator is level and there is no food or container interfering with the door</li> <li>● Do not open the door so frequently</li> </ul>
<b>Water/moisture/frost on outside surface of the refrigerator</b>		
Moisture accumulates on the refrigerator's outside surface or between two doors	<ul style="list-style-type: none"> <li>● Damp climate</li> <li>● The refrigerator door is not closed tightly. This causes mixing of the cold air in the refrigerator with the warm air outside it</li> </ul>	<ul style="list-style-type: none"> <li>● It is normal in damp climate. The moisture will decrease when the humidity drops.</li> <li>● Make sure the refrigerator is level and there is no food or container interfering with the door</li> </ul>
<b>Refrigerator operation</b>		
The compressor does not work	<ul style="list-style-type: none"> <li>● The refrigerator is in defrosting cycle.</li> <li>● The refrigerator is not plugged into a power outlet.</li> <li>● The refrigerator is in OFF state.</li> </ul>	<ul style="list-style-type: none"> <li>● It is normal for an automatic defrosting refrigerator.</li> <li>● Verify the plug is plugged in the socket firmly.</li> <li>● Press the "Power" button for 3 second or more to restart the refrigerator or turn the knob from OFF to temperature selection position.</li> </ul>
The fridge storage compartment does not work	<ul style="list-style-type: none"> <li>● The air door cable is not connected properly.</li> <li>● The fan does not work</li> <li>● The fridge storage compartment is turned off</li> </ul>	<ul style="list-style-type: none"> <li>● Check if the air door cable is not connected properly and install it correctly if not so. Verify that the air door acts normally with the Fridge ON/OFF key on the display panel</li> <li>● The fan does not work while the refrigeration air door is open. Please check if the door on-off behind the front decoration strip is installed properly. Reinstall it correctly if not so.</li> <li>● Turn on the fridge storage compartment manually</li> </ul>
The refrigerator runs frequently or runs for too long period	<ul style="list-style-type: none"> <li>● The indoor or outdoor temperature is high</li> <li>● The refrigerator has been powered off for a period of time.</li> <li>● The automatic icemaker is operating.</li> <li>● The door is opened too frequently or for long periods.</li> <li>● The door of the fridge / freezer storage compartment is not tightly closed.</li> <li>● The temperature setting for the freezer storage compartment is too low</li> <li>● The door gasket of the fridge/freezer storage</li> </ul>	<ul style="list-style-type: none"> <li>● In this case, it is normal for the refrigerator to run longer.</li> <li>● Normally, it takes 8 to 12 hours for the refrigerator to totally cool down.</li> <li>● Icemaking process makes the refrigerator to run longer.</li> <li>● Warm air enters the refrigerator and causes it to start frequently. Please do not open the door so frequently.</li> <li>● Make sure the refrigerator is level place and there is no food or container interfering with the door.</li> <li>● Set the temperature higher until satisfactory refrigerator temperature is obtained. It takes 24 hours for the refrigerator temperature to become stable.</li> <li>● Clean or replace the door gasket. Leakage gap of door gasket can cause</li> </ul>

Issue	2010-09-30
Rev.	Ref1009S031V1

	<p>compartment is dirty, worn, cracked or mismatched.</p> <ul style="list-style-type: none"> <li>● The condenser is dirty.</li> </ul>	<p>longer running time of the refrigerator in order to maintain desired temperature.</p> <ul style="list-style-type: none"> <li>● Clean the condenser.</li> </ul>
<b>Too high temperature</b>		
Too high temperature in the fridge/freezer storage compartment	<ul style="list-style-type: none"> <li>● The door is opened too frequently or for too long periods of time</li> <li>● Temperature is set too high</li> <li>● The door is not closed tightly</li> <li>● The condenser is dirty</li> </ul>	<ul style="list-style-type: none"> <li>● Warm air will enter the refrigerator whenever the door is opened. Try to open the door as infrequently as possible.</li> <li>● Reset the temperature.</li> <li>● Make sure the refrigerator is on a level surface and there is no food or container interfering with the door.</li> <li>● Clean the condenser.</li> </ul>
The temperature in the freezer storage compartment is too high while the temperature in the fridge storage compartment is OK	<ul style="list-style-type: none"> <li>● The temperature is set too high</li> </ul>	<ul style="list-style-type: none"> <li>● Set the freezer temperature lower. It takes 24 hours for the temperature of the refrigerator to become stable.</li> </ul>
The temperature in the fridge storage compartment is too high while the temperature in the freezer storage compartment is OK	<ul style="list-style-type: none"> <li>● The temperature is set too high</li> </ul>	<ul style="list-style-type: none"> <li>● Set the fridge temperature lower. It takes 24 hours for the temperature of the refrigerator to become stable.</li> </ul>
<b>Bad odors in the refrigerator</b>		
The inside of the refrigerator is dirty	<ul style="list-style-type: none"> <li>● The inside of the refrigerator needs cleaning</li> <li>● Food with strong odor is stored in the refrigerator</li> </ul>	<ul style="list-style-type: none"> <li>● Clean the internal of the refrigerator</li> <li>● Wrap the food tightly.</li> </ul>
<b>If you hear...</b>		
Beeps	<ul style="list-style-type: none"> <li>● The fridge storage compartment door is open</li> <li>● The temperature in the freezer storage compartment is too high</li> </ul>	<ul style="list-style-type: none"> <li>● Close the door or silence the alarm manually</li> <li>● The alarm is normal when it is first started due to relatively higher temperature.</li> </ul>
Abnormal sound	<ul style="list-style-type: none"> <li>● The refrigerator is not located on a level surface</li> <li>● The refrigerator touches some object around it</li> </ul>	<ul style="list-style-type: none"> <li>● Adjust the feet to level the refrigerator.</li> <li>● Remove objects around it.</li> </ul>
Slight sound similar to that of flowing water	<ul style="list-style-type: none"> <li>● It is the sound of the refrigerating system</li> </ul>	<ul style="list-style-type: none"> <li>● Normal.</li> </ul>
Heating of cabinet	<ul style="list-style-type: none"> <li>● The de-dew tube is de-dewing</li> </ul>	<ul style="list-style-type: none"> <li>● It is a process to prevent dewing. It is a normal phenomenon.</li> </ul>

**Sincere forever**

**Haier Group**

**Haier Industrial Park, No.1, Haier Road**

**266101, Qingdao, China**

**<http://www.haier.com>**