

# Roadranger®

Dana® Spicer® Drive Axles

Failure Analysis



One Great Drivetrain from Two Great Companies

Service Manual

AXSM-0020

June 2004



For the most current information, visit the Roadranger web site at [www.roadranger.com](http://www.roadranger.com)

**This page intentionally left blank.**

# Table of Contents

---

## Introduction

Overview .....	1
----------------	---

## Failure Prevention

Correct Specifications .....	2
------------------------------	---

## Glossary and Nomenclature

Glossary .....	6
Stress Overview .....	8

## Gearing and Torque Distribution

Power Flow .....	15
------------------	----

## Failure Analysis

How to Diagnose a Failure .....	17
---------------------------------	----

## Ring Gear and Pinion

Shock (Impact) Failure .....	19
Fatigue Failure .....	20
Pitting and Spalling Failures .....	21
Lubrication Failures .....	22

## Wheel Differential

Shock (Impact) Failures .....	23
Spinout - Over Heat Failures .....	24

## Power Divider

(Impact) Failure .....	25
Fatigue Failures .....	27
Pitting and Spalling Failures .....	28
Spinout Failures .....	29
Lubrication Failures .....	31

## Bearings

Normal and Contamination Wear .....	32
Pitting and Spalling Damage .....	33

## Seals and Yokes

Yoke Wear and Seal Lip Wear .....	34
Installation Problems .....	35

## Axle Shaft

Shock and Fatigue Failure .....	37
---------------------------------	----

## Drive Axle Housing

Spindle Damage and Fatigue Cracks .....	38
Loose or Over-torqued Hardware .....	39

## Steer Axle

Bushing Damage - Installation .....	40
-------------------------------------	----

## Two Speed Planetary

Pitting and Spalling Failures .....	43
Wear and Scoring .....	44

# Introduction

---

## Overview

This document is a general reference guide to mechanical failures of heavy truck axles. We approach the subject of axle failure from several perspectives ranging from basic principles of drive train operation to the evidence available from examining failed parts.

In preparing this guide, our objective was to help the skilled technician identify all the contributing causes of drive axle failures. With improved understanding of how and why an axle failed, the technician will not only be able to repair the carrier successfully, but also pinpoint any conditions that may need to be changed to prevent a repeat failure.

Here is an overview of the different sections of this guide:

- **Failure Prevention** - Explains how to prevent axle failures through proper procurement, operation, and maintenance.
- **Glossary and Nomenclature** - Covers the terminology of axle components including function, fatigue, and failure. This section illustrates the primary forms of mechanical stress and also provides gearing and gear tooth nomenclature.
- **Gearing and Torque Distribution** - Reviews the principles of power flow through drive axles in various gear ranges and equipment configurations. This section also illustrates different forms of spin-out, a major operating cause of axle failure.
- **Failure Analysis** - Explains how to diagnose the cause of a component failure. The main feature of this section is a photographic review of actual failed parts matched with a description of the failure, the probable cause, and methods of prevention.

At Spicer Heavy Axle and Brake Division of Dana Corporation, we are interested in knowing your reaction to this guide and we welcome comments and contributions to future reference materials. Contact your Spicer representative or contact us directly at [www.Dana.com](http://www.Dana.com).

# Failure Prevention

## Correct Specifications

This section considers three general areas of truck procurement, operation and maintenance that will help prevent axle failure:

- Correct Specifications - matching the axle to the load and expected road conditions
- Drive Practices - training combined with proper use of installed equipment
- Maintenance, Rebuilding and Adjustment - with special emphasis on lubrication

Correctly spec'ing a drive axle for the vehicle and for the job to be done is an essential factor in preventing axle failures. It is extremely important to spec an axle of sufficient strength to work under the planned vehicle operational environment as well as the vehicle load rating.

Operating a vehicle outside of the specification (i.e., overloading and/or operating under more demanding conditions) may increase torque requirements and could cause premature damage or failure of axle components.

The drive axle must be designed with strength capable of withstanding the punishment of a loaded truck in operation. All components - gears, shafts, bearings, and housing - must meet three essential requirements:

- To carry the load. In most instances, the drive axle supports the major portion of the truck and its payload.
- To withstand the stress of torque developed by the engine and multiplied by the drive train.
- To withstand the stress of impact and shock forces created by road conditions and vehicle operation.

The capability of a drive axle to carry its share of the vehicle load is expressed as axle rated capacity Gross Axle Weight Rating (GAWK). To prevent axle overloading, the axle rating must be compatible with the weight specification of the vehicle, load, and expected operating conditions. Overloading will cause damage to the axle assembly parts.

See Spicer Drive Axle Application Guidelines (AXAG-0200).

### Torque is Important

The primary function of a drive axle is to provide gear reduction which multiplies torque and transmits it to the driving wheels. In a truck power train, the engine develops horsepower and delivers the power in the form of torque. The transmission multiplies this torque and delivers it to the drive axle which multiplies torque a second time.

The drive axle gearing and its related components must be designed to transmit this torque to the driving wheels, so they will move the combined weight of the vehicle and load over expected road conditions.

Torque requirements vary with different grades and road conditions. Off-highway vehicles such as construction trucks must operate on rough or soft surface roads and steep grades. This requires greater torque for efficient operation. Vehicles with equivalent load ratings and operating at constant speeds on highways require less torque.

### Vehicle Load Ratings

There are two different vehicle load ratings:

- **Trucks** are rated by Gross Vehicle Weight (GVW) which is the truck weight plus the weight of its load.
- **Tractor-trailer rigs** are rated by Gross Combination Weight (GCW) which is the weight of the tractor, trailer, and payload.

These ratings, as they relate to engine power and the torque required to move the weight, determine the required axle gearing strength.

### Vehicle Operation

A vehicle is designed to do a certain job under certain conditions. More severe use of the vehicle such as overloading or operating under adverse road conditions not considered when spec'ing the axle is termed misuse or incorrect operation. Under severe misuse, the axle could fail immediately. With lesser misuse, the axle parts could progressively fail over a period of time. When unusual operating conditions are anticipated, get professional help in spec'ing a drive axle.

# Failure Prevention

---

## Driving Practices

Driving practices have a large influence on the service life of a truck axle. Good driving practices can eliminate shock and prevent undue strain not just on the axle, but on the entire truck.

There are two driver practices that are detrimental to axle parts life:

- Subjecting the vehicle to undue rough handling
- Driving under road conditions not specified

Either of these practices could cause premature axle failure.

Even conscientious drivers may encounter an unusual adverse situation of an exceptionally rough road. The driver should be trained to regulate speed and brake application according to road conditions.

### Training is Essential

Driving a truck is an important job that can be performed more effectively with thorough training. The driver needs to know all the specifics about the hauling job such as payload characteristics, anticipated road conditions, and roads to be avoided. The driver must also be well informed about the equipment. For example, the driver should know answers to such questions as:

- What was the truck designed for?
- Why does the truck have a differential lockout?
- What is the function of a controlled traction differential?
- What are the benefits of 2-speed gearing in the drive axle?

A well-informed driver with proper training will eliminate many drive axle failures.

### Failure-Preventing Equipment

Spicer tandem axles incorporate design features that can help prevent axle failures. Four important equipment features are:

- Inter-axle Differential Lockout
- Controlled Traction Differential
- 2-Speed (Dual Range) Gearing
- Drive Axle Wheel Differential Lock

The driver must know the purpose as well as the proper use of these important design features.

### Inter-axle Differential Lockout

See Spicer Driver Instruction AXDR-0126.

The inter-axle differential lockout increases traction effort under adverse road conditions.

When engaged, the lockout provides positive drive to both axles. When the drive wheels of one axle are subjected to a condition of wheel spinning, the drive will continue to the other axle (to the wheels with traction) and move the truck.

Proper use of this lockout feature is important:

- Do not engage lockout while wheels are spinning.
- Do not engage lockout when driving conditions are good.

Improper use of the lockout could result in unnecessary axle parts failure.

## **Controlled Traction Differential**

A controlled traction differential is a biasing unit designed into the axle wheel differential. It provides the truck with effective traction control under adverse driving conditions, especially off the highway. A controlled traction differential is especially effective in minimizing the possibility of spinout.

## **2-Speed (Dual Range) Gearing**

See Spicer Driver Instruction AXDR-0134.

Spicer drive axles are equipped with 2-speed gearing to provide maximum operating efficiencies in two extreme situations:

- Off-highway fully loaded
- On-highway fully loaded

The low range provides deep reduction and maximum torque when off-highway or on steep grades. The high range provides a faster ratio for cruising and fuel economy.

Premature failures of shifting parts, drive axles, and other drive train components can be prevented by proper driving per manual instructions and training. There are two important rules to follow:

- Do not abuse axle-shifting parts. Follow the instructions for shifting the axle.
- Do not abuse the drive train components. Use low range when torque requirements are high such as on rough roads, on steep grades, and under other adverse conditions.

## **Drive Axle Wheel Differential Lock**

See Spicer Drive Instruction AXDR-0130.

The drive axle wheel differential lock is an air-actuated clutch which positively locks the differential gearing in the rear axle. When this clutch is engaged, power flows to the tires without any differential action, giving each wheel all the torque the road conditions will permit.

A cab-mounted valve moves the wheel differential lock in or out of engagement. This motion also trips an electrical switch that activates a light in the cab or sounds an audible device to indicate that the wheel differential lock is engaged.

When the clutch is disengaged, the differential operates normally, dividing torque equally between the tires and compensating normally for cornering or tire size variations.

# Failure Prevention

---

## Maintenance, Rebuilding, and Adjustment

Proper maintenance is essential to achieve the maximum life designed and built into a drive axle. Perhaps the most important element of maintenance is proper lubrication. Incorrect or lack of lubrication is extremely detrimental to the life of drive axle parts.

Lubricant is the life-blood of the axle gears and bushings. It prevents metal-to-metal contact and keeps the parts clean and running cool. To get all the benefits of lubrication, you must:

- Use the proper lube.
- Maintain the proper lube level.
- Change lube at specified intervals.
- Periodically clean magnetic plugs.
- Clean the magnetic drain plug to remove metallic dust or fine particles.
- Keep filters and strainers clean and filled after an initial break-in of 5,000 miles. When filled with an Eaton approved synthetic lubricant at the factory, the 5,000 mile drain is not required.

To assure correct lubrication and long life for your Spicer drive axle, follow instructions in the Spicer Service Manuals. For additional lubrication information, see TCMT-0021.

### **Rebuilding and Adjusting**

Proper reassembles and replacement of all damaged or defective parts is extremely important in achieving good life from an axle overhaul. Cleaning and close inspection of parts is vital.

To achieve maximum value from a rebuild, replace lower cost items such as thrust washers, seals, and bushings as well as worn and damaged major parts.

Follow instructions for correctly adjusting bearing preloads, shaft endplay, and gear and pinion tooth contact patterns.

All these procedures will help extend the life of your rebuilt axle. Refer to Spicer Axle Service and Maintenance Literature for detailed information.



# Glossary and Nomenclature

## Glossary

**Abrasion** - The process of rubbing, grinding, or wearing away of material from a surface by friction.

**Backface Runout** - The total amount of movement in the back-face surface of the ring gear during one revolution.

**Backlash** - The total amount of movement between two mating gears.

**Beach Marks** - Contour lines on a somewhat smooth failed surface that indicate fatigue. Beach marks occur as a part successfully resists, for a time, the advance of a fatigue crack.

**Bending Fatigue** - Characterized by beach marks on the fractured area. The phenomenon leading to fracture under repeated or fluctuating stresses having a maximum value less than the tensile strength of the material. Fatigue fractures are progressive, beginning as minute cracks that grow under the action of the fluctuating stress. Fatigue results from load and time.

**Brinelling, False** - Depressions produced when bearings are subjected to vibration or low radial-angle oscillation, or to both, while not rotating. The bearing surfaces are either polished or show a characteristic red-brown stain.

**Brinelling, True** - Indentation produced by plastic flow when rolling elements are forced against the bearing raceway surfaces by stationary overload or, especially, by impact during mounting. Original surface features such as machine marks are usually visible at the bottom of the indentations.

**Burnishing** - In sliding contacts, the oxidation of a surface due to local heating in an oxidizing atmosphere.

**Bruising** - A type of damage caused by foreign material or hard particles passing through the rollers and the races. Damage appears as small indentation and or denting.

**Burning** - Permanent damage to metal or alloy by overheating.

**Carrier** - The primary casting that supports and houses the rest of the components of the head assembly.

**Coking** - A lubricant that has been overheated for an extended length of time may cause the carbon in the lube to separate and collect on internal components. The build up will have the appearance of black paint.

**Fatigue Strength** - The maximum stress that can be sustained for a specified number of cycles without failure.

**Final Fast Fracture Zone** - The part of a breakthrough cross section that has a rough, crystalline appearance. It could be the entire area in a shock failure or a small part of a cross section area in a fatigue failure.

**Flaking** - See Surface Fatigue Progression.

**Fretting** - An action that results in surface damage, especially in a corrosive environment where there is a relative motion between solid surfaces in contact under pressure.

**Frosting** - See Surface Fatigue Progression.

**Galling** - The transfer of material between two moving components at extremely high temperatures.

**Grooving** - Chips of metal particle contaminates become wedged in the softer cage material and cut grooves in the rollers resulting in the grooving of the cup and cone races.

**Head Assembly** - The entire drive unit consisting of the D-Head and the R-Head. The axle housing and wheel equipment are not included in the head assembly.

**I.A.D.** - Inter-axle differential.

**Lubrication Break Down** - When a lubricant is thermally stressed, the viscosity is lowered and the lube can no longer maintain a barrier between metal parts.

**Oil Contamination** - Pollution of lubricating oil by a foreign substance.

**Overloading** - A load or torque that is greater than the design load or torque specification of a particular component.

- a. **Shock Load** - Instantaneous overload. A very rapidly applied force that causes immediate component damage.
- b. **Sustained Overload** - A consistent application of force that is greater than the part can withstand.

**Pitting** - See Surface Fatigue Progression

**Plastic Deformation (Plastic Flow)** - Deformation that remains permanent after removal of the load which caused it. An example of plastic deformation is metal flow on the surface extending over the tips of gear teeth. This condition can quickly become destructive pitting.

# Glossary and Nomenclature

---

**Radial Runout** - Refers to the total amount of movement of the outside diameter of the ring gear during one revolution.

**Rear Axle** - The drive axle located in front of the rear, rear drive axle. This axle will have a power divider unit and is described as D-Head in Spicer Literature.

**Rear Rear Axle** - The drive axle located the furthest to the rear of a tandem set of axles. This axle is described as the R-Head in Spicer Literature.

**Scoring** - Damage caused by embedded particles of metal. Scoring may show up as either deep, wide grooving or narrow, shallow grooves.

**Scuffing** - Adhesive wear from progressive removal of material from a rubbing surface caused by a localized welding and tearing.

**Shock Load** - A rapidly applied load or force that is severe enough to exceed the strength of the component and cause it to crack or fail instantly.

**Sustained Overload** - A consistent application of force that is greater than the part can withstand

**Spalling** - See Surface Fatigue Progression

**Stress** - Force per unit of area, often defined as force acting through an area within a plane.

**Stress Risers** - Changes in contour or discontinuities in structure that cause local increases in stress.

**Surface Fatigue Progression** - There are four stages of fatigue for the surface of a metal part under operating stress:

- a. **Frosting** - Superficial material displacement on gear teeth that present a non-destructive burnished appearance.
- b. **Pitting** - This surface fatigue condition occurs when the endurance limits of the material are exceeded.
  1. **Initial** - This is the mildest stage of pitting. It consists of definite pits from a pin hole size to .030" in diameter. Initial pitting continues until the tooth is able to carry the load without further distress.
  2. **Moderate**- In this stage, the pits are approximately double in size of the initial pitting. The gear teeth have not been weakened and there is no danger of breakage.

3. **Destructive** - At this stage the pits are considerably larger and deeper than those with moderate pitting. Gears found in this stage should be replaced.

- c. **Flaking** - An advanced type of pitting resulting from contact fatigue. Material falls away from the surface in the form of shallow flakes or scale-like particles.

- d. **Spalling** - Deterioration of a highly stressed surface by surface fatigue producing irregularly shaped, sharp-edged, deep cavities. Spalling is a severe form of flaking.

**Torsion** - A twisting action resulting in shear stresses and strains.

# Glossary and Nomenclature

## Stress Overview

Most failures involve some form of mechanical stress. Even when the initial or basic cause of the failure results from a problem such as excessive heat or improper lubrication, the part becomes weakened and more subject to stress failure.

This page illustrates four basic forms of mechanical stress: torsion, tensile, shear, and compression. In the Failure Analysis section, parts photographs show the resulting failures and the patterns characteristic of the different stresses.

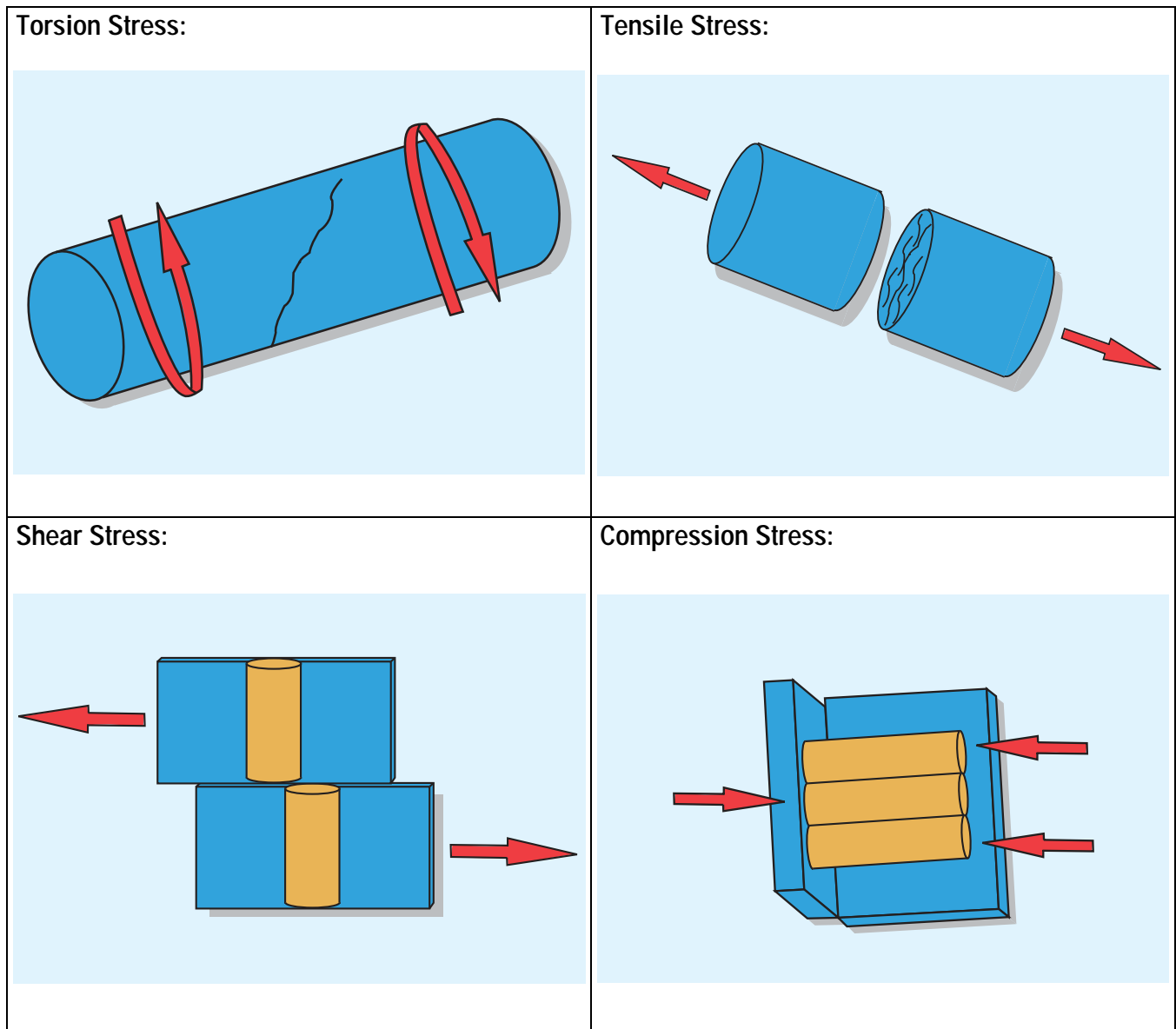

# Glossary and Nomenclature

## Gear Tooth Nomenclature

Tooth Identification:

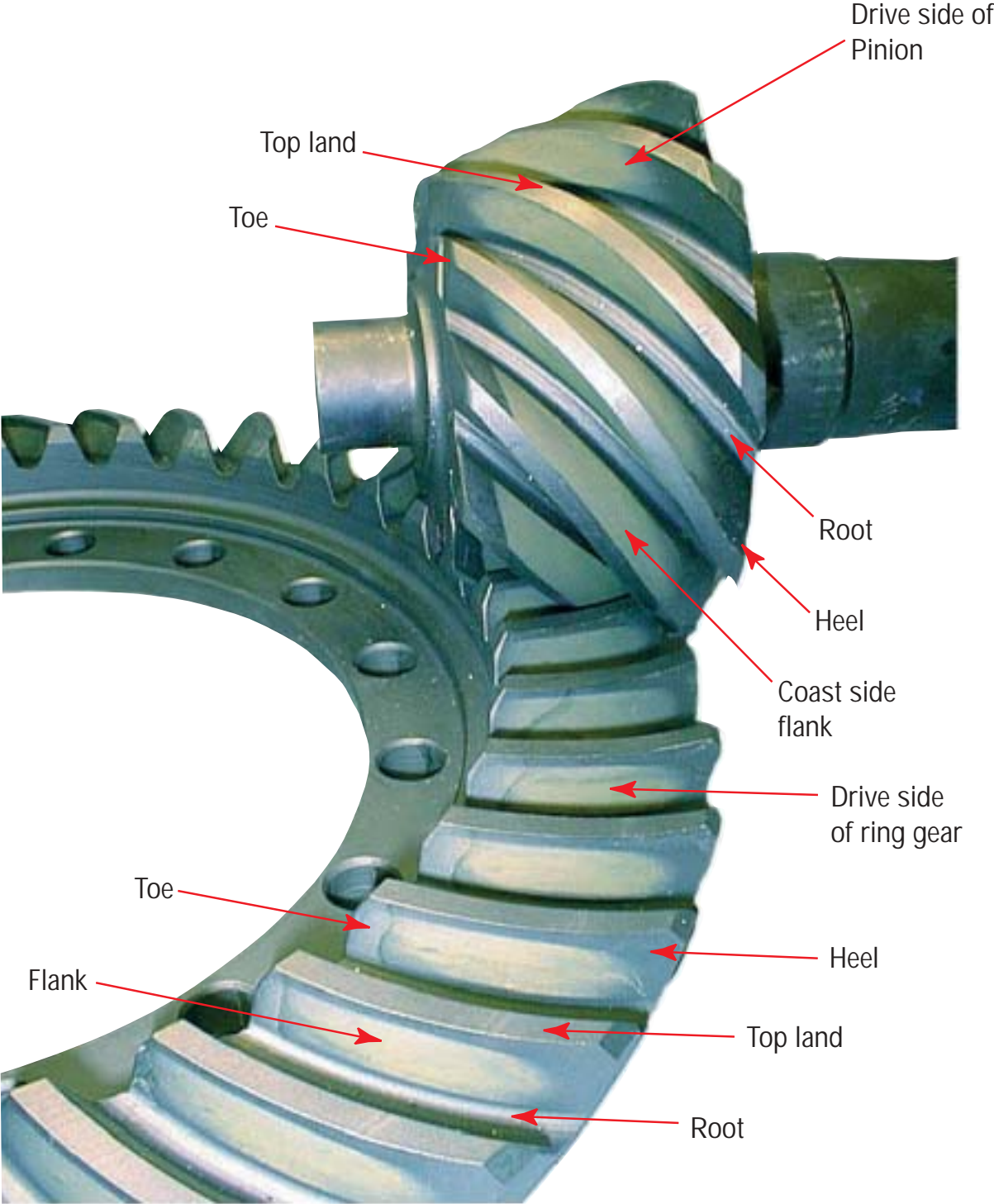

# Glossary and Nomenclature

## Primary Gearing Nomenclature

**Ring and Pinion Identification** - To aid in identifying gear sets, both parts are stamped with information such as number of pinion and ring gear teeth, individual part numbers, and match set numbers.

**Reminder-** The ring and pinion are a matched set and must be replaced together.

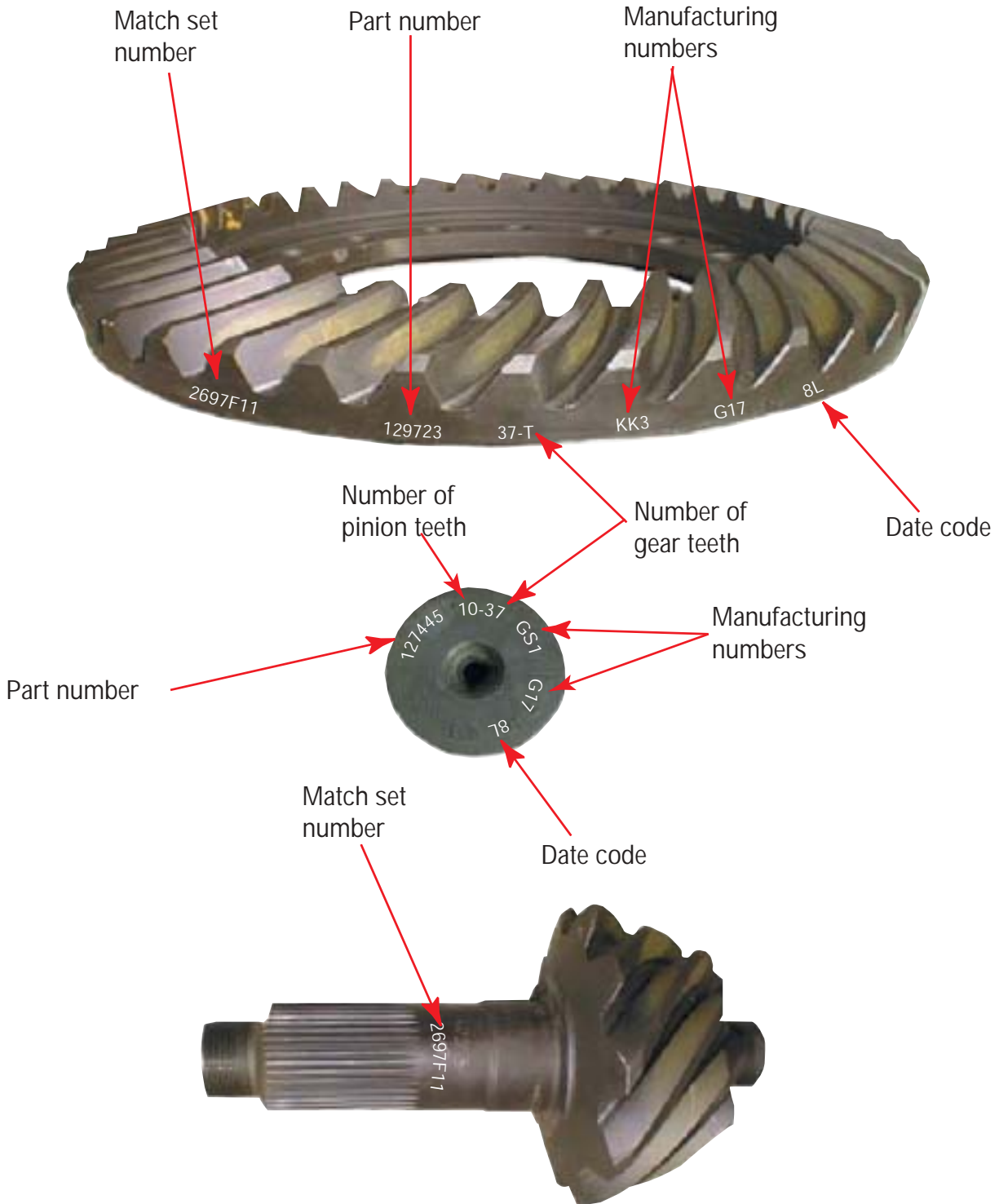

# Glossary and Nomenclature

## Front Drive Axle Nomenclature

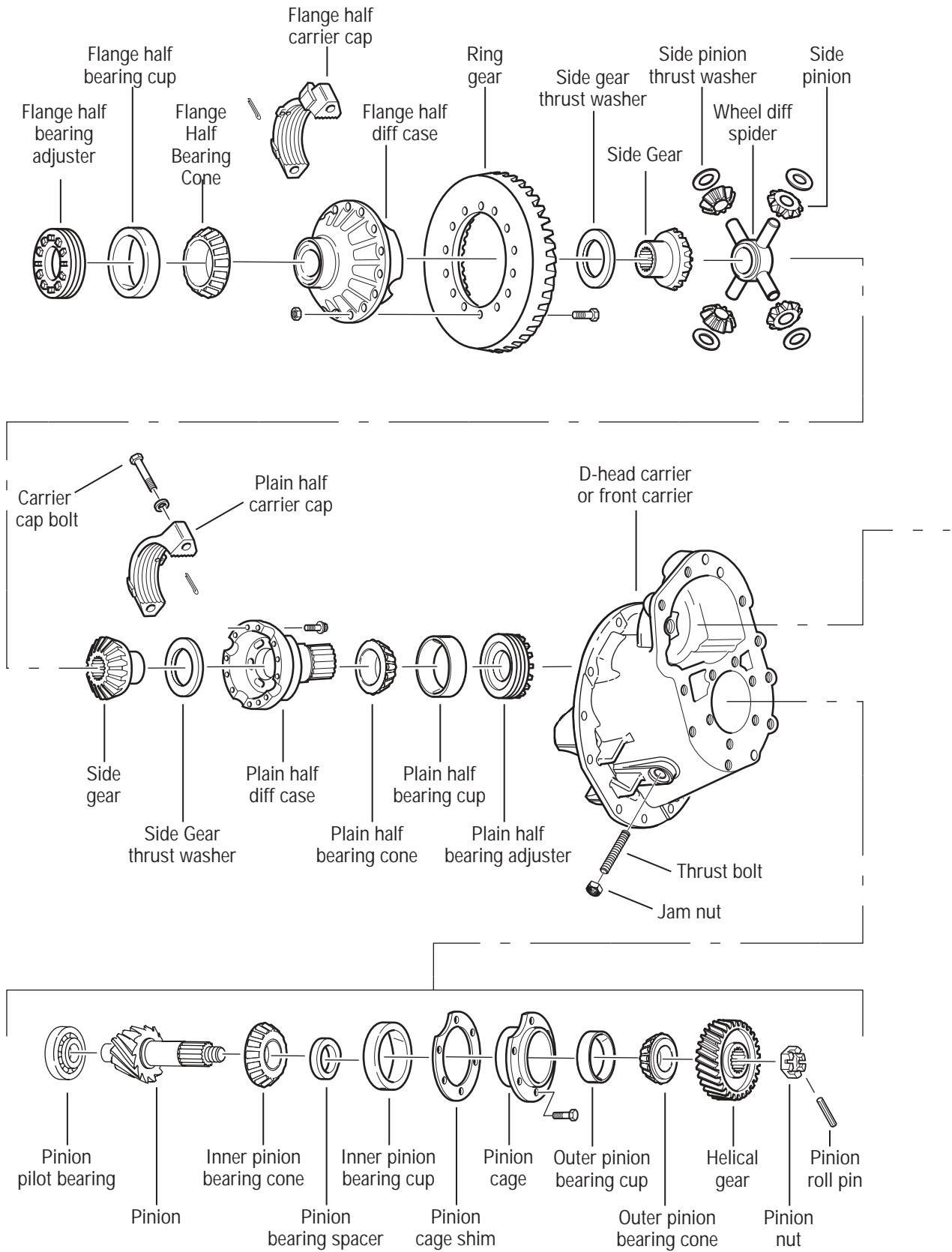

# Glossary and Nomenclature

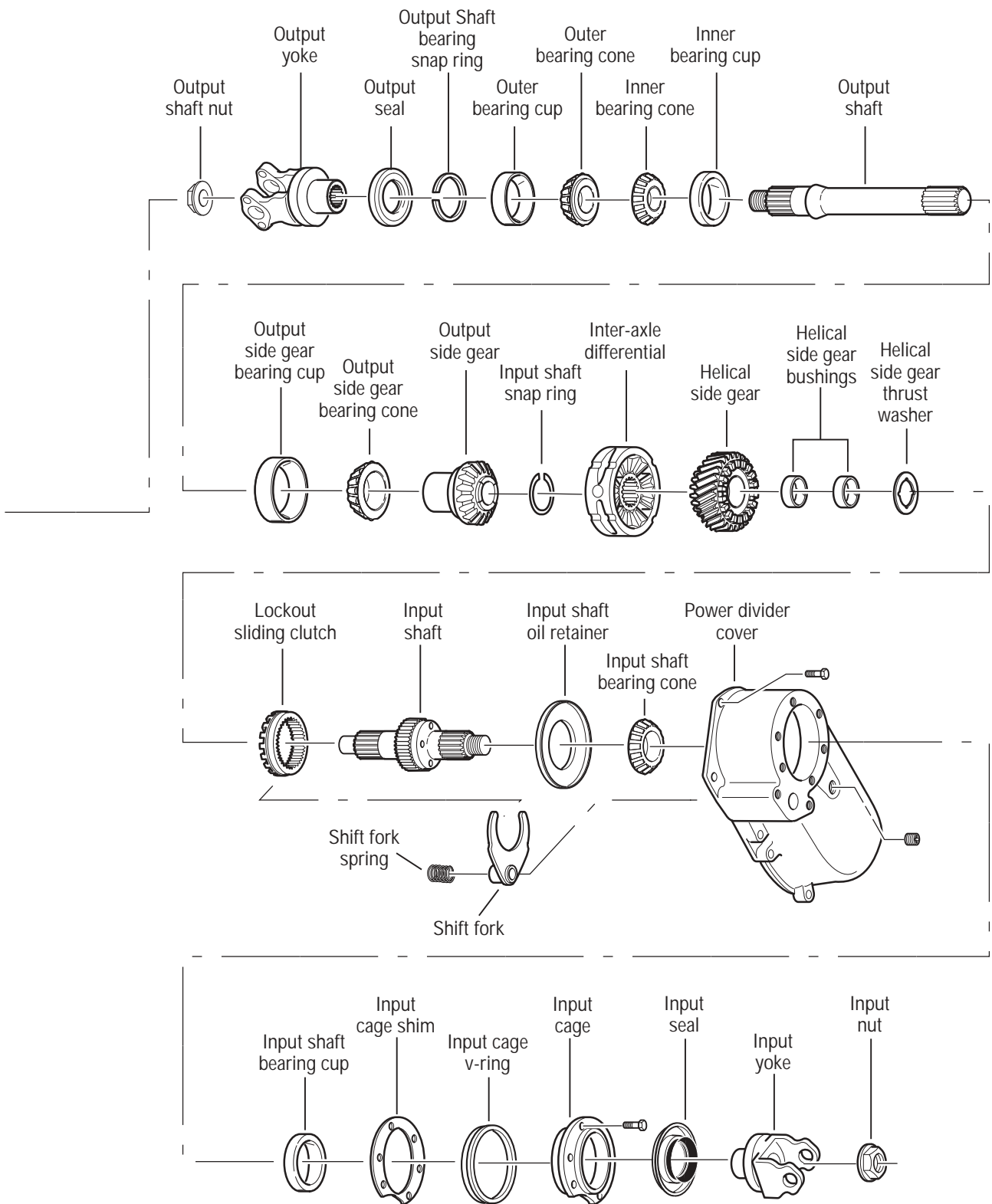

# Glossary and Nomenclature

## Rear Drive Axle Nomenclature

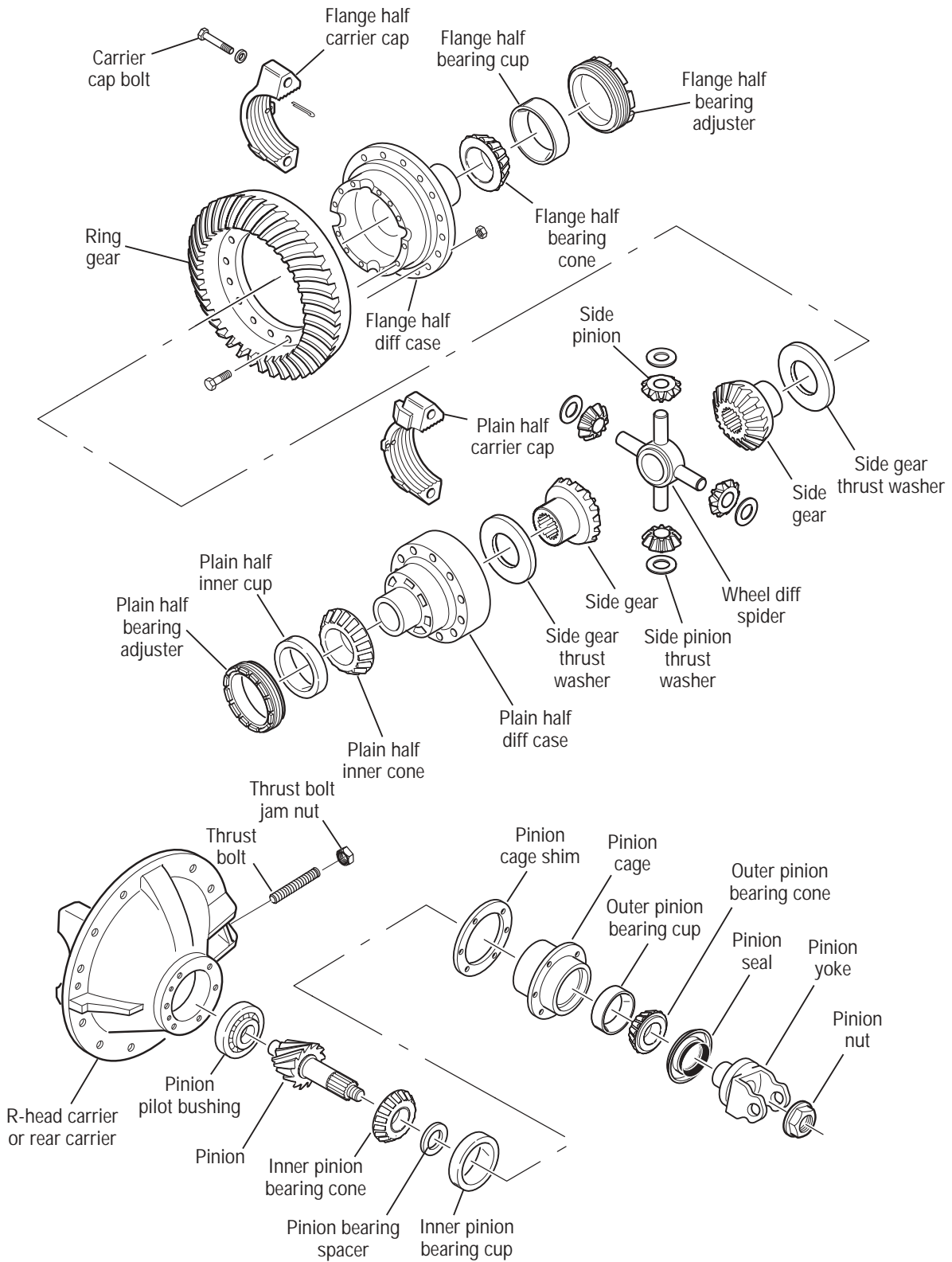



# Glossary and Nomenclature

## Parts Identification

CUST. PART NO. - OEM Part Number

SERIAL NO. - Assembly Number

RATIO - Axle Ratio

SPEC. - Special OEM Request

MODEL - Axle Model

Part NO. - Spicer Part Number

## Tag Locations:

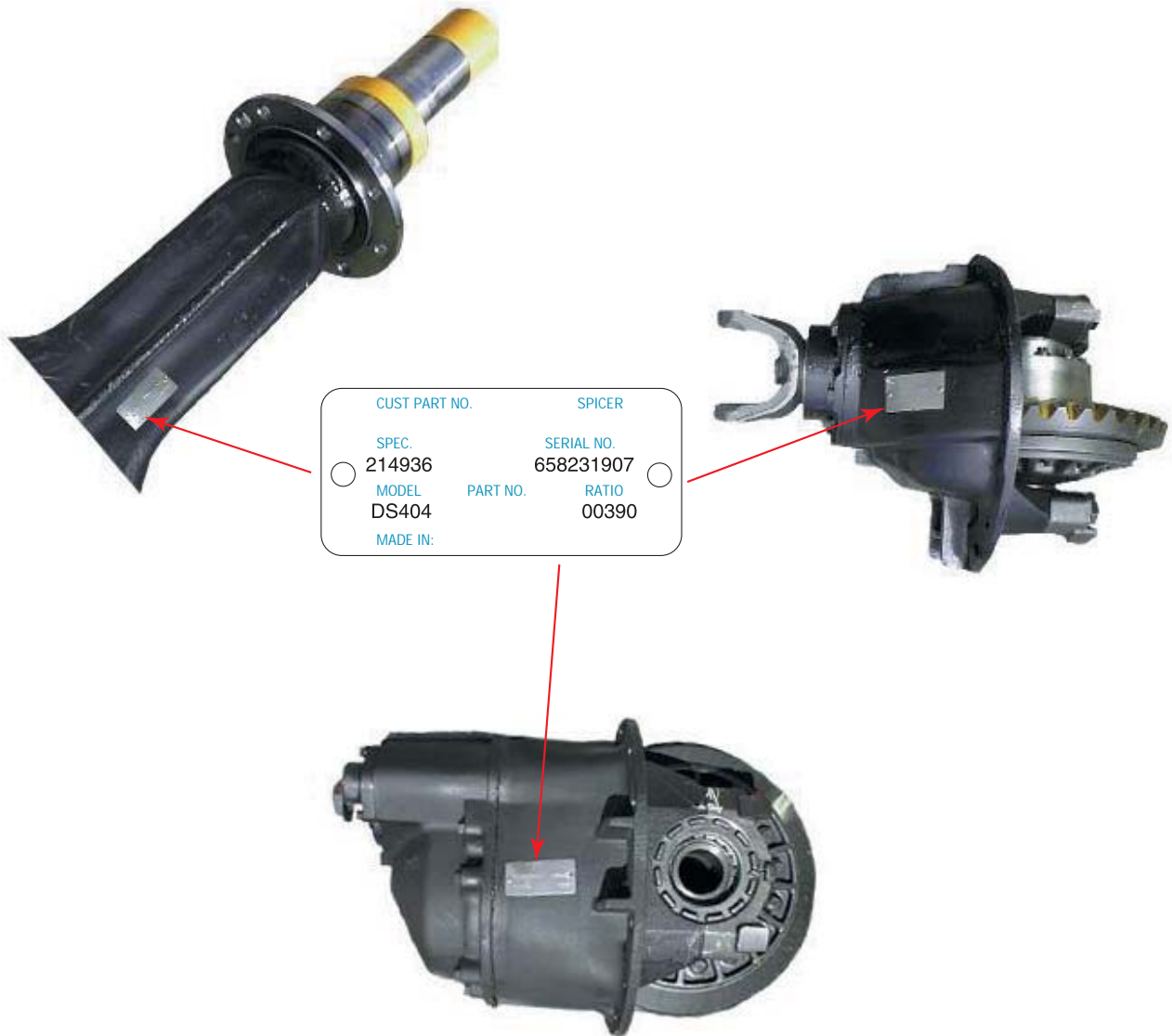

# Gearing and Torque Distribution

## Power Flow

For technical reference, this section describes and illustrates the way power flows through an axle under different gearing and differential configurations.

## Single Speed Power Flow and Torque Distribution

### Inter-axle Differential is Operating

Torque (power flow) from the vehicle driveline is transmitted to the input shaft and the inter-axle differential spider. At this point, the differential distributes torque equally to both axles.

For the forward axle, torque is transmitted from the helical-side gear to the pinion helical gear, drive pinion, ring gear, wheel differential, and axle shafts.

For the rear axle, torque is transmitted from the output shaft side gear, through the output shaft to the inter-axle driveline, to the drive pinion, ring gear, wheel differential, and axle shafts.

### Torque Distribution - Lockout Disengaged:

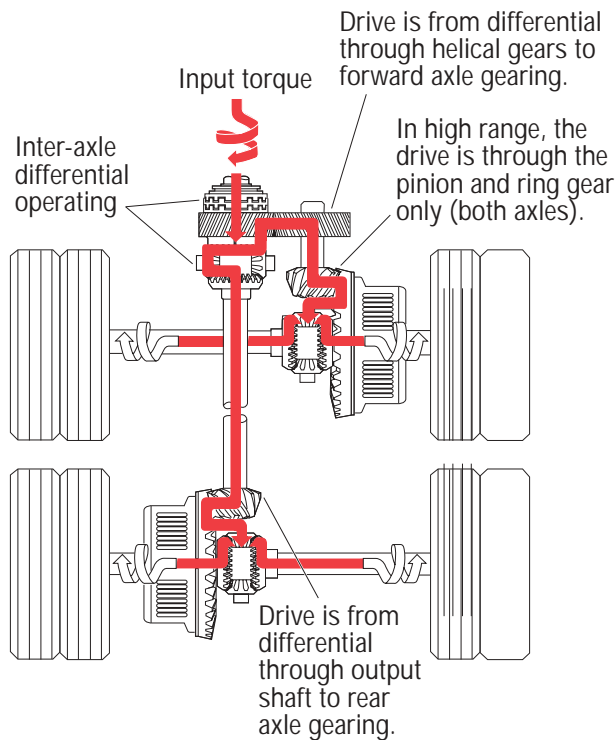

Torque is transmitted to both axes through inter-axle differential action.

**Lockout Disengaged**

### Torque Distribution - Lockout Engaged:

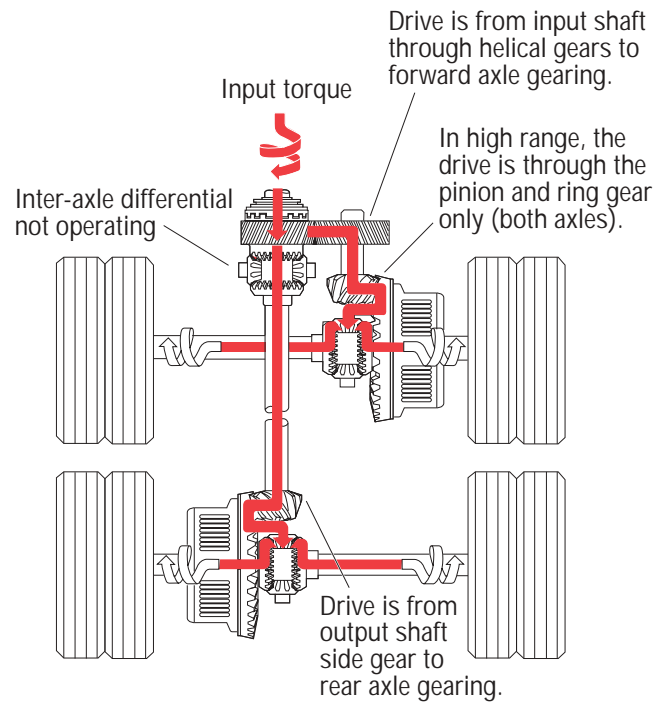

Torque is transmitted to both axes without inter-axle differential action.

**Lockout Engaged**

# Gearing and Torque Distribution

## Spin-out Combinations

Spin-out is a term used to describe excessive differential action. Wheel differential spinout occurs when one wheel remains stationary while the other spins. Inter-axle spinout occurs when either one wheel or one axle spins while the opposing wheel remains stationary.

These figures illustrate some of the spin-out combinations that can cause spinout failure.

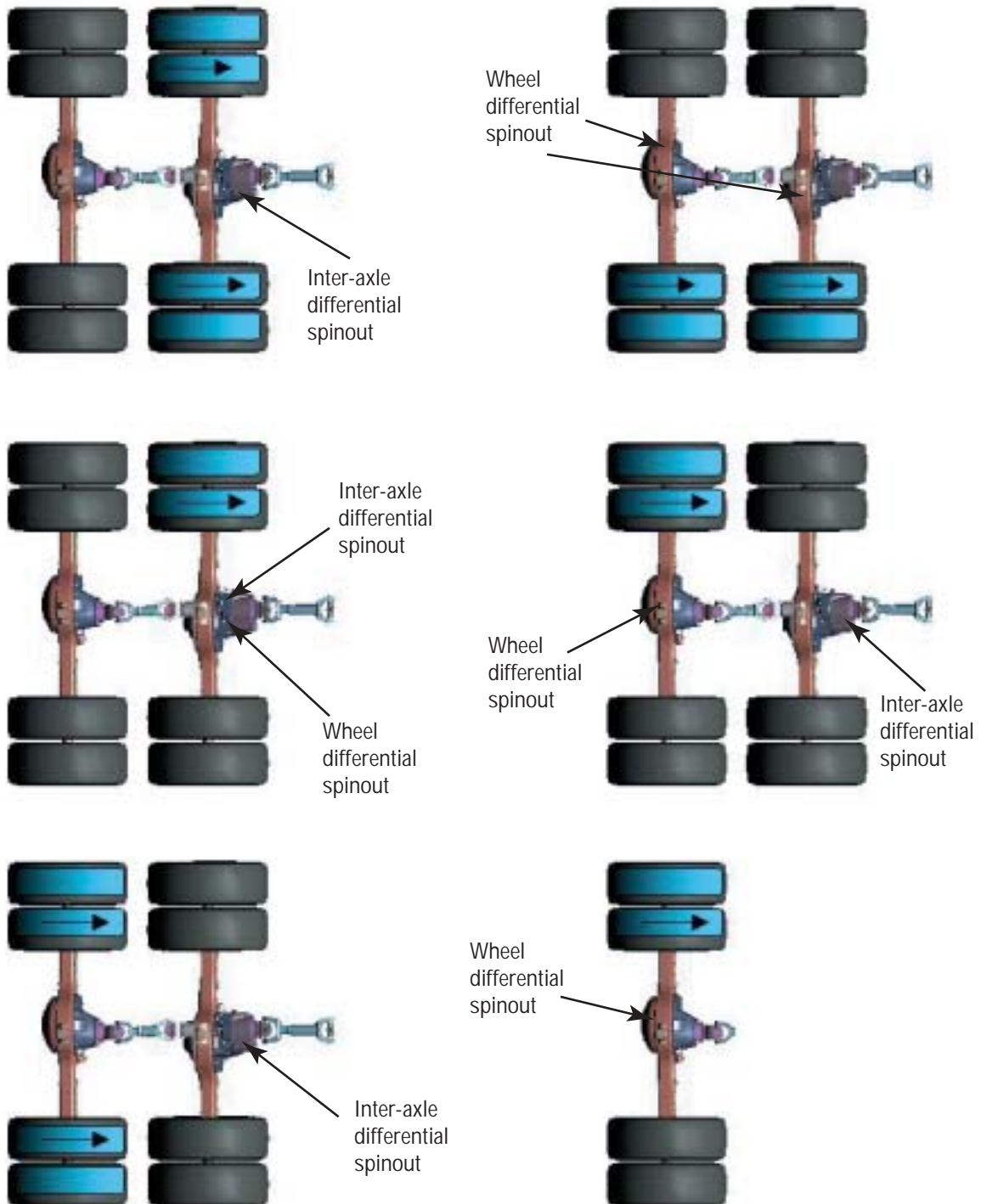

# Failure Analysis

---

## How to Diagnose a Failure

Failure analysis is the process of determining the original cause of a component failure in order to keep it from happening again. Too often, when a failed component is replaced without determining its cause, there will be a recurring failure. If a carrier housing is opened, revealing a ring gear with a broken tooth, it is not enough to settle on the broken tooth as the cause of the carrier failure. Other parts of the carrier must be examined. For a thorough understanding of the failure and possible insight into related problems, the technician needs to observe the overall condition of the vehicle.

No one benefits when a failed component goes on the junk pile with the cause unknown. Nothing is more disturbing to a customer than a repeat failure. Systematically analyzing a failure to prevent a repeat occurrence assures quality service by avoiding unnecessary downtime and further expense to the customer.

The true cause of a failure can be better determined by knowing what to look for, determining how a piece of the equipment was running, and learning about previous problems. In some cases, the part itself is at fault. In the case of a rebuilt rear axle, mismatched gears may have been installed.

The more successful shops prevent repeat equipment failures by developing good failure analysis practices. Knowing how to diagnose the cause of a premature failure is one of the prerequisites of a good heavy-equipment technician.

The following five steps are an effective approach to good failure diagnostics:

1. Document the problem.
2. Make a preliminary investigation.
3. Prepare the parts for inspection.
4. Find the cause of the failure.
5. Correct the cause of the problem.

## Document the Problem

Here are some guidelines for starting to learn about a failure, including questions to ask:

- Talk to the operator of the truck.
- Look at the service records.
- Find out when the truck was last serviced.
- Ask: In what type of service is the truck being used?
- Ask: Has this particular failure occurred before?
- Ask: How was the truck working prior to the failure?

You need to be a good listener. Sometimes, insignificant or unrelated symptoms can point to the cause of the failure.

- Ask: Was the vehicle operating at normal temperatures?
- Ask: Were the gauges showing normal ranges of operation?
- Ask: Was there any unusual noise or vibration?

After listening, review the previous repair and maintenance records. If there is more than one driver, talk to all of them and compare their observations for consistency with the service and maintenance records. Verify the chassis Vehicle Identification Number (VIN) number from the vehicle identification plate, as well as the mileage and hours on the vehicle.

## Make a Preliminary Investigation

These steps consist of external inspections and observations that will be valuable when combined with the results of the parts examination.

- Look for leaks, cracks or other damage that can point to the cause of the failure.
- Make note of obvious leaks around plugs and seals. A missing fill or drain plug would be an obvious cause for concern.
- Look for cracks in the carrier housing (harder to see, but sometimes visible).
- Does the general mechanical condition of the vehicle indicate proper maintenance or are there signs of neglect?
- Are the tires in good condition and do the sizes match?
- If equipped with a torque-limiting device, is it working properly?

During the preliminary investigation, write down anything out of the ordinary for later reference. Items that appear insignificant now may take on more importance when the subassemblies are torn down.

## Prepare the Parts for Inspection

After the preliminary investigation, locate the failure and prepare the part for examination. In carrier failure analysis, it may be necessary to disassemble the unit.

- When disassembling subassemblies and parts, do not clean the parts immediately since cleaning may destroy some of the evidence.
- When tearing down the rear axle, do it in the recommended manner. Minimize any further damage to the unit.
- Ask more questions when examining the interior of the carrier. Does the lubricant meet the manufacturer specifications regarding quality, quantity, and viscosity? As soon as you have located the failed part, take time to analyze the data.

## Find the Cause of the Failure

Here begins the real challenge to determine the exact cause of the failure. Keep in mind that there is no benefit to replacing a failed part without determining the cause of the failure. For example, after examining a failed part and finding that the failure is caused by a lack of lubrication, you must determine if there was an external leak. Obviously, if there is an external leak, just replacing the failed gear is not going to correct the situation.

Another important consideration is to determine the specific type of failure which can be a valuable indicator for the cause of failure. The following pages show different types of failures and possible causes. Use this as a guide in determining types of failures and in correcting problems.

## Correct the Cause of the Problem

Once the cause of the problem has been determined, refer to the appropriate Service Manual to perform the repairs.

# Ring Gear and Pinion

## Shock (Impact) Failure

Ring Gear - Catastrophic Failure



Ring Gear - Coast Side Shock Failure

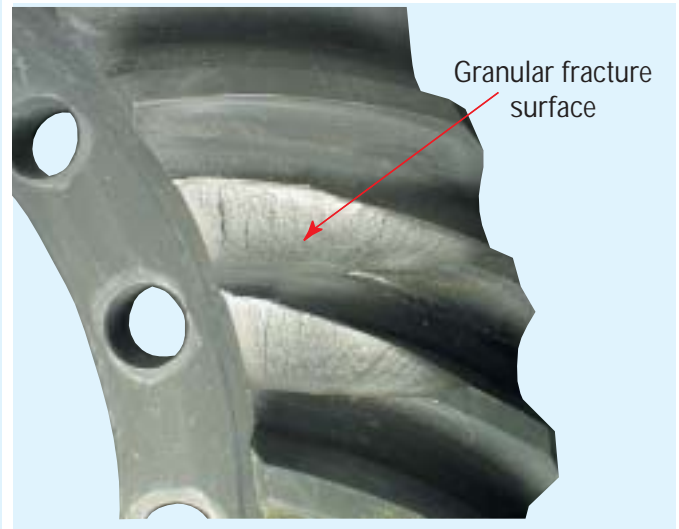

Drive Pinion - Torsional Shock Failure



Drive Pinion - Tooth Shock Load Failure

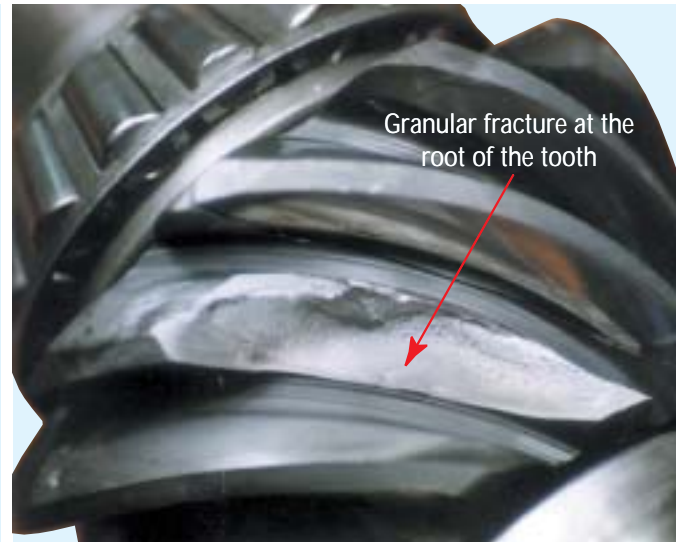

**General Description:** Shock damage occurs from overstressing the gear teeth or shaft beyond the strength of the material. The failure could be immediate (from a sudden shock) or progressive (cracking of the teeth or shaft surface following the initial shock).

- Usual Causes:**
- Rough trailer hook-up
  - Spinning wheels grabbing on firm road surface
  - Misuse of the inter-axle differential lockouts
  - Trying to free-up frozen brakes

**Failure Prevention:** Vehicle Operation and Drive practices - see Failure Prevention Section.

# Ring Gear and Pinion

## Fatigue Failure

Ring Gear - Catastrophic Fatigue Failure

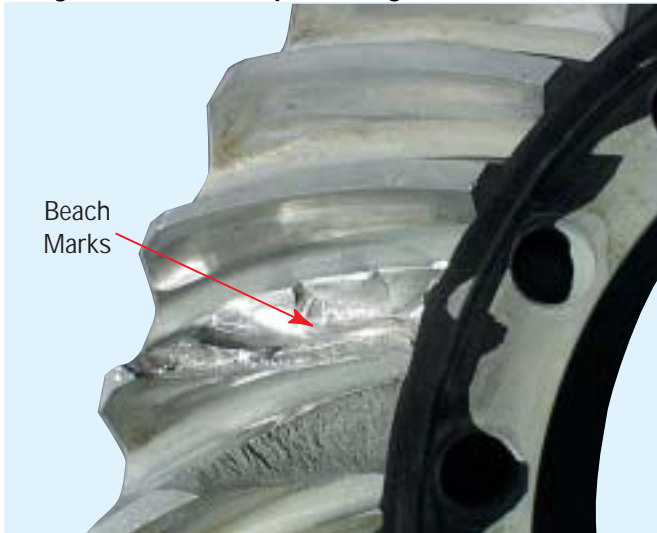

Ring Gear - Start of a Fatigue Failure

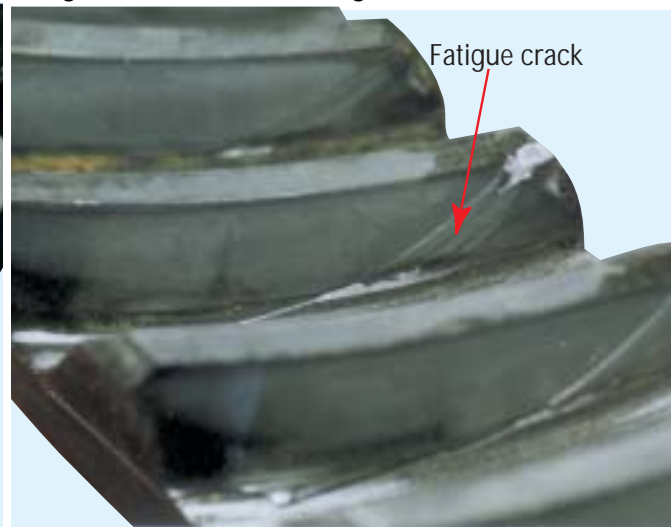

Drive Pinion - Torsional Fatigue Failure



Drive Pinion - Tooth Fatigue Failure

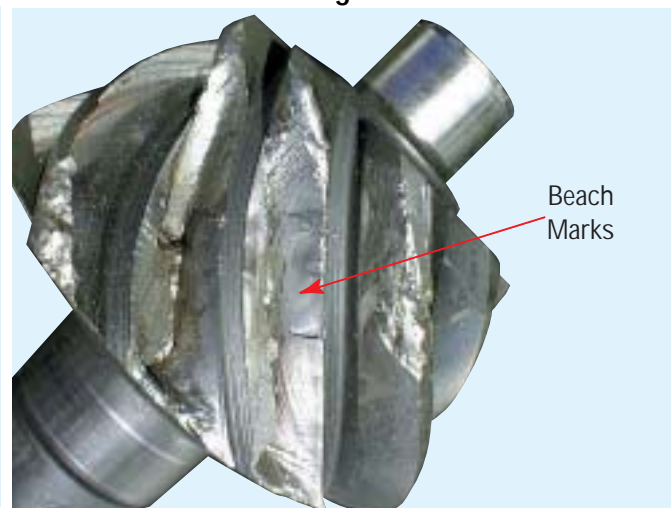

**General Description:** Progressive destruction of a shaft or gear teeth. Extremely high rotating and bending forces produce the initial crack. The crack progresses to the center of the core resulting in complete failure.

**Usual Causes:**

- Overloading the vehicle beyond rated capacity
- Abusive operation over rough terrain

**Failure Prevention:**

- Correct Specifications - see Failure Prevention Section
- Torque is Important - see Failure Prevention Section
- Vehicle Load Ratings - see Failure Prevention Section
- Drive Practices and Vehicle Operation - see Failure Prevention Section

# Ring Gear and Pinion

## Pitting and Spalling Failures

Ring Gear - Pitting

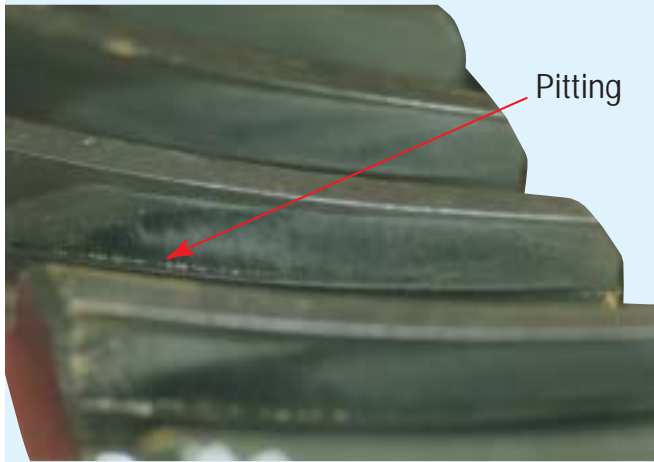

Drive Pinion - Pitting

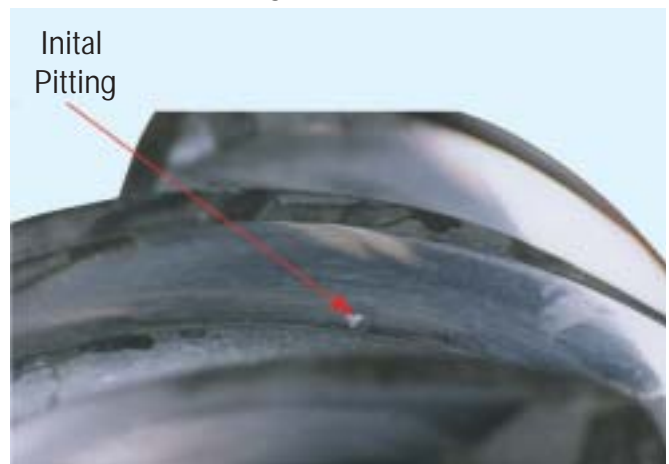

Drive Pinion - Spalling



Drive Pinion - Spalling



**General Description:** Progressive destruction of gear teeth. An overload puts pressure between the meshed surfaces. Repeated overloads result in teeth failure.

**Usual Causes:**

- Continuous overloading
- Contaminated lube
- Incorrect lube
- Low lube levels

**Failure Prevention:**

- Correct Specifications - see Failure Prevention Section
- Torque is Important - see Failure Prevention Section
- Vehicle Load Ratings - see Failure Prevention Section
- Maintenance, Rebuilding, and Adjustment - see Failure Prevention Section



# Ring Gear and Pinion

## Lubrication Failures

Ring Gear - Lubrication Breakdown



Drive Pinion - Lubrication Breakdown

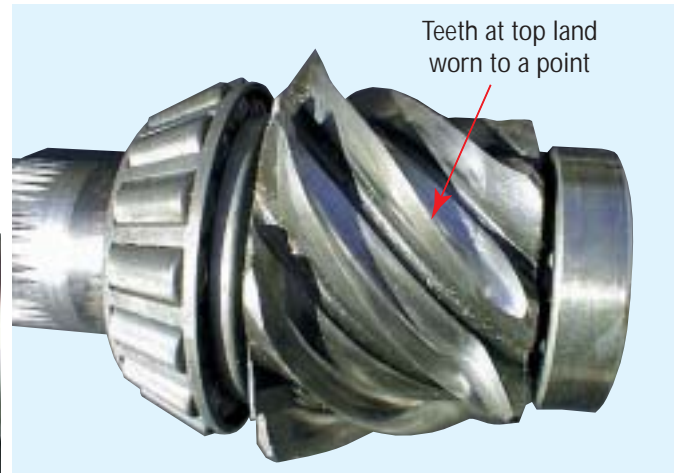

Ring Gear - Low Lube - Crows Foot

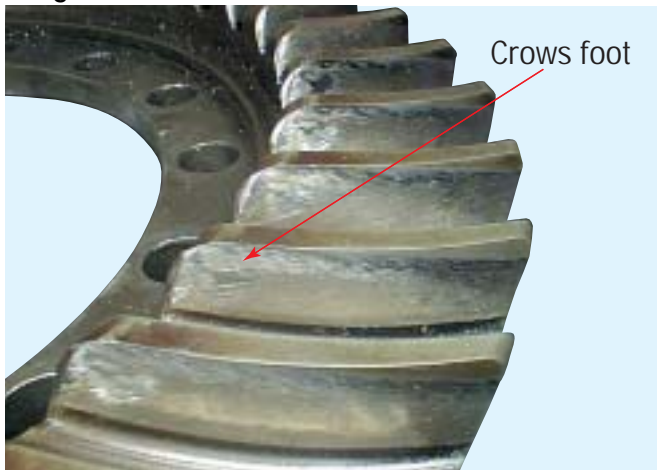

Drive Pinion - Low Lube - Scoring



- General Description and Usual Causes:**
- **Incorrect lube (wrong viscosity or wrong lube type):** Will reduce the life of bearings, gears, bushings, and thrust washers.
  - **Containment Lube:** Water, foreign material, and normal wear or break-in material can cause etching, scoring, or pitting to the contact surfaces. Foreign material in the lube is abrasive.
  - **Low or no lube:** Will create friction which causes overheating, break-down of the protective film, and finally parts seizure of the surfaces of mating parts.
- Failure Prevention:**
- Maintenance, Rebuilding, and Adjustment - see Failure Prevention Section

# Wheel Differential

## Shock (Impact) Failure

Wheel Differential - Catastrophic Failure



Wheel Diff. Spider - Shock Load

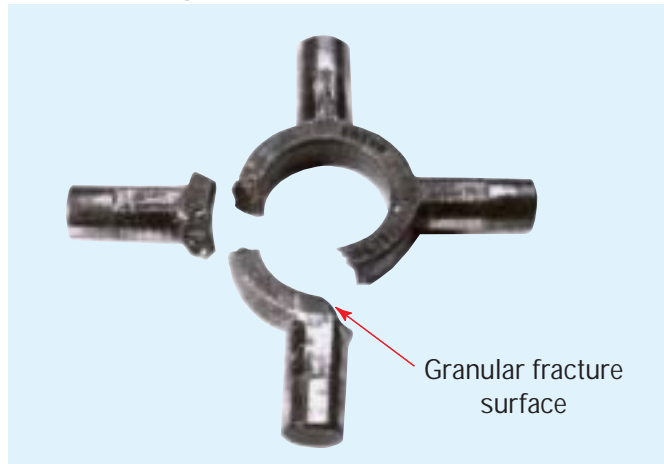

Side Gear - Catastrophic Shock



Side Pinion - Shock Loaded

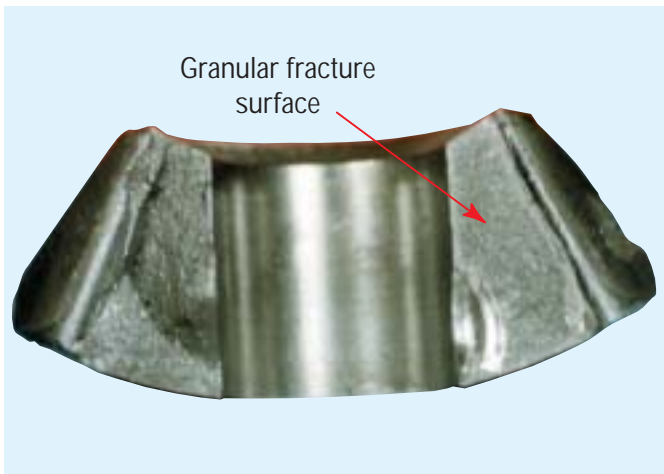

**General Description:** Shock damage occurs from overstressing the gear teeth or spider beyond the strength of the material. The failure can be immediate (as from a sudden shock) or progressive (as cracking of the teeth or shaft surface following the initial shock).

**Usual Causes:**

- Rough trailer hook-up
- Spinning wheels grabbing on firm road surface
- Misuse of the inter-axle differential lockouts

**Failure Prevention:**

- Vehicle Operation and Drive Practices - see Failure Prevention Section

# Wheel Differential

## Spinout - Over Heat Failures

Side Pinion Thrust Washers - Scoring

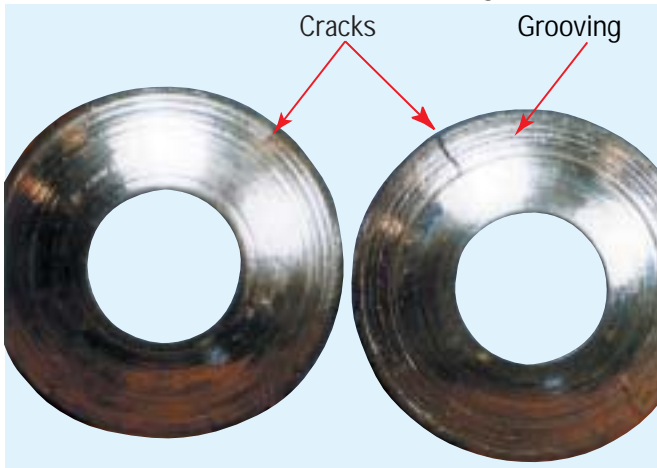

Differential Case - Scoring



Wheel Differential - Catastrophic

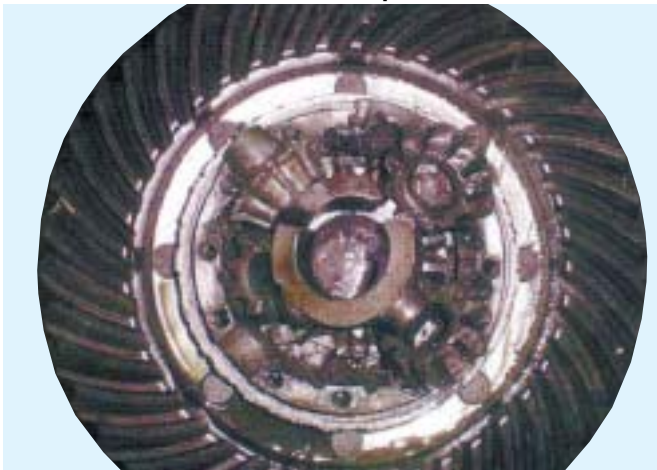

Wheel Diff. Spider Arm - Galling



**General Description:** Spinout is excessive wheel spinning that produces damaging heat. High heat breaks down lube film, allowing damaging metal-to-metal contact. Long-term spinout could produce complete axle breakdown.

**Usual Causes:**

- Main differential spinout occurs when one wheel remains stationary while the other wheel is spinning.

**Failure Prevention:**

- Drive Practices - see Failure Prevention Section

# Power Divider

## Shock (Impact) Failure

IAD Spider - Shock Failure



Spider - Smooth Even Surface - Shock Failure



Sliding Clutch - Shock Failure



Side Pinion Gear - Shock Failure

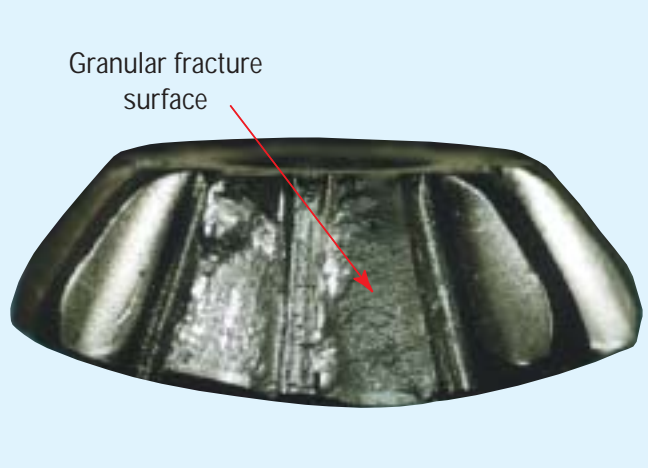

# Power Divider

Helical Side Gear - Shock Failure



Output Side Gear - Shock Failure

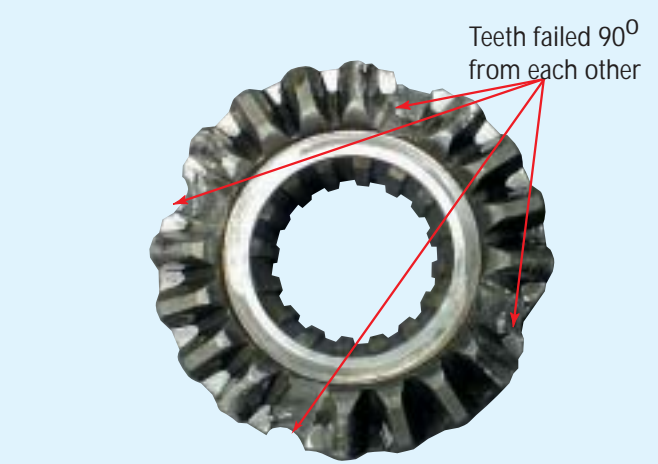

Input Shaft - Torsional Shock Failure



Output Shaft - Torsional Shock Failure



**General Description:** Shock damage occurs from overstressing the gear teeth or shaft beyond the strength of the material. The failure can be immediate (as from a sudden shock) or progressive (as cracking of the teeth or shaft surface following the initial shock).

- Usual Causes:**
- Rough trailer hook-up
  - Rough trailer hook-up
  - Spinning wheels grabbing on firm road surface
  - Misuse of the inter-axle differential lockouts
  - Side stepping the clutch

**Failure Prevention:** • Vehicle Operation and Drive Practices - see Failure Prevention Section

# Power Divider

## Fatigue Failures

Input Shaft - Torsional Fatigue Failure

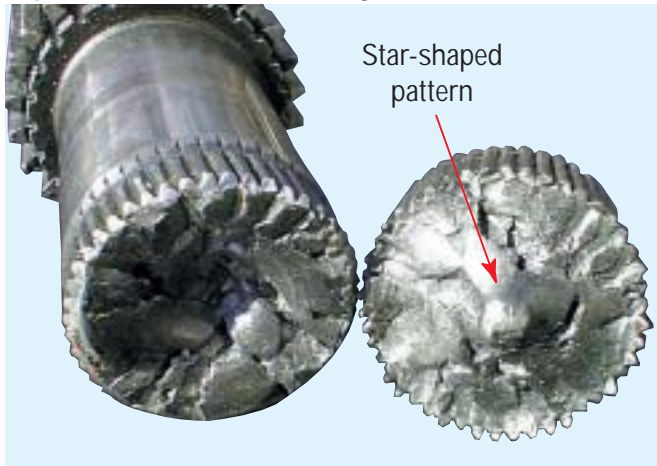

Helical Side Gear - Fatigue Failure

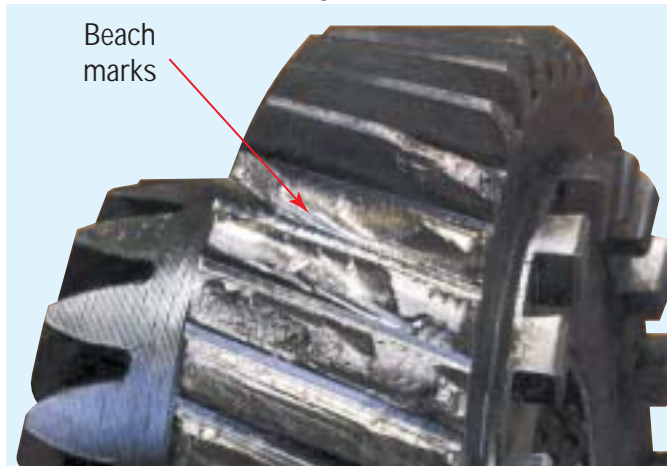

Output Shaft - Torsional Fatigue Failure

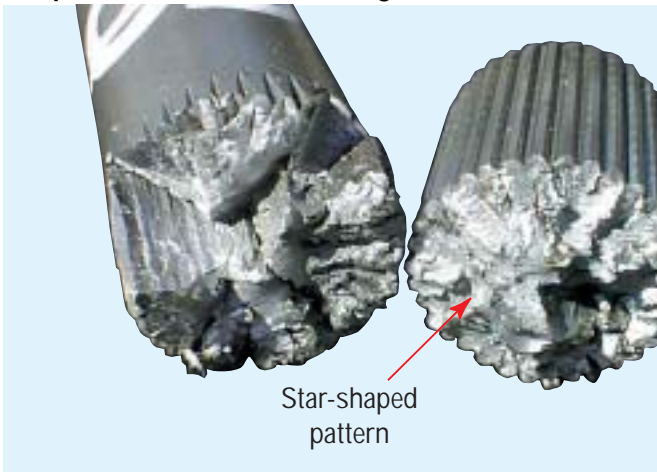

IAD Spider - Fatigue Failure



**General Description:** Progressive destruction of a shaft or gear teeth. A high load causes the initial crack. The crack progresses to the center of the core. Repeated overloads finally cause the shaft to fail.

**Usual Causes:**

- Overloading the vehicle beyond rated capacity
- Abusive operation over rough terrain

**Failure Prevention:**

- Correct Specifications - see Failure Prevention Section
- Torque is Important - see Failure Prevention Section
- Vehicle Load Ratings - see Failure Prevention Section
- Drive Practices and Vehicle Operation - see Failure Prevention Section

## Pitting and Spalling Failures

Helical Side Gear - Pitting

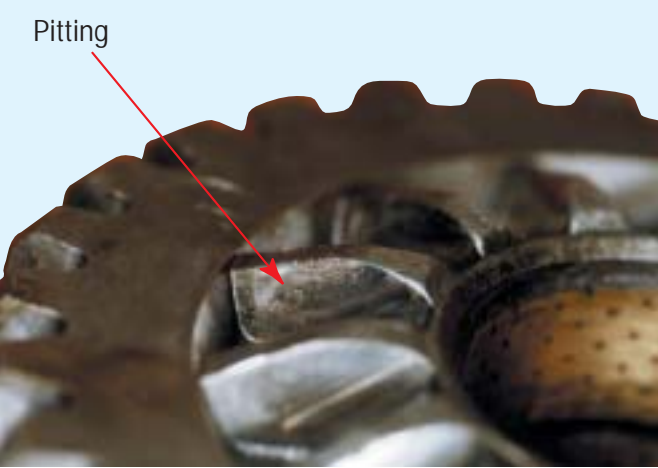

Side Gear - Pitting

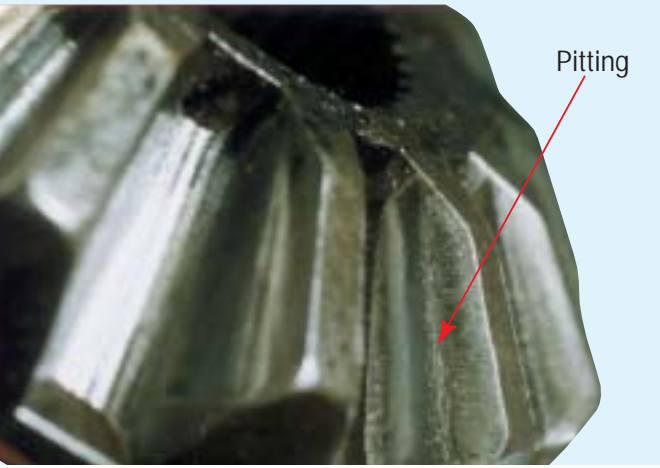

Output Side Gear - Spalling



Side Pinion - Pitting

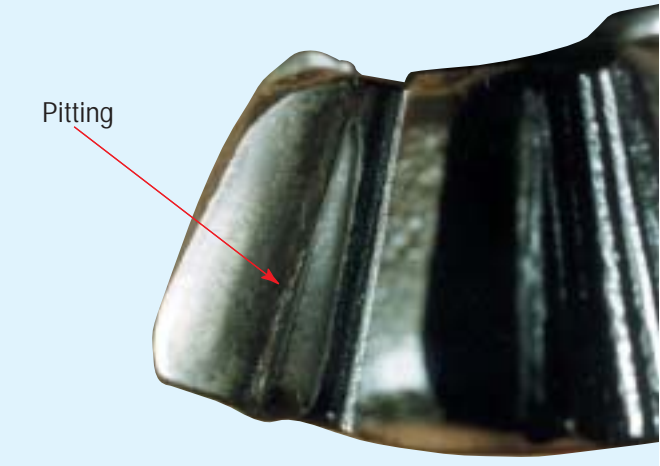

**General Description:** Progressive destruction of gear teeth. An overload puts pressure between the meshed surfaces. Repeated overloads result in teeth failure.

- Usual Causes:**
- Continuous overloading
  - Contaminated lube
  - Incorrect lube
  - Low lube levels

- Failure Prevention:**
- Correct Specifications - see Failure Prevention Section
  - Torque is Important - see Failure Prevention Section
  - Vehicle Load Ratings - see Failure Prevention Section
  - Maintenance, Rebuilding, and Adjustment - see Failure Prevention Section

# Power Divider

## Spinout Failures

Inter-Axle Diff. Assembly - Catastrophic Failure

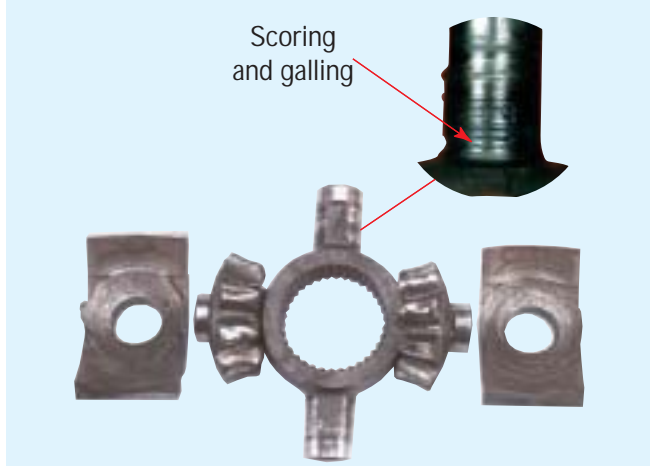

Side Pinion Welded to Spider Arm



IAD Spider Arm - Galling

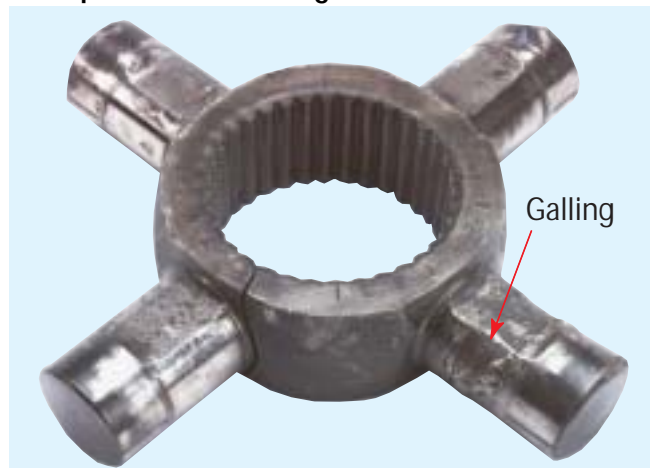

Failed Thrust Washer

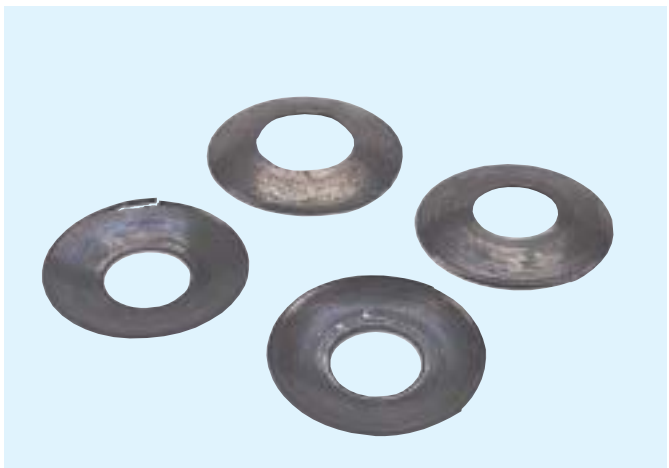



# Power Divider

Input Shaft Assembly - Catastrophic Failure



Input Shaft Stub-End - Galling



Helical Side Gear - Bushing Burn-Up



Output Side Gear - Stub-End Bore Galling

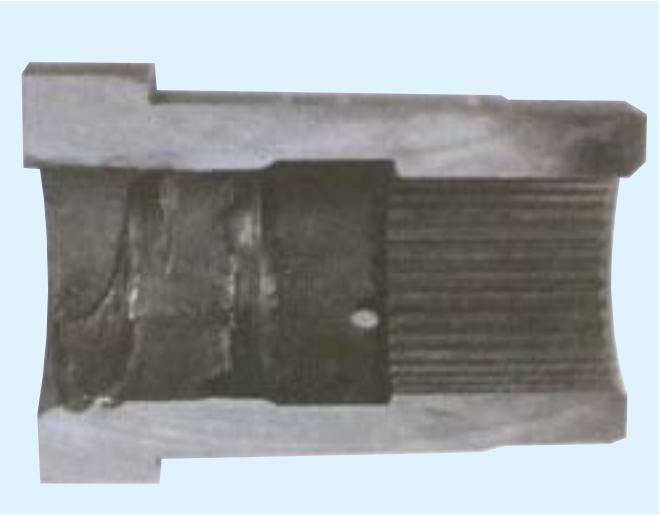

**General Description:** Spinout is excessive wheel spinning that produces damaging heat. High heat breaks down lube film, allowing damaging metal-to-metal contact. Long-term spinout could produce complete axle breakdown.

- Usual Causes:**
- **Single rear axle:** Main differential spinout occurs when one wheel remains stationary while the other wheel is spinning.
  - **Tandem axles:** Spinout occurs in the inter-axle differential when either one wheel or one axle spins while its mate remains stationary

**Failure Prevention:** • Drive Practices and Vehicle Operation - see Failure Prevention Section

# Power Divider

## Lubrication Failures

IAD Shift Fork DS404 - Improper Shifting



IAD Shift Fork DS402 - Improper Shifting

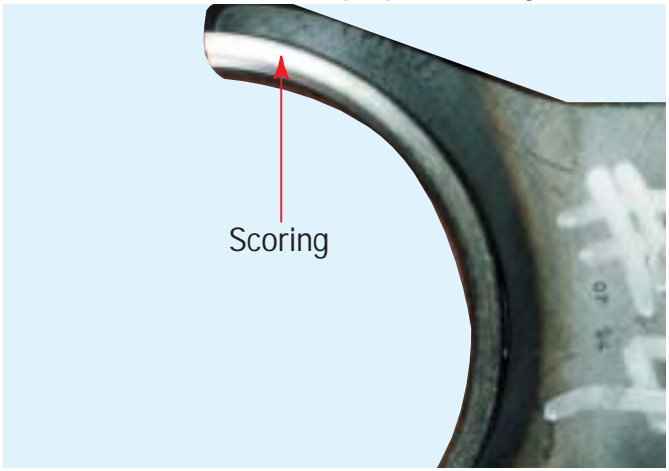

Power Divider Thrust Washer - Lubricant Contamination



Helical Side Gear Bushing - Lubricant Contamination

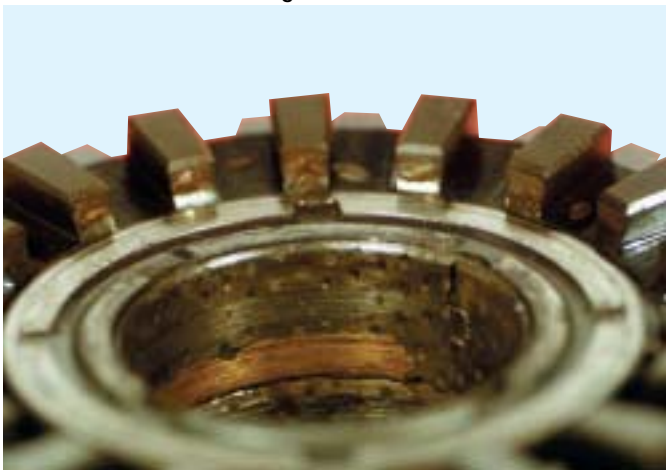

**General Description:** Shift problems, metal-to-metal contact and dirty hot running parts are the result of lubrication breakdown in the Power Divider.

- Usual Causes:**
- Incorrect lube (wrong viscosity or wrong lube type)
  - Improper lube levels
  - Failure to change lube at proper intervals
  - Failure to clean plugs, filters, and strainers periodically

**Failure Prevention:** • Drive Practices - see Failure Prevention Section

## Normal and Contamination Wear

Normal Uneven Wear Pattern - Low Mileage

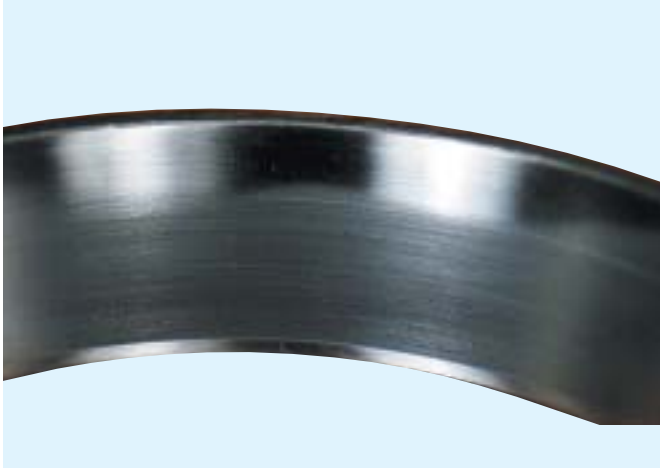

Normal Even Wear Pattern - High Mileage

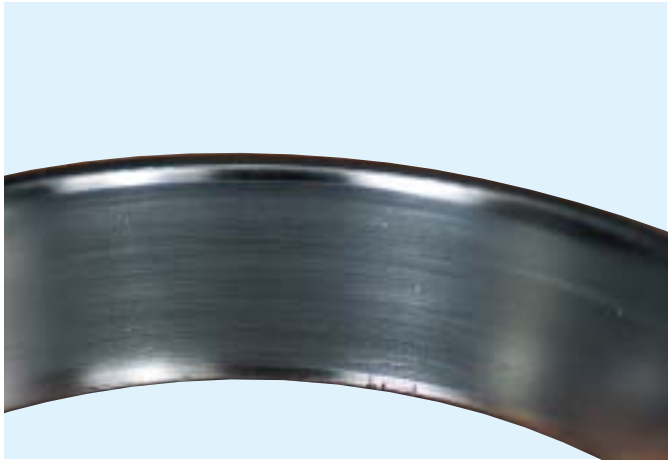

Contamination - Scratching



Contamination - Bruising



- General Description and Usual Causes:**
- **Uneven wear pattern - low mileage:** Uneven wear pattern typical of low mileage and light to moderate loads. It is caused by the bearing preload during assembly and will gradually become more even as mileage increases. If not otherwise damaged, parts showing this wear pattern may be reused.
  - **Even wear pattern - high mileage:** Even wear pattern with light pitting typical of advanced mileage with normal loads. Pitting is caused by contaminants in the lube.
  - **Contamination wear:** Scratching and bruising occur when hard metal particles pass through the lube system. This damage is an early sign of bearing failure. Possible causes include poor lube maintenance and/or overloading the axles.
- Failure Prevention:**
- Maintenance, Rebuilding, and Adjustment - see Failure Prevention Section.

# Bearings

## Pitting and Spalling Damage

Bearing Cup - Pitting

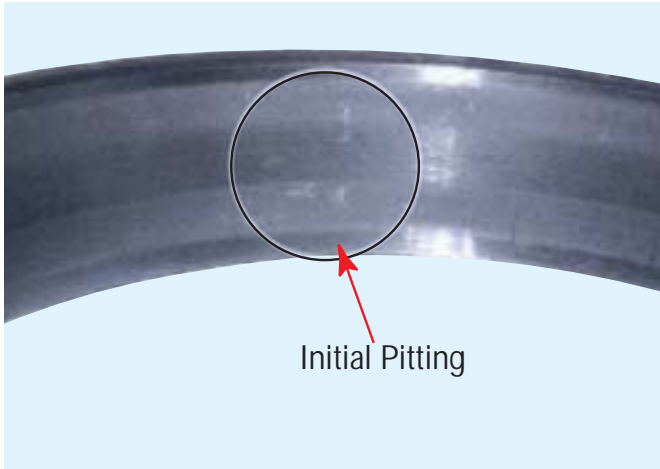

Bearing Cone - Pitting



Bearing Cup - Spalling

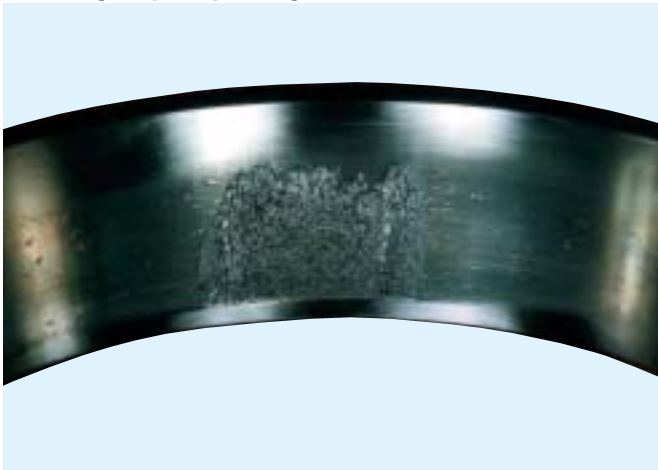

Bearing Cone - Spalling



**General Description:** This failure may start as bruising or denting then progress to frosting, pitting, and finally spalling. As the failure progresses the material flakes away.

**Usual Causes:**

- Hard metal particles in the lubricant
- Consistent overloading in the lubricant

**Failure Prevention:**

- Correct Specifications - see Failure Prevention Section
- Vehicle Load Ratings - see Failure Prevention Section
- Maintenance, Rebuilding, and Adjustment - see Failure Prevention Section

# Seals and Yokes

## Yoke Wear and Seal Lip Wear

Yoke to Seal Interface - Normal Wear

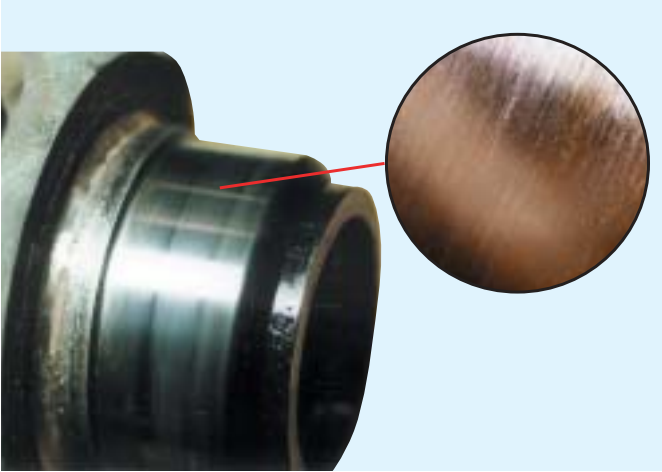

Yoke to Seal Interface - Extreme Wear

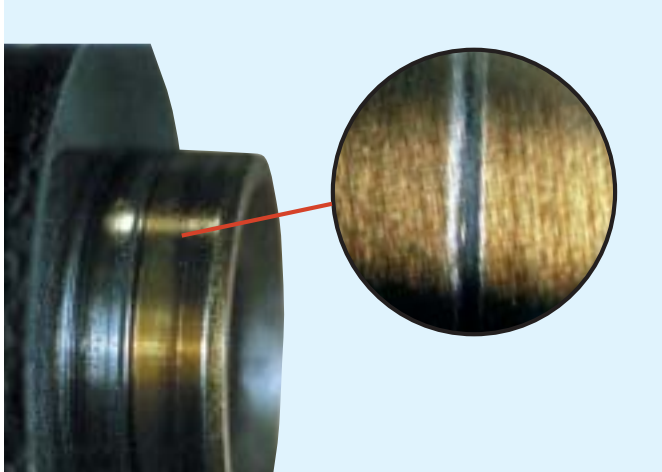

Seal Lip - Normal Wear

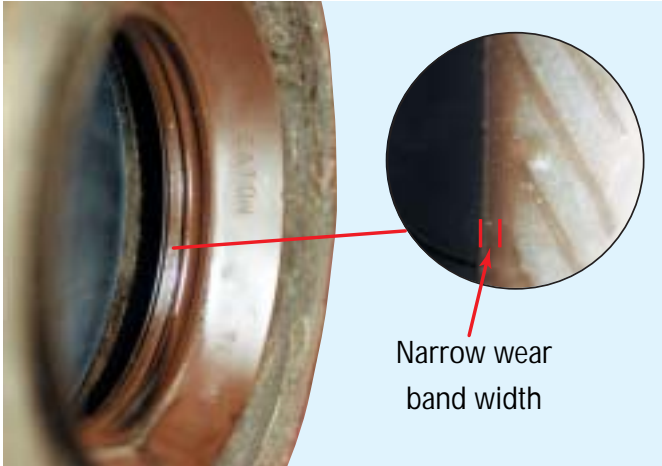

Narrow wear  
band width

Seal Lip - Extreme Wear

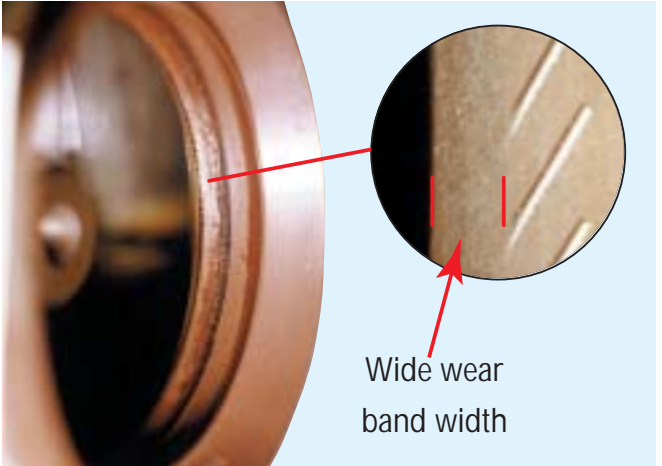

Wide wear  
band width

**General Description and Usual Causes:**

- **Normal Wear:** Flattened Edge - Notice the flattened edge of the seal lip indicating incorrect positioning of seal lip against the yoke. Incorrect placement of seal lip will result in lube leakage from the seal or, as shown above, permit dust or dirt to contaminate the lube itself. In order to retain lube and exclude dust and dirt from the system, the seal must be clean, void of defects, and properly installed.
- **Extreme Wear:** Gap on Seal Lip - Contact area on seal lip is too wide (over 1/32"). This indicates excessive wear or loss of material consistency. The seal must be replaced.
- **Scoring:** If the yoke displays a rough or scored condition, replace the seal and/or yoke.

**Failure Prevention:**

- Maintenance, Rebuilding, and Adjustment - see Failure Prevention Section

Seals and Yokes

# Seals and Yokes

## Installation Problems

Bent Outer Shell - Do Not Reuse

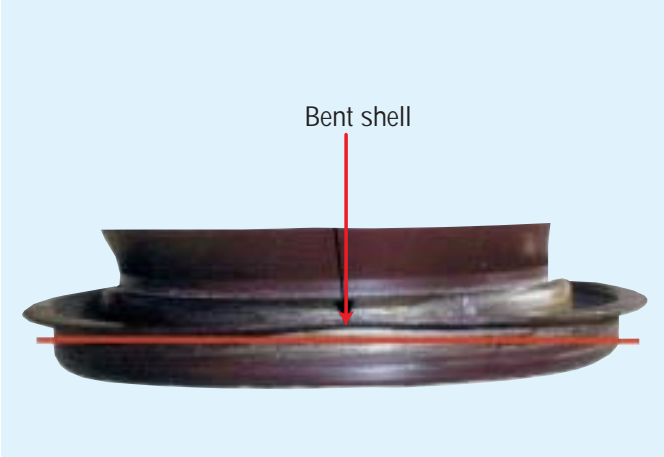

Dirt Between Seal and Bearing Cage



Damaged Seal Lip



Contamination



# Seals and Yokes

---

**General Description:** A seal has two critical functions: to retain lube and to exclude dust and dirt. For proper function, the seal must be correctly installed, clean, and free of defects.

**Seal Inspection:** Careful inspection of seal condition plays an important role in both routine maintenance and failure analysis. Below are some conditions to look for. Check carefully as the smallest defect on the seal lip could cause a leak. In general, any of these observed defects calls for a replacement seal.

- Check for damaged seal lip, bent outer shell, cups and nicks or scoring.
- Examine seal edge. A new seal lip has a sharp edge. If sharp edge is flattened greatly, replace the seal.
- Check for hardness or a brittle or cracked lip. This condition is usually caused by excessive temperatures. If the seal lip area is not flexible, replace it.
- Check seal lip contact area. If the contact area is over 1/32", the seal may be excessively worn or the material may have lost its consistency.
- Look for bonding separation of seal to outer shell. This could change the flexibility of the seal lip and cause a leak.
- Check seal spring for fit of the seal on the yoke or low tension. The seal lip may have lost its tension or consistency. Replace it.
- Check inside, under the seal lip, and the casing, for dirt between seal and bearing cage or an accumulation of sludge and other contamination. The seal must be as clean as possible and void of foreign contaminants.

**Note:** Reference Seal Maintenance Guide TCSM-0912.

# Axle Shafts

## Shock and Fatigue Failure

Axle Shaft - Torsional Shock Failure



Torsional Shock Failure - Close up

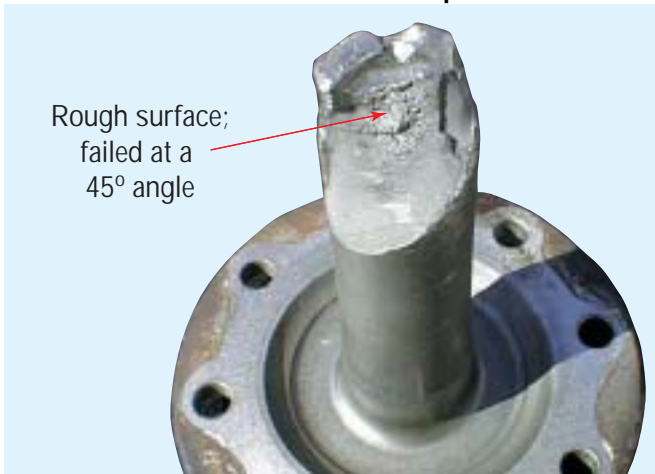

Axle Shaft - Torsional Fatigue Failure



**General Description:** Shock damage occurs from overstressing the shaft beyond the strength of the material. The failure can be immediate (as from a sudden shock) or progressive (as cracking of the shaft surface following the initial shock).

**Usual Causes:**

- Rough trailer hook-up
- Spinning wheels grabbing on firm road surface
- Misuse of the inter-axle differential lockouts

**Failure Prevention:**

- Vehicle Operation - see Failure Prevention Section



# Drive Axle Housing

## Spindle Damage and Fatigue Cracks

### Spindle Damage

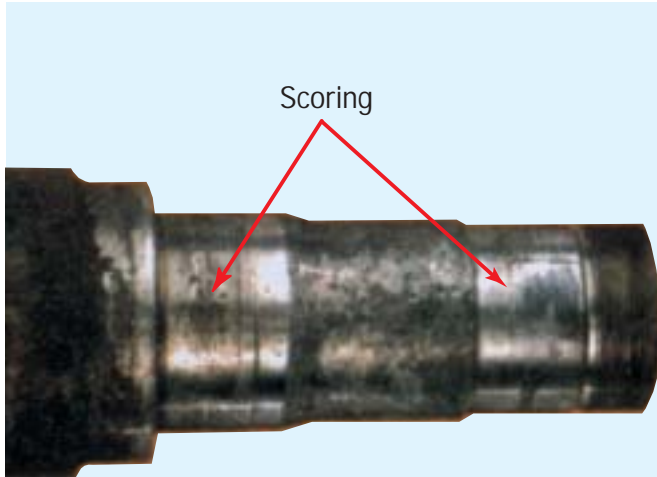

### Fatigue Cracks

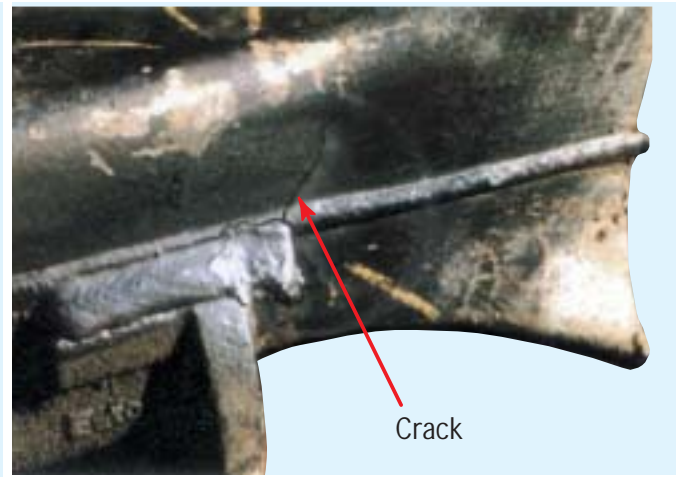

**General Description:**

- **Spindle Damage:** Worn and scored bearing mounting surfaces, seized bearings, or loose adjustments result from a lube deficiency.

- **Fatigue Crack:** Cracking starts at the bracket weld and extends along the lines. The failure is generally caused by induced repetitive loads at the bracket mounting surface during operation. The basic cause of these cracks could be misapplication, material, or weld problems. Another indicator of a cracked condition could be a wet spot caused by lube leakage. When this condition does exist, replace the housing.

**Usual Causes:**

- Contamination
- Lack of Lube
- Load misapplication
- Weld Problems

**Failure Prevention:**

- Maintenance, Rebuilding, and Adjustment - see Failure Prevention Section.

# Drive Axle Housing

---

## Loose or Over-Torqued Hardware

Loose Clamping Hardware



Over-torqued Clamping Hardware



**General Description:** Sufficient clamp load at the spring pad area is important to keep the joint tight. Loose clamping or over-torqued clamping hardware resulting in cracks in the drive axle housing.

**Usual Causes:**

- Non-OEM specified clamping hardware
- Failure to follow OEM torque specifications

**Failure Prevention:**

- Maintenance, Rebuilding, and Adjustment - see Failure Prevention Section

## Bushing Damage - Installation

Improper Kingpin Installation



Improper Reaming



**General Description:** Damaged bushing material, areas of bushing material bunched up or missing, or gouges in bushing material.

**Usual Causes:**

- Improper kingpin installation
- Improper tools used to size bushings (if using reamable bushings)

**Failure Prevention:**

- Use recommended reaming tools. See Dana Service Manual AXSM-0038 (if using reamable bushings)
- Follow assembly procedures found in the Dana Service Manual AXSM-0038

# Steer Axle

## Bushing and Kingpin Wear - Contamination

Bushing - Clogged with Contamination



Kingpin - Grooving from Contamination



Bushing - Lack of Grease



Kingpin - Lack of Grease



**General Description:** Rust, grooving, and scoring to the bushing area of the kingpin, bushings excessively worn, and contamination built up in bushing.

**Usual Causes:**

- Lack of grease (greasing intervals too infrequent)
- Contamination damage (greasing not long enough to flush contaminants from kingpin joint)
- Excessive knuckle vertical play
- Wrong grease type

**Failure Prevention:**

- Grease intervals must be adjusted to match the environment of the vehicle. The more contamination, the more you need to grease.
- Greasing should continue until **clean** grease is seen coming from between the joints.
- Knuckle vertical play should not exceed .040".
- Use #2 lithium grease only.

## Bushing and Kingpin Wear - Normal

Bushing Worn in One Area Only



No Wear on Kingpin



**General Description:** Normal wear to a bushing will show an even wear pattern at one location only. It will be on the outboard side of the top bushing and on the inboard side of the bottom bushing. This wear is indicated by an endplay reading of more than .015".

**Usual Causes:**

- High mileage
- Small amounts of contamination
- High loads over long periods of time

# Two Speed Planetary

## Pitting and Spalling Failures

Sliding Clutch - Pitting

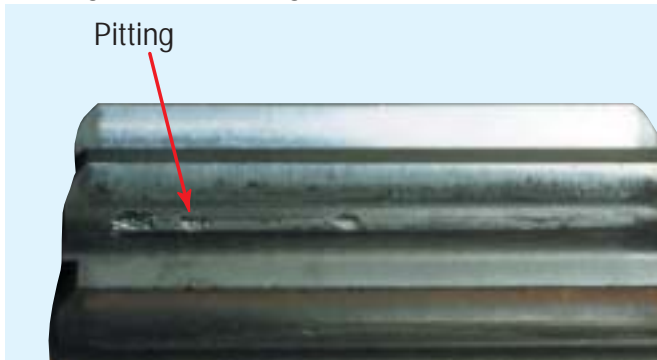

Planetary Gear - Spalling

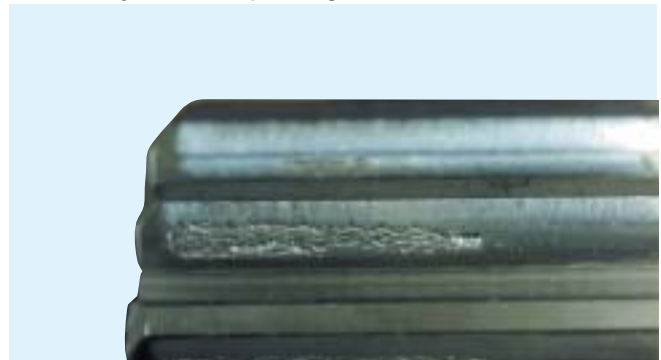

Sliding Clutch - Shock Failure



Planetary Gear - Shock Failure



**General Description:** **Pitting and spalling:** Progressive destruction of gear teeth. An overload puts pressure between the meshed surfaces. Repeated overloads result in teeth failure.

**Shock:** Damage from overstressing the gear teeth or shaft beyond the strength of the material. The failure can be immediate (as from a sudden shock) or progressive (as cracking of the teeth or shaft surface following the initial shock).

**Usual Causes:**

**Pitting and Spalling:**

- Continuous overloading
- Contaminated lube
- Incorrect lube
- Low lube levels

**Shock:**

- Rough trailer hook-up
- Misuse of the lockouts
- Trying to free-up frozen brakes
- Spinning wheels grabbing on firm road surface

**Failure Prevention:**

- Vehicle Operation and Drive Practices - see Failure Prevention Section

# Two Speed Planetary

## Wear and Scoring

Clutch Plate - Improper Shift



Sliding Clutch - Improper Shift

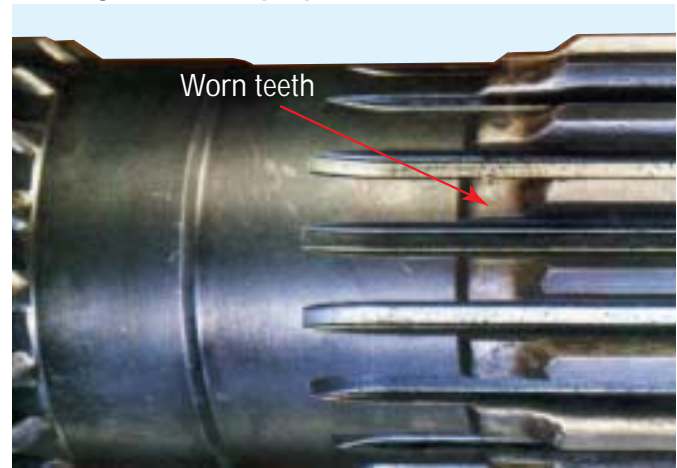

Bronze Idler Pins - Normal/Excessive Wear

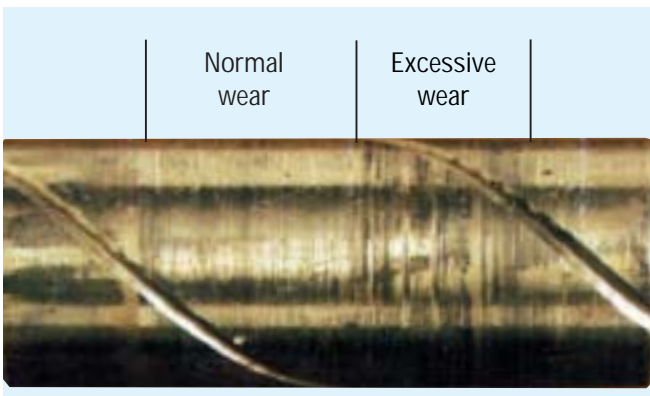

Bronze Idler Pin - Scoring



**General Description:** **Clutch plate and gear wear:** Improper shifting and excessive periodic shock loads result in wear on the teeth of the sliding clutch gear and mating plate.

**Scoring:** Incorrect lubrication or contaminated lube can cause etching, scoring, or pitting to the contact surface of bearings, gears, bushings, and thrust washers. Foreign materials in the lube act as an abrasive weakening the protective film and resulting in seizure of mating parts.

**Usual Causes:** **Clutch Plate and gear wear:**

- Improper shifting
- Excessive shock loads

**Scoring:**

- Incorrect lubrication
- Contaminated lube

**Failure Prevention:** • Maintenance, Rebuilding, and Adjustment - see Failure Prevention Section.

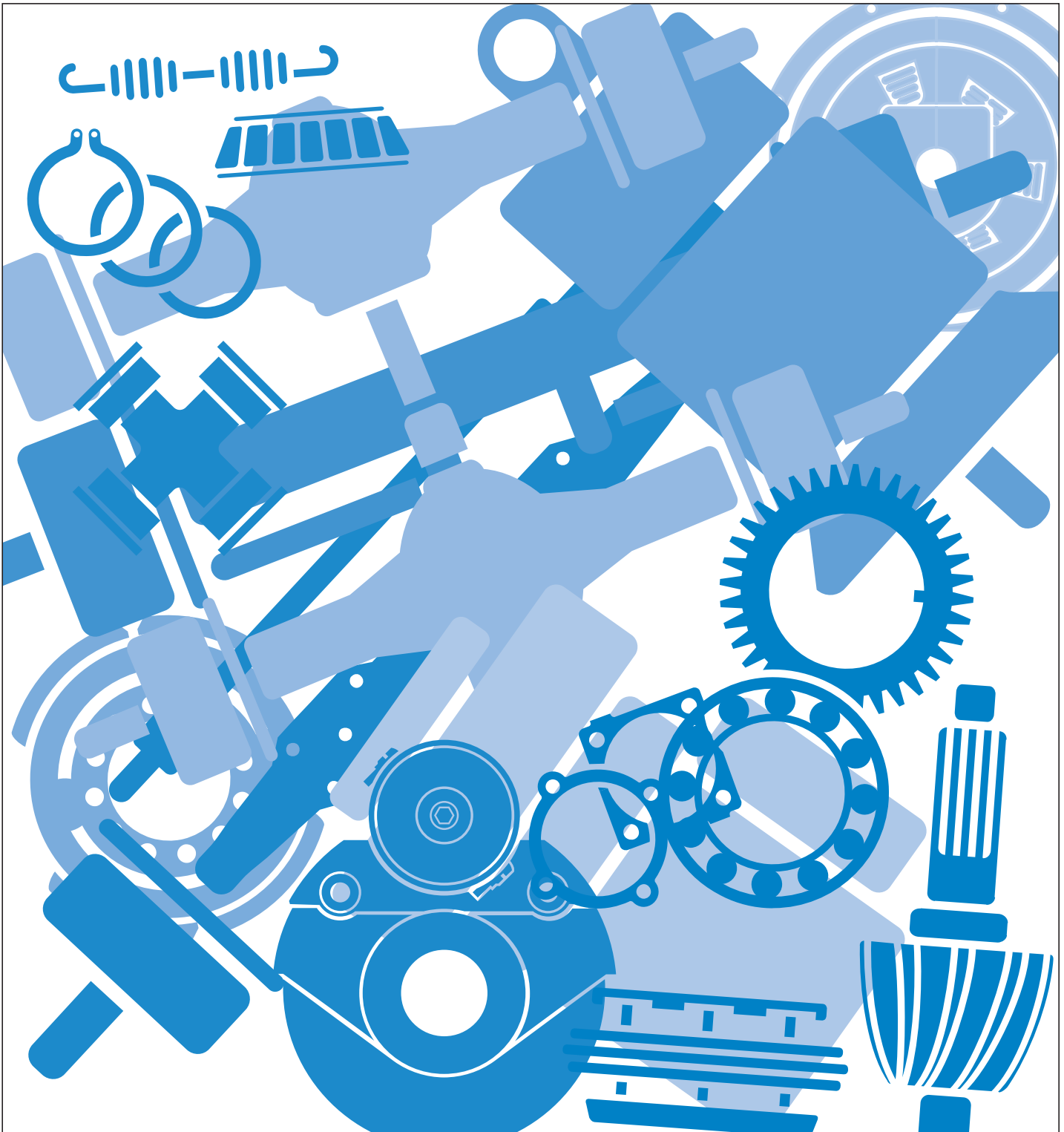

Copyright Eaton and Dana Corporation, 2002. EATON AND DANA CORPORATION hereby grants its customers, vendors, or distributors permission to freely copy, reproduce and/or distribute this document in printed format. THIS INFORMATION IS NOT INTENDED FOR SALE OR RE-SALE, AND THIS NOTICE MUST REMAIN ON ALL COPIES.



National Institute for  
**AUTOMOTIVE  
SERVICE  
EXCELLENCE**

## Roadranger®

**MORE TIME ON THE ROAD**

The Roadranger® System is an unbeatable combination of the best products from Eaton and Dana -- partnering to provide you the most advanced, most trouble-free drivetrain in the industry. And it's backed by the Roadrangers -- the most experienced, most expert, most accessible drivetrain consultants in the business.

For spec'ing or service assistance, call 1-800-826-HELP (4357) 24 hours a day, 7 days a week, (Mexico: 001-800-826-HELP (4357)) for more time on the road. Or visit our web site at [www.roadranger.com](http://www.roadranger.com).



One Great Drivetrain from Two Great Companies

AXSM-0020  
06/04 PDF  
Printed in USA