

Roadranger®

Eaton® Fuller® Automated Transmissions

CEEMAT™



EAT•N

One Great Drivetrain from Two Great Companies

Service Manual TRSM-0020 December 1993

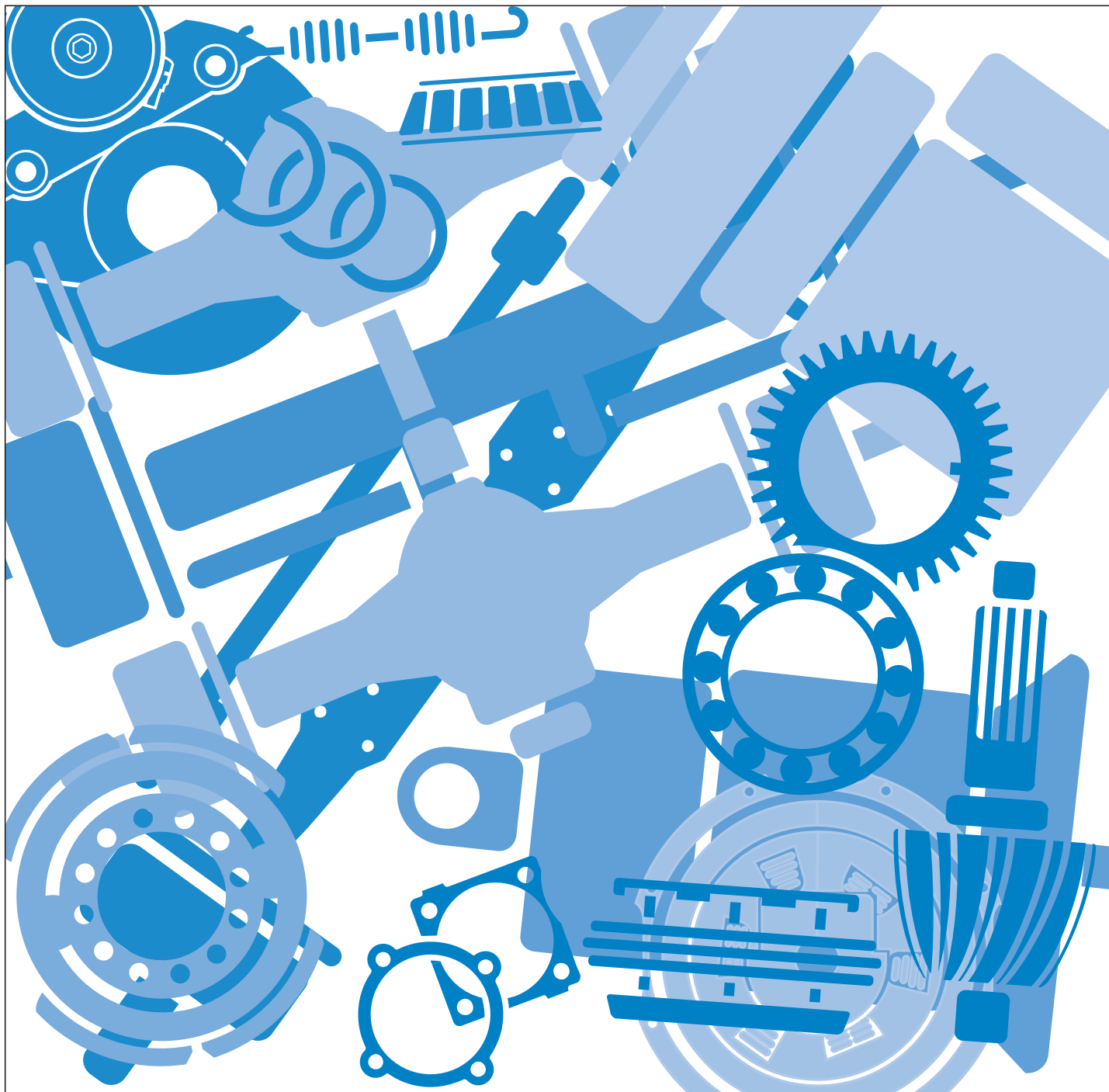

For the most current information, visit the Roadranger web site at www.roadranger.com



Warnings & Precautions

General Information

Model/Assembly Reference

External Parts

Shift Bar Housing

Front Section

Auxiliary Section

Options



Section 1: Warnings and Precautions

Warning

WARNING11

Precautions

Disassemble

Assemblies12
 Bearings12
 Cleanliness12
 Snap Rings12
 When using Tools to Move Parts13

Inspection

Autoshift Assembly13
 Bearings13
 Bearing Covers14
 Gears14
 Gray Iron Parts14
 O-Rings14
 Power Synchronizer Assembly14
 Rear Oil Seals14
 Reverse Idler Gear Assemblies14
 Shift Bar Housing Assembly15
 Sliding Clutches15
 Splines15
 Synchronizer Assembly15
 Washers15

Assemble

Axial Clearances16
 Bearings16
 Capscrews16
 Gaskets16
 Initial Lubrication16
 O-Rings16
 Universal Joint Companion Flange or Yoke16



Before starting a vehicle always be seated in the drivers seat, place the transmission in neutral, set the parking brakes.

Before working on a vehicle place the transmission in neutral, set the parking brakes and block the wheels.

Before towing the vehicle place the transmission in neutral and lift the drive wheels off the ground or disconnect the driveline to avoid damage to the transmission during towing.

Precautions

Disassemble

It is assumed in the detailed assembly instructions that the lubricant has been drained from the transmission, the necessary linkage, cooler lines, and air lines disconnected, and the transmission has been removed from vehicle chassis. Removal of the gear shift cable and electrical harness is included in the detailed instructions; however, they **MUST** be detached from the transmission before they can be removed from the chassis. For in shop disassembly, holding the transmission in the vertical position can be done securely by fastening a compatible companion flange to a large base, forming a holder for the output shaft splines. Use extreme caution when handling heavy equipment.

Follow closely each procedure in the detailed instructions, make use of the text, illustrations, and photographs provided.

The electronic control unit (ECU is a non-serviceable component. Follow the instructions in the "External Parts" section, careful to remove and protect the unit from damage.

Assemblies

When disassembling the various assemblies, such as the reverse idler, countershafts, and auxiliary section, lay all parts on a clean bench in the same sequence as removed. This procedure will simplify assembly and reduce the possibility of losing parts.

Bearings

Carefully wash and lubricate all usable bearings as removed and protectively wrap until ready for use. Remove bearings planned to be reused with pullers designed for this purpose.

Cleanliness

Provide a clean place to work. It is important that no dirt or foreign material enters the unit during repairs. Dirt is an abrasive and can damage bearings. It is always good practice to clean the outside of the unit before starting the planned disassembly.

Snap Rings

Remove snap rings with pliers designed for this purpose. Snap rings removed in this manner can be reused, if they are not sprung or loose.

When Using Tools to Move Parts

Always apply force to shafts, housings, etc., with restraint. Movement of some parts is restricted. Never apply force to driven parts after they stop solidly. The use of soft hammers, soft bars, and mauls for all disassembly work is recommended.

Inspection

Before assembling the transmission, check each part carefully for abnormal or excessive wear and damage to determine reuse or replacement. When replacement is necessary, use only genuine Eaton® Fuller® Transmission parts to assure continued performance and extended life from your unit.

Since the cost of a new part is generally a small fraction of the total cost of downtime and labor, avoid reusing a questionable part which could lead to additional repairs and expense soon after assembly. To aid in determining the reuse or replacement of any transmission part, consideration should also be given to the unit's history, mileage, application, etc.

Recommended inspection procedures are provided in the following checklist.

Autoshift Assembly

1. Autoshift finger should move side to side, fore and aft with frictional resistance only.

Bearings

1. Wash all bearings in clean solvent. Check balls, rollers, and raceways for pitting, discoloration, and spalled areas. Replace bearings that are pitted, discolored, spalled, or damaged during disassembly.
2. Lubricate bearings that are not pitted, discolored, or spalled and check for axial and radial clearances.
3. Replace bearings with excessive clearances.
4. Check bearing fit. Bearing inner races should be tight to shaft; outer races slightly tight to slightly loose in case bore. If bearing spins freely in bore, case should be replaced.

Bearing Covers

1. Check covers for wear from thrust of adjacent bearing. Replace covers damaged from thrust of bearing outer race.
2. Check cover bores for wear. Replace those worn or oversized.

continued on next page

Precautions

Inspection

Gears

1. Check gear teeth for frosting and pitting. Frosting of gear teeth faces presents no threat of transmission failure. Often in continued operation of the unit, frosted gears “heal” and do not progress to the pitting stage. In most cases, gears with light to moderate pitted teeth have considerable gear life remaining and can be reused, but gears in the advanced stage of pitting should be replaced.
2. Check for gears with clutching teeth abnormally worn, tapered, or reduced in length from clashing during shifting. Replace gears found in any of these conditions.
3. Check axial clearance of gears.

Gray Iron/Torque Converter Housing Parts

1. Check all gray iron parts for cracks and breaks. Replace parts found to be damaged.

Hydraulic Valve

1. Should be clean and free of contamination.

O-Rings

1. Check all O-rings for cracks or distortion. Replace if worn.

Oil Pump

1. Free from damage with no apparent leaks.

Power Synchronizer/Inertia Brake Assembly

1. Check the splined shaft and drive gear for free rotation.
2. No visual damage to band or disc and free of contamination.

Rear Oil Seals

1. Check oil seal in rear bearing cover. If sealing action of lip has been destroyed, replace the seal. Check the mating flange for damage.

Reverse Idler Gear Assemblies

1. Check for excessive wear from action of roller bearings.

continued on next page

Inspection

Shift Bar Housing Assembly

1. Check for wear on shift yokes and blocks at pads and lever slot. Replace excessively worn parts.
2. Check yokes for correct alignment. Replace sprung yokes.
3. Check lockscrews in yoke and blocks. Tighten and rewire those found loose.
4. If housing has been disassembled, check neutral notches of shift bars for wear from interlock balls.

Sliding Clutches

1. Check all shift yokes and yoke slots in sliding clutches for extreme wear or discoloration from heat.
2. Check engaging teeth of sliding clutches for partial engagement pattern.

Splines

1. Check splines on all shafts for abnormal wear. If sliding clutch gears, companion flange, or clutch hub has worn marks in the spline sides, replace the specific shaft affected.

Range Synchronizer Assembly

1. Check synchronizer for burrs, uneven and excessive wear at contact surface, and metal particles.
2. Check blocker pins for excessive wear or looseness.
3. Check synchronizer contact surfaces on the synchronizer cups for wear.

Washers

1. Check surfaces of all washers. Washer scored or reduced in thickness should be replaced.

Wiring Harnesses

1. Should have no abrasions, connector pins should be firmly seated.

Precautions

Assemble

Make sure that case interiors and housings are clean. It is important that dirt and other foreign materials are kept out of the transmission during assembly. Dirt is an abrasive and can damage polished surfaces of bearings and washers. Use certain precautions, as listed below, during assemble.

Axial Clearances

Maintain original axial clearances of .006" to .015" for mainshaft gears.

Bearings

Use a flange-end bearing driver for bearing installation. These special drivers apply equal force to both bearing races, preventing damage to balls/rollers and races while maintaining correct bearing alignment with bore and shaft. Avoid using a tubular or sleeve-type driver, whenever possible, as force is applied to only one of the bearing races.

Capscrews

To prevent oil leakage and loosening, use Eaton/Fuller sealant #71211 or equivalent on all capscrews. For torque ratings, use the torque recommendations through out the service manual.

Gaskets

Use new gaskets throughout the transmission as it is being rebuilt. Make sure all gaskets are installed. An omission of any gasket can result in oil leakage or misalignment of bearing covers.

Initial Lubrication

Coat all limit washers and shaft splines with Lubriplate during assembly to prevent scoring and galling of such parts.

O-Rings

Lubricate all O-rings with silicon lubricant.

Universal Joint Companion Flange or Yoke

Pull the companion flange or yoke tightly into place with the output shaft nut, using 450-500 Lb_f·ft of torque. Make sure the speedometer drive gear or a replacement spacer of the same width has been installed. Failure to pull the companion flange or yoke tightly into place can result in damage to the mainshaft rear bearing.

IMPORTANT: See the appropriate Illustrated Parts Lists (specified by model series) to ensure that proper parts are used during assembly of the transmission.



Section 2: General Information

How to Use This Manual	3
Model Designation	5
Lubrication	
Maintain Proper Oil Level	6
Draining Oil	7
Refilling	7
Flush Procedure	8
Maintenance Interval Chart	9
Recommended Lubricant Chart	9
Transmission Operating Angles	10
Operating Temperatures with Oil Coolers	11
Power Flow	
Torque Converter Mode: LO Range	12
Torque Converter Mode: Lockup Mode	14
Auxiliary Section: HI Range	15
Timing	
Front Section	16
Auxiliary Section	17
Tool Reference	18
Preventive Maintenance	19
Checks Before Transmission Removal	20
Checks with Drive Line Dropped	21
Checks With Universal Joint Companion Flange or Yoke Removed	21

This manual is designed to provide detailed information necessary to service and repair the Eaton® Fuller® transmissions listed on the front.

As outlined on the first page, the manual has been divided into its main components: external parts, shift bar housing, front section, auxiliary section, and options (if applicable). Each component has its own tabbed section. Each tabbed section has its own table of contents and procedural flow charts. The table of contents lists the procedures. The flow charts represent the order in which the transmission should be disassembled or assembled. The procedures have two parts, disassembly or removal and reassembly or installation.

The following is the general layout with descriptions.

1. Heading

Gives a general description of the topic covered.

2. Subhead

Gives a more specific description of the topic covered.

3. Special Instructions

Procedures that need to be done before performing the topic covered. Hints that will make the procedure easier to perform.

4. Special Tools

For most procedures typical service mechanic tools are all that is required, but sometimes a "special" tool is needed to prevent damaging the transmission.

5. The "How to"

The actual procedure to be performed.

6. Illustrations and pictures

To further help explain and illustrate the procedures.

7. Final Check

Must do's for proper performance.

8. Page Number/Section

Tells what page your on and in what section.

Air 1 em

How to Install the Air Supply Hoses 2 and HI Range

Special Instructions 3
Make sure air hoses are not damaged.
Install the air hoses at their proper locations.
All externally threaded 1/4" air fittings that are not coated with pre-applied sealant must be coated with Eaton sealing compound 71209 or equivalent for at least 3 complete and 4 consecutive threads.
For the 1/4" I.D. air hoses, install the fixed nut end first.
To install the hoses, the air filter/regulator must be in position.

Special Tools 5
Typical service mechanic tools

To Install

1. Connect one air supply hose end to the range cylinder HI range supply port.
2. Connect the other end to the slave valve HI range supply port.
3. Connect one air supply hose end to the range cylinder LO range supply port.
4. Connect the other end to the slave valve LO range supply port.

Final Check 7
Make sure air lines are not kinked.

6

8

Transmission appearance may differ, procedure is the same.

How to Use This Manual

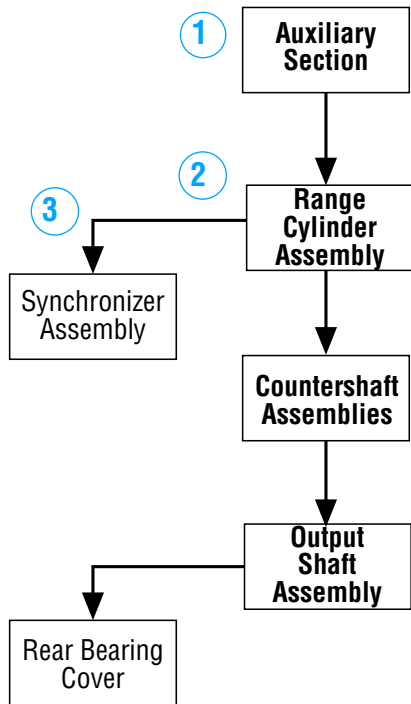

DS/AS-3

As mentioned on the previous page, the flow charts represent the order in which the transmission should be disassembled or assembled.

The following is an example of how to disassemble the auxiliary section, specifically the synchronizer assembly.

Follow the flow chart "How to Disassemble the Auxiliary Section".

1. Remove the auxiliary section from the front box.
2. Remove the range cylinder assembly.
3. Disassemble the synchronizer.

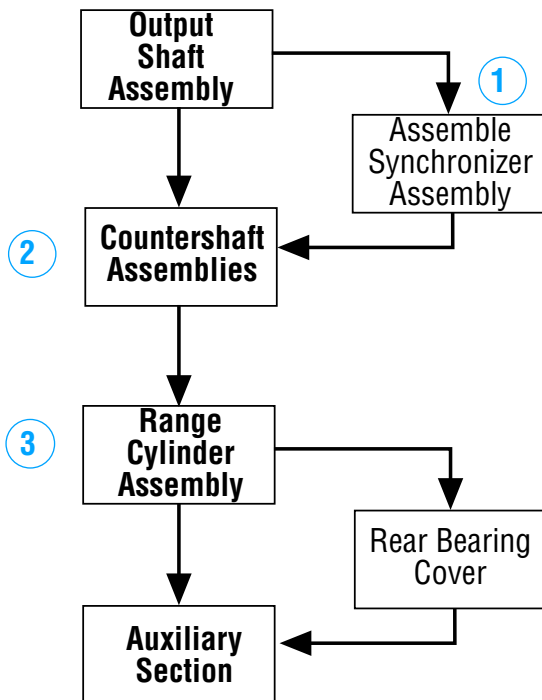

AS/AS-4

Once the synchronizer parts have been replaced, assemble the auxiliary section according to the "How to Assemble the Auxiliary Section".

1. Assemble the synchronizer assembly.
2. Install the countershaft assemblies, if they were removed.
3. Install the range cylinder assembly.

Lubrication

Proper lubrication procedures are the key to a good all-around maintenance program. If the oil is not doing its job, or if the oil level is ignored, all the maintenance procedures in the world are not going to keep the transmission running or assure long transmission life.

Eaton® Fuller® Transmissions are designed so that the internal parts operate in an oil bath circulated by the motion of the gears and shafts. Thus, all parts are amply lubricated if these procedures are closely followed:

1. Maintain oil level. Inspect regularly.
2. Change oil and filters regularly.
 - Use the correct grade and type of oil.
 - Buy oil from a reputable dealer.

Additives and friction modifiers are not recommended for use in Eaton Fuller Transmissions.

1. Maintain Proper Oil Level

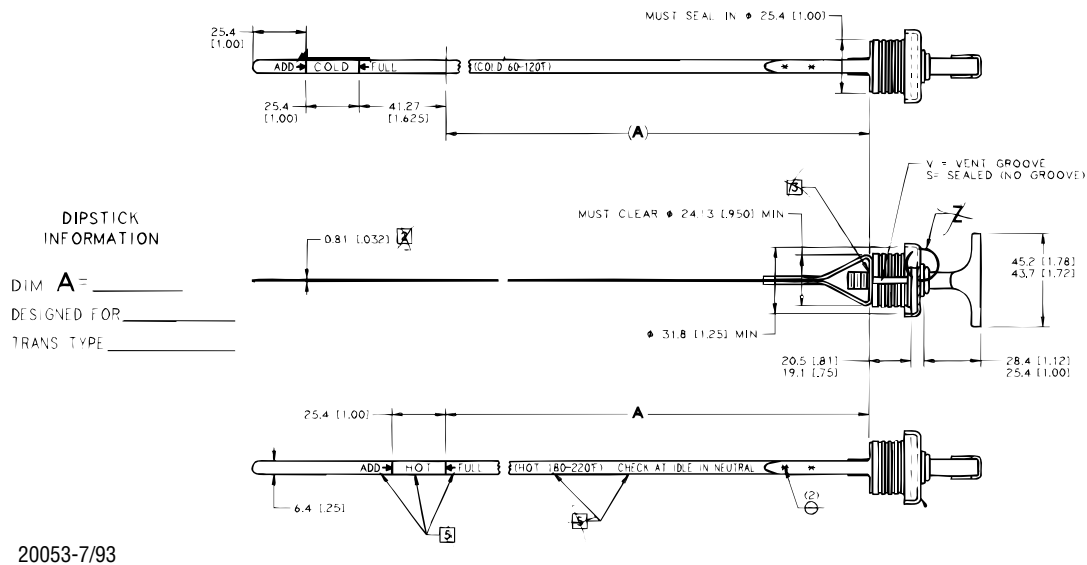

Different Views of the Oil Dipstick

Make sure oil is within dipstick marks for the corresponding oil temperature. Oil should be checked at idle speed in the neutral position using the corresponding temperature band. Cold checks can be performed when the oil temperature is 60–120°F. The oil level should be within the dipstick “cold” band. Additional checks can be made with the transmission at operating temperature by using the “hot” band on the opposite side of the dipstick. The “hot” band temperature range is 180–220°F.

2. Draining Oil

Drain transmission while oil is at ambient temperature ($65^{\circ}\text{F} \pm 20$). To drain oil, remove the main case drain plug and the converter housing oil pan drain plug. Clean the drain plugs and flush the cooler circuit before re-installing.

A complete hydraulic circuit flush should be completed when:

- changing oil types and brands.
- changing oil viscosity grades from or to Arctic oil.
- a catastrophic failure has occurred.

3. Refilling

The operational level should always be within the limit marks on the dipstick. The exact amount of oil depends on the transmission inclination and model. Insufficient oil damages the pump and other components, and can affect the function and reduce the life of the transmission.

DO NOT OVERFILL! This causes overheating and loss of fuel economy.

When adding oil, types and brands of oil should not be mixed because of possible incompatibility.

When changing oil viscosity to Arctic oil or alternate viscosity ranges, follow the recommended transmission oil flush procedure.

Use clean oil and clean containers when filling transmission. Containers that have been used for anti-freeze or water should not be used for transmission oil.

1. Remove the dipstick and slowly add seven (7) gallons of the prescribed oil through the filltube.
2. Place the transmission in the **neutral** position and apply the parking brakes. Start the engine and let it idle for 5 minutes, (this allows oil to fill the converter, main case, and cooling system), add oil as needed to obtain a level at the proper temperature range, (cold band under 120°F , hot band between 180 and 220°F). Total oil quantity needed at this time should be approximately 10 gallons; this varies depending on the cooling system.
3. Increase the engine idle slowly to 1500 RPM for two (2) minutes. Now recheck the oil level at normal idle speed in neutral, again adding oil to obtain a level at the proper temperature range (cold band under 100°F , hot band between 180 and 220°F).
4. Replace the dipstick and tighten securely.

Lubrication

4. Flush Procedure

1. Disconnect the transmission cooler supply line between the transmission outlet and the oil cooler, (not between the cooler and the transmission oil pan).
2. With clean dry air from a hose and nozzle (20 psi), use a rubber stopper or clean rag to seal the air hose to the converter outlet hose.
3. Apply air to the converter outlet for approximately 2 minutes to backflush oil into the transmission oil pan.
4. Connect the hose between the transmission and cooler. Tighten to vehicle manufacturers specifications.
5. Install the transmission converter housing oil pan drain plug, tighten to 14-20 Lb_f·ft of torque.
6. Install the transmission main case drain plug (rear @ bottom), tighten to 45-50 Lb_f·ft of torque.
7. Remove the transmission dipstick and slowly pour 7 gallons of the appropriate oil into the transmission.
8. Apply the vehicle parking brakes and place the transmission lever in **neutral**. Start the engine and let it idle for 5 minutes. Check the dipstick periodically while the engine is idling, adding oil as needed to obtain a level that is in the **Cold Band** on the dipstick. Total quantity added at this time should be approximately 10 gallons.
9. With the transmission still in neutral, increase the engine idle speed to 1500 rpm and retain at this speed for 5 minutes. Now recheck the oil level at normal engine idle speed in neutral, again adding oil as required on the dipstick. Total oil quantity added at this time should be ≈11 gallons.

Transmission Temperature (°F)	
180 to 220	Oil level between the add-hot and full-hot marks.
Below 120	Oil level at the cold fill mark.

5. Maintenance Interval Chart

Lubrication Change and Inspection	
HIGHWAY USE	
First 1,000 to 1,500 miles	Change transmission oil, filter, and strainer on new units.
Every 2,500 miles	Inspect lubrication level. Check for leaks.
Every 50,000 miles or 1 year	Change transmission lubricant and filter. Check the strainer for dirt.
OFF-HIGHWAY USE	
First 30 hours	Change transmission oil, filter, and strainer on new units.
Every 40 hours	Inspect lubrication level. Check for leaks.
Every 500 hours	Change transmission lubricant and filter where severe dirt conditions exist.
Every 1,000 hours	Change transmission lubricant and filter. (Normal off-highway use.)

6. Recommended Lubricant Chart

Recommended Lubricant		
Type	Grade (SAE)	Fahrenheit (Celsius) Ambient Temperature
Dexron® II		Above 0°F (-32°C)
C4Type MIL-L-2104E	10W	Above 0°F (-32°C)
Arctic Oil	0W-20	Below 0°F (-32°C)

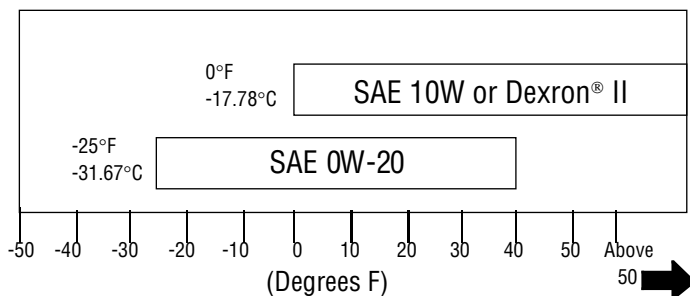

Minimum Temperature For Operating Transmission

Transmission appearance may differ, procedure is the same.

Lubrication

7. Buy from a reputable dealer

For a complete list of approved and reputable dealers, write to:

Eaton Corporation
Truck Component Marketing Headquarters
P.O. Box 4013
Kalamazoo, MI 49003

Transmission Operating Angles

If the transmission operating angle is more than 12 degrees, improper lubrication can occur. A special kit may be required for sustained operation on grades greater than 12 degrees.

Operating Temperatures with Oil Coolers

An external oil cooler is required on the automatic transmission in order to maintain proper operating temperatures*. Transmission oil temperature is sensed from the torque converter outlet port before the oil enters the cooler.

Normal operating temperature, when sensed from the torque converter outlet port, should be below 250°F; however, intermittent operating temperatures to 300°F do not harm the transmission.

On vehicles equipped with two transmission oil temperature gauges, one gauge (required) senses torque converter oil as mentioned above, while the other gauge (optional) reads oil temperature from the transmission sump. The sump temperature represents oil that has circulated through the cooler. This temperature is normally below 225°F; however, intermittent sump temperatures to 250°F do not harm the transmission.

When the average temperature of the transmission oil exceeds the temperature limits as stated above, more frequent oil changes may be needed.

The following conditions in any combination can cause the recommended transmission oil temperatures to be exceeded: (1) operating the transmission in a "stall" condition; i.e., extended operation while in gear with the vehicle stopped or slowly moving, (2) high density of starts and stops at slow operating speed, (3) minimal cooler capacity and/or restricted air flow to the transmission oil cooler, (4) exhaust system too close to the transmission, (5) improper oil level/incorrect oil.

*Engineering approval is required for cooler sizing on all new CEEMAT™ applications.

Power Flow

The transmission must efficiently transfer the engine's power to the vehicle's driveline. Knowledge of what takes place in the transmission is helpful when troubleshooting and making repairs.

Torque Converter Mode: LO Range

1. Power (torque) from the vehicle's engine is transferred to the torque converter's splined cover.
2. The impeller spins directing oil through the torque converter.
3. The oil flow hits the turbine causing the turbine to rotate. The power is related to the speed difference between the impeller and the turbine.
4. The turbine is connected to the interrupt clutch housing. The interrupt clutch inner hub is splined directly to the transmission input shaft.
5. When the interrupt clutch is activated, the housing and the inner hub are connected to complete the mechanical link and transfers power to the input shaft.

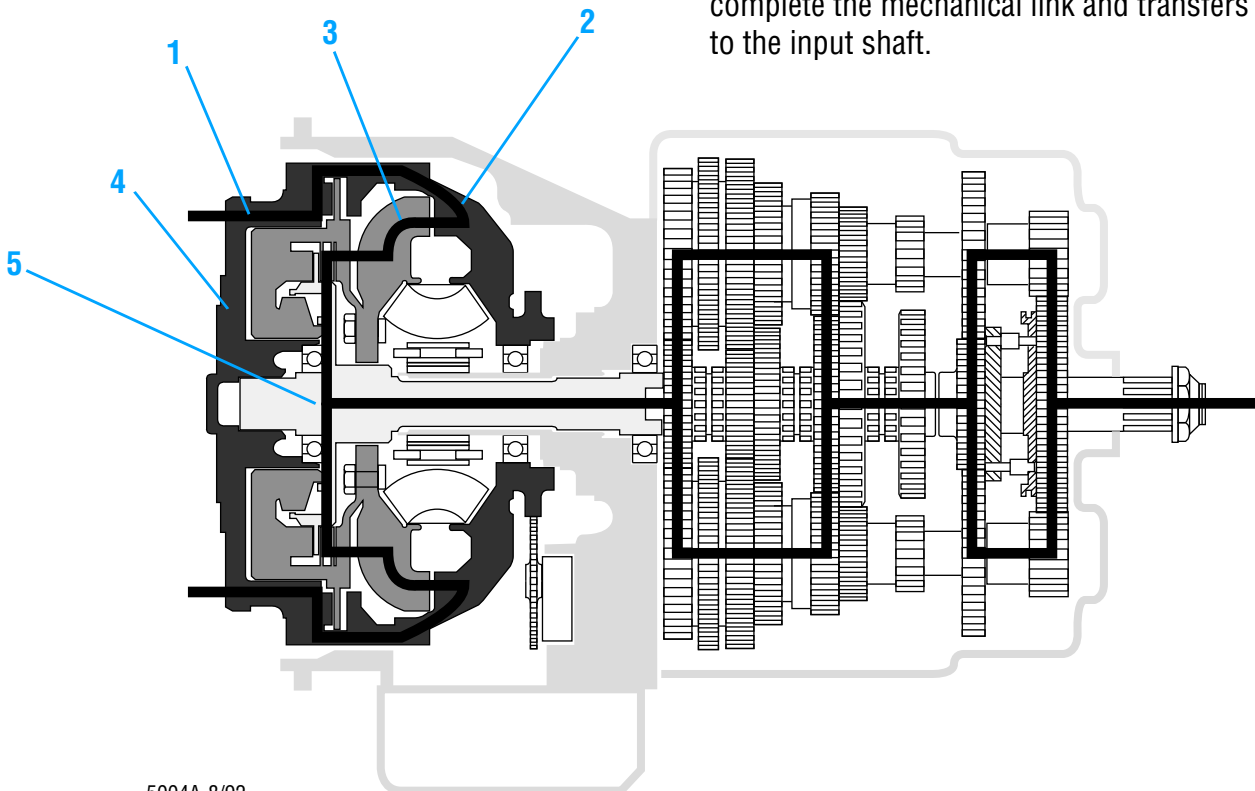

5004A-8/92

6. Input shaft splines engage the internal splines in the main drive gear hub.
7. Torque is split between the two countershaft drive gears.
8. Torque is delivered along both countershafts to mating countershaft gear of the "engaged" mainshaft gear (1st gear in this example).
9. The internal clutching teeth in the engaged mainshaft gear hub transfers torque to the mainshaft through the sliding clutch.
10. The mainshaft transfers torque directly to the auxiliary drive gear.
11. The auxiliary drive gear splits torque between the two auxiliary countershaft drive gears.
12. Torque is delivered along both countershafts to the "engaged" LO range gear on the range mainshaft or output shaft.
13. Torque is transferred to the output shaft through a sliding clutch.
14. Torque is delivered to the driveline as LO range 1st.

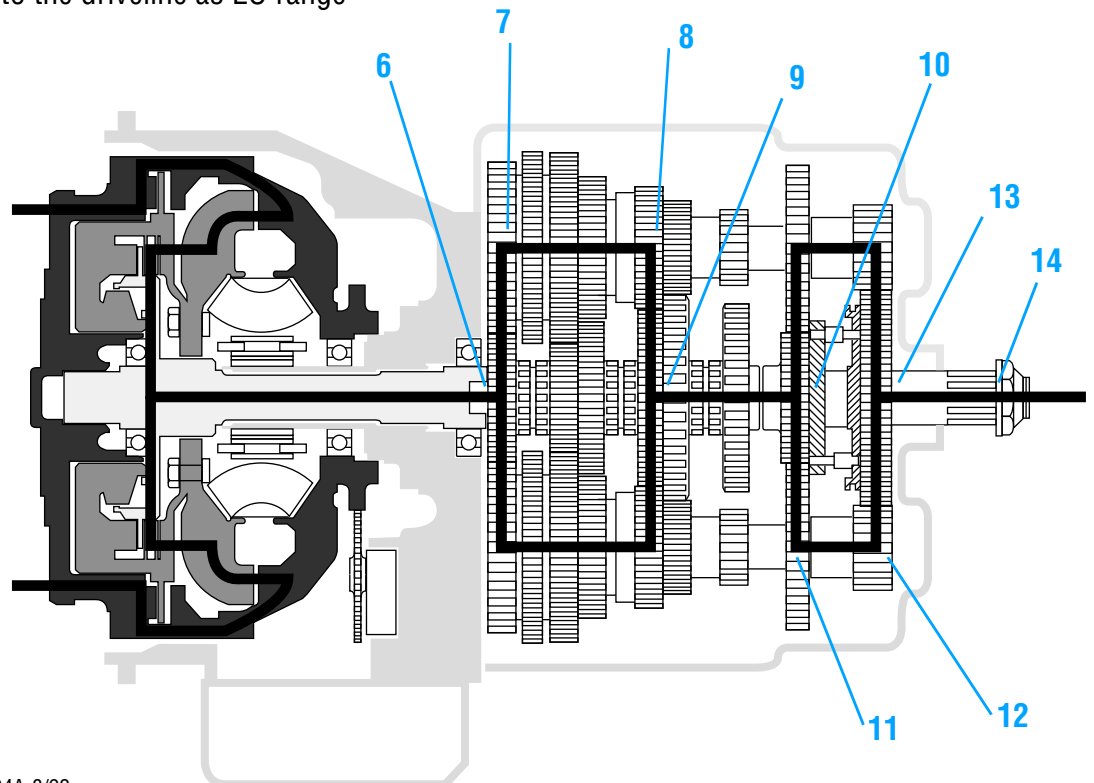

5004A-8/92

Power Flow

Torque Converter Mode: Lockup Mode

1. Power (torque) from the vehicle's engine is transferred to the torque converter's splined cover.
2. The splined cover is connected to the lockup clutch.
3. The lockup clutch is splined directly to the interrupt clutch outer hub. When the lockup clutch is activated, the interrupt clutch is driven directly from the engine.
4. The interrupt clutch inner hub is splined directly to the transmission input shaft.
5. When the interrupt clutch is activated, the torque is transmitted directly from the engine to the input shaft from the lockup clutch. The losses from the slippage in the torque converter are eliminated in this manner.

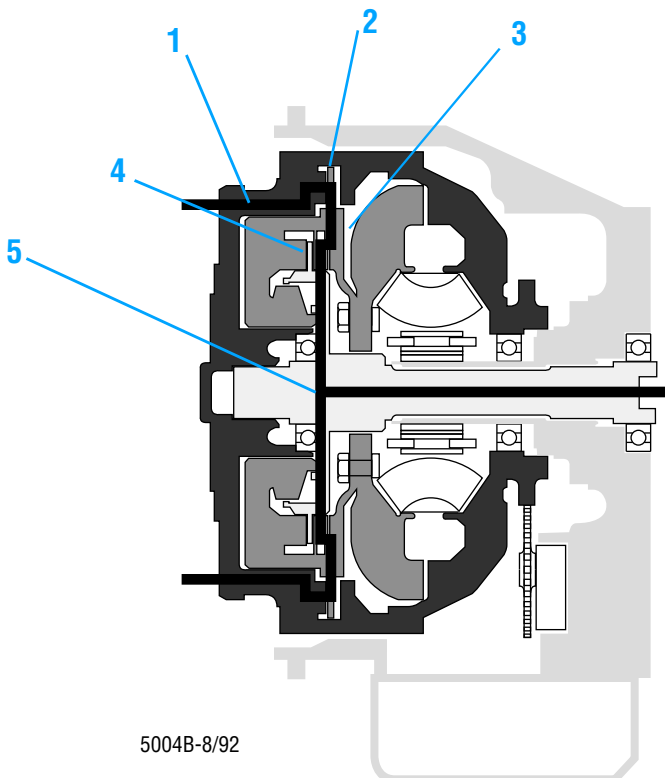

5004B-8/92

Auxiliary Section: HI Range

6. Input shaft splines engage the internal splines in the main drive gear hub.
7. Torque is split between the two countershaft drive gears.
8. Torque is delivered along both countershafts to mating countershaft gear of the "engaged" mainshaft gear.
9. The internal clutching teeth in the engaged mainshaft gear hub transfers torque to the mainshaft through the sliding clutch.
10. The mainshaft transfers torque directly to the auxiliary drive gear.
11. The auxiliary drive gear transfers torque directly to the range mainshaft or output shaft through the "engaged" sliding clutch.
12. Torque is delivered through the output shaft to the driveline as HI range 6th.

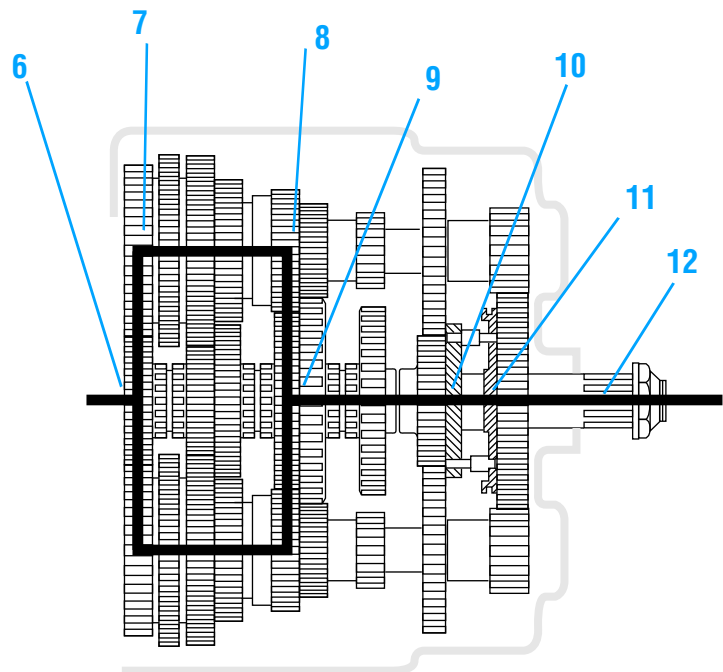

5004C-8/92

Timing

Timing Procedures

It is essential that both countershaft assemblies of the front and auxiliary sections are "timed." This assures proper tooth contact is made between mainshaft gears seeking to center on the mainshaft during torque transfer and mating countershaft gears that distribute the load evenly. If not properly timed, serious damage to the transmission is likely to result from unequal tooth contact causing the mainshaft gears to climb out of equilibrium.

Timing is a simple procedure of marking the appropriate teeth of a gear set prior to installation and placing them in proper mesh while in the transmission. In the front section, it is necessary to time only the drive gear set. And depending on the model, only the LO range, deep reduction, or splitter gear set is timed in the auxiliary section.

Front Section

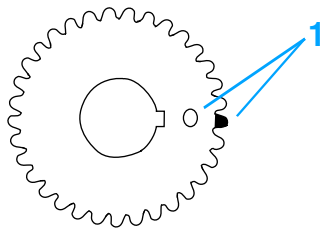

A. Marking countershaft drive gear teeth.

1. Prior to placing each countershaft assembly into the case, clearly mark the tooth located directly over the drive gear keyway as shown. This tooth is stamped with an "O" to aid identification.

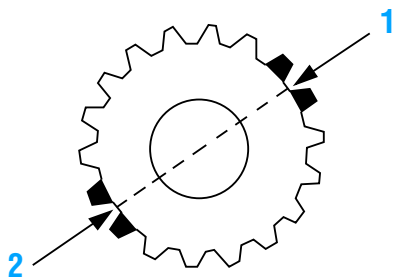

B. Marking main drive gear teeth.

1. Mark any two adjacent teeth on the main drive gear.
2. Mark the two adjacent teeth located directly opposite the first set marked on the main drive gear. As shown to the left, there should be an equal number of unmarked gear teeth on each side between the marked sets.

Timing Procedures (cont)

C. Meshing marked countershaft drive gear teeth with marked main drive gear teeth.

(After placing the mainshaft assembly into the case, the countershaft bearings are installed to complete installation of the countershaft assemblies.)

1. When installing the bearings on the left countershaft, mesh the countershaft drive gear marked tooth with either set of main drive gear two marked teeth.
2. Repeat the procedure when installing the bearings on the right countershaft, make use of the remaining set of main drive gear two marked teeth to time assembly.

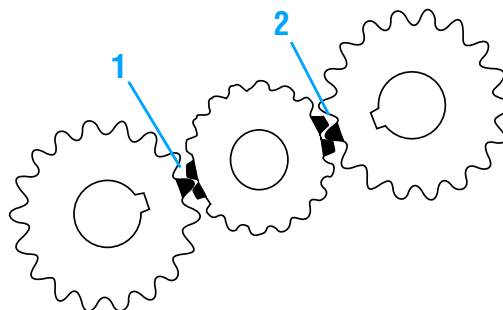

Auxiliary Section

Standard Auxiliary Section

1. Mark any two teeth on the LO range gear. Then mark two teeth located directly opposite the first marked.
2. Prior to placing each auxiliary countershaft assembly into housing, mark the tooth on each auxiliary countershaft assembly LO range gear stamped with the "O".
3. Follow the assembly procedures in the "Auxiliary Section".

Tool Reference

Some repair procedures pictured in this manual show the use of specialized tools. Their actual use is recommended as they make transmission repair easier, faster, and prevent costly damage to critical parts.

But for the most part, ordinary mechanic's tools such as socket wrenches, screwdrivers, etc., and other standard shop items such as a press, mauls and soft bars are all that is needed to successfully disassemble and reassemble any Eaton Fuller Transmission.

The specialized tools can be obtained from a tool supplier or made from tool prints as required by the individual user. Detailed Eaton Fuller Transmission Tool Prints are available upon request by writing to:

Eaton Corporation
Transmission Division
Technical Service Dept.
P.O. Box 4013
Kalamazoo, Michigan 49003

Preventive Maintenance

Everyday there are countless vehicles operating over the highways with transmissions in such a neglected mechanical condition, they can be referred to as failures looking for a place to break down. They lack a proper and organized preventive maintenance program.

Preventive maintenance is a general term which applies to all procedures necessary to have maximum life and satisfactory service at the lowest possible cost, short of removing and repairing the unit.

A number of conditions contrary to good preventive maintenance can generally be pointed to when inspecting a failed transmission. Taking a few minutes every so many hours or miles to do a few simple checks could help avoid eventual breakdown or reduce the repair cost. If the transmission is not cared for, it will breakdown.

Preventive Maintenance

Checks Before Transmission Removal

1 Air System and Connections (not shown)

Annually replace the filter/regulator element. If excessive contamination is present, service vehicle air/dryer system.

2 Lubricant and Filter

Change at specified service intervals.

Use only the types and grades as recommended. See LUBRICANTS.

Check lubrication lines and cooling circuit for leaks.

3 Dipstick (not shown)

Remove dipstick and check level of lubricant at specified intervals. Check oil in neutral at engine idle.

4 Drain Plugs

Tighten the drain plugs securely. Tighten the main case drain plug to 45-50 Lb_f·ft of torque. Tighten oil pan plugs to 14-20 Lb_f·ft of torque.

5 Capscrews and Gaskets

Check all capscrews, especially those on PTO covers and rear bearing covers for looseness which would cause oil leakage. Use the torque recommendations identified in this service manual.

Check PTO opening, oil sump/strainer, hose fittings, and rear bearing covers for oil leakage due to faulty gaskets.

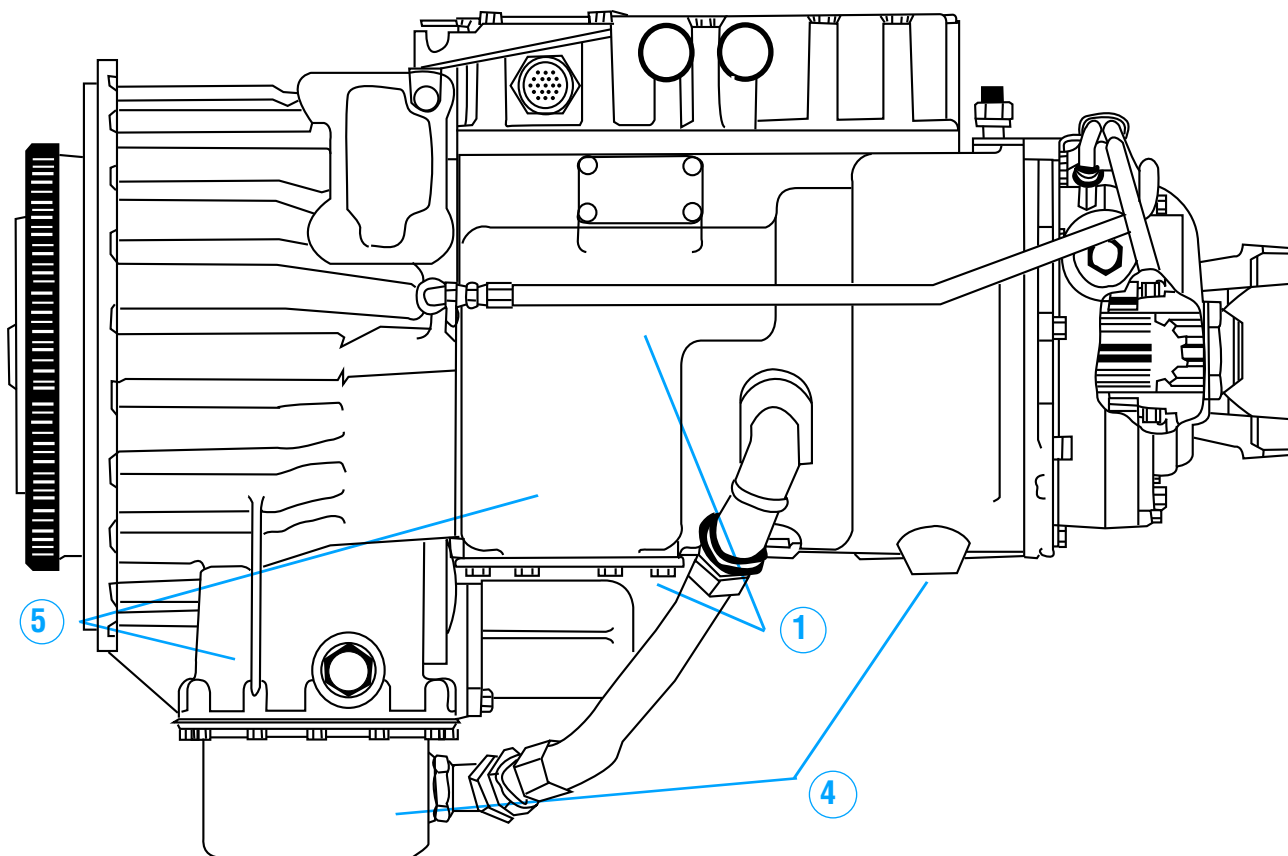

Checks with Drive Line Dropped

⑥ Universal Joint Companion Flange or Yoke Nut

Check for tightness. Tighten to recommended torque.

⑦ Output Shaft

Pry upward against output shaft to check radial clearance in mainshaft rear bearing.

Checks With Universal Joint Companion Flange or Yoke Removed

NOTE: If necessary, use solvent and shop rag to clean sealing surface of companion flange or yoke. **Do not use crocus cloth, emery paper, or other abrasive materials that will mar surface finish.**

⑧ Splines on Output Shaft

Check for wear from movement and chucking action of the universal joint companion flange or yoke.

⑨ Mainshaft Rear Bearing Cover

Check oil seal for wear.

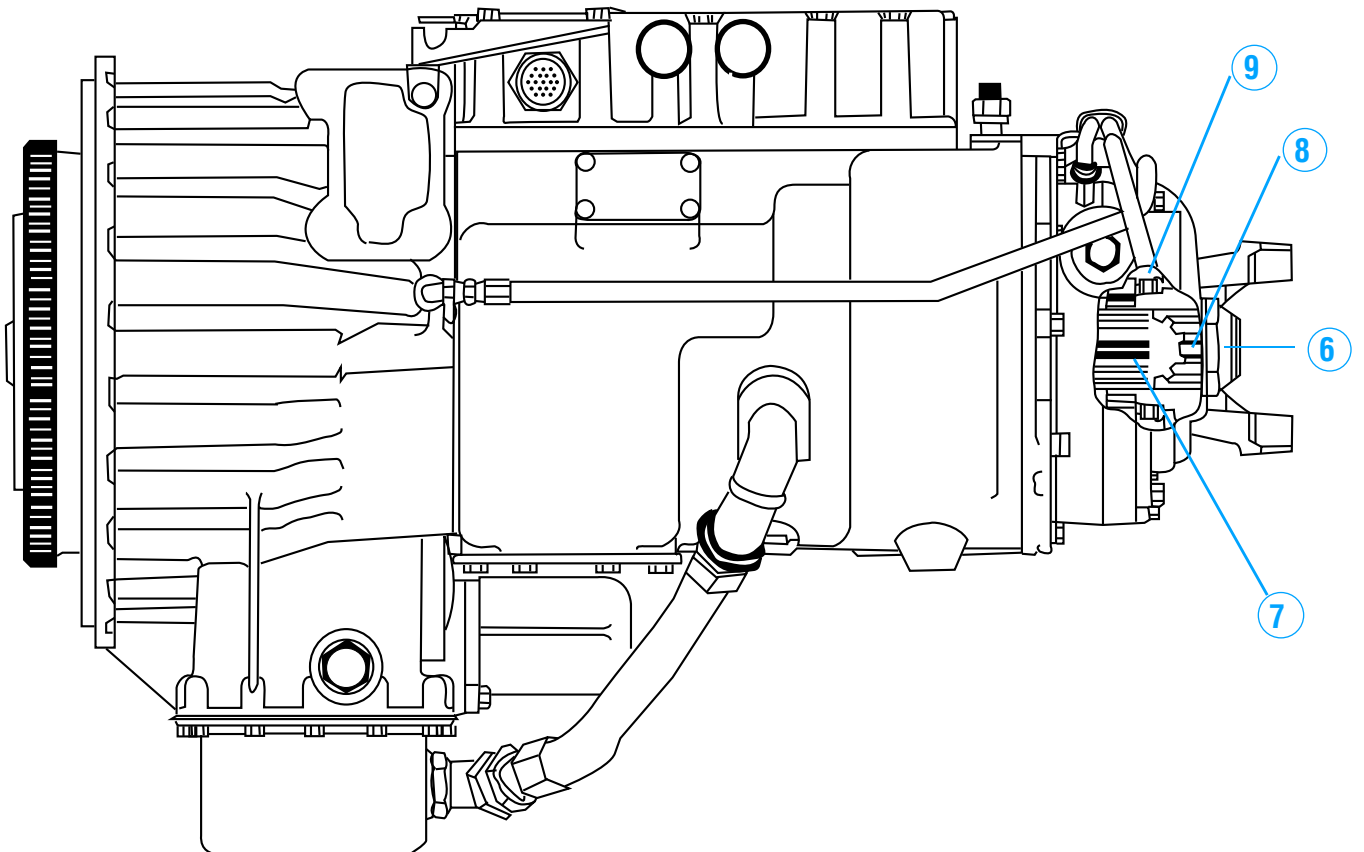

Section 3: Model/Assembly Reference

CEEMAT-AT	2
CEEMAT-ATR	4
CEEMAT-ATS	6
CEEMAT-ATE	8



Remove/
Disassemble Install/
Assemble
(page numbers)

External Parts

Air System

Air Supply Hoses for the Power Synchronizer	4	5
Air Supply Hose for LO and HI Range	8	9
Air Filter/Regulator	10	11
Slave Valve	12	13

Lube System

Lube Supply Hose for the Power Synchronizer	14	15
Oil Pan/Strainer	18	19
Oil Filter	20	21

Synchronizer System

Power Synchronizer	22	23
--------------------	----	----

Shift Bar Housing

Shift Bar Housing Cover	24	25
Autoshift Harness	26	27
Autoshift Assembly	28	29
Shift Bar Housing	30	31

Torque Converter

Torque Converter	32	33
Hydraulic Valve	34	35
Dip Stick	36	37
Torque Converter Housing	38	39
Oil Pump	40	41
Filter Bypass Valve	42	43
HI Pressure Relief Valve	42	43

Output Yoke/Companion Flange

	44	45
--	----	----

Auxiliary Section

Auxiliary Section	46	47
Rear Bearing Cover Assembly	48	49



Remove/
Disassemble Install/
Assemble
(page numbers)

Shift Bar Housing

Shift Bar Housing	4	6
-------------------	---	---

Front Section

Auxiliary Drive Gear Assembly	4, 6	5, 7
Reverse Idler Gear Assembly	8	9
Countershaft Assembly		
Countershaft Bearings	10	11
Countershaft Assembly	12, 14	13, 15
Mainshaft Assembly (may have 3 grooves)	16, 18	17, 19
Input Shaft Assembly	22	23

Auxiliary Section

Range Cylinder Assembly		
Range Cylinder Assembly	4	5
Synchronizer Assembly	6	7
Countershaft Assembly	8	9
Output Shaft Assembly/Rear Bearing	12	13



Remove/
Disassemble Install/
Assemble
(page numbers)

External Parts

Air System

Air Supply Hoses for the Inertia Brake	6	7
Air Supply Hose for LO and HI Range	8	9
Air Filter/Regulator	10	11
Slave Valve	12	13

Lube System

Lube Supply Hose for the Inertia Brake	16	17
Oil Pan/Strainer	18	19
Oil Filter	20	21

Synchronizer System

Inertia Brake	22	23
---------------	----	----

Shift Bar Housing

Shift Bar Housing Cover	24	25
Autoshift Harness	26	27
Autoshift Assembly	28	29
Shift Bar Housing	30	31

Torque Converter

Torque Converter	32	33
Hydraulic Valve	34	35
Dip Stick	36	37
Torque Converter Housing	38	39
Oil Pump	40	41
Filter Bypass Valve	42	43
HI Pressure Relief Valve	42	43

Output Yoke/Companion Flange

	44	45
--	----	----

Auxiliary Section

Auxiliary Section	46	47
Rear Bearing Cover Assembly	48	49



Remove/
Disassemble Install/
Assemble
(page numbers)

Shift Bar Housing

Shift Bar Housing	4	6
-------------------	---	---

Front Section

Auxiliary Drive Gear Assembly	4, 6	5, 7
Reverse Idler Gear Assembly	8	9
Countershaft Assembly		
Countershaft Bearings	10	11
Countershaft Assembly	12, 14	13, 15
Mainshaft Assembly (may have 3 grooves)	16, 18	17, 19
Input Shaft Assembly	22	23

Auxiliary Section

Range Cylinder Assembly		
Range Cylinder Assembly	4	5
Synchronizer Assembly	6	7
Countershaft Assembly	8	9
Output Shaft Assembly/Rear Bearing	12	13



Section 4: External Parts

Air System

How to Remove the Air Supply Hoses for the Power Synchronizer	4
How to Install the Air Supply Hoses for the Power Synchronizer	5
How to Remove the Air Supply Hose for the Inertia Brake	6
How to Install the Air Supply Hoses for the Inertia Brake	7
How to Remove the Air Supply Hoses for LO and HI Range	8
How to Install the Air Supply Hoses for LO and HI Range	9
How to Remove the Air Filter/Regulator	10
How to Install the Air Filter/Regulator	11
How to Remove a Slave Valve	12
How to Install a Slave Valve	13

Lube System

How to Remove the Lube Supply Hose for the Power Synchronizer	14
How to Install the Lube Supply Hose for the Power Synchronizer	15
How to Remove the Lube Supply Hose for the Inertia Brake	16
How to Install the Lube Supply Hoses for the Inertia Brake	17
How to Remove the Oil Tube and Oil Pan/Strainer	18
How to Install the Oil Tube and Oil Pan/Strainer	19
How to Remove the Oil Filter	20
How to Install the Oil Filter	21

Synchronizer Systems

How to Remove the Power Synchronizer	22
How to Install the Power Synchronizer	23
How to Remove the Inertia Brake	22
How to Install the Inertia Brake	23



Shift Bar Housing

How to Remove the Shift Bar Housing Cover	24
How to Install the Shift Bar Housing Cover	25
How to Remove the Autoshift Harness	26
How to Install the Autoshift Harness	27
How to Remove the Autoshift Assembly	28
How to Install the Autoshift Assembly	29
How to Remove the Shift Bar Housing	30
How to Install the Shift Bar Housing	31

Torque Converter

How to Remove the Torque Converter	32
How to Install the Torque Converter	33
How to Remove the Hydraulic Valve	34
How to Install the Hydraulic Valve	35
How to Remove the Dip Stick	36
How to Install the Dip Stick	37
How to Remove the Torque Converter Housing	38
How to Install the Torque Converter Housing	39
How to Remove the Oil Pump	40
How to Install the Oil Pump	41
How to Remove the Filter Bypass Valve	42
How to Install the Filter Bypass Valve	43
How to Remove the HI Pressure Relief Valve	42
How to Install the HI Pressure Relief Valve	43

Output Yoke/Companion Flange

How to Remove the Output Yoke/Companion Flange	44
How to Install the Output Yoke/Companion Flange	45

Auxiliary Section

How to Remove the Auxiliary Section	46
How to Install the Auxiliary Section	47
How to Remove the Rear Bearing Cover Assembly	48
How to Install the Rear Bearing Cover Assembly	49

Air System

How to Remove the Air Supply Hoses for the Power Synchronizer

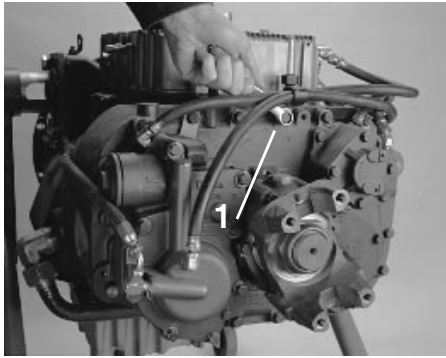

H/49-1

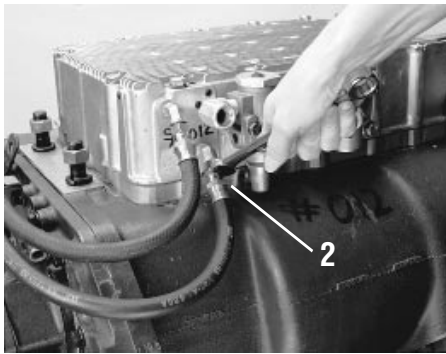

H/45-5

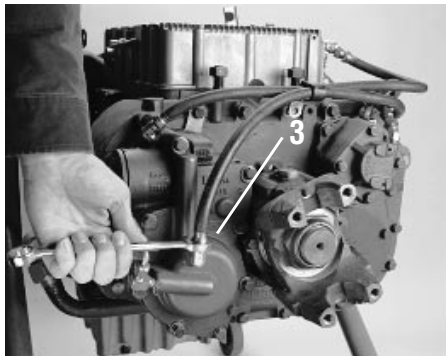

H/49-2

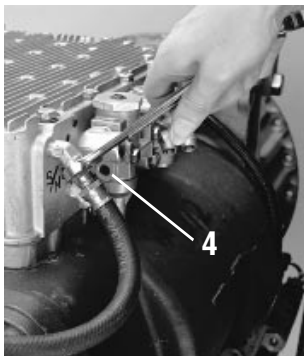

H/45-8

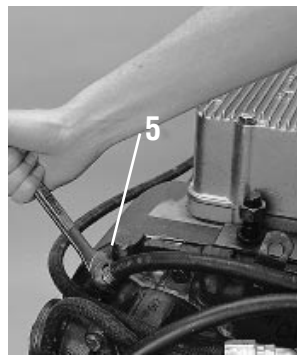

H/45-9

Special Instructions

Before removing the air hoses, label or record their location.

Special Tools

Typical service mechanic tools

To Remove

1. Remove the cap screw holding the air hose clamp to the auxiliary housing.
2. Disconnect the air hose at the shift bar housing power synchronizer disc port (labeled Port A).
3. Disconnect the air supply hose connected to the power synchronizer disc port.
4. Disconnect the air hose at the shift bar housing port air supply hose (labeled Port B).
5. Disconnect the air supply hose connected to the power synchronizer band port.
6. Inspect the air supply fittings on the shift bar housing and the power synchronizer, remove if damaged.

How to Install the Air Supply Hoses for the Power Synchronizer

Special Instructions

Make sure air hoses are not damaged.

Install the air hoses at their proper locations.

All externally threaded $\frac{1}{4}$ " air fittings that are not coated with pre-applied thread sealant must be coated with Eaton sealing material #71209 or equivalent for at least 3 complete and consecutive threads.

For the $\frac{1}{4}$ " I.D. air hoses, install the fixed nut end first.

Special Tools

Typical service mechanic tools

To Install

1. If previously removed, install new air fittings. Tighten to 7-10 Lb_f·ft of torque.
2. Connect one air supply hose end to the power synchronizer band port. Tighten to 7-10 Lb_f·ft of torque.
3. Connect the other end to the shift bar housing cover band port (labeled Port B). Tighten to 7-10 Lb_f·ft of torque.
4. Connect one air supply hose end to the power synchronizer disc port. Tighten to 7-10 Lb_f·ft of torque.
5. Connect the other end to the shift bar housing cover supply port (labeled Port A). Tighten to 7-10 Lb_f·ft of torque.
6. Position the two (2) air supply hoses inside the retaining clamp.
7. Position the clamp on the auxiliary housing by the range cylinder and install the retaining capscrew. Tighten to 35-45 Lb_f·ft of torque.

Final Check

Make sure air lines are not kinked.

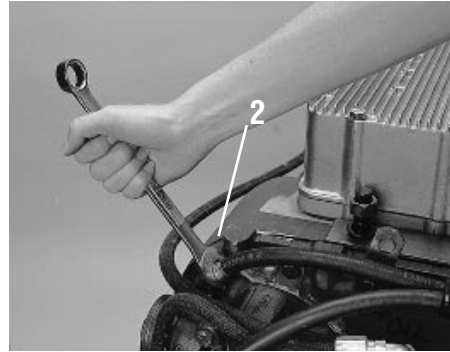

H/45-9

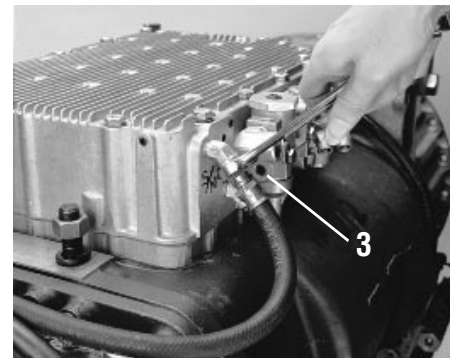

H/45-8

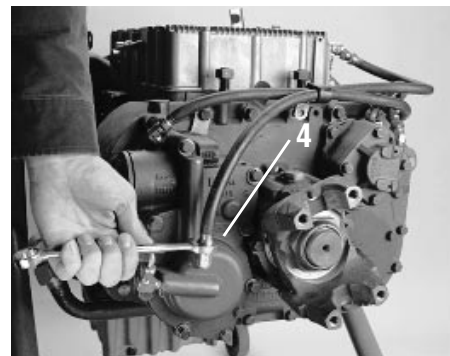

H/49-2



H/45-5

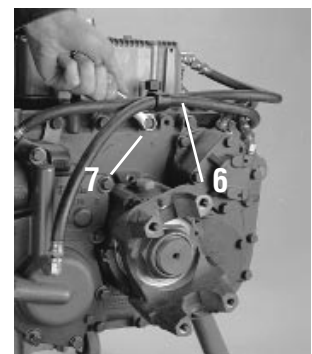

H/49-1

Transmission appearance may differ, procedure is the same.

Air System

How to Remove the Air Supply Hose for the Inertia Brake

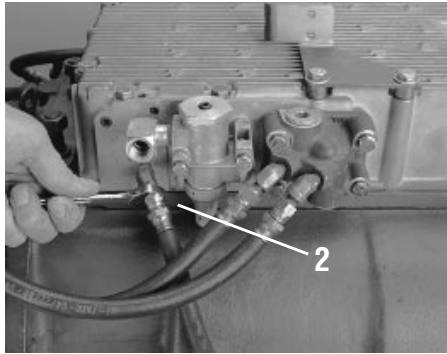

H/51-3

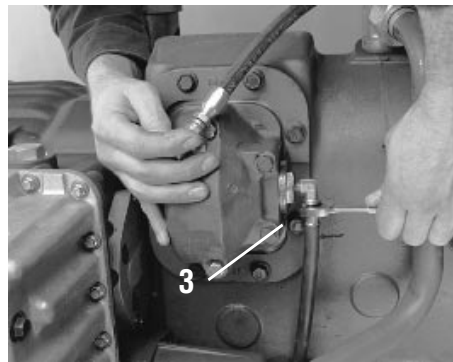

H/51-4

Special Instructions

Before removing the air hose, label or record its location.

Special Tools

Typical service mechanic tools

To Remove

1. If necessary, remove the capscrew holding the air hose to the auxiliary housing.
2. Disconnect the air hose at the shift bar housing inertia brake port (labeled Port A).
3. Disconnect the air supply hose connected to the inertia brake air port.
4. Inspect the air supply fittings on the shift bar housing and the inertia brake, remove if damaged.

How to Install the Air Supply Hoses for the Inertia Brake

Special Instructions

Make sure air hose is not damaged.

Install the air hose at its proper location.

All externally threaded $\frac{1}{4}$ " air fittings that are not coated with pre-applied thread sealant must be coated with Eaton sealing material #71209 or equivalent for at least 3 complete and consecutive threads.

For the $\frac{1}{4}$ " I.D. air hoses, install the fixed nut end first.

To install the hose, the air filter/regulator must be in position.

Special Tools

Typical service mechanic tools

To Install

1. If previously removed, install new air fittings. Tighten to 7-10 Lb_f·ft of torque.
2. The pipe plug in Port B is tighten to 7-10 Lb_f·ft of torque.
3. Connect the air supply hose to the inertia brake air port. Tighten to 7-10 Lb_f·ft of torque.
4. Connect the other end to the shift bar housing inertia brake port (labeled Port A). Tighten to 7-10 Lb_f·ft of torque.
5. When necessary, position the air supply hose inside the retaining clamp.
6. Position the clamp on the 6 bolt PTO cover and install the retaining capscrew. Tighten to 35-45 Lb_f·ft of torque.

Final Check

Make sure air lines are not kinked.

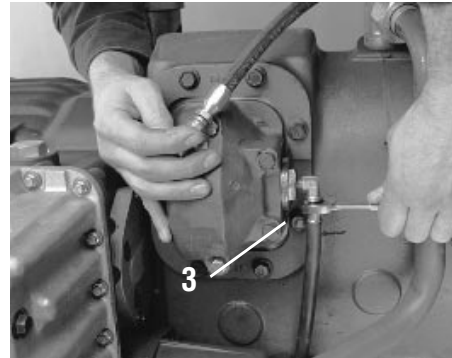

H/51-4

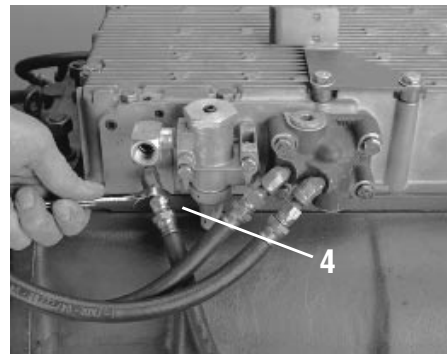

H/51-3

Air System

How to Remove the Air Supply Hoses for LO and HI Range

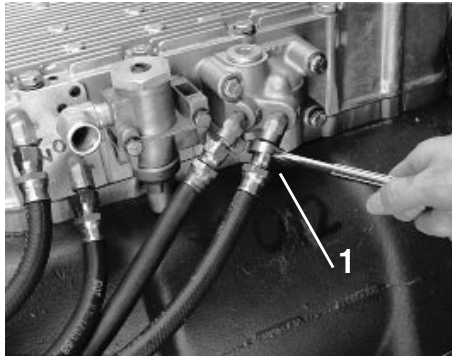

H/45-1

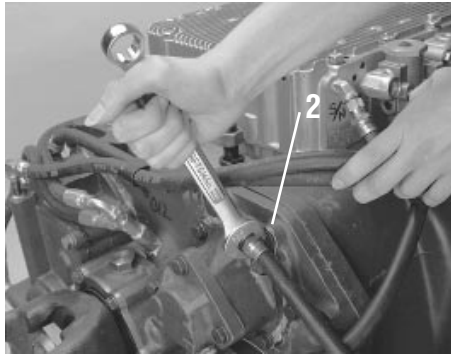

H/45-2

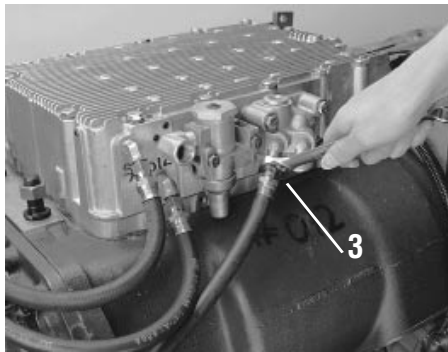

H/45-3

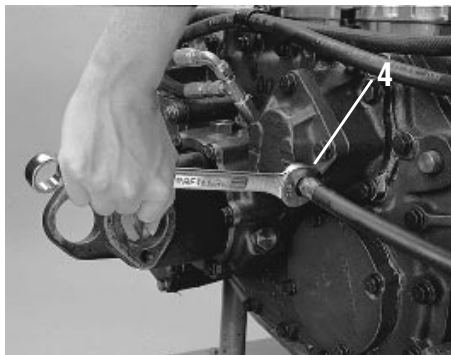

H/45-4

Special Instructions

Before removing the air hoses, label or record their location.

Special Tools

Typical service mechanic tools

To Remove

1. Disconnect the slave valve LO range supply port air hose.
2. Disconnect the air supply hose connected to the range cylinder LO range supply port.
3. Disconnect the slave valve HI range supply port air hose.
4. Disconnect the air supply hose connected to the range cylinder HI range supply port.
5. Inspect the air supply fittings on the shift bar housing and the range cylinder, remove if damaged.

How to Install the Air Supply Hoses for LO and HI Range

Special Instructions

Make sure air hoses are not damaged.

Install the air hoses at their proper locations.

All externally threaded $\frac{1}{4}$ " air fittings that are not coated with pre-applied thread sealant must be coated with Eaton sealing material #71209 or equivalent for at least 3 complete and consecutive threads.

For the $\frac{1}{4}$ " I.D. air hoses, install the fixed nut end first.

To install the hoses, the air filter/regulator must be in position.

Special Tools

Typical service mechanic tools

To Install

1. If previously removed, install new air supply fittings. Tighten to 7-10 Lb_f.ft of torque.
2. Connect one air supply hose end to the range cylinder HI range supply port. Tighten to 7-10 Lb_f.ft of torque.
3. Connect the other end to the slave valve HI range supply port. Tighten to 7-10 Lb_f.ft of torque.
4. Connect one air supply hose end to the range cylinder LO range supply port. Tighten to 7-10 Lb_f.ft of torque.
5. Connect the other end to the slave valve LO range supply port. Tighten to 7-10 Lb_f.ft of torque.

Final Check

Make sure air lines are not kinked.

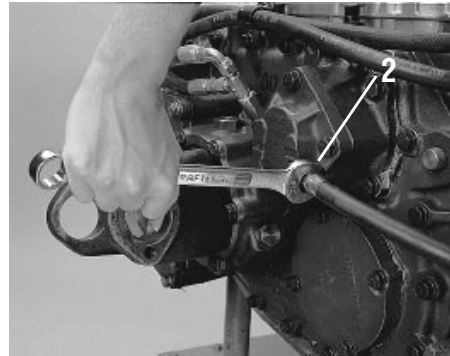

H/45-4

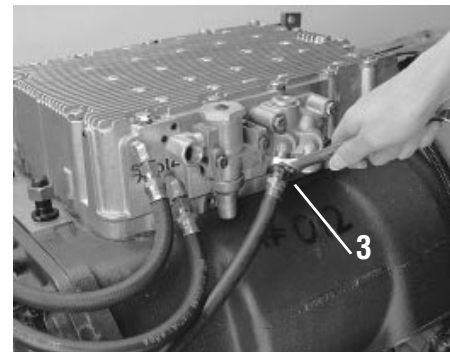

H/45-3



H/45-2

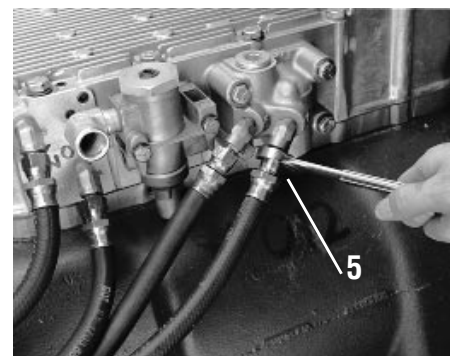

H/45-1

Transmission appearance may differ, procedure is the same.

Air System

How to Remove the Air Filter/Regulator

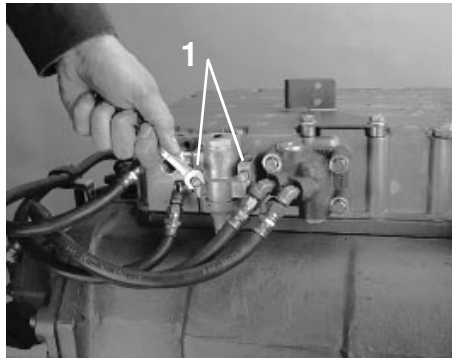

H/49-3

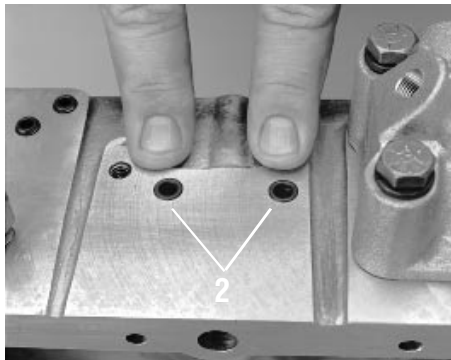

H/04-4

Special Instructions

The air filter/regulator has two (2) O-rings located between the filter/regulator and the shift bar housing cover.

Special Tools

Typical service mechanic tools needed

To Remove

1. From the air filter/regulator, remove the two (2) capscrews.
2. From the shift bar cover, remove the two (2) O-rings.
3. Inspect the O-rings for cracks or distortion.
4. Inspect the air fittings on the air filter/regulator, remove if damaged.

How to Install the Air Filter/Regulator

Special Instructions

The air filter/regulator has two (2) O-rings located between the filter/regulator and the shift bar housing. Use a small amount of grease to hold the O-rings in place, if the shift bar housing is installed on the transmission.

Special Tools

Typical service mechanic tools needed

To Install

1. If previously removed, install new air supply fittings. Tighten the larger fitting to 14-20 Lb_f.ft of torque and the smaller to 7-10 Lb_f.ft of torque.
2. On the shift bar cover, position the two (2) O-rings.
3. Over the O-rings, position the air filter/regulator.
4. Apply Eaton/Fuller Sealant #71205 or equivalent to the two (2) retaining capscrews.
5. Install the two (2) retaining capscrews, tighten to 8-12 Lb_f.ft of torque.

Final Check

Make sure the capscrews are properly torqued.

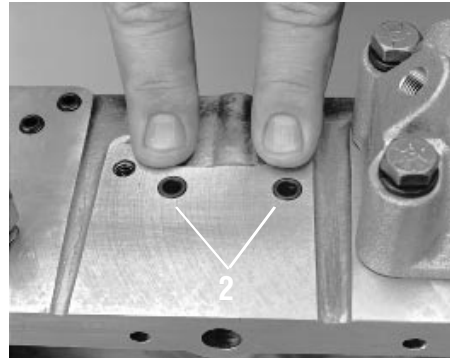

H/04-4

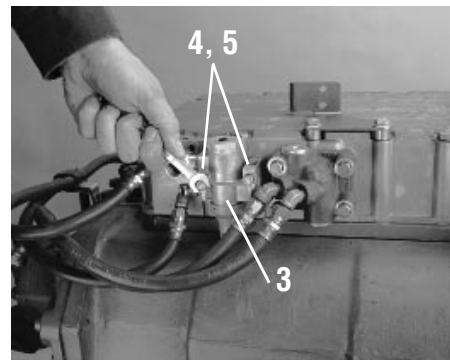

H/49-3

Air System

How to Remove a Slave Valve

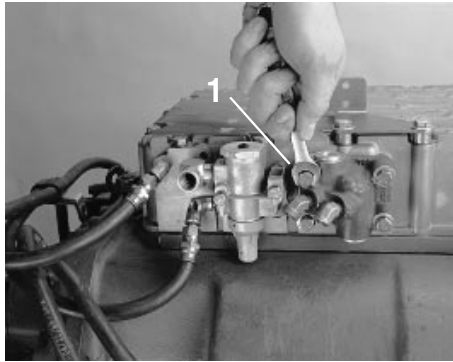

H/49-4

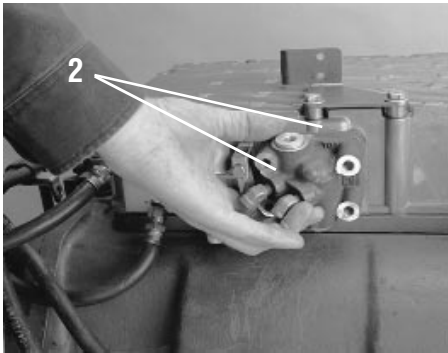

H/49-5

Special Instructions

The air lines should be removed.

Special Tools

Typical service mechanic tools needed

To Remove

1. Remove the retaining cap screws.
2. From the shift bar cover, remove the slave valve and gasket. You may need to use a plastic hammer to remove.
3. Thoroughly clean gasket area. Do not get gasket material or dirt in the shift bar housing ports or valve ports.
4. If the insert valves have been damaged, remove the plugs and insert valves.

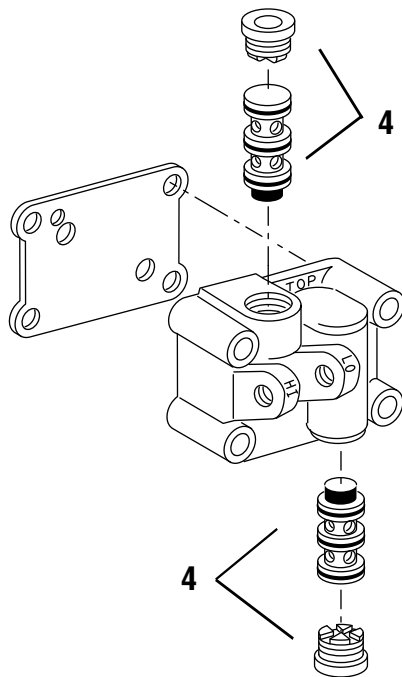

Range Valve

How to Install a Slave Valve

Special Instructions

Make sure gasket mounting areas are clean.

Special Tools

Typical service mechanic tools needed

To Install

1. If previously removed, install new insert valves. Tighten to 20-25 Lb_f·ft of torque.
2. Position the corresponding new gasket on the slave valve mounting surface.
3. Position the slave valve over the gasket.
4. Apply Eaton/Fuller Sealant #71205 or equivalent to the retaining capscrews.
5. Install the retaining capscrews. Tighten to 8-12 Lb_f·ft of torque.

Final Check

Make sure the retaining capscrews are properly torqued.

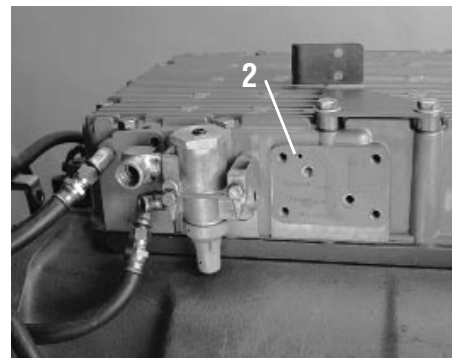
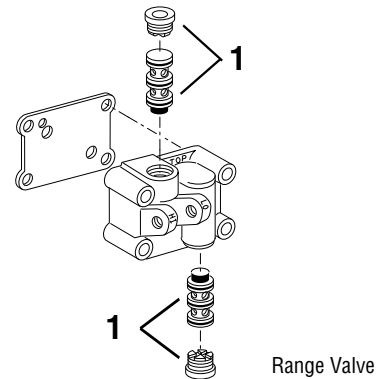

H/49-6

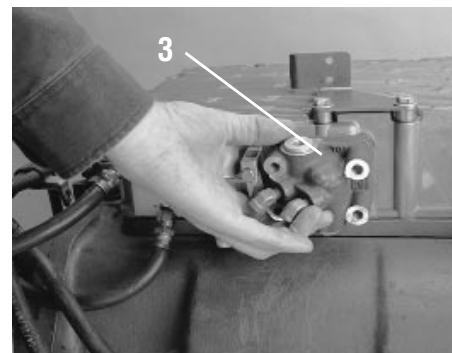

H/49-5

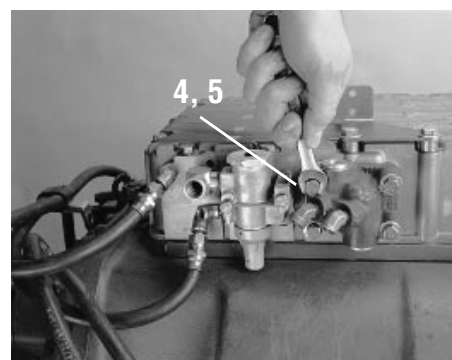

H/49-4

Transmission appearance may differ, procedure is the same.

Lube System

How to Remove the Lube Supply Hose for the Power Synchronizer

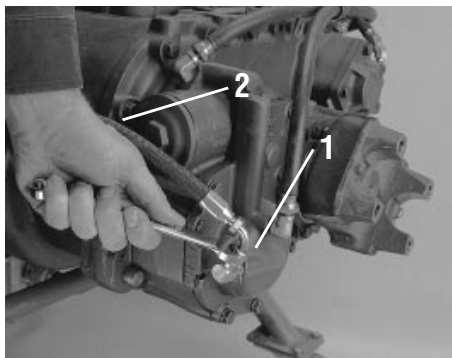

H/49-7

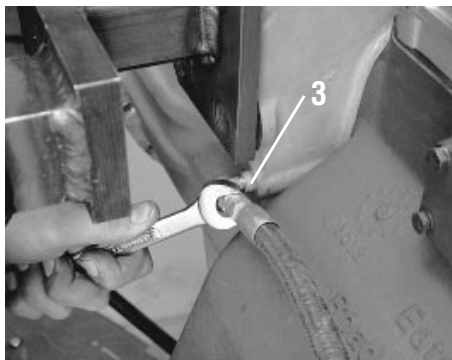

H/43-5

Special Instructions

Before removing the lube hose, label or record its location.

Special Tools

Typical service mechanic tools

To Remove

1. Disconnect the lube hose from the power synchronizer.
2. To ease in removal, remove the cap screw and clamp holding the hose to the auxiliary section.
3. Disconnect the lube supply line connected to the converter housing.
4. Inspect the fitting and connector, remove if damaged.
5. Inspect the oil restrictor behind the connector, remove if damaged.

How to Install the Lube Supply Hose for the Power Synchronizer

Special Instructions

Make sure lube hose is not damaged.
Install the lube hose at its proper location.

Special Tools

Typical service mechanic tools

To Install

1. If previously removed, install a new oil restrictor. Tighten to 20-30 Lb_f·in of torque.
2. If previously removed, install a new connector and/or fitting. Tighten to 14-20 Lb_f·ft of torque.
3. Connect one lube supply hose end to the converter housing lube port. Tighten to 15-20 Lb_f·ft of torque.
4. Connect the other end to the power synchronizer lube port. Tighten to 15-20 Lb_f·ft of torque.
5. Install the capscrew and clamp to hold the hose to the auxiliary section. Tighten to 35-45 Lb_f·ft of torque.



H/43-5

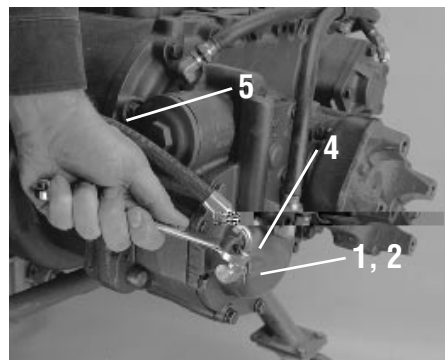

H/49-7

Final Check

Make sure air hoses are not kinked or twisted.

Lube System

How to Remove the Lube Supply Hose for the Inertia Brake

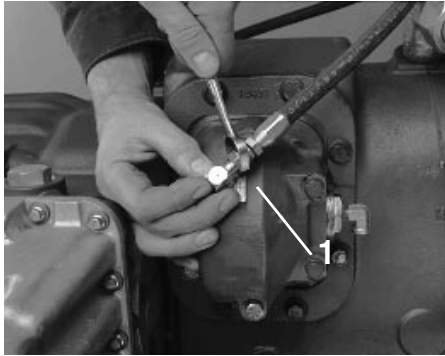

H/51-5

Special Instructions

Before removing the lube hose, label or record its location.

Special Tools

Typical service mechanic tools

To Remove

1. Disconnect the lube supply hose connected to the inertia brake.
2. Disconnect the lube supply hose at the torque converter housing lube port.
3. Inspect the fittings, remove if damaged.
4. Inspect the oil restrictor behind the torque converter fitting, remove if damaged.



H/43-5

How to Install the Lube Supply Hoses for the Inertia Brake

Special Instructions

Make sure lube hose is not damaged.
Install the lube hose at its proper location.

Special Tools

Typical service mechanic tools

To Install

1. If previously removed, install a new oil retractor. Tighten to 20-30 Lb_f·in of torque.
2. If previously removed, install new connectors. Tighten to 15-20 Lb_f·ft of torque.
3. Connect one lube supply hose end to the converter housing lube port.
4. Connect the other lube supply hose end to the inertia brake.

Final Check

Make sure air hoses are not kinked.

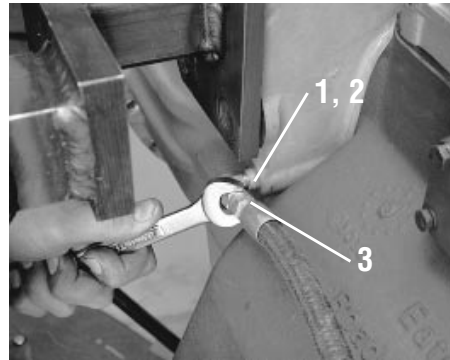

H/43-5

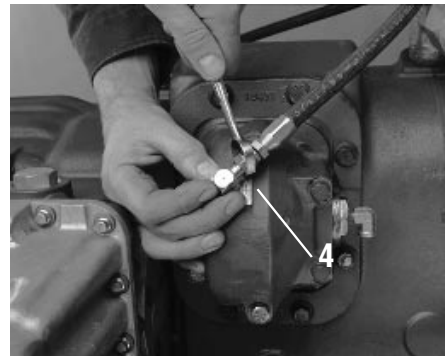

H/51-5

Lube System

How to Remove the Oil Tube and Oil Pan/Strainer

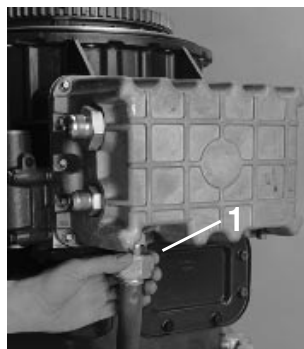

H/49-8

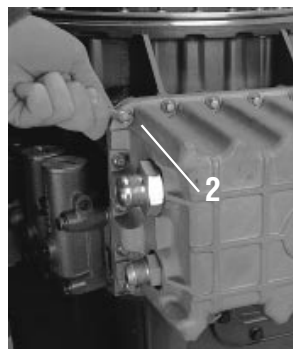

H/49-9

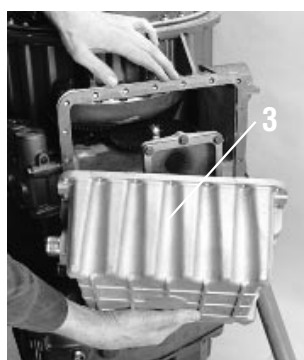

H/50-1

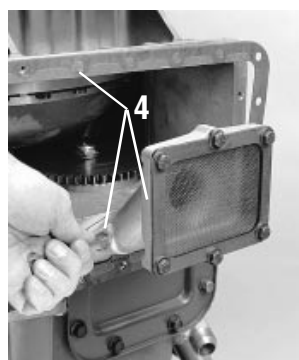

H/50-2

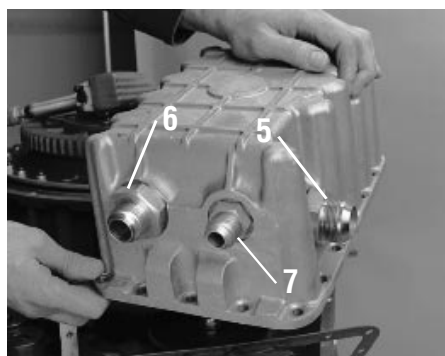

H/50-4

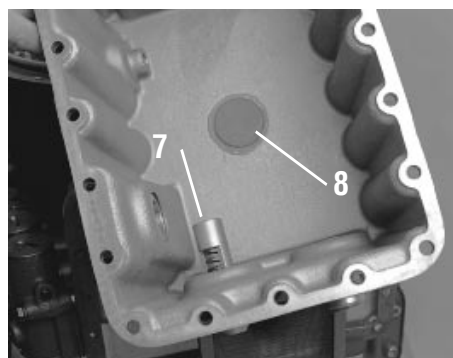

H/50-3

Special Instructions

Special Tools

Typical service mechanic tools
5/16" - 12 Point socket

To Remove

1. Disconnect the return tube from the oil pan and transmission.
2. From the oil pan, remove the retaining cap screws.
3. Remove the oil pan.
4. Remove the retaining cap screws, oil transfer tube, and oil pan gasket.
5. Inspect the oil return adapter tube, remove if damaged.
6. Inspect the dip stick adaptor fitting, remove if damaged.
7. Inspect the cooler back pressure valve, if damaged replace.
8. Clean the oil pan magnet.
9. Clean and inspect the strainer. Replace, if damaged.
10. Inspect the return tube fitting on the transmission, remove if damaged.

How to Install the Oil Tube and Oil Pan/Strainer

Special Instructions

If the magnet needs to be replaced, use adhesive #71210 or equivalent and cover the entire mating surface.

Special Tools

Typical service mechanic tools

To Install

1. If previously removed, install the strainer capscrews. Tighten to 5-7 Lb_f·ft of torque.
2. Position a new oil pan gasket and the oil transfer tube.
3. Install the two (2) retaining capscrews. Tighten the screws to 14-20 Lb_f·ft of torque.
4. Position the oil pan.
5. Install the retaining capscrews. Tighten the screws to 14-20 Lb_f·ft of torque.
6. If previously removed, install the dip stick adaptor O-ring and fitting. Tighten to 34-48 Lb_f·ft of torque.
7. If previously removed, install the oil return adaptor O-ring and adaptor. Tighten to 34-48 Lb_f·ft of torque.
8. If previously removed, install a new return tube fitting on the transmission. Tighten to 60-75 Lb_f·ft of torque.
9. Install the return tube on the sump pan. Tighten to 60-75 Lb_f·ft of torque.

Final Check

Make sure all connector are properly torqued.

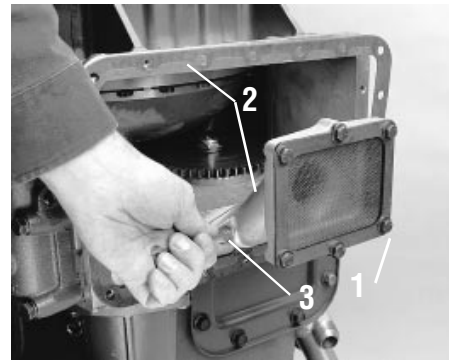

H/50-2

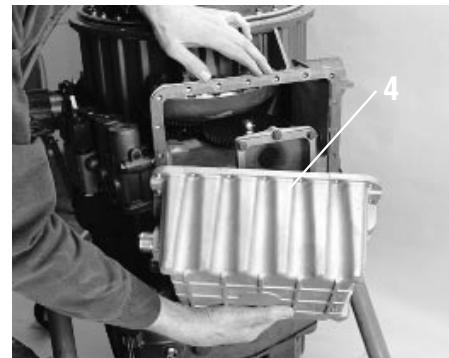

H/50-1

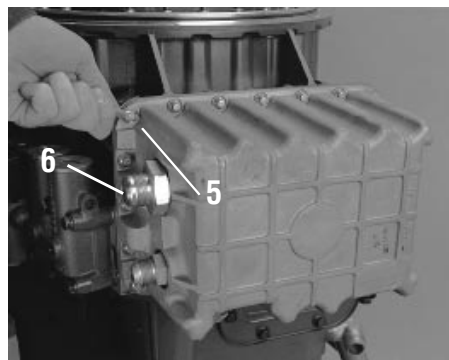

H/49-9

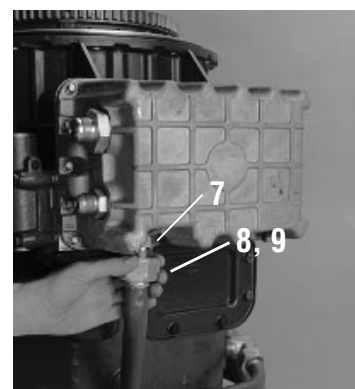

H/49-8

Transmission appearance may differ, procedure is the same.

Lube System

How to Remove the Oil Filter

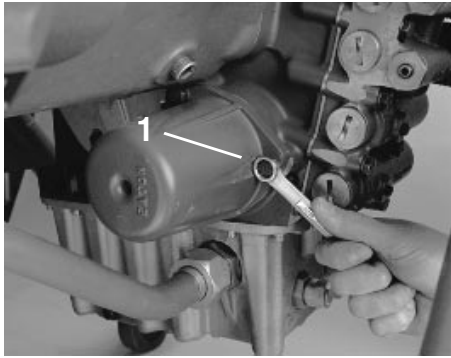

H/50-5

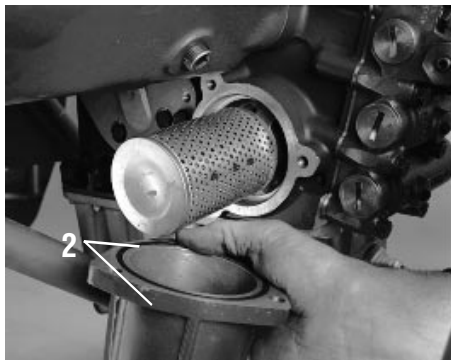

H/50-6

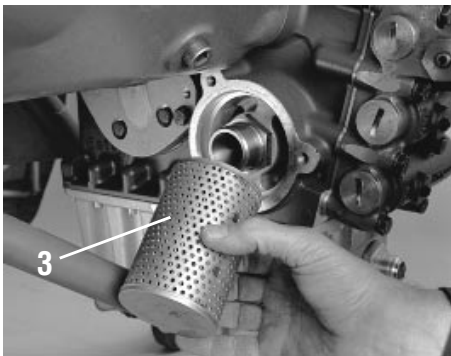

H/50-7

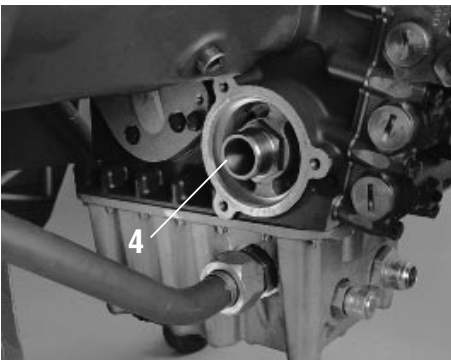

H/50-8

Special Instructions

Special Tools

Typical service mechanic tools

To Remove

1. Remove the three (3) retaining capscrews.
2. Remove the oil filter housing and O-ring seal.
3. Remove the oil filter by pulling it straight off.
4. Inspect the oil filter nipple, remove if damaged.

How to Install the Oil Filter

Special Instructions

Depending on the orientation (vertical or horizontal), grease may be needed to hold the seal ring on the filter housing.

Special Tools

Typical service mechanic tools

To Install

1. If removed, apply hydraulic sealant and replace the oil filter nipple. Tighten to 34-48 Lb_f·ft of torque.
2. Install the oil filter on the oil filter nipple.
3. Position the O-ring seal on the oil filter housing.
4. Position the oil filter housing over the oil filter.
5. Install the three (3) capscrews. Tighten to 26-32 Lb_f·ft of torque.

Final Check

Make sure the capscrews are properly torqued.

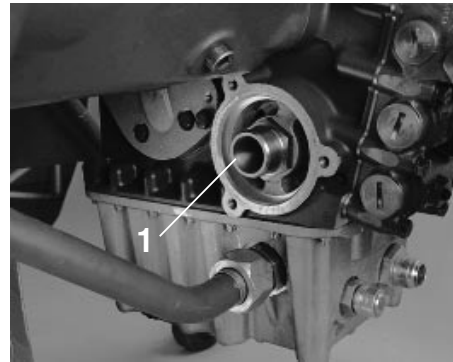

H/50-8

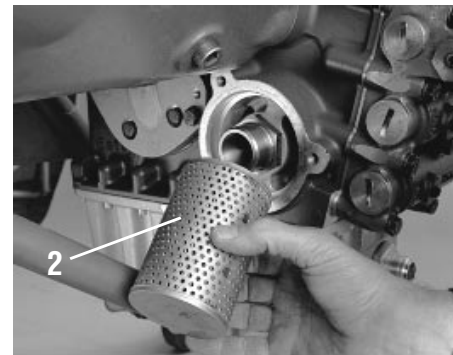

H/50-7



H/50-6

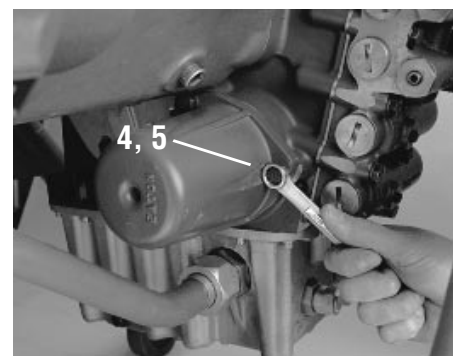

H/50-5

Transmission appearance may differ, procedure is the same.

Synchronizer Systems

How to Remove the Power Synchronizer

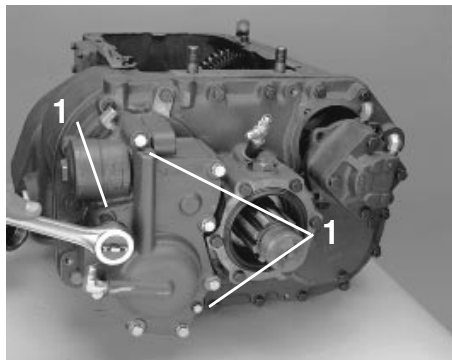

H/28-2

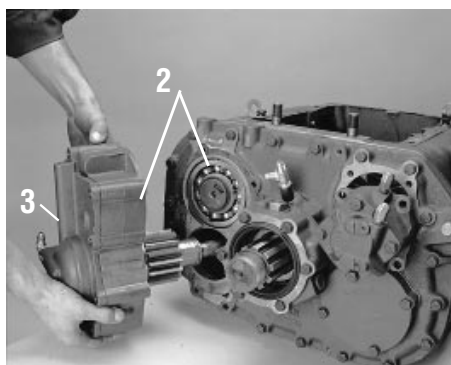

H/28-3

Special Instructions

There are different capscrew lengths, note their location.

The hoses need to be disconnected.

Special Tools

Typical service mechanic tools

To Remove

1. From the power synchronizer, remove the mounting capscrews.
2. Remove the power synchronizer and gasket.
3. Inspect the roll pin in the middle mounting position.

How to Remove the Inertia Brake

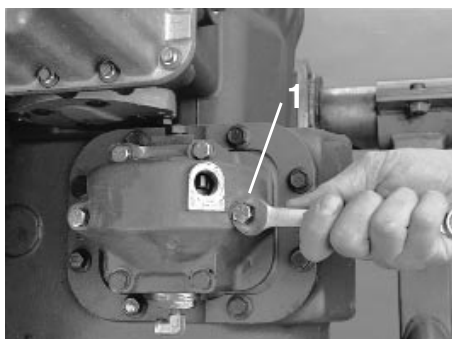

H/51-6

Special Instructions

There are different capscrew lengths, note their location.

The hoses need to be disconnected.

The removal/replacement procedure is "typical". Your inertia brake may be installed in a "6 bolt" or "rotated 6 bolt" PTO configuration. The process for the removal/replacement is the same. Refer to the Illustrated Parts Lists for further pictures.

Special Tools

Typical service mechanic tools

To Remove

1. From the inertia brake, remove the mounting capscrews.
2. Remove the inertia brake and gasket.
3. Inspect the fittings, remove if damaged.

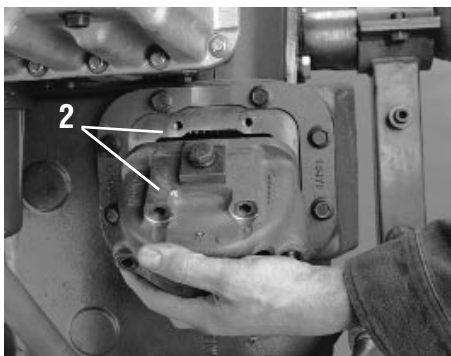

H/51-7

Transmission appearance may differ, procedure is the same.

Synchronizer Systems

How to Install the Power Synchronizer

Special Instructions

There are different capscrew lengths, make sure they are in their proper location.

Special Tools

Typical service mechanic tools

To Install

1. If previously removed, install a new roll pin in the middle mounting position.
2. Position the power synchronizer and gasket.
3. Install the power synchronizer mounting capscrews. Tighten to 35-45 Lbf·ft of torque. The middle capscrew uses a washer.

Final Check

Make sure the capscrews are properly torqued.

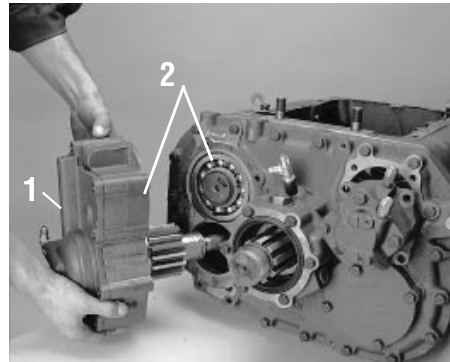

H/28-3

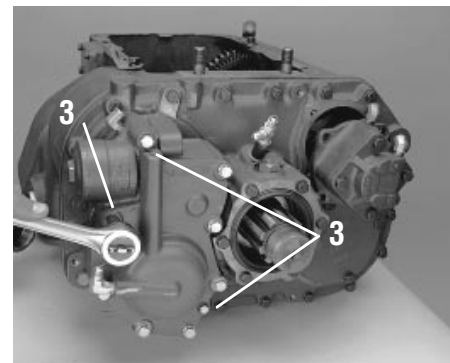

H/28-2

How to Install the Inertia Brake

Special Instructions

There are different capscrew lengths, note their location.

Special Tools

Typical service mechanic tools

To Remove

1. If previously removed, install new fittings. Tighten the 1/8" elbow to 7-10 Lbf·ft of torque. Tighten the 90° elbow to 14-20 Lbf·ft of torque.
2. Position the inertia brake and gasket with washers.
3. Install the inertia brake mounting capscrews. Tighten to 35-45 Lbf·ft of torque.

Final Check

Make sure the capscrews are properly torqued.

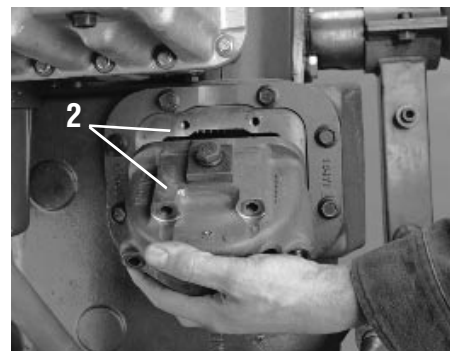

H/51-7

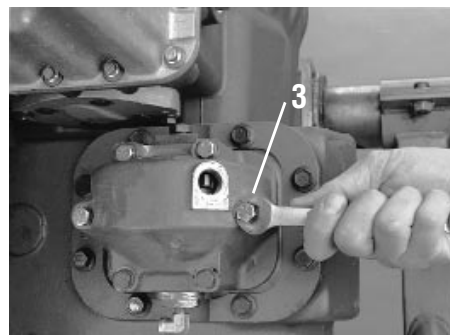

H/51-6

Transmission appearance may differ, procedure is the same.

Shift Bar Housing

How to Remove the Shift Bar Housing Cover

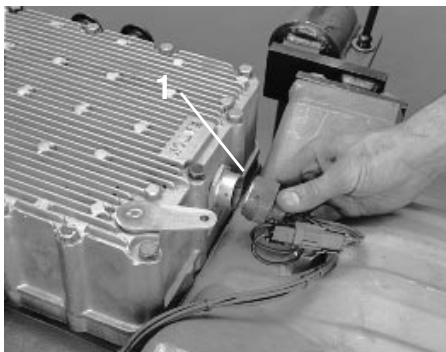

H/42-8

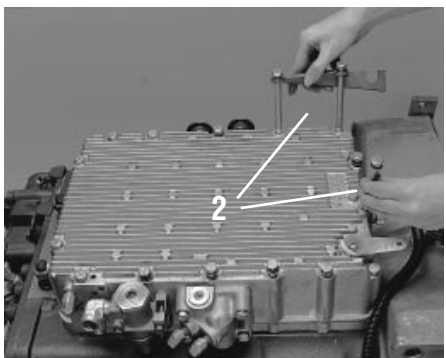

H/46-7

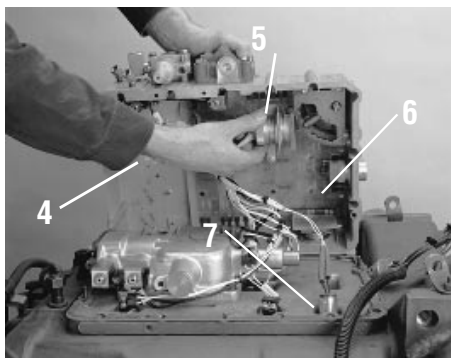

H/51-1

Special Instructions

Before removing the shift bar housing cover, the air hoses must be disconnected.

Removal of the air filter/regulator and the slave valve can be done before removing the shift bar cover.

There are different capscrew lengths, note their location.

The shift bar housing cover is a non-serviceable assembly.

CAUTION: Do not touch the electronic components.

Cover and set aside in a clean area.

Special Tools

Typical service mechanic tools needed

To Remove

1. Disconnect the torque converter wire harness.
2. Remove the shift bar housing cover capscrews and shift cable bracket.
3. Lift the shift bar housing cover up vertically past the alignment pins.
4. Carefully tip the cover on its side.
5. Disconnect the internal autoshift harness connector.
6. Remove the shift bar housing cover.
7. Remove the shift bar housing cover gasket.
8. On the shift bar housing back side, inspect the breather, bushing, and pipe plug, remove if damaged.

Shift Bar Housing

How to Install the Shift Bar Housing Cover

Special Instructions

Be careful when lowering the shift bar housing cover that the harness wires do not get pinched between the cover and housing or autoshifter.

There are different capscrew lengths, install in the correct location.

Special Tools

Typical service mechanic tools needed

To Install

1. Position a new gasket on the shift bar housing.
2. Carefully set the shift bar cover on its side on the shift bar housing top.
3. Connect the internal autoshifter harness connector.
4. Use the alignment pins and set the shift bar housing cover in place.
5. Apply Eaton/Fuller Sealant #71205 or equivalent to the retaining capscrews or use dyna seals™.
6. Install the retaining capscrews with washers. Tighten to 23-30 Lb_f·ft of torque.
7. Install the shift cable bracket with washers. Tighten to 23-30 Lb_f·ft of torque.
8. If previously remove, install the shift cable lever nut. Tighten to 23-30 Lb_f·ft of torque.
9. Connect the converter wire harness to the shift bar housing cover.
10. If previously removed, install a new bushing and breather. Tighten to 5-7 Lb_f·ft of torque.
11. If previously removed, install a new pipe plug. Tighten to 14-20 Lb_f·ft of torque.

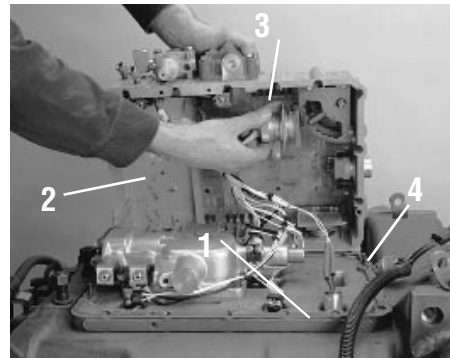

H/51-1

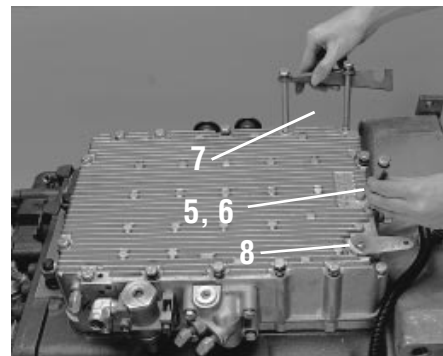

H/46-7

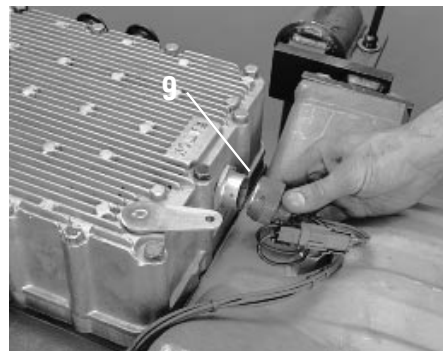

H/42-8

Final Check

Make sure the converter wire harness is connected.

Shift Bar Housing

How to Remove the Autoshift Harness

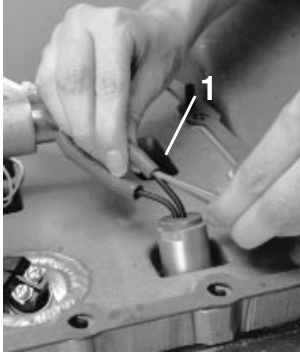

H/46-9

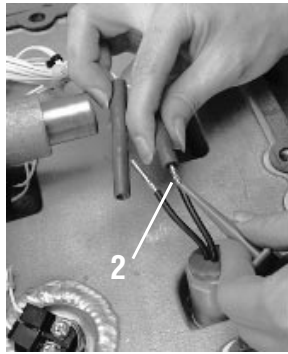

H/47-1

Special Instructions

Make sure all labels are in the right place.

Note locations and positions of terminals and connectors.

Use the removal tool included on the harness to disconnect the in-line connectors.

Special Tools

Typical service mechanic tools needed

To Remove

1. Disconnect the 2 pin in-line connector from the input shaft speed pick-up using the removal tool located on the autoshifter harness. Slide the tool along the wire into the insert cavity until it engages the contact and resistance is felt. The contact retaining clip will be in the unlocked position.
2. Pull the contact wire assembly out of the connector.
3. Repeat steps 1 and 2 to disconnect the output shaft speed pick-up.
4. On the shift bar housing, loosen the four (4) ball switch screws on the range ball switches and remove the autoshift harness terminals.
5. Remove the four (4) hex head screws retaining the autoshifter and remove the autoshifter, gasket and O-ring.
6. Remove the four (4) nuts from the four (4) autoshift solenoids.
7. Remove the brackets, retainers, and coils.
8. Loosen the six (6) screws that hold the harness on the three (3) autoshifter ball switches and remove the harness terminals.

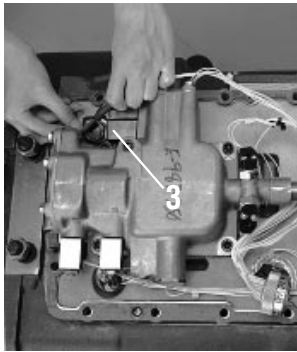

H/47-2

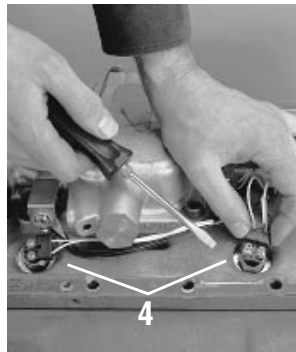

H/51-2

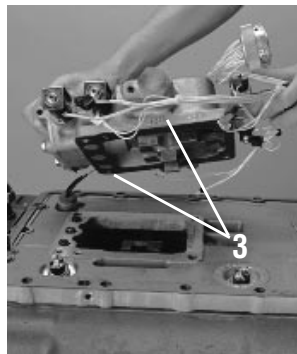

H/47-6

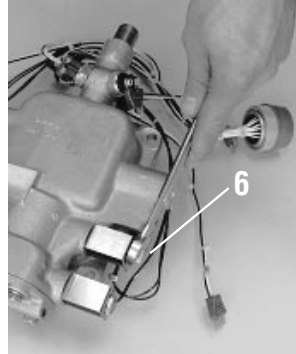

H/09-1

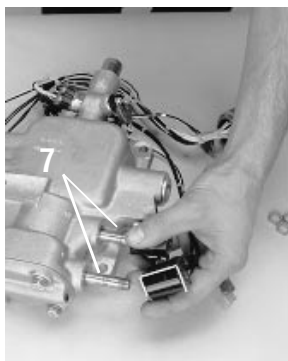

H/09-2

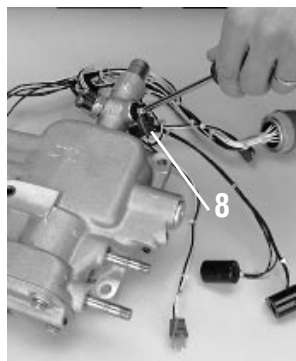

H/09-3

Shift Bar Housing

How to Install the Autoshift Harness

Special Instructions

Make sure all labels are in the right place.

Note locations and positions of terminals and connectors.

When connecting the in-line connectors, make sure the wire locks into position. To check, pull gently on the wires; if the wires resist they are locked.

Special Tools

Typical service mechanic tools needed

To Install

1. Install the three harness (3) ball switch terminals (labeled S1, S2, and S3) mounted on the autoshift housing end. Tighten to 14-20 Lb_f-ft of torque.
2. Install the four (4) brackets (with square end out) and coils.
3. Install the four (4) nuts on the solenoids. Tighten to 15-20 Lb_f-in of torque.
4. Install autoshifter gasket and O-ring.
5. Install the autoshifter with four (4) hex head bolts with washers. Tighten to 20-30 Lb_f-ft of torque.
6. Position the autoshift harness S4 lead ends under the washers in the HI range ball switch.
7. Tighten the screws to 15-20 Lb_f-in of torque.
8. Position the autoshift harness S5 lead ends under the washers in the LO range ball switch.
9. Tighten the screws to 15-20 Lb_f-in of torque.
10. Connect the 2 pin in-line connector for the input shaft speed pick-up by inserting the contact wire inside the insert cavity. Check that they are locked.
11. Connect the 2 pin in-line connector for the output shaft speed pick-up by inserting the contact wire inside the insert cavity. Check that they are locked.

Final Check

Make sure the autoshift harness is connected exactly like the line drawing shown for "How to Install the Autoshifter Assembly".

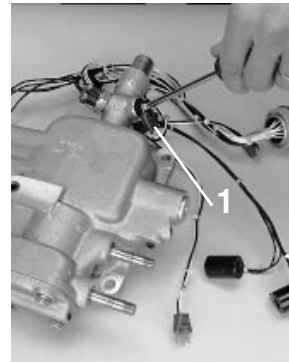

H/09-3

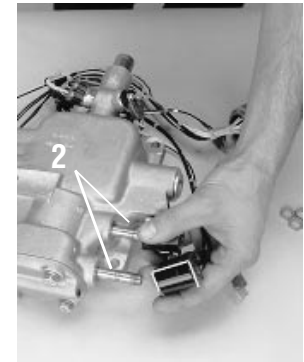

H/09-2

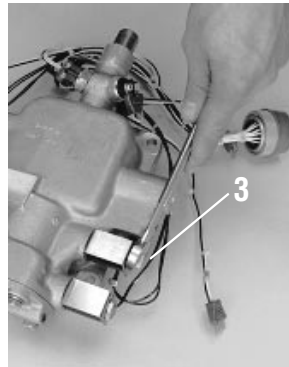

H/09-1

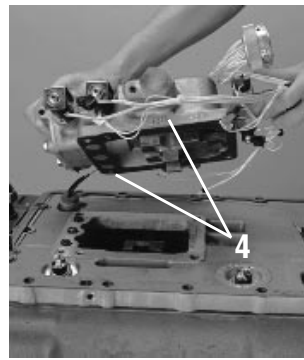

H/47-6

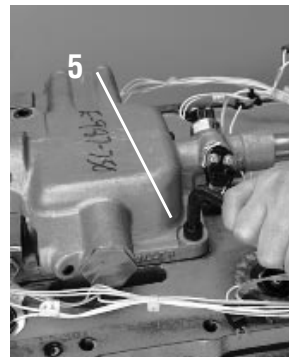

H/47-5

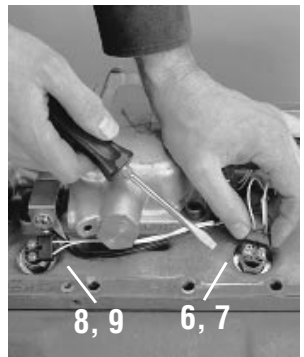

H/51-2

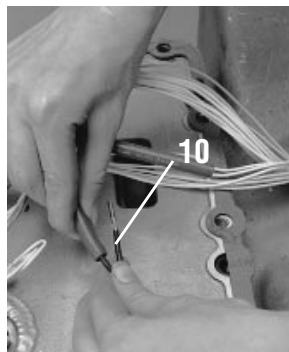

H/48-4

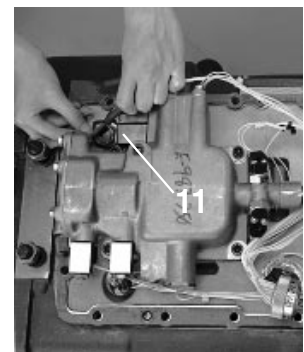

H/47-2

Transmission appearance may differ, procedure is the same.

Shift Bar Housing

How to Remove the Autoshift Assembly

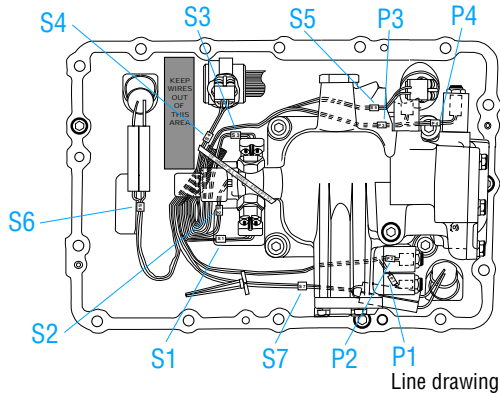

Special Instructions

Make sure all labels are in the right place.

Note locations and positions of terminals and connectors.

Use the removal tool included on the harness to disconnect the in-line connectors.

The air hoses, shift bar cover assembly, and autoshift harness connectors must be disconnected.

Special Tools

Typical service mechanic tools needed

To Remove

1. Disconnect the 2 pin in-line connector from the input shaft speed pick-up using the removal tool. Slide the tool along the wire into the insert cavity until it engages the contact and resistance is felt. The contact retaining clip will be in the unlocked position.
2. Pull the contact wire assembly with tool out of the connector.
3. Repeat steps 1 and 2 to disconnect the output shaft speed pick-up.
4. On the shift bar housing, loosen the two switch screws on the range switches and remove the autoshift harness lead ends.
5. Remove the four (4) allen head screws and washers from the autoshift assembly.
6. Remove the autoshift assembly and harness.
7. Remove the air supply O-ring and gasket.

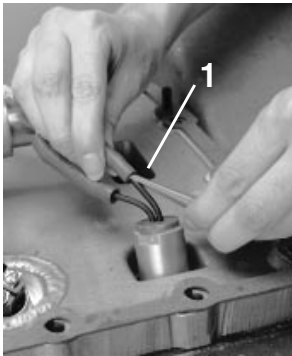

H/46-9

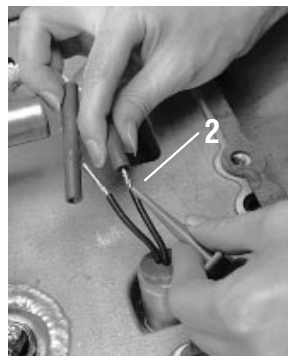

H/47-1

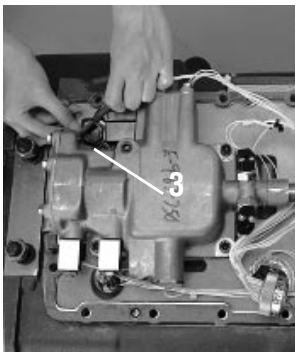

H/47-2

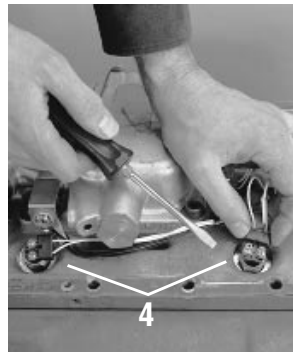

H/51-2



H/47-5

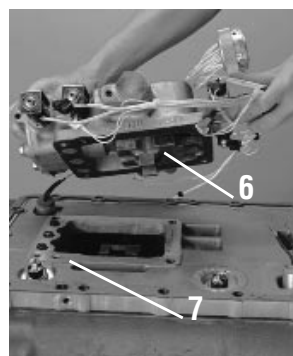

H/47-6

Shift Bar Housing

How to Install the Autoshift Assembly

Special Instructions

Make sure all labels are in the right place.

Note locations and positions of terminals and connectors.

When connecting the in-line connectors, make sure the wire locks into position. To check, pull gently on the wires; if the wires resist they are locked.

Make sure air supply O-ring and gasket are in position.

Special Tools

Typical service mechanic tools needed

To Install

1. Install the autoshifter air supply O-ring and gasket.
2. Position the autoshifter assembly, align shift finger with transmission and harness.
3. Install the autoshifter with the four (4) hex head bolts with washers. Tighten to 20-30 Lb_f·ft of torque.
4. Position the autoshift harness S4 lead end under the washers in the HI range ball switch.
5. Tighten the screws to 15-20 Lb_f·in of torque.
6. Position the autoshift harness S5 lead end under the washers in the LO range ball switch.
7. Tighten the screws to 15-20 Lb_f·in of torque.
8. Connect the 2 pin in-line connector for the input shaft speed pick-up by inserting the contact wire inside the insert cavity. Check that they are locked.
9. Connect the 2 pin in-line connector for the output shaft speed pick-up by inserting the contact wire inside the insert cavity. Check that they are locked.

Final Check

Make sure the autoshift harness is connected exactly like the line drawing shown at the top.

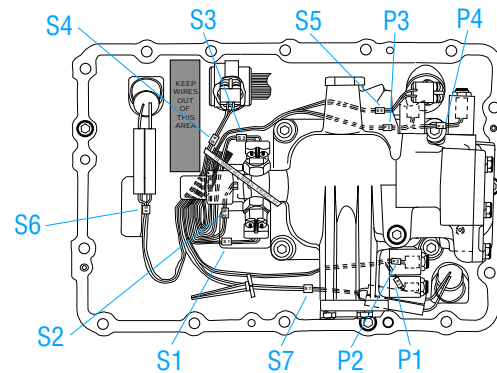

Line drawing

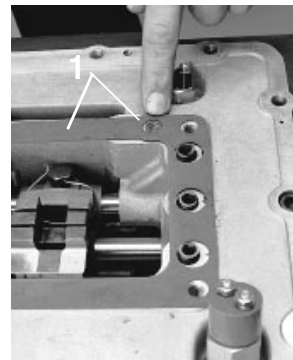

H/08-9

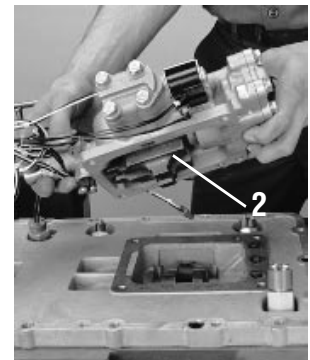

H/08-7

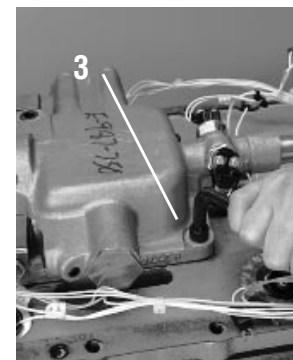

H/47-5

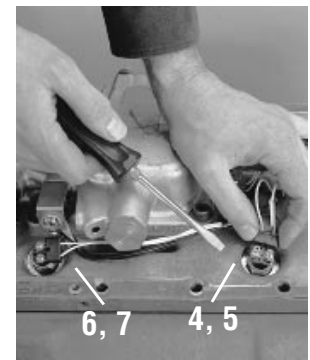

H/51-2

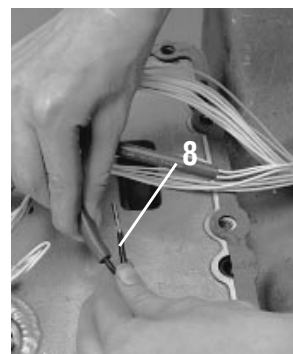

H/48-4



H/47-2

Transmission appearance may differ, procedure is the same.

Shift Bar Housing

How to Remove the Shift Bar Housing

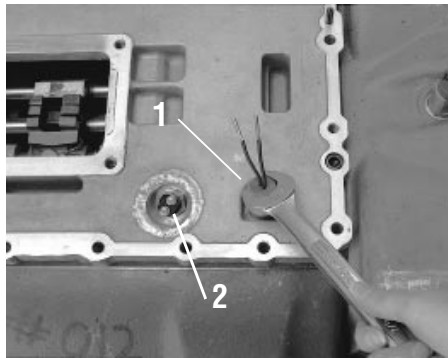

H/47-7

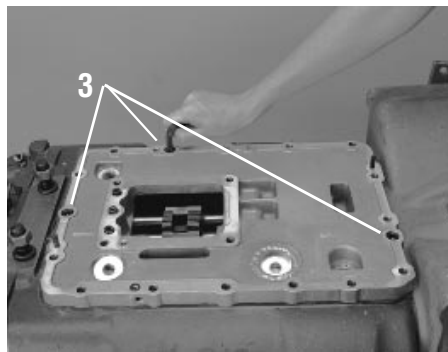

H/47-9

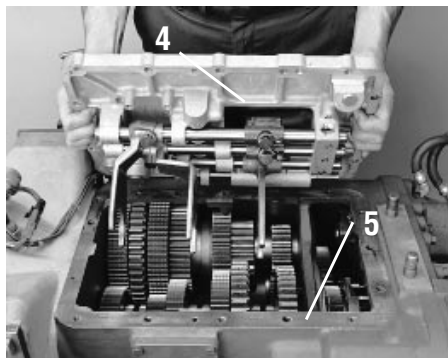

H/11-9

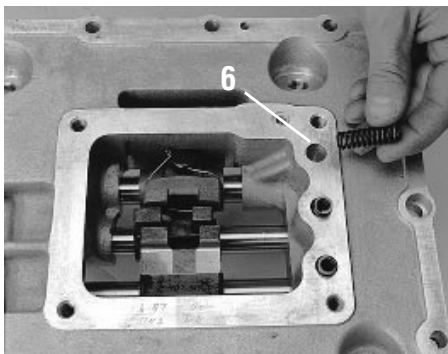

H/12-6

Special Instructions

Before removing the shift bar housing, the shift bar housing cover and autoshifter must be removed.

Special Tools

Typical service mechanic tools needed

To Remove

1. Inspect the input and output shaft magnetic speed sensors, remove if damaged or defective.
2. Inspect the ball switches, remove if defective or damaged.
3. From the shift bar housing, remove the three (3) Allen head screws.
4. Remove the shift bar housing.
5. Remove the gasket and clean all mounting surfaces of gasket material.
6. If the three (3) sets of tension springs and balls from the housing top bores are loose, tilt the assembly and remove them.

Shift Bar Housing

How to Install the Shift Bar Housing

Special Instructions

When installing the shift bar housing, make sure the auxiliary section is in LO range.

Make sure the shift bar housing yokes are in the neutral position.

Special Tools

Typical service mechanic tools needed

To Install

1. Place the shift bars in the neutral position.
2. Place the mainshaft sliding clutches in the neutral position.
3. Position a new shift bar housing gasket on the shift bar housing mounting surface.
4. As you install the shift bar housing, make sure the yokes fit into the corresponding sliding clutch slots.
5. Install the three (3) interlock balls in the housing bores.
6. Install the three (3) tension springs in the housing bores.
7. Install the three (3) allen head screws in the shift bar housing rim. Tighten to 35-45 Lb_f·ft of torque.
8. If previously removed, install the two (2) magnetic speed sensors. Tighten to 14-20 Lb_f·ft of torque. The output shaft speed pick-up on RTO-11109B-ATE has a gasket.
9. If previously removed, install the range switches with gaskets. Tighten to 14-20 Lb_f·ft of torque.

Final Check

Make sure the capscrews are properly torqued.

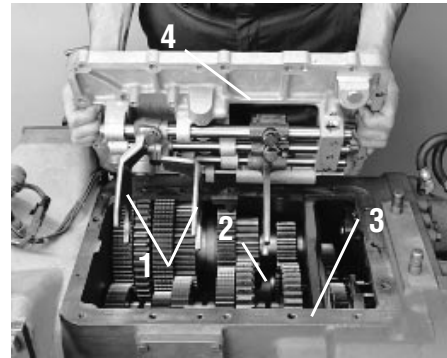

H/11-9

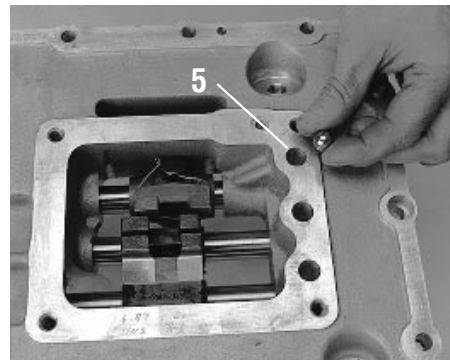

H/12-7

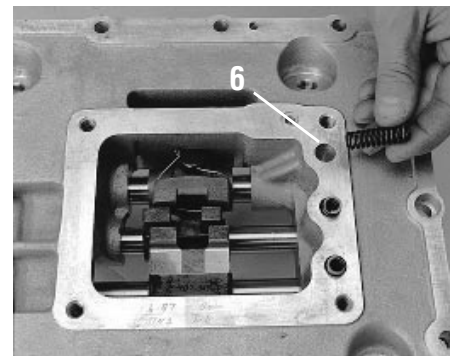

H/12-6

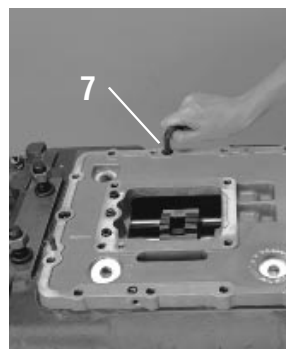

H/47-9

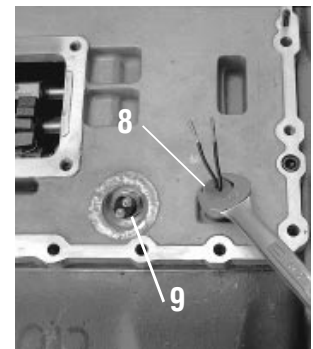

H/47-7

Transmission appearance may differ, procedure is the same.

Torque Converter

How to Remove the Torque Converter

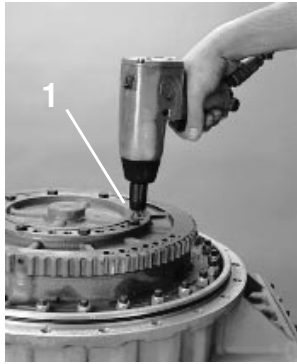

H/15-2

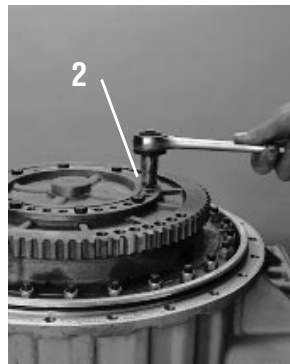

FIXED H/15-1



H/21-7



H/21-8



H/15-6

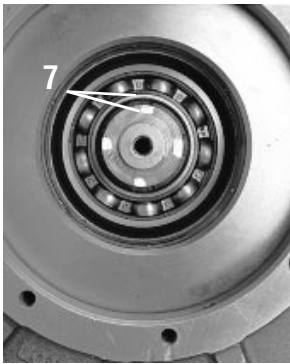

H/51-8

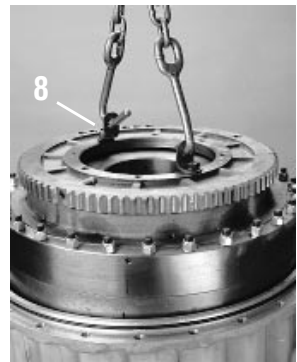

H/15-9



H/52-1

Special Instructions

Removal of the torque converter is done with the transmission in the vertical position.

Special Tools

Typical service mechanic tools are needed
A hoist with a lifting chain

To Remove

1. Remove the pilot retaining capscrews.
2. Insert two bolts in the tapped holes and tighten evenly to work the pilot out.
3. Remove and discard the O-ring on the pilot.
4. Remove the two (2) seal rings on the pilot.
5. Remove the two (2) piston rings from the input shaft.
6. From the input shaft, remove the torque converter retaining snap ring.
7. Mark the location of the input shaft lube slots on the input shaft end.
8. Install two (2) lifting eyes in the torque converter pilot holes directly across from each other. Lift the torque converter straight up.
9. Remove the seal ring from the torque converter stator support.

How to Install the Torque Converter

Special Instructions

Installation of the torque converter is done with the transmission in the horizontal position.

When installing the torque converter pilot, do not damage the seal rings, O-ring, or input shaft seal rings.

Special Tools

Typical service mechanic tools are needed.

To Install

1. Prepare the stator support seal for installation. Cross seal ends, be careful not to crease seal. Seal ends should touch when relaxed.
 2. Apply thin coat of lubriplate to seal ring and install on stator support.
 3. Install two (2) lifting eyes in the torque converter pilot holes.
 4. Align the marked input shaft lube slots, slowly set the torque converter down the input shaft until the snap ring groove is visible. You may need to wiggle the converter gently.
 5. On the input shaft install the torque converter retaining snap ring in the snap ring groove.
 6. Apply a thin coat of lubriplate to the input shaft piston rings and install on the input shaft. Ring ends need to be interlocked. Ring ends need to be interlocked.
 7. Prepare the pilot seal rings for installation. Cross seal ends, be careful not to crease seal. Seal ends should touch when relaxed. Apply thin coat of lubriplate to seal rings and install on pilot.
 8. To install a new O-ring, apply thin coat of lubriplate and place in the O-ring groove.
 9. Align torque converter pilot with bolt holes and gently tap with hammer to seat.
- Note:** You can only use pilot O-ring once. If pilot is misaligned, install new O-ring.
10. Install the retaining capscrews, tighten to 23-30 Lb_f-ft of torque.

Final Check

Make sure the retaining capscrews are properly torqued.

Transmission appearance may differ, procedure is the same.

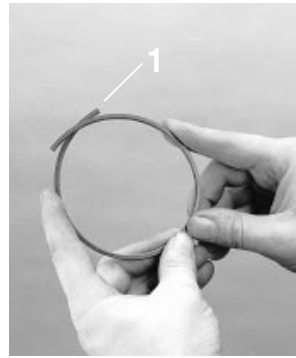

H/51-9



H/52-1

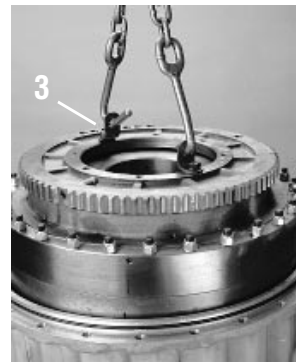

H/15-9



H/51-8



H/15-6



H/21-8



H/21-7

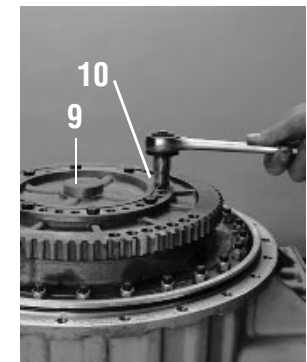

H/15-1



Torque Converter

How to Remove the Hydraulic Valve

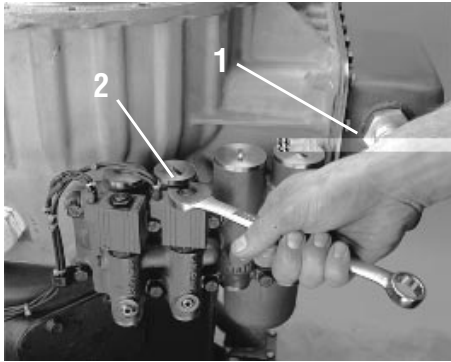

H/22-1

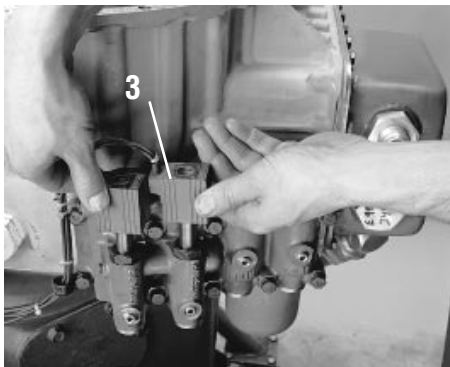

H/22-2

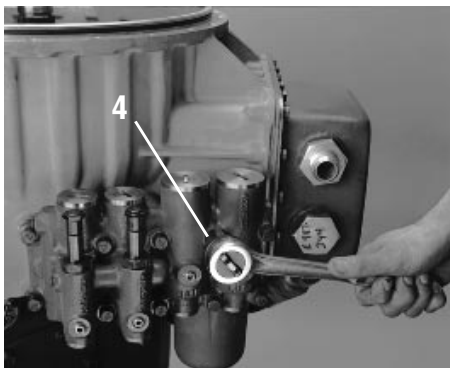

H/22-3

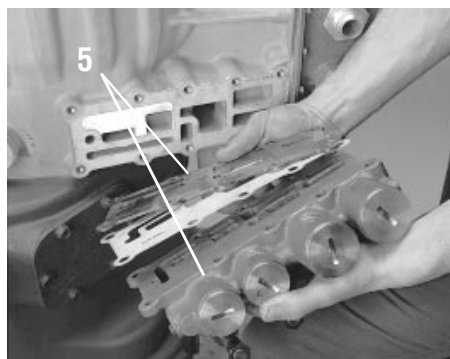

H/22-4

Special Instructions

Removal of the hydraulic valve can be vertically or horizontally.

Special Tools

Typical service mechanic tools are needed

To Remove

1. Loosen the dip stick tube nut and remove the dip stick tube.
2. Remove the two (2) retaining nuts from the magnetic coils.
3. Remove the two (2) magnetic coils from the hydraulic valve. Check for distortion or cracks, if damaged, replace.
4. Remove the hydraulic valve mounting capscrews and socket head screws.
5. Remove the hydraulic valve, mounting plate, and gaskets.

How to Install the Hydraulic Valve

Special Instructions

Installation of the hydraulic valve can be vertically or horizontally.

Liberal apply Eaton Lubricant #71230 or equivalent to the hydraulic valve stems where the magnetic coils sit.

Special Tools

Typical service mechanic tools are needed.

To Install

1. Install the hydraulic valve gaskets, mounting plate, and hydraulic valve. Gaskets marked "housing" and "valve" must be installed in their respective locations.
2. Install the hydraulic valve mounting capscrews and socket headscrews. Tighten to 26-32 Lb_f·ft of torque.
3. Install the two (2) magnetic coils on the hydraulic valve stems, wires towards the front.
4. Install the two (2) retaining nuts on the magnetic coils. Tighten to 30 Lb_f·in of torque.
5. Install the dip stick tube and tighten the dip stick tube nut. Tighten to 35-45 Lb_f·ft of torque.

Final Check

Make sure the capscrews and headscrews are properly torqued.

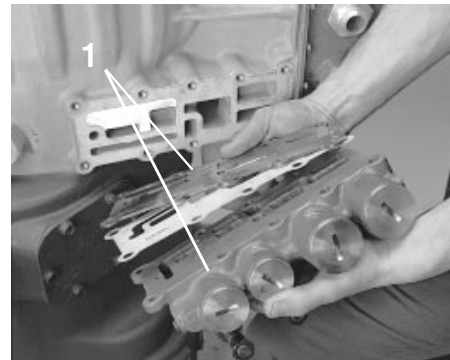

H/22-4

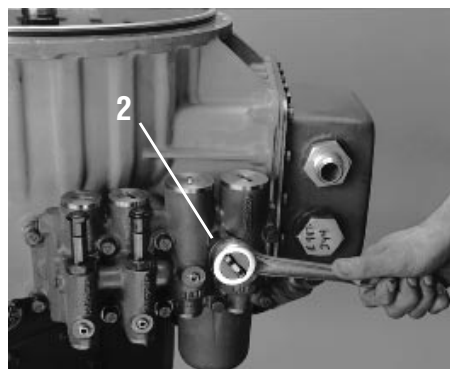

H/22-3

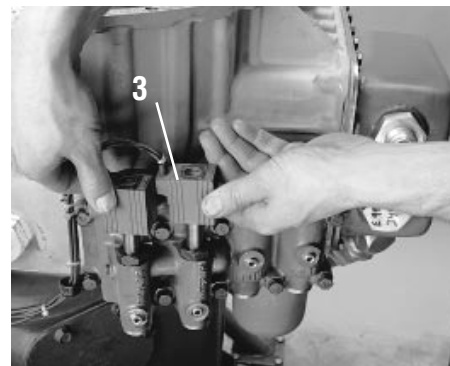

H/22-2

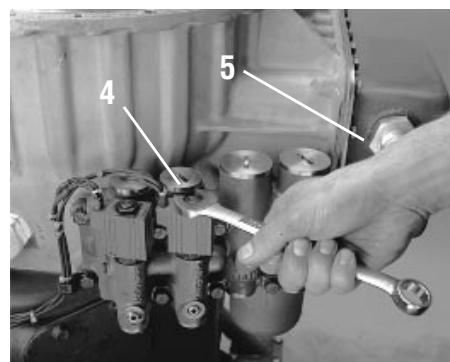

H/22-1

Transmission appearance may differ, procedure is the same.

Torque Converter

How to Remove the Dip Stick

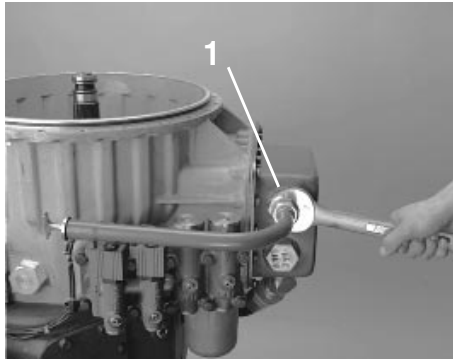

H/21-9

Special Instructions

Removal of the dip stick can be done in the vertical or horizontal position.

Special Tools

Typical service mechanic tools are needed

To Remove

1. Loosen the dip stick tube nut and remove the dip stick tube.
2. Inspect the dip stick connector, remove if damaged.

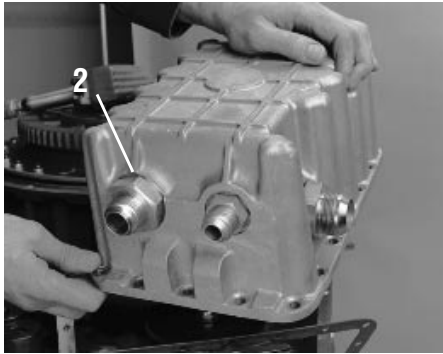

H/50-4

How to Install the Dip Stick

Special Instructions

Installation of the dip stick can be done in the vertical or horizontal position.

Special Tools

Typical service mechanic tools are needed.

To Install

1. If previously removed, install the dip stick connector O-ring and connector. Tighten to 34-48 Lb_f-ft of torque.
2. Install the dip stick tube and tighten the dip stick tube nut. Tighten to 35-45 Lb_f-ft of torque.

Final Check

Make sure the parts are properly torqued.

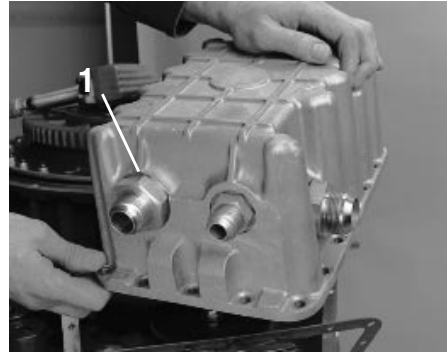

H/50-4

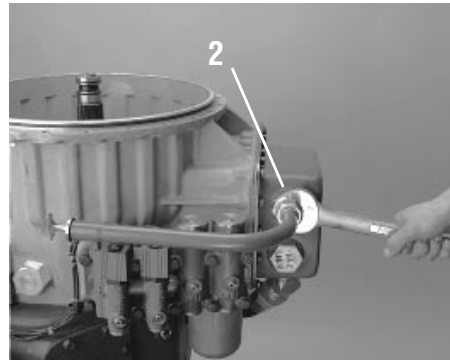

H/21-9

Torque Converter

How to Remove the Torque Converter Housing



H/52-1

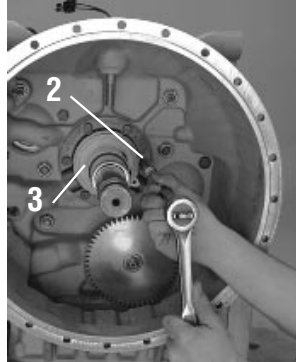

H/25-7

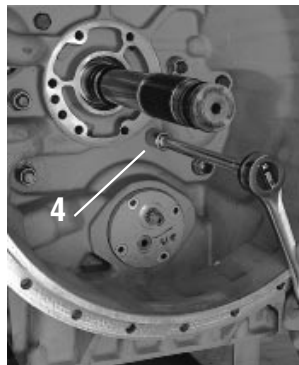

H/26-3

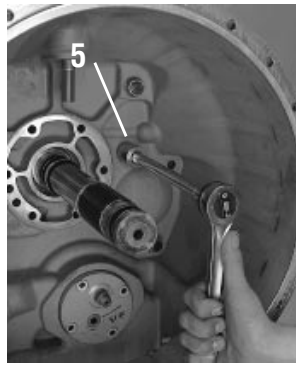

H/26-4

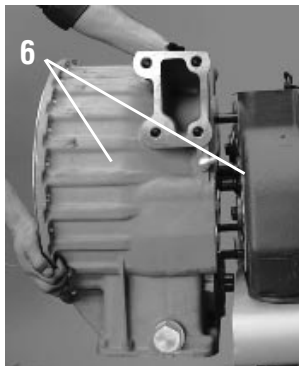

H/26-5

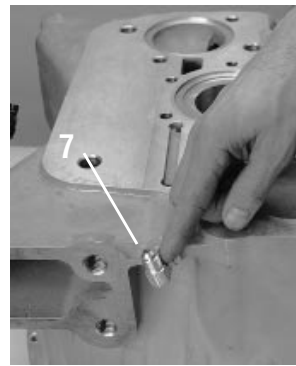

H/27-4

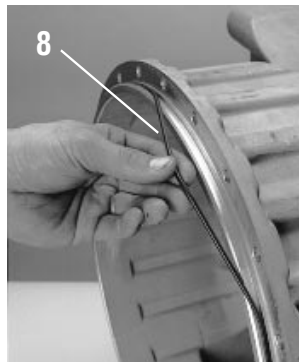

H/27-5

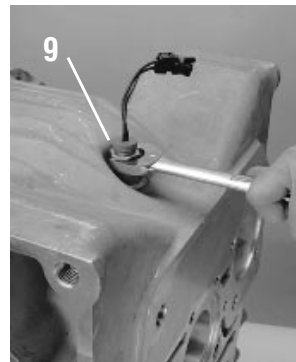

H/27-6

Special Instructions

Removal of the torque converter housing is done in the vertical position.

Disconnect the torque converter and harness from ECU.

Disconnect the hydraulic valve.

Remove the synchronizer system lube line, the sump return tube, and the dipstick.

Special Tools

Typical service mechanic tools are needed

To Remove

1. Remove the stator support seal ring.
2. From the stator support, remove the retaining capscrews.
3. Remove the stator support and gasket.
4. Remove the torque converter housing retaining capscrews with washers.
5. Remove the torque converter housing nuts with washers.
6. Remove the torque converter housing and gasket from the transmission case.
7. Inspect the synchronizer system lube elbow adaptor, remove if damaged.
8. Inspect the torque converter housing seal, remove if damaged.
9. Remove the magnetic sensor. Inspect the O-ring, remove if damaged.
10. Inspect the stator support O-ring, replace if cracked or distorted. The O-ring is not used on 9109 Models.
11. Remove all piston rings on the input shaft.

How to Install the Torque Converter Housing

Special Instructions

Installation of the torque converter housing is done in the vertical position.

Apply Eaton Lubricant #71214 to stator support O-ring. Cover entire surface. The O-ring is not used on 9109 Models.

Special Tools

Typical service mechanic tools are needed.

To Install

1. If removed, install a new O-ring and the magnetic sensor. Tighten to 14-20 Lb_f.ft of torque.
2. If removed, replace the torque converter housing seal.
3. If removed, install the synchronizer system lube O-ring and elbow. Tighten to 14-20 Lb_f.ft of torque.
4. Position the torque converter housing gasket on the transmission case.
5. Install the torque converter housing over the gasket.
6. Install the nuts with washers. Tighten to 130-170 Lb_f.ft of torque.
7. Install the capscrews with washers. Tighten to 70-80 Lb_f.ft of torque.
8. Install the 3 piston rings in the input shaft base. Ring ends need to be interlocked.
9. If previously removed, apply lubrication and install the O-ring in the stator support bottom. The O-ring is not used on 9109 Models.
10. Make sure the stator support pressure ports are aligned and position the gasket and support.
11. Install the stator support retaining capscrews. Tighten to 34-45 Lb_f.ft of torque.
12. Cross the stator support seal ring ends. Be careful not to crease the seal. When finished, seal ring ends should touch when relaxed. Apply a thin film of lubriplate and install.

Final Check

Make sure the retaining capscrews are properly torqued.

Transmission appearance may differ, procedure is the same.

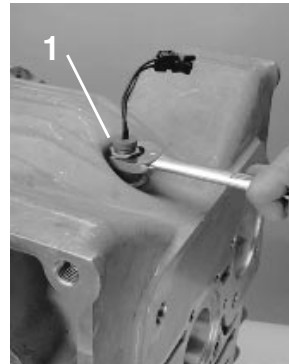

H/27-6

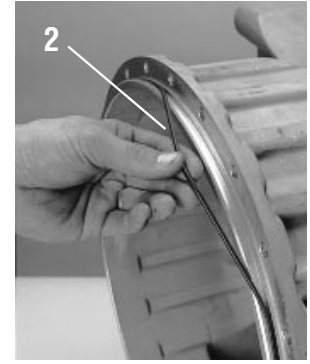

H/27-5

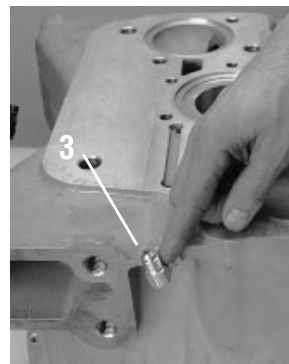

H/27-4

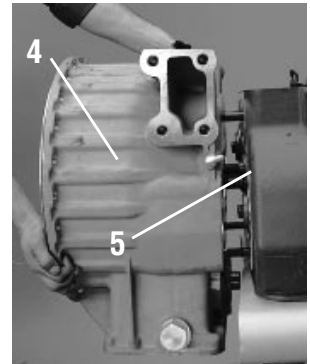

H/26-5

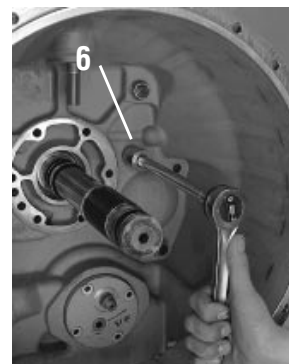

H/26-4

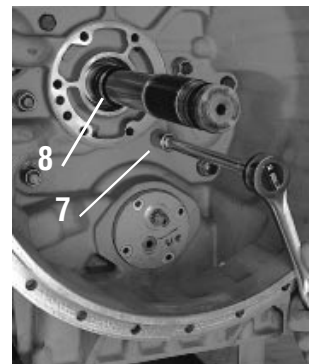

H/26-3

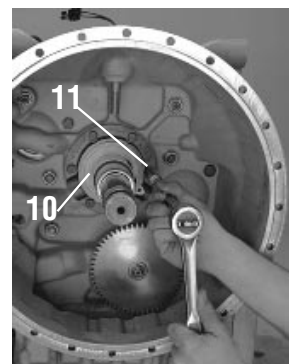

H/25-7



H/52-1

Torque Converter

How to Remove the Oil Pump



H/26-1

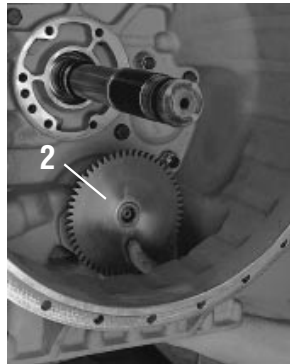

H/26-2

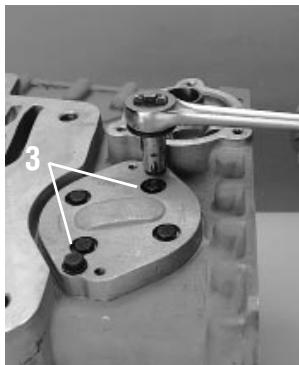

H/26-8

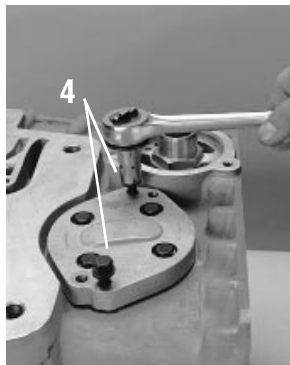

H/26-9

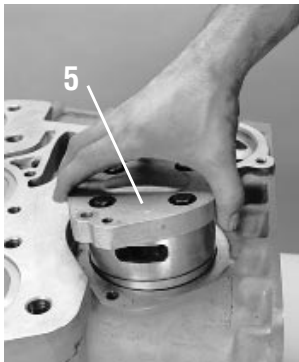

H/27-1

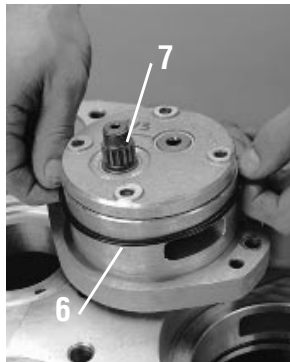

H/27-2

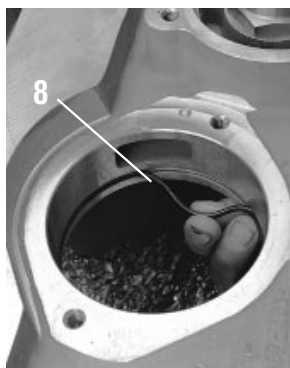

H/27-3

Special Instructions

The oil pump gear can be removed while removing the torque converter housing.

The oil pump is a non-serviceable assembly and should be returned for service.

The converter and converter housing must be removed before removing the oil pump gear.

Special Tools

Typical service mechanic tools are needed

To Remove

1. From the oil pump gear, remove the retaining nut. Use a screwdriver to keep the gear from moving.
2. Remove the oil pump drive gear.
3. Remove the two (2) pump mounting capscrews.
4. Use the two (2) capscrews previously removed and insert them into the pump to lift the pump.
5. Remove the oil pump.
6. Remove the oil pump O-ring.
7. Inspect the snap ring, remove if damaged.
8. Remove the O-ring in the torque converter housing oil pump bore.

How to Install the Oil Pump

Special Instructions

The oil pump gear can be installed during the torque converter housing installation.

When installing the oil pump, do not damage the O-rings and use grease.

Special Tools

Typical service mechanic tools are needed.

To Install

1. Lube and install the oil pump O-ring in the torque converter housing oil pump bore.
2. If previously removed, install a new snap ring.
3. Lube and install the oil pump O-ring.
4. Lube the oil pump bore.
5. Install the oil pump, tap with soft faced hammer if necessary.
6. Install the two (2) pump mounting capscrews. Tighten to 35-45 Lb_f·ft of torque.
7. Inside the torque converter housing, install the oil pump drive gear.
8. On the oil pump gear, install a new retaining nut. Use a screwdriver to keep the gear from moving. Tighten to 34-48 Lb_f·ft of torque.

Final Check

Make sure the retaining capscrews are properly torqued.



H/27-3

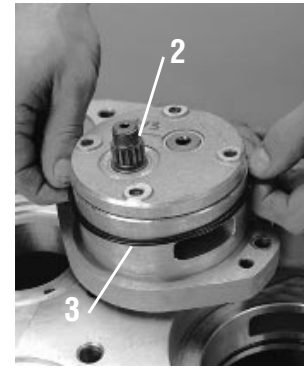

H/27-2

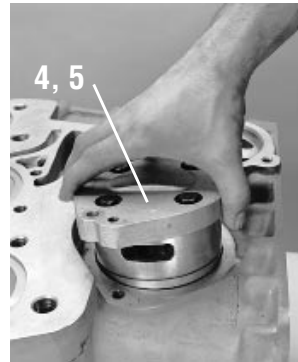

H/27-1

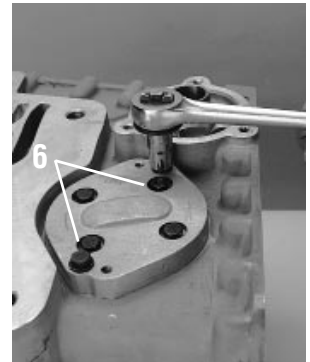

H/26-8



H/26-2



H/26-1

Torque Converter

How to Remove the Filter Bypass Valve

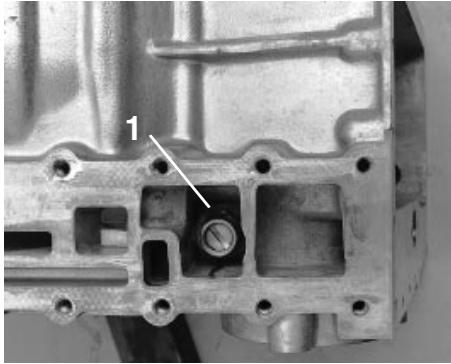

H/52-5

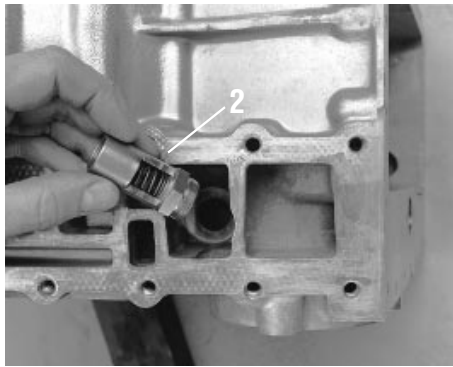

H/52-6

Special Instructions

The hydraulic valve must be removed.

Special Tools

Typical service mechanic tools are needed

To Remove

1. Use a hex socket to remove the filter bypass valve.
2. Inspect the valve for damage, replace if damaged.

How to Remove the HI Pressure Relief Valve

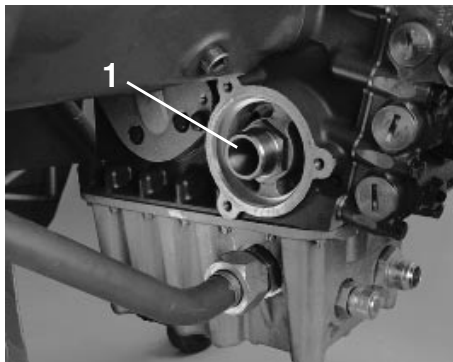

H/50-8

Special Instructions

The oil filter must be removed.

Special Tools

Typical service mechanic tools are needed

To Remove

1. Remove the oil filter adaptor.
2. Use a hex socket to remove the HI pressure relief valve.
3. Inspect the valve for damage, replace if damaged.

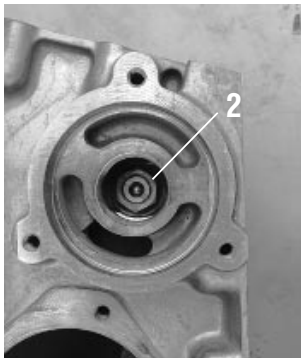

H/52-7



H/52-8

How to Install the Filter Bypass Valve

Special Instructions

The hydraulic valve must be removed.

Special Tools

Typical service mechanic tools are needed

To Install

1. Use a hex socket to install the filter bypass valve.
2. Tighten the valve to 26-32 Lb_f.ft of torque.

Final Check

Make sure the valve is properly torqued.

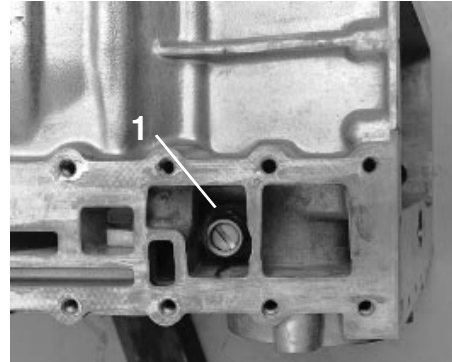

H/52-5

How to Install the HI Pressure Relief Valve

Special Instructions

The oil filter must be removed.

Special Tools

Typical service mechanic tools are needed

To Install

1. Use a hex socket to install the HI pressure relief valve.
2. Tighten the valve to 26-32 Lb_f.ft of torque.
3. Install the oil filter adaptor.

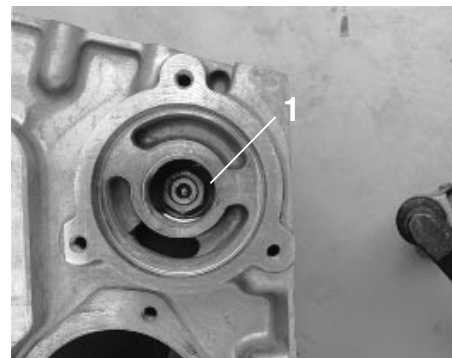

H/52-7

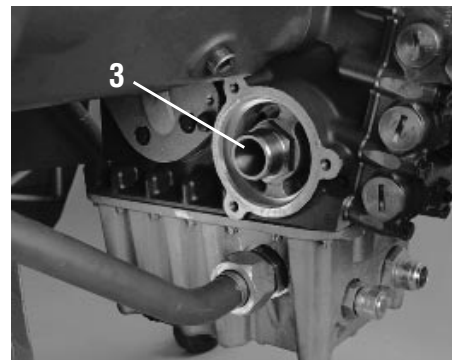

H/50-8

Transmission appearance may differ, procedure is the same.

Output Yoke/Companion Flange

How to Remove the Output Yoke/Companion Flange

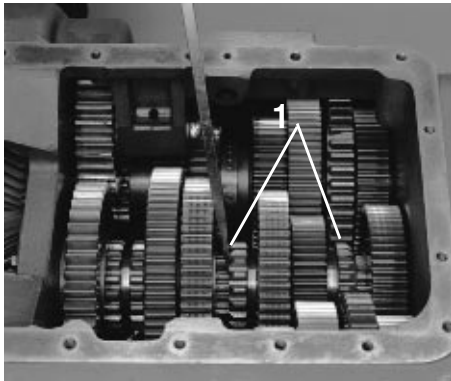

B/07-3

Special Instructions

If no impact or special tools are available, the shift bar housing must be removed in order to lock the transmission.

For proper cleaning and maintenance, see Form 193 "Rear Seal Maintenance Guide".

After removal of the output yoke/companion flange, temporarily replace the output shaft nut to protect the output shaft threads during auxiliary section disassembly.

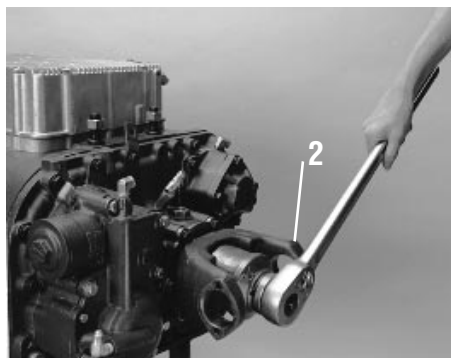

H/46-2

Special Tools

Typical service mechanic tools are needed

A large breaker bar or air impact wrench

To Remove

1. Engage two (2) mainshaft sliding clutches into two (2) mainshaft gears to lock the transmission.
2. Use a large breaker bar or air impact wrench to remove the output shaft nut.
3. Pull the yoke or flange straight to the rear and off the output shaft.

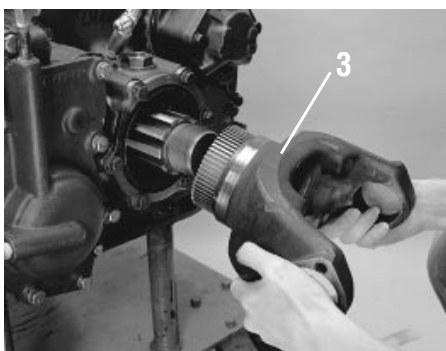

H/46-5

Output Yoke/Companion Flange

How to Install the Output Yoke/Companion Flange

Special Instructions

If no impact or special tools are available, the shift bar housing must be removed in order to lock the transmission.

For proper cleaning and maintenance, see Form 193 “Rear Seal Maintenance Guide”.

Special Tools

Typical service mechanic tools are needed
A torque wrench with 1000 Lb_f·ft capacity

To Install

1. Engage two (2) mainshaft sliding clutches into two (2) mainshaft gears to lock the transmission.
2. Install the speedometer drive gear rotor or replacement spacer on the output shaft inside the rear bearing cover.
3. If the slinger on the yoke is damaged, replace using a Slinger/Seal kit.
4. Slide the companion flange or yoke onto the output shaft.
5. Install the output shaft nut, tighten to 450-500 Lb_f·ft of torque.

Final Check

Make sure the output shaft nut is properly torqued.
Unlock the transmission.

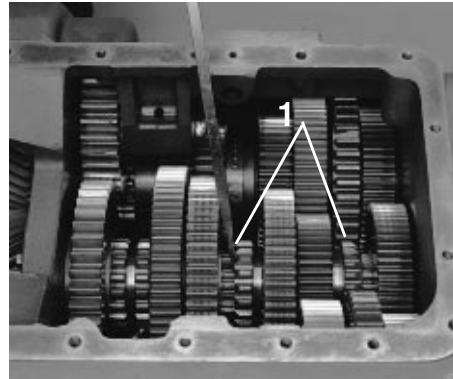

B/07-3

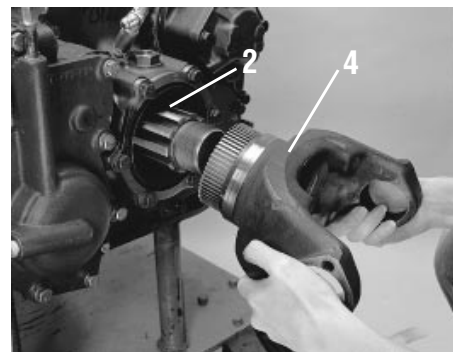

H/46-5

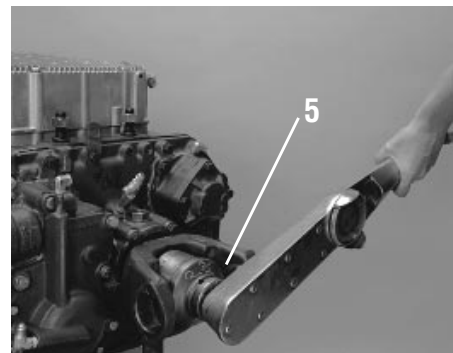

H/46-3

Auxiliary Section

How to Remove the Auxiliary Section

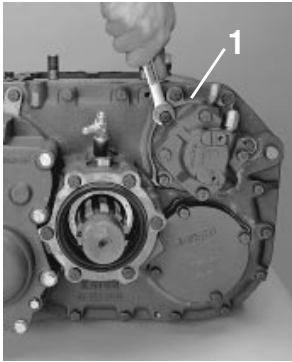

H/27-7

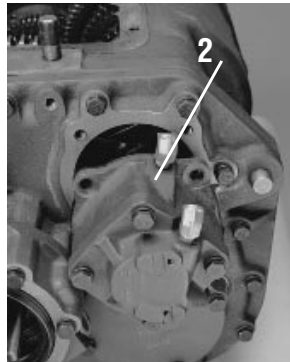

H/27-8

Special Instructions

There are different capscrew lengths, note their location. The auxiliary section should be removed with the transmission in the horizontal position.

The range cylinder housing must be loosened to remove the auxiliary section.

Special Tools

Typical service mechanic tools are needed

An auxiliary section hanger bracket for horizontal removal

A steel bar longer than the width of the output yoke for vertical removal

A hoist with a lifting chain

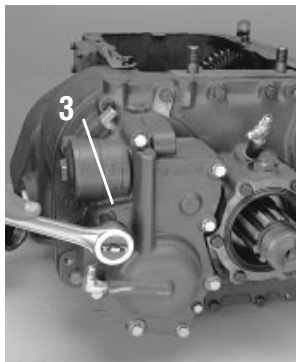

H/28-2

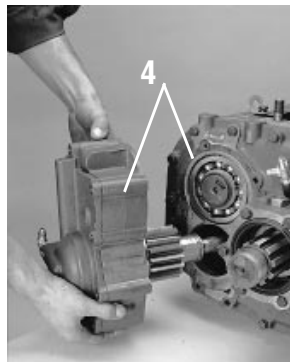

H/28-3

To remove the auxiliary section in the horizontal position.

1. Remove the four (4) capscrews in the range cylinder housing.
2. Move the range cylinder to the side and down.
3. From the power synchronizer, remove the mounting capscrews.
4. Remove the power synchronizer and gasket.
5. From the auxiliary section housing, remove the retaining capscrews that attach the front section to the auxiliary section.
6. From the auxiliary case, remove the two (2) allen head setscrews.
7. Insert the three (3) capscrews in the housing flange tapped holes. Tighten evenly to move the auxiliary section away from the front box. Go far enough to break the gasket seal.
8. Remove the capscrews from the tapped holes.
9. Attach an auxiliary section hanger bracket to the auxiliary section top.
10. Attach a lifting chain to the auxiliary section hanger bracket.
11. Move assembly to the rear until auxiliary section is free.
12. Remove the gasket and clean all mounting surfaces of gasket material.

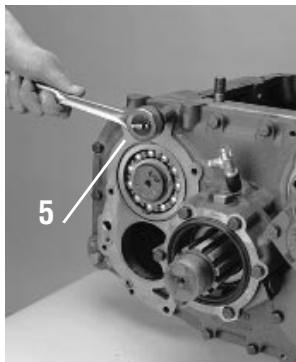

H/28-4

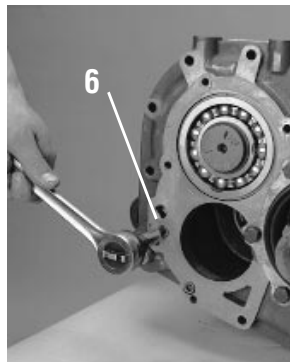

H/28-5

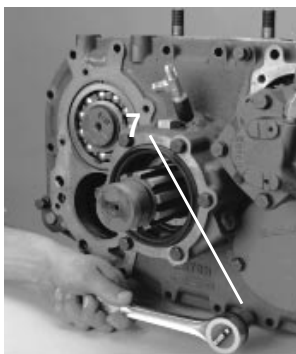

H/28-6

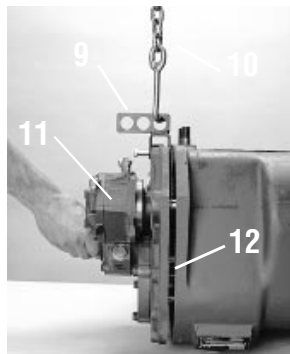

H/28-7

How to Install the Auxiliary Section

Special Instructions

There are different capscrew lengths, install in the correct location.

The auxiliary section should be installed with the transmission in the horizontal position.

Special Tools

Typical service mechanic tools are needed
An auxiliary section hanger bracket for horizontal removal
A steel bar longer than the width of the output yoke for vertical removal

A hoist with a lifting chain

To install the auxiliary section in the horizontal position.

1. Position a new gasket on the transmission mounting surface.
2. Attach an auxiliary section hanger bracket to the auxiliary section top.
3. Attach a lifting chain to the auxiliary section hanger bracket.
4. Position the auxiliary section on the two (2) dowel pins.
5. Slide the auxiliary section on until the hanger bracket contacts the front section back.
6. Remove the auxiliary section hanger bracket.
7. Install the two (2) allen setscrews. Tighten to 35-45 Lb_f·ft of torque.
8. Apply Eaton/Fuller Sealant #71205 or equivalent to the retaining capscrews.
9. Install the retaining capscrews, tighten to 35-45 Lb_f·ft of torque. On ATE models, tighten the short (1-1/2") to 26-32 Lb_f·ft of torque.
10. Position a new power synchronizer gasket and power synchronizer on the auxiliary case.
11. Install the mounting capscrews. Tighten to 35-45 Lb_f·ft of torque. The middle capscrew uses a washer.
12. Move the range cylinder up and forward. Install the range cylinder housing capscrews, tighten to 35-45 Lb_f·ft of torque.

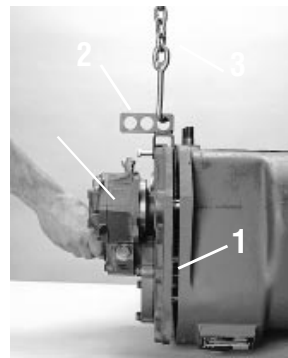

H/28-7

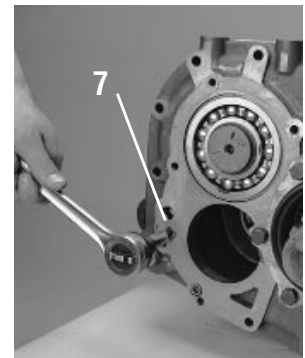

H/28-5

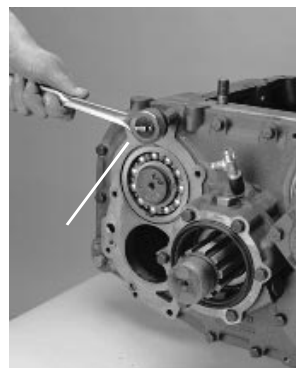

H/28-4

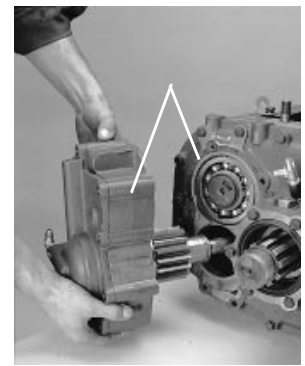

H/28-3

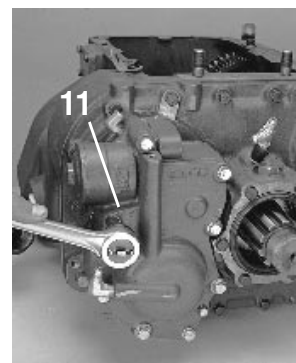

H/28-2

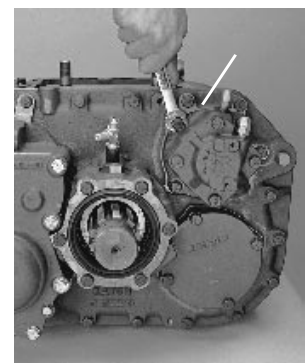

H/27-7

Auxiliary Section

How to Remove the Rear Bearing Cover Assembly

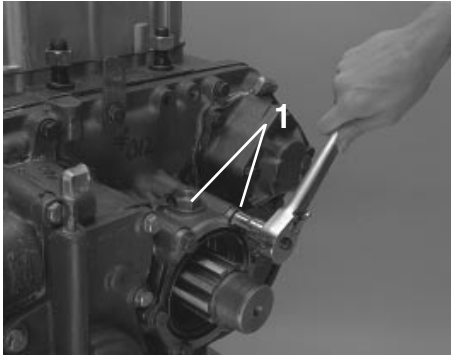

H/46-6

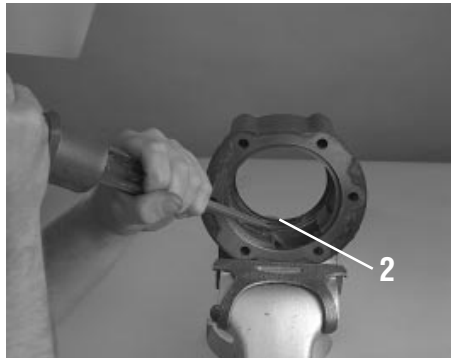

TA/08-7

Special Instructions

The rear bearing cover can be removed without disassembling the auxiliary section.

Special Tools

Typical service mechanic tools are needed

To Remove

1. Remove the retaining capscrews and the rear bearing cover and gasket.
2. Inspect the oil seal, remove if damaged.

How to Install the Rear Bearing Cover Assembly

Special Instructions

When installing the rear bearing oil seal, press into the rear bearing cover flush with the machined step. A thin coat of lubrication may be used on the seal O.D.

Because the collar becomes distorted when compressed, **do not re-use an old nylon collar** in the rear bearing cover.

Apply Eaton Lubricant #71214 or equivalent to speedometer plug O-rings, cover the entire surface. If the electronic sensor hole has a seal, apply lubricant #71214 or equivalent, covering the top surface. **Do not use an O-ring with the seal.**

Special Tools

Typical service mechanic tools are needed

Bearing driver and maul

Oil seal installation tool (K-2091)

To Install

1. If previously removed, install the oil seal in the rear bearing cover with the proper driver.
2. The seal should be installed so the spring is to the transmission front.
3. Position a new gasket on the rear bearing cover mounting surface and the rear bearing cover.
4. Apply Eaton/Fuller Sealant #71205 or equivalent to the retaining capscrews.
5. On AT/ATR/ATS models, use a new nylon collar and brass washer with the capscrew at the chamfered hole, the hole that intersects the speedometer bore.
6. Install the retaining capscrews, tighten to 35-45 Lb_f·ft of torque.

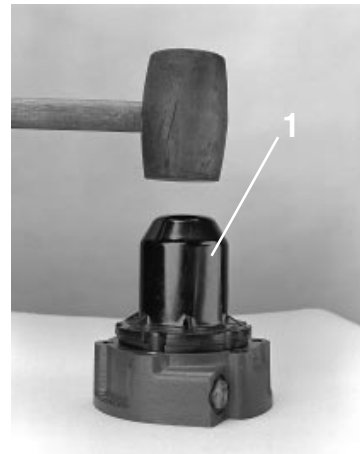

V/08-1



T/60-7

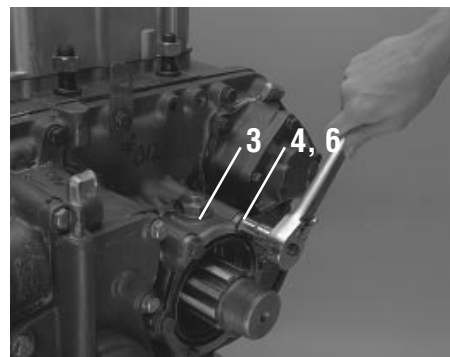

H/46-6

Final Check

Make sure the capscrews are properly torqued.



Section 5: Shift Bar Housing

Functions of a Shift Bar Housing

3

Shift Bar Housing

How to Disassemble the Shift Bar Housing

4

How to Assemble the Shift Bar Housing

6

Functions of a Shift Bar Housing

Shift bar housings are a very important part of the transmission. No matter what kind of shift bar housing your transmission has, they all provide the same functions:

- √ Engage the transmission gearing,
- √ Prevents the driver from shifting into 2 gears at the same time.

Shift Bar Housing

How to Disassemble the Shift Bar Housing

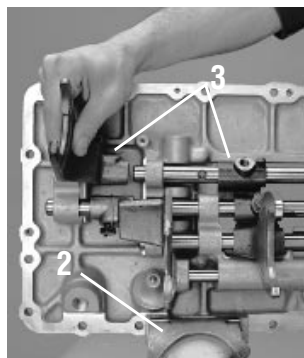

H/13-2

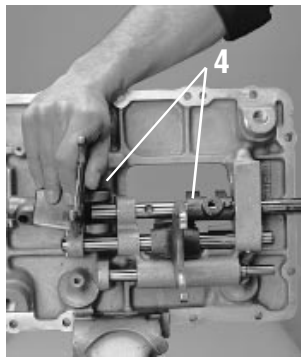

H/13-6

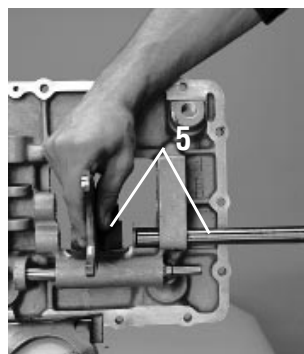

H/14-2

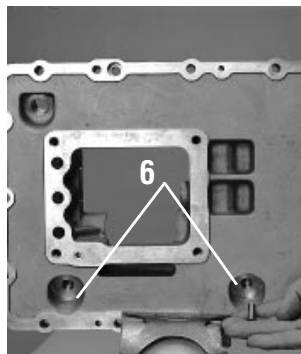

H/14-4

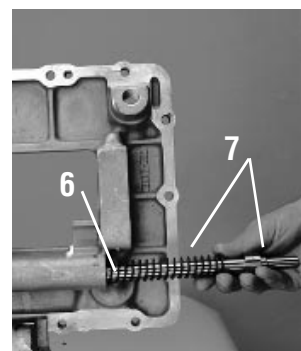

H/14-6

Special Instructions

The shift bar housing must be removed from the transmission.

During disassembly, lay all parts on a clean bench in order of removal to facilitate assembly.

Shift bars not being removed must be kept in the neutral position or the interlocking parts lock the bars.

Start with the top shift bar.

Cut the lockwire and remove the lockscrews from each bar just before their removal.

Use **caution** when removing the range sensor bar, it is under spring tension.

Special Tools

Typical service mechanic tools needed

Vise with brass jaws or wood blocks

To Disassemble

1. If the three (3) sets of tension springs and balls from housing bores have not been removed, place the shift bar housing on its side to remove them.
2. With the housing rear to the right, place the assembly in a vise.
3. While removing the top yoke bar to the right, remove the shift yoke and shift block.
4. From the second yoke bar, remove the shift yoke and shift block.
5. From the third yoke bar, remove the shift yoke.
6. Place your hand over the range sensor bar opening on the shift bar housing backside. From the housing front, remove the range sensor pins.
7. Carefully remove your hand in order to remove the range sensor bar and spring.
8. Inspect the yoke and block parts, replace the worn parts.

Shift Bar Housing

How to Assemble the Shift Bar Housing

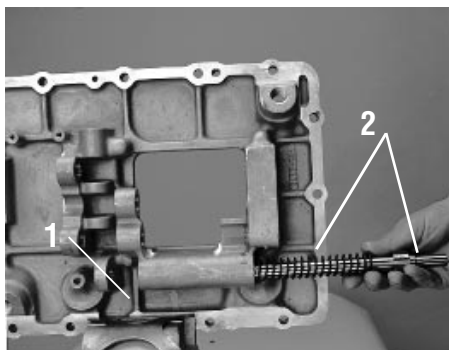

H/14-6

Special Instructions

Inspect shift blocks and shift yokes for wear.

Apply Eaton lockwire #1819 or equivalent to all shift bar housing assembly set screws in both blocks and yokes. The wire should anchor the capscrew at least 2 complete 360° turns. The lockwire ends should be trimmed and bent out of the way of any part interference.

Keep yoke bars in neutral while assembling.
Start with the bottom yoke bar.

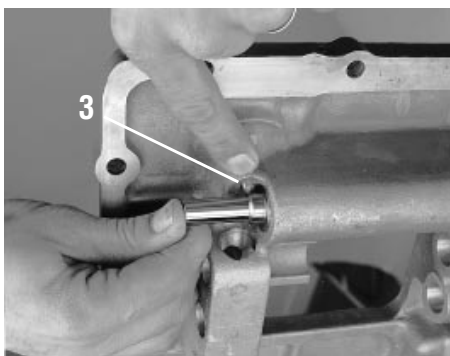

H/14-7

Special Tools

Typical service mechanic tools needed

Vise with brass jaws or wood blocks

To Reassemble

1. With the housing rear to the right, place the assembly in a vise.
2. Assemble the spring and range sensor bar. Install the range sensor bar.
3. Install the longer (about 1") range sensor pin. Make sure the pin are all the way in against the range sensor bar.
4. Install the shorter (about 3/4") range sensor pin.
5. Start installation of the second shift bar, as the bar passes the rear boss, position the shift yoke. Finish installation.
6. Install the shift yoke lock screw. Tighten to 35-45 Lb_f-ft of torque. Lockwire securely.

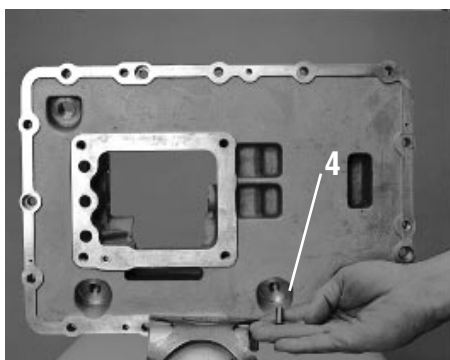

H/14-4

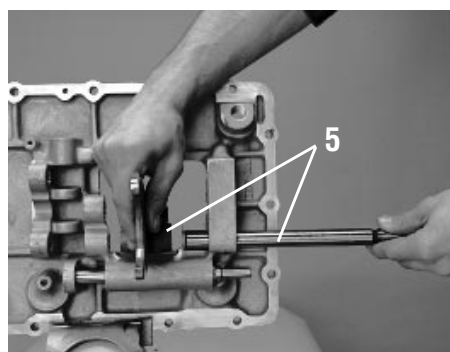

H/14-2

Shift Bar Housing

continued

How to Assemble the Shift Bar Housing

7. Holding the third bar notched-end, start installation. As the bar passes the rear boss, position the shift block.
8. As the bar passes the center boss, position the shift yoke on bar, long hub to the housing front.
9. Install the shift block and shift yoke lockscrews. Tighten to 35-45 Lb_f·ft of torque. Lockwire securely.
10. Holding the top bar notched-end, start installation. As the bar passes the rear boss, position the shift block.
11. As the bar passes the center boss, position the shift yoke on bar, long hub to the housing rear.
12. Install the shift block and shift yoke lockscrews. Tighten to 35-45 Lb_f·ft of torque. Lockwire securely.
13. Install the three (3) tension balls, one in each housing top bore. Install the three (3) detent springs, one over each tension ball.

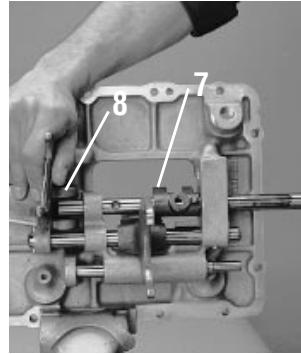

H/13-6

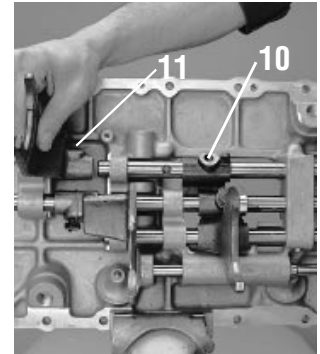

H/13-2

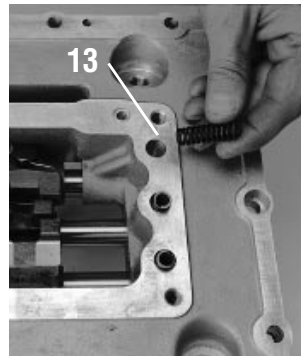

H/12-6

Final Check

Make sure interlocking system is working – can't shift into 2 gears at the same time.

Make sure all lockscrews are lockwired.



Section 6: Front Section

How to Disassemble the Front Section 2

How to Assemble the Front Section 3

Auxiliary Drive Gear Assembly

How to Remove the Auxiliary Drive Gear Assembly 4

How to Install the Auxiliary Drive Gear Assembly 5

How To Disassemble the Auxiliary Drive Gear Assembly 6

How To Assemble the Auxiliary Drive Gear Assembly 7

Reverse Idler Gear Assembly

How to Remove the Reverse Idler Gear Assembly 8

How to Install the Reverse Idler Gear Assembly 9

Countershaft Assembly

How to Remove the Countershaft Bearings 10

How to Install the Countershaft Bearings 11

How to Remove the Countershaft Assemblies 12

How to Install the Countershaft Assemblies 13

How to Disassemble the Countershaft Assembly 14

How to Assemble the Countershaft Assembly 15

Mainshaft Assembly

How to Remove the Mainshaft Assembly 16

How to Install the Mainshaft Assembly 17

How to Disassemble the Mainshaft Assembly 18

How to Assemble the Mainshaft Assembly 19

Input Shaft Assembly

How to Remove the Input Shaft Assembly 24

How to Install the Input Shaft Assembly 25

How to Disassemble the Front Section

Follow the solid line,
then the dash/dot line,
then the dashed line

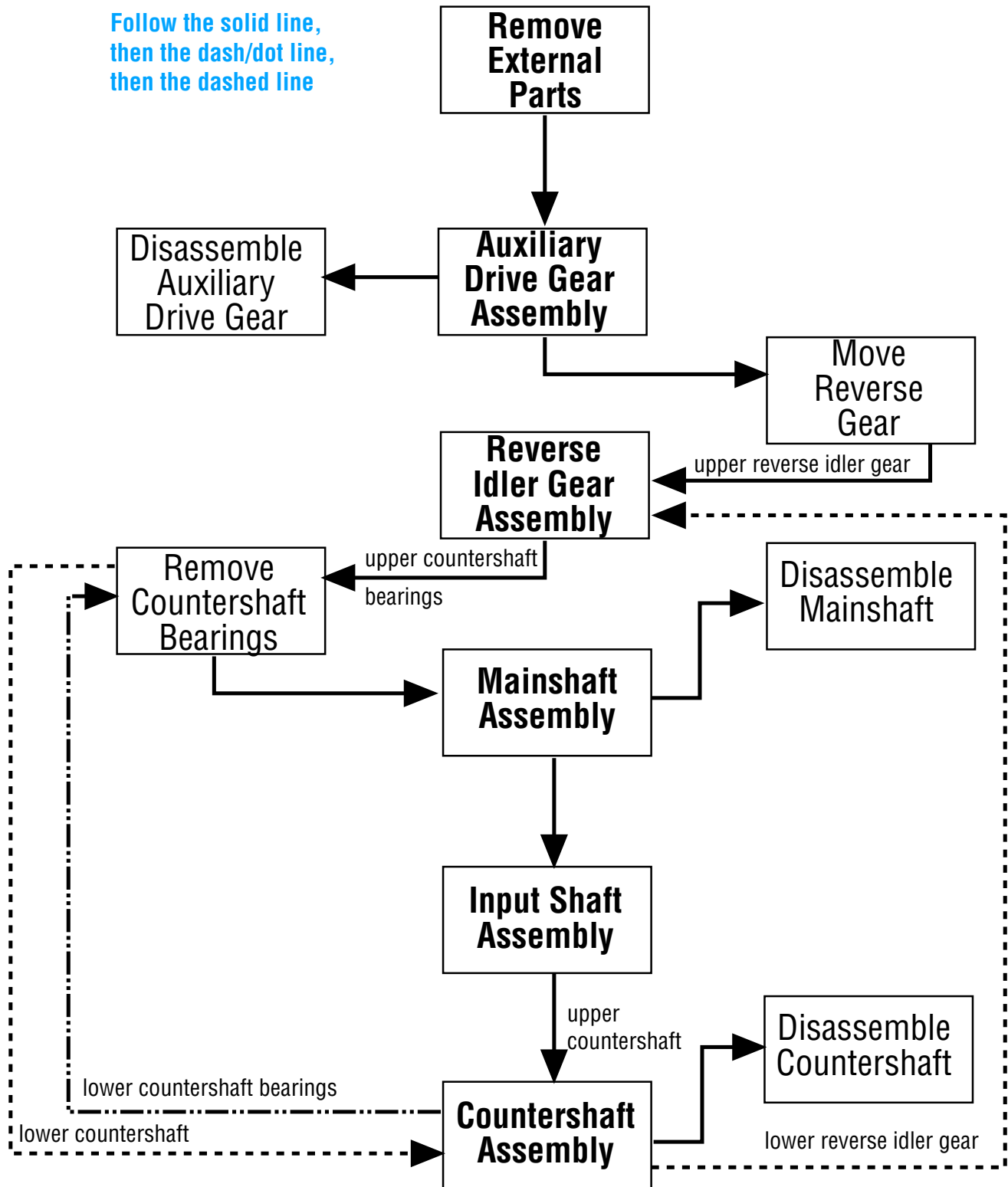

DS/FS-1



How to Assemble the Front Section

Follow the solid line,
then the dash/dot line,
then the dashed line

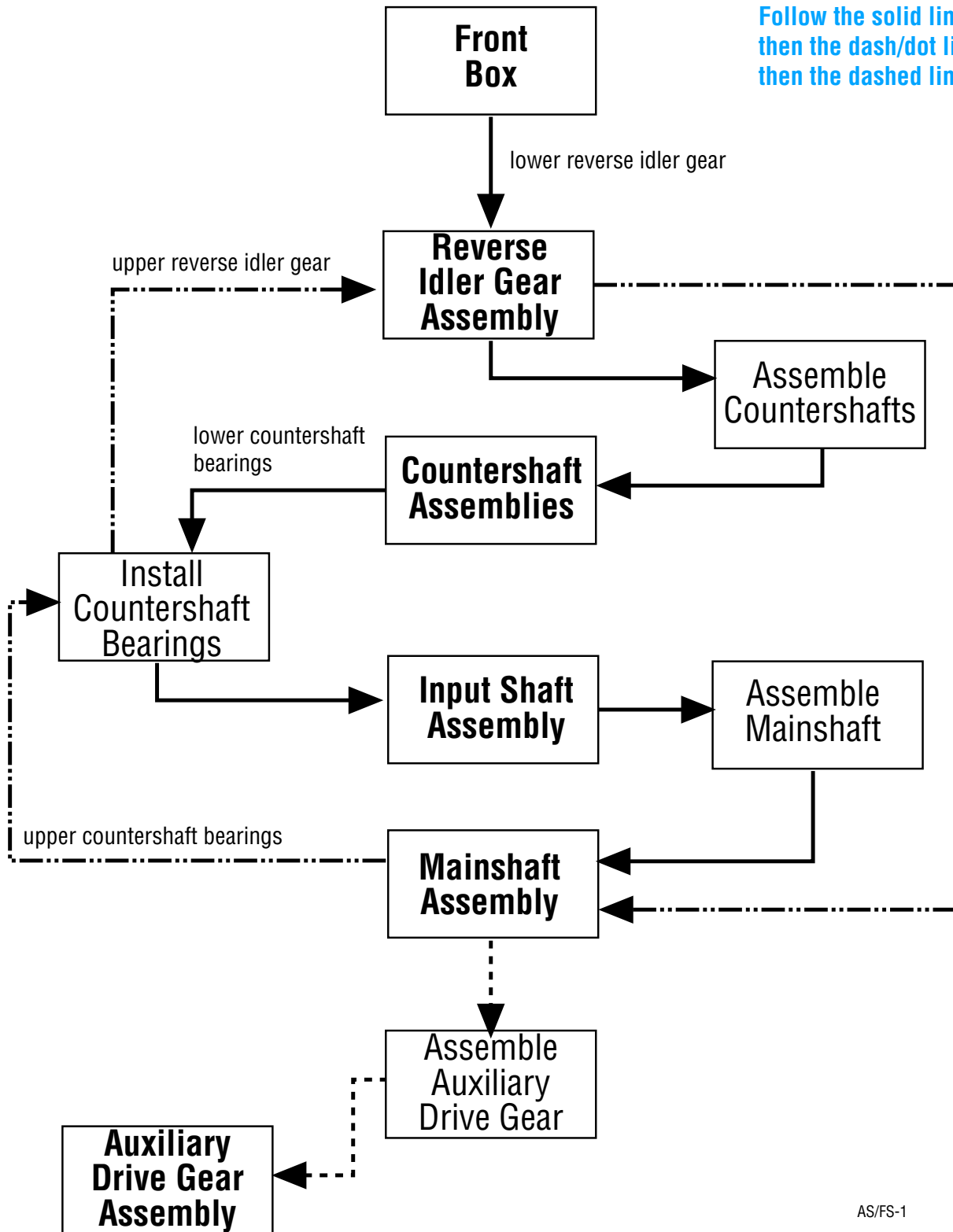

AS/FS-1

Auxiliary Drive Gear Assembly

How to Remove the Auxiliary Drive Gear Assembly

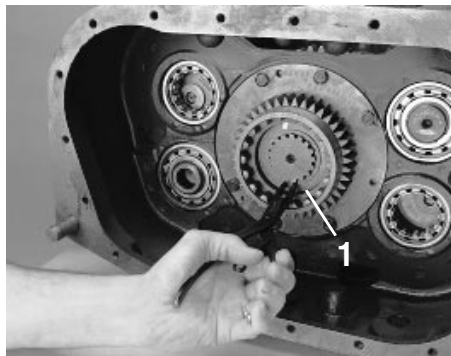

H/32-1

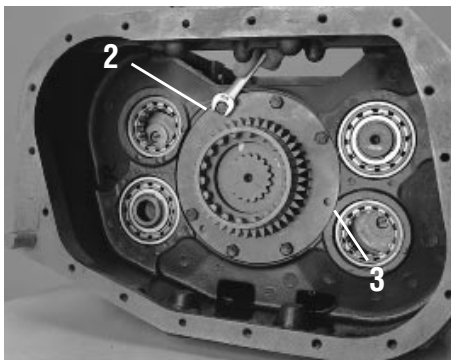

H/32-3

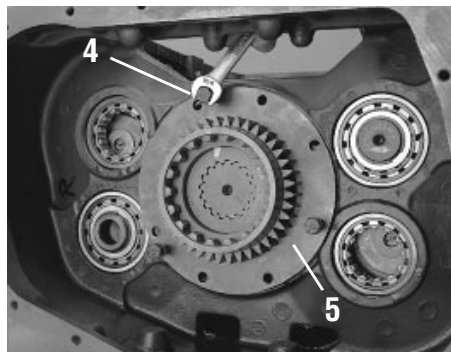

H/32-4

Special Instructions

Before removing the auxiliary drive gear, the auxiliary section must be removed.

Special Tools

Typical service tools are needed
Large pair of snap ring pliers

To Remove

1. Remove the mainshaft rear groove snap ring.
2. Remove the auxiliary bearing retainer ring capscrews.
3. Insert three (3) of the capscrews in the specially tapped holes of the retainer ring.
4. Tighten the capscrews evenly to force the auxiliary drive gear assembly from the case.
5. Remove the auxiliary drive gear from the mainshaft.

Auxiliary Drive Gear Assembly

How to Install the Auxiliary Drive Gear Assembly

Special Instructions

Before installing the auxiliary drive gear, the mainshaft must be completely installed.

Special Tools

Typical service tools are needed

Large pair of snap ring pliers

Flanged-end driver and maul

To Install

1. Position the auxiliary drive gear assembly on the mainshaft.
2. Use a flanged-end driver and maul to seat the auxiliary drive gear bearing.
3. Align the retainer ring capscrew holes with the tapped holes.
4. Apply Eaton/Fuller sealant #71205 or equivalent to the retaining capscrews.
5. Install the retaining capscrews, tighten to 23-30 Lb_f·ft of torque.
6. Install the auxiliary drive gear retaining snap ring in the mainshaft snap ring groove.

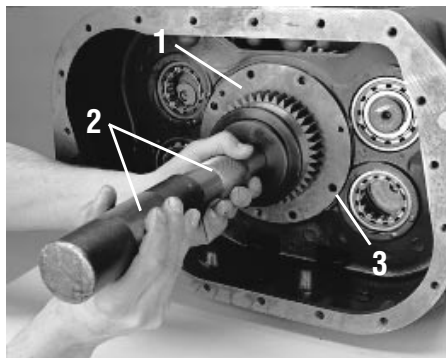

H/36-3

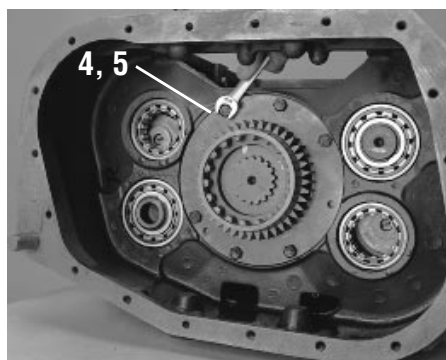

H/32-3

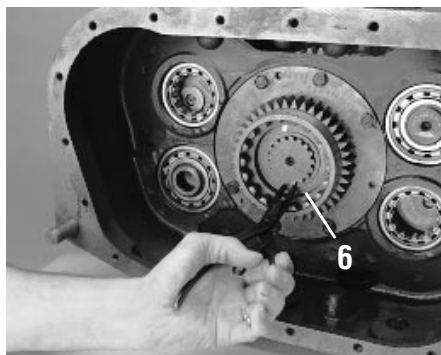

H/32-1

Auxiliary Drive Gear Assembly

How To Disassemble the Auxiliary Drive Gear Assembly

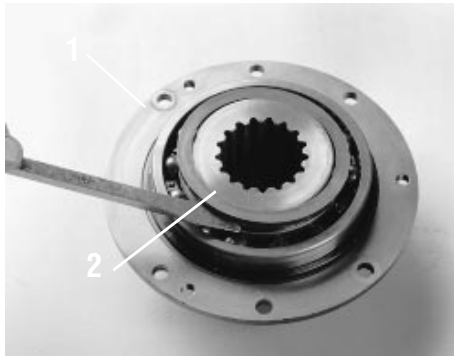

B/20-4



B/20-5

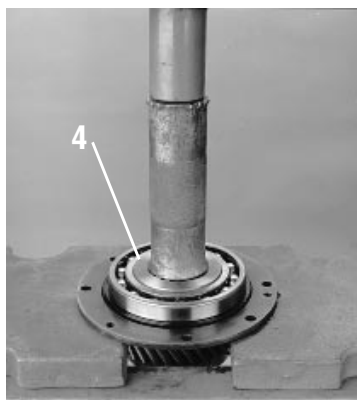

U/15-4

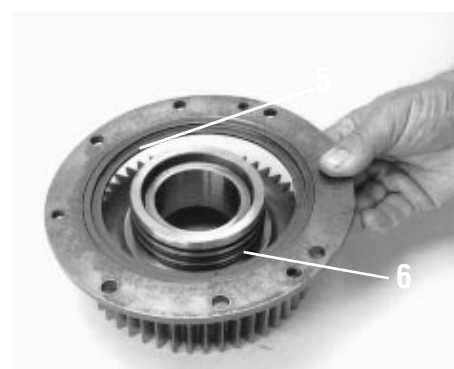

A/20-8

Special Instructions

To disassemble, the auxiliary drive gear must be removed.

Special Tools

Typical service tools are needed
A large pair of snap ring pliers

To Disassemble

1. Lay the front auxiliary drive gear on a clean, flat surface.
2. From the front auxiliary drive gear hub, use a screwdriver to pry off the snap ring retainer.
3. From the front auxiliary drive gear hub, remove the snap ring.
4. Use the front hub as a base and press the drive gear through the bearing.
5. Remove the retaining ring.
6. Inspect the drive gear O-rings, remove is cracked or distorted.

Auxiliary Drive Gear Assembly

How To Assemble the Auxiliary Drive Gear Assembly

Special Instructions

Apply Eaton Lubricant #71214 or equivalent to the auxiliary drive gear O-rings.

Special Tools

Typical service tools are needed

To Assemble

1. If the O-rings were removed, apply lube and install on the drive gear.
2. Lay the front auxiliary drive gear on a clean, flat surface.
3. With snap ring groove away from gear teeth, install the retaining ring on the front auxiliary drive gear.
4. With bearing snap ring facing groove in bearing ring, start the bearing on hub. Press into position until fully seated.
5. To retain the bearing, install the snap ring in front gear hub groove.
6. With grooved side down, use a flanged-end driver and install the outer retainer ring.

Final Check

Make sure the outer retainer ring is seated.

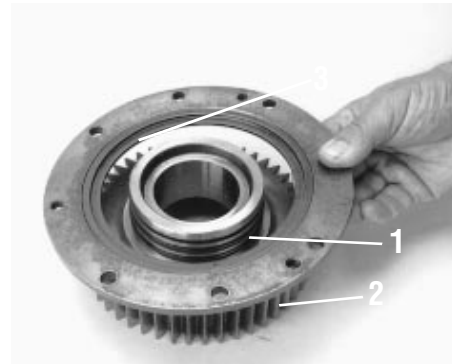

A/20-8

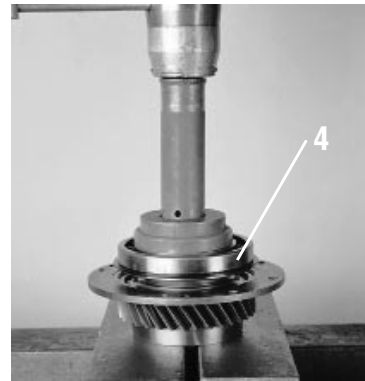

B/20-7

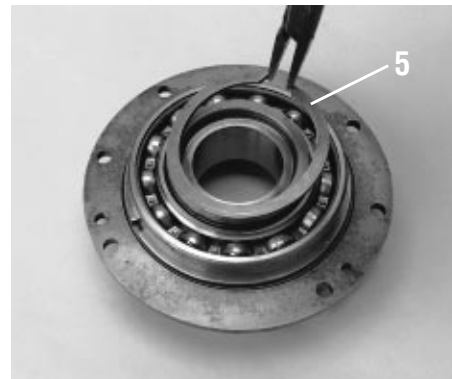

A/20-4



B/20-8

Transmission appearance may differ, procedure is the same.

Reverse Idler Gear Assembly

How to Remove the Reverse Idler Gear Assembly

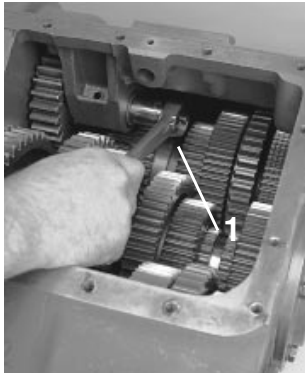

O/10-2

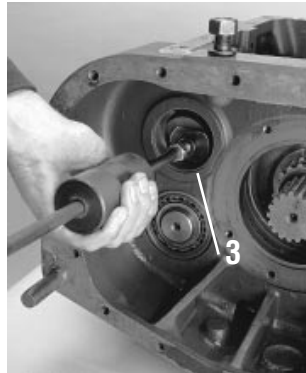

O/10-6



O/10-4

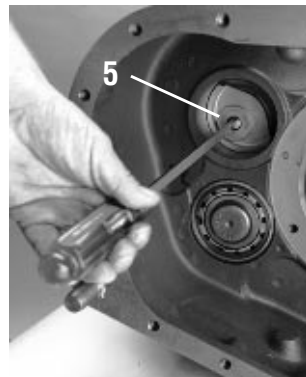

A/26-1

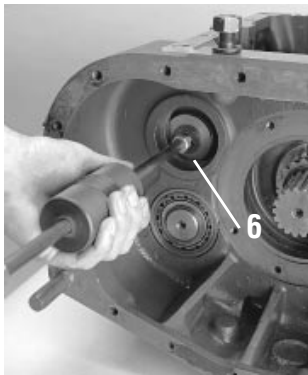

O/10-7

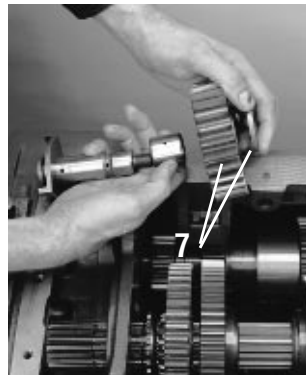

A/03b-1



B/21-5

Special Instructions

The following instructions are used to remove upper and lower reverse idler gears.

Before the upper reverse idler gear assembly can be removed, mainshaft reverse gear must be positioned forward against the next gear.

While removing the reverse idler shaft, the thrust washer can drop to the transmission case bottom.

The mainshaft reverse gear must be moved in order to remove the upper reverse idler gear, see "How to Remove the Mainshaft Assembly", steps 1-3.

Special Tools

Typical service tools are needed

Jaw Pullers or Impact Puller

To Remove

1. From the idler shaft inside the case, loosen the lock nut and washer.
2. The mainshaft reverse gear must be moved in order to remove the upper reverse idler gear, see "How to Remove the Mainshaft Assembly", steps 1-3.
3. From the reverse idler gear bore, use an impact puller to remove the auxiliary countershaft front bearing race.
4. Remove the loosened lock nut and washer.
5. From the idler shaft rear, remove the pipe plug.
6. Install an impact puller, 1/2"-13 threaded end, and remove the shaft from case bore.
7. As the idler shaft and idler plate are removed, remove the thrust washer and gear.
8. Inspect the reverse gear assembly, remove the inner race and press the needle bearing from the idler gear, if damaged.

Reverse Idler Gear Assembly

How to Install the Reverse Idler Gear Assembly

Special Instructions

If you are installing the bottom reverse idler gear assembly, make sure the three (3) magnetic discs are securely in place at case bottom. Use Eaton Adhesive #71210 or equivalent.

Special Tools

Typical service tools are needed

To Install

1. If reverse gear assembly is disassembled, press the needle bearing and position the inner race into the reverse idler gear.
2. Install the idler plate on the shaft, flat side to the front
3. Insert the idler shaft into the case bore, threaded-end to the front. As the shaft passes through the case bore position the reverse idler gear on the shaft, long hub to the front and seated on the bearing inner race. Insert the thrust washer between the reverse idler gear and the case support boss. Finish inserting the idler shaft.
4. Make sure the reverse idler shaft is seated in the support boss bore and as forward as far as possible.
5. Install the washer and lock nut on shaft front. Tighten the stop nut to 50-60 Lb_f.ft of torque.
6. Thread the pipe plug into the reverse idler shaft and tighten to 6-8 Lb_f.ft of torque.
7. Use a bearing driver and maul and install the auxiliary countershaft front bearing outer race against the idler plate.

Final Check

Make sure the stop nut is properly torqued.

Make sure the bearing outer race is installed against the idler plate.



B/21-5



B/21-6

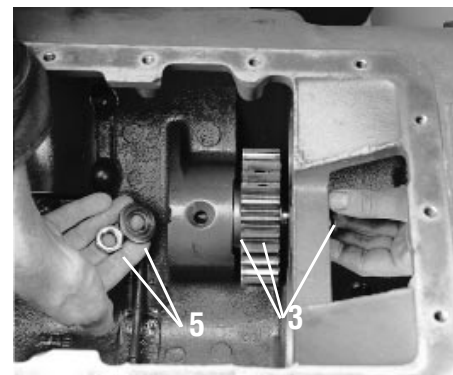

B/21-2

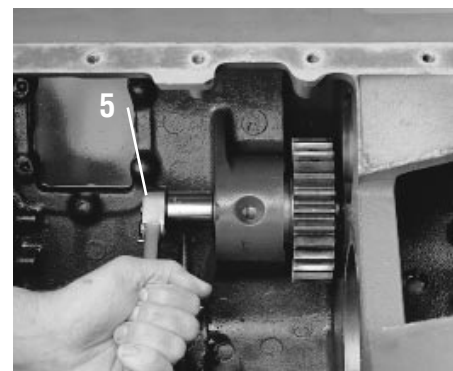

B/20-9

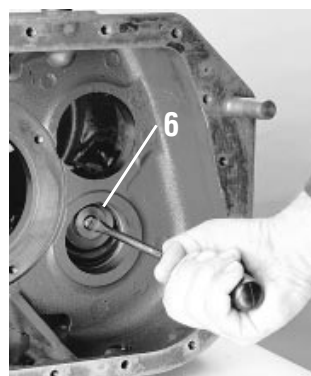

B/21-3

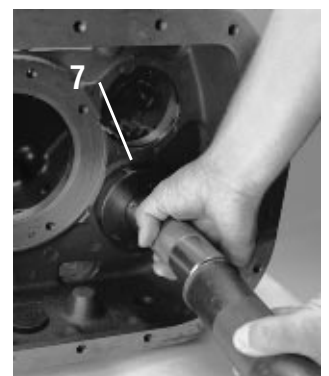

A/17-2

Transmission appearance may differ, procedure is the same.

Countershaft Assembly

How to Remove the Countershaft Bearings

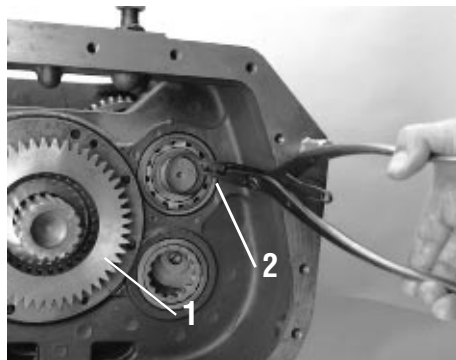

A/25-7

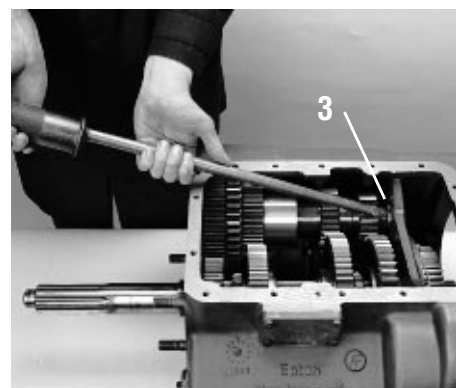

A/02b-2

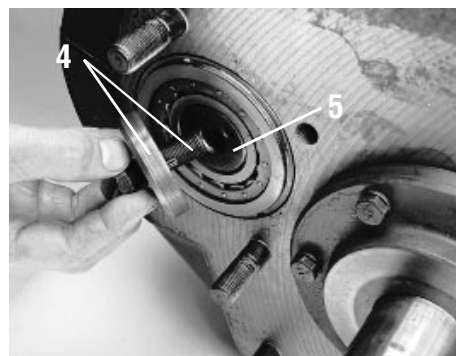

A/05b-4

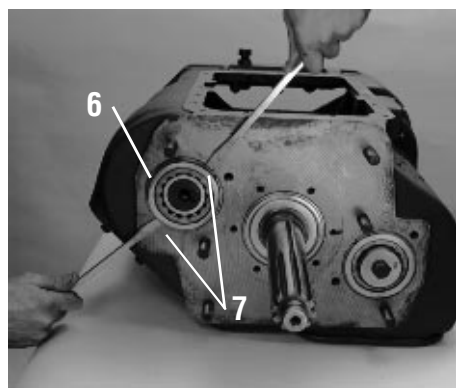

A/02b-3

Special Instructions

The following instructions are used to remove the upper and lower countershaft bearings. To remove the mainshaft assembly, only the upper countershaft bearings need to be removed.

Performing the following instructions will damage the bearings and should not be done unless bearing replacement is planned.

The bearing inner race remains pressed on the countershaft after removal of the front bearings.

Special Tools

Typical service tools are needed

Soft bar and maul

Bearing puller or pry bars

To Remove

1. To keep the mainshaft pilot from falling out of the input shaft pocket, temporarily install the auxiliary drive gear on the mainshaft.
2. From each countershaft rear groove, remove the snap ring.
3. From inside the case, use a soft bar and maul to drive the countershaft rear bearings from the case bores.
4. From the each countershaft front, remove the cap screw and front retainer plate.
5. Use the soft bar and maul to drive each countershaft to the rear as far as possible. This partially unseats the front bearings.
6. Return to the case rear, and drive each countershaft forward as far as possible. This exposes the bearing snap rings.
7. Use a bearing puller or pry bars to remove the countershaft front bearings.

Countershaft Assembly

How to Install the Countershaft Bearings

Special Instructions

The front bearing inner race must be pressed on the countershaft front.

The flanged-end driver must cover the bearing outer race for proper installation.

Special Tools

Typical service tools are needed

Countershaft support tool

Flanged-end driver and maul

To Install

1. Move the countershaft to the rear and insert the countershaft support tool to center shaft in rear case bore.
2. Use a flanged-end driver to start the front bearing in case bore.
3. Use a screwdriver inserted in the countershaft capscrew bore to help center the countershaft.
4. Move the countershaft forward into the bearing.
5. Use a flanged-end bearing driver and maul to completely seat the front bearing in case bore.
6. On the countershaft front, position the retainer plate with roll pin in shaft end hole.
7. Secure with capscrew, tightening to 90-120 Lb_f·ft of torque.
8. From the rear, remove the countershaft support tool.
9. With the larger I.D. lead chamfer to the shaft front, use a flanged-end bearing driver and install the rear bearing.
10. In the countershaft rear groove, install the rear snap ring.

Final Check

Make sure each front bearing capscrew is properly torqued.

Make sure each rear snap ring is in place.

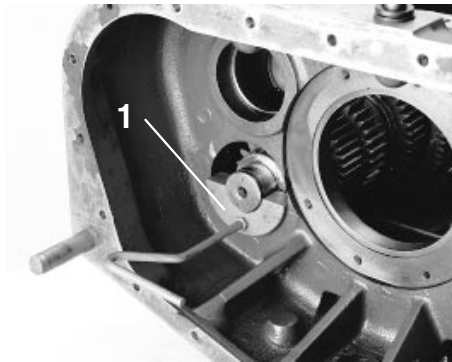

B/21-7



B/21-8

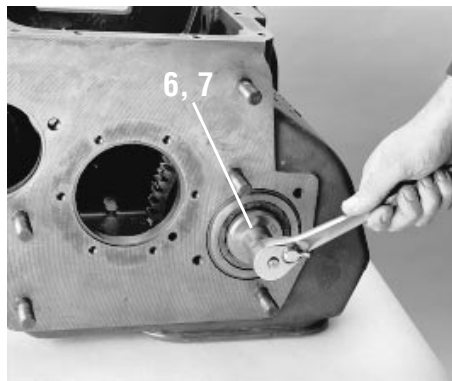

B/21-9



B/22-1

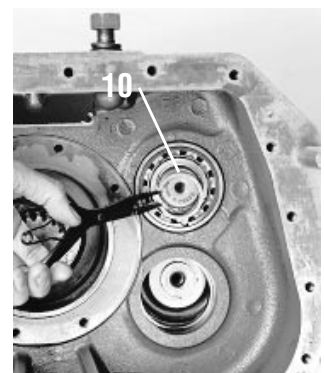

B/15-5

Transmission appearance may differ, procedure is the same.

Countershaft Assembly

How to Remove the Countershaft Assemblies



B/19-1

Special Instructions

Except for the PTO gears the upper and lower countershaft assemblies are the same. Make sure and mark each as they are removed.

Special Tools

Typical service tools are needed

To Remove

1. Move the upper countershaft assembly to the rear as far as possible.
2. Swing the countershaft front to middle of the case.
3. Lift the countershaft assembly from the case.

Countershaft Assembly

How to Install the Countershaft Assemblies

Special Instructions

Make sure the countershaft assemblies have been marked for proper position, 47-tooth PTO gear in the lower position.

On the drive gear of each countershaft assembly, mark the tooth aligned with the gear keyway and stamped with an “O” for easy identification. A highly visible color of toolmaker’s dye is recommended for making timing marks.

Special Tools

No service tools are needed

Toolmaker's dye

To Install

1. Mark the countershaft drive gear for timing purposes.
2. Place the lower, 47-tooth PTO gear countershaft assembly in the case, the drive gear to the front.
3. Position as far to the left as possible (the opposite side as the lower reverse idler gear assembly.)
4. Place the upper, 45-tooth PTO gear countershaft assembly in the case, the drive gear to the front.
5. Position as far to the right as possible (the same side as the lower reverse idler gear assembly).

Final Check

Make sure the upper and lower countershafts are in the right place.

Make sure the timing marks are visible.

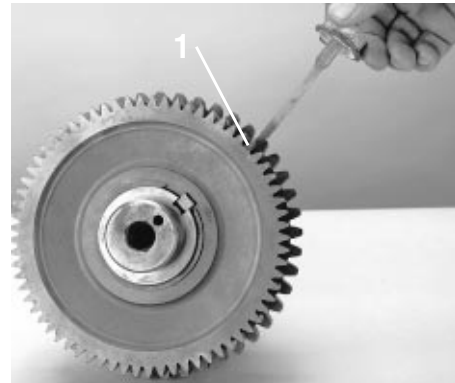

A/19-6

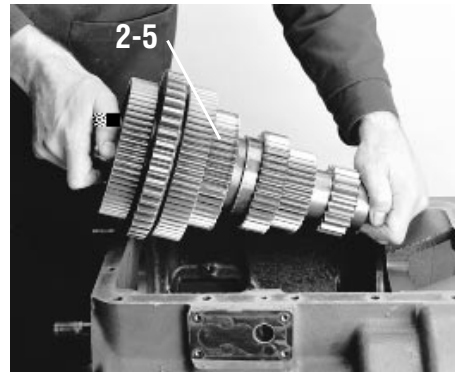

B/19-1

Countershaft Assembly

How to Disassemble the Countershaft Assembly



Special Instructions

Never use the PTO gear as a pressing base. The narrow width of this gear can cause breakage.

Special Tools

Snap ring pliers

Press

To Disassemble

1. From each countershaft front remove the drive gear retaining snap ring.
2. Using the rear face of 4th speed gear as a base, press the drive gear, PTO gear, and 4th speed gear from each countershaft. This removes the front bearing inner race.
3. Using the rear face of 2nd speed gear as a base, press 3rd speed gear and 2nd speed gear from each countershaft.
4. Inspect the keys and roll pin, remove if damaged.

B/19-2

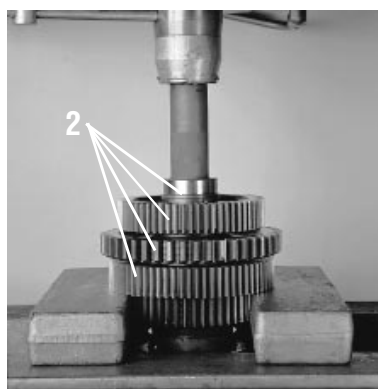

B/19-3

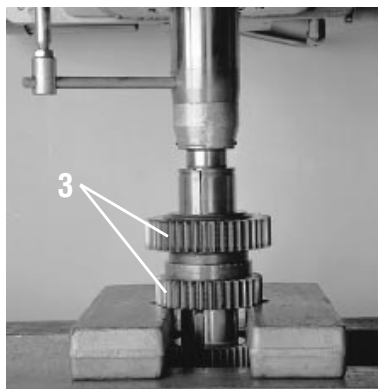

B/19-4



B/19-5

Countershaft Assembly

How to Assemble the Countershaft Assembly

Special Instructions

Except for the PTO gears, the upper and lower countershaft assemblies are the same. To avoid confusion during installation, mark the upper countershaft (45-tooth PTO gear) with an “U”. The lower countershaft has a 47-tooth PTO gear.

Special Tools

Snap ring pliers

Press

To Assemble

1. If previously removed, install the roll pin and keys in countershaft keyway.
2. Align 2nd speed gear keyway with the countershaft key, long hub to countershaft front, and press the gear on the countershaft.
3. Align 3rd speed gear keyway with the countershaft key, long hub against 2nd speed gear, and press the gear on the countershaft.
4. Align 4th speed gear keyway with the countershaft key, long hub to countershaft front, and press the gear on the countershaft.
5. Align PTO gear keyway with the countershaft key, bullet-nose of teeth facing up (shaft rear). Align drive gear keyway with the countershaft key, long hub against PTO gear, and press both gears on the countershaft.
6. On each countershaft front, install the drive gear retaining snap ring in groove.
7. Use a flanged-driver or the press to install the bearing inner race on the countershaft front against the drive gear.

Final Check

Make sure all gears are pressed into place.

Make sure the bearing inner race is installed.



B/19-6

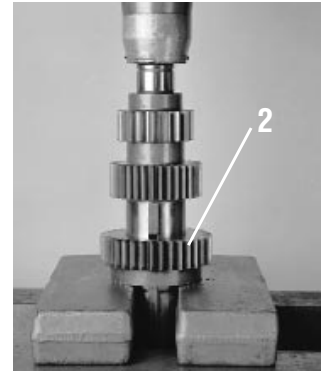

B/19-7

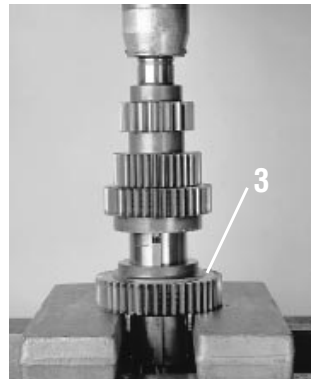

B/19-8

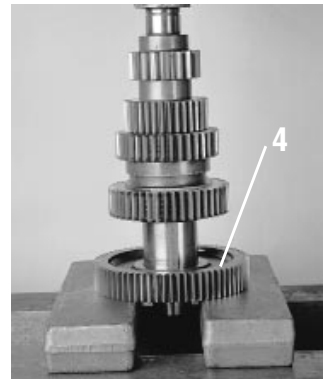

B/19-9

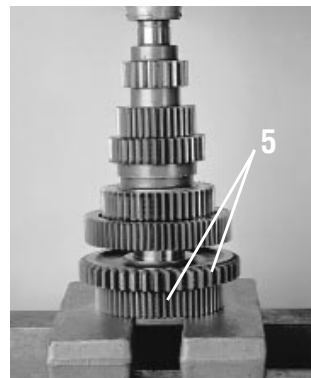

B/20-1



B/19-2



B/20-3

Transmission appearance may differ, procedure is the same.

Mainshaft Assembly

How to Remove the Mainshaft Assembly

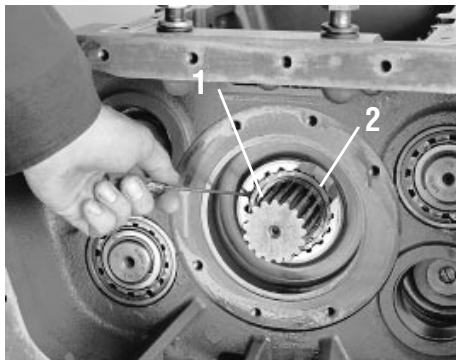

B/14-6

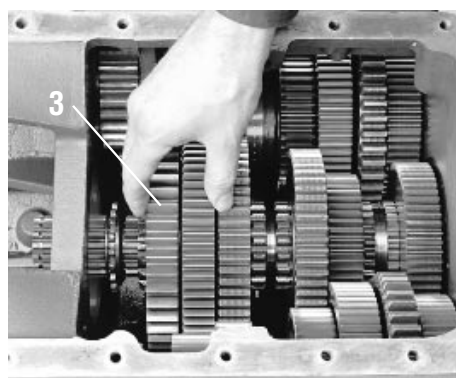

B/15-3

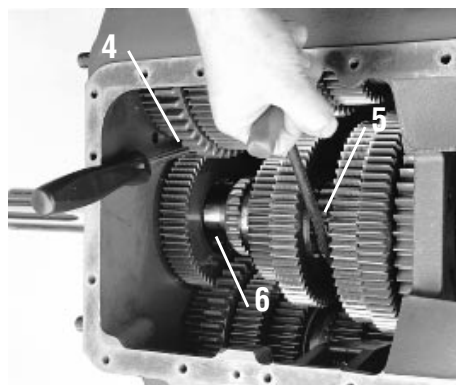

B/16-6

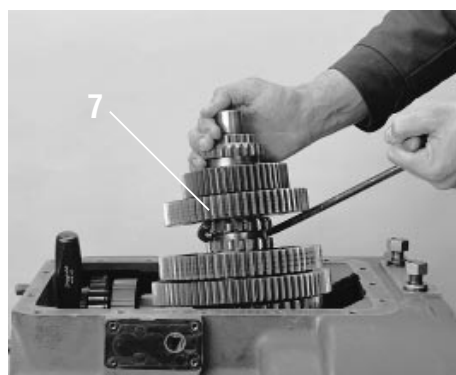

B/16-7

Special Instructions

Be careful when removing the mainshaft assembly, the sliding clutch on the end can slip off the mainshaft. Reverse gear is also free and can fall off the shaft.

Special Tools

Typical service tools are needed
Large hook or 3 foot piece of rope

To Remove

1. From the mainshaft, remove the reverse gear retaining snap ring.
2. Move the mainshaft reverse gear as far to the rear as possible and remove reverse gear I.D. snap ring.
3. Move the reverse gear forward and against the next gear, engaging the mainshaft sliding clutch spline.

If not removing the upper reverse idler gear assembly, you must remove the upper reverse idler gear assembly shaft and roll the gear to the outside, see “How to Remove the Reverse Idler Gear Assembly”, steps 1-4.

4. Use a large screwdriver and block the upper countershaft assembly against the case wall.

If removing the upper reverse idler gear assembly, see “How to Remove the Reverse Idler Gear Assembly” at this time.

5. Position the hook or rope around the mainshaft.
6. Pull the mainshaft to the rear to free the pilot from the input shaft pocket.

IMPORTANT: The upper countershaft must be kept forward against the case front wall. After the mainshaft is free of the pilot, move it as far forward as possible.

7. Tilt the mainshaft front up and lift assembly from the case.

Mainshaft Assembly

How to Install the Mainshaft Assembly

Special Instructions

The lower countershaft bearings and the input shaft must be installed.

Check to make sure the lower countershaft drive gear marked tooth is in time with main drive gear set of marked teeth.

Apply Eaton Lubricant #71215 or equivalent to the mainshaft pilot bushing, cover the entire surface.

Special Tools

Typical service tools needed

A large hook or 3' piece of rope

To Install

1. Block the upper countershaft forward and as close to the case wall as possible.
2. With reverse gear forward against the next speed gear, lower the mainshaft assembly while pulling the shaft rear through the case bore.
3. After the mainshaft drops into the case, slide the countershaft back and the mainshaft should fall down between the countershafts.
4. Move the mainshaft pilot-end into the input shaft pilot bushing. Mesh the mainshaft gears with the corresponding countershaft assembly gears.
5. Position the upper reverse idler gear in place, then roll the gear to the outside.
6. Mesh the reverse gear teeth with the reverse idler gear teeth and move the reverse gear to the rear as far as possible.
7. Align the reverse gear spacer external splines with the reverse gear and move the spacer into the reverse gear.
8. Install the reverse gear hub snap ring. Move the reverse gear forward on the mainshaft and into the proper case position.

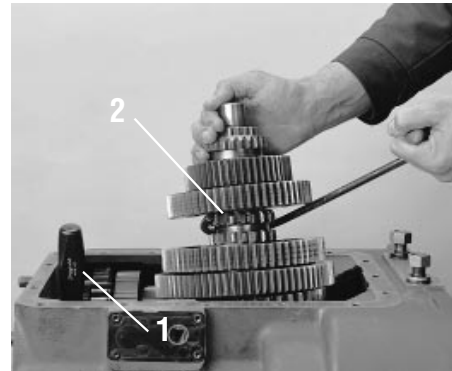

B/16-7

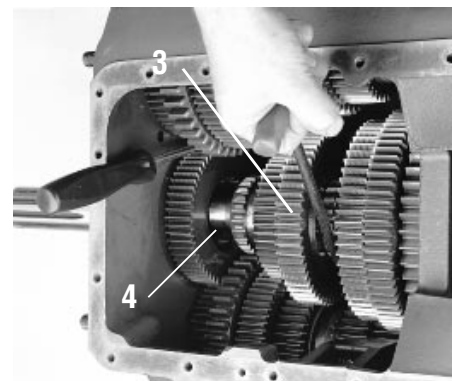

B/16-6

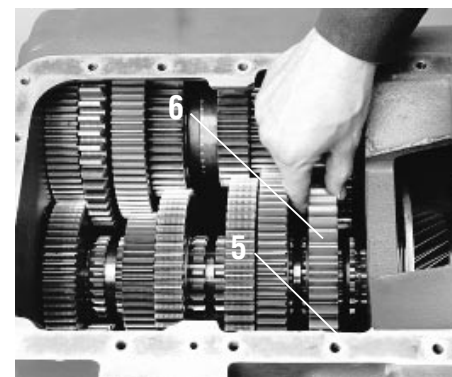

B/26-5



B/14-6

Transmission appearance may differ, procedure is the same.

Mainshaft Assembly

How to Disassemble the Mainshaft Assembly

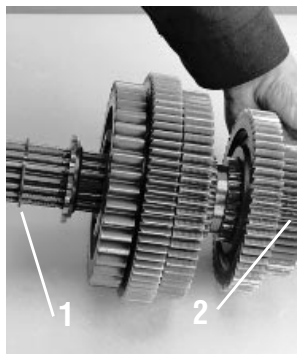

B/17-2

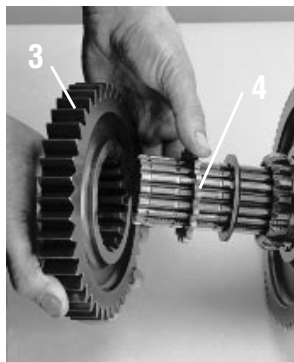

B/17-5



B/17-6



B/17-7



B/17-8



B/17-9

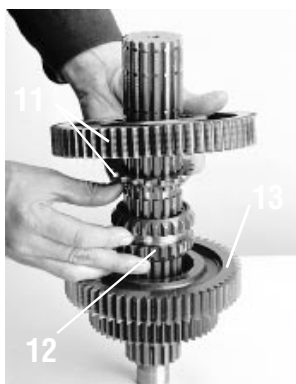

B/18-1

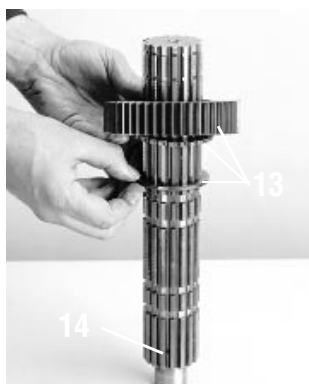

B/18-2

Special Instructions

During disassembly, lay all parts on a clean bench in order of removal to facilitate reassembly.

When removing limit washers, spacers and gears, note their location. Keep the internal-splined washers and external-splined spacers with the gear from which they were removed. There is only one limit washer and one spacer belonging to each gear.

Special Tools

Typical service tools are needed

To Disassemble

1. Remove the mainshaft key snap ring.
2. Tilt the mainshaft up, and from the opposite end, remove the sliding clutch.
3. Remove reverse gear.
4. Remove reverse gear spline spacer.
5. Place the mainshaft in a vertical position.
6. From the mainshaft rear, pull the mainshaft key from the mainshaft key way.
7. Turn the reverse gear limit washer to align its splines with the mainshaft and remove the washer.
8. Remove the reverse-1st speed sliding clutch.
9. Lift and turn 1st gear to align the limit washer splines.
10. Remove the limit washer, spacer and 1st gear.
11. Turn the 2nd gear limit washer to align its splines with the mainshaft. Remove 2nd gear and its limit washer.
12. Remove the 2nd-3rd sliding clutch
13. Remove each remaining gear, limit washer, and spacer.
14. Inspect the roll pin, remove if damaged.

Mainshaft Assembly

How to Assemble the Mainshaft Assembly

Special Instructions

Each mainshaft gear must have its I.D. snap ring installed before placement on the mainshaft. Do not replace reverse gear I.D. snap ring.

Gear limit washers are internally splined and locked to the mainshaft by the key. Gear spacers are externally splined to engage with gear hub clutching teeth. There is one limit washer and one spacer for each mainshaft gear. Use assembly grease on washers and spacers.

Axial clearance (end-play) limits are .006"-.015" for all mainshaft gears.

If the axial clearance is less than the minimum .006" tolerance, the limit washer should be replaced with a thinner limit washer. This will increase the axial clearance between the gears. If the axial clearance is greater than the maximum .015" tolerance, a thicker limit washer should be installed. This will decrease the axial clearance between the gears.

Special Tools

A vise with brass jaws or wood blocks

Feeler gauges

A piece of $\frac{5}{32}$ " air line, 2' long

To Assemble

1. With mainshaft pilot-end down, secure the mainshaft in a vise equipped with brass jaws or wood blocks.
2. If previously removed, install the roll pin in keyway.
3. With the washer flat side up, position the 4th speed gear limit washer (white) in the mainshaft 1st or bottom groove. Rotate the washer until the washer splines and mainshaft splines align.
4. Start at the mainshaft bottom and install a plastic line in the keyway to lock the washer in place. As limit washers and gears are installed, continue to push the plastic line up.

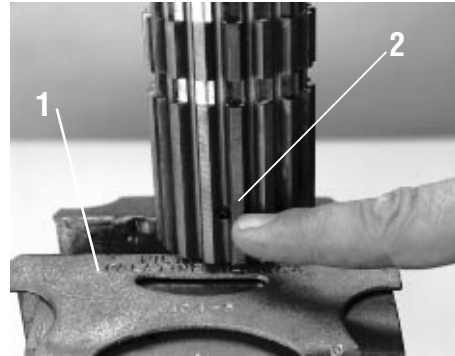

A/27-1

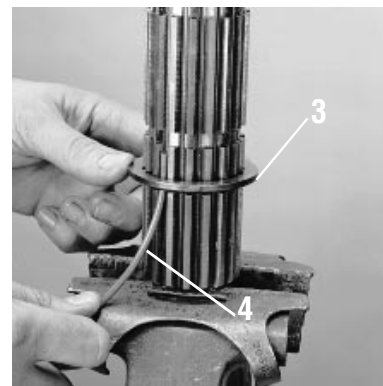

B/22-8

continued on next page

Mainshaft Assembly

continued

How to Assemble the Mainshaft Assembly

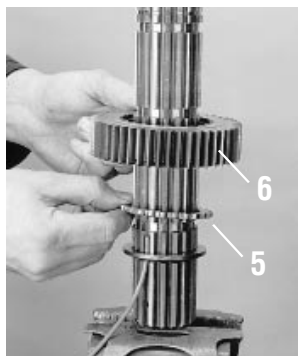

B/22-9



B/23-1

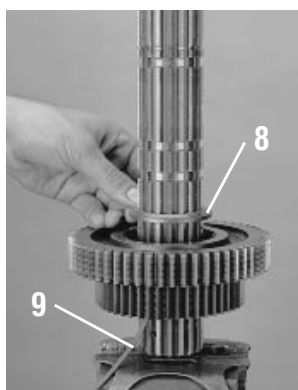

B/23-2

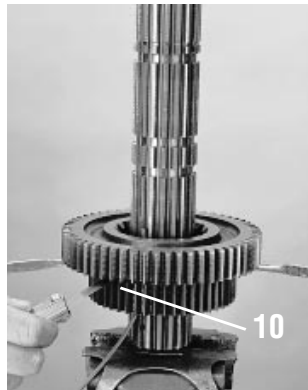

B/23-3

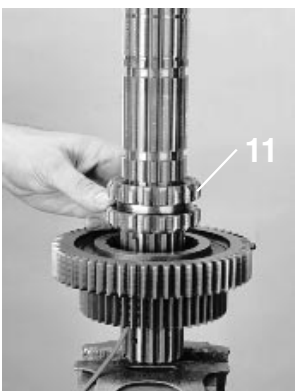

B/23-4

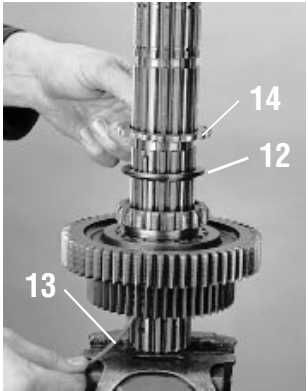

B/23-5

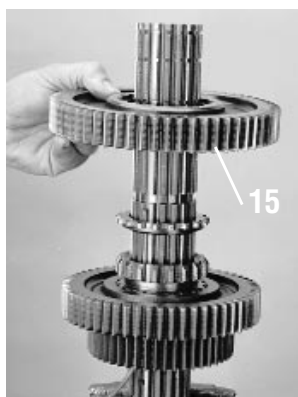

B/23-6



B/23-7

5. Against the 4th speed gear washer, position the 4th speed gear spacer.
6. With clutching teeth down and engaged with the spacer external splines, position the 4th speed gear on the mainshaft.
7. With clutching teeth up and against 4th speed gear, install the 3rd speed gear and spacer.
8. With the washer flat side down, position the limit washer against the spacer. Rotate the washer until the washer splines and mainshaft splines align.
9. Push the air line up to lock the washer on the mainshaft.
10. Between the gear hub and mainshaft spacer, insert .006" feeler gauge and .015" feeler gauge. If out of tolerance, change the limit against the mainshaft spacer. See "Special Instructions" for further information.
11. With the missing internal splines aligned with the plastic line, install the 2nd-3rd speed sliding clutch.
12. With the washer flat side up, position the 2nd speed gear limit washer (white) in the next available groove. Rotate the washer until the washer splines and mainshaft splines align.
13. Push the air line up to lock the washer on the mainshaft.
14. Install 2nd gear spacer.
15. With clutching teeth down, position the 2nd speed gear on the mainshaft engaging with spacer external splines.
16. With clutching teeth up, install 1st speed gear on shaft against 2nd speed gear.

continued

How to Assemble the Mainshaft Assembly

17. Position 1st speed gear spacer against 1st speed gear, engaging the spacer external splines with gear clutching teeth.
18. With washer flat side down, position the limit washer against the spacer. Rotate the washer until the washer splines and mainshaft splines align.
19. Push the air line up to lock the washer on the mainshaft.
20. Insert two large screwdrivers between 1st and 2nd speed gears and apply light pressure. Between the gear hub and mainshaft spacer, insert .006" feeler gauge and .015" feeler gauge. If out of tolerance, change the limit against the mainshaft spacer. See 'Special Instructions' for further information.
21. Align the sliding clutch missing internal spline with the mainshaft key and install the 1st-Reverse speed sliding clutch.
22. With the flat side up, position the Reverse speed gear limit washer (white) in the next available groove. Rotate the washer until the washer splines and mainshaft splines align.
23. Push the air line up to lock the washer on the mainshaft.
24. Against the limit washer, position reverse speed gear spacer.

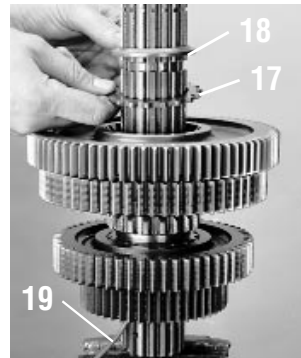

B/23-8

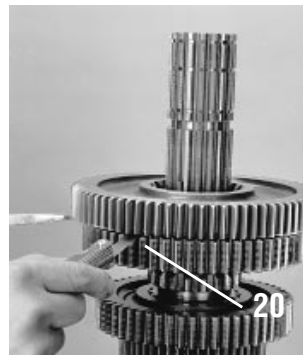

B/23-9



B/24-2

continued on next page

Mainshaft Assembly

continued

How to Assemble the Mainshaft Assembly

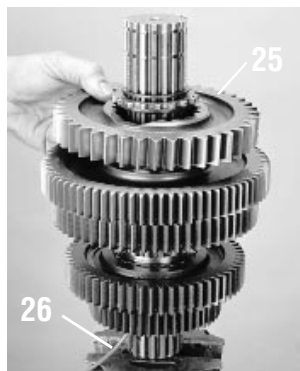

B/24-9



B/25-1

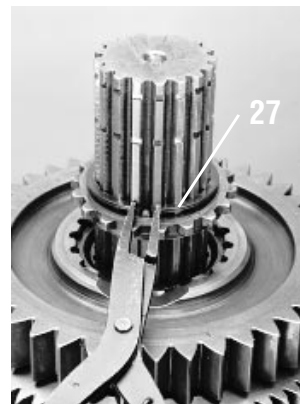

B/25-2

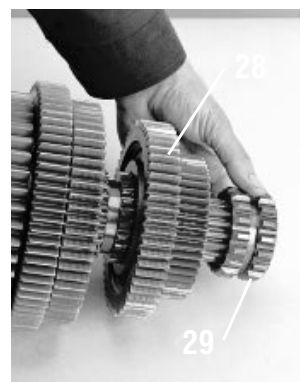

B/25-3

25. Remove the reverse gear snap ring from reverse gear hub. Position reverse gear on the mainshaft against 1st speed gear, align reverse gear splines with sliding clutch.
26. At this time remove the air line and insert the mainshaft key. **Be careful not to move the gears while doing this procedure, the limit washers are unlocked and can rotate which would cause the gears to drop.**
27. Install the mainshaft key snap ring.
28. Remove the mainshaft from the vise.
29. On the shaft front, align the sliding clutch missing internal spline with the mainshaft key and install the 4th-Drive gear sliding clutch. Engage the sliding clutch external splines with the 4th speed gear clutching teeth.

Final Check

Make sure reverse gear is against 1st speed gear.

Make sure the mainshaft key is in the keyway.

Make sure the 4th speed sliding clutch is engaged into 4th speed gear.

Input Shaft Assembly

How to Remove the Input Shaft Assembly



H/33-7



H/33-8

Special Instructions

The input shaft assembly is a non-serviceable assembly, one exception is the seal rings which can be purchased and replaced. Use fingers to install the new seal rings.

Special Tools

Typical service tools are needed

Soft hammer

To Remove

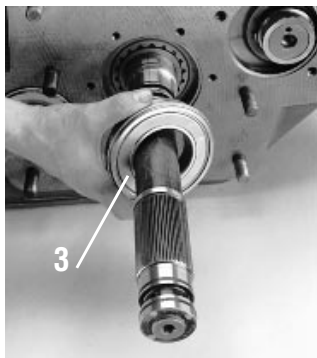

H/35-1

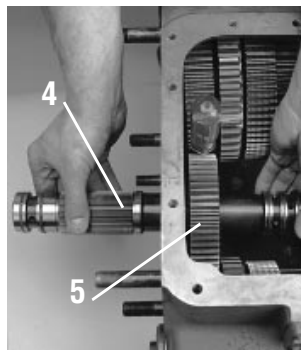

H/33-9

1. From the input shaft groove, remove the bearing retaining snap ring.
2. Use a soft hammer and drive the input shaft toward the case rear as far as possible. Pull the input shaft forward.
3. Use pry bars or screwdrivers to complete removal of the bearing.
4. Push the input shaft through the drive gear and out of the case.
5. From inside the case, remove the drive gear and spacer.
6. Inspect the input shaft bushing, replace if damaged.
7. Remove the input shaft piston rings. They will be replaced during the torque converter housing installation.
8. Inspect the tube inside the input shaft, replace if damaged. Tighten to 65-79 Lb_f·ft of torque.

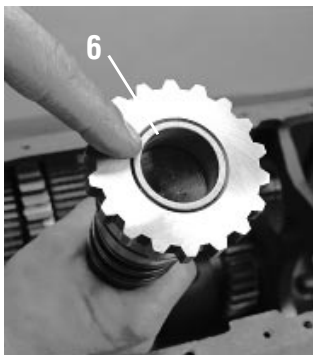

H/34-1

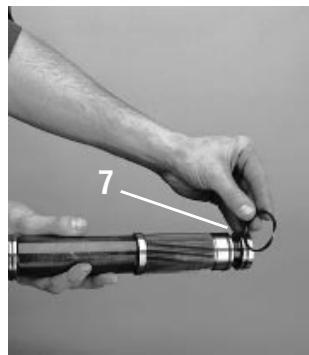

H/34-2



H/34-3

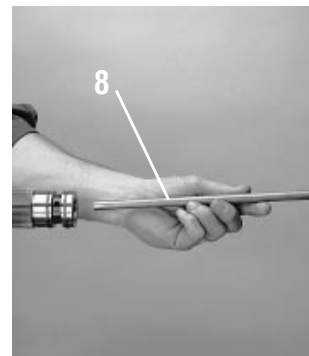

H/34-4

Input Shaft Assembly

How to Install the Input Shaft Assembly

Special Instructions

As part of assembling the input shaft assembly, the mainshaft drive gear must be installed and timed.

Apply Eaton lubricant #71215 or equivalent to the pilot bushing so that a film of lubricant covers the entire internal surface of the bushing.

Special Tools

Typical service tools are needed

Toolmaker's dye

To Install

1. In I.D. of main drive gear, install the snap ring.
2. Use toolmaker's dye and mark the main drive gear for timing purposes.

Mark any two (2) adjacent teeth on the drive gear. Repeat the procedure for the two (2) adjacent teeth directly opposite the first set marked.

3. Position the spacer and main drive gear in the transmission case.
4. Inside the case, mesh the lower countershaft drive gear marked tooth with either set of marked teeth on the main drive gear.
5. Slide the input shaft through the main drive gear.

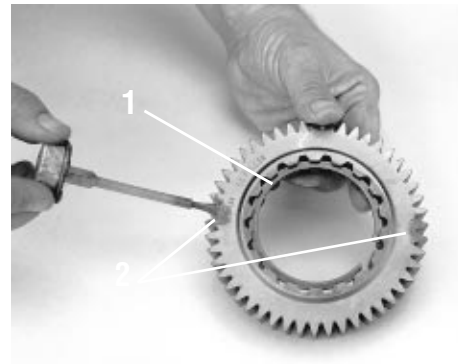

A/20-2

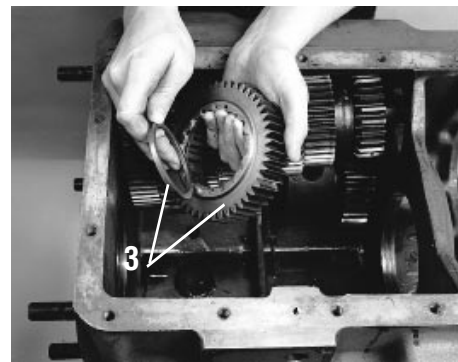

Q/200-7



Q/300-4

continued on next page

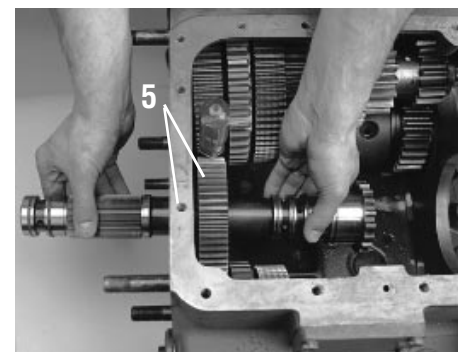

H/33-9

Transmission appearance may differ, procedure is the same.

Input Shaft Assembly

continued

How to Install the Input Shaft Assembly

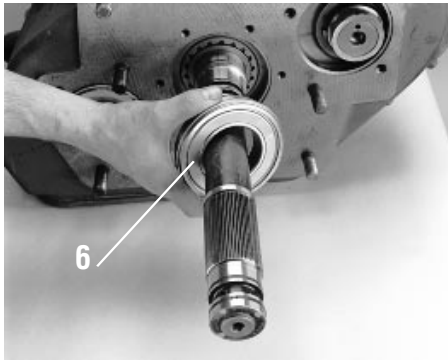

H/35-1

6. With the bearing external snap ring to the outside, position the bearing on the input shaft.
7. Temporarily install two lifting eyes to hold the bearing in the case bore.
8. Use a soft bar and maul to drive the input shaft through the bearing.
9. Install the bearing retainer snap ring in the input shaft snap ring groove.

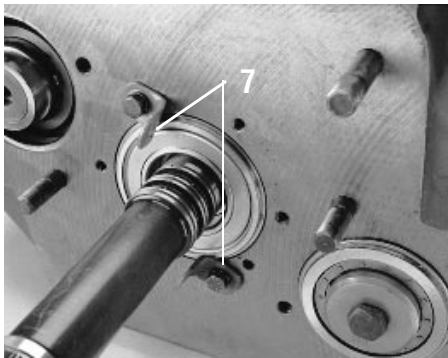

H/35-2

Final Check

Make sure the drive gear is timed with the lower countershaft.

Remove the temporary lifting eyes.

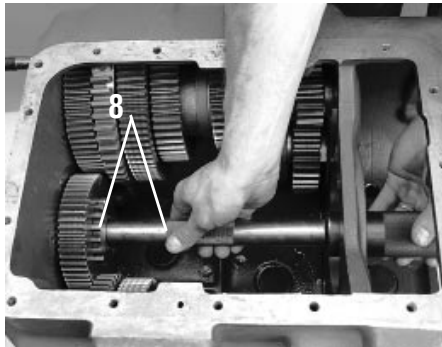

H/35-3

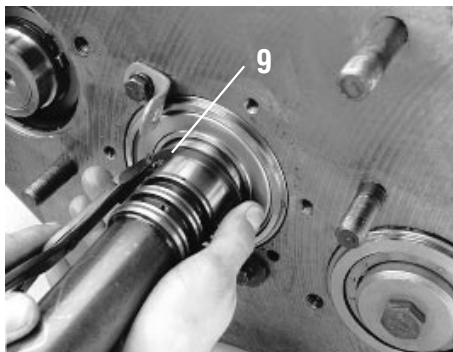

H/35-4



Section 7: Auxiliary Section

How to Disassemble the Auxiliary Section 2

How to Assemble the Auxiliary Section 3

Range Cylinder Assembly

How to Disassemble the Range Cylinder Assembly 4

How to Assemble the Range Cylinder Assembly 5

How to Disassemble the Synchronizer Assembly 6

How to Assemble the Synchronizer Assembly 7

Countershaft Assembly

How to Remove the Countershaft Assembly 8

How to Install the Countershaft Assembly 9

Output Shaft Assembly

How to Disassemble the Output Shaft Assembly 12

How to Assemble the Output Shaft Assembly 13

How to Disassemble the Auxiliary Section

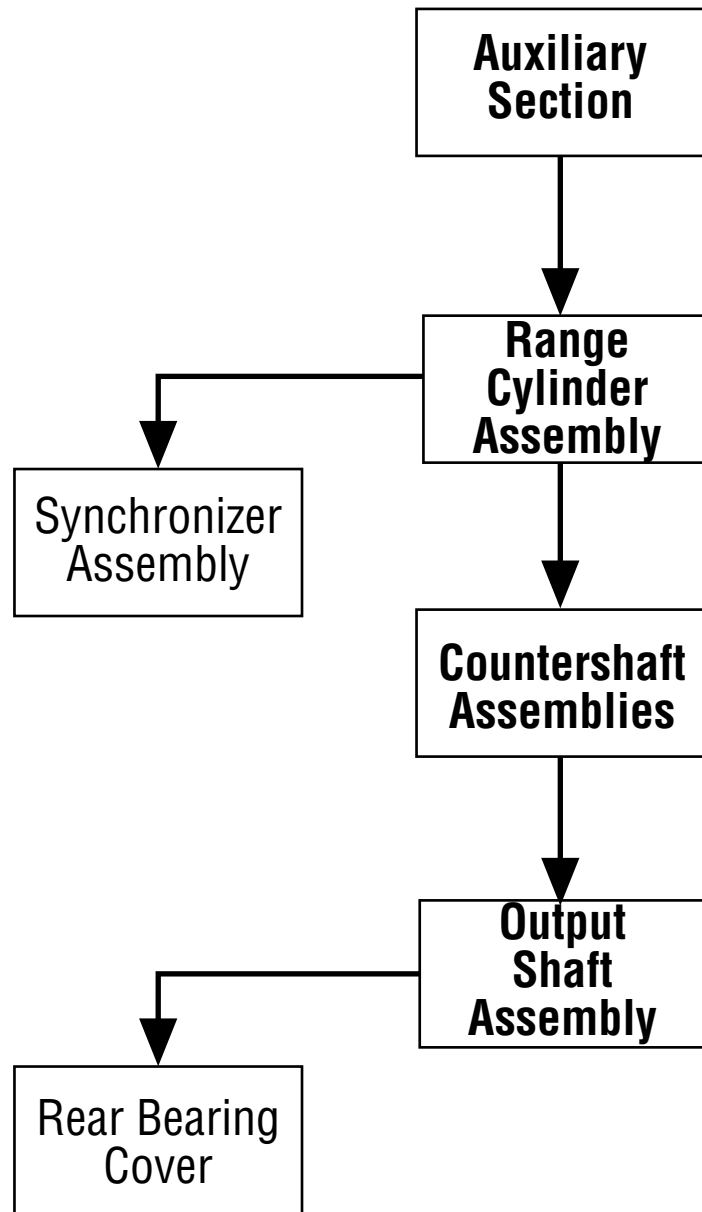

DS/AS-3



How to Assemble the Auxiliary Section

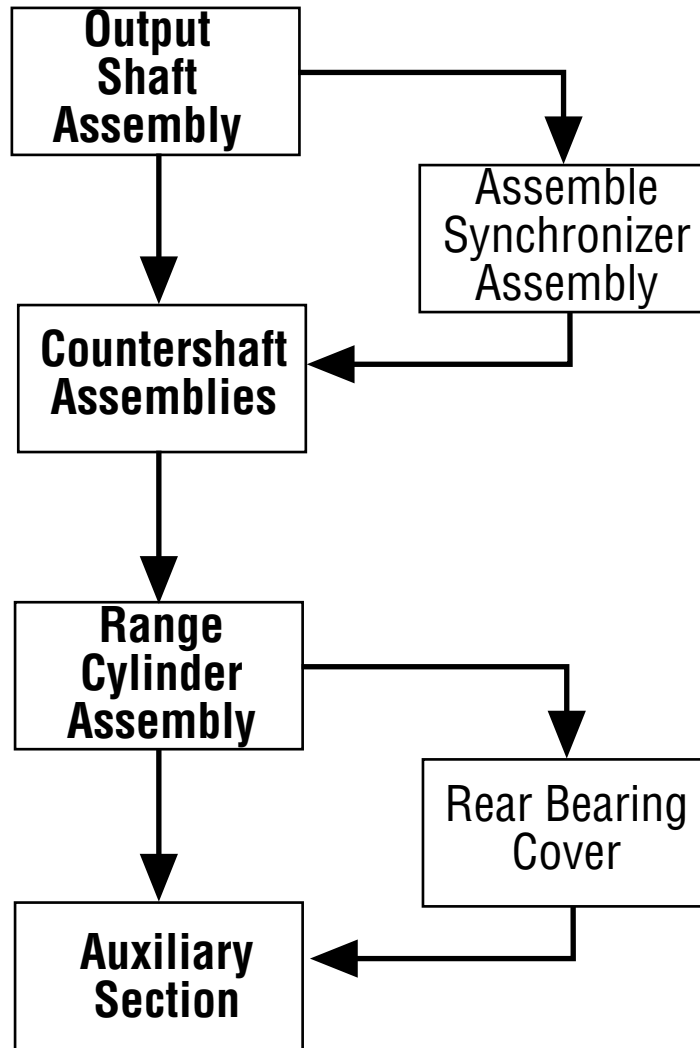

AS/AS-4

Range Cylinder Assembly

How to Disassemble the Range Cylinder Assembly

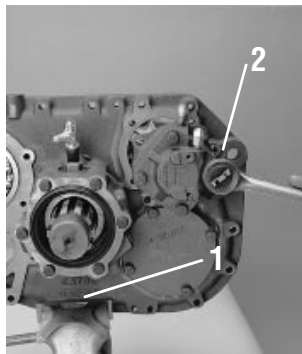

H/29-4

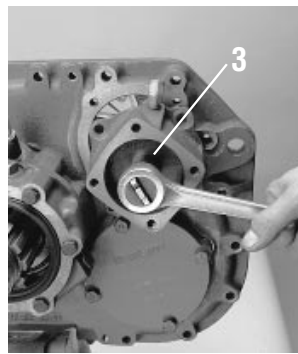

H/29-5

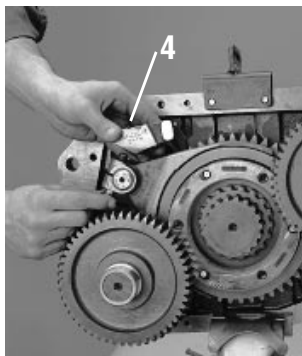

H/29-1

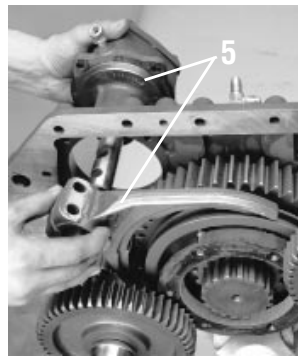

H/29-3

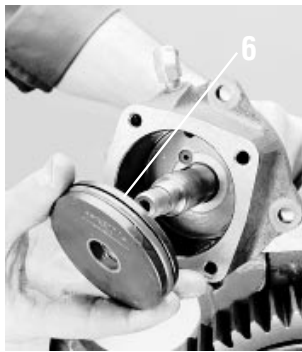

H/29-6



A/06-5

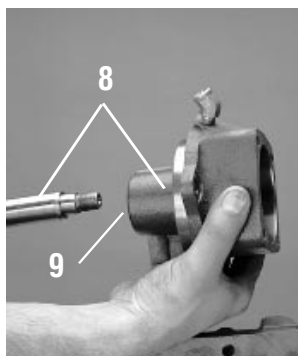

H/29-7

Special Instructions

Apply Eaton Lubricant #71214 or equivalent to the O-rings.

Special Tools

Typical service tools needed

Vise with brass jaws or wood blocks

To Disassemble

1. For ease of disassembly, mount the auxiliary section upright in a vise.
2. Remove the range cylinder cap screws.
3. Loosen the range piston nut.
4. Cut the lockwire on the yoke lock screws and remove the two (2) lock screws and actuating bracket.
5. Remove the range yoke and cylinder housing from the synchronizer assembly sliding clutch.
6. Remove the range piston nut and piston.
7. Inspect the piston O-rings, replace if damaged or distorted.
8. Pull the yoke bar out the range cylinder housing front.
9. Inspect the bushing inside the range cylinder housing, press the bushing out if damaged.

Range Cylinder Assembly

How to Assemble the Range Cylinder Assembly

Special Instructions

Apply Eaton Rust Preventative #71213 to the cylinder walls, cylinder bottom, and the yoke bar. A film should completely cover the surfaces.

Apply Eaton Lubricant #71214 or equivalent to the O-rings.

Apply Eaton lockwire #1819 or equivalent to the actuator capscrews. The wire should anchor the capscrew at least 2 complete 360° turns. The lockwire ends should be trimmed and bent out of the way of any part interference.

Special Tools

Typical service tools needed

To Assemble

1. Inspect the range cylinder O-rings, replace if damaged.
2. From the range cylinder housing front, insert the yoke bar.
3. Install the range piston and nut. Finger tighten.
4. Position a new gasket on the range cylinder housing mounting surface.
5. Install the range cylinder housing and sliding clutch.
6. Install the actuating bracket and capscrews. Tighten the capscrews to 50-65 Lb_f·ft of torque. Wire securely.
7. Tighten the range piston nut to 70-85 Lb_f·ft of torque.
8. Install the cylinder cover capscrews. Tighten the capscrews to 35-45 Lb_f·ft of torque.

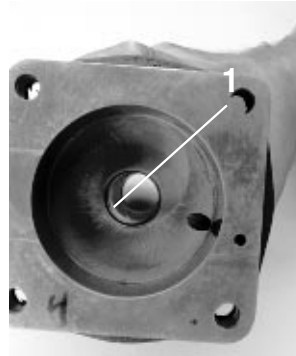

A/06-4

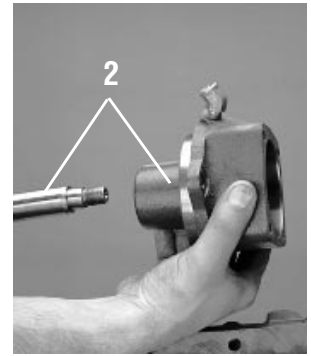

H/29-7



H/29-6

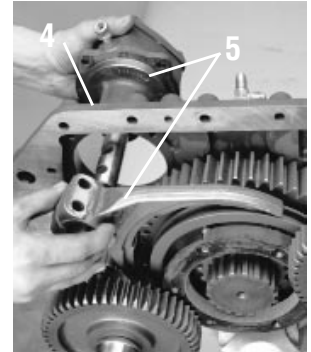

H/29-3

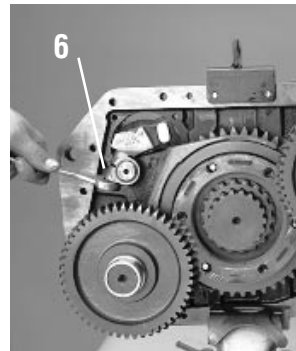

H/28-9

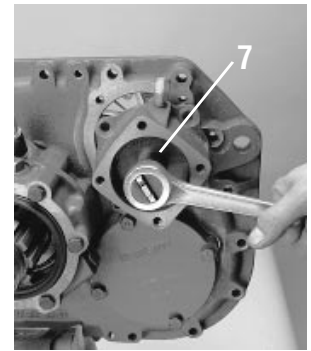

H/29-5

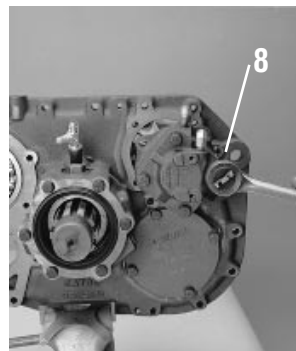

H/29-4

Transmission appearance may differ, procedure is the same.

Range Cylinder Assembly

How to Disassemble the Synchronizer Assembly

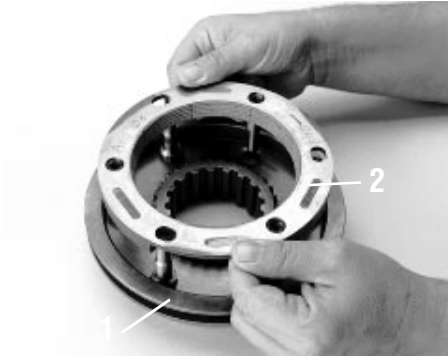

A/07-4

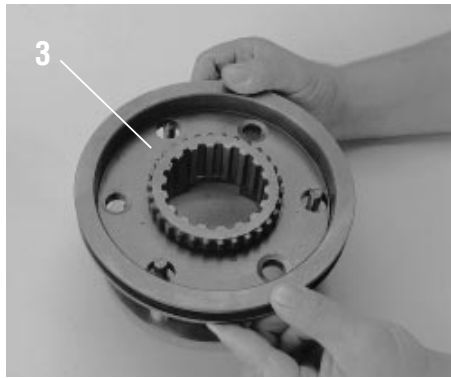

A/07-5

Special Instructions

Place the synchronizer assembly on a clean, flat surface. Cover the synchronizer assembly with a shop rag to prevent losing the three (3) springs under pressure from the HI range synchronizer pin locations.

Special Tools

Shop rag

To Disassemble

1. Place the larger LO range synchronizer ring on the bench.
2. Grab both sides of the HI range synchronizer and pull.
3. From the synchronizer ring LO range pins, remove the sliding clutch.

Range Cylinder Assembly

How to Assemble the Synchronizer Assembly

Special Instructions

Assembly should be done on a clean, flat surface slightly lower than your waist.

Pins on the LO range synchronizer must line up with the chamfered holes on the sliding clutch bottom.

When compressing the HI range synchronizer springs cover with a shop rag. In the event compression is not achieved the first time, this prevents the springs from leaving the bench area.

Special Tools

Shop rag

To Assemble

1. On the bench place the larger LO range synchronizer ring face down with pins up.
2. With the sliding clutch recessed side up, place the sliding clutch on the LO range synchronizer pins.
3. In the HI range synchronizer bores, install the three (3) springs.
4. Place the HI range synchronizer ring over the LO range synchronizer ring. Rotate the HI range synchronizer until the springs are seated against the pins.
5. With the shop rag, cover the assembly.
6. Apply downward pressure to the HI range synchronizer ring while twisting counterclockwise. This compresses the springs to fully seat HI range on the LO range synchronizer.

Final Check

Make sure there are three springs and are fully compressed.

Make sure you can move the sliding clutch from HI to LO range and back.

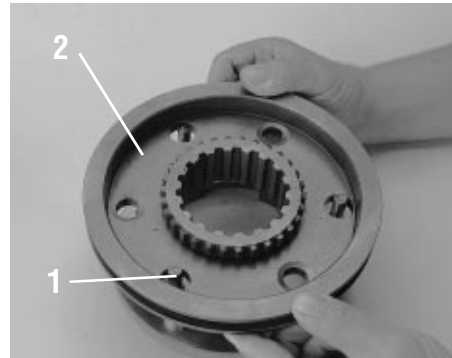

A/07-5

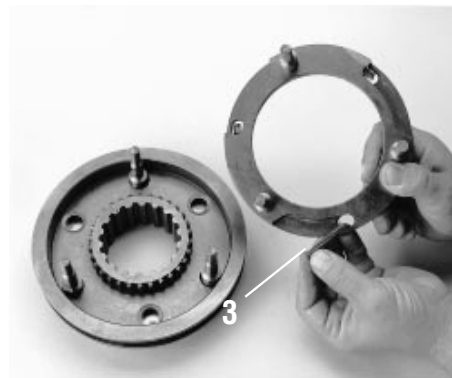

A/07-6

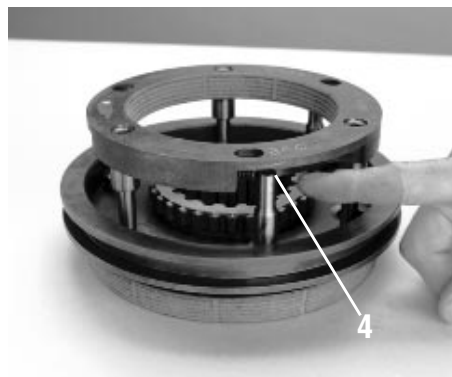

A/07-8

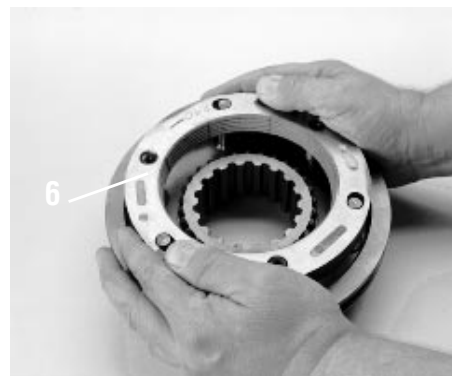

A/07-9

Transmission appearance may differ, procedure is the same.

Countershaft Assembly

How to Remove the Countershaft Assembly

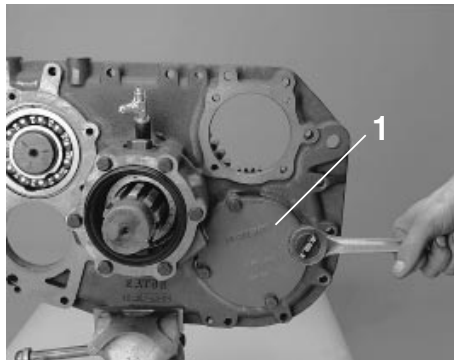

H/29-8

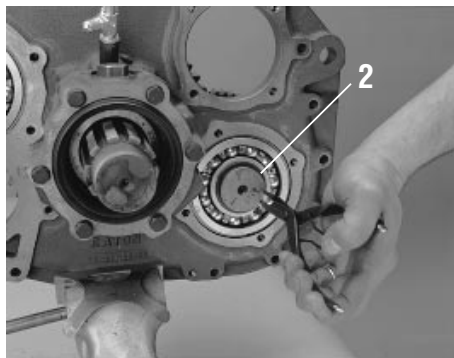

H/29-9

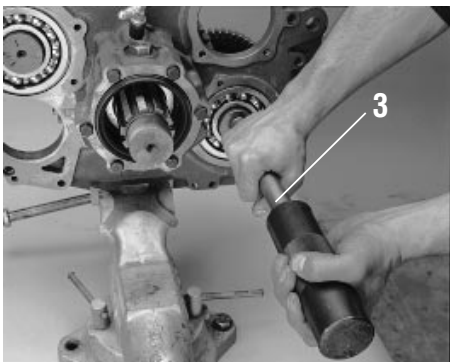

H/30-1

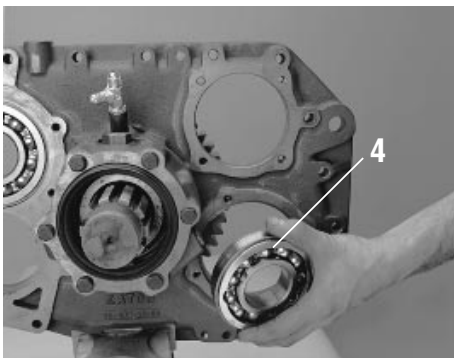

H/30-2

Special Instructions

Both countershafts are removed the same.

When driving the countershaft to the rear, be careful not to damage the bearing inner race.

Special Tools

Typical service tools are needed

Vise with brass jaws or wood blocks

Gear Puller

Soft bar and Maul

To Disassemble

1. Remove the auxiliary countershaft rear bearing cover capscrews and remove the auxiliary countershaft rear bearing cover and gasket.
2. Remove the snap ring from the countershaft rear groove.
3. Use a soft bar and maul to drive the countershaft forward and from the rear bearings.
4. Remove the bearing from the auxiliary housing bore by tapping lightly and evenly to the rear with a soft bar.
5. If necessary, secure the assembly in a vise and remove the bearing inner race from the countershaft front with a gear puller.

Countershaft Assembly

How to Install the Countershaft Assembly

Special Instructions

When installing the countershaft assemblies into the countershaft bearings, keep the countershaft assemblies straight. Do not cock the countershafts. If, when the countershaft bearing cover is removed and you can not see the snap ring groove, install the cover and drive the countershaft further until you can see the groove.

Make sure the synchronizer assembly springs were not released from the HI range ring bores during bearing installation. If the springs release, see "How to Assemble the Synchronizer Assembly".

Special Tools

Typical service tools are needed
Vise with brass jaws or wood blocks
Bearing driver and maul
Toolmaker's dye
Large snap ring pliers

To Assemble

1. Place the countershaft assembly vertical on a clean, flat surface. If previously removed, using the proper driver and maul install the countershaft bearing race.
2. In the countershaft rear bearing bore, using the proper driver and maul, install the countershaft bearing.
3. Temporarily install the rear bearing cover, use two (2) capscrews and no gasket. The cover holds the bearing as the countershaft is driven into the bearing.
4. Use toolmaker's dye and mark the LO range gear tooth with an "O" for timing purposes.
5. Position the countershaft assemblies in the auxiliary housing. Mesh the countershaft LO range gear marked tooth.
6. Center the countershaft rear in the bearing bore, complete installation with a soft bar and maul.

continued on next page

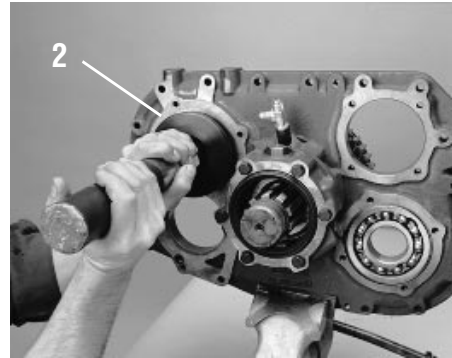

H/31-3

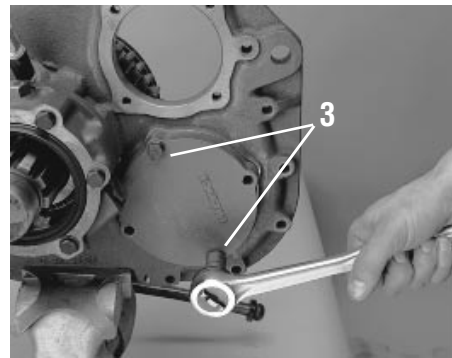

H/31-5

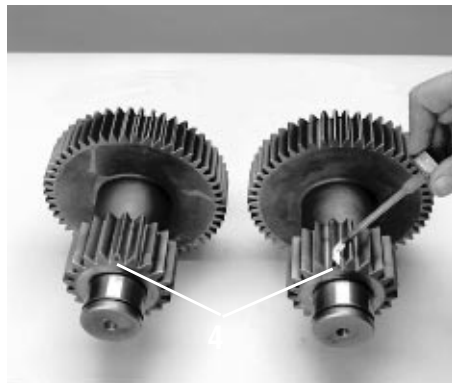

A/09-1(a)

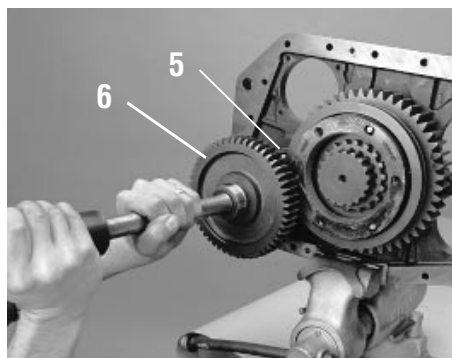

H/31-6

Transmission appearance may differ, procedure is the same.

Countershaft Assembly

continued

How to Install the Countershaft Assembly

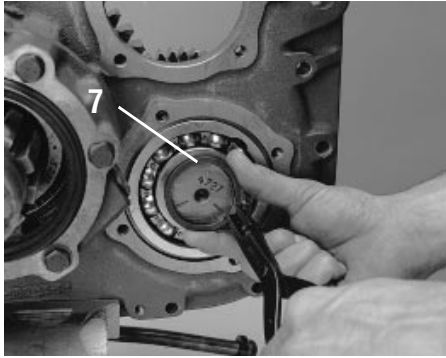

H/31-7

To Assemble

7. Remove the rear bearing cover and install the retaining snap ring in the countershaft rear snap ring groove.
8. Position a new gasket on the rear bearing cover mounting surface and install the rear bearing cover.
9. Apply sealant/adhesive and install the capscrews, tighten to 35-45 Lb_f·ft of torque.

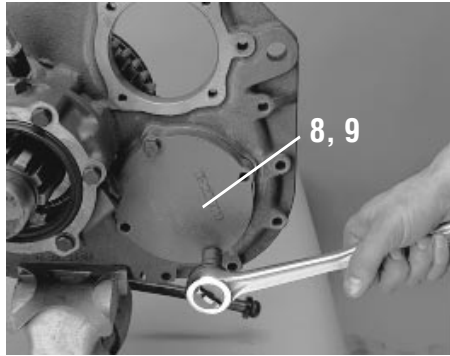

H/31-5

Output Shaft Assembly

How to Disassemble the Output Shaft Assembly

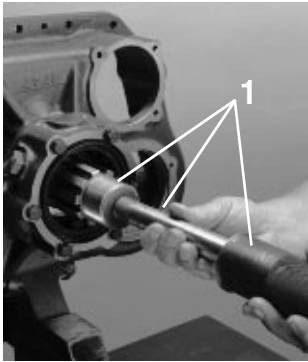

A/05-1

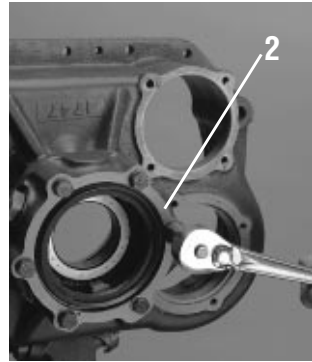

A/05-2



A/09-3

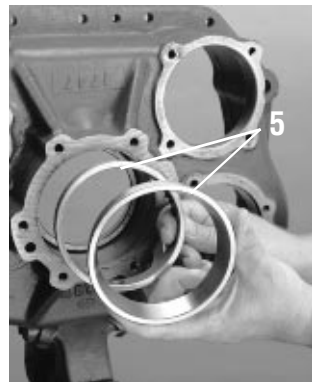

A/05-3



A/05-4



A/08-1

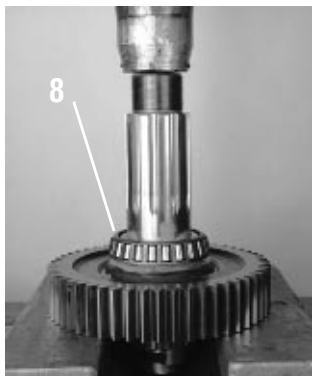

A/09-6

Special Instructions

When using the soft bar and maul on the output shaft, be careful not to damage the threads.

When removing the rear bearing cover, the rear bearing cone drops from the housing bore.

Special Tools

Typical service tools are needed

Vise with brass jaws or wood blocks

Press

Soft bar and Maul

To Disassemble

1. Use a soft bar and maul to drive the output shaft forward and through the rear bearing assembly.
2. From the auxiliary housing rear, remove the rear bearing retaining capscrews, cover, and gasket.
3. Clean the gasket mounting surface of gasket material.
4. Inspect the rear bearing cover oil seal for damage, remove if damaged.
5. From the auxiliary housing rear, remove the bearing cup and spacer.
6. From the auxiliary housing front, remove the remaining bearing cup.
7. From the output shaft, remove the bearing inner spacer.
8. Use the output shaft assemble gear front face as a base, press the output shaft through the bearing and gear.

Output Shaft Assembly

How to Assemble the Output Shaft Assembly

Special Instructions

Make sure the magnetic plugs are installed in the auxiliary housing.

Output shaft stack up should be done on a clean, flat surface.

When heating the bearings, do not heat bearings above 275°F (136°C).

When installing the rear bearing oil seal, press into the rear bearing cover flush with the machined step. A thin coat of lubrication may be used on the seal O.D.

Because the collar becomes distorted when compressed, **do not re-use an old nylon collar** in the rear bearing cover.

Apply Eaton Lubricant #71214 or equivalent to speedometer plug O-rings, cover the entire surface. If the electronic sensor hole has a seal, apply lubricant #71214 or equivalent, covering the top surface. **Do not use an O-ring with the seal.**

Special Tools

Typical service tools are needed

Toolmaker's dye

Heat lamp or hot plate and oil

Oil seal installation tool

To Assemble

1. Use toolmaker's dye and mark the LO range gear for timing purposes.

Mark any two (2) adjacent teeth on the LO range gear. Repeat the procedure for the two (2) adjacent teeth directly opposite the first set marked.

2. For models so equipped, install the stepped washer, step down.
3. With the large diameter spline down, place the washer on the output shaft shoulder.
4. With LO range gear clutching teeth down, position LO range gear on the output shaft, engage the washer splines.

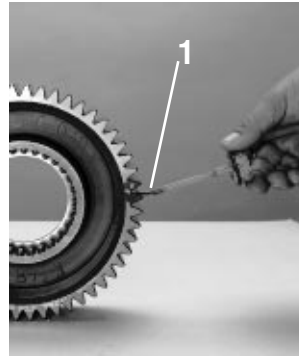

A/08-8



S/35-1

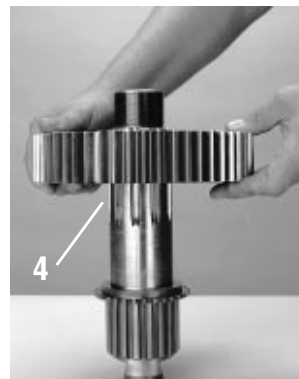

A/08-6

continued on next page

Transmission appearance may differ, procedure is the same.

Output Shaft Assembly

continued

How to Assemble the Output Shaft Assembly

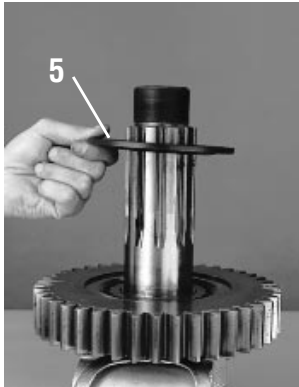

S/35-3



A/08-2



A/08-1

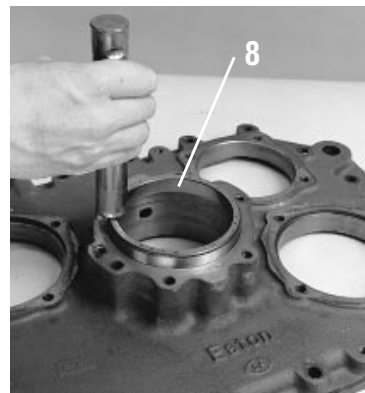

S/35-6



S/35-7

5. With chamfer side up, position the LO range gear rear washer on the output shaft against the LO range gear.
6. With tapered side up, use heat or appropriate driver and install the output shaft front rear bearing.
7. On the output shaft, position the bearing inner spacer. Set aside.
8. Lay the auxiliary housing front face down on a clean, flat surface. Install the front bearing cup.
9. Install the rear bearing spacer and rear bearing race in the bearing bore.
10. Place the rear bearing cup against the spacer. Use a flanged-end driver to move all three (3) parts evenly into the bore until the rear bearing cup lip seats on the auxiliary plate.

Output Shaft Assembly

continued

How to Assemble the Output Shaft Assembly

11. With the auxiliary housing rear up, set the housing over the output shaft.
12. With tapered side down, use heat or appropriate driver and install the output shaft rear bearing.
13. Position a new gasket on the rear bearing cover mounting surface, making sure the gasket oil return holes align with the case oil return holes.
14. If previously removed, use an oil seal installation tool and install the oil seal in the rear bearing cover.
15. Position the rear bearing cover over the new gasket.
16. Apply Eaton/Fuller Sealant #71205 or equivalent to the retaining capscrews.
17. On AT/ATR/ATS models, use a new nylon collar and brass washer at the chamfered hole, the hole that intersects the speedometer bore.
18. Install the retaining capscrews, tighten to 35-45 Lb_f·ft of torque.

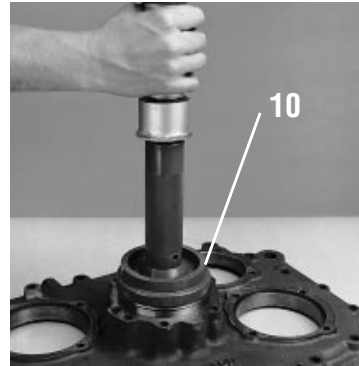

S/35-8

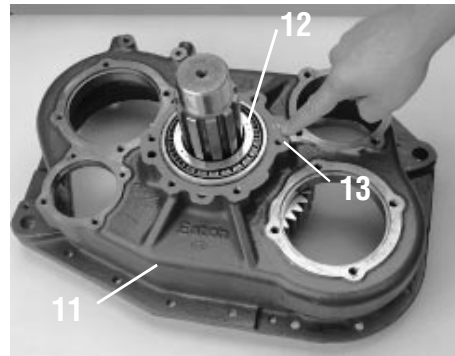

A/09-8

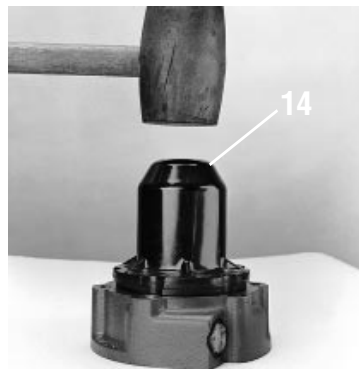

V/08-1

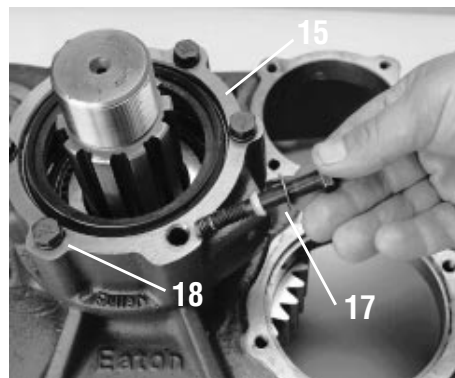

A/10-3

Final Check

Make sure the rear bearing is seated.

Make sure the rear bearing capscrews are properly torqued.

Make sure the output shaft rotates freely.

Transmission appearance may differ, procedure is the same.

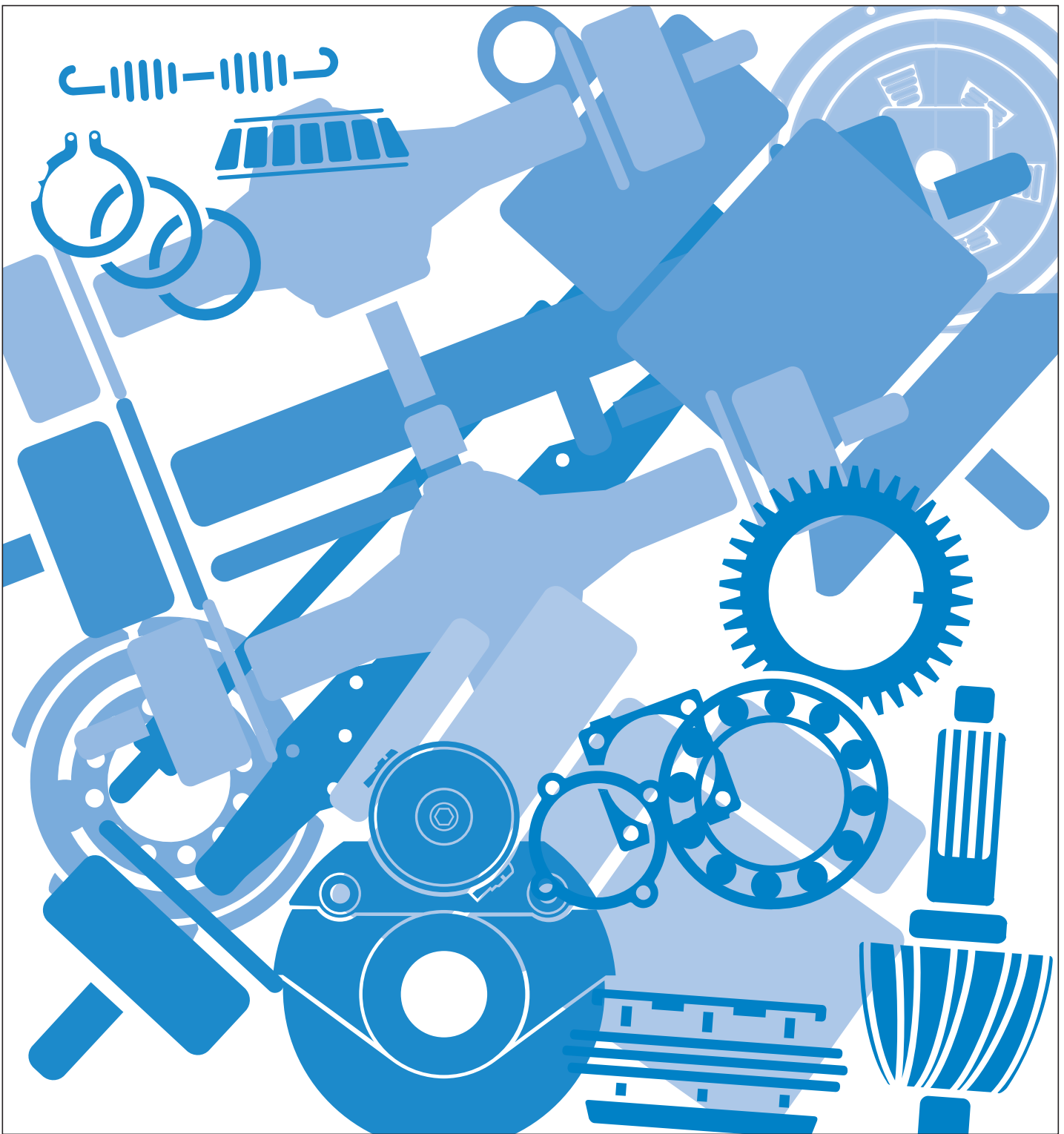

Copyright Eaton and Dana Corporation, 2002. EATON AND DANA CORPORATION hereby grants its customers, vendors, or distributors permission to freely copy, reproduce and/or distribute this document in printed format. THIS INFORMATION IS NOT INTENDED FOR SALE OR RE-SALE, AND THIS NOTICE MUST REMAIN ON ALL COPIES.



National Institute for
**AUTOMOTIVE
SERVICE
EXCELLENCE**

Roadranger®

MORE TIME ON THE ROAD

The Roadranger® System is an unbeatable combination of the best products from Eaton and Dana – partnering to provide you the most advanced, most trouble-free drivetrain in the industry. And it's backed by the Roadrangers – the most experienced, most expert, most accessible drivetrain consultants in the business.

For spec'ing or service assistance, call 1-800-826-HELP (4357) 24 hours a day, 7 days a week, (Mexico: 001-800-826-HELP (4357)) for more time on the road. Or visit our web site at www.roadranger.com.



EAT•N

One Great Drivetrain from Two Great Companies

TRSM-0020
12/93 PDF
Printed in USA