

SERVICE MANUAL
MOYNO® 500 PUMPS
300 Series Motorized
35650, 35651, 35652, 36750, 36751, and 36752 Model

DESIGN FEATURES

Housing: Cast iron/316 SS
 Pump Rotor: AISI 416 stainless steel/ANSI 316 SS
 Pump Stator: NBR
 Seal: NBR (Nitrile)
 Motor Shaft: Mechanical (carbon/ceramic)
 Motor: 3 phase; 1-1/2 HP, 208/230/460V for Models 35650 and 35651; 2 HP, 230/460V for Models 36751 and 36750; 1 phase; 1-1/2 HP, 115/230V for Model 35652; 1 phase; 2 HP, 115/230V for Model 36752.60 Hertz, 1725 rpm, totally enclosed

Note: Alternate elastomers available. Refer to Repair/ Conversion Kit Numbers, page 4.

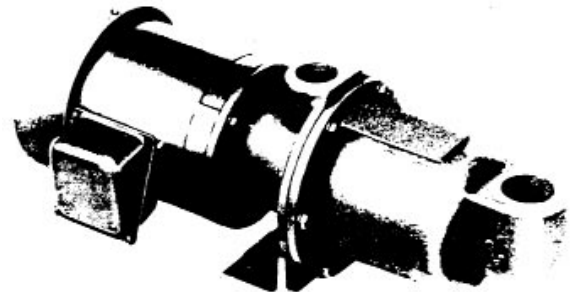

INSTALLATION

Mounting Position. Pump may be mounted in any position. When mounting vertically, it is necessary to keep bearings above seals to prevent possible seal leakage into bearings.

Pre-Wetting. Prior to connecting pump, wet pump elements and mechanical seal by adding fluid to be pumped into suction and discharge ports. Turn pump over several times in a clockwise direction to work fluid into pump elements.

Piping. Piping to pump should be self-supporting to avoid excessive strain on pump housings. See Table 1 for suction and discharge port sizes of each pump model.

Use pipe "dope" or tape to facilitate disassembly and to provide seal on pipe connections.

Electrical. Follow the wiring diagram on the motor nameplate or inside the terminal box for the proper connections. The wiring should be direct and conform to local electrical codes. Check power connections for proper voltage. Voltage variations must not exceed + 10% of nameplate voltage. Motors do not have overload protection.

To prevent damage to pump, pump rotation must be clockwise when facing pump from motor end.

OPERATION

Self-Priming. With wetted pumping elements, the pump is capable of 25 ft. suction lift with pipe size equal to port size. Be sure suction lines are air tight or pump will not self-prime.

DO NOT RUN DRY. Unit depends on liquid pumped for lubrication. For proper lubrication, flow rate should be at least 10% of rated capacity.

Pressure and Temperature Limits. See Table 1 for maximum discharge pressure of each model. Unit is suitable for service at temperatures shown in Table 2.

Storage. Always drain pump for extended storage periods by removing bottom drain plug. To drain Model 36750, 36751 and 36752 remove suction housing bolts and loosen suction housing.

Caution: Suction pressure should never be greater than discharge pressure.

Table 1. Pump Data

Pump Model	356	367
Suction Port (NPT)	1-1/2	2
Discharge Port (NPT)	1-1/4	1-1/4
Voltage Rating (VAC)	See Motor Name Plate For Voltage Ratings	See Motor Name Plate For Voltage Ratings
Discharge Pressure (psig) (maximum)	50	50

NOTE: SSU = $\frac{5 \times \text{CP}}{\text{specific gravity}}$ (approximate)

Table 2. Temperature Limits

Elastomer	Temperature Limits
*NBR	10°-160°F
*EPDM	10°-210°F
*FPM	10°-240°F

*NBR = Nitrile

EPDM = Ethylene-Propylene-Diene Terpolymer

FPM = Fluoroelastomer

TROUBLE SHOOTING

WARNING: Before making adjustments, disconnect power source and thoroughly bleed pressure from system. Failure to do so could result in electric shock or serious bodily harm.

Failure To Pump.

1. Motor will not start: Check power supply. Voltage must be $\pm 10\%$ of nameplate rating when motor is in locked rotor condition.
2. Motor runs and thermally kicks out: Check for excessive pressure. Increase ventilation to motor. Do not use less than #14 wire size.
3. Stator torn; possible excessive pressure: Replace stator, check pressure at discharge port.
4. Flexible joint broken; possible excessive pressure: Replace joint, check pressure at discharge port.
5. Wrong rotation: Rotation must be clockwise when facing pump from motor end. Reverse the connections of any two line leads to the motor.
6. Excessive suction lift or vacuum.

Pump Overloads.

1. Excessive discharge pressure: Check pressure at discharge port for maximum ratings given in Table
2. Fluid viscosity too high: Limit fluid viscosity to 100 CP or 500 SSU.

Noisy Operation.

1. Excessive suction lift or vacuum: Maximum suction lift is 25 feet for water.
2. Suction line too small: Check pipe size. Be sure lines are free from obstructions.
3. Pump cavitates: Pump speed is 1725 rpm. Viscosity of fluid should not exceed 100 CP or 500 SSU.
4. Flexible joint worn: Replace joint. Check pressure at discharge port.
5. Insufficient mounting: Mount to be secure to a firm base. Vibration induced noise can be reduced by using mount pads and short sections of hose on suction and discharge ports.

Seal Leakage.

1. Leakage at startup: If leakage is slight, allow pump to run several hours to let faces run in.
2. Persistent seal leakage: Faces may be cracked from freezing or thermal shock. Replace seal.

Pump Will Not Prime.

1. Air leak on suction side: Check pipe connections.

PUMP DISASSEMBLY

WARNING: Before disassembling pump, disconnect power source and thoroughly bleed pressure from system. Failure to do so could result in electric shock or serious bodily harm.

1. Disconnect power source.
2. Remove suction and discharge piping.
3. Remove screws (112) holding suction housing (2) to discharge housing (1). Remove suction housing (2) and stator (21).
4. Rotor (22) can be detached from flexible joint (24) by using a punch to remove rotor pin (45). Support joint when removing pin.
5. Flexible joint (24) can be removed from motor shaft by using a punch through the discharge port to remove shaft pin (46).
6. Carefully slide mechanical seal (69) off motor shaft.
7. Remove discharge housing (1) from motor (70) by removing screws (112A and 112C) and washers (215).
8. Carefully pry seal seat out of discharge housing (1). If any part of mechanical seal (69) is worn or broken, the complete assembly should be replaced. Seal components are matched parts and not interchangeable.
9. Remove slinger ring (77).

PUMP ASSEMBLY

1. Replace slinger ring (77).
2. Attach discharge housing (1) to motor (70) using lock washers (215) and body screws (112A).
3. Install mechanical seal (69) using the following procedures:
 - a. Clean and oil sealing faces using light oil (not grease).

Caution: Do not use oil on EPDM parts. Substitute glycerin or soap and water.

- b. Oil the outer surface of seal seat, and push assembly over motor shaft into the bore of the discharge housing (1) seating it firmly and squarely.
 - c. After cleaning and oiling the shaft, slide the seal body along the shaft until it meets the seal seat.
 - d. Install seal spring and spring retainer on shaft.
4. On Model 367, position seal spacer (69A) on motor shaft with slots away from seal (69).
 5. Pin flexible joint (24) to motor shaft with shaft pin (46) using a punch through the discharge port.
 6. Pin rotor (22) to flexible joint using rotor pin (45). Support joint while installing pin.
 7. Slide stator (21) on rotor (22) carefully locating stator flange in housing groove.
 8. Secure stator (21) and suction housing (2) to discharge housing (1) using screws (112).
 9. Proceed as in installation instructions.

When ordering parts, please specify pump model number, pump serial number, part number, part description and quantity.

MODEL 35650, 35651, 35652

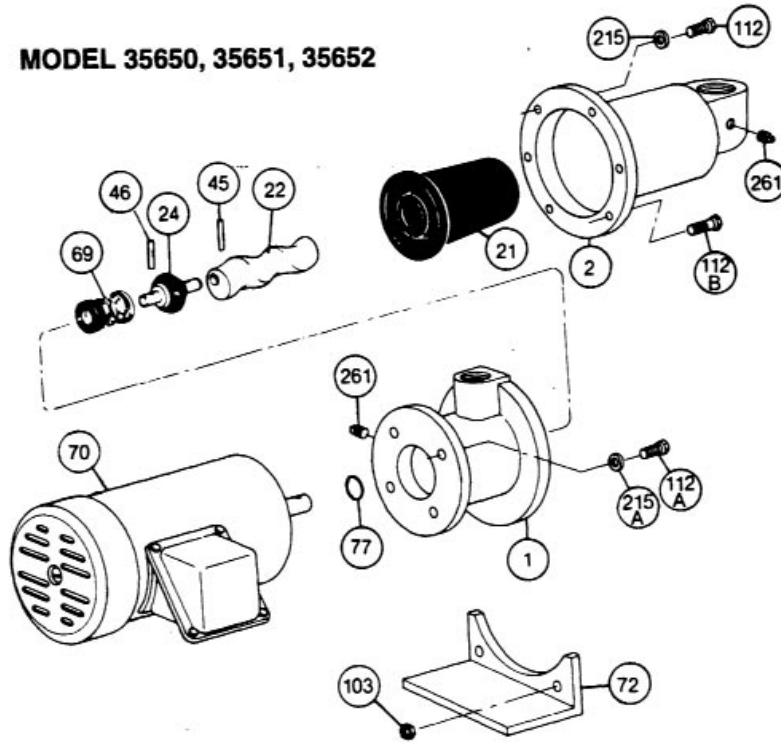

MODEL 36750, 36751, 36752

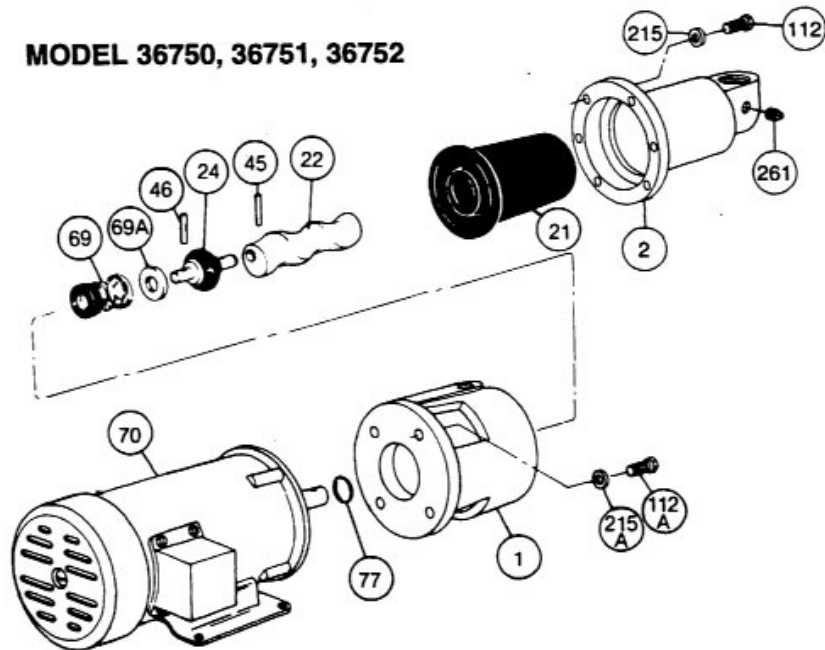

PARTS LIST

Item No.	Description	Pump Model Numbers					
		35650	35651	35652	36750	36751	36752
1	Discharge Housing	350-0632-007	350-0632-000	350-0632-007	340-0951-007	340-0951-000	340-0951-007
2	Suction Housing	350-0489-000	350-0280-000	350-0489-000	350-0302-007	350-0302-000	350-0302-007
*21	Stator	340-3505-120		340-3506-120			
*22	Rotor	320-6392-015	320-6392-000	320-4431-000	330-3077-000	330-2042-000	330-3077-000
24	Flexible Joint	320-1618-000			320-1749-000		
*45	Rotor Pin	320-4069-003			320-4439-002		
*46	Motor Pin	320-4069-005			320-4439-001		
*69	Mechanical Seal	320-3945-000			320-1750-000		
69A	Seal Spacer				320-1737-000		
70	Motor	330-7845-003	330-7845-000	330-8054-002	330-2802-004	300-2802-001	330-8053-004
72	Motor Support	320-4446-000					
77	Slinger Ring	320-6385-000					
103	Nuts (2 req.)	614-0010-111 (3/8-16)					
112	Screw, Hex Hd	619-1530-161 (3/8-16 x 1) (4 req.)			619-1530-161 (3/8-16 x 1) (6 req.)		
112A	Screw, Hex Hd (4 req.)	619-1530-161 (3/8-16 x 1)			619-1550-161 (1/2-13 x 1)		
112B	Screw, Hex Hd (2 req.)	320-6918-000 (3/8-16 x 1-3/4)					
215	Lock Washer	623-0010-411 (3/8) (4 req.)			623-0010-411 (3/8) (6 req.)		
215A	Lock Washer (4 req.)	623-0010-411 (3/8)			623-0010-431 (1/2)		
261	Pipe Plug	610-0120-011 (1/8 NPT)					

* Recommended spare parts

REPAIR/CONVERSION KIT NUMBERS (For cast iron pumps only)

Item No	Description	Model 35651			Model 36751		
		NBR	EPDM	FPM	NBR	EPDM	FPM
-	Kit No.	311-9123-000	311-9125-000	311-9126-000	311-9060-000	311-9036-000	311-9124-000
21	• Stator	340-3505-120	340-3505-320	340-3505-520	340-3506-120	340-3506-320	340-3506-520
24	• Joint	320-1618-000	320-6508-000	320-6509-000	320-1749-000	320-6378-000	320-6515-000
69	• Seal	320-3945-000	320-6380-000	320-6510-000	320-1750-000	320-6390-000	320-6517-000
46	• Pin (Motor)	320-4069-005			320-4439-001		
45	• Pin (Rotor)	320-4069-003			320-4439-002		

*NBR = Nitrile
 EPDM = Ethylene-Propylene-Diene Terpolymer
 FPM = Fluoroelastomer

ABRASION RESISTANT SEALS

Elastomer	Models	
	356	367
NBR	320-6505-000	320-6511-000
EPDM	320-6506-000	320-6512-000
FPM	320-6507-000	320-6513-000