

INSTALLATION, OPERATION AND SERVICE MANUAL

ABS AIR BAG LIFT

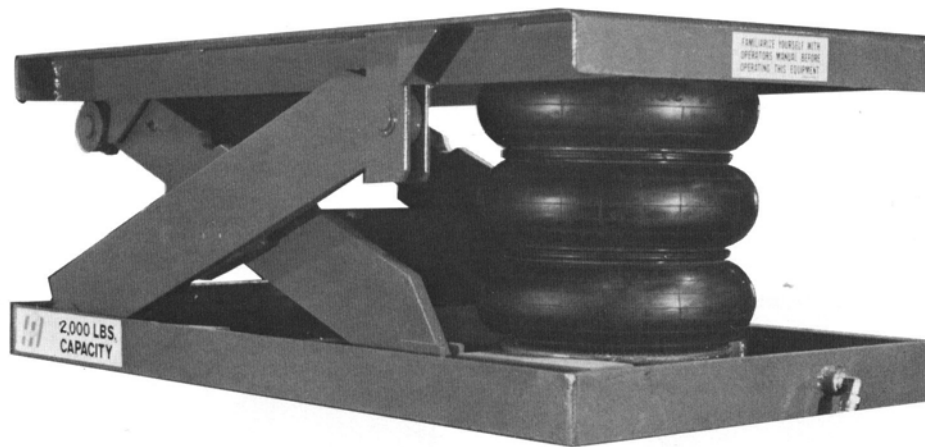

P.O. Box 1058 • 1058 West Industrial Avenue • Guthrie, OK 73044-1058 • 405-282-5200 •
FAX: 405-282-8105 • www.autoquip.com

Item # 830ABS

Version 1.0
07/2001

TABLE OF CONTENTS

Identification and Inspection	3
Dangers and Warnings	4
Label Identification	7
Specifications	10
Lift Blocking Instructions	11
Installation Instructions	12
Operating Instructions	14
Routine Maintenance	15
General Maintenance	16
Replacement Parts List	19
Troubleshooting Analysis	20

IMPORTANT

Please read and understand this manual prior to installation or operation of this lift. Failure to do so could lead to property damage and/or serious personal injury. If any questions arise, call a local representative or *Autoquip Corporation* at 1-888-811-9876 or 405-282-5200.

PLANNED MAINTENANCE PROGRAM

A local *Autoquip* representative provides a Planned Maintenance Program (PMP) for this equipment using factory-trained personnel. Call a local representative or *Autoquip Corporation* at 1-888-811-9876 or 405-282-5200 for more information.

IDENTIFICATION & INSPECTION

IDENTIFICATION

When ordering parts or requesting information or service on this lift, PLEASE REFER TO THE MODEL AND SERIAL NUMBER. This information is on a nameplate attached to the leg assembly. Replacement parts are available from a local *Autoquip* distributor.

INSPECTION

Immediately upon receipt of the lift, a visual inspection should be made to determine that it has not been damaged in transit. Any damage found must be noted on the delivery receipt. In addition to this preliminary inspection, the lift should be carefully inspected for concealed damage. Any concealed damage found that was not noted on the delivery receipt should be reported in writing to the delivering carrier within 48 hours.

The following is a checklist that will aid in the inspection of this lift.

1. Examine the entire unit for any signs of mishandling.
2. Pay special attention to the air bag and hosing.
3. Thoroughly examine all connections, making sure they have not vibrated loose during transit.
4. After installation, raise and block the lift and inspect the base frame, scissors assembly and air bag. See the "Lift Blocking Instructions" section.

DANGERS, WARNINGS & CAUTIONS

SAFETY ALERTS (Required Reading!)

The following SAFETY ALERTS are intended to create awareness of owners, operators, and maintenance personnel of the potential safety hazards and the steps that must be taken to avoid accidents. These same alerts are inserted throughout this manual to identify specific hazards that may endanger uninformed personnel. Identification of every conceivable hazardous situation is impossible. Therefore, all personnel have the responsibility to diligently exercise safe practices whenever exposed to this equipment.



DANGER!

Identifies a hazardous situation that presents the imminent probability of death or of severe personal injury!!



WARNING!

Identifies a hazardous situation that has the potential of causing death or serious personal injury.



CAUTION!

Identifies a hazardous situation that could lead to the possibility of personal injury of death, and/or may result in equipment damage.

DANGERS, WARNINGS & CAUTIONS

Read and understand this manual and all labels prior to operating or servicing this lift. All labels are provided in accordance with ANSI Z535.4.



DANGER!

Do not work under lift without Maintenance Device! To avoid personal injury, NEVER go under the lift platform until the load is removed and the platform is securely blocked in the open position. See "Lift Blocking Instructions" section.



DANGER!

To avoid personal injury, stand clear of scissors leg mechanism while lift is in motion.



DANGER!

Do not inflate air bags to more than 80 PSI.



WARNING!

NEVER stand, sit or ride on the lift!

DANGERS, WARNINGS & CAUTIONS



WARNING!

All warning and information decals should be in place as outlined in the “Label Identification” section. If decals are missing or damaged, they should be replaced with new ones. Contact an *Autoquip* representative for replacements.



CAUTION!

When moving the lift, do not attempt to pick it up by the platform; it is hinged and could be damaged. Pick up from under the base frame **ONLY**.



CAUTION!

Do not continue to activate the “UP” valve if the lift is not raising or if it has reached the fully raised position. To do so may result in permanent damage to the lift.

LABEL IDENTIFICATION

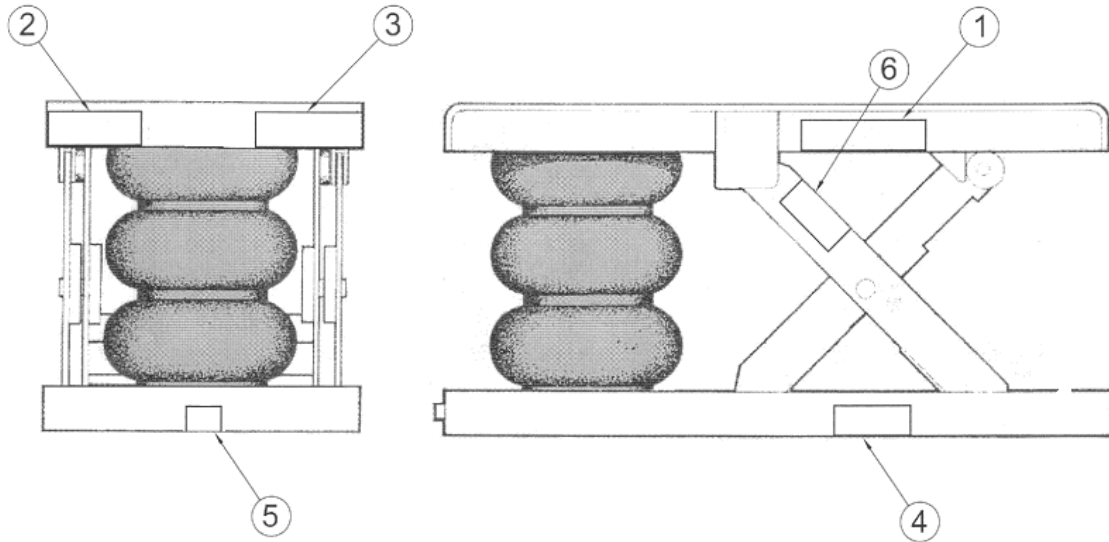

Figure 1 Label Placement Diagram

Air Force Lift			
Item No.	Qty	Description	Part No.
1	2	Danger – Do Not Put Hands or Feet . . .	36430050
2	2	Max. Capacity	36405710
3	2	Caution – Familiarize Yourself with Operators Manual	36401487
4	1	Do Not Inflate To More Than 80 PSI	36401628
5	1	Maint. Device	36400257
6	1	<i>Autoquip</i> Serial Number Nameplate	36401511



Note: Labels shown here are not actual size.



Figure 2 Label 36430050



Figure 3 Label 36405710



Figure 4 Label 36401487



Figure 5 Label 36401628

LABEL IDENTIFICATION

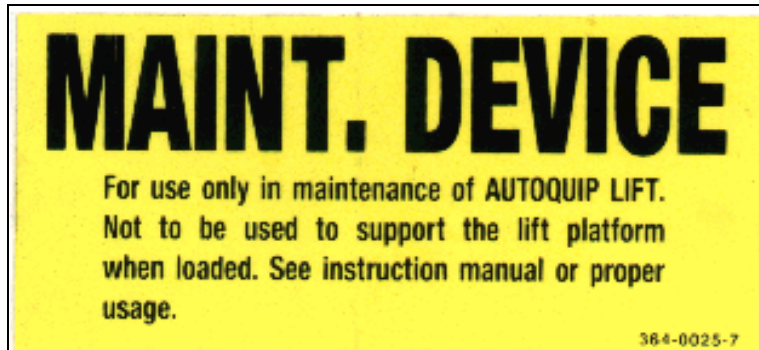

Figure 6 Label 36400257



Figure 7 Label 36401511

SPECIFICATIONS

Model	Travel	Capacity (pounds)	Lowered Height	Load End (pounds)	Load Side (pounds)	Standard Plat. Size	Maximum Plat. Size
5ABS20	5"	2,000	6 ½"	2,000	2,000	24" x 48"	48" x 96"
5ABS 40	5"	4,000	6 ½"	4,000	4,000	24" x 48"	48" x 84"
5ABS60	5"	6,000	6 ½"	4,000	4,000	24" x 48"	48" x 72"
7ABS20	7"	2,000	6 ½"	2,000	2,000	24" x 48"	48" x 96"
7ABS45	7"	4,500	6 ½"	4,000	4,000	24" x 48"	48" x 84"
7ABS60	7"	6,000	7 ½"	4,000	4,000	24" x 48"	48" x 72"
10ABS20	10"	2,000	7 ½"	2,000	2,000	24" x 48"	48" x 96"
10ABS40	10"	4,000	7 ½"	4,000	4,000	24" x 48"	48" x 84"
10ABS45	10"	4,000	12 ½"	4,000	4,000	24" x 48"	48" x 84"
11ABS40	11"	4,000	7 ½"	3,000	3,000	24" x 48"	48" x 72"
12ABS20	12"	2,000	12 ½"	2,000	2,000	24" x 48"	48" x 96"
12ABS30	12"	3,000	12 ½"	3,000	3,000	24" x 48"	48" x 84"
12ABS45	12"	4,500	12 ½"	4,000	4,000	24" x 48"	48" x 84"
15ABS20	15"	2,000	12 ½"	2,000	2,000	24" x 48"	48" x 96"
15ABS30	15"	3,000	12 ½"	3,000	3,000	24" x 48"	48" x 84"

LOADING

The scissors lifts have the load capacity rating stamped on a metal plate attached on one side of the lift. This figure is a net capacity rating for a lift furnished with the standard platform. In the event that gravity-roll sections, special tops, etc., are installed on the lift after leaving the plant, deduct the weight of these from the load rating to obtain the net capacity. Damage may result if the lifts are overloaded beyond the established capacity

UNBALANCED LOADING

The stabilization provided is basically for balanced loads. Due to the fact that the lift is designed to operate without having to be lagged to the floor, special attachments that extend beyond the length and/or width dimensions of the platform should be avoided. This will prevent unintentional tipping of the lift that could lead to damage of the equipment or personal injury.

- 
1. Remove all load from the platform. Never block the lift when loaded, only when empty.
 2. Raise the lift platform sufficiently to install the maintenance block between both the lower leg rollers and base frame.
 3. Begin lowering the platform by activating the “DOWN” valve until the maintenance bar is captured between the lower leg rollers and base frame. Continue activating the “DOWN” valve five to ten seconds to relieve the air pressure in the air bag.
 4. Always shut off the main air supply, when blocked, to prevent someone from turning it on.
 5. To remove the maintenance bar, raise the platform by activating the “UP” valve to provide sufficient clearance for the removal of the maintenance bar.



WARNING!

To avoid personal injury, NEVER go under the lift platform until the load is removed and the scissors mechanism is securely blocked in the open position.

INSTALLATION INSTRUCTIONS

1. Make sure installation area is clean before starting.
2. If the permanent air supply work is not complete, some means of temporary lines with an on-off device for the air supply should be set up for testing purposes.
3. Place the lift in the installation area.



CAUTION!

When moving the lift do not attempt to pick it up by the platform; it is hinged and could be damaged. Pick up from under the base frame ONLY.

4. Make temporary air connections. Raise the lift to the top of its travel and make positioning adjustments. Check for the proper height. If needed, shim to the desired height.



WARNING!

To avoid personal injury, NEVER go under the lift platform until the load is removed and the scissors mechanism is securely blocked in the open position.

5. If the lift is to be lagged to the floor, the base frame of the lift has pre-drilled holes for lagging the lift. Mark the holes, drill, and install with anchors.
6. Make permanent air connections and operate the lift through a few cycles.

CLEAN UP

1. Clean up any debris from the area. A clean installation makes a good impression and creates a much safer environment!
2. Touch-up paint is available from *Autoquip* for repair of damaged paint surfaces.

INSTALLATION INSTRUCTIONS



WARNING!

All DANGER, WARNING, and CAUTION labels and informational decals and plates must be intact and in place on the lift. Contact an *Autoquip* representative if labels are missing or damaged. See the “Label Identification” section.

OPERATING INSTRUCTIONS

1. Scissors lifts have a maximum lifting capacity (see “Specifications” section). The safety relief air valve has been factory set to open at a point slightly above the rated load and allows the air to bypass into the atmosphere. Lowering loads exceeding the rated capacity of the lift may result in excessive wear and damage to the lift.
2. This type of lift is designed primarily for in-plant applications and can be furnished with constant pressure foot valve or hand valve controls. Actuating the "UP" valve will cause air to enter the air bag and the lift will rise.
3. When the desired height or upward travel of the platform is attained, removing the operators' foot or hand from the valve deactivates the “UP” valve. The air stops flowing into the bag and the upward movement will stop.
4. To lower the lift, activate the "DOWN" portion of the control valve, which allows air to exhaust to the atmosphere. Opening the down control valve allows the air in the air bag to flow through the down valve at a controlled rate and exhaust to the atmosphere.
5. When the desired height or downward travel of the platform is attained, removing the operator's foot or hand from the valve deactivates the “DOWN” valve. The air stops flowing from the bag and the downward movement will stop.



CAUTION!

Do not continue to activate the "UP" valve if the lift is not raising or if it has reached the fully raised position. To do so may result in permanent damage to the lift.

ROUTINE MAINTENANCE

Normally scissors lifts will require very little maintenance. However, a routine maintenance program could prevent costly replacement of parts and/or downtime.



WARNING!

To avoid personal injury, NEVER go under the lift platform or perform any maintenance on the lift until the load is removed and the scissors mechanism is securely blocked in the open position. See the "Lift Blocking Instructions" section.

Monthly inspection should consist of the following:

1. Check for visible air leaks; correct as necessary.
2. Check any unusual noise when it occurs. Determine the source and correct as necessary.
3. Check the snap rings at all rollers, if not in place, and/or secure, replace or repair immediately.
4. Check all rollers for signs of wear. Replace as necessary.
5. Do not grease roller or axles; they have lifetime-lubricated bearings.
6. The lift has a safety relief valve, which is factory pre-set. The relief valve should not be adjusted **for any reason** as it could cause the lift to fall uncontrollably.

GENERAL MAINTENANCE

AIR BAG REMOVAL AND REPLACEMENT



WARNING!

To avoid personal injury, **NEVER** go under the lift platform until the load is removed and the scissors mechanism is securely blocked in the open position. See the "Lift Blocking Instructions" section.

1. Raise the lift from the clevis end. If the lift cannot be raised with the air supply, place a hook under the clevis end of the platform and raise it with a chain fall or other similar means.
2. Disconnect the main air supply.
3. Block the lift open (see "Lift Blocking Instructions").
4. Tilt the roller end of the platform all the way back.
5. Remove the air line and bolts from the old air bag. Unbolt the air bag from the base assembly.
6. Install the new air bag. Bolt the bottom first, then manually extend the air bag and bolt the top. NOTE: The bolts must be tightened such that the four bolts opposite each other are tightened in sequence (example: first north, then south, then east, then west).
7. Connect the air line to the air bag.
8. Connect the main air supply.
9. Return the platform to its original position.
10. Raise the lift slightly and remove the maintenance lock.

NOTE: This job should require one to two hours of time, depending on the experience of the service technician.

GENERAL MAINTENANCE

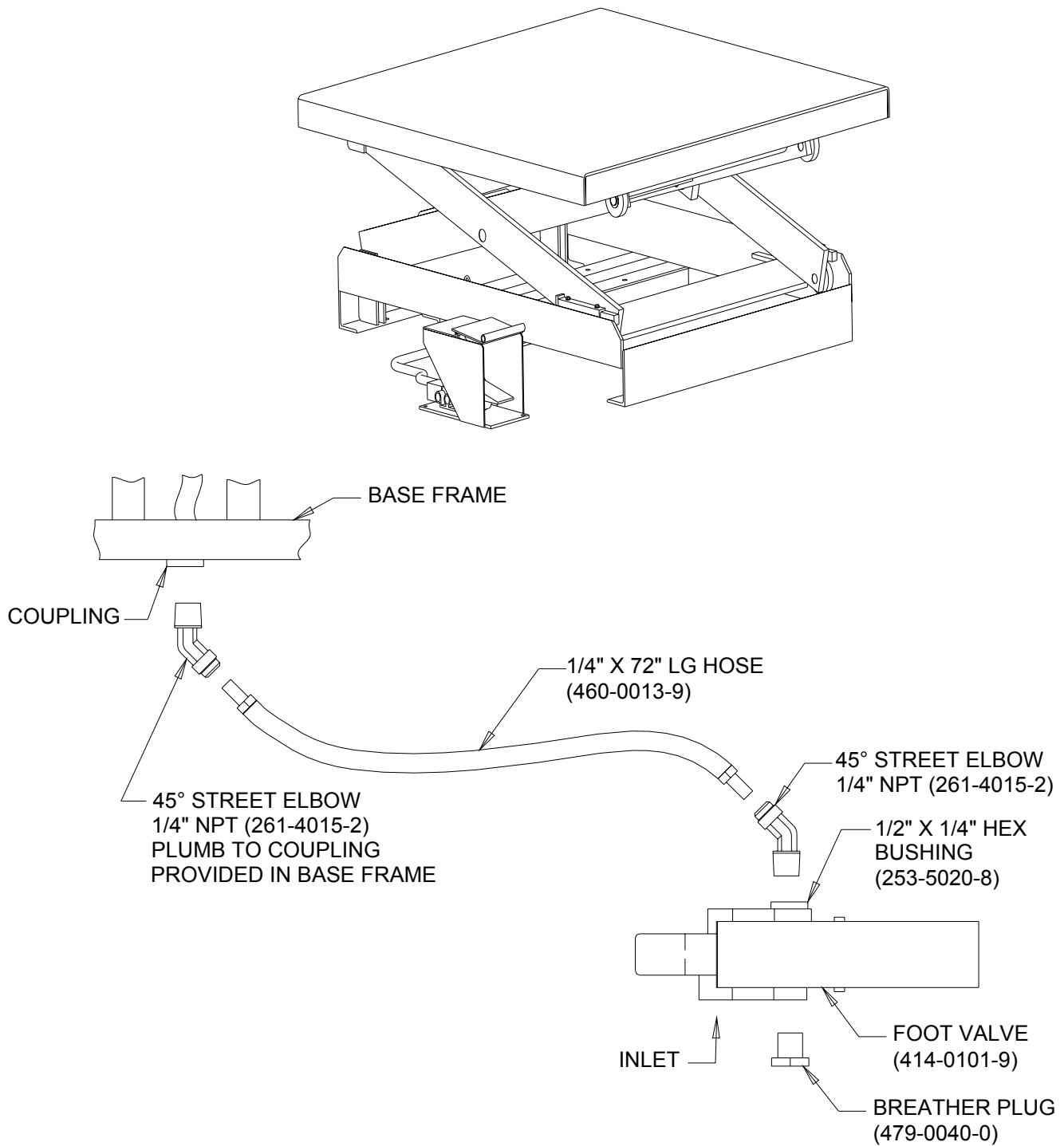
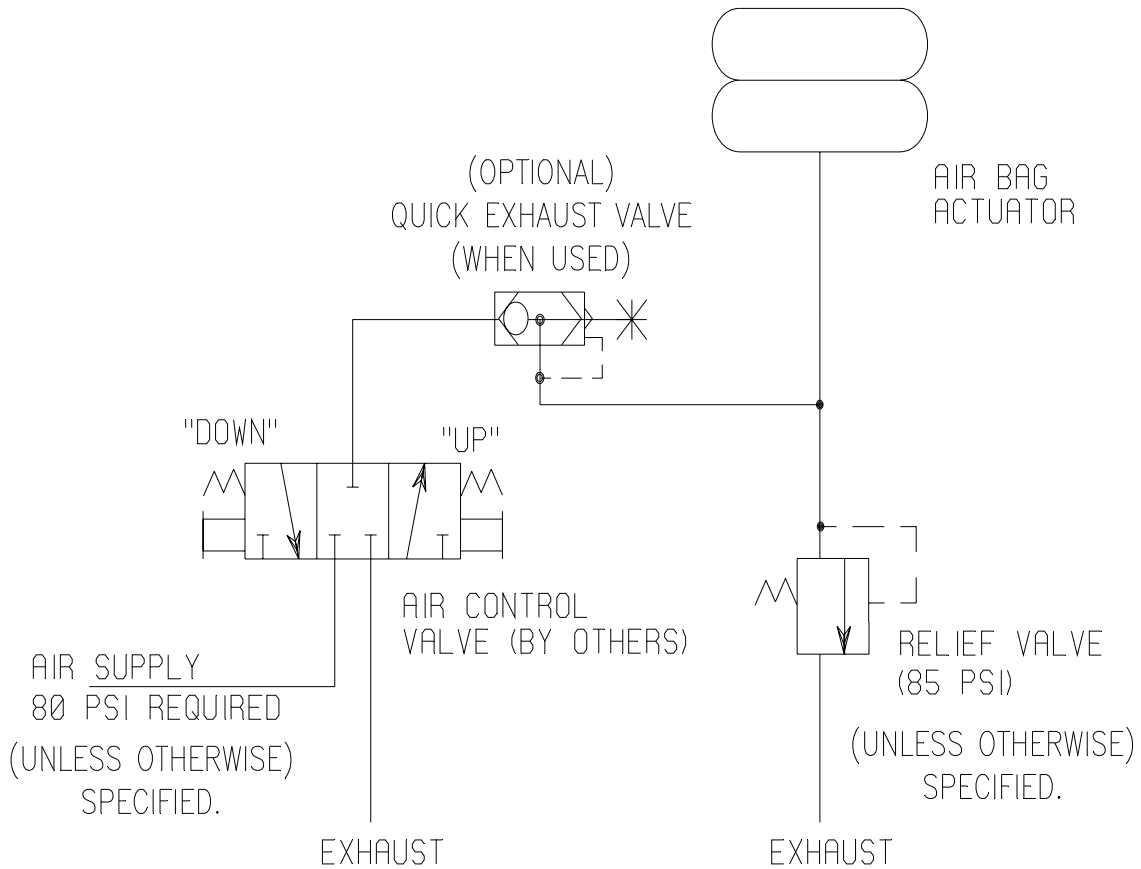

Figure 8 Foot Valve Connections

GENERAL MAINTENANCE



PNEUMATIC SCHEMATIC
AIR-BAG LIFT

Figure 9 Pneumatic Schematic

REPLACEMENT PARTS LIST

Part Number	Description
20022851	Clevis Pin Bushing, 18DU12
20023966	Main Axle Bushing, 24DU24
40730525	Air Bag #7145, Firestone
41401019	Foot Valve
45400082	Retainer Ring, 1 1/8"
45400108	Retainer Ring, 1 1/2"
52500154	Upper & Lower Clevis Pin, 1 1/8" x 1 3/4"
52500204	Main Axle Pin, 1 1/2" x 3 5/8" long
52500253	Upper and Lower Leg Roller Pin, 1 1/8" x 1 3/4"
52600269	Upper and Lower Leg Roller, 1 1/8 ID x 3" OD x 3/4" thick

TROUBLESHOOTING ANALYSIS



WARNING!

To avoid personal injury, **NEVER** go under the lift platform until the load is removed and the scissors mechanism is securely blocked in the open position. See the "Lift Blocking Instructions" section.

PROBLEM	POSSIBLE CAUSE AND SOLUTION
Lift does not raise	<ul style="list-style-type: none">• The load may exceed the rating for the specific line pressure.• There may not be enough, or any, line pressure. Check the supply pressure with a gauge and ensure it provides the minimum pressures required.• Make sure the air supply line is connected to the correct port on the hand or foot control valve. It is marked "Inlet".• It may be that an obstruction was introduced into the system during installation. Check for obstructions at the inlet of the control valve, in the connecting hose to the lift, and at the restrictor in the bottom of the air bag.
Lift drifts down slowly during non-operation.	<ul style="list-style-type: none">• Make sure all of the connections are tight and that no leaks are occurring in the system.
Lift seems bouncy during operation.	<ul style="list-style-type: none">• This is normal for large volume (air bag) air-powered systems due to the compressible nature of air, especially at raised elevations between fully lowered and fully raised positions.

TROUBLESHOOTING ANALYSIS

PROBLEM	POSSIBLE CAUSE AND SOLUTION
Lift raises very slowly.	<ul style="list-style-type: none"> • The primary cause of slow actuation in air-powered systems is a lack of air volume (cubic feet per minute (CFM) to the lift. Determine the air volume of the air supply system/ compressor. For the lift to operate at reasonable speeds (10-15 seconds raising time), the lift needs to have a minimum of five CFM. • Make sure all connections are tight and that no leaks are occurring in the system. • It may be that an obstruction was introduced into the system during installation. Check for obstructions at the inlet of the control valve, in the connecting hose to the lift, and at the restrictor in the bottom of the air bag.
Lift does not lower, or lowers very slowly.	<ul style="list-style-type: none"> • Make sure the inlet, outlet, and exhaust lines are connected to the correct ports on the hand or foot control valve. • It may be that an obstruction was introduced into the system during installation. Check for obstructions at the outlet of the control valve, in the exhaust line from the control valve (if applicable), or in the connecting hose to the lift. • Make sure the if the lift was raised and blocked open for maintenance that the flip-over maintenance locks were removed from the path of the lift rollers and placed back in the "home" position.