

# FS-612 Finisher

# INSTALLATION MANUAL **corretto**

Applied Machine: C8000/C7000/C7000P/C6000/C70hc  
 COLOR PRESS: 80/(71ppm/71ppm)/(70ppm/70ppm)/(60ppm/60ppm)  
 Product Code: A1RF/A1DU/A204/A1DV/A205





**Note:**





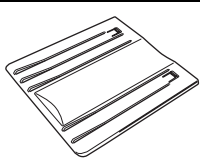

Take the same procedures, though the machine photographs are different from the ones illustrated in the procedures.

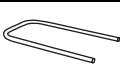
## I. Precaution

1. Choose a horizontal and stable floor for installing the machine.
2. Lifting the machine in an awkward position or transporting it in a poorly balanced position could result in personal injury. When transporting the machine, assign an adequate number of persons to the job and ensure that each person can take a good position of not being excessively loaded. (mass: approx. 65 kg)

## II. Accessory parts

No.	Name	Shape	Q'ty
1.	Installation plate/lower	 A1TVIXC001CA	1
2.	Installation plate/upper	 A1TVIXC002CA	1
3.	Paper exit up-down tray	 A1TVIXC003CA	1
4.	Paper exit tray /1	 15JMIXC004SA	1
5.	Paper exit tray/ lower	 15JMIXC005SA	1
6.	Stopper block	 15JMIXC006SA	1
7.	Guide axis	 15JMIXC007SA	2

No.	Name	Shape	Q'ty
8.	Rear end stopper	 15JMIXC008SA	1
9.	Knob screw		2
10.	TP screw M4x6		4
11.	TP screw M4x18		2
12.	Truss screw M4x8		2
13.	Installation manual		1

- FS-612 + RU-508 + C8000.....pages 3 to 4
- FS-612 + C7000/C7000PC/6000/C70hc .....pages 4 to 5
- FS-612 + RU-509 + C7000/C7000P/C6000/C70hc .....pages 6
- Common operations after installing FS-612 ..... Page 7 to 10

## III. Confirmation before installation

**Note:**

1. When transporting the Finisher, be sure to move it in the direction illustrated below so as not to deform the casters on the paper exit tray side.

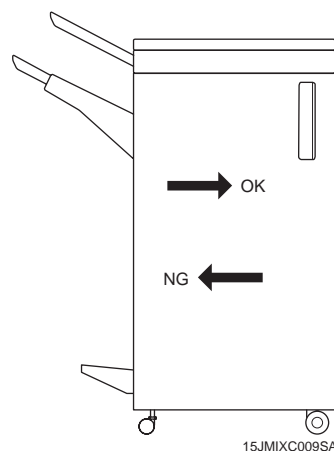

2. When installing optional Post Inserter/Punch kit to the Finisher, be sure to install it beforehand, then install the finisher to the machine.

## IV. Procedure before installation

1. Visually inspect the Finisher.
2. Remove the locking tapes and the locking protection materials from the front door and the left side of the Finisher.

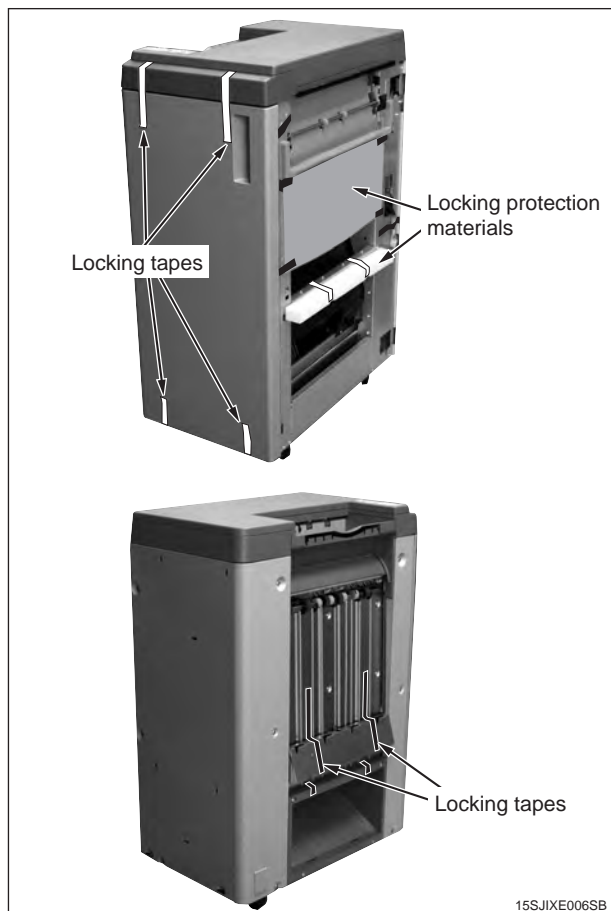

3. Remove the locking tapes from each guide plates.
4. Remove the stacker locking materials.

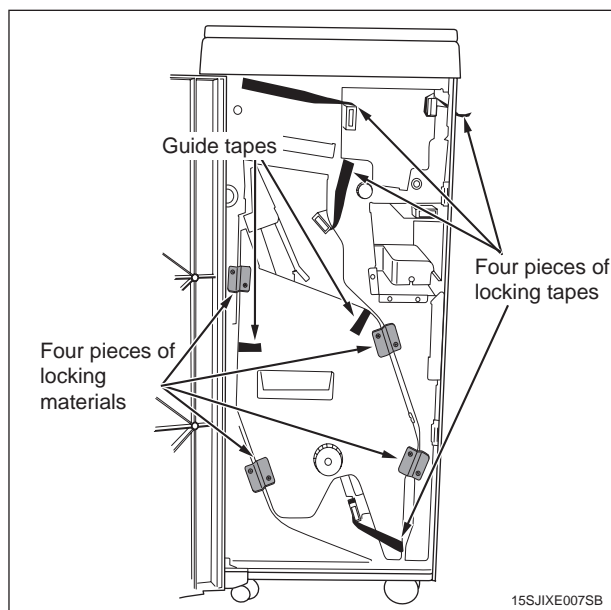

5. Pull out the stacker, then remove the locking tape. Remove the guide tape from inside the stacker (on the right side), and remove the locking material. (1 screw)

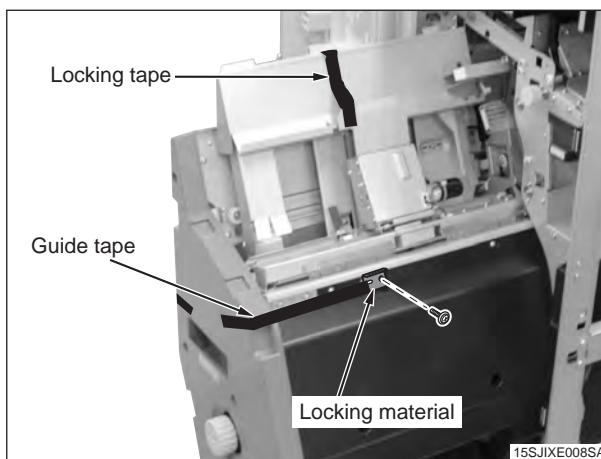

6. Remove the guide tape from inside the stacker (on the left side), and remove the locking material (1 screw) and the locking tape (1 place) from the staple cartridge (front).

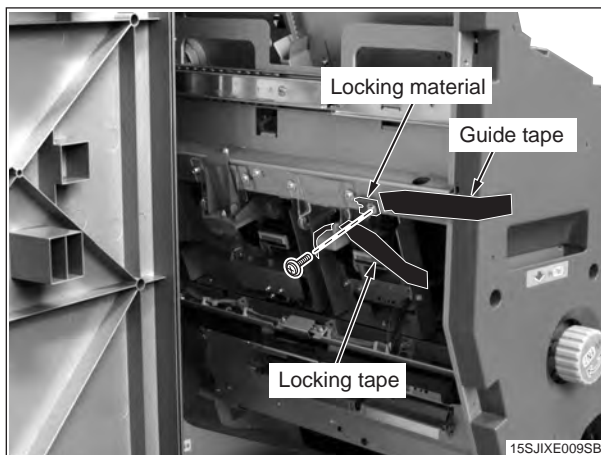

7. Remove locking materials (2 places) from the staple cartridge (back).

### Note:

Remove the screw ① first.

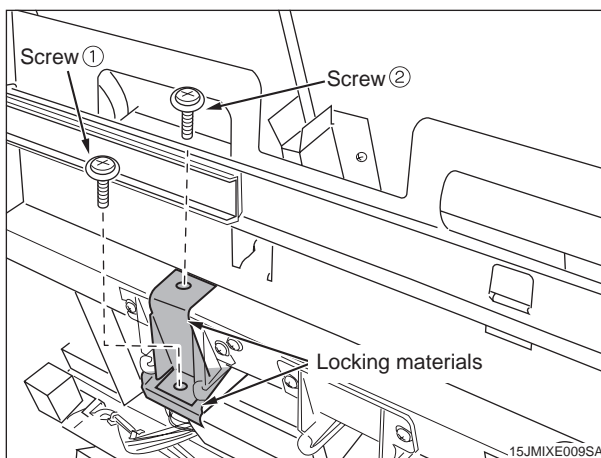

8. When using paper in inch size (LT) or 16K.
  - (1) Loosen the three-fold stopper screw.
  - (2) Align the three-fold stopper to the mark for the LT paper size on the right side.

**Note:**

For 16K paper size, align the sheet-metal level difference (located in the left) to the mark for the 16K paper size.

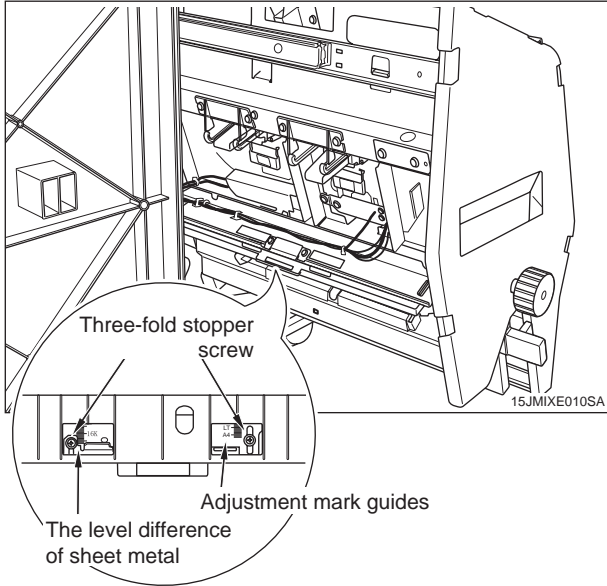

## V. Installation procedure

### Installation procedure for [FS-612 + RU-508 + C8000]

1. Turn the Sub and Main power switches OFF, and unplug the power cord from the outlet.
2. Install the machine installation plate (lower) on the lower left side of RU-508. (TP screw M4x6: 2 pcs.)

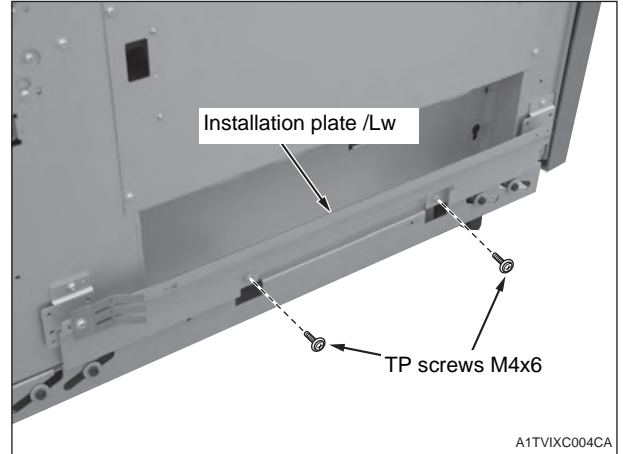

3. Install the machine installation plate (upper) on the upper left side of the RU-508. (TP screw M4x6: 2 pcs.)

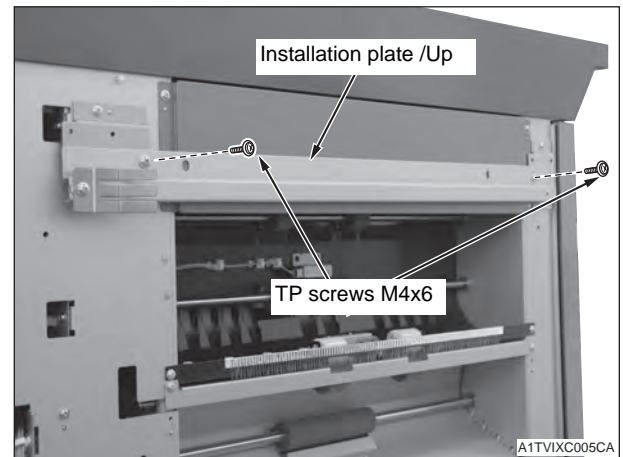

4. Connect the four connectors of the Finisher to the connectors on the rear left side cover of the RU-508.

**Note:**

Do not connect to the 8-pin connector.

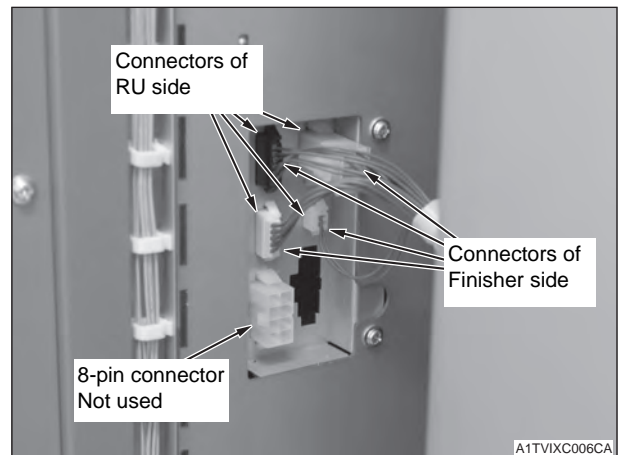

5. Install the Finisher on the RU-508.

- (1) Fit the hooks on the RU-508 installation plates (upper and lower) into the upper and lower holes on the Finisher as illustrated below, then lock them by pushing the Finisher to the back.

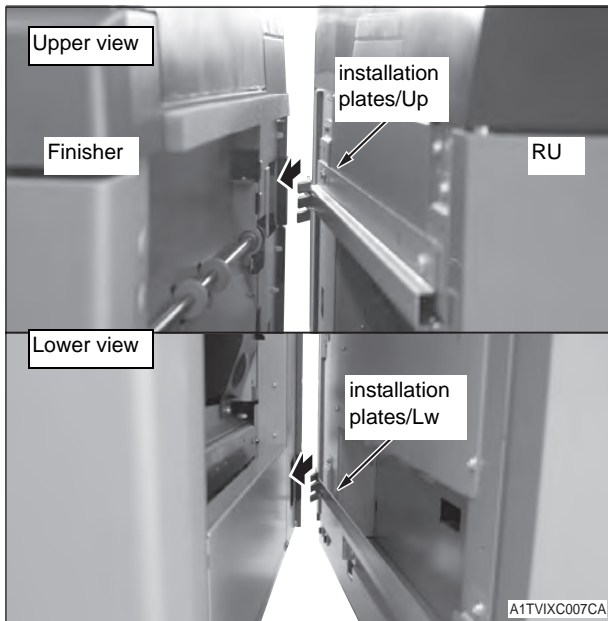

**Note:**

If the gap between Finisher and RU-508 is not equal from the top through the bottom, adjust it by the height of the front and rear casters on the paper exit side of the Finisher.

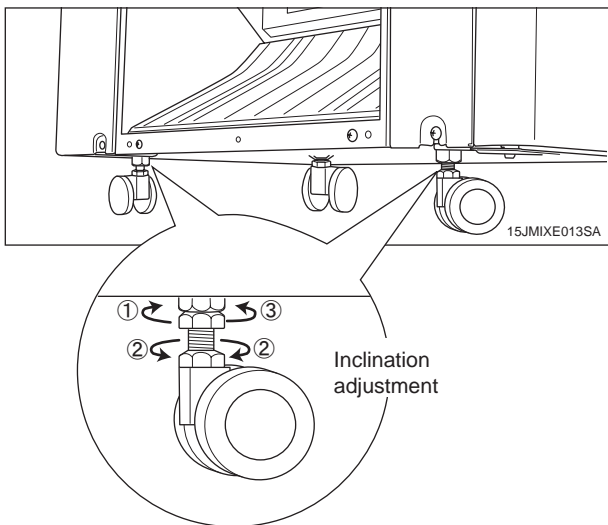

- (2) Fix the Finisher to the RU-508. (Knob screw: 2 pcs.)

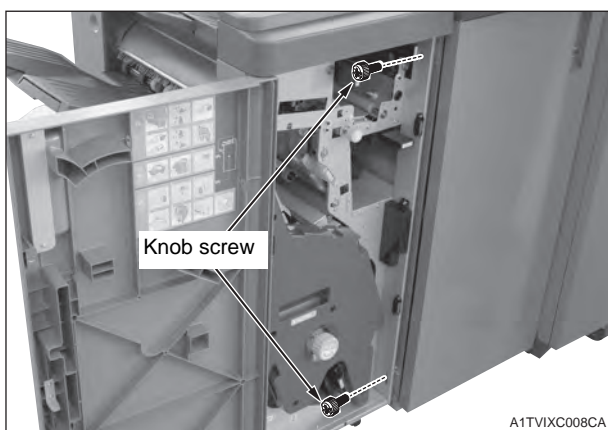

**Installation procedure for [FS-612 + C7000/C7000P/C6000/C70hc]**

1. Turn the Sub and Main power switches OFF, and unplug the power cord from the outlet.
2. Remove the two caps on the left side cover of the machine.
3. Remove the connector cover on the left side cover of the machine. (1 screw)

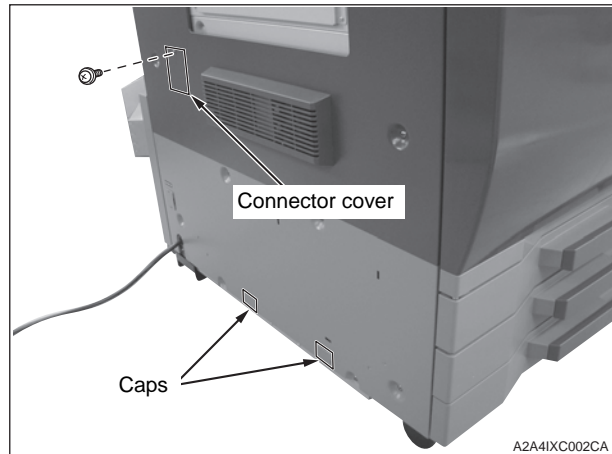

4. Install the machine installation plate (lower) on the lower left side of machine. (TP screw M4x6: 2 pcs.)

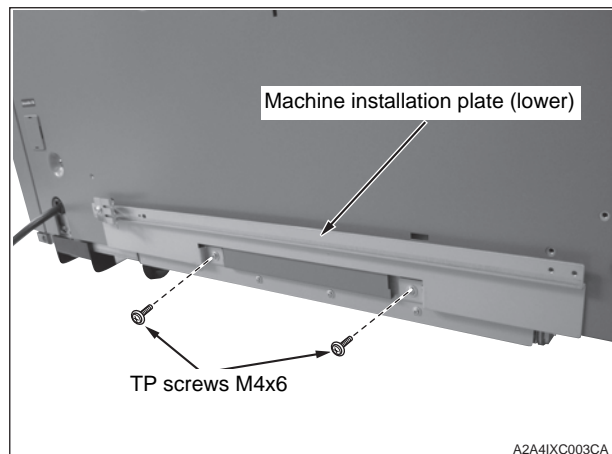

5. Install the machine installation plate (upper) on the upper left side of the machine. (TP screw M4x18: 2 pcs.)

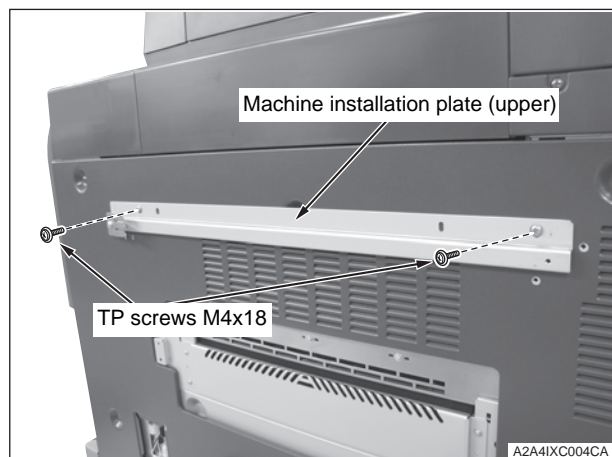



6. Remove the rear cover of the FS-612. (6 screws)

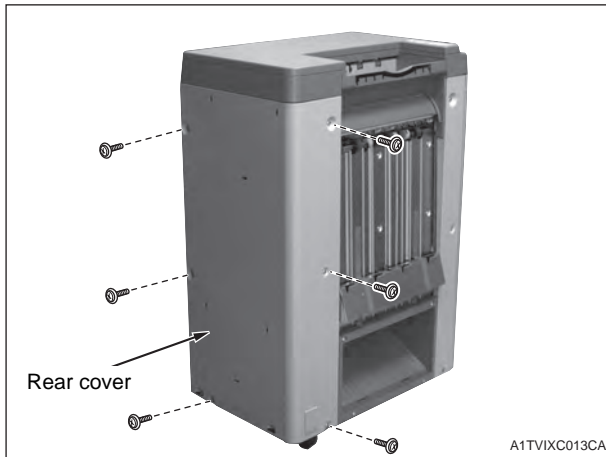

7. Remove the CN-3 connector from the control board as shown in the figure below.  
 8. Remove the short connector from the clamp.

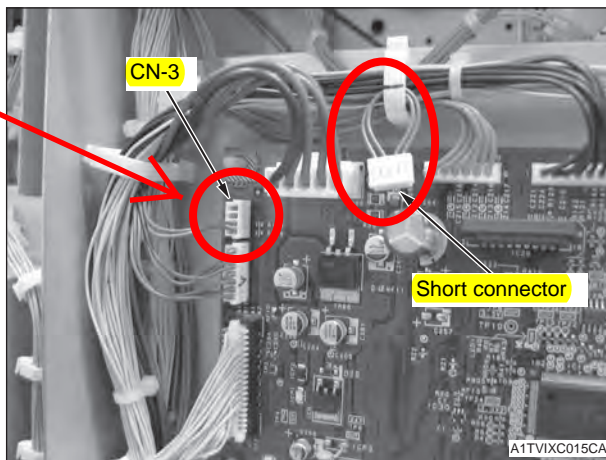

9. Connect the short connector to the CN-3.  
**Note:**  
 Unless the short connector is connected, the ISW cannot be performed.

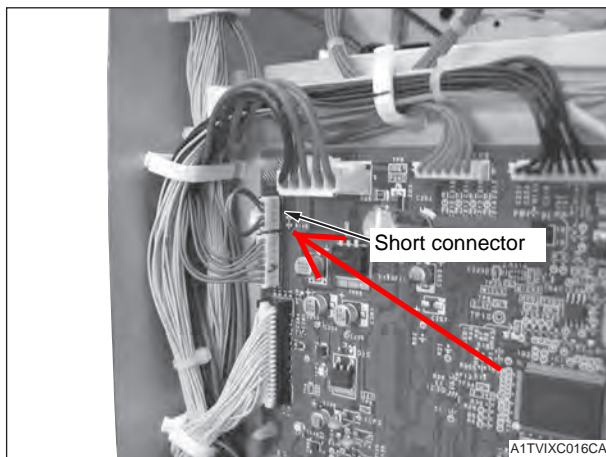

10. Reinstall the rear cover of the FS-612. (6 screws)

11. Connect the three connectors of the Finisher to the connectors on the rear left side cover of the machine. (1 connector is not used)

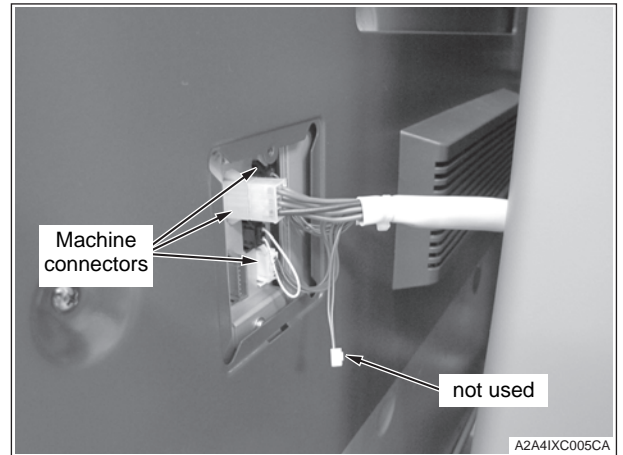

12. Install the Finisher on the machine.  
 (1) Fit the hooks on the machine installation plates (upper and lower) into the upper and lower holes on the Finisher as illustrated below, then lock them by pushing the Finisher to the back.

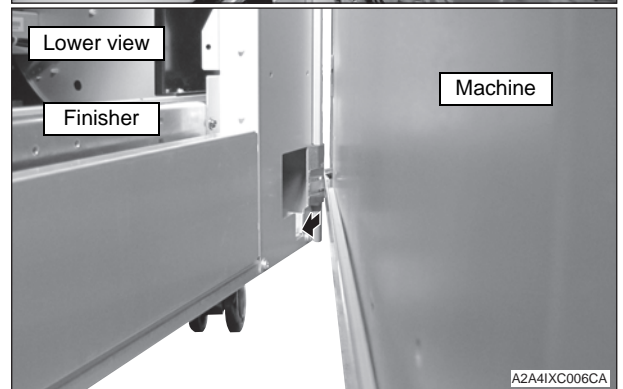
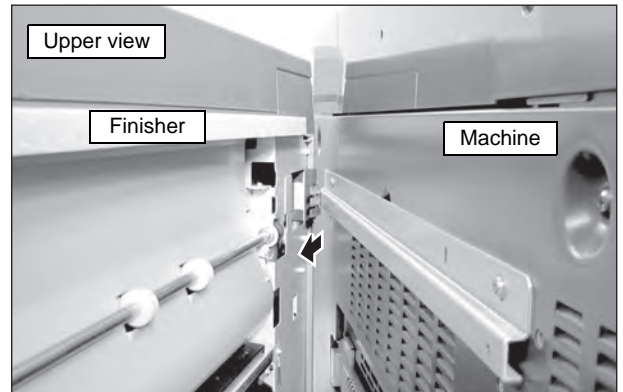

- (2) Fix the Finisher to the machine. (Knob screw: 2 pcs.)

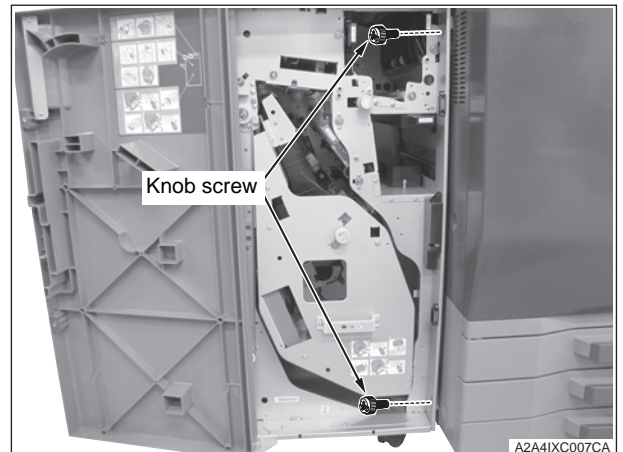

**Installation procedure for  
[FS-612 + RU-509 + C7000/C7000P/C6000/C70hc]**

1. Turn the Sub and Main power switches OFF, and unplug the power cord from the outlet.
2. Install the machine installation plate (lower) on the lower left side of RU-509. (TP screw M4x6: 2 pcs.)

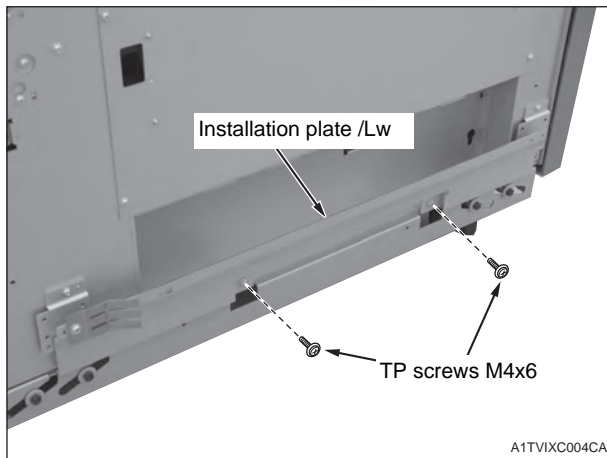

3. Install the machine installation plate (upper) on the upper left side of the RU-509. (TP screw M4x6: 2 pcs.)

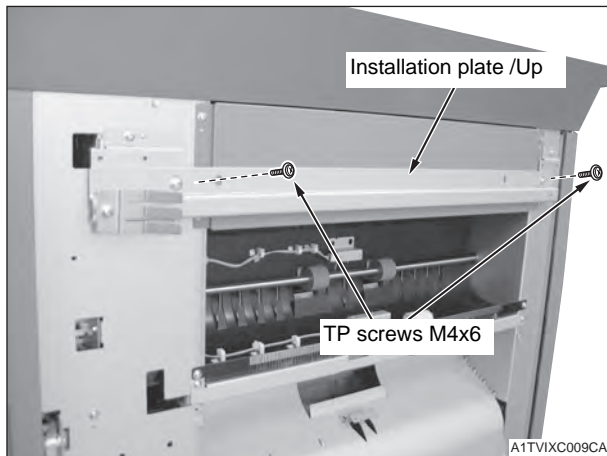

4. Connect the four connectors of the Finisher to the connectors on the rear left side cover of the RU-509.

**Note:**

Do not connect to the 8-pin connector.

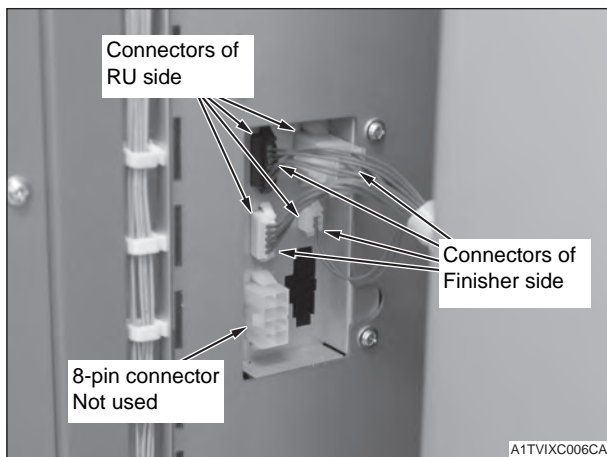

5. Install the Finisher on the RU-509.

- (1) Fit the hooks on the RU-509 installation plates (upper and lower) into the upper and lower holes on the Finisher as illustrated below, then lock them by pushing the Finisher to the back.

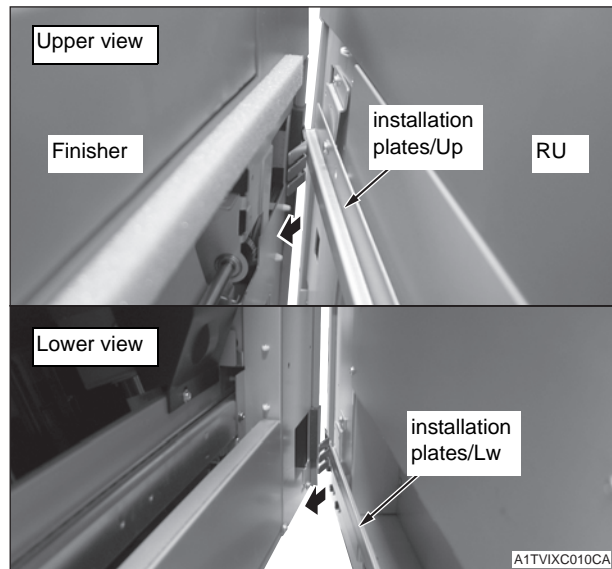

**Note:**

If the gap between Finisher and RU-509 is not equal from the top through the bottom, adjust it by the height of the front and rear casters on the paper exit side of the Finisher.

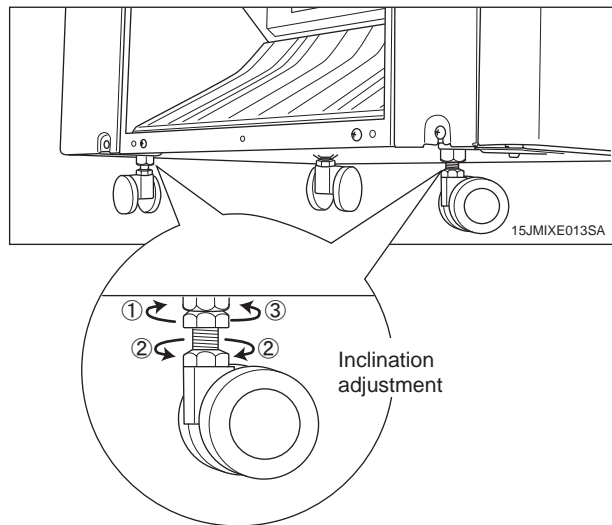

- (2) Fix the Finisher to the RU-509. (Knob screw: 2 pcs.)

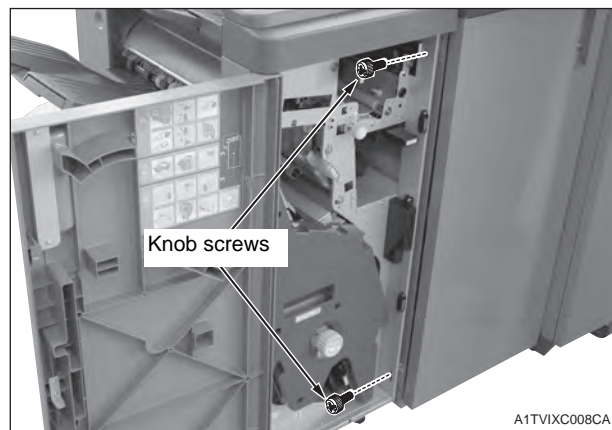

## VI. Common operations

1. Insert paper exit tray/1 into the sub tray paper exit slot on the Finisher.

**Note:**

When installing paper exit tray/1, push the tray all the way in until you hear a click.

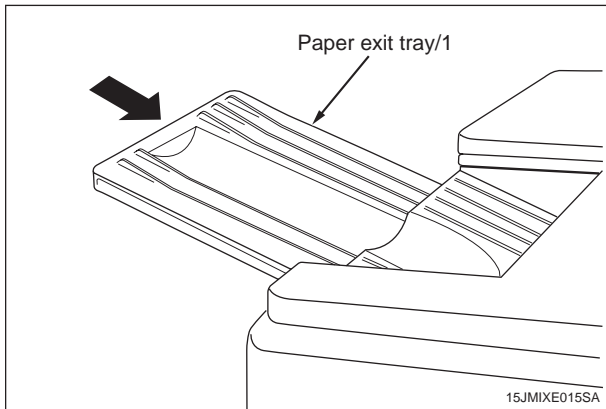

2. Install the paper exit tray/lower on the lower up down portion on the Finisher.

- (1) Remove the 2 screws from the lower up-down portion.

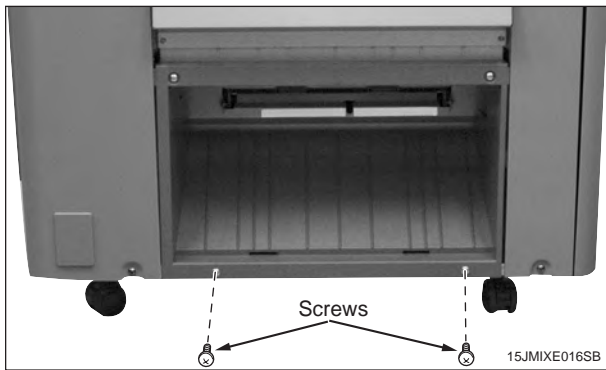

- (2) Insert the stopper block into the paper exit tray / lower.
- (3) Use the screws from the lower up-down portion to install the paper exit tray / lower.
- (4) Insert the Guide axes on the paper exit tray / lower.
- (5) Insert the rear end stopper to the position of the paper size to be used.

**Note:**

When installing the paper exit tray/lower, adjust the height of the paper exit tray/lower using the stopper block and secure the tray.

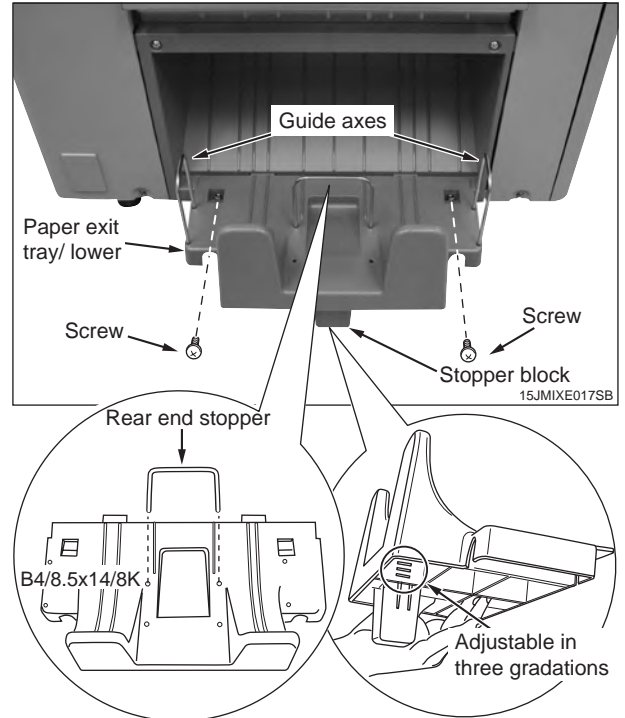

3. Install the paper exit up-down tray on the up down portion on the Finisher.  
(Truss screw M4x8: 2 pcs.)

**Note:**

When installing the paper exit up-down tray, hook the paper exit up-down tray to the four auxiliary metal hooks and secure the tray.

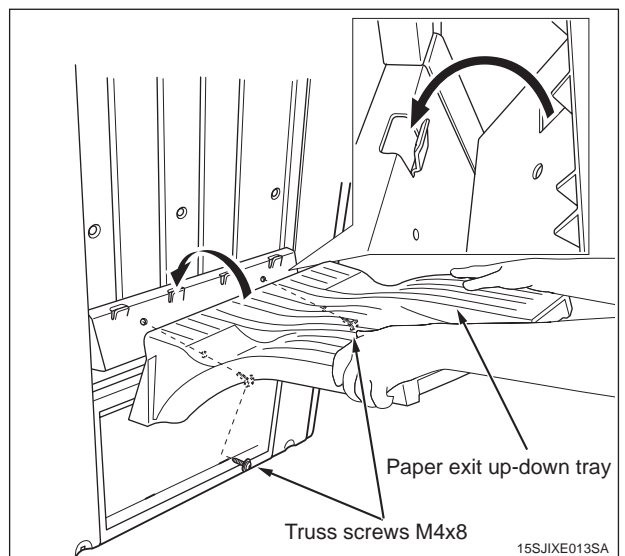



## VII. Importing FS Adjustment Data

Import the factory adjustment data of the FS-612 to the machine memory.

	Step
1.	Plug the power cord into the outlet and turn ON the Main power switch.
2.	Enter Service mode. <b>Note:</b> Refer to procedures in the Service Manual to enter into the Service Mode.
3.	On the Service mode menu screen, touch "Finisher Adjustment".
4.	[Finisher Adjustment Menu screen] Touch "Recall Standard Data".
5.	Touch "Factory Initial Data" on the recall standard data screen and touch "Yes" .
6.	Touch "Return" to return to the [Finisher Adjustment Menu] screen.

## VIII. Confirmation of operation

- Place the original in each mode setting in the ADF.
- Execute printing in Finisher mode to check the condition of half-folding, center stapling, three folding, and flat stapling.

### Note:

If each mode setting is not appropriate value, execute the adjustment as following procedure.

### a. Half-Fold Position adjustment

#### [Adjustment]

	Step
1.	[Finisher Adjustment menu screen] Touch "Half-Fold Stopper Adj.".
2.	Check the amount of gap on the rear edge of the folded sample copy. <ul style="list-style-type: none"> <li>Touch "Print Mode" to go to the copy screen.</li> <li>Make a folded sample copy of the size to be adjusted.</li> </ul>
3.	Touch "Exit PrintMode" to return to the [Half Fold Stopper Adj.] screen.
4.	Select the adjustment object size.
5.	Use the numerical keys on the screen to enter adjusting values (appropriate values), and touch "Set". (Setting range: -128 to +127, 1 step=0.1mm)
6.	Make another sample copy.
7.	Repeat steps 2 to 7 until the Half-Fold position is appropriate.
8.	Repeat the same operation about other sizes.
9.	Touch "Return" to return to the [Finisher Adjustment Menu] screen.

### Standard value

- \* For each paper size, the fold slippage should be within 1 mm.

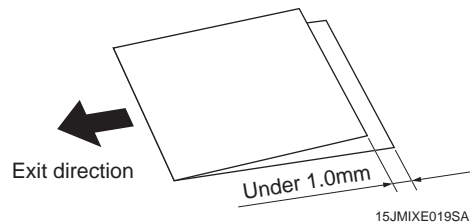

### b. Saddle Stitcher Stopper adjustment

If the copies are not stapled at the position adjusted in step a, perform the following adjustment.

#### [Adjustment]

	Step
1.	[Finisher Adjustment menu screen] Touch "Saddle Stitcher Stopper".
2.	Check the amount of gap on the rear edge of the saddle-stitched sample copy. <ul style="list-style-type: none"> <li>Touch "Print Mode" to go to the copy screen.</li> <li>Make a saddle-stitched sample copy of the size to be adjusted.</li> </ul>
3.	Touch "Exit PrintMode" to return to the [Fold & Staple Stopper adjustment] screen.
4.	Select the size to be adjusted.
5.	Use the numerical keys on the screen to enter adjusting values (appropriate values), and touch "Set". (Setting range: -128 to +127, 1 step=0.1mm)
6.	Make another sample copy.
7.	Repeat steps 2 to 7 until the Center Staple position is appropriate.
8.	Repeat the same operation about other sizes.
9.	Touch "Return" to return to the [Finisher Adjustment Menu] screen.

### Standard value

- \* For each paper size, the slippage between fold and staple should be within 1 mm.



### c. Tri-Fold Position adjustment

A4S and 8.5 x 11S and 16KS sizes

#### [Software adjustment]

First folding position adjustment (Standard value a)

Step	
1.	[Finisher Adjustment menu screen] Touch "Tri-Fold Adjustment".
2.	Check the amount of gap on the rear edge of the saddle-stitched sample copy. <ul style="list-style-type: none"> <li>• Touch "Print Mode" to go to the copy screen.</li> <li>• Make a tri-folded sample copy of the size to be adjusted.</li> </ul>
3.	Touch "Exit PrintMode" to return to the [Tri-Fold Adjustment] screen.
4.	Select the size to be adjusted.
5.	Use the numerical keys on the screen to enter adjusting values (appropriate values), and touch "Set". (Setting range: -128 to +127, 1 step=0.1mm)
6.	Make another sample copy.
7.	Repeat steps 2 to 7 until the first folding position a is appropriate.
8.	Repeat the same operation about other sizes.
9.	Touch "Return" to return to the [Finisher Adjustment Menu] screen.

#### [Mechanical adjustment]

Second folding position adjustment (Standard value c)

When adjustment of the first folding position is finished, check the second folding position. If it is not appropriate, adjust the location of three-fold stopper in the stacker.

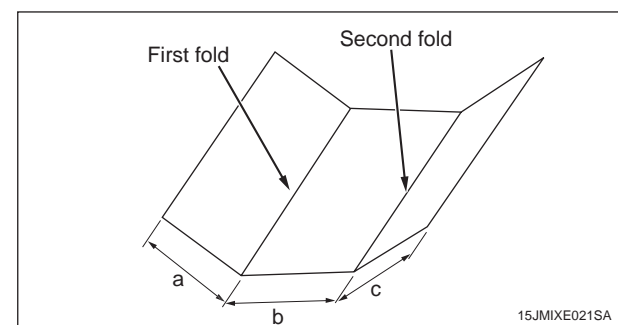
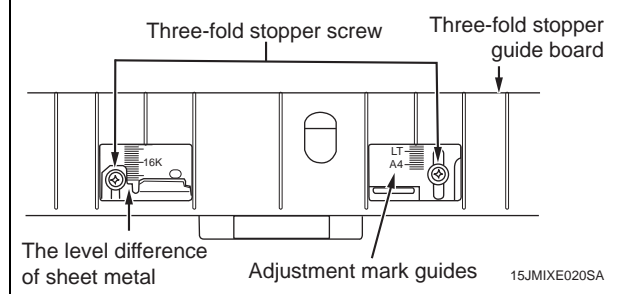

standard values

Unit: mm

Section	Item	Normal value			Standard
		A4S	8.5x11S	16KS	
Fold position	a	95	89.4	88	±2
	b	101	95	91	
	c	101	95	91	

### d. 2 Position Staple adjustment (Staple / Fold & Staple)

This is to be adjusted only after all the other adjustments have been completed.

1. 2 position staple pitch

#### [Adjustment]

Step	
1.	[2 position Staple Pitch screen] Touch "Staple".
2.	Touch "Print Mode", make a stapled sample copy on the copy screen, and check the staple pitch.
3.	If the staple pitch is not appropriate, touch "Exit PrintMode" to return to the adjustment screen, use the numerical keys on the screen to enter adjusting values (appropriate values), and touch "Set". (Setting range: 128 to 160, 1 Step=1mm)
4.	Make another sample copy.
5.	Repeat steps 3 to 5 until the staple pitch is appropriate.

Adjustment values

\* Staple pitch A can be adjusted between 128 mm and 160 mm.

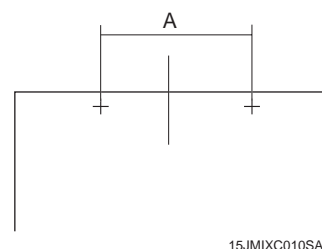

## 2. Fold and staple pitch

### [Adjustment]

	Step
1.	[2 Pos. Staple Pitch Adjustment screen] Touch "Fold & Staple".
2.	Touch "Print Mode", make a stapled and folded sample copy on the copy screen, and check the staple pitch.
3.	If the staple pitch is not appropriate, touch "Exit PrintMode" to return to the adjustment screen, use the numerical keys on the screen to enter adjusting values (appropriate values), and touch "Set". (Setting range: 128 to 160, 1 step=1mm)
4.	Repeat steps 2 to 4 until the staple pitch is appropriate.
5.	Make another sample copy.
6.	Touch "Return" key and "Close" key.

### Adjustment values

- \* Staple pitch A can be adjusted between 128 mm and 160 mm.

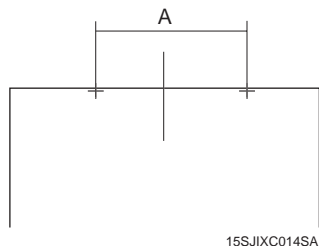

## IX. Adjustment Data Backup

If the FS-612 adjustment data is changed, back up the main body finisher data to the FS-612 memory.

	Step
1.	On the Service mode menu screen, touch "State Confirmation".
2.	Touch "I/O Check Mode".
3.	Enter "9" and "0" using the quantity setting buttons. Make sure that <90-00> appears on the message display.
4.	Press the [Start] key. Make sure that <OUT:FIN> appears on the message display after the adjustment.
5.	Touch the "Return" key, then touch the "Exit" key.

## X. Serial Number Registration

Register the serial number of the FS-612 to the machine memory.

	Step
1.	Plug the power cord into the outlet and turn ON the Main power switch.
2.	Enter Service mode. <b>Note:</b> Refer to procedures in the Service Manual to enter into the Service Mode.
3.	Touch the "System Setting" key.
4.	Touch the "Serial Number Setting" key.
5.	Touch the "Finisher" key to display the serial number setting screen. (Select the installation order key.)
6.	Enter the serial number of the FS-612 and touch the "OK" key. (Use "Shift" to switch between upper case letters and lower case letters.)
7.	Touch the "Return" key, then touch the "Close" key.