

# VALUEGEN<sup>®</sup>

## TECHNICAL MANUAL

### V-525/550/650



## Table of Contents

Preface	3	External Exposure Indication	27
Warranty	3	High Speed Starter Interface	28
Presentation	3	<b>Chapter 4: Setup</b>	<b>29</b>
Notation	3	Overview	29
Applicability	4	Power On Test	29
Safety	4	Blue Watch Dog LED	29
Environment	4	Power On	29
Radiation Warning	4	Pre-Set #s	29
<b>Chapter 1: Specifications</b>	<b>5</b>	X-Ray Tube Selection	33
Ratings	5	mA Station Selection	35
Configuration	8	Filament Standby Number	35
Operator's Console	8	HV Cable Length	36
Modes of Operation	10	Buckys and AEC Selection	37
Manual Mode	10	Maximum kVp	37
APR Mode	11	Rotor Speed	37
HV Tank	15	Low Speed Boost Time	38
<b>Chapter 2: Installation</b>	<b>16</b>	Interlock Selection	38
Site Preparation	16	<b>Chapter 5: Calibration</b>	<b>39</b>
Unpacking	16	kVp Feedback Test	39
Inspection	16	Calibration	40
Mechanical Installation	17	Manual Calibration	43
Interconnection	17	AUTOCAL	43
P1/P2 Cable	17	AEC Density Adjust	44
Interconnecting Cable	18	<b>Chapter 6: Compliance Testing</b>	<b>45</b>
Hand Switch	18	Overview	45
<b>Chapter 3: Interface</b>	<b>19</b>	Configuration	45
Mains	19	Operator's Console	45
Single Phase, 208 VAC ( i-325/425)	19	Standard Operator's Console	46
3 Phase, 208 VAC	19	APR Operator's Console	49
3 Phase, 380 VAC	20	Exposure Factor Tests	51
Buckys	20	kVp/mA	51
V-RAD SYSTEM BUCKY CONNECTIONS	21	Time	53
SIMPLIFIED BUCKY CONNECTIONS	22	Reporting	54
Rotor	24	<b>Chapter 7: Diagnostics</b>	<b>55</b>
External Handswitch/Footswitch	24	Overview	55
Interlocks	26	Error Codes	56
AEC	26	Trouble-Shooting Tips	60
Auxillary Relay	26		
24 VAC Collimator Lamp Power	27		

Copyright© 2007 by GTR®LABS, Inc.

All rights reserved. Contents of this publication may not be reproduced in any form or by any means, electronic or mechanical, including photocopying and recording, or by any information storage or retrieval system without the written permission of:

GTR®LABS, Inc.  
 510 Elk Street  
 Gassaway, WV 26624  
 Telephone: 304-364-2211  
 web: www.gtrllc.com  
 email: gtr@gtrllc.com

**Preface**

**Warranty**

**GTR® LABS**, Inc. warrants that this product will be free from defects in materials and workmanship for a period of five (5) years from the date of installation at the first end user’s site; If any such product proves defective during this warranty period, **GTR®**, at it’s option, either will repair the defective product without charge for parts or shop labor, or will provide a replacement in exchange for the defective product.

This warranty shall apply to all equipment and systems sold by GTR® with the exception of the following:

- X-Ray Tubes
- Image Intensifiers
- TV Camera Tubes

The above items are subject to the manufacturer’s warranty in effect as of the date sold. These warranties vary and are pro-rated. The manufacturer will be the final authority for any warranty claim.

In order to obtain service under this warranty, Customer must notify GTR® of the defect before the expiration of the warranty period and make suitable arrangements for the performance of service. Customer shall be responsible for packaging and shipping the defective product to the service center designated by GTR® with shipping charges prepaid. GTR® shall pay for the return of the product to Customer if the shipment is to a location within the country in which the GTR® designated service center is located. Customer shall be responsible for paying all shipping charges, duties, taxes, and any other charges for products returned to any other locations.

This warranty shall not apply to any defect, failure, or damage caused by improper or inadequate maintenance and care. GTR® shall not be obligated to furnish service under this warranty 1) to repair damage resulting from attempts by personnel other than GTR® representatives to install, repair, or service this product; 2) to repair damage resulting from improper use or connection to incompatible equipment or power source; or 3) to service a product that has been modified or integrated with other products when the effect of such modification or integration increases the time or difficulty of servicing the product.

Further, GTR® LABS, Inc. warrants that the product is in compliance with U.S.A. DHHS regulations which may be in force and effect at the time of shipment of the product.

The following is not covered by the warranty:

General maintenance and simple adjustments mentioned in the manuals delivered with the material.

THIS WARRANTY IS GIVEN BY GTR® WITH RESPECT TO THIS PRODUCT IN LIEU OF ANY OTHER WARRANTIES, EXPRESS OR IMPLIED. GTR® AND IT’S VENDORS DISCLAIM ANY IMPLIED WARRANTIES OF MERCHANTABILITY OR FITNESS FOR A PARTICULAR PURPOSE. GTR®’S RESPONSIBILITY TO REPAIR OR REPLACE DEFECTIVE PRODUCTS IS THE SOLE REMEDY PROVIDED TO THE CUSTOMER FOR BREACH OF THIS WARRANTY. GTR® AND IT’S VENDORS WILL NOT BE LIABLE FOR ANY INDIRECT, SPECIAL, INCIDENTAL, OR CONSEQUENTIAL DAMAGES IRRESPECTIVE OF WHETHER GTR® OR THE VENDOR HAS ADVANCE NOTICE OF THE POSSIBILITY OF SUCH DAMAGES.

There are no warranties which extend beyond the description mentioned in this document.

**Presentation**

This manual contains information on the installation of the VALUEGEN® generators.

**Notation**

 **NOTE: This is an example of a NOTE. NOTES are areas that need additional attention.**

 **CAUTION: This is an example of a CAUTION. CAUTIONS are procedures that the operator must heed in order to avoid damage to the equipment.**

 **WARNING: This is an example of a WARNING. WARNINGS are procedures that the operator must heed in order to avoid bodily harm or injury.**

## Applicability

This manual is applicable to the "v" Series, Single Tube RAD generators.

V-10	10 kW		
V-20	20 kW	V-325	20 kW
V-30	30 kW	V-425	30 kW
V-40	40 kW	V-550	40 kW
V-50	50 kW	V-650	50 kW

This manual is shipped with generator Model # \_\_\_\_\_, Serial # \_\_\_\_\_, with Software Version \_\_\_\_\_.

## Safety

### Mechanical-Electrical Warning



All of the electronic assemblies and parts of this equipment should be operated with care and routinely inspected in accordance with the manufacturer's recommendations.

Only properly trained and qualified personnel should be permitted access to any internal parts. Live electrical terminals are **LETHAL**. Be sure line disconnect switches are opened and other appropriate precautions are taken before removing covers or attaching accessories.

Do not remove the flexible high tension cables from the x-ray tube housing or high tension generator, and/or the access covers from the generator until the main and auxiliary power supplies have been disconnected.



**WARNING: Failure to comply with the foregoing safeguards may result in serious or fatal bodily injuries to the operator or those in the area.**



**WARNING: This product is not to be used in the presence of flammable anesthetics.**

### Electrical Grounding Instructions



**WARNING: The equipment must be grounded to an earth ground by a separate #8 conductor. The neutral side of the line is not to be considered the earth ground.**



**NOTE: This is "Type B" Equipment which employs both insulation protection and protective earthing to reduce the risk of electric shock to product users.**

## Environment

Storage and Transportation conditions:

Ambient Temperature Range: -40C to +65C

Relative Humidity Range: 20 to 80% (non condensing)

Atmospheric Pressure Range: -15 meters to 10000 meters

Operation Conditions:

This equipment is designed to work within a temperature range of 20°C to 30°C, with a relative humidity (non-condensing) less than 60%. Atmospheric Pressure Range: -15 meters to 3000 meters.



**CAUTION: Provide adequate filtration if the generator is installed in a high dust or particulate matter environment.**

## Radiation Warning



**WARNING: X-rays are dangerous to operator unless established safe exposure procedures are observed.**

The useful and scattered beams can produce serious or fatal bodily injuries to any persons in the immediate or surrounding area. Adequate precautions should be taken to avoid exposure to the central beam or to scattered radiation.

Persons authorized to operate the equipment should be familiar with the established safe exposure factors and procedures.

**Chapter 1: Specifications Ratings**

**CAUTION: For proper operation on a Single Phase or Three Phase Line, it is recommended that you have 220 VAC, -5%/+10% 50/60Hz.**

Voltage Requirements:	220 VAC (-5%/+10%)
Circuit Breaker Size:	100 Amps
Wire Type:	Stranded Copper
Wire Size:	#2 Wire for runs less than 50 feet #0 Wire for runs more than 50 feet
Power Line Impedance:	0.30 Ohms or less

kVp (In steps of 1 kVp)	40 to 125 V-10/20/30 V-325/425 40 to 150 V-40/50 V-550/650
mA	V-10 25 to 200 mA V-20 V-325 25 to 300 mA V-30 V-425 25 to 400 mA V-40 V-550 25 to 500 mA V-50 V-650 25 to 600mA
Time	2ms to 6 seconds

**Table 1-1 Technique Ranges**

Table 1-1 Technique Ranges

Technique Factors for maximum line current:

Radiographic:

20 kW = 100 kVp @ 200 mA > 20 ms

30 kW = 100 kVp @ 300 mA > 20 ms

The radiographic duty cycle can be one average exposure every 30 seconds. Mor specifically 300 mAs per minute ie. one 150 mAs every 30 seconds or 600 mAs every two minutes.

Methodology used to measure actual technique factors:

The kVp and mA is measured as the aveage of the top of the waveform.

The exposure time is measured from 75% of rise and fall of the kVp waveform.

mA	2ms to .5 sec.	.6	.7	.8	1.0	1.5	2.0	2.5	3.0	3.5	4.0	4.5	5.0	6.0
25														
50														
75														
100														
150														
200														

Table 1-1A Maximum Technique Selections (V-10)

mA	2ms to .5 sec.	.6	.7	.8	1.0	1.5	2.0	2.5	3.0	3.5	4.0	4.5	5.0	6.0
25														
50														
75														
100														
150														
200														
250														
300														

Table 1-1B Maximum Technique Selections (V-20/V-325/i-325)

mA	2ms to .5 sec.	.6	.7	.8	1.0	1.5	2.0	2.5	3.0	3.5	4.0	4.5	5.0	6.0
25														
50														
75														
100														
150														
200														
250														
300														
400	.1sec													

Table 1-1C Maximum Technique Selections (V-30/V-425/i-425)

mA	2ms to .5 sec.	.6	.7	.8	1.0	1.5	2.0	2.5	3.0	3.5	4.0	4.5	5.0	6.0
25														
50														
75														
100														
150														
200														
250														
300														
400														
500	.1 sec													

Table 1-1D Maximum Technique Selections (V-40/V-525/V-550)

mA	2ms to .5 sec.	.6	.7	.8	1.0	1.5	2.0	2.5	3.0	3.5	4.0	4.5	5.0	6.0
25														
50														
75														
100														
150														
200														
250														
300														
400														
500	.1 sec													
600	.1 sec													

**Table 1-1E Maximum Technique Selections (V-50/V-650)**

## Configuration

### Operator's Console

There are 3 Operator's Consoles that are available with the VALUEGEN® family of generators. They are:

Standard Operator's Console (Part Number 6065.00)

APR Operator's Console (Part Number 6072.00)

Refer to the illustrations below to determine the Operator's Console with your system.



**Standard Operator's Console (Part Number 6065.00)**



**APR Operator's Console (Part Number 6072.00)**





**NOTE:** Throughout the Technical Manual references are made to various aspects of the Operator's Console. These include the reconfiguration of displays during Setup (Chapter 4), Calibration (Chapter 5) and Compliance (Chapter 6). Familiarize yourself with the specific Operator's Console supplied with your system and take note of its characteristics.

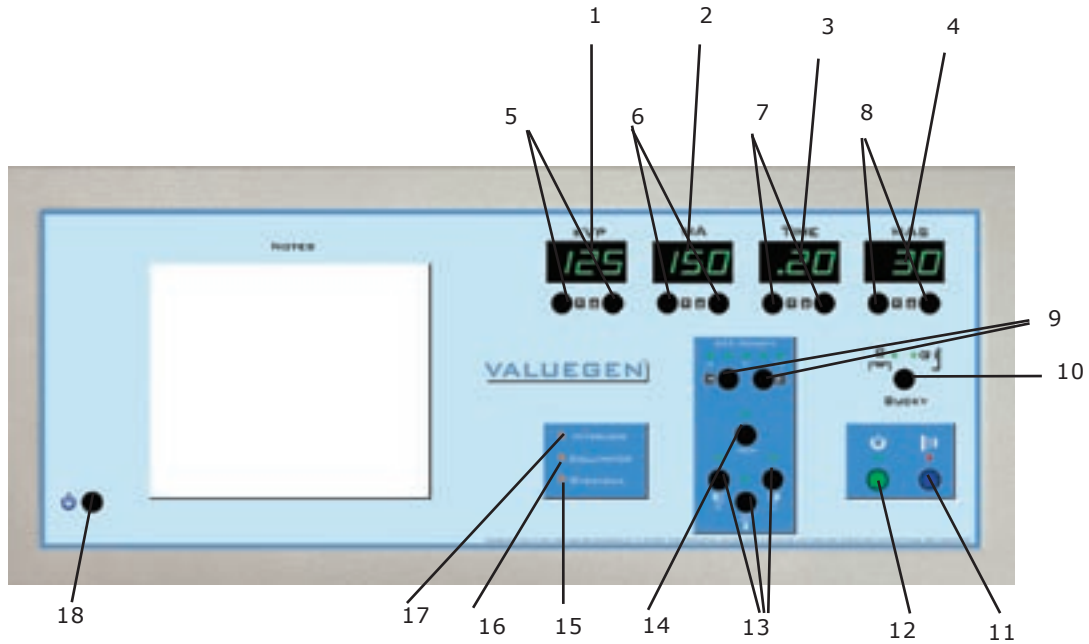

Figure 1-1A Standard Operator's Console (Front View)

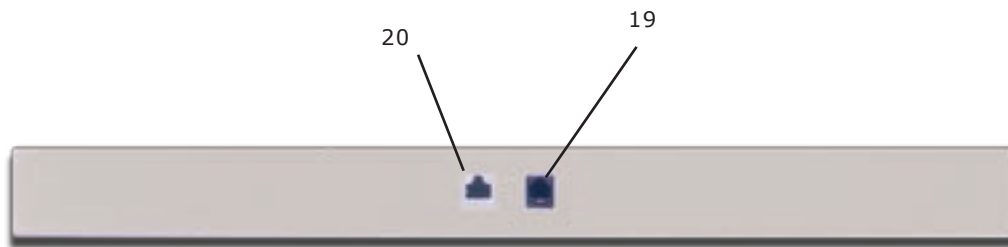

Figure 1-1B Standard Operator's Console (Rear View)

- |                        |                      |
|------------------------|----------------------|
| 1. kVp Display         | 13. AEC Field Select |
| 2. mA Display          | 14. AEC Reset        |
| 3. Time Display        | 15. Overload LED     |
| 4. mAs Display         | 16. Collimator LED   |
| 5. kVp Up/Down         | 17. Interlock LED    |
| 6. mA Up/Down          | 18. On/Off           |
| 7. Time Up/Down        | 19. Hand Switch      |
| 8. mAs Up/Down         | 20. Connector        |
| 9. AEC Density Up/Down |                      |
| 10. BKY Select         |                      |
| 11. EXP                |                      |
| 12. PREP               |                      |

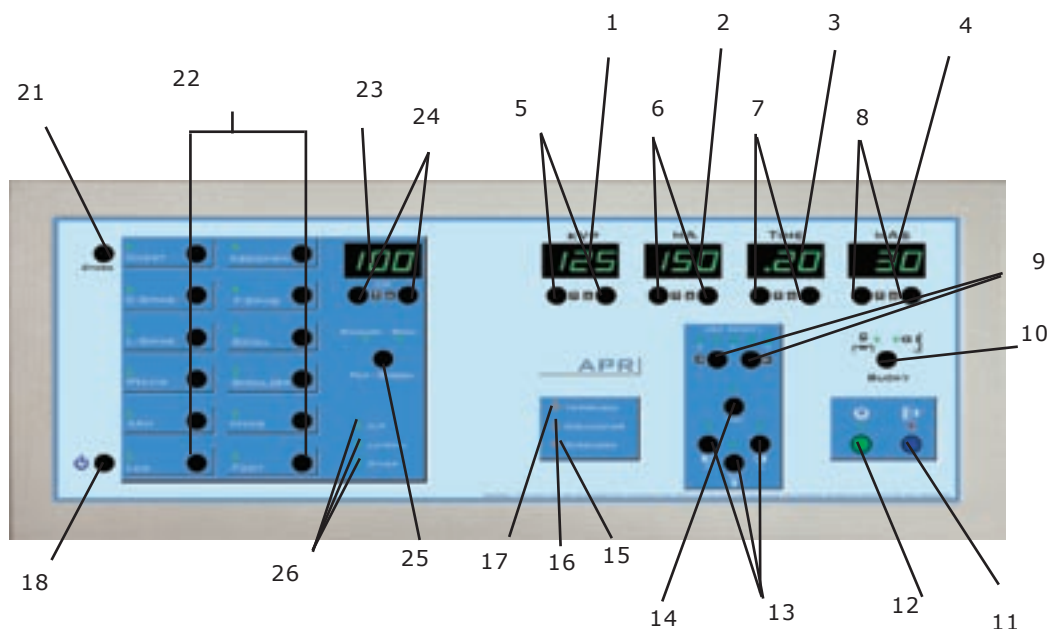

Figure 1-1A APR Operator's Console (Front View)

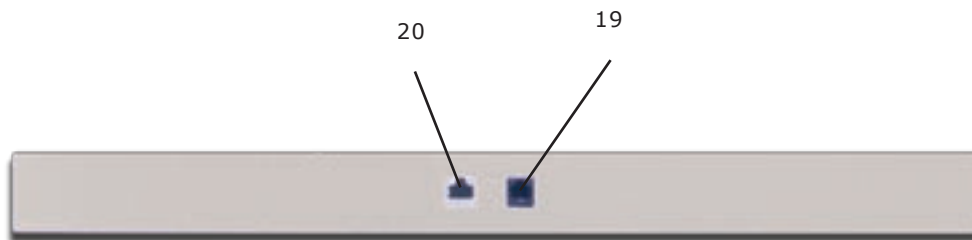

Figure 1-1B APR Operator's Console (Rear View)

- |                        |                      |                        |
|------------------------|----------------------|------------------------|
| 1. kVp Display         | 10. BKY Select       | 19. Hand Switch        |
| 2. mA Display          | 11. EXP              | 20. Connector          |
| 3. Time Display        | 12. PREP             | 21. Store              |
| 4. mAs Display         | 13. AEC Field Select | 22. APR Selections     |
| 5. kVp Up/Down         | 14. AEC Reset        | 23. Centimeter Display |
| 6. mA Up/Down          | 15. Overload LED     | 24. Centimeter Up/Down |
| 7. Time Up/Down        | 16. Collimator LED   | 25. Film/Screen Select |
| 8. mAs Up/Down         | 17. Interlock LED    | 26. A/P-Lateral-Other  |
| 9. AEC Density Up/Down | 18. On/Off           |                        |

### Modes of Operation

The APR Operator's Console has three (3) modes of operation:

- Manual Mode**
- APR Mode**
- AEC Mode**

Each mode has its own, specific characteristics of operation. Please read each description carefully to note the differences and similarities.

### Manual Mode

In the Manual Mode of operation the APR Operator's Console acts just like the Standard Console supplied with the VALUEGEN® generators. You may manually input values for kVp, mA, Time and mAs as well as select a Bucky (if the option is installed). Exposures are based on this manually entered technique.

APR functions are not available while in the Manual Mode.

The Manual Mode is indicated when the Centimeter Display is not illuminated and there are no AEC selections made (if the option is installed).

### APR Mode

The APR Mode is indicated by having the Centimeter Display illuminated and one of the green APR Selection LEDs lit. In the APR Mode the operator may make an APR Selection of anatomy region and view and select a Centimeter Thickness. This will automatically select and display a technique based upon the Technique Chart stored in memory.



**NOTE: In the APR Mode, with the Centimeter Display illuminated, pressing any pushbutton on the right side of the console will automatically put the console in the Manual Mode.**

### Change Individual Techniques

To change any of the individual techniques stored in any of the APR Selection locations, use the following procedure: Press and hold the STORE pushbutton (21) on the APR Operator's Console. While holding this pushbutton, select the anatomy region (ie. Chest), the view (ie. AP), the Centimeter Thickness (23), kVp, mA, Time, mAs and any optional equipment installed (ie. Bucky 1, AEC Field 2).

Release the STORE pushbutton and observe that the decimal point in the Centimeter Display illuminates momentarily to indicate storage of the technique.

This technique is now permanently stored in the selection you have made.



**NOTE: Storing a specific technique in this manner does not affect any of the other techniques stored in the APR Operator's Console.**

### Change Stored Techniques Globally

Version 2.0 of the Human Anatomical Console (APR) software adds the capability to automatically change the stored technique factors for increased or decreased film density. Incremental changes of approximately 0.3 optical density (OD) can be made by console pushbutton combinations. All stored technique factors can be changed at once or all thicknesses for one view can be changed at once. A change of approximately 0.9 OD is equivalent to doubling (halving) the film speed. Therefore increasing all technique factors by 0.3 three times is equivalent to changing from 400 speed to 200 speed film.

There are two ways to globally change the techniques stored in the APR Console Memory.

1. Change all technique factors stored in memory
2. Change all technique factors for a specific selected anatomical region.

#### Change All Technique Factors Stored In Memory

Make sure there is no APR view selected (no indication in CM Display).

Press STORE and AEC Density UP Pushbuttons simultaneously (the decimal point in the CM display will illuminate to indicate activity) This function increases all stored technique factors by approximately 0.3 OD.

OR

Press STORE and AEC Density DOWN Pushbuttons simultaneously (the decimal point in the CM display will illuminate to indicate activity). This function decreases all stored technique factors by approximately 0.3 OD.

#### Change All Technique Factors For An Anatomical Region

Select a specific APR view (ie. Chest AP or Skull LAT etc.).

Press STORE and AEC Density UP Pushbuttons simultaneously (the decimal point in the CM display will illuminate to indicate activity). This function increases all stored techniques for each CM station of the selected APR View by approximately 0.3 OD. No other factors are changed.

OR

Press STORE and AEC Density DOWN Pushbuttons simultaneously (the decimal point in the CM display will illuminate to indicate activity). This function decreases all stored techniques for each CM station of the selected APR View by approximately 0.3 OD. No other factors are changed.



**NOTE: During any of the above procedures, the decimal point in the CM Display will illuminate to indicate activity. This may take up to 30 seconds. During the time the decimal point is illuminated, no other operation is allowed.**



**NOTE: Pressing STORE and AEC RESET Pushbuttons simultaneously will reset all APR stored techniques to factory default.**



**NOTE: The Human APR Console must be set to the corresponding Model of the Generator for these new functions to work properly.**

### Set Model Number

For the Version 2.0 software changes of the Human APR Console to work properly you must set the Model Number of the generator as well. With the generator in the Service Mode the following displays will indicate the different model numbers. Pressing the corresponding pushbutton sets the console for the correct Model Number.

Chest	10kW
C-Spine	20kW i-325
L-Spine	30kW i-425
Pelvis	40kW
Arm	50kW

### Technique Transfer

Version 2.0 and higher of the Human APR Console allows for the internal transfer of technique factors to an EEPROM for storage and recall. If you customize your APR Technique settings you can save them for recall on the EEPROM.



**NOTE: You must be in the Service Mode to perform operations with the EEPROM.**

With the generator in the Service Mode press simultaneously the STORE and CM UP pushbuttons. This will store the techniques you have programmed into the console on the EEPROM. The decimal point in the CM Display will illuminate during transfer.

With the generator in the Service Mode press simultaneously the STORE and CM DOWN pushbuttons. This will transfer the techniques stored in the EEPROM back into the console. The decimal point in the CM Display will illuminate during transfer.

**If you experience a console failure and have to replace the console and you have previously stored the altered techniques in the EEPROM you may take the EEPROM out of the failed console and install it in the new console and execute a STORE/CM DOWN function in the service mode to restore your techniques in the new console.**

### AEC Mode

The AEC Mode is applicable if the generator has the AEC Option installed.

The AEC Mode is used in conjunction with the Manual Mode or the APR Mode.

The AEC Mode is indicated by one or more of the FIELD LEDs (13) being illuminated.

#### AEC Mode with Manual Mode:

The Operator must select a Backup Time of sufficient length to exceed the expected exposure time using AEC. It is suggested that this Backup Time be at least 2 times the expected exposure time.

#### AEC Mode with APR Mode:

None of the APR Selections contain AEC from the factory even if the AEC option is installed. All of the stored techniques are based upon the Technique Chart in Appendix 1 of this manual.

If the operator wishes to add AEC functions to the stored techniques you must follow the instructions for STORE in the above section on APR Mode.

When adding AEC to one or more of the stored APR Selections remember to select an appropriate Backup Time for each selection.



**CAUTION: Failure to program in a Backup Time for each APR Selection you add an AEC function to will result in the Backup Time warning LED being illuminated and require an AEC Reset.**



Figure 1-4 Cabinet (Front View)

Figure 1-6 Chassis (Right Side)

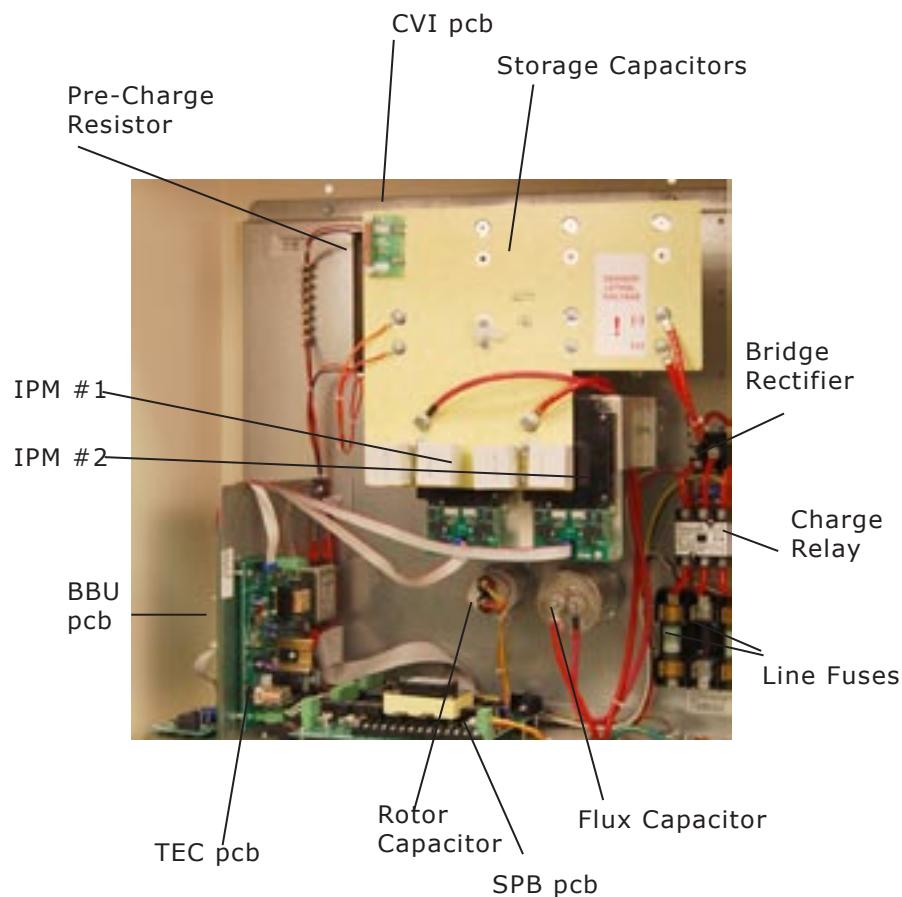
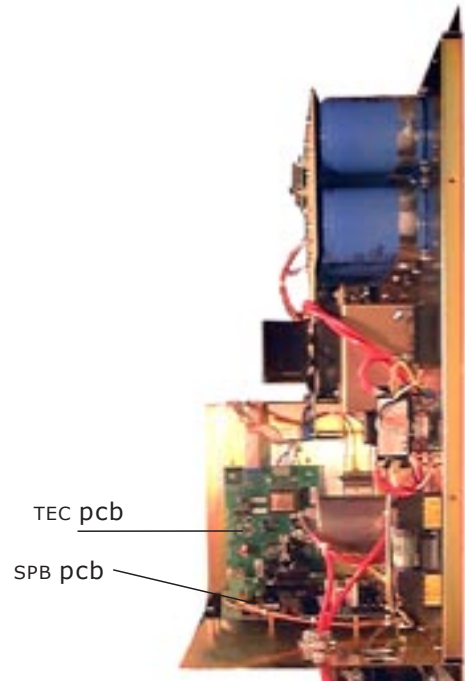
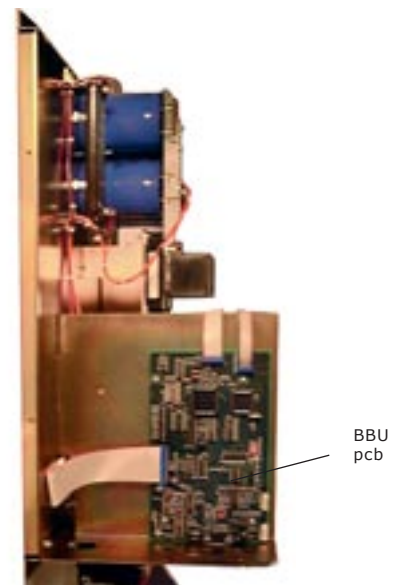

Figure 1-5 Chassis (Front View)

Figure 1-7 Chassis (Left Side)



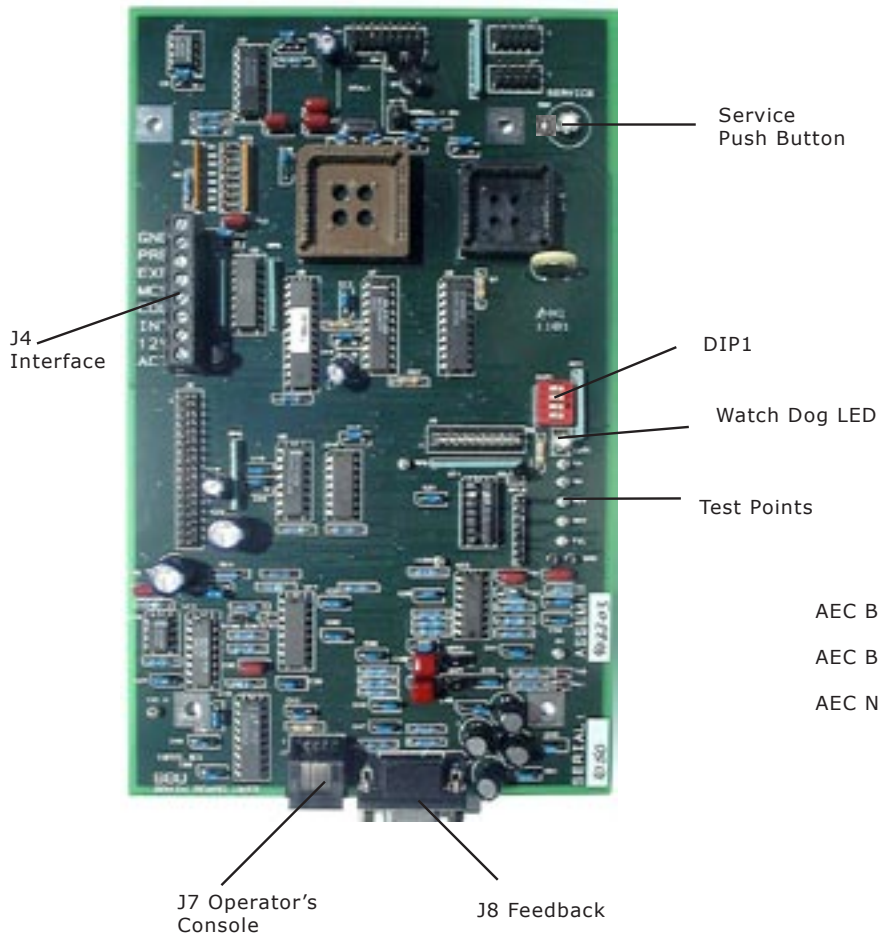

Figure 1-9 Brain Board (BBU)

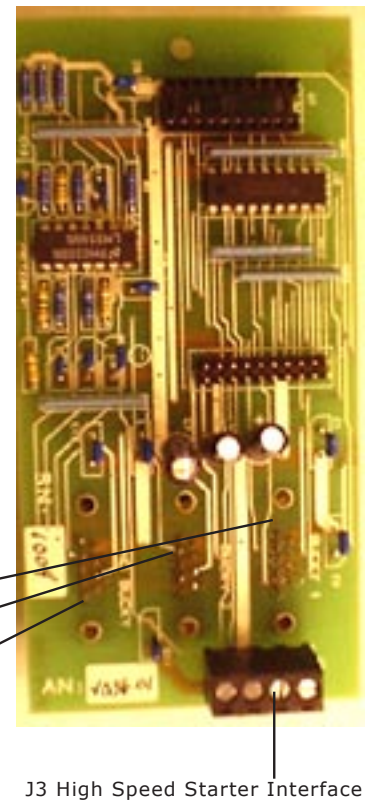

Figure 1-10 AEC/HSS pcb

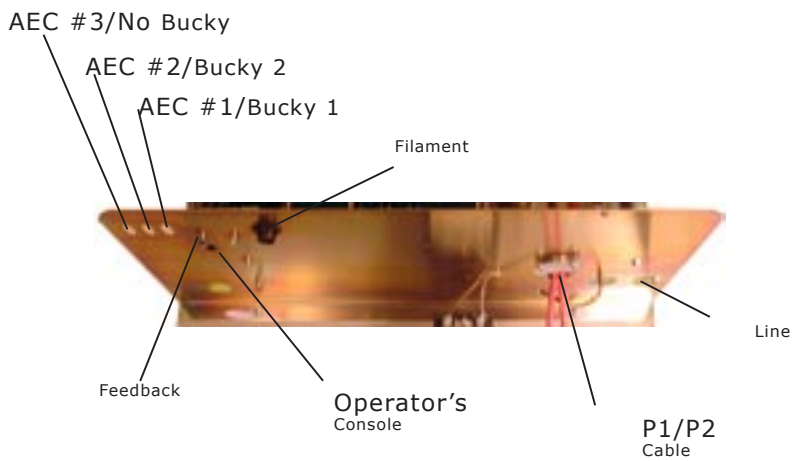

Figure 1-8 Chassis (Bottom View)

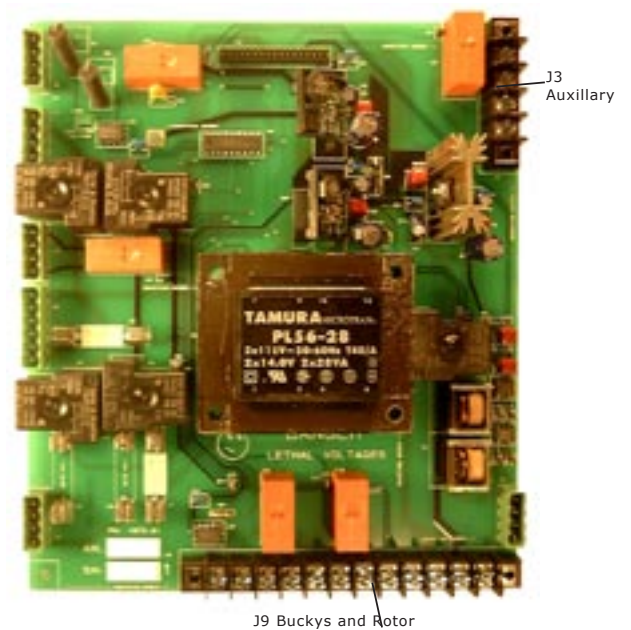

Figure 1-11 System Power Board

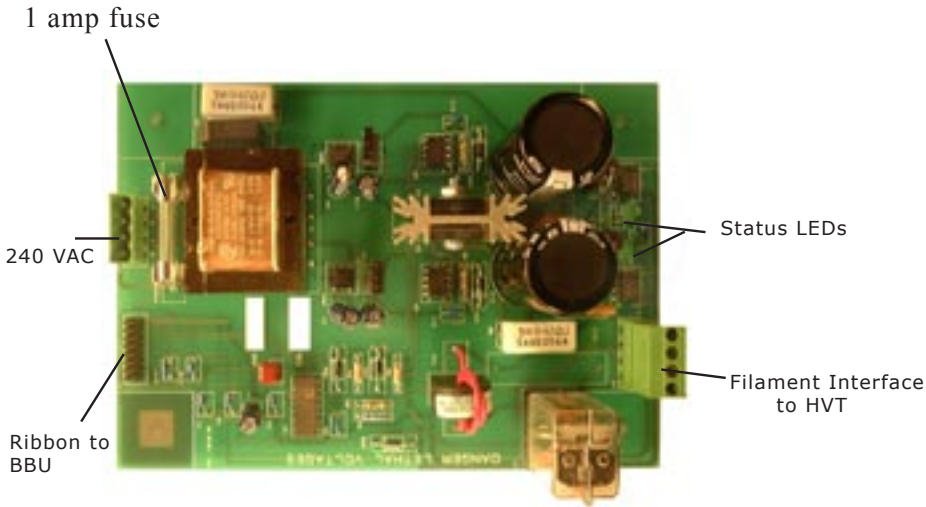

Figure 1-12 TEC (Thermionic Emission Controller)

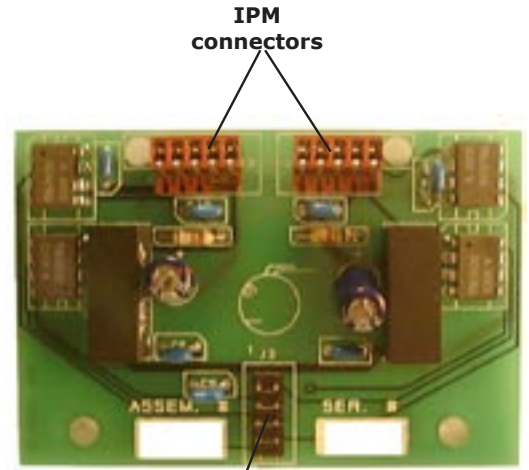

Figure 1-13 IPM Driver

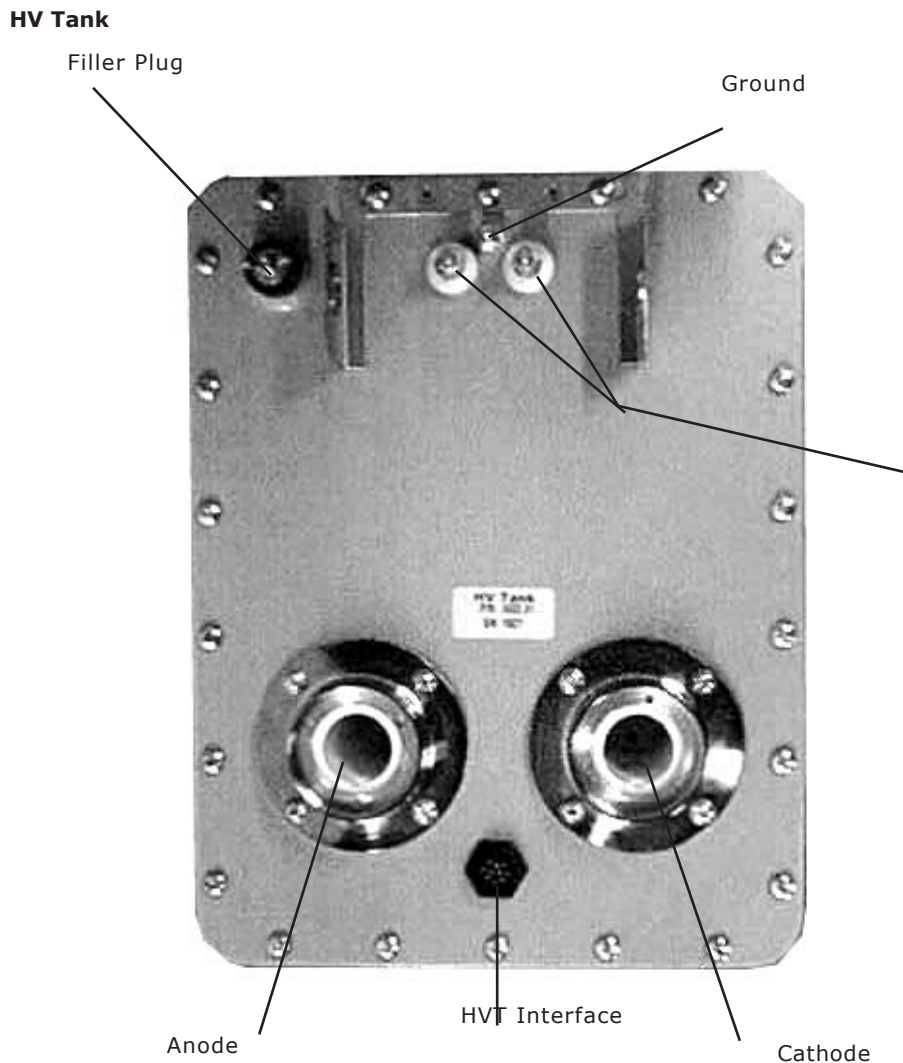

Figure 1-14 HV Tank (Top View)

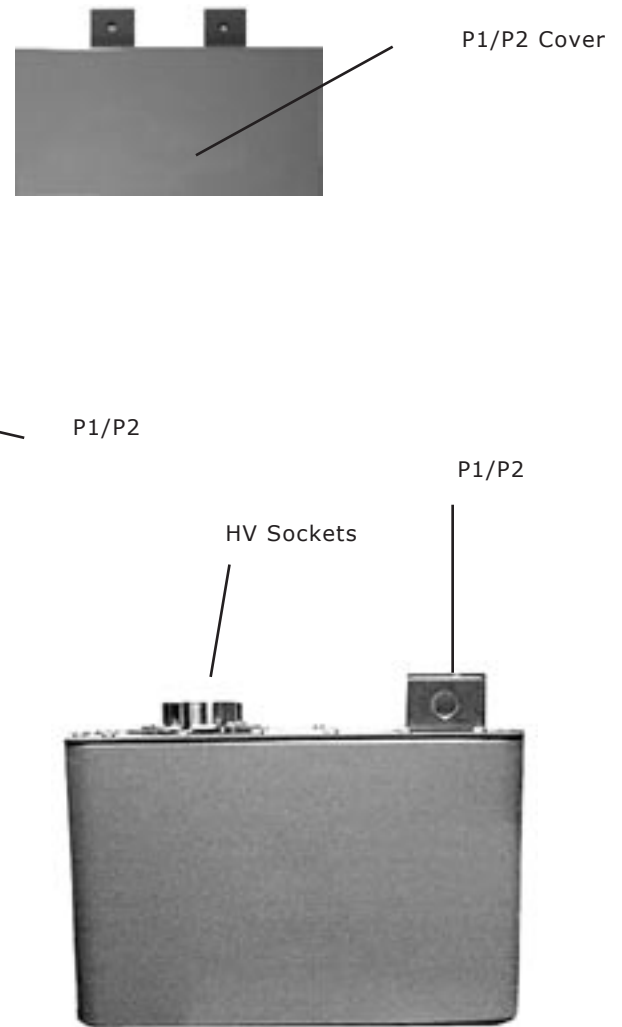

Figure 1-15 HV Tank (Side View)

## Chapter 2: Installation

### Site Preparation

The following factors should be considered when selecting a site for installation of the Cabint:

#### Environment:

This equipment is designed to work within a temperature range of 20°C to 30°C, with a relative humidity (non-condensing) of less than 40%.

#### Proximity to Mains Disconnect:

L1/L2/L3 connections should be as short as possible in order to minimize line drop during an exposure.



**NOTE: If less than 15' use #6 stranded wire from Mains Disconnect to F1/F2/F3. If greater than 15' use #4 stranded wire. Consult Local Electrical Code for the proper wire size between Mains Disconnect and Source.**



**WARNING: For proper operation of the generator you may not increase the length of the Interface Cable or the P1/P2 Cable.**

### Unpacking

The generator is shipped in one carton.

Carefully inspect the exterior of the carton for external damage. Report any damage immediately to the carrier. Damage due to mishandling during shipping or transportation is specifically not covered by the manufacturer's warranty.



**NOTE: Damage due to mishandling during shipping or transportation is specifically not covered by the manufacturer's warranty.**

#### HV Tank

Remove the HV Tank from the carton. Open the plastic bag and inspect for an oil leak. Some seepage is normal due to pressure changes in shipping.



**NOTE: Due to pressure changes in shipping and transportation, residual amounts of oil may leak from the HVT and be evident on the carton or packing materials.**

Release the seal on the HV Tank (with the HV Tank in its normal, upright position) by turning the wing nut on top of the filler plug counterclockwise several times until it is loose.

#### Cabinet

Remove the Cabinet from the carton. Open the plastic bag and inspect for damage to the cover.

### Inspection



**WARNING: It is critical that you conduct a complete visual inspection of the components of the generator after unpacking.**

Every precaution is taken during the final test and packing procedures to ensure that all screws and fasteners are secured tightly and that all circuit boards are seated properly.

However, it is the responsibility of the installer to inspect carefully prior to the first application of power.

Failure to follow this step could result in damage to the generator as well as injury to personnel.



### HV Tank

The High Voltage cable wells are covered by red plastic plugs. Remove the plugs and ensure that the wells are clean and free of any contaminant.

Inspect the sides of the tank. They should be smooth and without indentations.

Inspect the pins on the Interface Connector. Remove any residue that may have accumulated during shipping. Ensure that all the pins are straight.

Remove the cover protecting P1/P2 and inspect the brass studs. Note the presence of the proper mounting hardware.

### Cabinet

Inspect the cover of the Cabinet. It should be smooth without any indentations other than the air vents.

### Operator's Console

Unwrap and inspect the Operator's Console. The plastic case should be solid and without cracks or scratches.

The graphic overlay should be without blemish and you should be able to see each of the 7 segment LED displays through the green filters on the display windows.

The rear panel should be intact with the connector for the Interconnecting Cable and the Hand Switch.

## Mechanical Installation

### Wall Mount Bracket



**WARNING: The Cabinet is not free-standing. If sited so that the bottom shelf is flush with the floor you must use the two top mounting holes to secure the Wall Mount Bracket to the wall to prevent the Cabinet from falling over.**

Remove the 4 1/4-20 nuts which secure the GCU chassis to the Wall Mount Bracket. Remove the GCU chassis from the Wall Mount Bracket.

The Wall Mount Bracket can be sited flush with the floor or suspended on the wall. (See Warning above.)

If you install the Wall Mount Bracket flush with the floor you must use the two top mounting holes to secure the Wall Mount Bracket to the wall to prevent the Cabinet from falling over.

If you install the Wall Mount Bracket suspended on the wall you must use all 6 mounting holes to secure the Wall Mount Bracket.

Once the Wall Mount Bracket has been secured to wall using one of the above methods, you may mount the HV Tank and GCU chassis.

Cable Access is through the bottom right and/or left corner of the Wall Mount Bracket.

### HV Tank

The HV Tank weighs approximately 85 lbs (38 kgs) and must be mounted in an upright position on the bottom shelf of the Wall Mount Bracket.

If the local building code requires that the HVT be secured mechanically to a mounting surface, you may drill holes in the bottom shelf of the Wall Mount Bracket.

### GCU

The GCU chassis weighs approximately 35 lbs (16 kgs). Secure the Chassis to the Wall Mount Bracket using the 4 1/4-20 studs provided.

Cable access to the GCU is through the bottom panel. Refer to Figure 1-6 in Chapter 1.

### Operator's Console

The Operator's Console is designed to mount on a shelf or desk top in the Control Booth. The 25' (7.5 meter) Interconnecting Cable connects between the rear of the Operator's Console and the bottom panel of the GCU.

## Interconnection

Interconnection of the generator consists of three cables supplied with the generator.

### P1/P2 Cable

This consists of 2 #8 Red Wires and a #8 Green/Yellow Ground Wire with one end already attached inside the GCU. It

is packed coiled against the bottom panel of the GCU.

#6 round terminals are attached to the open end of the cable for connection to the P1/P2 and Ground studs on the HV Tank.

The ground wire attaches to the Ground stud. Connect the other two wires to P1 and P2. The order is not critical.



**CAUTION: P1/P2 connections are brass studs. It is possible to strip the threads on these studs or break them if you over tighten the locknuts. Do not use excessive force when tightening these connections.**

### Interface Cable

The Interface Cable connects the HV Tank to the GCU. It consists of a 30" (80 cm) cable with a single connector on the HV Tank end and two (2) connectors on the GCU end. (Refer to Figure 2-4)

Connect the single connector to the HV Tank.

At the GCU connect the 4 conductor round connector to the Filament connector on the Bottom Panel.

Connect the 9 pin D-Sub connector to the Feedback connector on the Bottom Panel.



**Figure 2-4 Interface Cable**

### Interconnecting Cable

Route the 25' (7.5 meter) Interconnecting Cable from the Bottom Panel of the GCU through conduit or trough to the Control Booth.

One end connects to the rear panel of the Operator's Console and the other end connects to the Bottom Panel of the GCU.

### Hand Switch

If your generator includes an optional Hand Switch, connect it to the rear of the Operator's Console (refer to Fig. 1-1B {25}).

This is a two position Hand Switch. The first position is PREP and the second position is EXP. These switches are in parallel with the PREP and EXP push buttons on the Operator's Console.



**Figure 2-5 Hand Switch**

## Chapter 3: Interface

### Mains

#### Single Phase, 220 VAC (V-10/20/30 V-325/425)

Connect 220 VAC -5%/+10 50/60Hz, 1 Phase to F1/F2 in the GCU from Mains Disconnect. Refer to Figure 3-1A. Input to the GCU is through the access hole on the Bottom Panel. Refer to Figure 1-6 in Chapter 1.

 **NOTE: If less than 15' use #6 stranded wire from Mains Disconnect to F1/F2. If greater than 15' use #4 stranded wire.**

 **WARNING: The equipment must be grounded to an earth ground by a separate #8 conductor. The neutral side of the line is not to be considered the earth ground.**

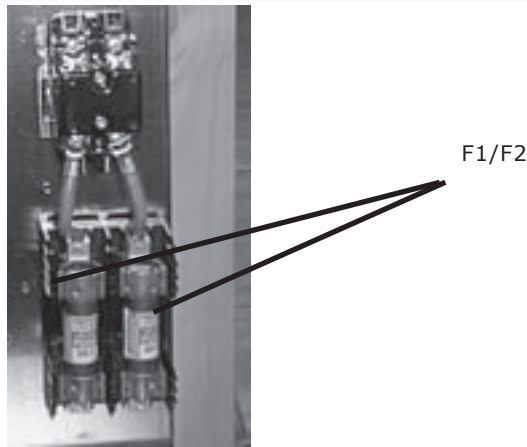



Figure 3-1A F1/F2 Location

#### 3 Phase, 220 VAC (V-40/50 V-550/650)

Connect 220 VAC -5%/+10% 50/60Hz, 3 Phase to F1/F2/F3 in the GCU from Mains Disconnect. Input to the GCU is through the access hole on the Bottom Panel. Refer to Figure 1-6 in Chapter 1.

 **NOTE: If less than 15' use #6 stranded wire from Mains Disconnect to F1/F2/F3. If greater than 15' use #4 stranded wire.**

 **WARNING: The equipment must be grounded to an earth ground by a separate #8 conductor. The neutral side of the line is not to be considered the earth ground.**

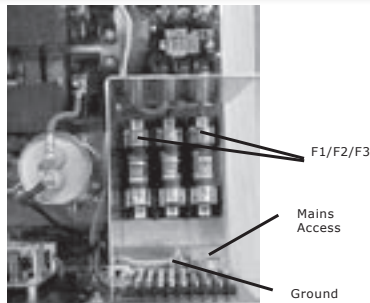

Figure 3-1B F1/F2/F3 Location



**SAFETY WARNING:** If your generator is configured from the factory for 380 VAC, 3 Phase Operation it will have a Neutral Post. The generator must be connected to a 5 wire "Y" power source (3 phases, Ground and Neutral).



**Connection to any other source is not allowed!**

### 3 Phase, 380 VAC

Connect 380 VAC 50/60Hz, 3 Phase to F1/F2/F3, Neutral and Ground in the GCU from Mains Disconnect. Refer to Figure 3-1C.

Input to the GCU is through the access hole on the Bottom Panel. Refer to Figure 1-6 in Chapter 1.



**NOTE:** If less than 15' use #6 stranded wire from Mains Disconnect to F1/F2/F3. If greater than 15' use #4 stranded wire.



**WARNING:** The equipment must be grounded to an earth ground by a separate #8 conductor. The neutral side of the line is not to be considered the earth ground.

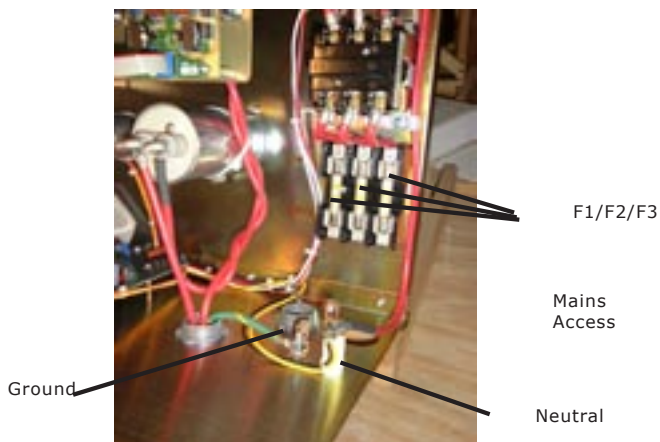

Figure 3-1C F1/F2/F3 Location

### Buckys

Connect Bucky (or Buckys) to J9 Terminal Block on the SPB pcb. (Refer to Figure 3-2.)

Input to the GCU is through the access hole on the Bottom Panel. Refer to Figure 1-6 in Chapter 1.



**WARNING:** The Bucky Motion Inputs must be a "contact to ground" (NO VOLTAGE!). Any voltage on this input will result in damage to the equipment.



**NOTE:** Buckys are active only if the specific option is installed.

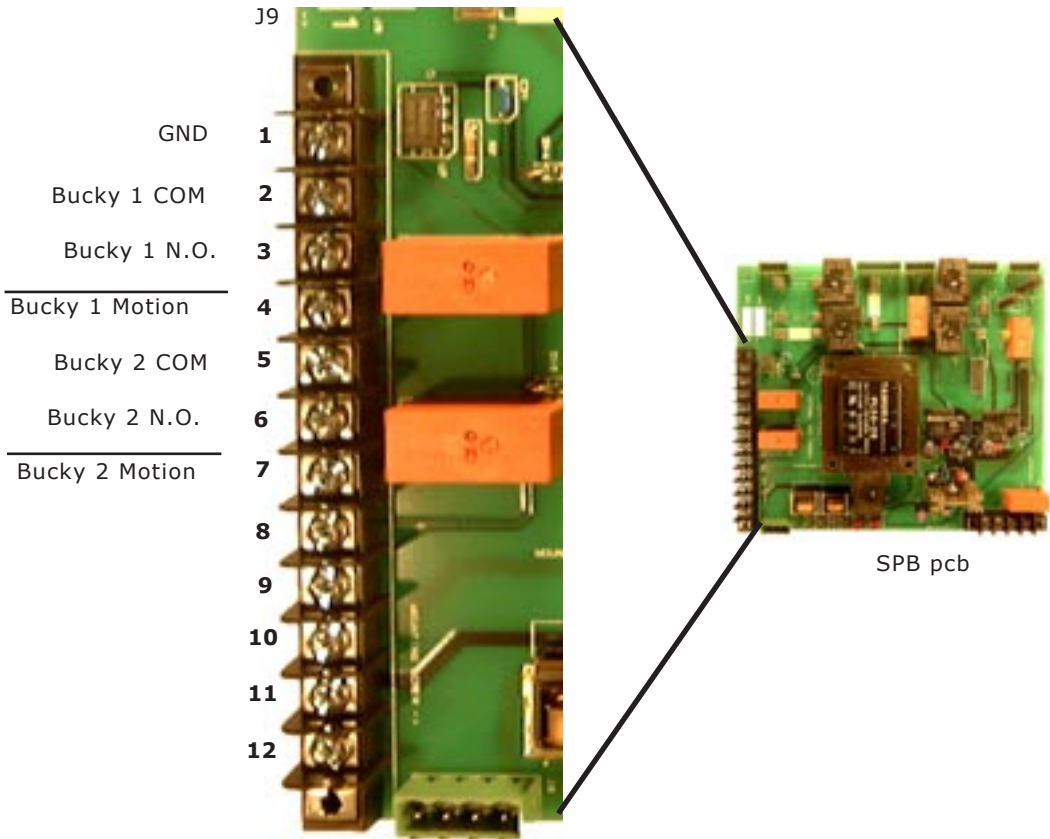
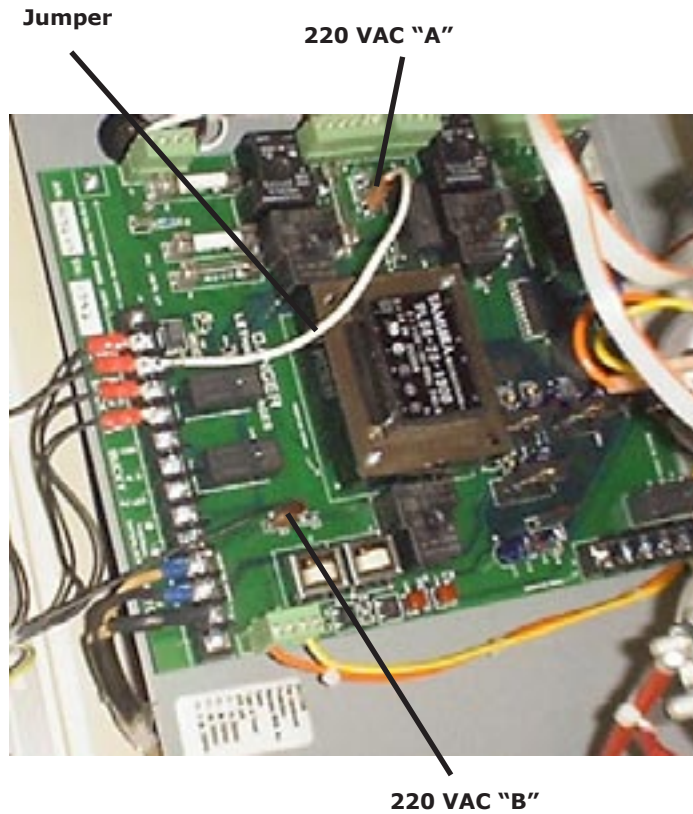

Figure 3-2 Bucky Connections

V-RAD SYSTEM BUCKY CONNECTIONS



All Buckys supplied with V-RAD SYSTEMS are switched for 220 VAC operation. That 220 VAC is now available on the SPB pcb at the locations indicated above.

Follow the wiring directions on the label on the Bucky cable. The directions follow the diagram below. Bucky 1 is assumed to be the Table and Bucky 2 is assumed to be the Wall Stand in a 2 Bucky system.

Bucky Conn.	Bucky 1	Bucky 2
B1	GND J9-1	GND J9-1
B2	Bucky 1 Mot J9-4	Bucky 2 Mot J9-7
B3	Bucky 1 N/O J9-3	Bucky 2 N/O J9-6
B4	220 VAC "B"	220 VAC "B"
B6	Earth	Earth
B8	Bucky 1 COM J9-2	Bucky 2 COM J9-5
	Jumper 220 VAC "A" to J9-2	Jumper 220 VAC "A" to J9-5

SIMPLIFIED BUCKY CONNECTIONS

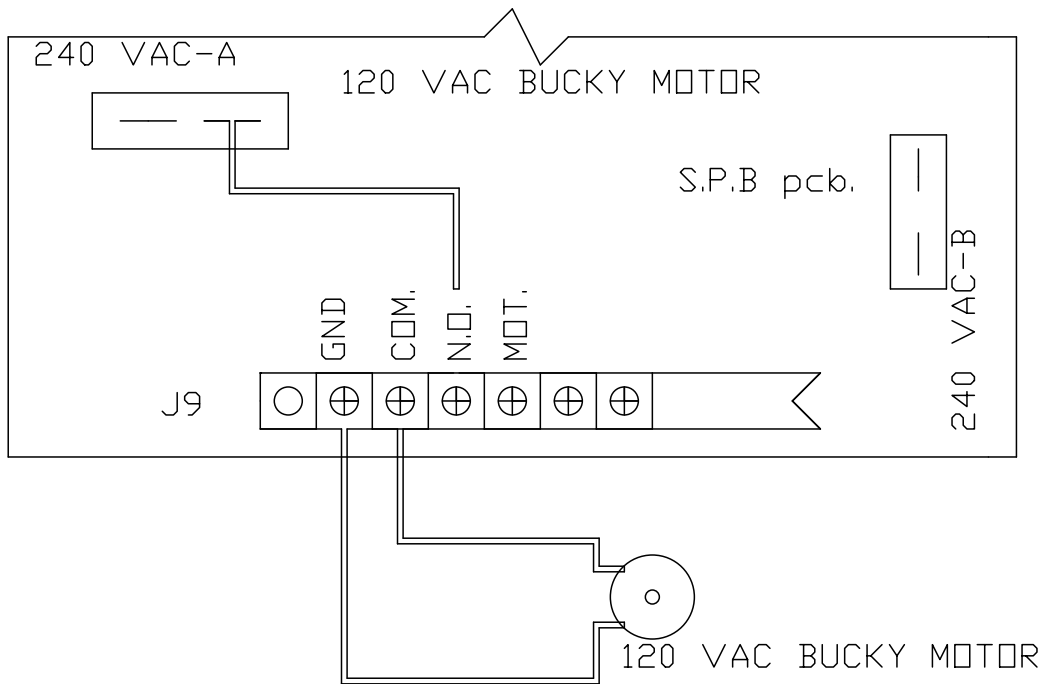

**120 VAC BUCKY MOTOR CONNECTION (BUCKY 1)**

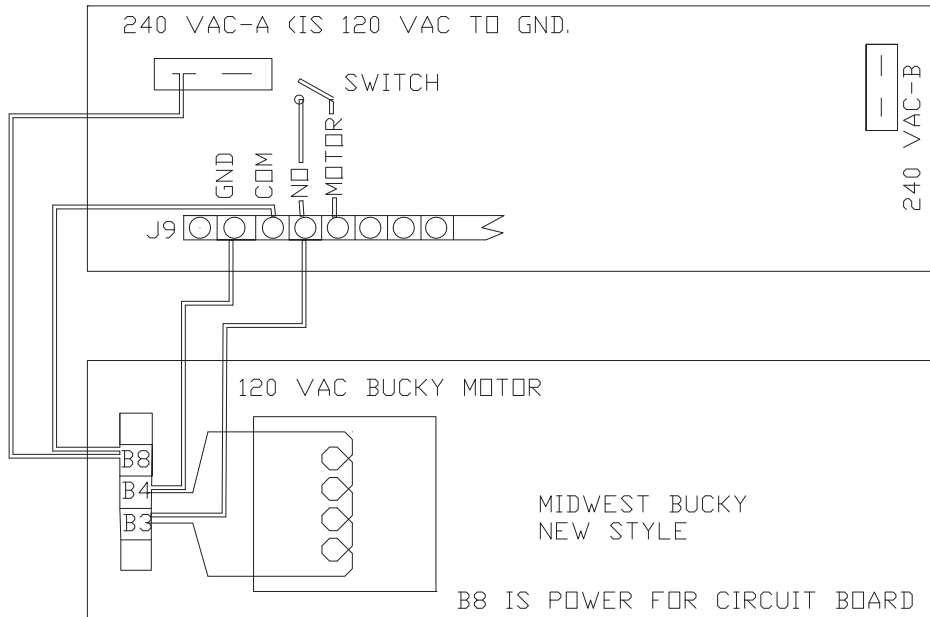

240 VAC BUCKY MOTOR CONNECTION (BUCKY 1)



**WARNING: The Bucky Motion Inputs must be a "contact to ground" (NO VOLTAGE!). Any voltage on this input will result in damage to the equipment.**

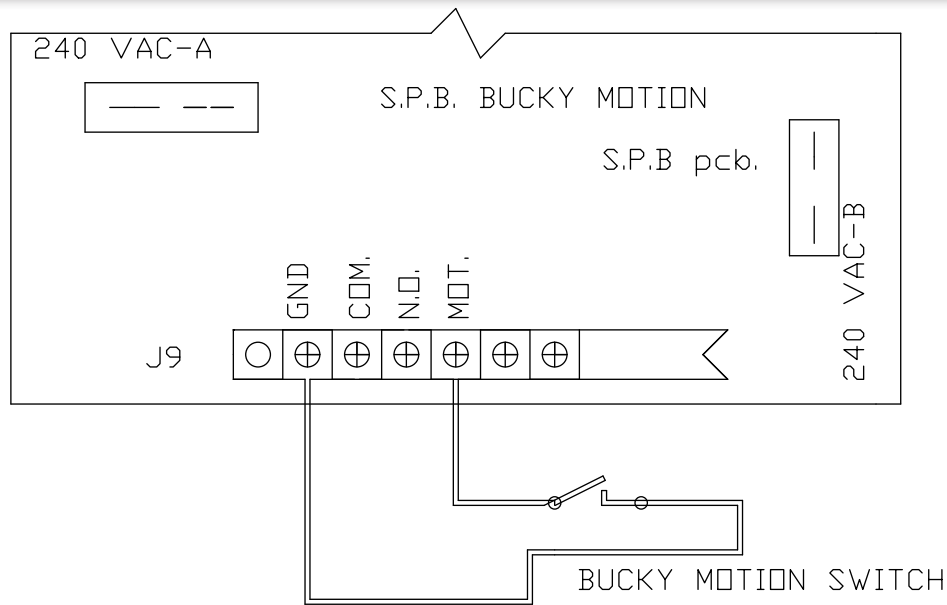

BUCKY MOTION CONNECTION (BUCKY 1)



**WARNING: The Bucky Motion Inputs must be a "contact to ground" (NO VOLTAGE!). Any voltage on this input will result in damage to the equipment.**

## Rotor

Connect the Rotor to J9 Terminal Block on the SPB pcb. (Refer to Figure 3-5).

Input to the GCU is through the access hole on the Bottom Panel. Refer to Figure 1-6 in Chapter 1.



**WARNING: The Common terminal for the Rotor(Rotor COM) is connected to one side of the AC Line at all times. DO NOT CONNECT AN X-RAY TUBE WITH A GROUNDED ROTOR TO THIS SYSTEM! Failure to heed this WARNING will result in catastrophic failure of the x-ray tube in a very short time.**

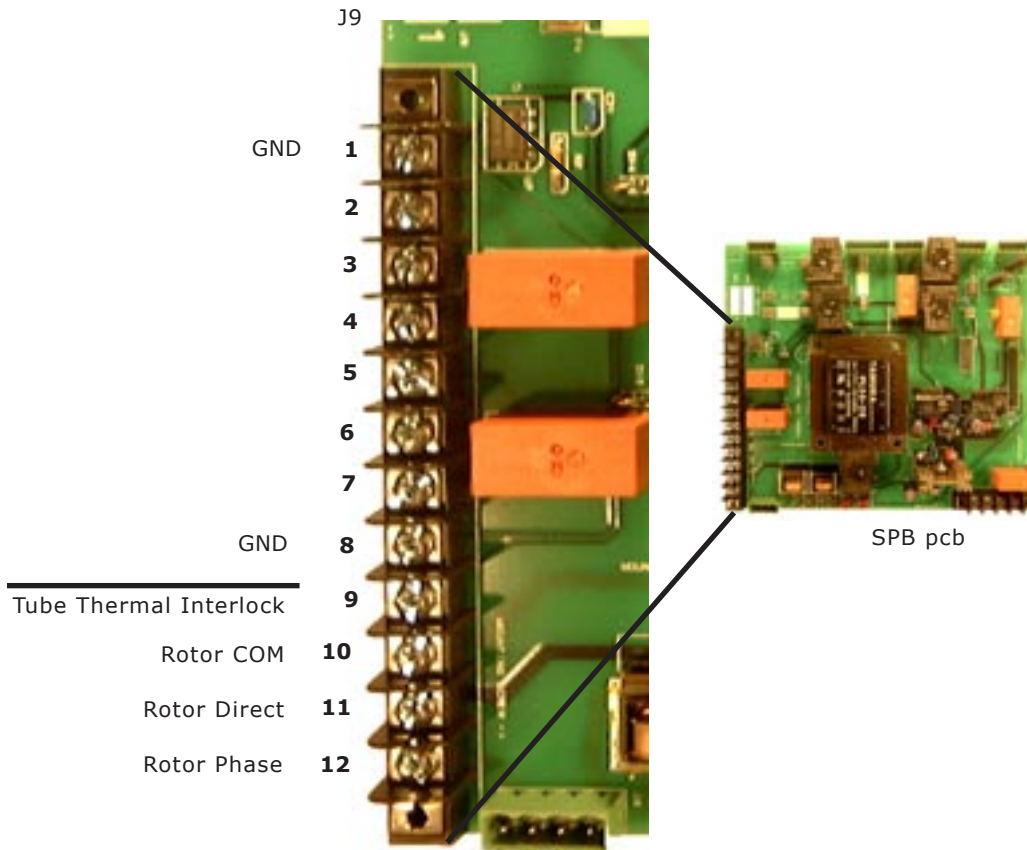



### External Handswitch/Footswitch

Connect an External Handswitch/Footswitch to the J4 Terminal Block on the BBU. Refer to Figure 3-6. Input to the GCU is through the access hole on the Bottom Panel. Refer to Figure 1-6 in Chapter 1. All connections must be a "dry contact" (No Voltage!) to ground.

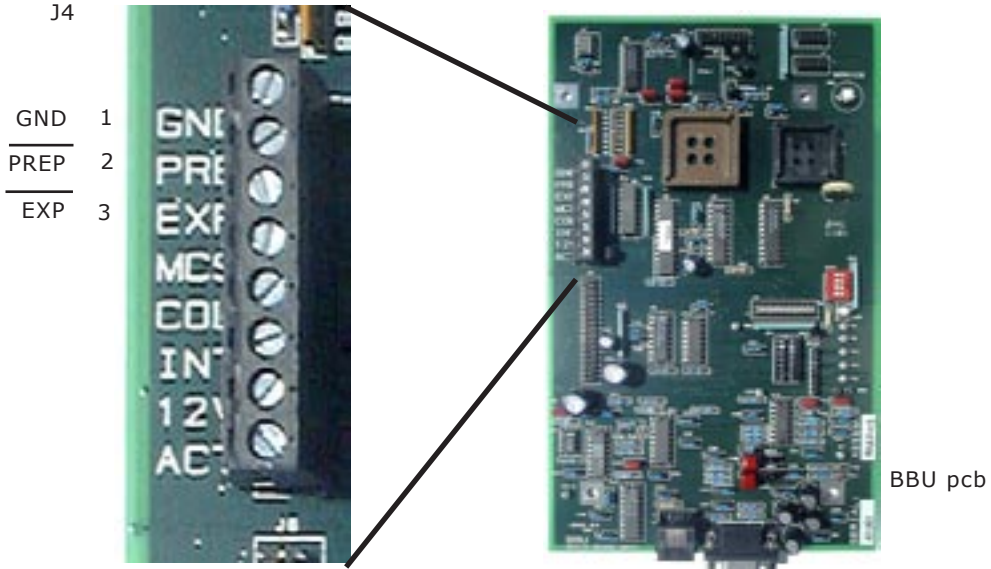

Figure 3-6 Handswitch/Footswitch Connections

### Interlocks

Connect Door and Collimator Interlocks to the J4 Terminal Block on the BBU pcb. Refer to Figure 3-7. Input to the GCU is through the access hole on the Bottom Panel. Refer to Figure 1-6 in Chapter 1. All connections must be a "dry contact" (No Voltage!) to ground.

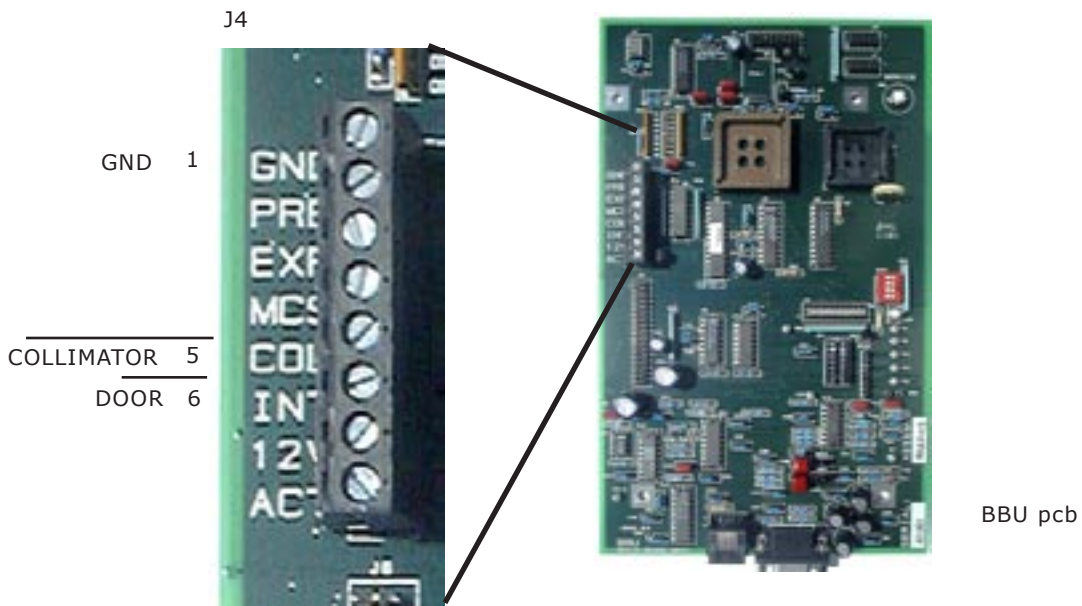

Figure 3-7 Interlock Connections

 **NOTE: Interlocks are disabled from the factory. If you use them you must enable them in Chapter 4, Setup.**

## AEC

Connect Ion Chambers to input connectors on Bottom Panel of GCU. Refer to Figure 3-8.



**NOTE: Ion Chamber selection is based upon configuration programming in Chapter 4: Setup.**

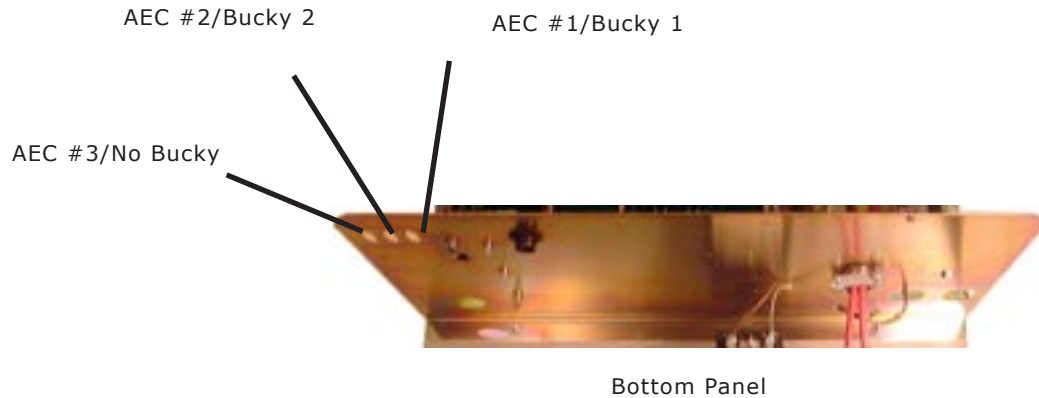

**Figure 3-8 AEC Ion Chamber Connections**



**NOTE: The AEC circuitry is compatible with positive slope Ion Chambers only.**



**NOTE: AEC is active only if the specific option is installed.**

## Auxillary Relay

An Auxillary Relay is provided on the SPB pcb. This relay may be used to switch on power to other devices in the x-ray room (ie. table, tube stand, etc.).

Two sets of normally open contacts are provided at J3 on the SPB pcb (refer to Figure 3-9). These contacts close after a normal power up sequence.



**NOTE: The maximum rating for the relay contacts is 8 Amps @ 250 VAC.**



**WARNING: For safety and compliance with the National Electrical Code, you must provide fuse protection for any voltage switched by this Auxillary Relay.**

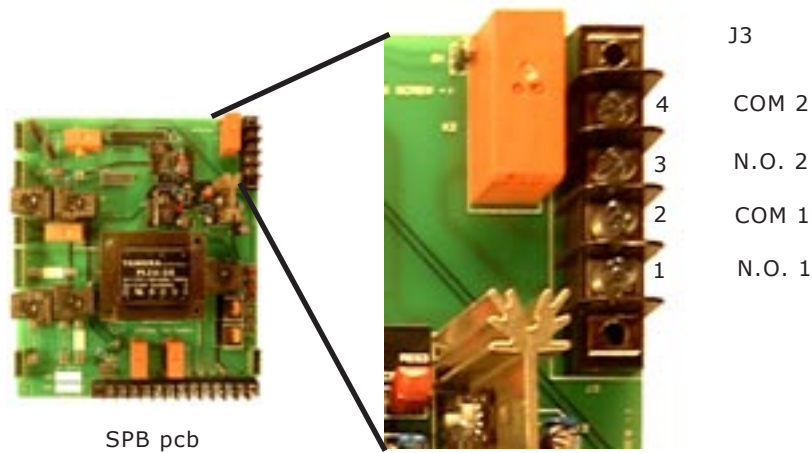

Figure 3-9 J3 Auxillary Relay Connections

### 24 VAC Collimator Lamp Power

A step-down transformer is supplied, mounted to the Wall Mount Bracket, for 24 VAC Collimator Lamp Power. (Refer to Figure 3-10).

Input power for this transformer comes from the SPB pcb and is present after a normal power up sequence.

Output power is 24 VAC @ 8 Amps.

 **NOTE: The primary connections for the transformer are not connected during shipping. They must be connected after the wall mount bracket has been mounted to the wall and the GCU Chassis has been re-installed.**

Figure 3-10 24VAC Transformer



### External Exposure Indication

An open collector output is provided at J4-8 on the BBU pcb for an external exposure indication. Refer to Figure 3-11.

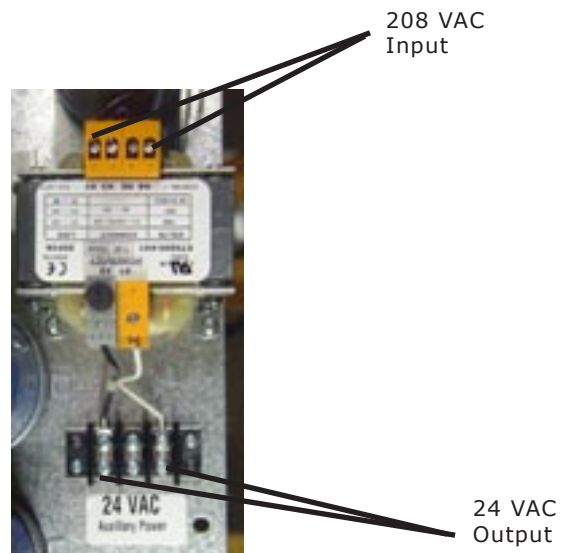
The output is active low and is present during an exposure sequence.

The output has a minimum on time of 75 milliseconds.

 **WARNING: The maximum rating for this open collector output is 30 VDC @ 100 mA. If the device you attach requires a higher rating, use this output to energize a relay.**

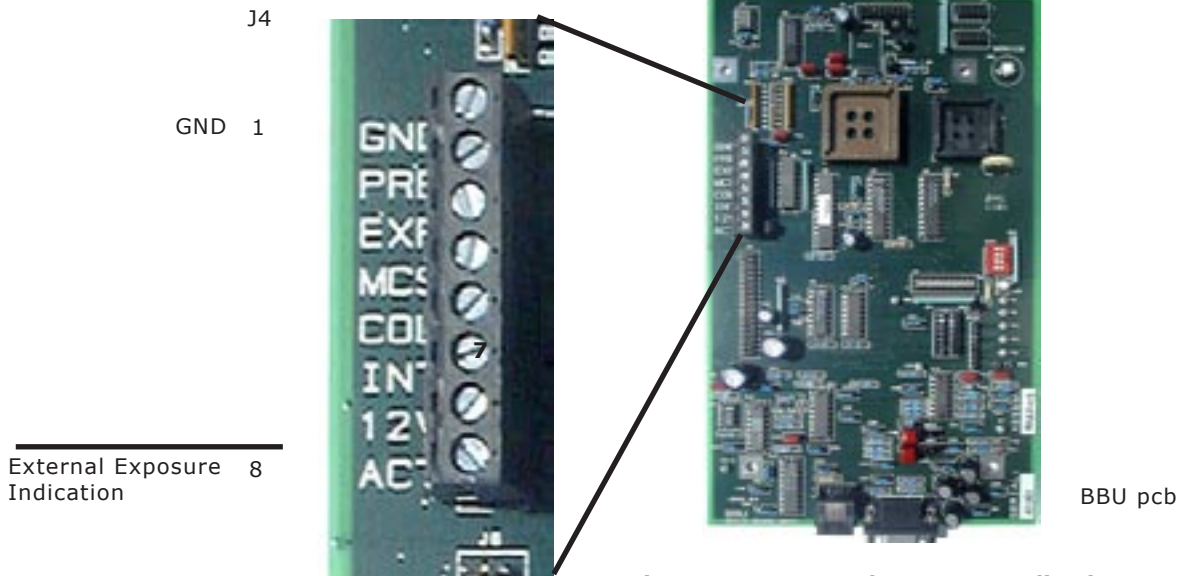

Figure 3-11 External Exposure Indication

## High Speed Starter Interface

A High Speed Starter Interface is provided in the V-40/50 and V-550/650 generators.



**NOTE: If a High Speed Starter is connected to the generator, do not connect the Rotor to TB-1. Connect the Rotor as indicated in the High Speed Starter Technical Manual.**



**NOTE: If you select an x-ray tube in Pre-Set # [≡00] that does not have High Speed Rotor capability, you will not be able to select a 1 for Pre-Set # [≡22].**

The interface for the High Speed Starter is on connector J3 of the AEC/HSS pcb. Refer to Figure 3-12. The signals and their descriptions are according to Table 3-1.

SIGNAL	CONNECTION	DESCRIPTION
HSSGO	J3 pin 1	Open Collector Output Pulled low on PREP if Pre-Set #22 set to 180
HSSHI	J3 pin 2	Open Collector Output High Speed Requested Pulled low on PREP if Pre-Set #22 set to 180
GND	J3 pin 3	Ground Connection
HS NT	J3 pin 4	Opto-Coupled Input Pulled low for Rotor Interlock

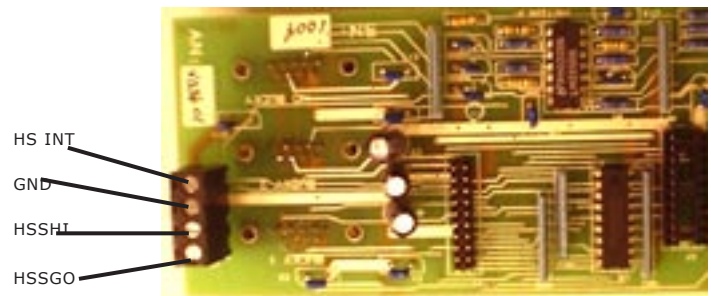

Table 3-1 High Speed Starter Connections

## Chapter 4: Setup

### Overview

This chapter covers the initial Power On Test, selecting the mA Stations, initializing all preset variables and testing the Filament.



**CAUTION: The generator is shipped with DIP1-1 on the BBU pcb in the OFF position. This disables the drive to the TEC pcb as well as the Pre-Charge and Charge relays. Do not move this switch to the ON position until directed to do so in this manual.**

In addition to the Self-Diagnostic functions built into the generator, there are several additional safety features. One of these is the Diagnostic Interlock. This Diagnostic Interlock allows the microprocessors to detect if the HV Tank feedback cable is disconnected.

On Power Up if the HV Tank feedback cable is disconnected you will have an Error Code E01 displayed on the kVp Display of the Operator's Console.



**CAUTION: Do not operate the generator with any of the circuit boards, the HVT, or the Operator's Console disconnected.**



DIP1-1

Figure 4-1 BBU pcb

### Power On Test



**NOTE: This test presumes you have performed the Inspection and Interconnection steps detailed in Chapter 2 of this manual. If you have not performed these steps please return to Chapter 2 and complete them at this time.**

#### Blue Watch Dog LED

The Blue Watch Dog LED on the BBU pcb provides additional information. When the Line Disconnect is first turned on the LED will illuminate for approximately 2 to 4 seconds. During this time the processor is initializing and you cannot turn on the Operator's Console. At the end of this initialization period, the Blue Watch Dog LED will go out.

When you press the On/Off Pushbutton on the Operator's Console the Blue Watch Dog LED will illuminate and stay on as long as the Console is on and there are no errors. If an error occurs, in addition to the Error Code being displayed in the kVp Display of the Operator's Console, the Blue Watch Dog LED will blink the number of times corresponding to the Error Code.

#### Power On

Switch on the wall disconnect. The Blue Watch Dog LED should illuminate steady for approximately 2 to 4 seconds and then go out. This indicates a normal power up sequence for the processor.



**WARNING: DANGER: When the wall disconnect is switched on, 208 VAC stand-by power is present on the SPB pcb even if the Operator's Console is switched off. Lethal voltages are present on the pcb and care should be taken to avoid electrical shock.**



On/Off Pushbutton

Figure 4-2 Operator's Console

Momentarily press the On/Off push-button switch on the front of the Operator's Console. **Do not hold the switch down.** Press and release.

There will be a slight delay during which the microprocessors are initializing. Then you will hear an audible tone and the displays on the Operator's Console will illuminate. The Blue Watch Dog LED on the BBU pcb will illuminate and stay on. This indicates a normal Power Up sequence.

If this does not occur, read the Error Code on the kVp Display of the Operator's Console and refer to Chapter 7, Diagnostics.

During a normal Power Up sequence the generator initializes the microprocessors and checks the following data:

- Battery Backup RAM
- Communications
- Diagnostic Interlock
- Power Supplies

If you have no Error Codes showing on the Operator's Console and the Blue Watch Dog LED is illuminated, the generator has executed a normal Power Up sequence and is ready to proceed with the initialization process.



**NOTE: You must return DIP1-1 to the ON position and initiate a Power On sequence before proceeding.**

You must initiate a Power On sequence in order to reset the generator's microprocessors. Momentarily press the On/Off Pushbutton on the rear of the Operator's Console. This will turn the generator off.

Move DIP1-1 on the BBU pcb to the ON position and momentarily press the On/Off push-button on the front of the Operator's Console. This will initiate a Power On Sequence.

## Pre-Set #s

This section covers the following steps:

- Select the X-Ray Tube
- Select Small mA Stations
- Select Large mA Stations
- Select Filament Standby Number for Small Filament
- Select Filament Standby Number for Large Filament
- Select the Rotor Boost Time
- Select Bucky's and AEC (if option installed)
- Select Interlocks
- Select High Voltage Cable Length
- Select Maximum kVp

Refer to Table 4-1 for the Pre-Set # adjustments and their order of appearance. Space is provided in the Table for you to note the settings you make during this sequence for future reference.

Pre-Set #	Description	Factory Setting	Notes
0 0	X-Ray Tube Selection	0	
0 1	1st mA Station, 25mA	1	
0 2	2nd mA Station, 50mA	1	
0 3	3rd mA Station, 75mA	1	
0 4	4th mA Station, 100mA	1	
0 5	5th mA Station, 150mA	2	
0 6	6th mA Station, 200mA	2	
0 7	7th mA Station, 250mA	2	
0 8	8th mA Station, 300mA	2	
0 9	9th mA Station, 400mA	2	
1 0	10th mA Station, 500mA	2	
1 1	11th mA Station, 600mA	2	
1 2	FIL Standby # (Small)	200	
1 3	FIL Standby # (Large)	200	
1 4	HV Cable Length	15	
1 5	Bucky 1 Select	0 *	
16	Bucky 2 Select	0 *	
17	AEC - No Bucky Select	0 *	
18	AEC - Bucky 1 Select	0 *	
19	AEC - Bucky 2 Select	0 *	
21	Maximum kVp	**	
22	Rotor Speed	50/60/180	
23	Low Speed Boost Time	***	
24	Tube Thermal Interlock	0	
25	Collimator Interlock	0	
26	Door Interlock	0	
27	Software Version		
32	kVp Feedback Test		

Table 4-1 Pre-Set Number Selection

\* Only available on the i-325/425 if the option is installed. If the option is not installed, these numbers will not move.

\*\* 125 kVp for the i-325/425.

\*\*\* 1.7 sec for the i-325/425.

With the generator on and no Error Codes showing on the Operator's Console, momentarily press the Service Push Button. Refer to Figure 4-5.

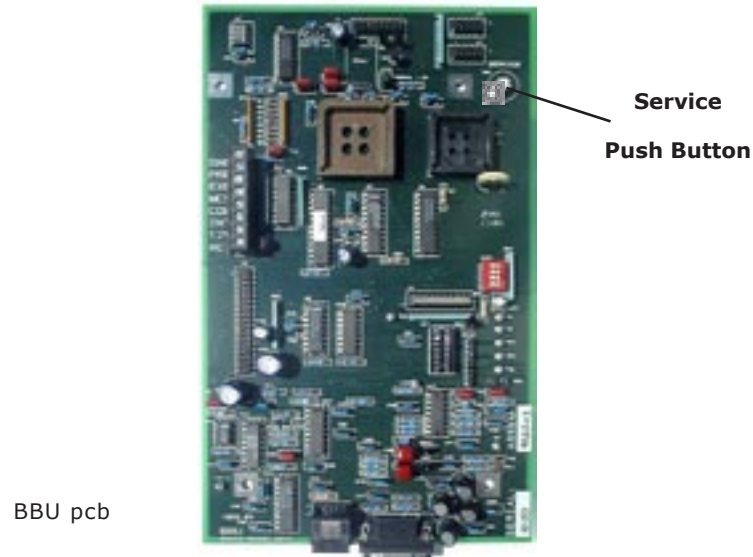

**Figure 4-5 Location of SERVICE Push Button**

This puts the generator in the Set Up mode. The mAs Display on the Operator's Console becomes the Pre-Set # Display.

The first character will display this symbol [≡]. Refer to Figure 4-6.

Pressing the Up/Down push-buttons associated with the mAs Display allows you to scroll forward and reverse through the Pre-Set # selections.

The selection values associated with each individual Pre-Set # are displayed on the Time Display. Pressing the Up/Down push-buttons associated with the Time Display allows you to change the value in memory for that Pre-Set #.



**CAUTION: The value displayed on the Time Display is the value in memory for that Pre-Set #. Take care not to accidentally change any of the values.**



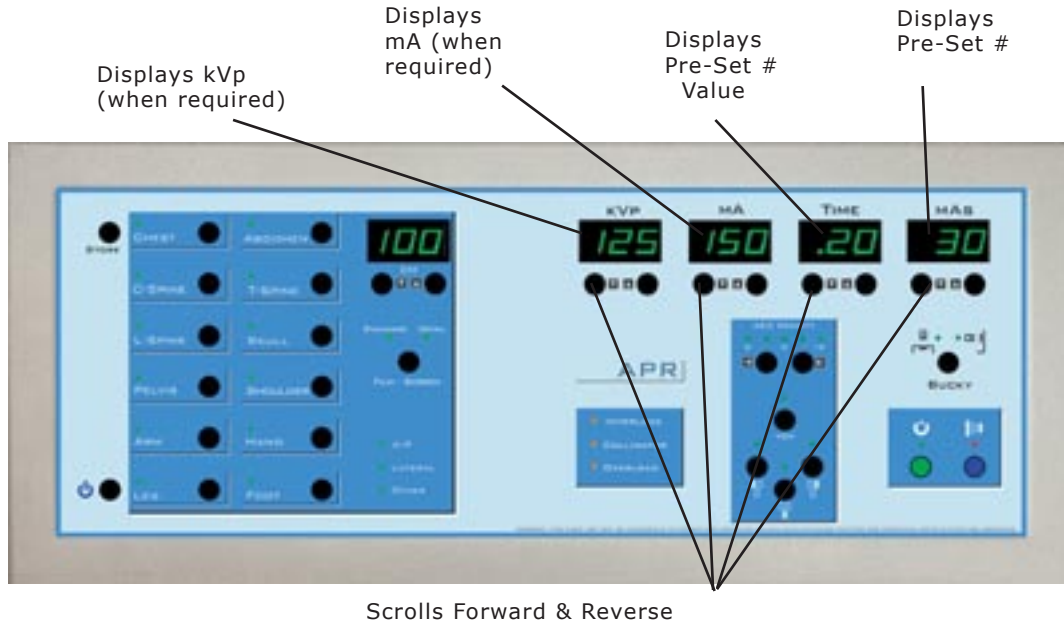



Figure 4-6 APR Operator's Console SERVICE Configuration

**X-Ray Tube Selection**

When you enter the SERVICE Mode, the first Pre-Set # which appears in the mAs Display is the X-Ray Tube Selection # [≡00]. The Factory Setting for this value (as displayed in the mA Display) is [0]. With a [0] showing in the Time Display you have the default x-ray tube selected. This tube is a generic tube used for testing and shipping.

Do not leave this setting at [0]. Select the x-ray tube you are using from Table 4-2. If your tube is not listed on the table, select a tube with similar filament characteristics.



**WARNING: If the x-ray tube you are using is not listed in Table 4-2 and there is no tube in the table with similar filament characteristics, do not proceed. Tube protection is only available with the tubes listed in Table 4-2 or tubes with similar filament characteristics. Failure to heed this WARNING may result in catastrophic failure of the x-ray tube.**

Use the Up/Down push-buttons for the Time Display to scroll forward and reverse through the available X-Ray Tube numbers.

When you have the X-Ray Tube you want selected, use the Up/Down push-buttons for the mAs Display to proceed to the next Pre-Set #.

The tube number will be stored automatically.

Tube #	Description	Focal Spot	50Hz	60Hz	180Hz
00	Eureka RAD 44	1.0/2.0	X	X	X
01	Eureka RAD 8	1.0/2.0	X	X	
02	Eureka RAD 9	0.6/1.5	X	X	
03	Eureka RAD 13	1.0/2.0		X	X
04	Eureka RAD 14	0.6/1.2	X	X	X
05	Eureka RAD 14	0.6/1.5	X	X	X
06	Eureka RAD 16	1.0/2.0	X	X	X
07	Eureka RAD 20	0.6/1.2		X	X
08	Eureka RAD 21b	0.6/1.2	X	X	X
09	Eureka RAD 40b	0.6/1.0		X	X
10	Eureka RAD 40c	0.6/1.2		X	X
11	Eureka RAD 40d	0.6/1.5		X	X
12	Eureka RAD 44	1.0/2.0	X	X	X
13	Eureka RAD 55a	0.6/1.2		X	X
14	Eureka RAD 55b	0.6/1.5		X	X
15	Eureka RAD 56	0.6/1.0		X	X
16	EIMAC A256	0.6/1.0	X	X	X
17	EIMAC A292	0.6/1.2	X	X	X
18	EIMAC A416	1.0/2.0		X	X
19	EIMAC A492	0.6/1.2		X	X
20	EIMAC A102	1.0/2.0	X	X	X
21	EIMAC A132	0.6/1.2	X	X	X
22	EIMAC 192	0.6/1.2	X	X	X
23	Toshiba E7239	1.0/2.0	X	X	X
24	GE Maxiray 100 - 12.5°	0.6/1.25	X	X	X
25	GE Maxiray 100 - 12.5°	0.6/1.5	X	X	X
26	GE Maxiray 100 - 12.5°	0.6/1.0	X	X	X
27	Eureka RAD 74	0.6/1.5	X	X	X
28	Toshiba E7242	0.6/1.5	X	X	
29	EIMAC G292	0.6/1.2		X	X
*30	C.E.I OX/105-4	2,6	X	X	
31	COMET DI9-30/50-150		X	X	
32	GENDEX UX-42	0.6/1.5	X	X	
33	BEL DRA1	1.2/2.0	X		
34	Toshiba E7240	0.6/1.2	X	X	
35	Toshiba E7252	0.6/1.2	X	X	X
36	RAD 68	0.6/1.2	X	X	
37	RAD 68	1.0/2.0	X	X	
38	Philips RO 1230	0.6/1.2	X	X	



**NOTE: 50 Hz data is not available for some x-ray tubes. If you have selected (50) for Setup location [≡22], you cannot select an x-ray tube unless an "X" appears in the 50Hz column.**



**\*NOTE: This tube has a fixed anode and is rated at 5 kW. Selecting this tube automatically disables the rotor circuit and sets 5 kW as maximum output (100 kVp @ 50 mA).**

**Table 4-2 X-Ray Tube Selection**

**mA Station Selection**

You have a maximum of 11 mA Stations which you can program on the V-50/V-650 generator, 10 on the V-40/V-550, 9 on the V-30/V-425, 8 on the V-20/V325 and 7 on the V-10.

You may use any combination between the large and the small filaments.

 **NOTE: In the Time Display there are three (3) numbers which will be displayed.**

0	Not Programmed or Not Available
1	Programmed on Small Filament
2	Programmed on Large Filament

**Small mA Station Selection**

Review the factory settings in Table 4-1. If the settings are ok no further action is required.

If you wish to make a change in any of the selections use the following procedure.

With the Setup Location for the mA station showing in the mAs display, select the desired programming in the mA display.

Your options are:

- 0 Not Programmed or Not Available
- 1 Programmed on Small Filament
- 2 Programmed on Large Filament

**Large mA Station Selection**

Review the factory settings in Table 4-1. If the settings are ok no further action is required.

If you wish to make a change in any of the selections use the following procedure.

With the Setup Location for the mA station showing in the mAs display, select the desired programming in the mA display.

Your options are:

- 0 Not Programmed or Not Available
- 1 Programmed on Small Filament
- 2 Programmed on Large Filament

**Filament Standby Number**

The generator has the capability of adjusting the standby current through the large and small filaments independently of each other.

The filament standby current is adjusted by increasing or decreasing the number displayed on the Time Display of the Operator’s Console during Set Up.

This number does not directly correlate to an actual amount of filament current. It is subjective and the adjustment procedure is augmented by visually inspecting each filament and monitoring the FIL I test point on the BBU pcb as you make the adjustment.



**Figure 4-7 FIL I Test Point**

FIL I Test Point  
GND



**NOTE: The range of filament numbers for Standby is [0] to [230]. The Factory Setting is [200]. Since filament characteristics vary from x-ray tube to x-ray tube it is strongly recommended that you return this value to [200] when replacing an x-ray tube.**



**CAUTION: Monitor the FIL I test point on the BBU pcb during Filament Standby Number adjustment. Do not exceed the maximum allowable filament current for the focal spot you are adjusting. At the FIL I test point, 1 VDC = 1.3 Amp Filament Current.**

#### Small Filament Standby Number

Using the Up/Down push-buttons for the mAs Display, scroll through the Pre-Set #s until you have [=12] displayed on the mAs Display. Monitor the FIL I test point on the BBU pcb with a Digital Voltmeter or an oscilloscope. 1 VDC = 1.3 Am.

Using the Up/Down push-buttons for the Time Display, increase the Filament Number until the filament begins to illuminate. Determine that you are adjusting the Small Filament by visual inspection.

Continue adjusting the number until the filament is bright enough. In no case should the FIL I exceed 2.75 Amps. Record this value in Table 4-1 for future reference.

#### Large Filament Standby Number

Using the Up/Down push-buttons for the mAs Display, scroll through the Pre-Set #s until you have [=13] displayed on the mAs Display.

Monitor the FIL I test point on the BBU pcb with a Digital Voltmeter or an oscilloscope. 1 VDC = 1.3 Amp.

Using the Up/Down push-buttons for the Time Display, increase the Filament Number until the filament begins to illuminate.

Determine that you are adjusting the Large Filament by visual inspection.

Continue adjusting the number until you reach a maximum of 2.75 Amps or the Large Filament is bright enough.

Record this value in Table 4-1 for future reference.

#### HV Cable Length

The length of the HV Cables is a factor in the shape of the kVp waveform.

This effect is non-linear and more pronounced at the lower kW levels.

The generator compensates for this effect automatically.

With Pre-Set # [=14] showing in the mAs Display, select the approximate length of the HV Cables connected to the generator using the Up/Down push-buttons for the Time Display. The length is displayed in increments of 5 feet.



**NOTE: For cable length not divisible in 5 feet increments, select the next lowest setting on the mA Display. For instance: for a cable length of 17 feet, select the setting of 15 feet on the Time Display.**

## Buckys and AEC Selection

The generator will operate 2 Buckys and 3 Ion Chambers for AEC if the options are installed. Each of these functions can be programmed independently.



**NOTE: For Pre-Set #s [≐15] and [≐16] you have three choices on the Time Display; [0], [1] and [2]. [0] = disabled, [1] = enabled (bucky) and [2] enabled (tomo).**



**NOTE: For Pre-Set #s [≐17] through [≐19] you have two choices on the Time Display; [0] or [1]. [0] = disabled, [1] = enabled.**



**NOTE: Bucky's and AEC are active only if the specific option is installed.**

### Bucky 1 Select

If you have connected a Bucky to the Bucky 1 position of J9 select a [1] for Pre-Set # [≐15]. For Tomo select a [2]. If none select a [0].

### Bucky 2 Select

If you have connected a Bucky to the Bucky 2 position of J9 select a [1] for Pre-Set # [≐16]. For Tomo select a [2]. If none select a [0].

### AEC - No Bucky Select

The generator has the capability of operating an Ion Chamber without the selection of a Bucky for table top, stretcher or wheel chair use.

This condition is selected by having both BKY 1 and BKY 2 LEDs not illuminated on the Operator's Console.

The interconnection point for this Ion Chamber is AEC #3 on the Bottom Panel of the GCU (refer to Figure 1-6)

If you have connected an Ion Chamber to AEC #3 select a [1] for Pre-Set # [≐17]. If not select a [0].

### AEC - Bucky 1 Select

If you have connected an Ion Chamber to AEC #1 and it is installed in Bucky 1 select a [1] for Pre-Set # [≐18]. If not select a [0].

### AEC - Bucky 2 Select

If you have connected an Ion Chamber to AEC #2 and it is installed in Bucky 2 select a [1] for Pre-Set # [≐19]. If not select a [0].

### Maximum kVp

The Maximum kVp selectable by the Operator can be programmed during Setup.

With Pre-Set # [≐21] showing in the mAs Display, select the Maximum kVp. The choices are 99 kVp, 125 kVp (V10-/20/30) and 150 kVp (V-40/50). This selection represents the Maximum kVp the Operator will be permitted to select on the Operator's Console during normal operation.

### Rotor Speed

You must select the Rotor Speed.

By selecting (50) for Pre-Set # [≐22] you configure the generator for 50Hz, Low Speed operation. In this configuration Pre-Set # [≐23] becomes a display of Rotor Boost Time.

By selecting (60) for Pre-Set # [≐22] you configure the generator for 60Hz, Low Speed operation. In this configuration Pre-Set # [≐23] becomes a display of Rotor Boost Time.

By selecting (180) for Pre-Set # [≐22] you configure the generator for High Speed operation. In this configuration Pre-Set # [≐23] has no function.



**CAUTION: If you select (180) for Pre-Set# [≐22] you must have an External High Speed Starter connected to the AEC/HSS option pcb and the rotor connections must terminate in the External High Speed Starter, not on J9 of the SPB pcb.**

## Low Speed Boost Time

When you press the PREP push-button there is a delay before the green PREP LED illuminates.

This delay is the Rotor Boost Time.

During this time the rotor is accelerated to approximately 3600 RPM, the filament is boosted to the correct temperature, all the interlocks are checked (including the rotor interlock) and the Pre-Charge and Charge sequences are initiated.

If you have selected (50) or (60) for Pre-Set# [=22], you may select a Rotor Boost Time.

Using the Up/Down push-buttons for the mAs Display, scroll through the Pre-Set #s until you have [=23] displayed on the mAs Display.

The Factory Setting for this Pre-Set # is [1.7] sec.

Select a value for Rotor Boost Time.



**NOTE: The minimum value is [1.7] sec. This is the minimum time necessary for the filament temperature to stabilize when changing from Standby to the mA Station selected for exposure.**

### Interlock Selection

The generator provides for two independent interlocks with LED Displays on the Operator's Console.

They are Collimator Interlock and Door Interlock. In addition, there is a Thermal Interlock for the X-Ray Tube.



**NOTE: For Tube Thermal Interlock, Collimator Interlock, and Door Interlock you have two choices on the Time Display; [0] or [1]. [0] = disabled, [1] = enabled.**

### Tube Thermal Interlock

If you have connected a Thermal Interlock for the X-Ray Tube to J9, pin 9 on the SPB pcb (refer to Figure 3-5) select a [1] for Pre-Set # [=24]. If not select a [0].

### Collimator Interlock

If you have connected a Collimator Interlock to J4, pin 5 on the BBU pcb (refer to Figure 3-7) select a [1] for Pre-Set # [=25]. If not select a [0].

### Door Interlock

If you have connected a Door Interlock to J4, pin 6 on the BBU pcb (refer to Figure 3-7) select a [1] for Pre-Set # [=26]. If not select a [0].

### Software Version

Pre-Set # [=27] will indicate the Software Version of the generator.



**NOTE: This completes the Setup section of the Technical Manual. Advance the Pre-Set # showing in the mAs Display to [=32] and turn to Chapter 5: Calibration.**

Chapter 5: Calibration

 **WARNING:** The procedures detailed in this chapter will produce tube current. Do not proceed unless you have completed the steps outlined in Chapter 4: Setup. Failure to heed this WARNING may result in catastrophic failure of the X-Ray Tube, serious damage to the generator and possible injury.

 **NOTE:** You should be in the SERVICE Mode with Pre-Set # [=32] showing in the mAs Display on the Operator's Console.

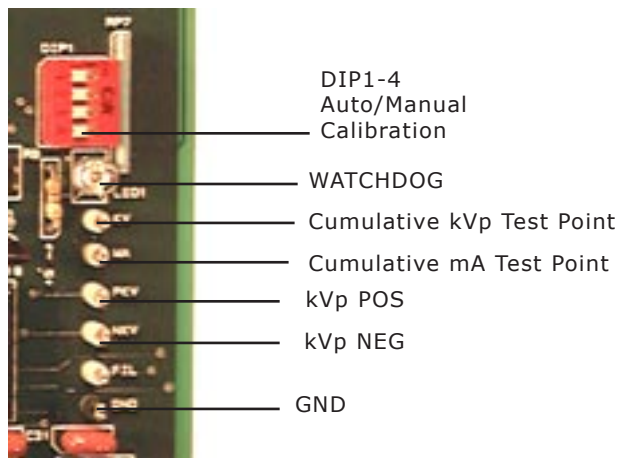

Figure 5-1 kVp, mA Test Points

kVp Cumulative	1 V = 32 kVp
kVp Anode	1 V = 28 kVp
kVp Cathode	1 V = 28 kVp
mA Cumulative	1 V = 133 mA

Monitor the kVp POS and kVp NEG test points with a dual trace, storage oscilloscope for these procedures (refer to Figure 5-1). Select 1 V/division and 10 ms.

kVp Feedback Test

The first step in the Calibration Procedure is to ensure that the kVp Feedback loop is connected correctly and working properly.

 **WARNING:** Do not omit this procedure when initiating a Calibration Sequence. Catastrophic damage to the High Voltage components of the generator could occur.

 **NOTE:** The technique factors for the following series of exposures are automatically adjusted by the software.

 **WARNING: DANGER:** When the wall disconnect is switched on, 208 VAC stand-by power is present on the SPB pcb even if the Operator's Console is switched off. Lethal voltages are present on the pcb and care should be taken to avoid electrical shock.

During this test the Time Display will indicate the DC Voltage charge on the Storage Capacitors and the kVp Display will show the test kVp. With Pre-Set # [≡32] showing on the mAs Display of the Operator's Console, the capacitor voltage level [100] will be showing on the Time Display. The kVp Display will show the kVp value for the test (50 kVp).

With Pre-Set # [≡32] showing on the mAs Display of the Operator's Console, press and hold the PREP push-button.

The following sequence of events will be initiated:

The Discharge Relay will be disabled.

The Pre-Charge Relay will be energized momentarily until approximately 100 VDC is indicated on the storage capacitors.

The Charge Relay will be disabled.

The Rotor will boost and begin to run.

The green Ready LED in the PREP push-button will illuminate.

Press the EXP push-button and monitor the kVp waveforms on the oscilloscope. The kVp POS should be 25 kVp +/- 5 kVp and the kVp NEG should be 25 kVp +/- 5 kVp.



**NOTE: Only make one exposure. If you must make another exposure for any reason, release the PREP and EXP push-buttons momentarily and start the sequence again.**



**NOTE: During this test there is no tube current. The kVp waveforms will have a long "tail" on them due to slow cable discharge. This is normal.**



**WARNING: If the kVp is not within the limits specified, or if you get an Error Code on the kVp Display of the Operator's Console, do not proceed. This indicates a problem in the kVp Feedback circuitry and must be corrected before any further exposures are made.**

Release the PREP and EXP push-buttons.

If the kVp waveforms are within the limits specified, proceed to Calibration.

## Calibration



**NOTE: During the Calibration Procedure each selected mA station is adjusted at different kVp Set Points. This procedure establishes mA linearity. During calibration, exposures for the higher mA stations will be made at kVp Set Points including 100 kVp, 120 kVp and 140 kVp (V-40/50) regardless of the generator power rating. These exposures are limited to 10 milliseconds and have no relationship to the maximum kW output of the generator.**

The generator has two calibration modes: Manual Calibration and **AUTOCAL**.

In the Manual Calibration mode the Service Engineer selects each programmed mA station and each kVp set point manually. At each of these points he can make exposures and adjust the Filament Number manually.

In the **AUTOCAL** mode the Service Engineer selects each programmed mA station manually and the generator operating system makes exposures and adjusts the Filament Number automatically for each kVp set point.

The generator is shipped in the Manual Calibration mode. DIP1-4 on the BBU pcb is in the OFF position (refer to Figure 5-1). To select the **AUTOCAL** mode, move DIP1-4 to the ON position.

You may switch between Manual Calibration and **AUTOCAL** at any time during the Calibration procedure.



**NOTE:** You should monitor the Cumulative kVp and mA test points during the calibration sequence. Take note of any irregularities in either waveform and note the values indicated.

**CAUTION:** If you encounter any difficulty during the calibration sequence, refer to Chapter 7: Diagnostics for assistance.

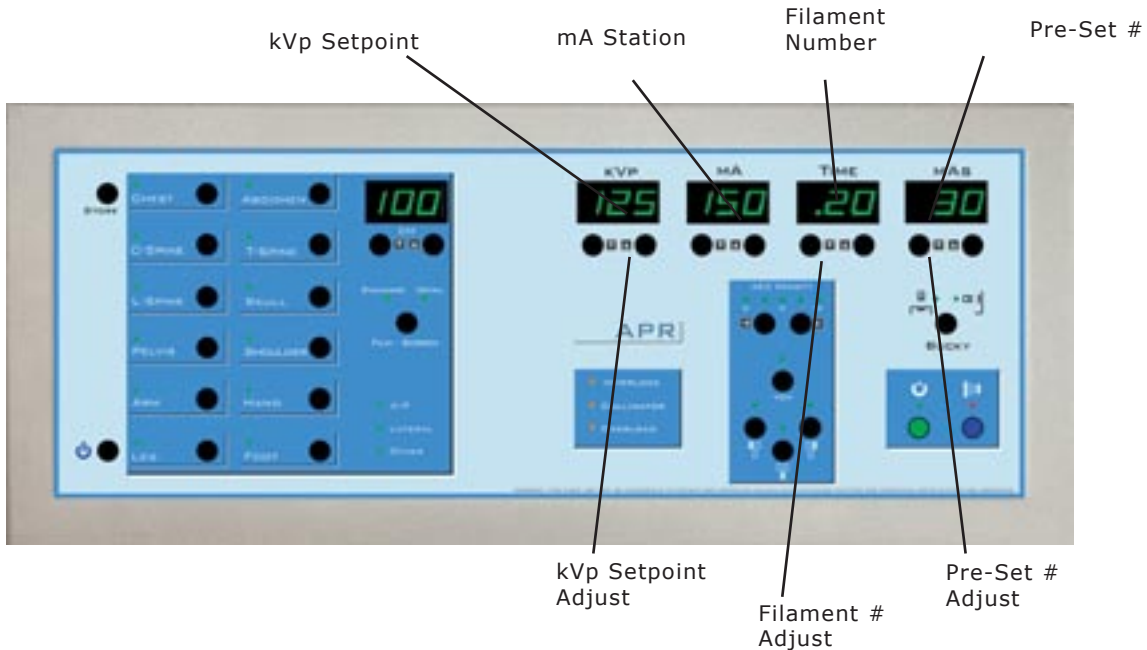

**Figure 5-2a Standard Operator’s Console Calibration Configuration**

Pre-Set #	Description	40 kVp	50 kVp	70 kVp	100 kVp	120 kVp	140 kVp
33	25 mA Station						
34	50 mA Station						
35	75 mA Station						
36	100 mA Station						
37	150 mA Station						
38	200 mA Station						
39	250 mA Station						
40	300 mA Station						
41	400 mA Station						
42	500 mA Station						
43	600 mA Station						

Table 5-1 Calibration Pre-Set #s



**NOTE: The filament numbers in all the kVp Set Point locations for the mA stations were entered during Final Test at the factory. Your numbers will be different for the x-ray tube you are calibrating.**

mA Station	mA Test Point Voltage	mA Station	mA Test Point Voltage
25 mA	0.19	250 mA	1.88
50 mA	0.38	300 mA	2.25
75 mA	0.56	400 mA	3.00
100 mA	0.75	500 mA	3.75
150 mA	1.13	600 mA	4.50
200 mA	1.50		

**Table 5-2 Voltage Readings at mA Composite Test Point on DIB for each mA Station**

## Manual Calibration

The Manual Calibration mode provides for manual selection of each mA station and kVp set point and manual adjustment of the Filament Numbers for each programmed mA station to produce the correct mA.

Tube Protection is automatic and is based upon the selection of the x-ray tube in Pre-Set # [=00]. **Press the SERVICE pushbutton on the BBU pcb to put the generator into the SERVICE mode.**

Using the Up/Down push-buttons for the mAs Display, advance the Pre-Set # until you have the first programmed mA station displayed on the mAs Display. (Refer to Table 5-1.) The Time Display will show the Filament Number.



**NOTE: The range of Filament Numbers is 0 to 999, depending upon the size of the filament.**

The kVp Display will show the first kVp set point (refer to Figure 5-2). The mA Display will show the mA Station.

Press and hold the PREP push-button. When the green READY LED is illuminated make an exposure by pressing the EXP push-button.

Adjust the Filament Number (up or down as required) and make another exposure and read the mA.

Continue until you have completed calibration for this mA station on all the kVp set points.

Using the Up/Down push-buttons for the mAs Display advance to the next Pre-Set # corresponding to the next programmed mA station. (Refer to Table 5-1).

Adjust the Filament Number for each kVp set point in turn until you have completed calibration for this mA station.

Continue until you have adjusted the correct mA for each mA station and each kVp set point programmed.

## AUTOCAL

The AUTOCAL mode provides for manual selection of each programmed mA station and automatic adjustment of the Filament Numbers at each kVp set point to produce the correct mA.

The generator is shipped in the Manual Calibration mode. DIP1-4 on the BBU pcb is in the OFF position (refer to Figure 5-1).

To select the AUTOCAL mode, move DIP1-4 to the ON position. **Press the SERVICE pushbutton on the BBU pcb to put the generator into the SERVICE mode.**

Tube Protection is automatic and is based upon the selection of the x-ray tube in Pre-Set # [=00].

Using the Up/Down push-buttons for the mAs Display, advance the Pre-Set # until you have the first programmed mA station displayed on the mAs Display. (Refer to Table 5-1.)

The Time Display will show the Filament Number.



**NOTE: The range of Filament Numbers is 0 to 999, depending upon the size of the filament.**

The kVp Display will show the first kVp set point (refer to Figure 5-2). The mA Display will show the mA Station

Press and hold the PREP push-button. When the green READY LED is illuminated, press and hold the EXP push-button.

The generator will begin a series of exposures controlled by the operating system. The mA value will be sampled and the Filament Number will be adjusted up or down as required.

This process will continue until the correct mA level is reached for the selected kVp set point.

The generator will then select the next kVp set point and continue the process.

This will continue (as long as the PREP and EXP push-buttons are pressed) until the mA value at the last kVp set point is correct.

The generator will stop making exposures.

Release the PREP and EXP push-buttons and select the next programmed mA station by using the Up/Down push-buttons for the mAs Display.

Press and hold the PREP and EXP push-buttons to begin the AUTOCAL sequence for the selected mA station.

Continue this process until you have completed the AUTOCAL sequence for each programmed mA station.



**WARNING: During the calibration procedure (Manual or AUTOCAL) the generator is monitoring % Heat Units in the anode of the x-ray tube. When the % Heat Units reaches 85% a pulsed tone will sound continuously. Exposures are prohibited while this tone is sounding. Should you reach 85% Heat Units during the calibration procedure for the particular x-ray tube you are using, take a 15 minute time-out to allow the anode to dissipate the accumulated heat.**

## AEC Density Adjust

Each Ion Chamber connected to generator can be adjusted independently for density and skew.

There are 6 Pre-Set #s associated with the AEC Density Adjust procedure, 2 for each Ion Chamber. (Refer to Table 5-3.)



**NOTE: AEC is active only if the specific option is installed.**



**NOTE: The Pre-Set #s indicated in Table 5-3 will not be active unless you selected a [1] for Pre-Set#s [≐17], [≐18], [≐19] in Chapter 4: Setup.**

The following procedure applies to each Ion Chamber connected to the generator.

Select 80 kVp, and a Back-Up Time. Select an mA station appropriate for the density phantom you use.

Select 0 Density on the Operator's Console and Bucky 1, Bucky 2 or No Bucky as appropriate.

Make an exposure and read the density of the film.



**NOTE: You cannot make an exposure in the Service Mode with one of the AEC Pre-Set #s showing on the Time Display. You must exit the Service Mode to make the exposure and re-enter the Service Mode to make density and skew adjustments.**

### Density

Adjust Master Pot on Ion Chamber Up or Down as needed and Make Exposures until you have the desired Density at 80 kVp.

### Tilt

Make an Exposure at 50 kVp and 100 kVp and read the Density. Adjust the Tilt Number until you have the same Density at 50 kVp, 80 kVp, and 100 kVp.



**NOTE: The Tilt Number cannot be less than the Density Number nor more than twice the Offset Number.**



**NOTE: The maximum number for Tilt is 250.**

Pre-Set #	Description	Factory Setting	Notes
4 4	No Bucky AEC Density	100	
4 5	No Bucky AEC Tilt	100	
4 6	Bucky 1 AEC Density	100	
4 7	Bucky 1 AEC Tilt	100	
4 8	Bucky 2 AEC Density	100	
4 9	Bucky 2 AEC Tilt	100	

Table 5-3 AEC Pre-Set #s

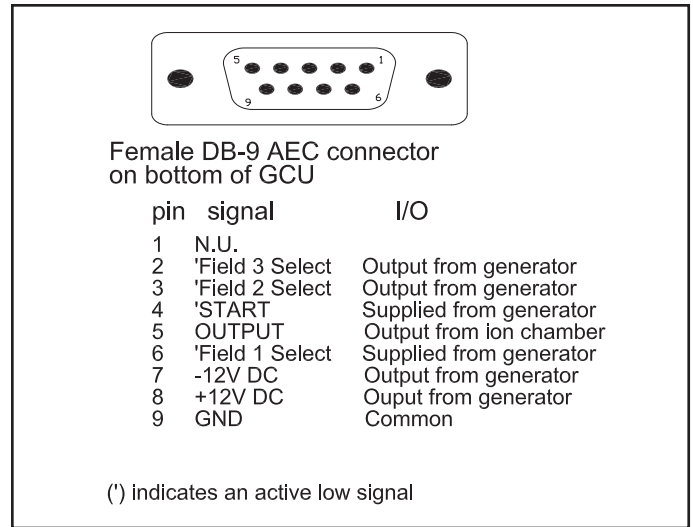

Figure 5-3 Pinout for AEC Connectors

 **NOTE: For Use With Positive Slope ION Chambers Only**

## Chapter 6: Compliance Testing

### Overview

The generator meets the requirements for DHHS Radiation performance standards for high voltage generators as detailed in Title 21 CFR, Chapter 1, Sub Chapter J, Section 1020 in effect as of the date of manufacture.

This chapter details the procedures necessary to ensure compliance with the performance standard.

The tests and inspections in this chapter should be performed:

Upon initial installation

Once a year as part of a preventive maintenance inspection

Any time a major component is replaced



**CAUTION: The generator is a sophisticated electronic device. All components are chosen for performance, quality and safety. Replacement should be confined to printed circuit boards or major components. Replacement of components other than those mounted in a socket (i.e. fuse, relay,) on a printed circuit board is not authorized as this may affect safety as well as performance standard compliance.**

### Configuration

Operator's Console

There are 2 Operator's Consoles that are available with the VALUEGEN® family of generators that require Compliance Testing.

They are:

Standard Operator's Console (Part Number 6065.00)

APR Operator's Console (Part Number 6072.00)

## Standard Operator's Console

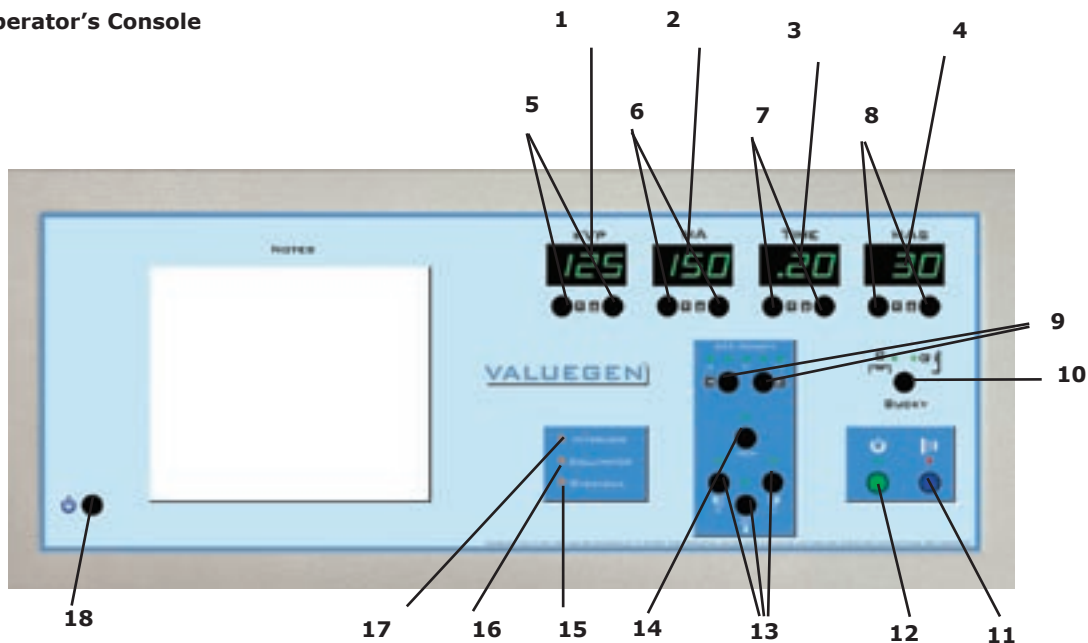

Figure 6-1A Standard Operator's Console (Front View)

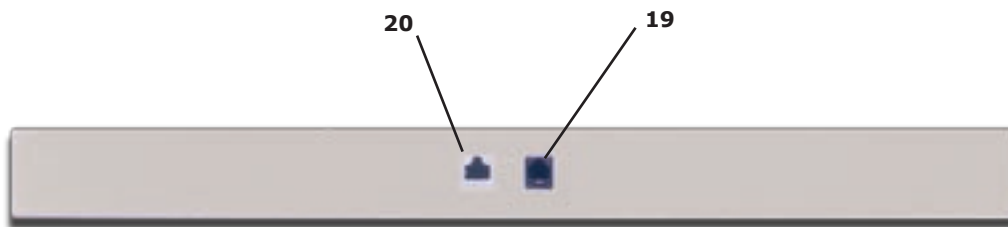

Figure 6-1B Standard Operator's Console (Rear View)

- |                        |                      |
|------------------------|----------------------|
| 1. kVp Display         | 11. EXP              |
| 2. mA Display          | 12. PREP             |
| 3. Time Display        | 13. AEC Field Select |
| 4. mAs Display         | 14. AEC Reset        |
| 5. kVp Up/Down         | 15. Overload LED     |
| 6. mA Up/Down          | 16. Collimator LED   |
| 7. Time Up/Down        | 17. Interlock LED    |
| 8. mAs Up/Down         | 18. On/Off           |
| 9. AEC Density Up/Down | 19. Hand Switch      |
| 10. BKY Select         | 20. Connector        |



**NOTE: Based upon selections made in Chapter 4: Setup, some of the following tests may not be applicable.**

Refer to Figure 6-1A&B for the following tests.

**On/Off**

Press and release the On/Off push-button [18] on the Operator's Console .

The system should come on and all LEDs in the four displays should illuminate and the Beep should sound.

There should not be an Error Code displayed in the kVp Display.

**kVp Display and Up/Down**

There should be a value between 40 and 125 displayed on the kVp Display [1].

Press kVp Up and kVp Down [5]. The display should increase and decrease.

**mA Display and Up/Down**

There should be an mA value showing on the mA Display [2].

Press mA Up and mA Down [6]. The display should increase and decrease. The decimal point in the lower right of the display will illuminate to indicate Large Focal Spot.

**Time Display and Up/Down**

There should be a Time value showing on the Time Display [3].

Press Time Up and Time Down [7]. The display should increase and decrease. The decimal point will change to indicate milliseconds, tenths and whole seconds.

**mAs Display and Up/Down**

There should be an mAs value showing on the mAs Display [4].

Press mAs Up and mAs Down [8]. The display should increase and decrease. The decimal point will change to indicate portions or whole mAs.

**Interlock LED**

Open the external interlock connected to Pin 6 of J4 on the BBU pcb.

The Interlock LED [17] should be illuminated and PREP should be inhibited.

Close the Interlock.

The Interlock LED [17] should not be illuminated and PREP should be functional.

**Collimator LED**

Open the collimator interlock connected to Pin 5 of J4 on the BBU pcb.

The Collimator LED [16] should be illuminated and PREP should be inhibited.

Close the Interlock

The Collimator LED [16] should not be illuminated and PREP should be functional.

**Overload LED**

Increase the kVp, mA and Time to the maximum indications for each display.

Observe the Overload LED [15].

If the exposure factors selected exceed the maximum ratings for the x-ray tube selected, this LED should be illuminated and PREP should be inhibited.

**PREP**

Press and hold PREP [12].

The rotor should turn and after the programmed Rotor Boost Time, the green PREP LED should illuminate indicating an exposure is possible.

**EXP**

Select 50 kVp, the smallest mA programmed and 1.0 sec Time.

Press and hold PREP [12].

When the green PREP LED illuminates, press and hold EXP [11].

The red EXP LED should illuminate and an audible tone should sound to indicate an exposure in progress.

Release EXP before the selected time expires.

The exposure should stop, the red EXP LED should extinguish and the audible tone should stop.

Press and hold EXP again.

Another exposure should begin.

At the end of the selected time the exposure should stop.

Release PREP and EXP.

Press and hold EXP only.

There should be no indication and no exposure.

**BKY****Bky 1**

Press the BKY switch [10] until the Bky 1 LED is illuminated.  
Select 50 kVp, the smallest mA station programmed and .25 secs on the Time Display.  
Make an exposure and observe the Bucky connected to Bky 1.  
The Bucky should oscillate and the exposure should occur normally.

**Bucky 2**

Press the BKY switch [10] until the Bky 2 LED is illuminated.  
Select 50 kVp, the smallest mA station programmed and .25 secs on the Time Display.  
Make an exposure and observe the Bucky connected to Bky 2.  
The Bucky should oscillate and the exposure should occur normally.

**No Bucky**

Press the BKY switch [10] until the Bky 1 and Bky 2 LEDs are not illuminated.  
Select 50 kVp, the smallest mA station programmed and .25 secs on the Time Display.  
Make an exposure and observe the Buckys connected to the generator.  
The Buckys should not oscillate and the exposure should occur normally.

**AEC Density**

One of the LEDs in the AEC Density Display should be illuminated.  
Press AEC Density Up and AEC Density Down [9].  
The LEDs should indicate a full range between -2 to +2 Density.

**AEC Reset/600 MAS Limit**

Select 50 kVp, the maximum mA programmed and a backup Time to exceed 600 MAS. (i.e. if 300 mA then 2.5 sec)



**NOTE: If your x-ray tube will not allow a technique that will exceed 600 MAS, ignore this step.**

Close the collimator.  
Make an exposure and observe that the AEC Reset LED illuminates and flashes.  
While flashing, PREP and EXP are inhibited.  
Press the AEC Reset push-button [14] and the LED ceases to flash and is extinguished.

**AEC Field Select**

Press and release FIELD (13) switches to select or de-select the appropriate field. The LEDs will illuminate to indicate field selection.



**APR Operator's Console**

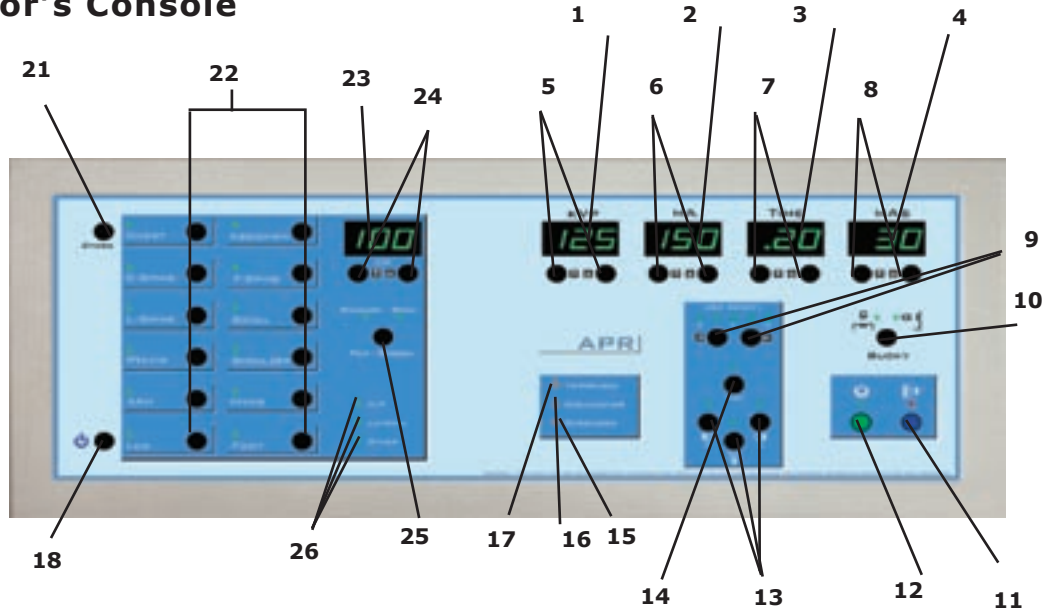

**Figure 1-1A APR Operator's Console (Front View)**

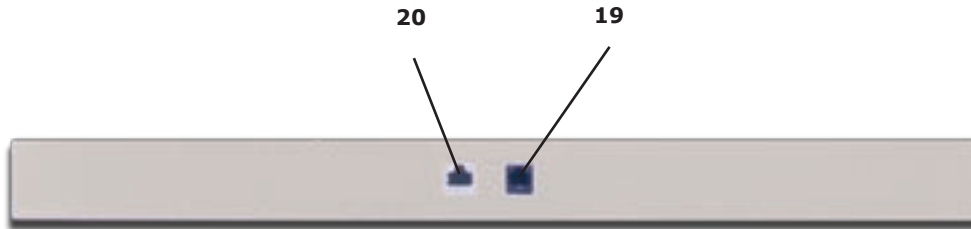

**Figure 1-1B APR Operator's Console (Rear View)**

- |                        |                      |                        |
|------------------------|----------------------|------------------------|
| 1. kVp Display         | 10. BKY Select       | 19. Hand Switch        |
| 2. mA Display          | 11. EXP              | 20. Connector          |
| 3. Time Display        | 12. PREP             | 21. Store              |
| 4. mAs Display         | 13. AEC Field Select | 22. APR Selections     |
| 5. kVp Up/Down         | 14. AEC Reset        | 23. Centimeter Display |
| 6. mA Up/Down          | 15. Overload LED     | 24. Centimeter Up/Down |
| 7. Time Up/Down        | 16. Collimator LED   | 25. Film/Screen Select |
| 8. mAs Up/Down         | 17. Interlock LED    | 26. A/P-Lateral-Other  |
| 9. AEC Density Up/Down | 18. On/Off           |                        |



**NOTE: Based upon selections made in Chapter 4: Setup, some of the following tests may not be applicable.**

Refer to Figure 6-1A&B for the following tests.

**On/Off**

Press and release the On/Off push-button [18] on the Operator's Console .

The system should come on and all LEDs in the five displays should illuminate and the Beep should sound.

There should not be an Error Code displayed in the kVp Display.

**kVp Display and Up/Down**

There should be a value between 40 and 125 displayed on the kVp Display [1].

Press kVp Up and kVp Down [5]. The display should increase and decrease.

**mA Display and Up/Down**

There should be an mA value showing on the mA Display [2].

Press mA Up and mA Down [6]. The display should increase and decrease. The decimal point in the lower right of the display will illuminate to indicate Large Focal Spot.

**Time Display and Up/Down**

There should be a Time value showing on the Time Display [3].

Press Time Up and Time Down [7]. The display should increase and decrease. The decimal point will change to indicate milliseconds, tenths and whole seconds.

**mAs Display and Up/Down**

There should be an mAs value showing on the mAs Display [4].

Press mAs Up and mAs Down [8]. The display should increase and decrease. The decimal point will change to indicate portions or whole mAs.

**Interlock LED**

Open the external interlock connected to Pin 6 of J4 on the BBU pcb.

The Interlock LED [17] should be illuminated and PREP should be inhibited.

Close the Interlock.

The Interlock LED [17] should not be illuminated and PREP should be functional.

**Collimator LED**

Open the collimator interlock connected to Pin 5 of J4 on the BBU pcb.

The Collimator LED [16] should be illuminated and PREP should be inhibited.

Close the Interlock

The Collimator LED [16] should not be illuminated and PREP should be functional.

**Overload LED**

Increase the kVp, mA and Time to the maximum indications for each display.

Observe the Overload LED [15].

If the exposure factors selected exceed the maximum ratings for the x-ray tube selected, this LED should be illuminated and PREP should be inhibited. PREP

Press and hold PREP [12].

The rotor should turn and after the programmed Rotor Boost Time, the green PREP LED should illuminate indicating an exposure is possible.

**EXP**

Select 50 kVp, the smallest mA programmed and 1.0 sec Time.

Press and hold PREP [12].

When the green PREP LED illuminates, press and hold EXP [11].

The red EXP LED should illuminate and an audible tone should sound to indicate an exposure in progress.

Release EXP before the selected time expires.

The exposure should stop, the red EXP LED should extinguish and the audible tone should stop.

Press and hold EXP again.

Another exposure should begin.

At the end of the selected time the exposure should stop.

Release PREP and EXP.

Press and hold EXP only.

There should be no indication and no exposure.

**BKY**

**Bky 1**

Press the BKY switch [10] until the Bky 1 LED is illuminated.  
 Select 50 kVp, the smallest mA station programmed and .25 secs on the Time Display.  
 Make an exposure and observe the Bucky connected to Bky 1.  
 The Bucky should oscillate and the exposure should occur normally.

**Bucky 2**

Press the BKY switch [10] until the Bky 2 LED is illuminated.  
 Select 50 kVp, the smallest mA station programmed and .25 secs on the Time Display.  
 Make an exposure and observe the Bucky connected to Bky 2.  
 The Bucky should oscillate and the exposure should occur normally.

**No Bucky**

Press the BKY switch [10] until the Bky 1 and Bky 2 LEDs are not illuminated.  
 Select 50 kVp, the smallest mA station programmed and .25 secs on the Time Display.  
 Make an exposure and observe the Buckys connected to the generator.  
 The Buckys should not oscillate and the exposure should occur normally.

**AEC Density**

One of the LEDs in the AEC Density Display should be illuminated.  
 Press AEC Density Up and AEC Density Down [9].  
 The LEDs should indicate a full range between -2 to +2 Density.

**AEC Reset/600 MAS Limit**

Select 50 kVp, the maximum mA programmed and a backup Time to exceed 600 MAS. (i.e. if 300 mA then 2.5 sec)

 **NOTE: If your x-ray tube will not allow a technique that will exceed 600 MAS, ignore this step.**

Close the collimator.  
 Make an exposure and observe that the AEC Reset LED illuminates and flashes.  
 While flashing, PREP and EXP are inhibited.  
 Press the AEC Reset push-button [14] and the LED ceases to flash and is extinguished.

**AEC Field Select**

Press and release FIELD (13) switches to select or de-select the appropriate field. The LEDs will illuminate to indicate field selection.

**Exposure Factor Tests**

kVp/mA

The following tests will determine the accuracy of the three factors involved in an x-ray exposure; kVp, mA and Time.

Monitor the kVp and mA Test Points with a dual trace, storage oscilloscope for the following tests (refer to Figure 6-2).

Select 1 V/division and 10 ms. Monitor the kVp with Channel 1 and the mA with Channel 2. Trigger on Channel 1.

- kVp Cumulative 1 V = 32 kVp
- kVp Anode 1 V = 28 kVp
- kVp Cathode 1 V = 28 kVp
- mA Cumulative 1 V = 133 mA

 **NOTE: The oscilloscope must have a current calibration sticker attached.**

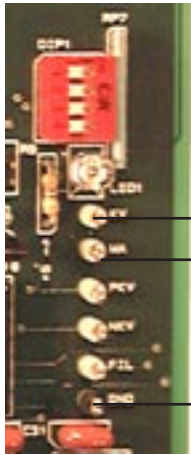

Cumulative kVp Test Point

Cumulative mA Test Point

GND

Figure 6-2 kVp and mA Test Points

Insert the mA stations selected for this installation in Table 6-1.

mA Station	60 kvp	90 kVp	110 kVp	130 kVp
25				
50				
75				
100				
150				
200				
250				
300				
400				X
500			X	X
600		X	X	X

Table 6-1 kVp/mA Measurements

Select the lowest mA station the generator has been programmed for during Setup.  
 Select 60 kVp.  
 Select a time which will allow you to capture the exposure length on the oscilloscope.  
 Make an exposure and record the mA and kVp in Table 6-1.  
 Use the following convention:  
 Select 90 kVp.  
 Make an exposure and record the mA and kVp in Table 6-1.  
 Select 110 kVp.  
 Make an exposure and record the mA and kVp in Table 6-1.

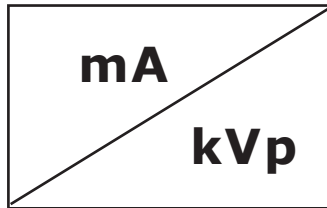

Repeat this procedure for each mA station listed in Table 6-1.

 **NOTE: You may have to change the scale on the oscilloscope at the higher mA values. Take care to read the mA correctly.**

Compare the values you have recorded in Table 6-1 with the following specifications for mA and kVp accuracy.

mA accuracy	+/- 8%	+/- 5 mA
kVp accuracy	+/- 8%	+/- 2 kVp

**Time**

Exposure Time is a function of measuring two corresponding points on the kVp waveform.  
 The exposure time begins at the 75% point on the leading edge of the kVp waveform and ends at the 75% point on the trailing edge of the kVp waveform.

Time Displayed	Time Measured	Time Displayed	Time Measured
.002		.400	
.005		.500	
.008		.600	
.010		.700	
.015		.800	
.020		1.00	
.025		1.50	
.035		2.00	
.050		2.50	
.075		3.00	
.100		3.50	
.125		4.00	
.150		4.50	
.200		5.00	
.250		6.00	
.300			

Table 6-2 Time Measurements

Select 70 kVp, 100 mA , and 2 milliseconds on the Time Display (.002).

Make an exposure and measure the length of the kVp waveform on the oscilloscope.

Record that value in the corresponding box in Table 6-2.

Advance to the next Time station and repeat the procedure.

Continue until you have entered a value for each Time Station in Table 6-2.



**NOTE: As you advance in time you will have to change the time base on the oscilloscope to present the entire kVp waveform on the oscilloscope display.**

Compare the values you have recorded in Table 6-2 with the following specification for Time accuracy.

Time accuracy:

0.002 Sec. to 0.010 Sec.	+/- 0.5 ms
0.015 Sec. to 0.035 Sec.	+/- 1.5 ms
0.050 Sec. to 0.100 Sec	+/- 3.0 ms
0.125 Sec. to 6.0 Sec.	+/- 3%

## Reporting

Report any difficulties you encounter during Compliance Testing to the manufacturer: GTR® LABS, Inc. 510 Elk Street, Gassaway, WV, USA 26624. Telephone 304-364-2211

## Chapter 7: Diagnostics

### Overview

The Self-Diagnostic System of the generator provides accurate, detailed information about the functions of the generator and attached peripheral equipment.

This information is presented in the form of numerical Error Codes.

For the Operator and the Service Engineer, these Error Codes are presented on the kVp Display of the Operator’s Console. A table in the Operator’s Manual as well as the Technical Manual lists the Error Codes which can be displayed and describes the possible cause of the fault and the action the Operator should take.

Refer to Table 7-1 for the Error Codes presented on the kVp Display on the Operator’s Console.

If any of the Error Codes listed in Table 7-1 are showing on the display, refer to the following information for possible causes and suggested corrective action.



Console kVp Display	Description
No Display	Internal GCU Error
E01	Interface Cable
E02	Tube Thermal Interlock
No Display	Communications Error
E03	Bucky Timeout
E04	Rotor Boost Timeout
E05	Rotor Current w/o PREP
E06	Filament Boost Timeout
E07	Bad FIL Current
E08	FIL Current Too High
E09	Cathode kVp Fault (kVp too high)
E10	Anode mA Fault (mA too high)
E11	Anode kVp Fault (kVp too high)
E12	Cathode mA Fault (mA too high)
E13	TEC Fault
E14	IPM #1 Fault
E15	IPM #2 Fault
E16	Setup/Calibration Data Fault
E17	Voltage Monitor Fault
E18	GPU not responding to Console
E19	kVp Drop during exposure
E20	Voltage on capacitors in Standby
E31	%HU over 85%

Table 7-1a Error Codes

 **NOTE: In this section on Error Codes the following abbreviation is used: OPC = kVp Display on the Operator’s Console**

**Error Codes****Error Code: OPC = No Display****Description: Internal GCU Error (No reset)****System Indication:**

Complete lockup of all system functions  
 No Operator's Console  
 No "Watch Dog" indication

**Possible Causes:**

+/- 12 VDC Regulated incorrect or missing  
 Interconnection Ribbon Cables missing or disconnected  
 RAM error on Power Up  
 Ribbon Cable Error

**Corrective Action:**

Check voltage test points on BBU pcb  
 Check fuses on SPB  
 Replace BBU  
 Check Ribbon Cables

Replace Operator's Console

Connect or replace Interconnecting Cable (GCU/  
 Operator's Console)

**Error Code: OPC = E03****Description: No Bucky Motion/Tomo Error (Resets with AEC Reset pressed)****System Indications:**

Error Displayed until corrective action taken  
 No EXP function  
 No "Watch Dog" indication

**Possible Causes:**

No Bucky Motion Signal  
 No Tomo Expose Signal

**Corrective Action:**

Restore Bucky Motion Signal  
 Restore Tomo Expose Signal  
 Deselect Bucky

**Error Code: OPC = E01****Description: Interface Cable Error (Resets on Power Up Sequence)****System Indication:**

No PREP function  
 No "Watch Dog" indication  
 Displayed until corrective action taken

**Possible Causes:**

Disconnect or defective Interface Cable (GCU/  
 HVT)

**Corrective Action:**

Connect or repair Interface Cable (GCU/HVT)

**Error Code: OPC = E04****Description: Rotor Boost Time-out Error (Resets on Power Up Sequence)****System Indication:**

Complete lock up of Operator's Console functions  
 No "Watch Dog" indication  
 Stop PREP sequence in progress  
 Disconnects 208 VAC Switched on SPB

**Possible Causes:**

No Rotor current during PREP  
 Open MAIN or Phase Rotor Wires

**Corrective Action:**

Restore Rotor current

**Error Code: OPC = E02****Description: Tube Thermal Interlock (Resets when Tube cools)****System Indication:**

No PREP function  
 No "Watch Dog" indication  
 Displayed until corrective action taken

**Possible Causes:**

X-Ray Tube overheated

**Corrective Action:**

Wait until X-ray Tube Cools

**Error Code: OPC = No Display****Description: Communications Error (No Reset)****System Indications:**

Complete lockup of all system functions  
 Possible no Operator's Console  
 No "Watch Dog" indication

**Possible Causes:**

Failure of Operator's Console  
 Disconnected or defective Interconnecting Cable  
 (GCU/Operator's Console)

**Corrective Action:****Error Code: OPC = E05****Description: Rotor Current without PREP Error (Resets on Power Up Sequence)****System Indication:**

Complete lock up of Operator's Console functions  
 No "Watch Dog" indication  
 Disconnects 208 VAC Switched on SPB

**Possible Causes:**

Failure in Rotor Boost circuit  
 Rotor Relay stuck

**Corrective Action:**

Restore normal Rotor function  
 Replace SPB pcb

**Error Code: OPC = E06****Description: Filament Boost Time-out Error (Resets on Power Up Sequence)****System Indication:**

Complete lock up of Operator's Console functions



No "Watch Dog" indication  
 Stops PREP Sequence in progress  
 Disconnects 208 VAC Switched on SPB

Possible Causes:

Failure in Filament circuit  
 X-Ray Tube  
 Incorrect or missing Calibration numbers for selected mA

Corrective Action:

Restore Filament Current  
 Check Calibration numbers. Recalibrate if necessary.

**Error Code: OPC = E07**

**Description: No FIL I Error (Reset when FIL I restored)**

System Indication:

Complete lock up of Operator's Console functions  
 No "Watch Dog" indication  
 Disconnects 208 VAC Switched on SPB

Possible Causes:

Open Small or Large Filament  
 Defective TEC PCB  
 Defective BBU PCB

Corrective Action:

Check Filament Continuity in tube, Cathode Cable, Input / Output Filament Transformer  
 Replace TEC PCB  
 Replace BBU PCB

**Error Code: OPC = E08**

**Description: FIL I Too High Error (Resets on Power Up Sequence)**

System Indication:

Complete lock up of Operator's Console functions  
 No "Watch Dog" indication  
 Stop PREP sequence in progress  
 Disconnects 208 VAC Switched on SPB

Possible Causes:

Calibration Off

Corrective Action:

Recalibrate

**Error Code: OPC = E09**

**Description: Cathode Fault (kVp Too High) (Resets on Power Up Sequence)**

System Indication:

Stop EXP in progress  
 Complete lock up of Operator's Console functions  
 No "Watch Dog" indication  
 Disconnects 208 VAC Switched on SPB

Possible Causes:

High Voltage Arc on Anode side  
 Defective X-Ray Tube  
 Defective High Voltage Cable  
 Failure in HVT

Corrective Action:

Inspect for visual evidence of High Voltage Arc  
 Inspect/Replace X-Ray Tube  
 Inspect/Replace High Voltage Cables  
 Inspect/Replace HVT

**Error Code: OPC = E10**

**Description: Anode Fault (mA Too High) (Resets on Power Up Sequence)**

System Indication:

Stop EXP in progress  
 Complete lock up of Operator's Console functions  
 No "Watch Dog" indication  
 Disconnects 208 VAC Switched on SPB

Possible Causes:

Filament Numbers Too High

Corrective Action:

Lower Filament Numbers - Recalibrate

**Error Code: OPC = E11**

**Description: Anode Fault (kVp Too High) (Resets on Power Up Sequence)**

System Indication:

Stop EXP in progress  
 Complete lock up of Operator's Console functions  
 No "Watch Dog" indication  
 Disconnects 208 VAC Switched on SPB

Possible Causes:

High Voltage Arc on Cathode side  
 Defective X-Ray Tube  
 Defective High Voltage Cable  
 Failure in HVT

Corrective Action:

Inspect for visual evidence of High Voltage Arc  
 Inspect/Replace X-Ray Tube  
 Inspect/Replace High Voltage Cables  
 Inspect/Replace HVT

**Error Code: OPC = E12**

**Description: Cathode Fault (mA Too High) (Resets on Power Up Sequence)**

System Indication:

Stop EXP in progress  
 Complete lock up of Operator's Console functions  
 No "Watch Dog" indication  
 Disconnects 208 VAC Switched on SPB

Possible Causes:

High Voltage Arc on Anode side  
 Defective X-Ray Tube  
 Defective High Voltage Cable  
 Failure in HVT

Corrective Action:

Inspect for visual evidence of High Voltage Arc  
 Inspect/Replace X-Ray Tube  
 Inspect/Replace High Voltage Cables  
 Inspect/Replace HVT

**Error Code: OPC = E13**

**Description: TEC pcb Fault Error (Resets on Power Up Sequence)**

System Indication:

Complete lock up of Operator's Console functions  
 No "Watch Dog" indication  
 Disconnects 208 VAC Switched on SPB

Possible Causes:

Loss of Switched 208 VAC From SPB PCB  
 Blown Fuse F-3

Corrective Action:

Replace Fuse F-3

**Error Code: OPC = E14**

**Description: IPM 1 Fault Error (Resets on Power Up Sequence) Ensure Ribbon Cable for IPM 1 to J6 on IOP pcb.**

System Indication:

Stops EXP in progress  
 Disconnects 208 VAC Switched on SPB  
 Complete lock up of Operator's Console functions  
 No "Watch Dog" indication

Possible Causes:

AC Line weak or collapsed (below 187 VAC)  
 Excessive current through IPM 1

Corrective Action:

Check IPM 1 for short circuit (Replace both IPM 1 and the IPM Driver pcb)  
 Call Factory

**Error Code: E16**

**Description: Setup/Calibration Data Incorrect (Will not reset)**

System Indication:

Checked on Power Up Sequence only  
 Complete lockup of Operator's Console  
 No "Watch Dog" indication

Possible Causes:

Setup/Calibration Data Missing or corrupted  
 Defective BBU pcb

Corrective Action:

Follow detailed procedure listed below  
 If the problem recurs, replace BBU pcb



**NOTE: If you have this Error Code showing on the Operator's Console, the generator is disabled until you perform the following procedure. With this Error Code, the SERVICE switch on the BBU pcb will not function.**

If Error Code E16 appears on Start Up;

1. Turn off the generator
2. Turn off the Wall Disconnect
3. Press and hold the Service Push Button on the BBU pcb and turn on the Wall Disconnect
4. Hold the Service Push Button for approximately 2 seconds then release.
5. When the Blue Watch Dog LED goes out, turn on the generator.



**WARNING: At this point you will have returned all of the Setup Locations to their factory default settings including calibration. Do not attempt to make an exposure until you have completed the steps detailed in Chapter 4 and Chapter 5. Failure to follow this WARNING may result in damage to the equipment and/or failure of the x-ray tube.**

6. Press the Service Push Button on the BBU pcb. You will now be in the SERVICE Mode. All of the Setup Locations will be reset to Factory Default values. You must

complete all of the steps in Chapter 4, Setup and calibrate the generator according to instructions in Chapter 5, Calibration.

7. Exit the SERVICE Mode by pressing the Service Push Button on the BBU pcb. The generator should return to normal operation with no error codes displayed on the Operator's Console.

**Error Code: OPC = E17**

**Description: Voltage Monitor Fault Error (Resets on Power Up Sequence)**

System Indication:

Complete lock up of Operator's Console functions

No "Watch Dog" indication

Disconnects 208 VAC Switched on SPB

Possible Causes:

Failure in Pre-Charge circuit

Failure in Charge circuit

No Voltage on Buss at End of Prep

Corrective Action:

Replace Charge Resistor

Replace SPB PCB

Shorted IPM

IPM Driver OptoCoupler Failure

Flux Capacitor Failure

Corrective Action:

Look for bubbles in X-Ray Tube oil

Check Cable Wells (Tube and Transformer)

Check IPMs (Remove output leads and check with ohmmeter from output terminal to each of the other two terminals).

Replace IPM Driver

Replace Flux Capacitor

**Error Code: OPC = E20**

**Description: Voltage on Capacitors in Stand By (Resets on Power Up Sequence)**

System Indication:

Complete lock up of Operator's Console functions

No "Watch Dog" indication

Prohibit Exposure Sequence

Possible Causes:

Defective SPB pcb

Corrective Action:

Replace SPB pcb

**Error Code: OPC = E18**

**Description: GPU Not Responding Error (Will not reset)**

System Indication:

Complete lock up of Operator's Console functions

No "Watch Dog" indication

Possible Causes:

BBU pcb Failure

+/- 12 VDC Regulated incorrect or missing

+ 5 VDC Regulated incorrect or missing

Corrective Action:

Replace BBU pcb

Check voltage test points on BBU pcb

Check fuses on SPB

Replace SPB pcb

**Error Code: OPC = E31**

**Description: % HU over 85% (Resets on Power Up Sequence)**

System Indication:

Complete lock up of Operator's Console functions

No "Watch Dog" indication

Prohibit Exposure Sequence

Possible Causes:

X-Ray Tube Anode overheated

Corrective Action:

Wait for X-Ray Tube Anode to Cool

**Error Code: OPC = E19**

**Description: kVp Drop During Exposure (Resets on Power Up Sequence)**

System Indication:

Complete lock up of Operator's Console functions

No "Watch Dog" indication

If you monitor with an oscilloscope you will observe that the selected kVp is correct at the beginning of the exposure but drops several milliseconds into the exposure to 50 or less.

Possible Causes:

High Impedance Short in X-Ray Tube

Carbon Track in Cable Wells (Tube or Transformer)

**Error Code: OPC = E32**

**Description: Sync Missing or Incorrect (Resets on Power Up Sequence)**

System Indication:

Complete lock up of Operator's Console functions

No "Watch Dog" indication

Prohibit Exposure Sequence

Possible Causes:

Defective SPB pcb

Corrective Action:

Replace SPB pcb

## Trouble-Shooting Tips

This section contains information to assist the service technician in trouble-shooting the generator.

The information presented is in order of descending importance. The most likely cause is first and the next likely cause is second, etc.



**NOTE: The "Possible Causes" and "Corrective Actions" mentioned in this section DO NOT represent all of the factors that may apply to any given situation presented here.**

### System will not come on when On/Off pushbutton on the Operator's Console is pressed.

Possible Causes:

- Incorrect or missing 208 VAC applied to GCU
- Blown Fuses 208 VAC on SPB pcb
- Incorrect or missing +12 VDC from SPB pcb
- Blown Fuse +12 VDC from SPB pcb
- Incorrect or missing +5 VDC Regulated from SPB pcb
- Blown Fuse + 5 VDC Regulated on SPB pcb
- Interconnecting cable missing or defective (GCU/ Operator's Console)
- Defective BBU pcb
- Defective Operator's Console

### IPM Fault occurs at higher KW settings only.

Possible Causes:

- Low 208 VAC Line Voltage
- AC Line Collapse during exposure

## Parts List

PART NUMBER	DESCRIPTION
4001	TEC pcb
4034	IPM Driver pcb
4032	SPB pcb
	Option pcb
4033	Brain Board pcb
6002	HV TANK (V-10/20/30/40)
6046	Operator's Console
6048	HV Tank (V-50)
8610	Pre-Charge Resistor
8612	Discharge Resistor
10520	3900mfd (V-10/20/30)
10521	4700mfd Capacitor (V-40/50)
10950	Flux Capacitor
10951	Rotor Capacitor
11002	IPM Snubber
12020	3 Phase Bridge (V-40/50)
12025	1 Phase Bridge (V-10/20/30)
18164	400A IPM (V-10/20/30)
18165	600A IPM (V-40/50)
23600	3 Phase Charge Relay (V-40/50)
23610	1 Phase Charge Relay (V-10/20/30)
31120	Line Fuse

Figure S-1 Parts List

## Acronyms

BB	Brain Board	DSP Processing
GCU	Generator Control Unit	The chassis housing the electronics for the generator
HVT	High Voltage Transformer	Source of High Voltage and Filament Supply for the x-ray tube
IPM	Intelligent Power Module	High Frequency Switching Module which includes the IPM Driver pcb
SPB	System Power Board	Provides interface for 208 VAC, Charge and Discharge and Rotor
TEC	Thermionic Emission Controller	Source of supply for x-ray tube filament

Figure S-2 Acronym Chart