



# *Service manual*

*Room airconditioner*

*Split Wall-Mounted Type*



*Applied to:*

MSV1-09HRDN1

MSV1-12HRDN1

## NOTE:

---

Before servicing the unit, please read this at first.  
Always contact with your service center if meet problem.

# Content

<b>1.</b>	<b>Precaution .....</b>	<b>1</b>
1.1	Safety Precaution .....	1
1.2	Warning .....	1
<b>2.</b>	<b>Function.....</b>	<b>3</b>
<b>3.</b>	<b>Dimension.....</b>	<b>5</b>
3.1	Indoor unit (Vertu) .....	5
3.2	Outdoor unit (Vertu) .....	5
<b>4.</b>	<b>Specification.....</b>	<b>6</b>
<b>5.</b>	<b>Refrigerant cycle diagram .....</b>	<b>7</b>
<b>6.</b>	<b>Operation limits.....</b>	<b>8</b>
6.1	Cooling operation.....	8
6.2	Heating operation .....	8
<b>7.</b>	<b>Schematic diagram and Wiring diagram.....</b>	<b>9</b>
7.1.	Schematic diagram .....	9
7.2.	Wiring diagram .....	13
<b>8.</b>	<b>Installation details .....</b>	<b>14</b>
8.1	Wrench torque sheet for installation .....	14
8.2	Connecting the cables .....	14
8.3	Pipe length and the elevation .....	14
8.4	Air purging of the piping and indoor unit .....	15
8.5	Pumping down (Re-installation).....	16
8.6	Re-air purging (Re-installation).....	17
8.7	Balance refrigerant of the 2-way, 3-way valves.....	18
8.8	Evacuation.....	19
8.9	Gas charging .....	20
<b>9.</b>	<b>Pressure table .....</b>	<b>21</b>
9.1	MSV1-09HRDN1 .....	21
9.2	MSV1-12HRDN1 .....	21
<b>10.</b>	<b>Capacity table.....</b>	<b>22</b>
10.1	MSV1-09HRDN1 .....	22
10.2	MSV1-12HRDN1 .....	22
<b>11.</b>	<b>Electronic function.....</b>	<b>24</b>
11.1.	Display board.....	24
11.2.	Protection .....	25
11.3.	Fan-only mode.....	25
11.4.	Cooling mode .....	25
11.5.	Dehumidifying mode .....	26
11.6.	Heating mode .....	26
11.7.	Defrosting operation (Available for heating only). .....	27
11.8.	Outdoor low temperature protection (optional) .....	28
11.9.	Automatic operation mode .....	28

11.10.	Manual switch .....	28
11.11.	Timer Function .....	28
11.12.	Sleep mode .....	28
11.13.	Auto restart function.....	29
11.14.	Turbo function.....	29
<b>12.</b>	<b>Model and Parameters.....</b>	<b>30</b>
<b>13.</b>	<b>Troubleshooting.....</b>	<b>31</b>
13.1	Indoor Unit Error Display .....	31
13.2	Diagnostic chart.....	36
13.3	Resetting phenomenon often occurs during operation .....	38
13.4	Operation lamp flashes and Timer lamp off .....	38
13.5	Operation lamp flashes and Timer lamp on .....	38
13.6	Operation lamp off and Timer lamp flashes .....	39
13.7	Operation lamp on and Timer lamp flashes .....	39
13.8	Operation lamp flashes, Timer lamp flashes.....	39
<b>14</b>	<b>Characteristic of temperature sensor .....</b>	<b>40</b>



## 1. Precaution

### 1.1 Safety Precaution

- To prevent injury to the user or other people and property damage, the following instructions must be followed.
- Incorrect operation due to ignoring instruction will cause harm or damage.
- Before service unit, be sure to read this service manual at first.

### 1.2 Warning

#### ➤ Installation

- **Do not use a defective or underrated circuit breaker.**  
Use this appliance on a dedicated circuit.  
There is risk of fire or electric shock.
- **For electrical work, contact the dealer, seller, a qualified electrician, or an Authorized service center.**  
Do not disassemble or repair the product, there is risk of fire or electric shock.
- **Always ground the product.**  
There is risk of fire or electric shock.
- **Install the panel and the cover of control box securely.**  
There is risk of fire of electric shock.
- **Always install a dedicated circuit and breaker.**  
Improper wiring or installation may cause fore or electric shock.
- **Use the correctly rated breaker of fuse.**  
There is risk of fire or electric shock.
- **Do not modify or extend the power cable.**  
There is risk of fire or electric shock.
- **Do not install, remove, or reinstall the unit by yourself (customer).**  
There is risk of fire, electric shock, explosion, or injury.
- **Be caution when unpacking and installing the product.**  
Sharp edges could cause injury, be especially careful of the case edges and the fins on the condenser and evaporator.
- **For installation, always contact the dealer or an Authorized service center.**  
There is risk of fire, electric shock, explosion, or injury.
- **Do not install the product on a defective installation stand.**  
It may cause injury, accident, or damage to the product.
- **Be sure the installation area does not deteriorate with age.**  
If the base collapses, the air conditioner could fall with it, causing property damage, product failure, and personal injury.
- **Do not let the air conditioner run for a long time when the humidity is very high and a door or a windows is left open.**  
Moisture may condense and wet or damage furniture.
- **Take care to ensure that power cable could not be pulled out or damaged during operation.**  
There is risk of fire or electric shock.
- **Do not place anything on the power cable.**  
There is risk of fire or electric shock.
- **Do not plug or unplug the power supply plug during operation.**  
There is risk of fire or electric shock.
- **Do not touch (operation) the product with wet hands.**  
There is risk of fire or electric shock.
- **Do not place a heater or other appliance near the power cable.**  
There is risk of fire and electric shock.
- **Do not allow water to run into electric parts.**  
It may cause fire, failure of the product, or electric shock.
- **Do not store or use flammable gas or combustible near the product.**  
There is risk of fire or failure of product.
- **Do not use the product in a tightly closed space for a long time.**  
Oxygen deficiency could occur.
- **When flammable gas leaks, turn off the gas and open a window for ventilation before turn the product on.**  
Do not use the telephone or turn switches on or off.  
There is risk of explosion or fire.
- **If strange sounds, or small or smoke comes from product. Turn the breaker off or disconnect the power supply cable.**  
There is risk of electric shock or fire.
- **Stop operation and close the window in storm or hurricane. If possible, remove the product from the window before the hurricane arrives.**  
There is risk of property damage, failure of product, or electric shock.
- **Do not open the inlet grill of the product during operation. (Do not touch the electrostatic filter, if the unit is so equipped.)**  
There is risk of physical injury, electric shock, or product failure.
- **When the product is soaked (flooded or submerged), contact an Authorized service center.**  
There is risk of fire or electric shock.
- **Be caution that water could not enter the product.**  
There is risk of fire, electric shock, or product damage.
- **Ventilate the product from time to time when operating it together with a stove, etc.**  
There is risk of fire or electric shock.
- **Turn the main power off when cleaning or maintaining the product.**

There is risk of electric shock.

- **When the product is not be used for a long time, disconnect the power supply plug or turn off the breaker.**

There is risk of product damage or failure, or unintended operation.

- **Take care to ensure that nobody could step on or fall onto the outdoor unit.**

This could result in personal injury and product damage.

### ➤ CAUTION

- **Always check for gas (refrigerant) leakage after installation or repair of product.**

Low refrigerant levels may cause failure of product.

- **Install the drain hose to ensure that water is drained away properly.**

A bad connection may cause water leakage.

- **Keep level even when installing the product.**

To avoid vibration of water leakage.

- **Do not install the product where the noise or hot air from the outdoor unit could damage the neighborhoods.**

It may cause a problem for your neighbors.

- **Use two or more people to lift and transport the product.**

Avoid personal injury.

- **Do not install the product where it will be exposed to sea wind (salt spray) directly.**

It may cause corrosion on the product. Corrosion, particularly on the condenser and evaporator fins, could cause product malfunction or inefficient operation.

### ➤ Operational

- **Do not expose the skin directly to cool air for long periods of time. (Do not sit in the draft).**

This could harm to your health.

- **Do not use the product for special purposes, such as preserving foods, works of art, etc. It is a**

**consumer air conditioner, not a precision refrigerant system.**

There is risk of damage or loss of property.

- **Do not block the inlet or outlet of air flow.**

It may cause product failure.

- **Use a soft cloth to clean. Do not use harsh detergents, solvents, etc.**

There is risk of fire, electric shock, or damage to the plastic parts of the product.

- **Do not touch the metal parts of the product when removing the air filter. They are very sharp.**

There is risk of personal injury.

- **Do not step on or put anything on the product. (outdoor units)**

There is risk of personal injury and failure of product.

- **Always insert the filter securely. Clean the filter every two weeks or more often if necessary.**

A dirty filter reduces the efficiency of the air conditioner and could cause product malfunction or damage.

- **Do not insert hands or other object through air inlet or outlet while the product is operated.**

There are sharp and moving parts that could cause personal injury.

- **Do not drink the water drained from the product.**

It is not sanitary could cause serious health issues.

- **Use a firm stool or ladder when cleaning or maintaining the product.**

Be careful and avoid personal injury.

- **Replace the all batteries in the remote control with new ones of the same type. Do not mix old and new batteries or different types of batteries.**

There is risk of fire or explosion.

- **Do not recharge or disassemble the batteries. Do not dispose of batteries in a fire.**

They may burn or explode.

- **If the liquid from the batteries gets onto your skin or clothes, wash it well with clean water. Do not use the remote of the batteries have leaked.**

The chemical in batteries could cause burns or other health hazards.

## 2. Function

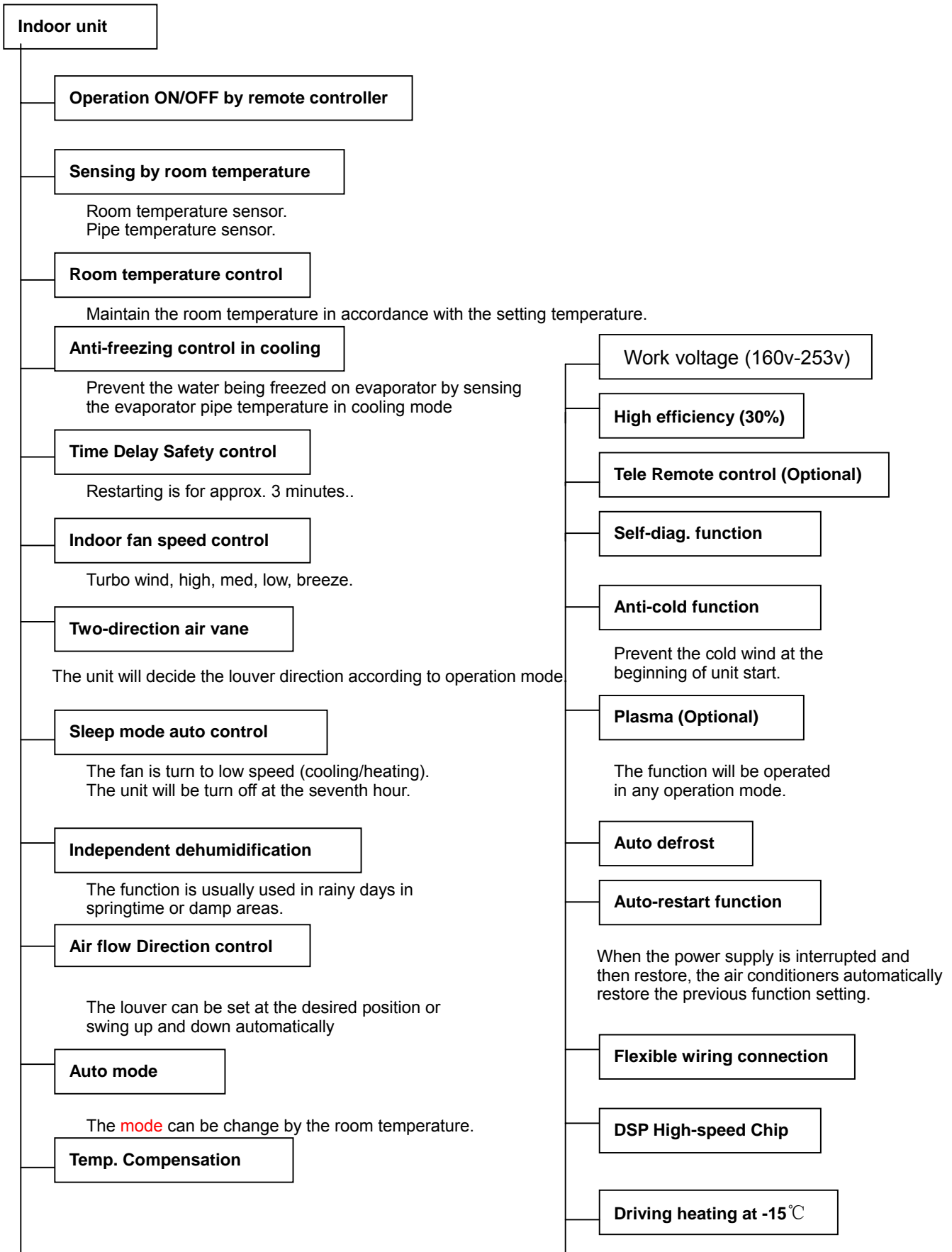

**Outdoor unit**

**Power relay control**

The unit has 3 mins delay between continuously ON/OFF operations.

**Low noise air flow system**

Bird tail propeller fan makes the outdoor unit run more quietly.

**Hydrophilic aluminum fin**

The hydrophilic fin can improve the heating efficiency at operation mode.

**4 way valve control**

It is only operated in the heating operation mode except defrosting operation.

**Anti-rust cabinet**

Made from electrolytic zinc steel sheet and anti-rust coated components.

**Valve protection cover**

It protects the valves and prevents water from dripping.

**Discharge pipe temperature protect**



**3. Dimension**  
**3.1 Indoor unit (Vertu)**

Dimension Mode	W	H	D
9K	795	270	165
12K	845	286	165

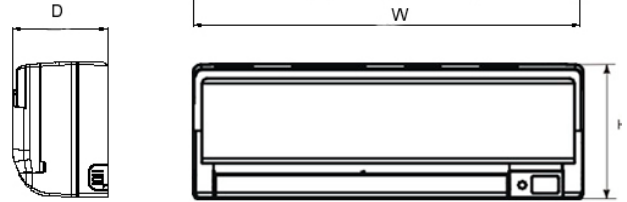

**3.2 Outdoor unit (Vertu)**

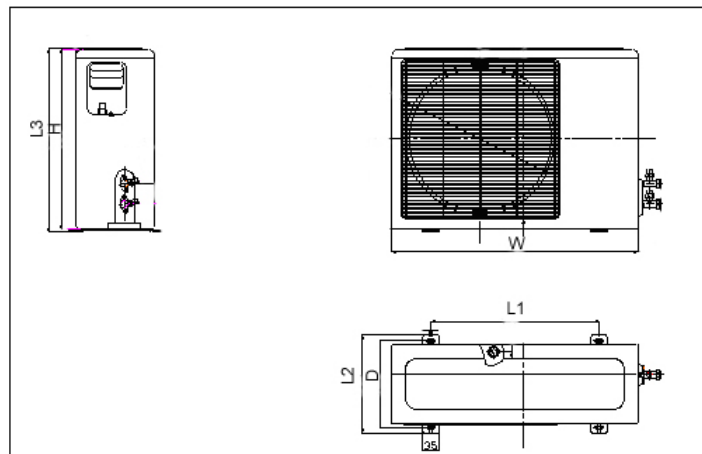

Dimension Mode	W	H	D
9K	760	590	285
12K	760	590	285

#### 4. Specification

Model			MSV1-09HRDN1	MSV1-12HRDN1
Power supply		Ph-V-Hz	1,220-240V~,50Hz	1, 220-240V~, 50Hz
Cooling	Capacity	Btu/h	9000(3500-11000)	12000(4400-14500)
	Input	W	810(260-1350)	1090(520-1600)
	Rated current	A	3.3(1.5-7.0)	5.1(2.7~8.5)
	EER	Btu/w.h, w/w	11.1,3.26	11.0, 3.21
Heating	Capacity	Btu/h	10000(3500-13800)	14000(4800-20500)
	Input	W	810(330-1550)	1130(520-2050)
	Rated current	A	3.5(1.4-7.5)	5.2(2.7-10.0)
	COP	W/W	3.62	3.63
Moisture Removal		L/h	0.86	1.2
Max. input consumption		W	1900	2550
Max. current		A	10	12
Starting current		A	3.3	4.1
Compressor	Model		DA89X1C-23FZ	DA89X1C-23FZ
	Type		Rotary	Rotary
	Brand		TOSHIBA	TOSHIBA
	Capacity	Btu/h	9040	9040
	Input	W	680	680
	Rated current(RLA)	A	4.7	4.7
	Locked rotor Amp(LRA)	A	10	10
	Thermal protector		CS-74	CS-74
	Capacitor	uF	No	No
	Refrigerant oil	ml	370	370
Indoor fan motor	Model		RPG20D	RPG20D
	Brand		Welling	Welling
	Input	W	51.5	51.5
	Capacitor	uF	1.5	1.5
	Speed(hi/mi/lo)	r/min	1150/1000/850	1250/1050/900
Indoor air flow (Hi/Mi/Lo)		m <sup>3</sup> /h	570/480/350	700/520/420
Indoor noise level (Hi/Mi/Lo)		dB(A)	40/34/29	42/35/29
Outdoor fan motor	Model		YDK24-6F	YDK24-6F
	Brand		Welling	Welling
	Input	W	56	56
	Capacitor	uF	2.5	2.5
	Speed	r/min	800	800
Outdoor air flow		m <sup>3</sup> /h	1700	1900
Outdoor noise level		dB(A)	53	56
Refrigerant type R410A		g	980	1150
Design pressure		MPa	4.2	4.2
Refrigerant piping	Liquid side/ Gas side	mm(inch)	Φ6.35/Φ9.53	Φ6.35/Φ12.7
	Max. refrigerant pipe leng	m	12	12
	Max. difference in level	m	5	5
Operation temp		℃	17 - 30	17 -30
Ambient temp		℃	-15 -50	-15 -50
Application area		m <sup>2</sup>	14-21	18-26

Note:

The noise date is base on hemi-anechoic chamber, during actual operation; these values are normally somewhat different as a result of ambient condition.

The above design and specifications are subject to change without prior notice for product improvement.

### 5. Refrigerant cycle diagram

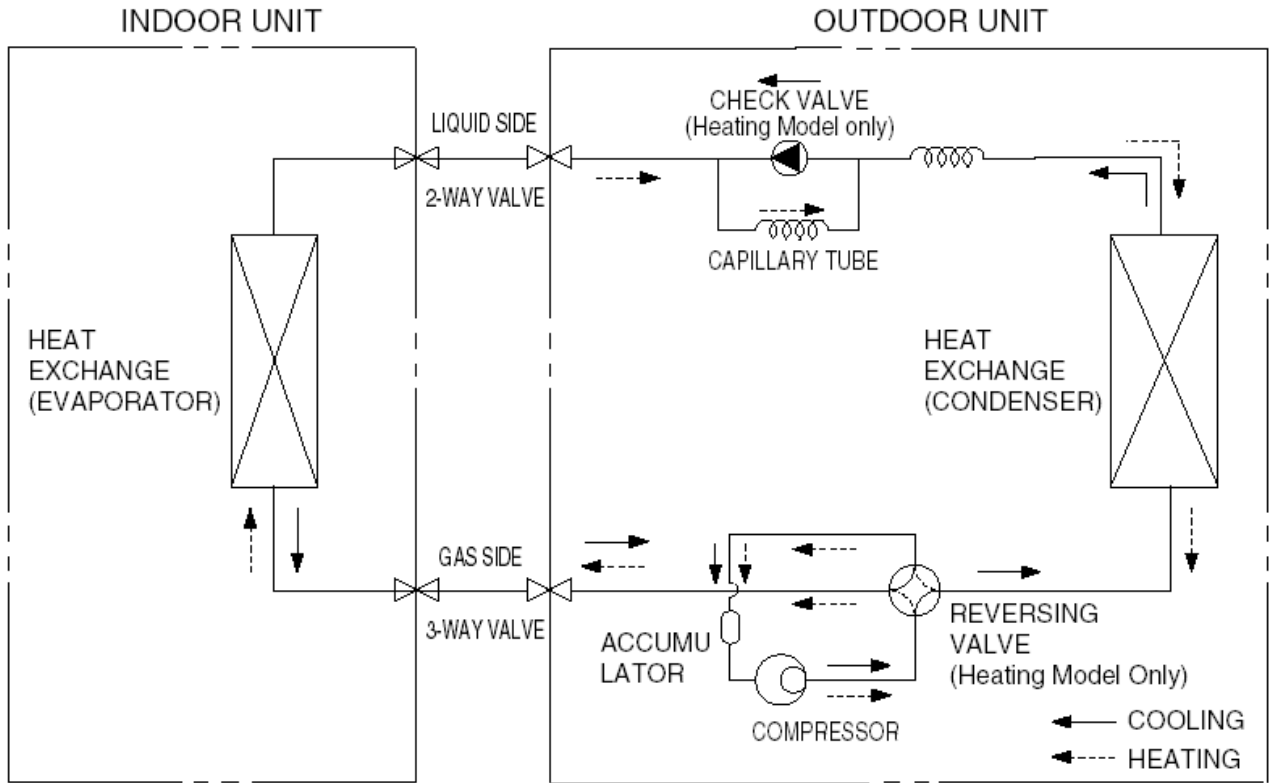

**6. Operation limits**  
**6.1 Cooling operation**

Outdoor unit air temp. °C DB

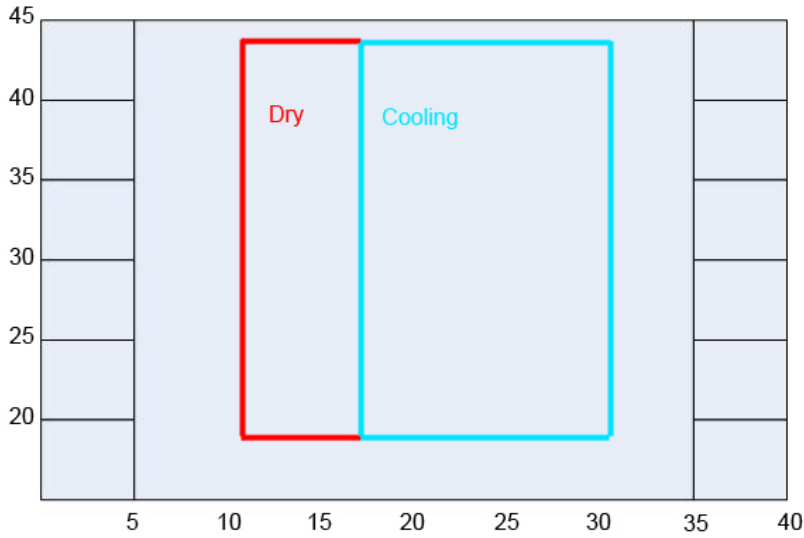

Indoor air temp. °C DB

Note: The chart is the result from the continuous operation under constant air temperature conditions. However, excludes the initial pull-down stage.

**6.2 Heating operation**

Indoor air temp. °C DB

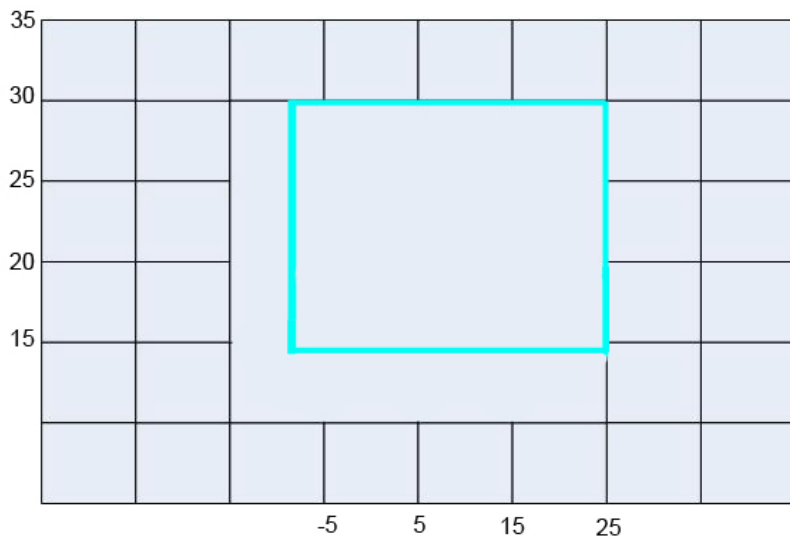

Outdoor unit air temp. °C DB

Note: The chart is the result from the continuous operation under constant air temperature conditions. However, excludes the initial pull-down stage.

## 7. Schematic diagram and Wiring diagram

### 7.1. Schematic diagram

#### 7.1.1 Display board

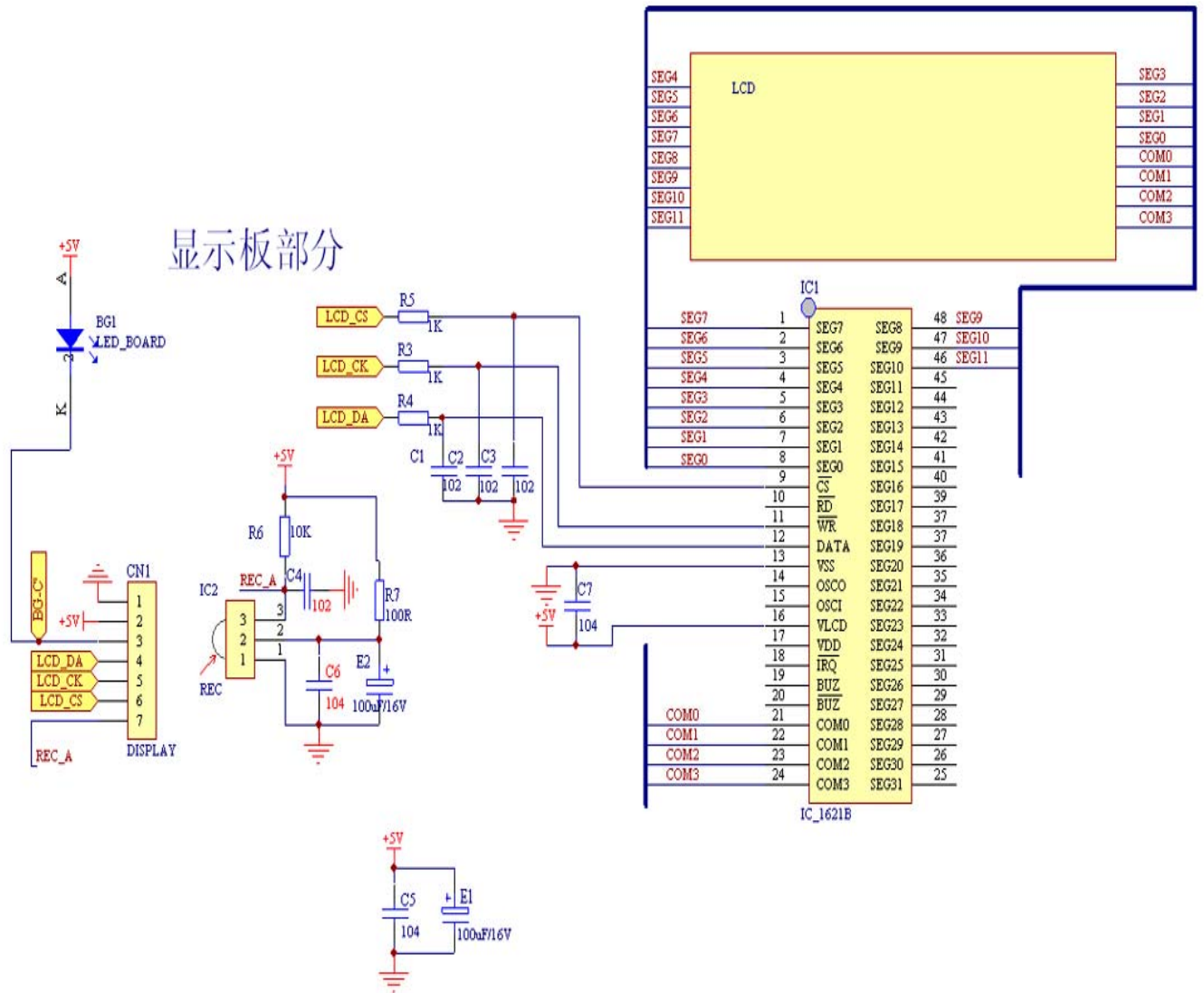

7.1.2 Indoor main PCB

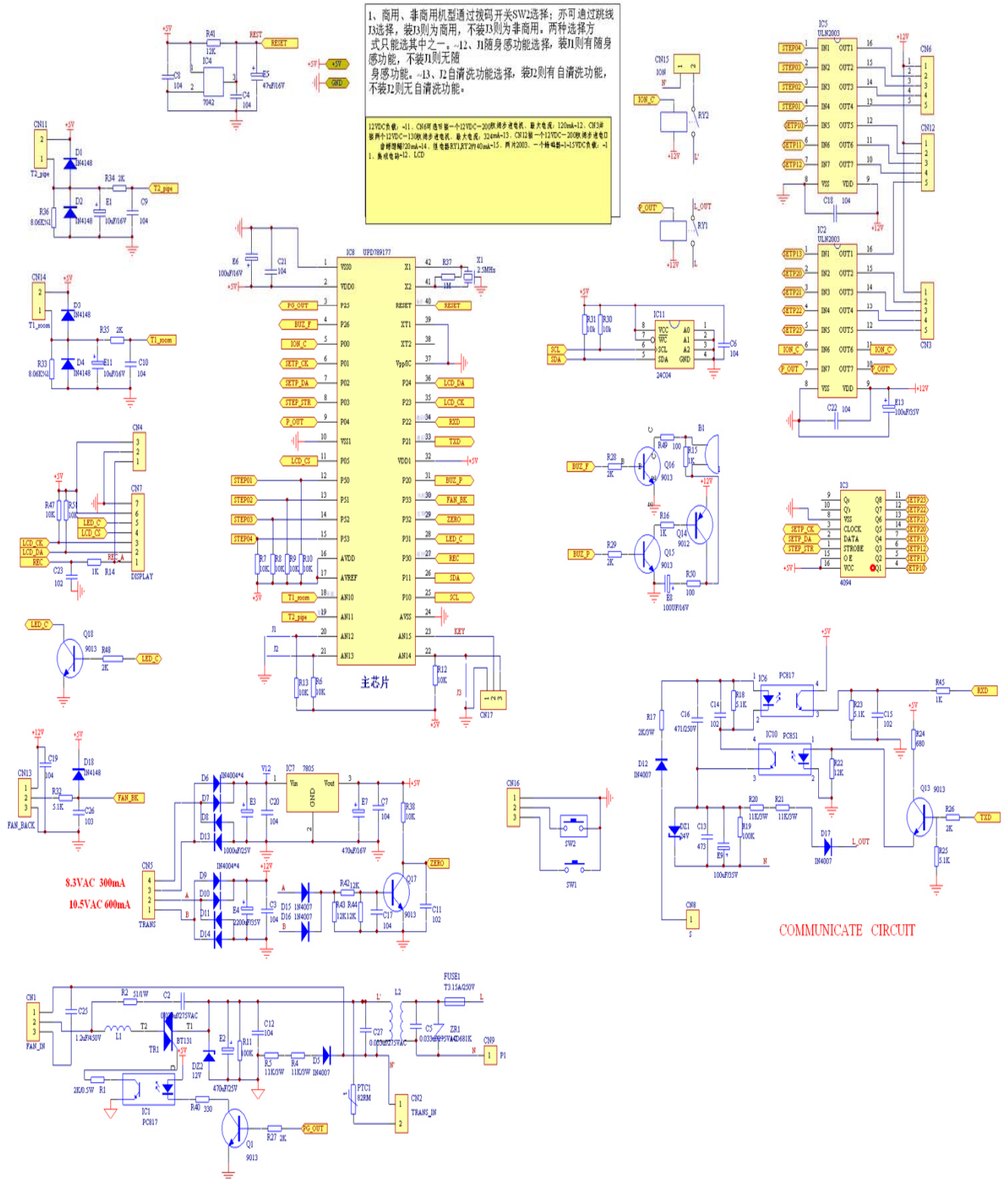

7.1.3 Outdoor main PCB

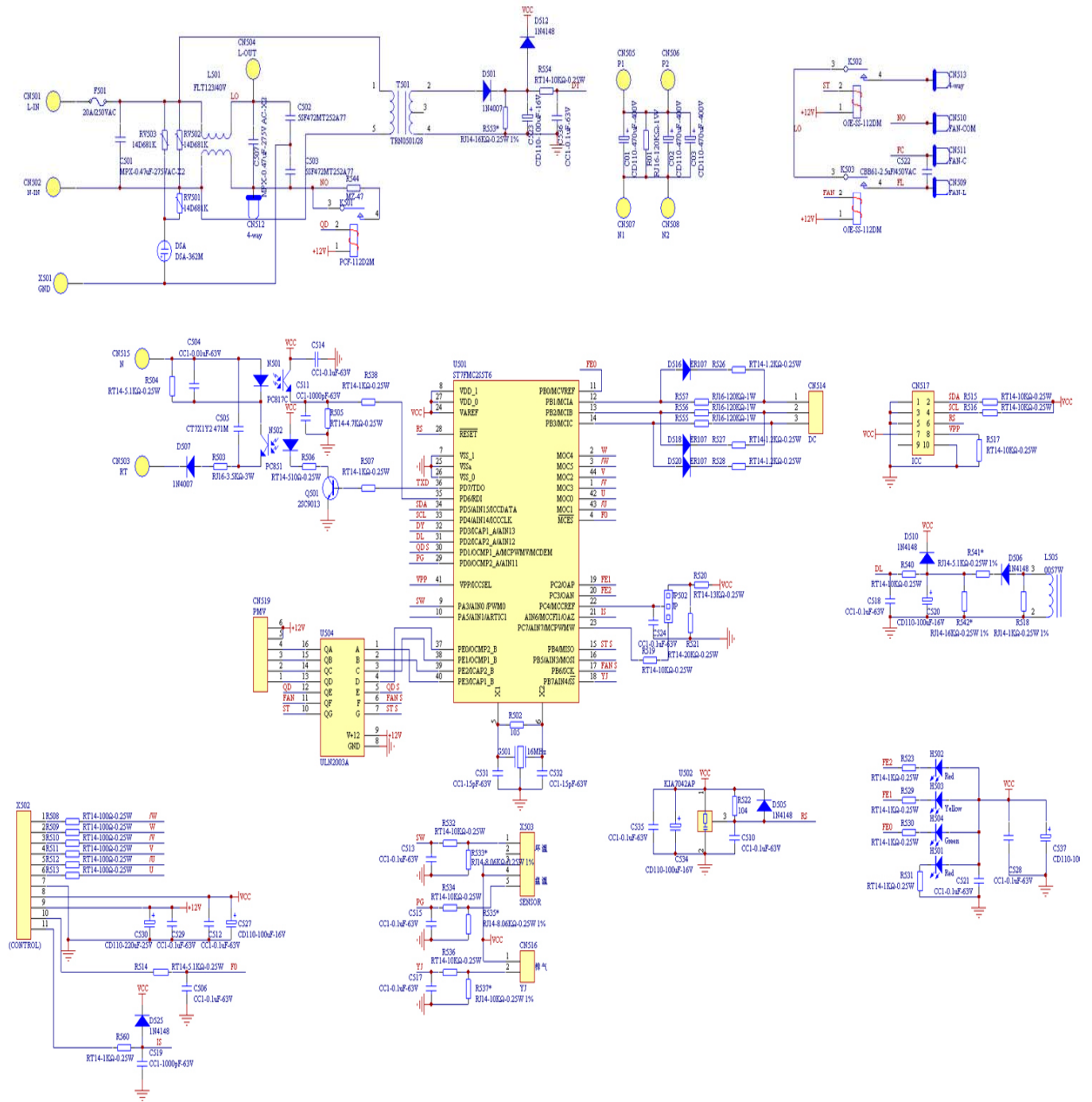

7.1.4 Outdoor power PCB

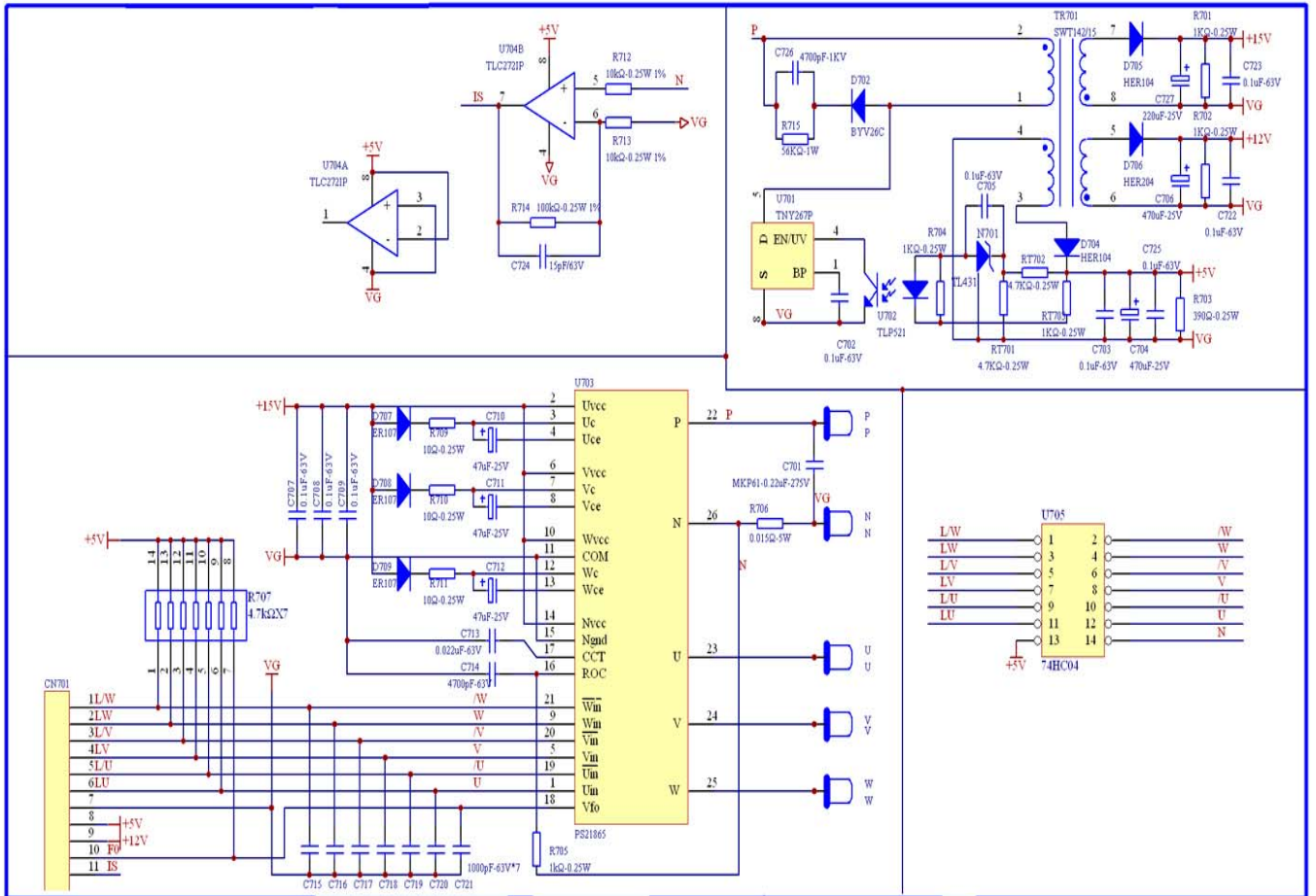





## 8. Installation details

### 8.1 Wrench torque sheet for installation

Outside diameter		Torque
mm	inch	
φ 6.35	1/4	1.8
φ 9.52	3/8	4.2
φ 12.7	1/2	5.5
φ 15.88	5/8	6.6
φ 19.05	3/4	6.6

### 8.2 Connecting the cables

The power cord of connect should be selected according to the following specifications sheet.

	Grade		
Unit	7K	9K	12K
mm <sup>2</sup>	1.0	1.0	1.5

### 8.3 Pipe length and the elevation

Capacity Btu/h	Pipe size		Standard length (m)	Max. Elevation B (m)	Max. Elevation B (m)	Additional refrigerant (g/m)
	GAS	LIQUID				
7k~12K	3/8" ( φ 9.52)	1/4" ( φ 6.35)	5	5	10	30
	1/2" ( φ 12.7)	1/4" ( φ 6.35)	5	5	10	30
18K~28K	1/2" ( φ 12.7)	1/4" ( φ 6.35)	5	8	15	30
	5/8" ( φ 15.88)	1/4" ( φ 6.35)	5	10	20	30
	5/8" ( φ 15.88)	3/8" ( φ 9.52)	5	10	20	65

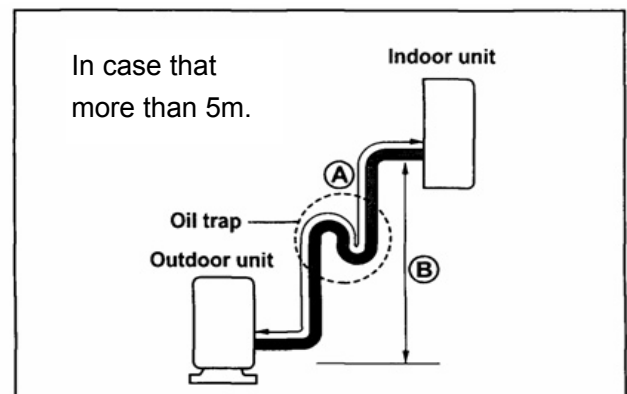
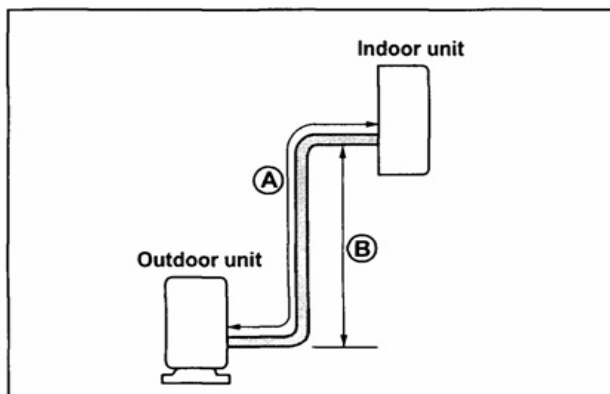

Caution:

Capacity is base on standard length and maximum allowance length is base of reliability.

Oil trap should be install per 5-7 meters.

## 8.4 Air purging of the piping and indoor unit

Required tools:

Hexagonal wrench; adjustable wrench; torque wrenches, wrench to hold the joints and gas leak detector.

Note:

The air in the indoor unit and in the piping must be purged. If air remains in the refrigeration piping, it will affect the compressor, reduce the cooling capacity, and could lead to a malfunction of unit.

Be sure, using a torque wrench to tighten the service port cap (after using the service port), so that it prevents the gas leakage from the refrigeration cycle.

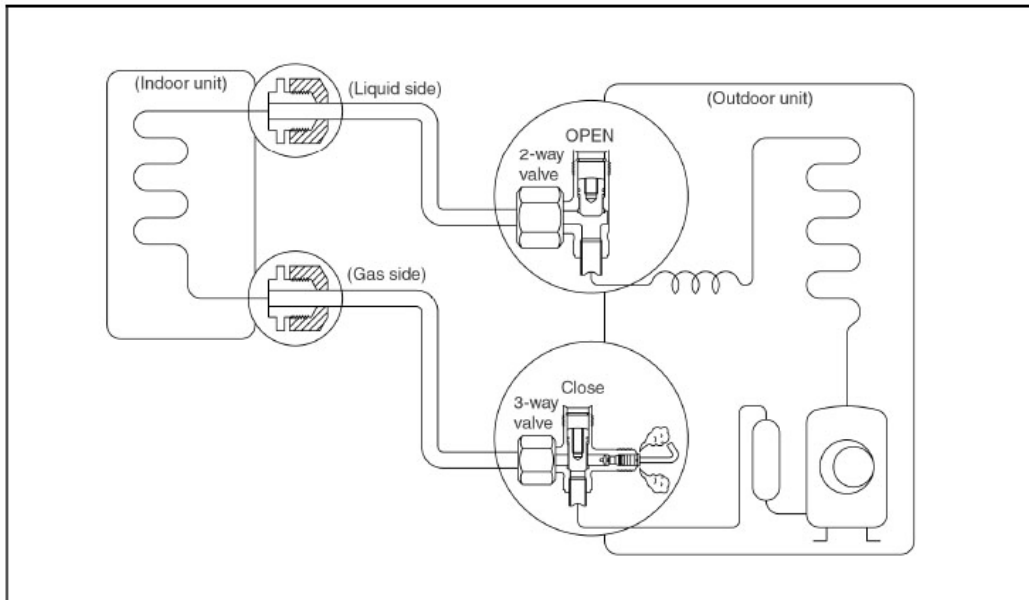

Procedure

**1. Recheck the piping connections.**

**2. Open the valve stem of the 2-way valve counterclockwise approximately 90°, wait 10 seconds, and then set it to closed position.**

- Be sure to use a hexagonal wrench to operate the valve stem

**3. Check for gas leakage.**

- Check the flare connection for gas leakage

**4. Purge the air from the system.**

- Set the 2-way valve to the open position and remove the cap from the 3-way valve's service port.
- Using the hexagonal wrench to press the valve core pin, discharge for three seconds and then wait for one minute.

**5. Use torque wrench to tighten the service port cap to a torque of 1.8 kg.m. (18n.m)**

**6. Set the 3-way valve to the opened position.**

**7. Mounted the valve stem nuts to the 2-way and 3-way valves.**

**8. Check for gas leakage.**

- At this time, especially check for gas leakage from the 2-way and 3-way stem nuts, and from the service port.

Caution:

If gas leakage is discovered in step (3) above, take the following measures.

If the leaks stop when the piping connections are tightened further, continue working from step (4). If the gas leaks do not stop when the connections are retightened, repair the location of the leak, discharge all of the gas through the service port, and then recharge with the specified amount of gas from a gas cylinder.

## 8.5 Pumping down (Re-installation)

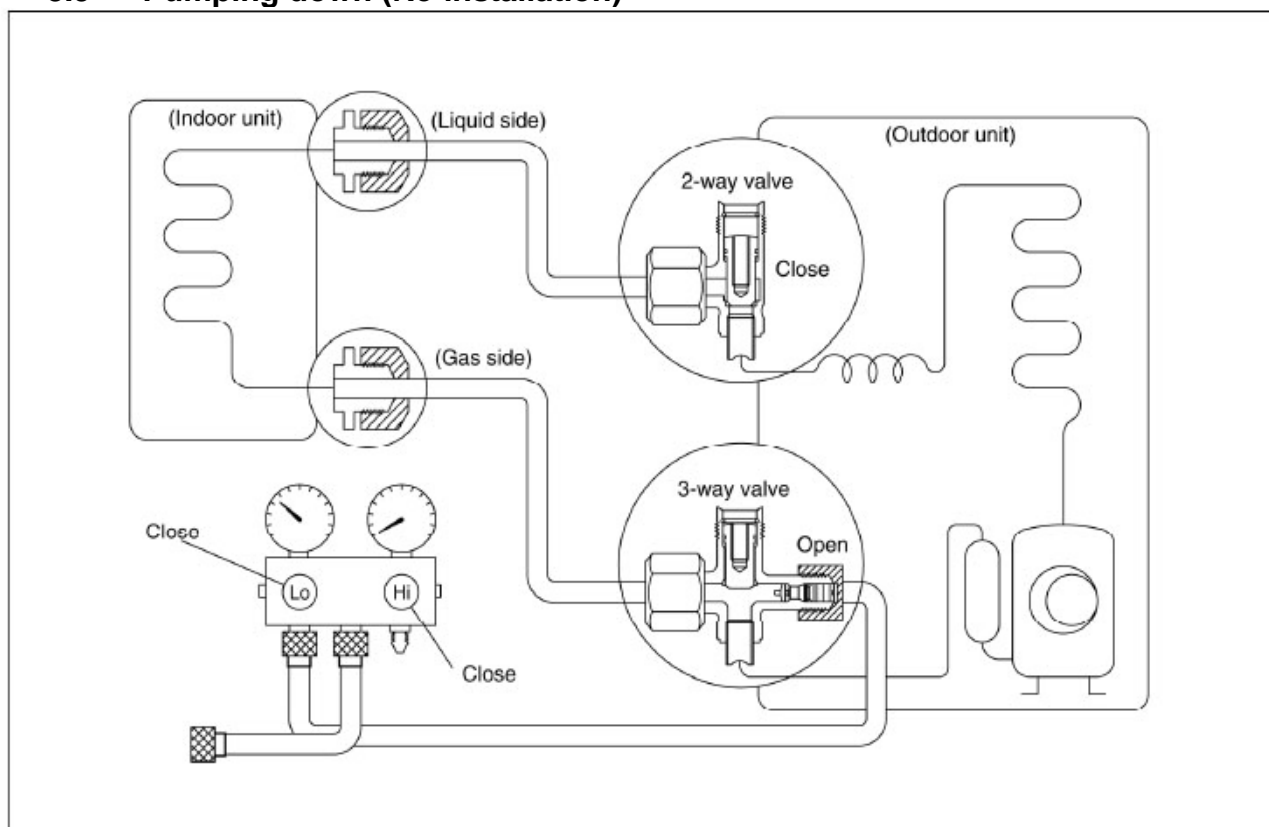

### Procedure

- 1. Confirm that both the 2-way and 3-way valves are set to the opened position.**
  - Remove the valve stem caps and confirm that the valve stems are in the opened position.
  - Be sure to use a hexagonal wrench to operate the valve stems.
- 2. Operate the unit for 10 to 15 minutes.**
- 3. Stop operation and wait for 3 minutes, then connect the charge set to the service port of the 3-way valve.**
  - Connect the charge hose with the push pin to the gas service port.
- 4. Air purging of the charge hose.**
  - Open the low-pressure valve on the charge set slightly to purge air from the charge hose.
- 5. Set the 2-way valve to the closed position.**
- 6. Operate the air conditioner at the cooling cycle and stop it when the gauge indicates 0.1MPa.**
- 7. Immediately set the 3-way valve to the closed position.**
  - Do this quickly so that the gauge ends up indicating 0.3 to 0.5Mpa.
- 8. Disconnect the charge set, and amount the 2-way and 3-way valve's stem nuts and service port caps.**
  - Use a torque wrench to tighten the service port cap to a torque of 1.8 kg.m.
  - Be sure to check for gas leakage.

## 8.6 Re-air purging (Re-installation)

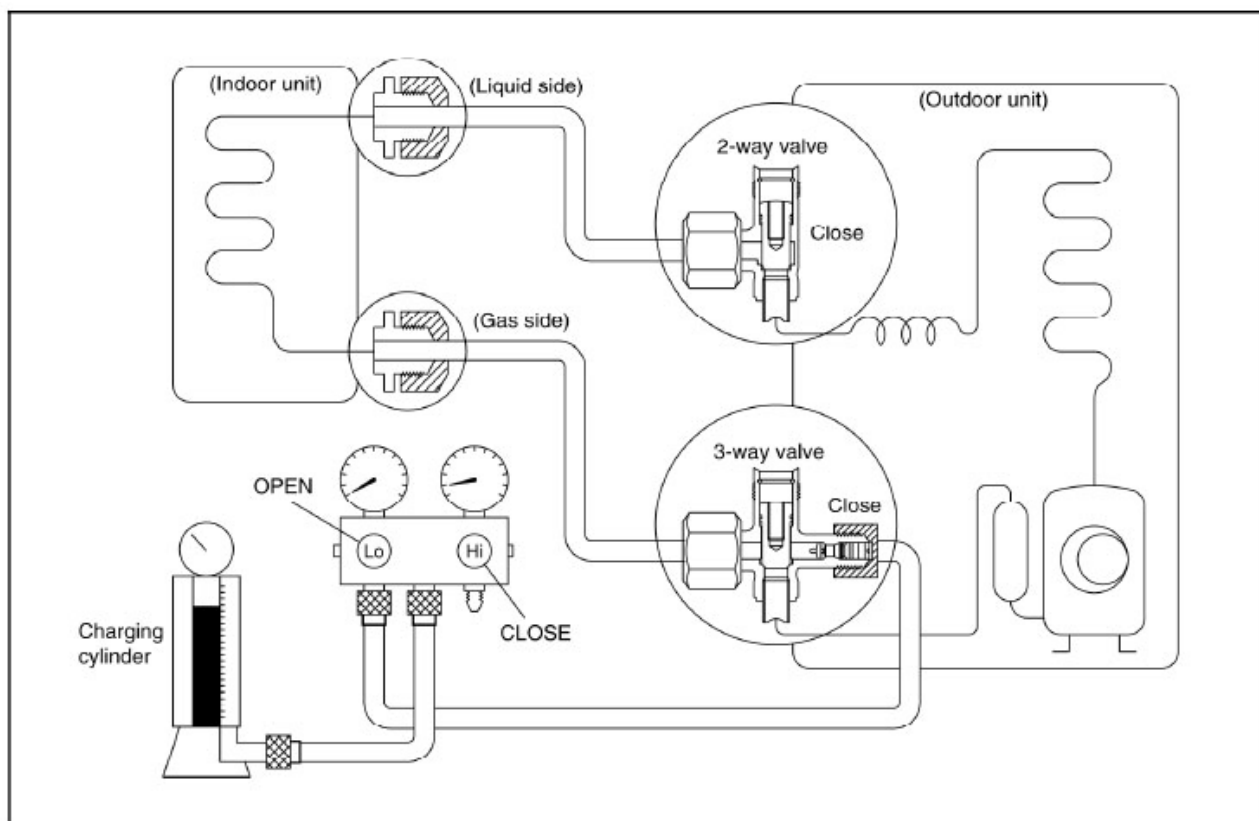

### Procedure:

1. **Confirm that both the 2-way and 3-way valves are set to the closed position.**
2. **Connect the charge set and a charging cylinder to the service port of the 3-way valve.**
  - Leave the valve on the charging cylinder closed.
3. **Air purging.**
  - Open the valves on the charging cylinder and the charge set. Purge the air by loosening the flare nut on the 2-way valve approximately 45° for 3 seconds then closing it for 1 minutes; repeat 3 times.
  - After purging the air, use a torque wrench to tighten the flare nut to on the 2-way valve.
4. **Check the gas leakage.**
  - Check the flare connections for gas leakage.
5. **Discharge the refrigerant.**
  - Close the valve on the charging cylinder and discharge the refrigerant until the gauge indicate 0.3 to 0.5 Mpa.
6. **Disconnect the charge set and the charging cylinder, and set the 2-way and 3-way valves to the open position.**
  - Be sure to use a hexagonal wrench to operate the valve stems.
7. **Mount the valve stems nuts and the service port cap.**
  - Be sure to use a torque wrench to tighten the service port cap to a torque 18N.m.
  - Be sure to check the gas leakage.

## 8.7 Balance refrigerant of the 2-way, 3-way valves

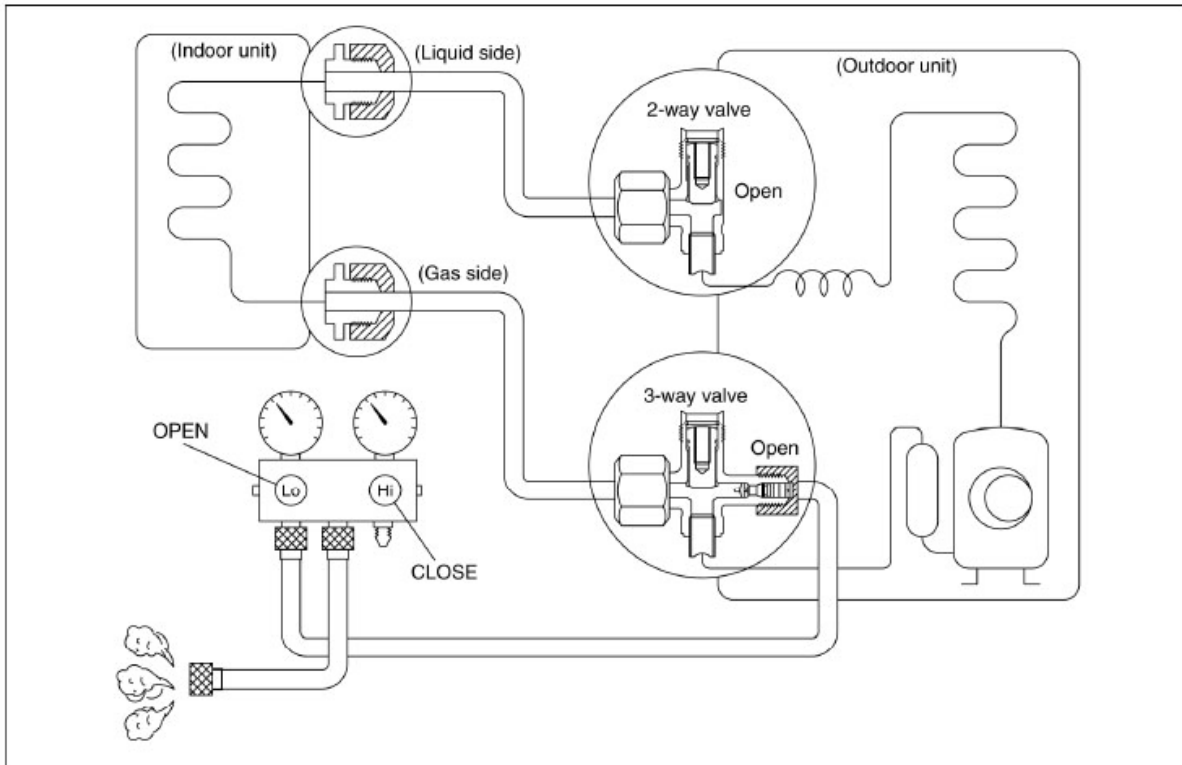

Procedure:

1. Confirm that both the 2-way and 3-way valves are set to the open position.
2. Connect the charge set to the 3-way valve's service port.
  - Leave the valve on the charge set closed.
  - Connect the charge hose with the push pin to the service port.
3. Open the valves (Low side) on the charge set and discharge the refrigerant until the gauge indicates 0.05 to 0.1 Mpa.
  - If there is no air in the refrigeration cycle [the pressure when the air conditioner is not running is higher than 0.1Mpa, discharge the refrigerant until the gauge indicates 0.05 to 0.1 Mpa. If this is the case, it will not be necessary to apply a evacuation.
  - Discharge the refrigeration gradually; if it is discharged too suddenly, the refrigeration oil will be discharged.

## 8.8 Evacuation

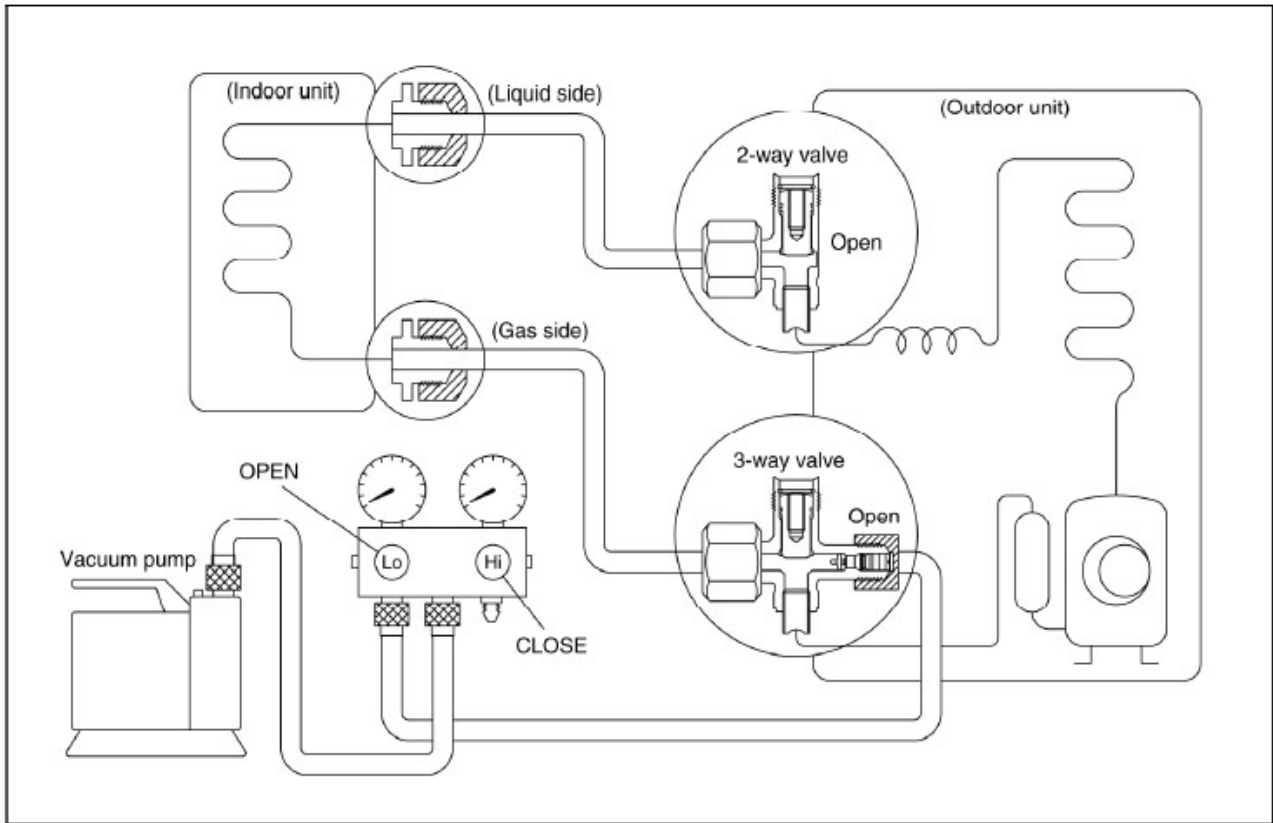

Procedure:

1. Connect the vacuum pump to the charge set's centre hose.
2. Evacuation for approximately one hour.
  - Confirm that the gauge needle has moved toward -0.1 Mpa (-76 cmHg) [vacuum of 4 mmHg or less].
3. Close the valve (Low side) on the charge set, turn off the vacuum pump, and confirm that the gauge needle does not move (approximately 5 minutes after turning off the vacuum pump).
4. Disconnect the charge hose from the vacuum pump.
  - Vacuum pump oil, if the vacuum pump oil becomes dirty or depleted, replenish as needed.

## 8.9 Gas charging

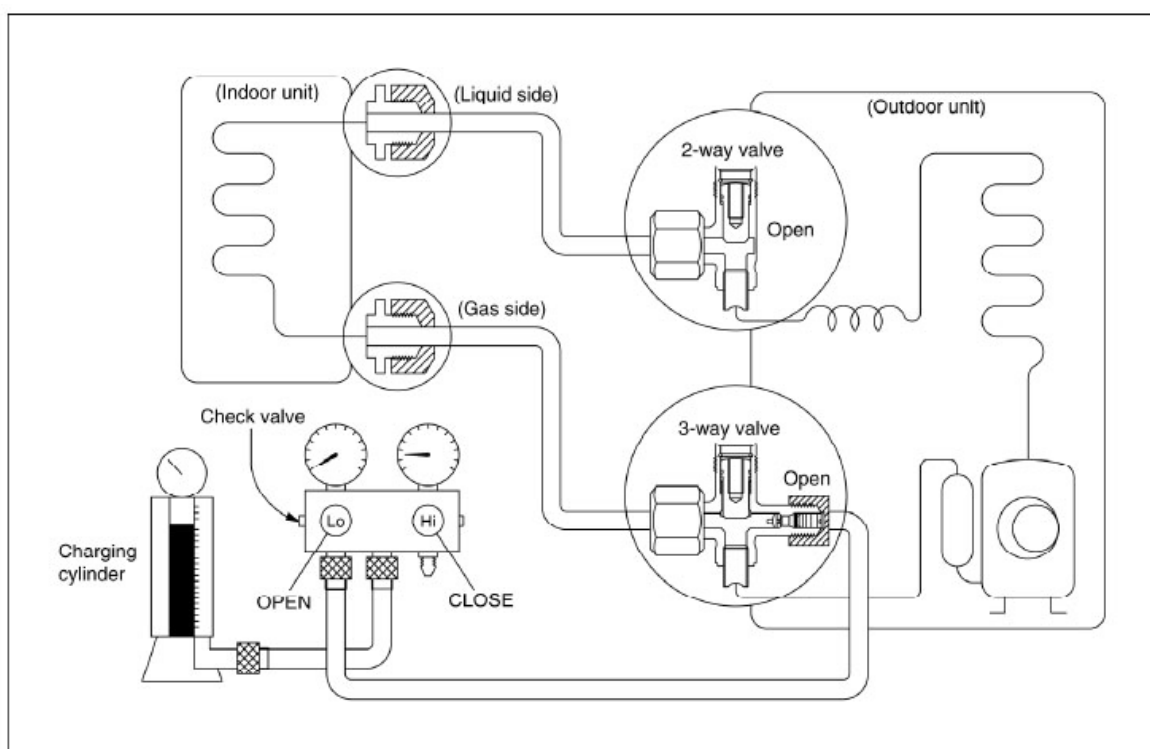

Procedure:

**1. Connect the charge hose to the charging cylinder.**

- Connect the charge hose which you disconnected from the vacuum pump to the valve at the bottom of the cylinder.

**2. Purge the air from the charge hose.**

- Open the valve at the bottom of the cylinder and press the check valve on the charge set to purge the air (be careful of the liquid refrigerant).

**3. Open the valves (Low side) on the charge set and charge the system with liquid refrigerant.**

- If the system cannot be charge with the specified amount of refrigerant, it can be charged with a little at a time (approximately 150g each time) while operating the air conditioner in the cooling cycle; however, one time is not sufficient, wait approximately 1 minute and then repeat the procedure.(pumping down-pin).

**4. Immediately disconnect the charge hose from the 3-way valve's service port.**

- Stopping partway will allow the refrigerant to be discharged.
- If the system has been charged with liquid refrigerant while operating the air conditioner, turn off the air conditioner before disconnecting the hose.

**5. Mounted the valve stem caps and the service port**

- Use torque wrench to tighten the service port cap to a torque of 18N.m.
- Be sure to check for gas leakage.



## 9. Pressure table

Note:

The pressure data is from 3 way valve, the pressure data are pressure above atmosphere.

D: Dry bulb temp.

W: Wet bulb temp.

### 9.1 MSV1-09HRDN1

Cooling mode		Outdoor temperature (Dry bulb temp)					
Indoor Conditions	Pressure	25°C	30°C	35°C	40°C	45°C	50°C
21°C D15°C W	Pressure( kg/cm <sup>2</sup> )	8.7	8.9	8.9	9.0	10.0	10.6
24°C D17°C W	Pressure( kg/cm <sup>2</sup> )	8.8	8.9	8.9	9.6	10.5	11.0
27°C D19°C W	Pressure( kg/cm <sup>2</sup> )	8.8	8.9	9.0	9.0	11.0	11.5
32°C D23°C W	Pressure( kg/cm <sup>2</sup> )	8.9	9.0	9.1	10.1	12.0	12.5

Heating mode		OUTDOOR CONDITIONS					
Indoor Conditions	Pressure	12°C D	7°C D	0°C D	-4°C D	-7°C D	-15°C D
		11°C W	6°C W	-1°C W	-6°C W	-9°C W	-x°C W
15°C	Pressure( kg/cm <sup>2</sup> )	34.0	33.5	32.0	31.0	28.0	27.0
18°C	Pressure( kg/cm <sup>2</sup> )	35.0	34.5	34.0	32.5	29.0	27.5
20°C	Pressure( kg/cm <sup>2</sup> )	36.5	36.0	35.5	33.5	30.0	28.5
22°C	Pressure( kg/cm <sup>2</sup> )	37.0	36.5	36.0	35.0	31.5	29.0

### 9.2 MSV1-12HRDN1

Cooling mode		Outdoor temperature (Dry bulb temp)					
Indoor Conditions	Pressure	25°C	30°C	35°C	40°C	45°C	50°C
21°C D15°C W	Pressure( kg/cm <sup>2</sup> )	6.4	6.6	6.8	7.2	7.6	8.1
24°C D17°C W	Pressure( kg/cm <sup>2</sup> )	6.6	6.9	7.0	7.6	8.2	8.7
27°C D19°C W	Pressure( kg/cm <sup>2</sup> )	6.9	7.0	7.3	7.6	8.6	9.2
32°C D23°C W	Pressure( kg/cm <sup>2</sup> )	6.9	7.4	7.6	8.1	9.4	9.8

Heating mode		OUTDOOR CONDITIONS					
Indoor Conditions	Pressure	12°C D	7°C D	0°C D	-4°C D	-7°C D	-15°C D
		15°C	Pressure( kg/cm <sup>2</sup> )	36.0	35.0	34.5	30.0
18°C	Pressure( kg/cm <sup>2</sup> )	33.0	34.0	33.5	30.0	28.5	27.5
20°C	Pressure( kg/cm <sup>2</sup> )	34.0	33.0	31.0	30.5	29.0	26.0
22°C	Pressure( kg/cm <sup>2</sup> )	32.5	31.5	31.0	29.0	28.0	25.5

## 10. Capacity table

### 10.1 MSV1-09HRDN1

COOLING		OUTDOOR TEMPERATURE DRY						
Indoor Conditions		21°C	25°C	30°C	35°C	40°C	45°C	50°C
21°C D 15°C W	Total capacity kW	2.87	3.00	2.60	2.34	1.98	1.70	1.53
	Sensitive capacity kW	1.84	1.91	2.03	1.99	1.65	1.46	1.32
	Input kW.	0.701	0.72	0.80	0.86	0.89	0.98	1.16
24°C D 17°C W	Total capacity kW	2.98	3.15	2.85	2.45	2.30	1.95	1.74
	Sensitive capacity kW	1.84	2.01	2.23	2.11	1.93	1.72	1.50
	Input kW.	0.72	0.73	0.82	0.90	0.92	1.01	1.17
27°C D 19°C W	Total capacity kW	3.13	3.20	2.98	2.58	2.60	2.34	2.03
	Sensitive capacity kW	2.04	2.15	2.30	1.96	2.23	2.09	1.73
	Input kW.	0.75	0.78	0.85	0.76	0.96	1.04	1.19
32°C D 23°C W	Total capacity kW	3.29	3.33	3.12	3.05	2.80	2.62	2.32
	Sensitive capacity kW	2.17	2.15	2.43	2.56	2.38	2.33	2.05
	Input kW.	0.78	0.80	0.86	1.00	1.01	1.08	1.23

HEATING			OUTDOOR CONDITIONS						
Indoor Conditions		24°C D 18°C W	12°C D 11°C W	7°C D 6°C W	4°C D 3°C W	0°C D -1°C W	-5°C D -6°C W	-7°C D -8°C W	-15°C D -16°C W
15°C	Capacity kW	3.5	4.11	4.10	3.80	3.49	3.12	3.01	1.72
	Input kW.	0.958	1.53	1.57	1.56	1.51	1.39	1.37	1.30
18°C	Capacity kW	3.45	4.10	4.05	3.70	3.48	3.11	2.99	1.70
	Input kW.	0.96	1.55	1.58	1.60	1.52	1.40	1.38	1.32
20°C	Capacity kW	3.44	4.05	2.87	3.69	3.47	3.00	2.86	1.69
	Input kW.	0.965	1.60	0.79	1.63	1.54	1.42	1.40	1.35
22°C	Capacity kW	3.435	4.00	3.932	3.65	3.47	2.97	2.81	1.68
	Input kW.	0.98	1.65	1.64	1.67	1.58	1.45	1.43	1.38
27°C	Capacity kW	3.4	3.95	3.85	3.60	3.43	2.89	2.79	1.67
	Input kW.	0.99	1.69	1.69	1.70	1.61	1.50	1.48	1.40

### 10.2 MSV1-12HRDN1

COOLING		OUTDOOR TEMPERATURE DRY						
Indoor Conditions		21°C	25°C	30°C	35°C	40°C	45°C	50°C
21°C D 15°C W	Total capacity kW	3.187	3.48	3.30	3.01	2.81	2.38	2.16
	Sensitive capacity kW	2.23	2.40	2.38	2.28	2.25	2.10	1.90
	Input kW.	0.924	1.08	1.18	1.30	1.39	1.45	1.59
24°C D 17°C W	Total capacity kW	3.579	3.76	3.65	3.43	2.98	2.70	2.44
	Sensitive capacity kW	2.505	2.61	2.66	2.61	2.41	2.35	2.20
	Input kW.	0.957	1.10	1.19	1.33	1.41	1.49	1.61
27°C D 19°C W	Total capacity kW	3.879	4.09	3.90	3.50	3.19	2.99	2.79
	Sensitive capacity kW	2.792	2.86	2.89	2.80	2.58	2.60	2.45
	Input kW.	0.979	1.11	1.20	1.07	1.45	1.51	1.60
32°C D 23°C W	Total capacity kW	4.087	4.32	4.02	3.80	3.62	3.40	3.28
	Sensitive capacity kW	3.168	3.80	3.01	3.07	3.11	2.96	2.89
	Input kW.	0.989	1.12	1.25	1.40	1.48	1.55	1.68

Service manual

HEATING			OUTDOOR CONDITIONS						
Indoor Conditions		24°C D	12°C D	7°C D	4°C D	0°C D	-5°C D	-7°C D	-15°C D
		18°C W	11°C W	6°C W	3°C W	-1°C W	-6°C W	-8°C W	-16°C W
15°C	Capacity kW	4.875	6.15	5.72	5.13	4.52	4.21	3.75	3.41
	Input kW.	1.568	2.07	2.20	2.09	2.01	1.99	1.80	1.76
18°C	Capacity kW	4.801	6.09	5.58	5.02	4.39	4.10	3.59	3.27
	Input kW.	1.6	2.18	2.39	2.20	2.16	2.09	1.83	1.81
20°C	Capacity kW	4.684	5.89	4.03	4.90	4.21	3.89	3.37	3.11
	Input kW.	1.658	2.21	1.11	2.35	2.27	2.15	1.99	1.92
22°C	Capacity kW	4.521	5.58	5.39	4.71	4.10	3.70	3.17	2.99
	Input kW.	1.729	2.28	2.45	2.41	2.40	2.25	2.11	2.00
27°C	Capacity kW	4.387	5.37	4.99	4.48	3.90	3.49	3.01	2.71
	Input kW.	1.804	2.39	2.61	2.55	2.51	2.38	2.27	2.13

## 11. Electronic function

### 11.1. Display board



#### 11.1.1. OPERATION indicator

This indicator flashes after power is on and illuminates when the unit is in operation.

#### 11.1.2. AUTO indicator

This indicator illuminates when the air conditioner is in AUTO operation.

#### 11.1.3. TIMER indicator

This indicator illuminates when TIMER is set ON/OFF.

#### 11.1.4. CLEAN AIR indication lamp

Lights up when CLEAN AIR feature is activated and Ionizer can generate abundant anions to fill the room with refreshing and natural air.

#### 11.1.5. PRE.-DEF. Indicator (For Cooling & Heating models only)

This indicator illuminates when the air conditioner starts defrosting automatically or when the warm air control feature is activated in heating mode.

#### 11.1.6. TURBO indication lamp

Lights up when select TURBO function on cooling operation or on heating operation.

#### 11.1.7. FREQUENCY indicator

This indicator appears only when the compressor is in operation and indicates the current operating frequency.

#### 11.1.8. TEMPERATURE indicator

Usually it displays the temperature settings. When change the setting temperature, this indicator begins to flash, and stops 20 seconds later.

It displays the room temperature when the air conditioner is in FAN only operation.

When the unit stops operation, it returns to original factory settings.

Displays the malfunction code or protection code.

#### 11.1.9. FAN SPEED indication lamp

Displays the selected fan speed: AUTO(nothing) and three fan speed levels: LOW, MED and HIGH.

## 11.2. Protection

11.2.1. 3 minutes delay at restart for compressor.

11.2.2. Temperature protection of compressor top, compressor stops when the temp. of top of compressor is more than 115°C, compressor runs when the temp. of top of compressor is less than 100°C.

11.2.3. Voltage protection, unit stop when the voltage is more than 260V and less than 175V.

11.2.4. Inverter module Protection, Inverter module Protection itself has a protection function against current, voltage and temperature.

11.2.5. Sensor protection at open circuit and breaking disconnection

11.2.6. Fan Speed is out of control. When Indoor Fan Speed is too high (higher than 2100RPM) or too low (lower than 300RPM), the unit stops and LED displays failure information and can't return to normal operation automatically.

11.2.7. Cross Zero signal error warning. If there is no Cross Zero signals in 4 minutes, the unit stops and LED displays failure information and can't return to normal operation automatically.

## 11.3. Fan-only mode

Fan speed is high/mid/low/ Auto

## 11.4. Cooling mode

11.4.1. The 4-way valve is closed at cooling mode.

11.4.2. The action of the compressor and the outdoor fan:

	Condition T=Indoor Temp.	Compressor	Outdoor fan
Room temp. up	T > Ts+1	On	On
	T < Ts+1	Off	Off
Room temp. down	T > Ts	On	On
	T < Ts	Off	Off

11.4.3 Auto fan at cooling mode:

	Condition T=Indoor Temp.-Setting Temp.	Indoor fan speed
Room temp. up	T < 1.5°C	Low
	1.5°C < T < 4°C	Mid.
	T > 4°C	High
Room temp. down	T > 3°C	High
	1°C < T < 3°C	Mid.
	T < 1°C	Low

11.4.4 Anti-freezing control to indoor evaporator at cooling mode( T: evaporator temp. )

	Evaporator Temp.	Compressor
	0°C < T < 4°C	Decrease frequency of compressor
	T < 0°C	Off

11.4.5 Current protection

	Model	Current	Compressor
Current up	MSH-18HRIN1	I > 18 A	Off
		14.5A < I < 18A	Decrease frequency of compressor
		I < 12.0A	On
Current down	MSH-18HRIN1	I > 17.5 A	Off
		14.0A < I < 17.5A	Decrease frequency of compressor
		I < 11.5A	On

11.4.6 Rated capacity test

Set mode to cooling mode

Set temp. to 17°C  
 Set fan speed to high speed  
 Push turbo button 5 times in 10 seconds.  
 Using special remoter controller  
 After 5 hours, cancel rated capacity test  
 Turbo function  
 Increasing frequency of compressor  
 After operating 30 minutes, return automatically to the mode and temp. previously selected.

### 11.5. Dehumidifying mode

- 11.5.1 The 4-way valve is off  
 11.5.2 The indoor fan is fixed in breeze speed  
 11.5.3 Compressor run in low frequency  
 11.5.4 Low room temperature protection:  
 11.5.5 When room temperature decreases to below 10°C, compressor and outdoor fan will stop(indoor fan is Breeze). Dehumidifying operation will be resumed when room temperature restores to over 12°C.  
 11.5.6 At dehumidifying mode, the anti-freezing function of the indoor heat exchanger is the same as that of cooling mode.

### 11.6. Heating mode

- 11.6.1. Generally, the 4-way valve is open at heating mode, but it is closed at defrosting. 4-way valve must delay 2 minutes compared with compressor if the compressor changed into non-heating mode or turned off. 4-way valve doesn't delay in dehumidifying mode.  
 11.6.2. Generally, the outdoor fan is turned off with the on-off action of compressor in heating mode, except for the defrosting mode or the end of defrost.  
 11.6.3. Action of compressor and outdoor fan motor at heating mode: compressor must run for 7 minutes after starting and then judge temperature. Meanwhile other protections are still valid.

	Condition	Compressor	Outdoor fan
Room temp. up	$T > T_s + 3$	Off	Off
	$T < T_s + 3$	On	On
Room temp. down	$T < T_s + 2$	On	On
	$T > T_s + 2$	Off	Off

#### 11.6.4. Indoor Fan actions at heating mode

Indoor Fan can be set at HIGH/MID/LOW/AUTO by using a remote controller, but Anti-cold wind function prevails.

#### Anti-cold wind control function at heating mode

	Condition (T= Indoor exchanger temp.)	Indoor fan speed
Indoor exchanger temp. up	$T < 34^\circ\text{C}$	Off
	$34^\circ\text{C} < T < 37^\circ\text{C}$	Breeze
	$37^\circ\text{C} < T < 44^\circ\text{C}$	Low speed
	$T > 44^\circ\text{C}$	Setting fan speed
Indoor exchanger temp. down	$T > 38^\circ\text{C}$	Setting fan speed
	$33^\circ\text{C} < T < 38^\circ\text{C}$	Low speed
	$24^\circ\text{C} < T < 33^\circ\text{C}$	Breeze
	$T < 24^\circ\text{C}$	Off

When the indoor temp. gets to setting temp, indoor changes to breeze speed immediately, after 127 second, indoor fan stop.

#### 11.6.5. Auto wind at heating mode

	Condition (T=Indoor Temp.-Setting Temp.)	Indoor fan speed
Room temp. up	$T < 1.5^\circ\text{C}$	High
	$1.5^\circ\text{C} < T < 2.5^\circ\text{C}$	Med.
	$T > 2.5^\circ\text{C}$	Low

Room temp. down	T<1.0℃	High
	1.0℃<T<2.0℃	Med.
	T>2.0℃	Low

## 11.6.6. Indoor evaporator high-temperature protection at heating mode

Condition (T= Indoor exchanger temp.)	Compressor
T<48℃	On
53℃<T<63℃	Decrease frequency of compressor
T>63℃	Off

## 11.6.7. The current protection

	Model	Current	Compressor
Current up	18000btu/h	I>19.0 A	Off
		15.0.A<I<19.0A	Decrease frequency of compressor
		I< 12.5A	On
Current down	18000btu/h	I>18.5 A	Off
		14.5A<I<18.5A	Decrease frequency of compressor
		I< 12.0A	On

## 11.6.8. The temp. compensation

## Jump setting in indoor PCB

J2	On	On	Off	Off
J3	On	Off	On	Off
ΔT	0℃	-4℃	-2℃	0℃

**11.7. Defrosting operation (Available for heating only).**

## 11.7.1 Defrosting condition:

## 11.7.1.1. When outdoor temp. is more than 0℃,

Defrosting starts when meeting one of the following conditions,

- a. The temperature of outdoor heat exchanger remains consecutively lower than 3℃ for more than 40 minutes, and the temperature remains consecutively -4℃ for more than 3 minutes,
- b. The temperature of outdoor heat exchanger remains consecutively lower than 3℃ for more than 80 minutes, and the temperature remains consecutively -2℃ for more than 3 minutes

## 11.7.1.2. When outdoor temp. is less than 0℃,

Defrosting starts when meeting one of the following conditions,

- a. The temperature of outdoor heat exchanger remains consecutively lower than 3℃ for more than 40 minutes, and the temperature remains consecutively -6℃ for more than 3 minutes,
- b. The temperature of outdoor heat exchanger remains consecutively lower than 3℃ for more than 40 minutes, and the temperature remains consecutively -6℃ for more than 3 minutes,
- c. The temperature of indoor unit pipe decreases 5℃ than before

## 11.7.1.3. The temperature of outdoor heat exchanger remains consecutively lower than 3℃ for more than 120 minutes, and the temperature remains consecutively -2℃ for more than 3 minutes

## 11.7.2 Ending condition of defrosting

If one of following conditions is satisfied, end the defrost and turn into heating mode:

- a. The defrost time has reached to 10 minutes.
- b. When the temperature of outdoor heat exchanger rises up to 8℃ and this continues for more than 80 seconds.
- c. When the temperature of outdoor heat exchanger rises up to 12℃

11.7.3 Defrosting Actions:

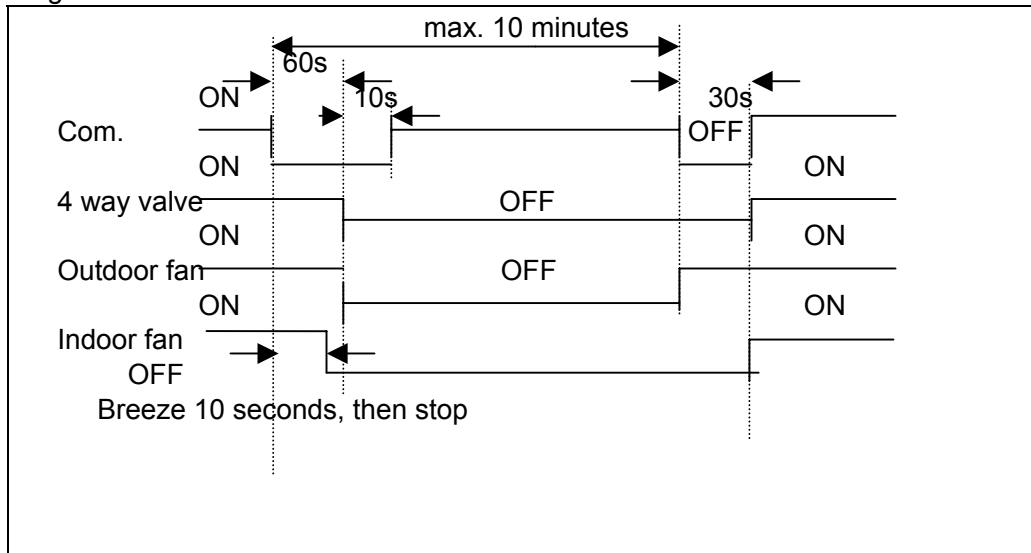

11.7.4 Rated capacity test

- Set mode to cooling mode
- Set temp. to 30 °C
- Set fan speed to high speed
- Push turbo button 5 times in 10 seconds.
- Using special remoter controller
- After 5 hours, cancel rated capacity test

**11.8. Outdoor low temperature protection (optional)**

Factory standard unit has not this function.

Unit stops when outdoor temp. is low than -15°C and lasting time more than 60 minutes, and unit runs again when outdoor temp. more than -12°C.

When indoor PCB J1 jump is on, this function is available.

**11.9. Automatic operation mode**

The air conditioner automatically selects one of the following operation modes: cooling, heating or fan only according to the temp. difference between room temp. (TA) and set temp. (TS).

TA—TS	Operation mode
TA—TS>2°C	Cooling
-1°C≤TA-TS≤+2°C	Fan-only
TA-TS<-1°C	Heating (air-only for cooling only type)

**11.10. Manual switch**

11.10.1 Mode changes when push this button .

Cooling mode→ Auto mode→Unit off→ Cooling mode

11.10.2 At Cooling mode, after 30 minutes cooling operation whose fan speed is set as low, the A/C operates with a setting temp. of 24°C.

11.10.3 At auto mode, the A/C operates with a set temp. of 24°C

**11.11. Timer Function**

11.11.1 The maximum length of timer is 24 hours and the minimum resolving power is 15 minutes.

11.11.2 Timer on: first turn off the A/C, the A/C will be automatically on at the set time.

11.11.3 Timer off: first turn on the A/C, the A/C will be automatically off at the set time

11.11.4 Timer on/off function( on time is earlier than off time): first turn off the A/C, it will be automatically on at set time, and later be off at the set time, then unit turns on at set time.

11.11.5 Timer off/on function( off time is earlier than on time): first turn on the A/C, it will be automatically off at set time, and later be on at the set time, then unit turns off at set time.

**11.12. Sleep mode**

11.12.1 It is available at cooling, heating or auto mode.

11.12.2 Cooling:

The set temperature rise 1°C per hour. Two hours later, the set temperature will maintain as a constant and the fan speed is kept at low speed.



11.12.3 Heating:

The set temperature decrease 1°C per hour. Two hours later, the set temperature will maintain as a constant and the air circulation is kept at low speed (Cold air proof function takes precedence over all).

11.12.4 Auto:

The Sleep Mode running function operates in accordance with selected running mode by auto mode.

11.12.5 After 7 hours, unit cancels this modes automatically.

**11.13. Auto restart function**

In case of a sudden power failure, this function automatically sets the unit to previous settings before the power failure when power returns.

**11.14. Turbo function**

The indoor fan will work in super high speed, the frequency of compressor will increase, the max run time is 30 minutes. After 30 minutes, the unit will work in previous setting.

**12. Model and Parameters**

Model	MSC-09HRDN1	MSC-12HRDN1	MSH-09HRDN1	MSH-12HRDN1
RACFAN	1300	1250	1200	1250
RAHFAN	1300	1300	1300	1300
RATIFC	60	74	57	74
RATIFH	55	77	57	77
SLEEPTIMC	7	7	7	7
FANCSHIGH	1300	1250	1200	1250
FANHSHIGH	1300	1300	1300	1300
FANCHIGH	1250	1250	1200	1250
FANHHIGH	1250	1300	1300	1300
FANMID	1100	1000	1000	1000
FANLOW	880	850	850	900
FANSLOW	800	700	700	700
F1	30	30	30	30
F2	38	38	38	38
F3	45	48	45	48
F4	52	57	52	57
F5	57	66	57	66
F6	64	76	64	76
F7	74	84	74	84
F8	86	90	86	90
F9	92	94	92	94
F10	96	98	96	98
I1COOL	6.0	6.5	6.0	6.5
I2COOL	7.0	8.3	7.0	8.3
I3COOL	8.5	9.5	8.5	9.5
I1HEAT	7.0	7.0	7.0	7.0
I2HEAT	8.5	9.0	8.5	9.0
I3HEAT	10.0	10.5	10.0	10.5
TCDI	-6	-6	-6	-6
TCDE1	12	12	12	12
TCDE2	8	8	8	8
TEL2	24	24	24	24
TEH2	53	53	53	53
ANGLSTART	200	193	200	200
ANGLOFF	110	101	106	125
ANGLHEATMAX	18	11	26	26
ANGLHEAT	27	17	38	40
ANGLHEATMIN	53	51	53	53
ANGLSMALL	0	0	0	0
ANGLCOOLMAX	186	180	195	195
ANGLCOOL	183	176	186	180
ANGLCOOLMIN	160	155	168	168
PDELAYCOUNT	127	127	127	127
V1	74	74	74	74
V2	45	45	45	45

## 13. Troubleshooting

### 13.1 Indoor Unit Error Display

Display	LED STATUS
E0	EEPROM error
E1	Indoor / outdoor units communication protection
E2	Zero-crossing examination error
E3	Fan speed beyond control
E5	Open or short circuit of outdoor temperature sensor
E6	Room temperature or evaporator temperature sensor open or short circuit of
P0	Module protection
P1	Over voltage or too low voltage protection
P2	Compressor top protection against temperature
P3	Outdoor low temp. protection
P4	Inverter compressor drive error

**Note: E4: Reserved function**

#### 13.1.1

Display	LED STATUS
E0	EEPROM parameter error

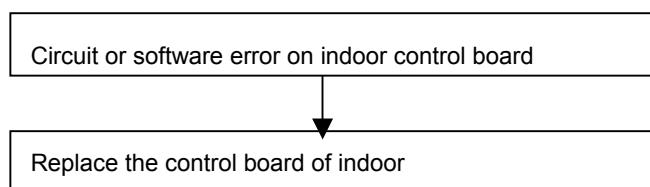

#### 13.1.2 circuit or software error on indoor control board

Display	LED STATUS
E1	Indoor / outdoor units communication protection

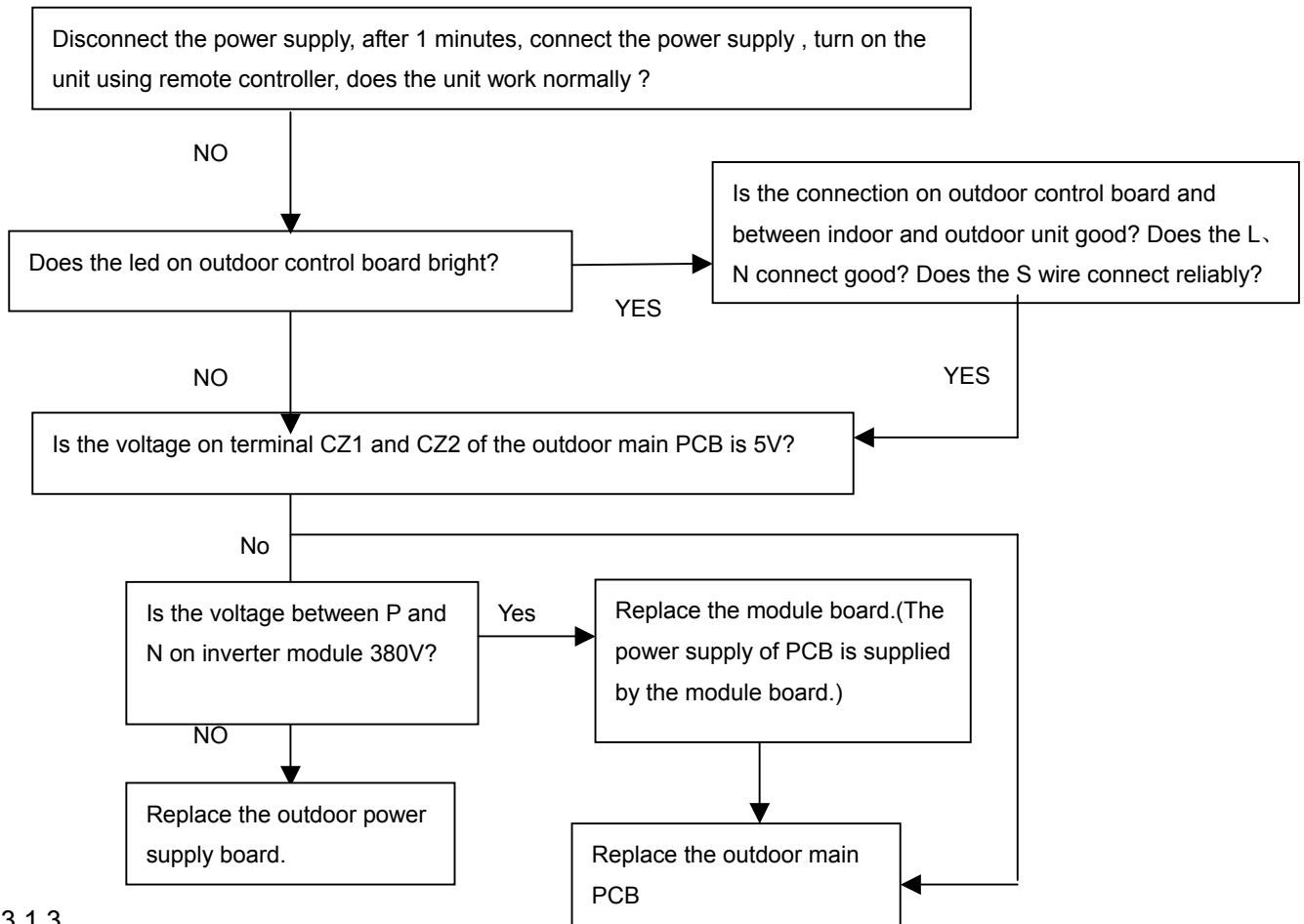

13.1.3

Display	LED STATUS
E2	Zero-crossing examination error

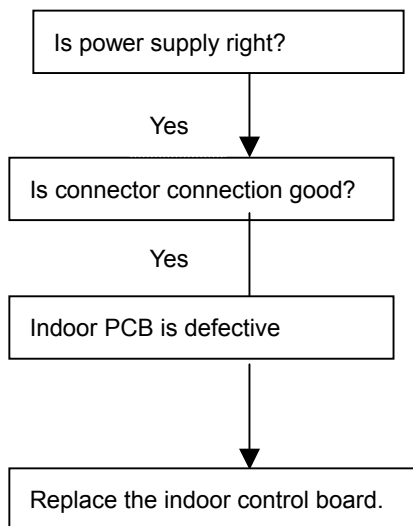

13.1.4

Display	LED STATUS
E3	Fan speed beyond control

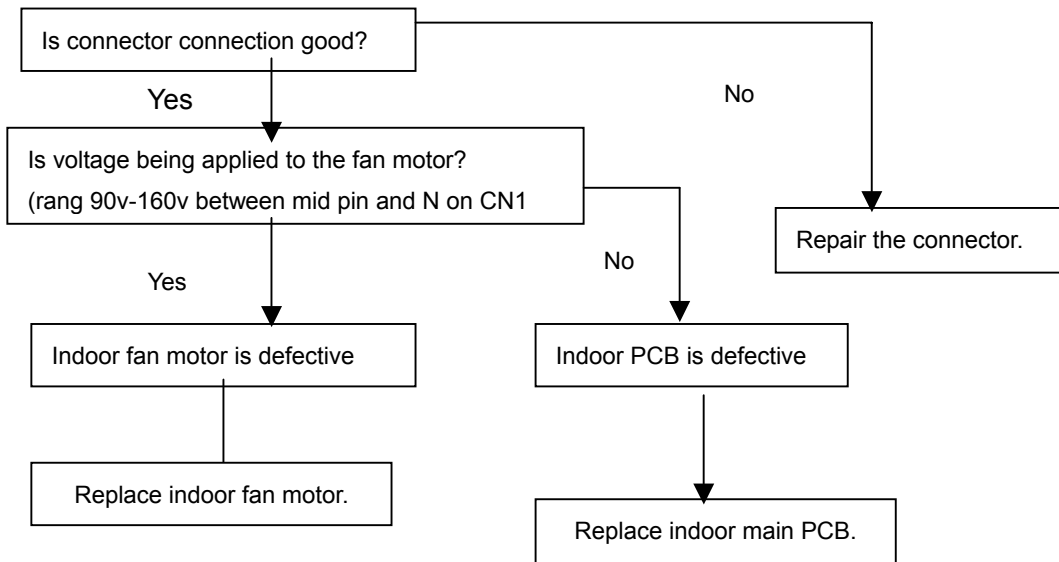

13.1.5

Display	LED STATUS
E5	Open or short circuit of outdoor temperature sensor

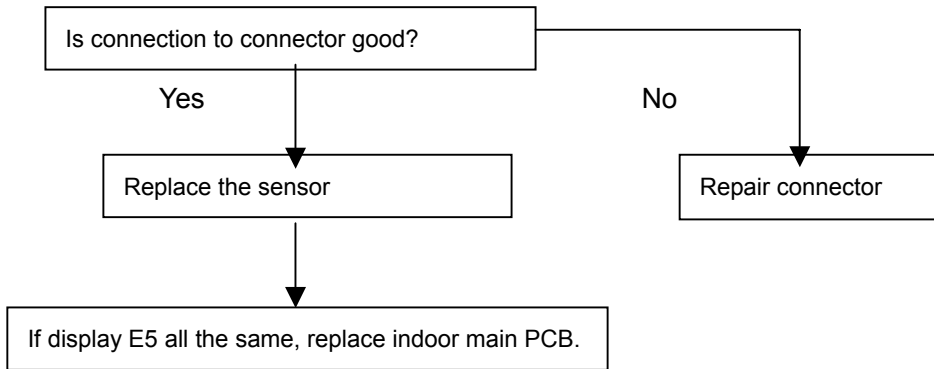

13.1.6

Display	LED STATUS
E6	Room temperature or evaporator temperature sensor open or short circuit

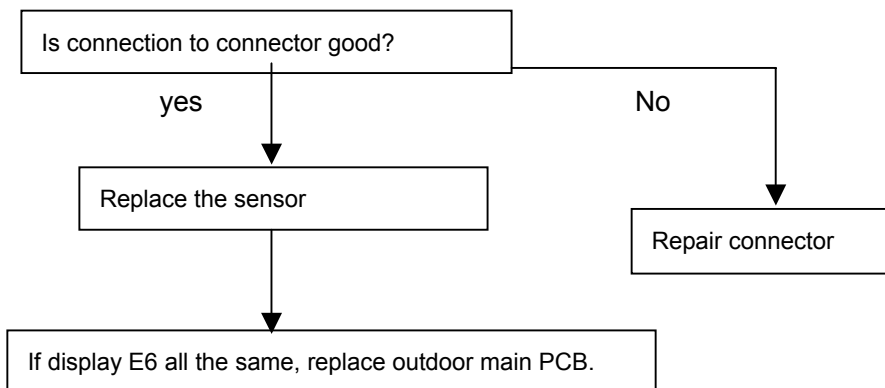

13.1.7

Display	LED STATUS
P0	Module protection

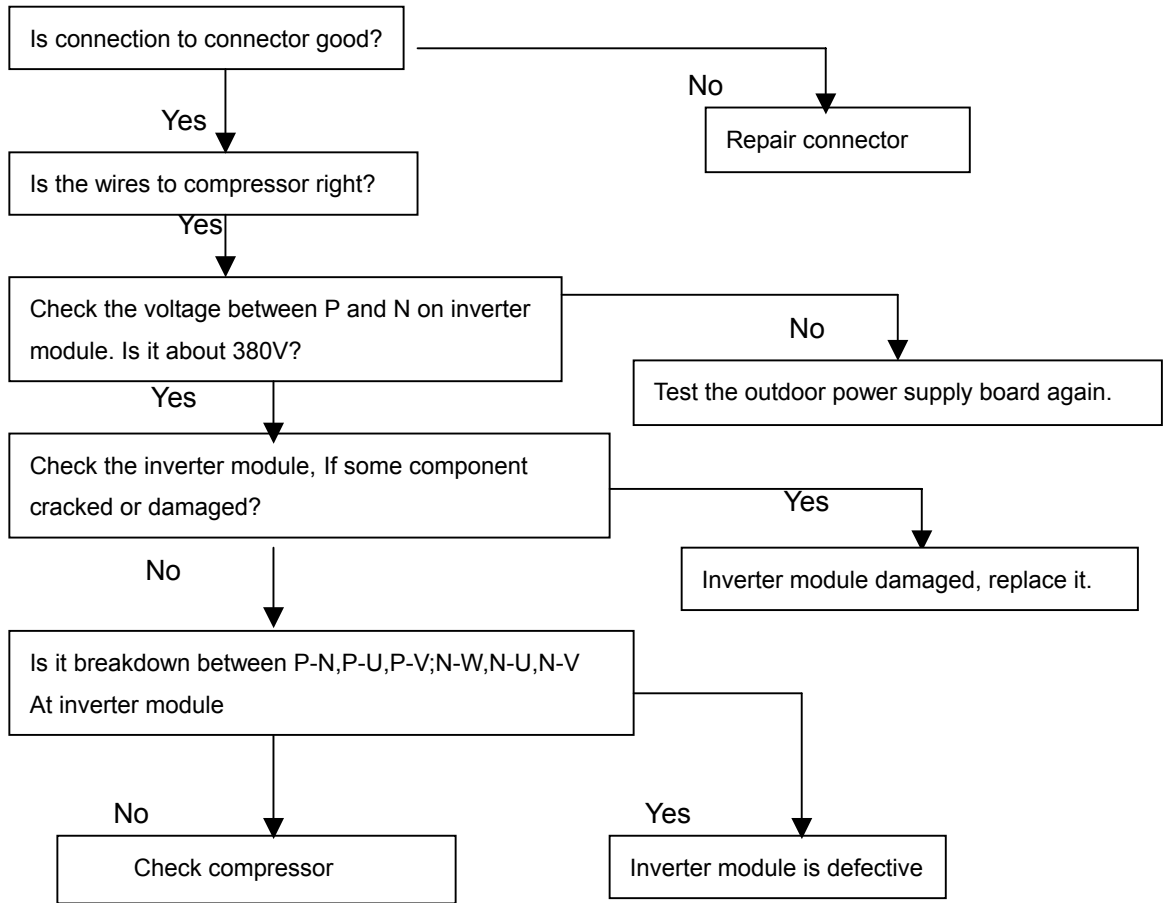

13.1.8

Display	LED STATUS
P1	Over voltage or too low voltage protection

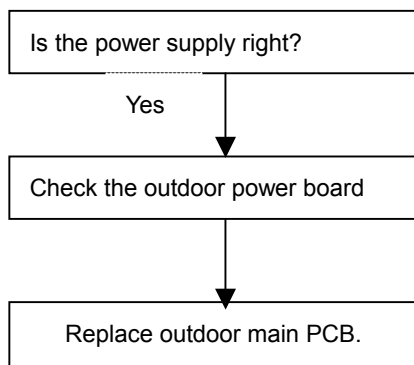

13.1.9

Display	LED STATUS
P2	Compressor top protection against temperature

Off: 115 °C; On: 100 °C

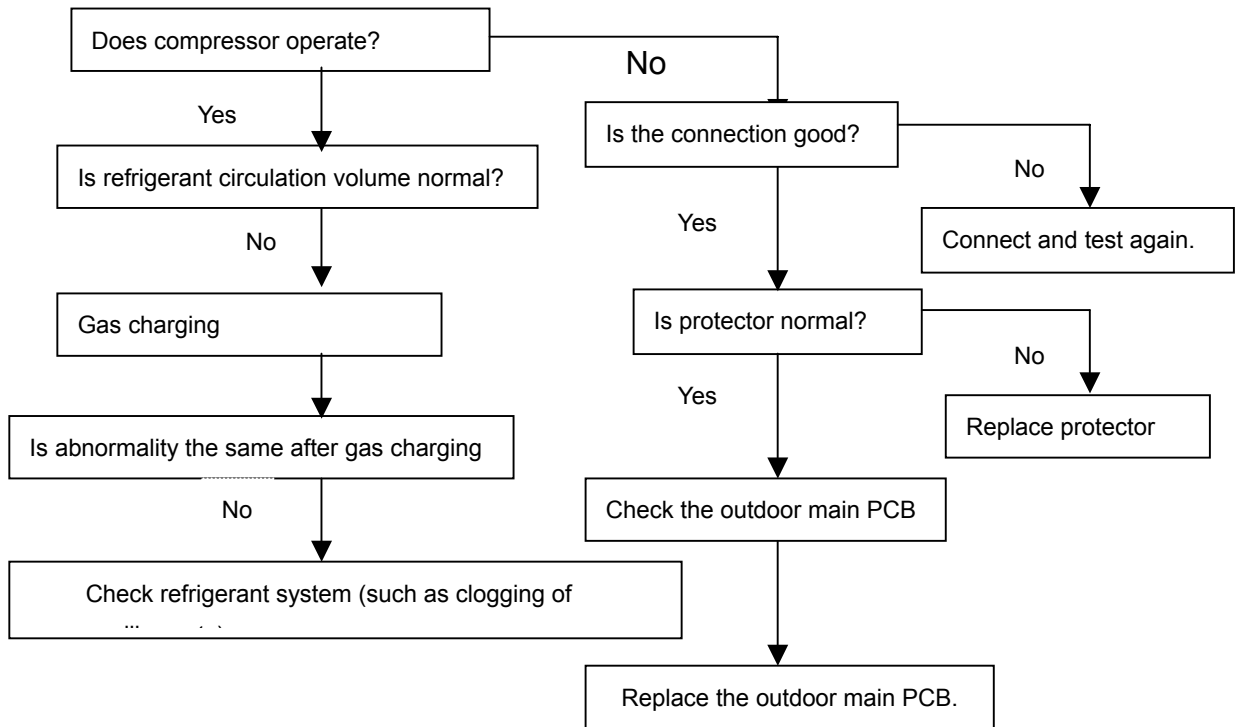

13.1.10

Display	LED STATUS
P3	Outdoor low temp. protection

This is optional, factory standard unit has not this function.

Unit stops when outdoor temp. is low than  $-15^{\circ}\text{C}$  and lasting time more than 60 minutes, and unit runs again when outdoor temp. more than  $-12^{\circ}\text{C}$ .

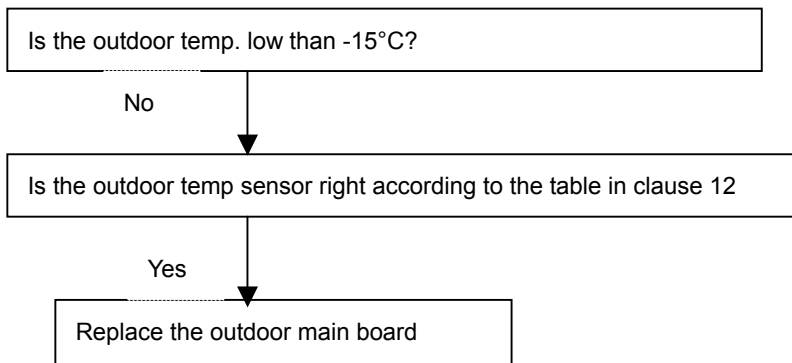

13.1.11

Display	LED STATUS
P4	Inverter compressor error

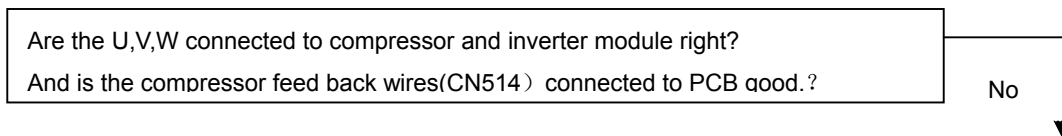

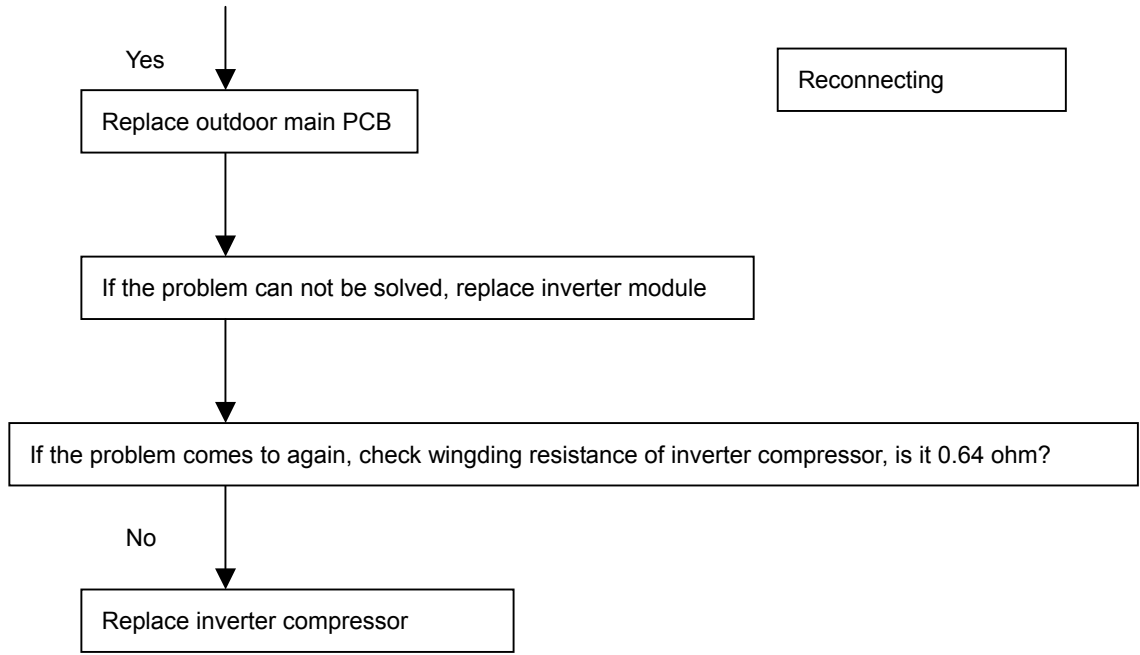

### 13.2 Diagnostic chart

After energizing, no indicator is lighted and the air conditioner can't be operated.



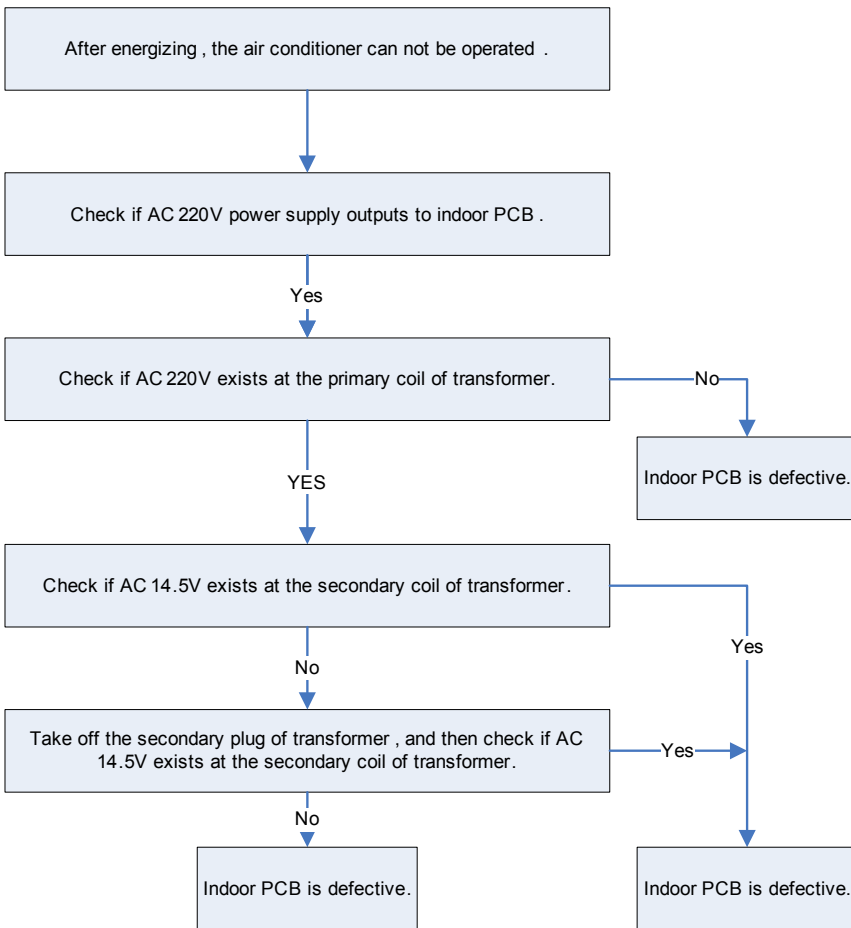

### 13.3 Resetting phenomenon often occurs during operation

(That is automatically entering to the status when power is on.)

The reason is that the instantaneous voltage of main chip is less than 4.5V. Check according to the following procedure:

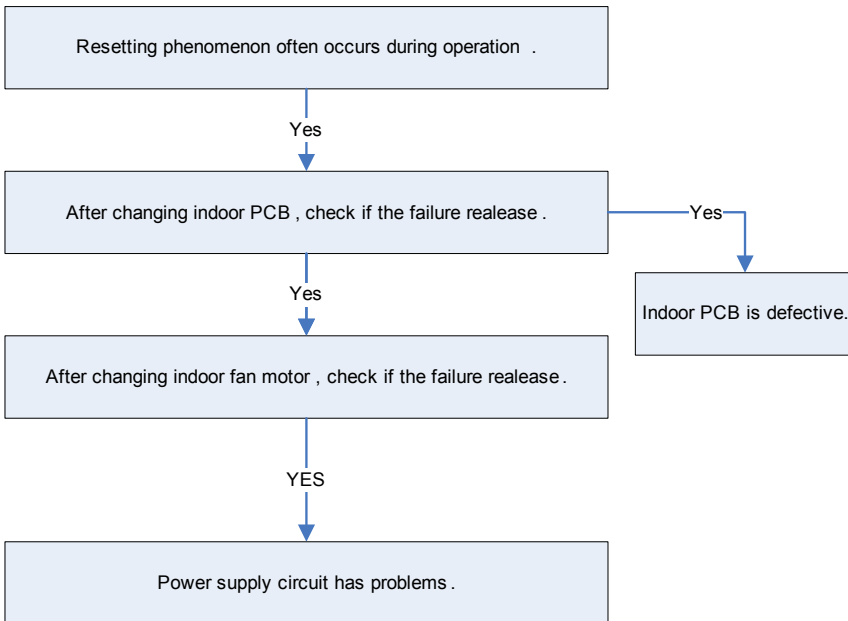

### 13.4 Operation lamp flashes and Timer lamp off

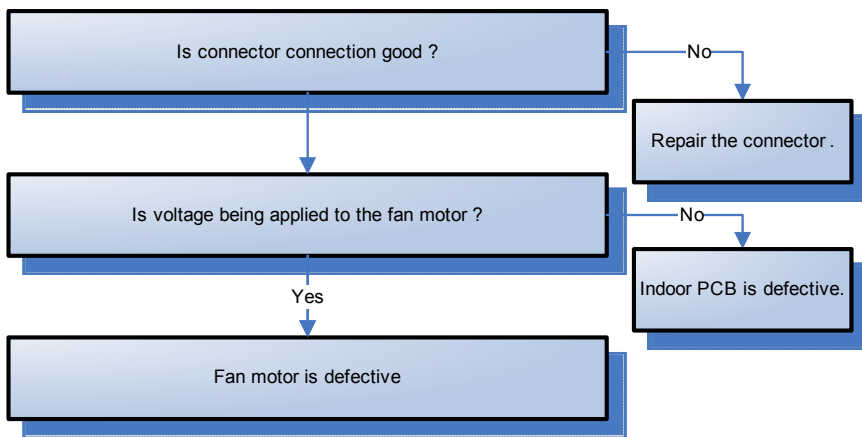

### 13.5 Operation lamp flashes and Timer lamp on

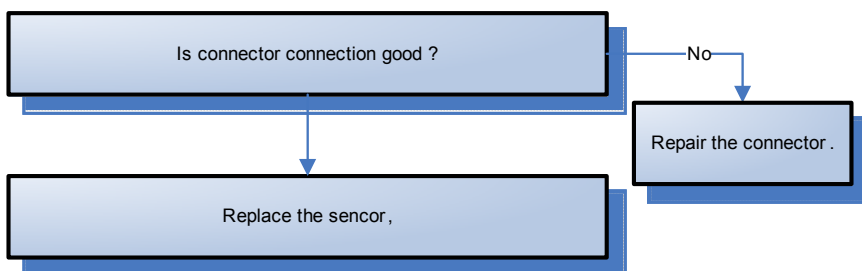

### 13.6 Operation lamp off and Timer lamp flashes

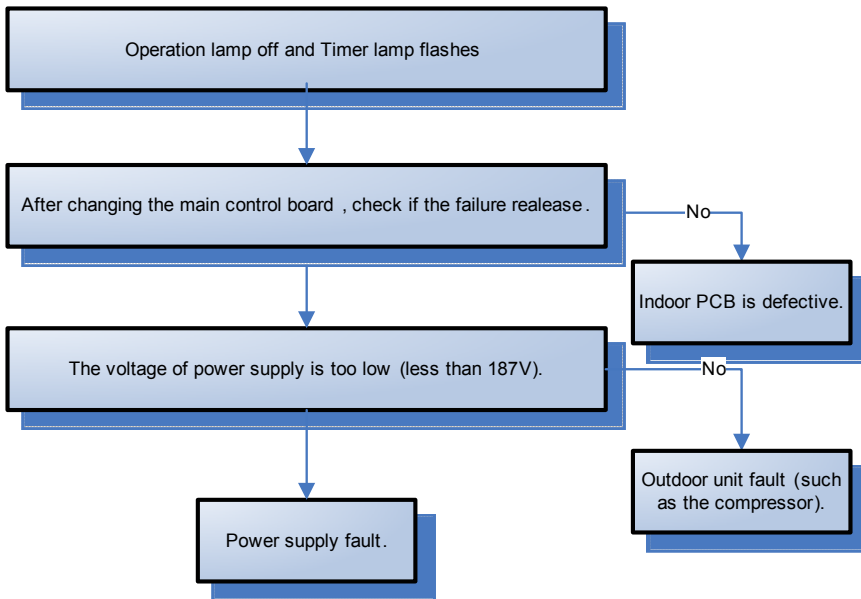

### 13.7 Operation lamp on and Timer lamp flashes

EEROM error, indoor PCB is defective.

### 13.8 Operation lamp flashes, Timer lamp flashes

This is alarm signal when the main chip can't detect over-zero signal. When such failure occurs, the main control board must have fault.

**14 Characteristic of temperature sensor**

Temp. °C	Resistance KΩ	Temp. °C	Resistance KΩ	Temp. °C	Resistance KΩ
-10	62.2756	17	14.6181	44	4.3874
-9	58.7079	18	13.918	45	4.2126
-8	56.3694	19	13.2631	46	4.0459
-7	52.2438	20	12.6431	47	3.8867
-6	49.3161	21	12.0561	48	3.7348
-5	46.5725	22	11.5	49	3.5896
-4	44	23	10.9731	50	3.451
-3	41.5878	24	10.4736	51	3.3185
-2	39.8239	25	10	52	3.1918
-1	37.1988	26	9.5507	53	3.0707
0	35.2024	27	9.1245	54	2.959
1	33.3269	28	8.7198	55	2.8442
2	31.5635	29	8.3357	56	2.7382
3	29.9058	30	7.9708	57	2.6368
4	28.3459	31	7.6241	58	2.5397
5	26.8778	32	7.2946	59	2.4468
6	25.4954	33	6.9814	60	2.3577
7	24.1932	34	6.6835	61	2.2725
8	22.5662	35	6.4002	62	2.1907
9	21.8094	36	6.1306	63	2.1124
10	20.7184	37	5.8736	64	2.0373
11	19.6891	38	5.6296	65	1.9653
12	18.7177	39	5.3969	66	1.8963
13	17.8005	40	5.1752	67	1.830
14	16.9341	41	4.9639	68	1.7665
15	16.1156	42	4.7625	69	1.7055
16	15.3418	43	4.5705	70	1.6469