

<b>SAFETY NOTICE</b>	<b>130001</b>

**Date:** April 29, 2013

**Models Affected:** GTH-1056 (see serial number list on page 3)

**Part Number Affected:** 117505 (Front Axle, Dana Model 213/142)

**Subject:** Service and Parking Brakes

**Allowable Hours:** 10 hours

---

**Issue:**

Genie was notified of a product service bulletin by Dana Corporation affecting Model 213/142 Drive Axles installed on the below referenced machines and sold as service parts replacement from July 26, 2012 to September 25, 2012. The service and parking brakes on these axles may malfunction due to improper assembly of the internal brake components. **Malfunctioning service and/or parking brakes may result in unintended machine movement, collision or loss of control.**

**Actions Required:**

This safety notice requires the inspection and possible repair of the brake assembly in the front axle installed on the affected machines or in your inventory.

1. Verify if your machine is affected by comparing the machine serial number to the serial number list on page 3.
2. If the machine is affected, immediately perform the actions described in the Procedure section on page 4 of this Safety Notice. If the machine is not affected, no further action is required.

For axles purchased as service parts replacement:

- If the axle is installed on a machine, immediately perform the actions described in the Procedure section on page 4 of this Safety Notice.
- If the axle is in your inventory, inspect the serial number of the axle. Follow the procedure section on page 4 starting at step 2.

**Continued Use:**

Machines affected by this safety notice may remain in service provided the test below is followed before and after each working shift until this safety notice is completed. This test procedure is best performed with two people.

1. Move the machine onto a firm level surface with the boom in the stowed position.
2. Engage the parking brake and set the transmission to neutral.
3. Engage the service brake and lower the stabilizers until both front tires are off the ground.

# SAFETY NOTICE

130001

4. Turn the engine off and set the key switch to the on position.
5. Release the service and parking brakes.
6. Have the second person stand in front of a tire and push on a lug with their foot (Illustration 1). It should spin with some effort. The other tire should turn in the opposite direction.



Illustration 1

7. Engage the parking brake and attempt to turn the same tire again.
  - The tires did not spin. The parking brake is functional.  
The machine may remain in service.  
Engage the service brakes and raise the stabilizers.
  - ⊗ The tires continue to spin. The parking brake is malfunctioning.  
Engage the service brake and raise the stabilizers. Chock the wheels.  
Remove the machine from service.
8. Repeat this test before and after each working shift until this safety notice is completed.
9. As always, follow all of the parking procedures listed in the operator's manual.

## Serial Numbers Affected:

GTH1012-15426      GTH1012-16360      GTH1012-16402      GTH1012-16446      GTH1012-16488

# SAFETY NOTICE

**130001**

GTH1012-15878	GTH1012-16364	GTH1012-16404	GTH1012-16448	GTH1012-16490
GTH1012-16299	GTH1012-16366	GTH1012-16406	GTH1012-16450	GTH1012-16492
GTH1012-16301	GTH1012-16367	GTH1012-16409	GTH1012-16451	GTH1012-16493
GTH1012-16303	GTH1012-16371	GTH1012-16411	GTH1012-16453	GTH1012-16495
GTH1012-16304	GTH1012-16373	GTH1012-16413	GTH1012-16455	GTH1012-16497
GTH1012-16311	GTH1012-16374	GTH1012-16415	GTH1012-16457	GTH1012-16499
GTH1012-16320	GTH1012-16376	GTH1012-16416	GTH1012-16458	GTH1012-16506
GTH1012-16322	GTH1012-16378	GTH1012-16418	GTH1012-16460	GTH1012-16516
GTH1012-16324	GTH1012-16380	GTH1012-16420	GTH1012-16462	GTH1012-16518
GTH1012-16332	GTH1012-16381	GTH1012-16422	GTH1012-16464	GTH1012-16520
GTH1012-16334	GTH1012-16383	GTH1012-16425	GTH1012-16467	GTH1012-16521
GTH1012-16336	GTH1012-16385	GTH1012-16427	GTH1012-16469	GTH1012-16523
GTH1012-16338	GTH1012-16387	GTH1012-16430	GTH1012-16471	GTH1012-16525
GTH1012-16339	GTH1012-16388	GTH1012-16432	GTH1012-16472	GTH1012-16527
GTH1012-16343	GTH1012-16390	GTH1012-16434	GTH1012-16476	GTH1012-16528
GTH1012-16346	GTH1012-16392	GTH1012-16436	GTH1012-16478	GTH1012-16530
GTH1012-16348	GTH1012-16394	GTH1012-16437	GTH1012-16479	GTH1012-16532
GTH1012-16353	GTH1012-16395	GTH1012-16439	GTH1012-16481	GTH1012-16534
GTH1012-16355	GTH1012-16397	GTH1012-16441	GTH1012-16483	
GTH1012-16357	GTH1012-16399	GTH1012-16443	GTH1012-16485	
GTH1012-16359	GTH1012-16401	GTH1012-16444	GTH1012-16486	

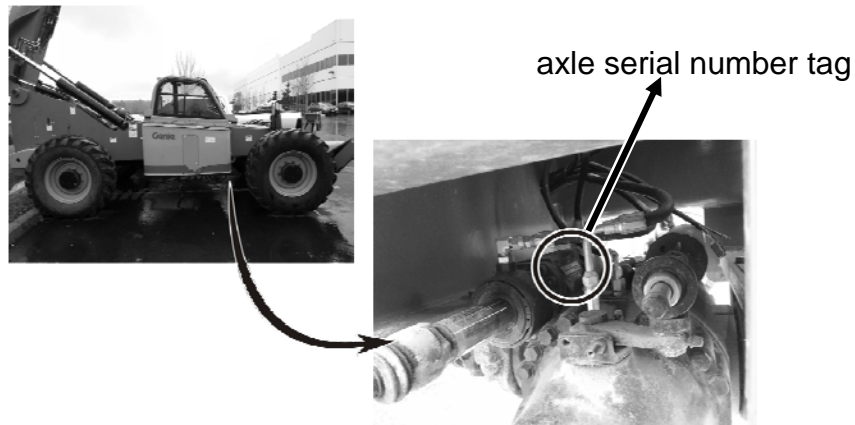
# SAFETY NOTICE

130001

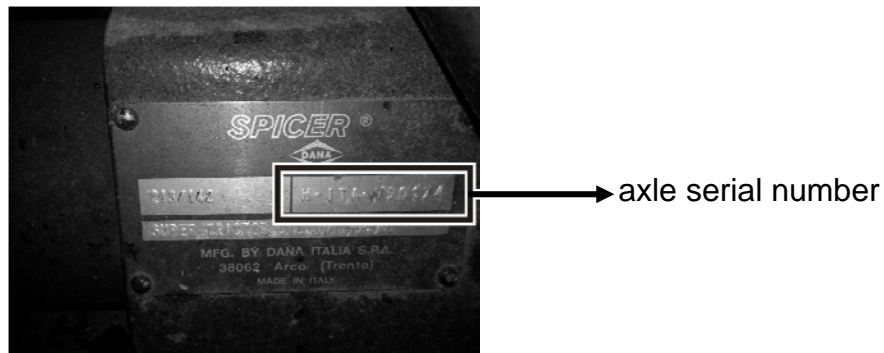
## Procedure – Inspection/Repair

A. Determine if the front axle installed on your machine is affected:

1. Locate the front axle serial number tag.



2. Inspect for the serial number stamped on the serial number tag. Use the attached axle serial number inspection form to record the axle serial number installed on your machine.



- If the axle serial number is in the affected list (see page 5), proceed to section B.
- ⊗ If the axle serial number is not in the affected list, fill out the “Completion Form for Inspection” and return to Genie. This will serve as verification that you have completed this safety notice. No further action is required.

List of affected axle serial numbers:

# SAFETY NOTICE

**130001**

R-ITA-729594	R-ITA-735523	R-ITA-735553	R-ITA-744459
R-ITA-729595	R-ITA-735524	R-ITA-735554	R-ITA-744460
R-ITA-729607	R-ITA-735525	R-ITA-740592	R-ITA-744462
R-ITA-729608	R-ITA-735526	R-ITA-740594	R-ITA-744464
R-ITA-729610	R-ITA-735527	R-ITA-740595	R-ITA-744465
R-ITA-729611	R-ITA-735528	R-ITA-740596	R-ITA-744466
R-ITA-731410	R-ITA-735529	R-ITA-740597	R-ITA-744467
R-ITA-731411	R-ITA-735530	R-ITA-740598	R-ITA-744468
R-ITA-731412	R-ITA-735531	R-ITA-740599	R-ITA-744469
R-ITA-731413	R-ITA-735532	R-ITA-740600	R-ITA-744470
R-ITA-731414	R-ITA-735533	R-ITA-740602	R-ITA-744471
R-ITA-731415	R-ITA-735534	R-ITA-740603	R-ITA-744472
R-ITA-731416	R-ITA-735535	R-ITA-740604	R-ITA-744473
R-ITA-731417	R-ITA-735536	R-ITA-740605	R-ITA-744474
R-ITA-731418	R-ITA-735537	R-ITA-740606	R-ITA-744475
R-ITA-731419	R-ITA-735538	R-ITA-744442	R-ITA-744476
R-ITA-731420	R-ITA-735539	R-ITA-744443	R-ITA-744477
R-ITA-731421	R-ITA-735540	R-ITA-744444	R-ITA-744478
R-ITA-731422	R-ITA-735541	R-ITA-744445	R-ITA-744479
R-ITA-731423	R-ITA-735542	R-ITA-744446	R-ITA-744480
R-ITA-731424	R-ITA-735543	R-ITA-744447	R-ITA-744481
R-ITA-731425	R-ITA-735544	R-ITA-744448	R-ITA-744482
R-ITA-735515	R-ITA-735545	R-ITA-744449	R-ITA-744483
R-ITA-735516	R-ITA-735546	R-ITA-744450	R-ITA-744484
R-ITA-735517	R-ITA-735547	R-ITA-744451	R-ITA-744485
R-ITA-735518	R-ITA-735548	R-ITA-744452	R-ITA-744486
R-ITA-735519	R-ITA-735549	R-ITA-744453	R-ITA-751717
R-ITA-735520	R-ITA-735550	R-ITA-744454	R-ITA-751722
R-ITA-735521	R-ITA-735551	R-ITA-744455	R-ITA-751736
R-ITA-735522	R-ITA-735552	R-ITA-744458	R-ITA-754077

# SAFETY NOTICE

130001

## B. Inspection and repair of the brake discs on affected axle.

Genie and the axle supplier have determined that the nature and complexity of the inspection and repair to be performed requires special training and tooling. Use the option below that best fits your situation.

### Option 1:

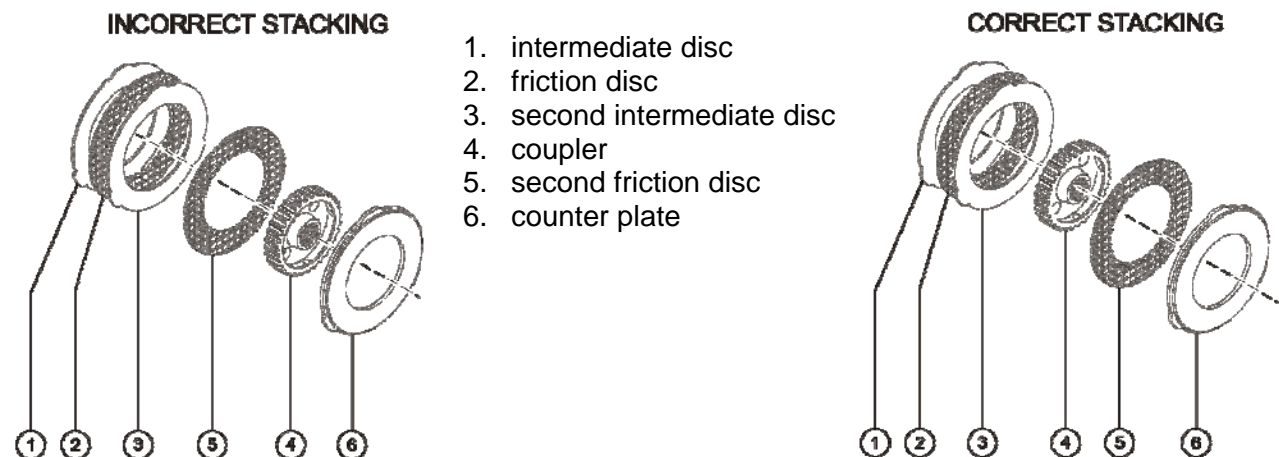
You can have your machine inspected and repaired by one of Terex's service centers. Just locate and call the nearest Terex Service North America location and schedule an appointment. Refer to the attached Terex Service North America map.

### Option 2:

The procedure requires the removal and disassembly of the front axle on your machine. You will need the following tools to perform this.

- Lifting straps capable of supporting 2000 lb / 1000 kg or greater
- Overhead crane capable of supporting 2000 lb / 1000 kg or greater
- Jack stands or blocks capable of supporting 10 ton / 10,000 kg or greater
- Assorted wrenches
- Assorted impact sockets
- Impact wrench
- Instruction 822725 (attached)

For more information on this procedure, contact Genie's service department @ 1-800-536-1800 ext. 6818 and refer to SN 130001.



# SAFETY NOTICE

130001

## Reimbursement:

Only Genie Dealers will be reimbursed for labor or any other costs associated with this bulletin under the provisions of our LIMITED PRODUCT WARRANTY statement.

Machine owners without a valid Genie account can contact their nearest Terex AWP dealership or Terex Service North America for assistance.

Search for your nearest Terex AWP dealership by visiting our website at:

<http://www.genielift.com/dealersearch/>

## Warranty:

The labor and travel miles required to perform this inspection and installation are covered under the provisions of our LIMITED PRODUCT WARRANTY statement. Warranty claims can be submitted by paper claims, fax or email. If you need more information about filing a warranty claim, call Terex AWP Warranty department.

Genie and ANSI requires that the seller of a Genie machine report to Genie the model and serial number of each machine sold, as well as the name, address, and telephone number of the new owner, within 60 days of the sale. OSHA and ANSI also require that the manufacturer's safety notices be completed. It is your responsibility to communicate this important information to all machine owners and applicable branches. If you require additional copies of this safety notice or have any questions, please contact Genie's service department at:

United States	800-536-1800
Canada	425-881-1800
Europe	+31 653 221 908
Australia	61 733751660
All other locations	001-425-881-1800

## Enclosures:

- Machine List Report
- New Owner Update Form
- Completion Form for Inspection
- Map, Terex Service North America
- Instruction - 822725



# Safety Notice 130001

## New Owner Update Form (for updating machine owner information only)

Genie and ANSI requires that the seller of a Genie machine report to Genie the model and serial number of each machine sold, as well as the name, address, and telephone number of the new owner, within 60 days of the sale.

- If you have sold a machine, list the complete model and serial number (examples: GTH1012-16303 or GTH1012-16418) and the name, address and phone number of the new owner.

**New Owner Information:**

	Machine 1	Machine 2	Machine 3
Model*	_____	_____	_____
Serial Number*	_____	_____	_____
Owner Name*	_____	_____	_____
Address 1*	_____	_____	_____
Address 2	_____	_____	_____
City/State/Zip*	_____	_____	_____
Phone Number*	_____	_____	_____
Contact Person	_____	_____	_____

\* Required fields.

**Seller Information:**

Date: \_\_\_\_\_

Company Name: \_\_\_\_\_

Account #: \_\_\_\_\_

Address: \_\_\_\_\_

(street) \_\_\_\_\_

(city) \_\_\_\_\_

State, zip code \_\_\_\_\_

Phone #: \_\_\_\_\_

- List any machines that could not be inspected or repaired because of the following:

Model & Serial Number	Scrapped	Exported	Stolen	Others (explain)
_____	-	-	-	-
_____	-	-	-	-
_____	-	-	-	-
_____	-	-	-	-

**Fax to:**

United States	877-738-7530
Canada	425-498-7530
All other locations	001-425-498-7530





Safety Notice 130001

**Completion Form for Inspection**

---

Your signature on this form will verify that the front axle (Genie P/N 117505) installed on your machine and/or in you inventory have been inspected and verified to be **not affected** by this Safety Notice.

---

- List the complete model and serial number (examples: GTH1012-16303 or GTH1012-16418) model of the machine inspected or the invoice number of the front axle in your inventory.

Machine Model / Invoice number	Build Date / Invoice Date	Machine Serial Number <small>(indicate "inventory" if the axle is in your inventory)</small>	Front Axle Serial Number <small>("N/A" if the axle is in your inventory)</small>

Date: \_\_\_\_\_

Company Name: \_\_\_\_\_

Account #: \_\_\_\_\_

Address: \_\_\_\_\_

(street) \_\_\_\_\_

(city) \_\_\_\_\_

State, zip code \_\_\_\_\_

Phone #: \_\_\_\_\_

---

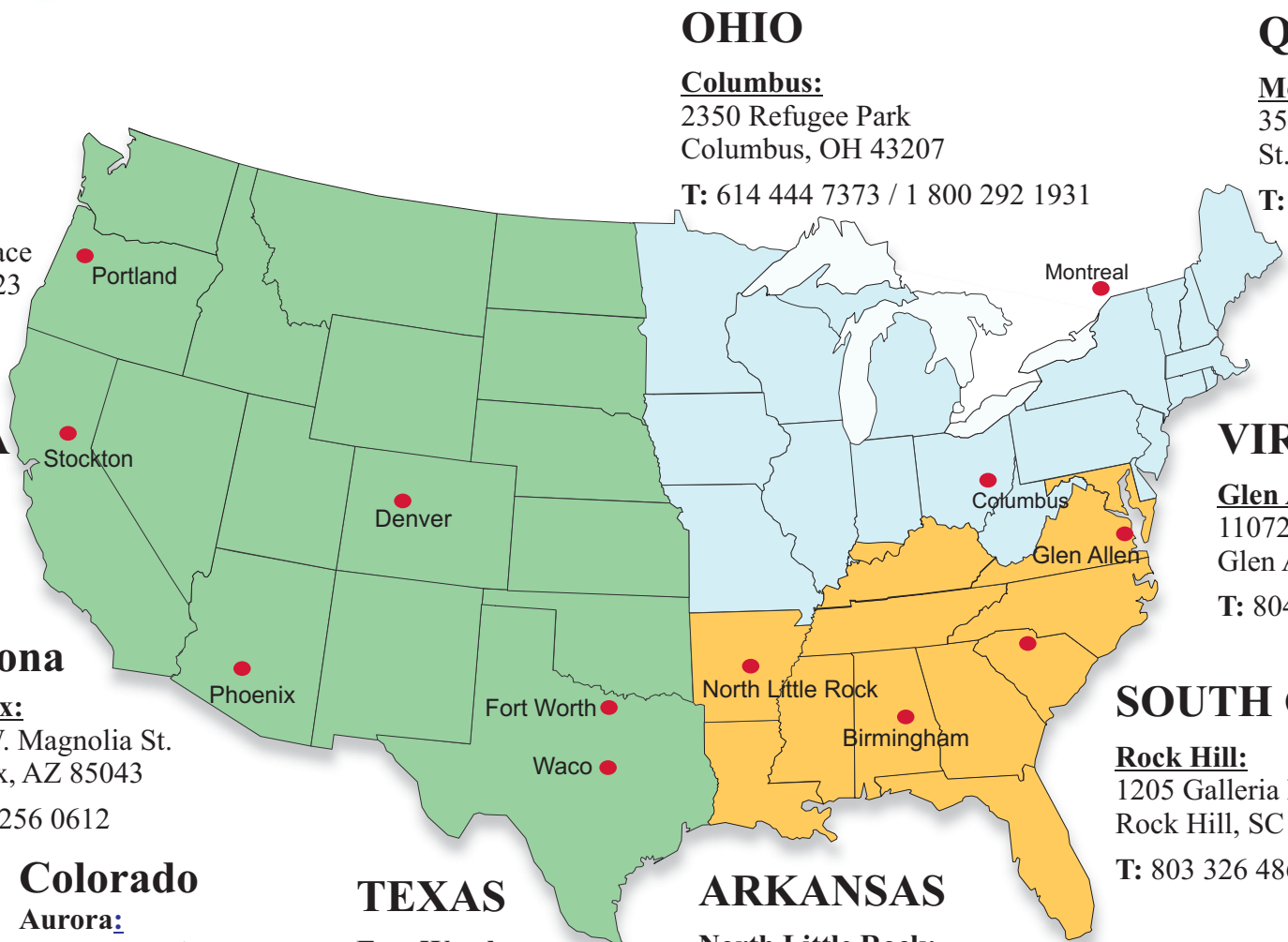
Service Manager (Print Name)

---

Signature

Fax to:           United States           877-738-7530  
                   Canada                 425-498-7530  
                   All other locations       001-425-498-7530

E-mail:           [AWP.Warranty@terex.com](mailto:AWP.Warranty@terex.com)



## OREGON

**Portland:**  
12805 SE 77th Place  
Portland, OR 97223  
T: 503 620 0611

## CALIFORNIA

**Stockton:**  
2610 Lycoming St.  
Stockton, CA 95206  
T: 209 652 0103

## Arizona

**Phoenix:**  
4920 W. Magnolia St.  
Phoenix, AZ 85043  
T: 605 256 0612

## Colorado

**Aurora:**  
18000 E 22nd Ave.  
Aurora, CO 80011  
T: 303 202 0304

## TEXAS

**Fort Worth:**  
1300 S Sylvania Ave.  
Fort Worth, TX 76111  
T: 817 698 8005

**Waco:**  
7911 Panther Way  
Waco, TX 76712  
T: 254 714 0088

## OHIO

**Columbus:**  
2350 Refugee Park  
Columbus, OH 43207  
T: 614 444 7373 / 1 800 292 1931

## ARKANSAS

**North Little Rock:**  
309 Dixie St.  
N. Little Rock, AR 72114  
T: 501 945 6100

## Quebec

**Montreal:**  
3524 Rue Ashby  
St. Laurent, QC H4R 2C1  
T: 514-336 5556

## VIRGINIA

**Glen Allen:**  
11072 Washington Hwy  
Glen Allen, VA 23059  
T: 804-752 2811

## SOUTH CAROLINA

**Rock Hill:**  
1205 Galleria Blvd  
Rock Hill, SC 29730  
T: 803 326 4869

## ALABAMA

**Birmingham:**  
4120 Lewisburg Rd  
Birmingham, AL 35207  
T: 205 985 5200 / 1 800 800 6411



# ***Inspection Instructions***

## ***Brake Inspection***

***GTH-1056***

Part No. 822725

Rev A

---

# Introduction



## Observe and Obey:

- This procedure shall be completed by a person trained and qualified on the repair of this machine.
- Immediately tag and remove from service a damaged or malfunctioning machine.
- Repair any machine damage or malfunction before operating the machine.

## Before Starting Installation:

- Read, understand and obey the safety rules and operating instructions in the appropriate operator's manual.
- Be sure that all necessary tools and parts are available and ready for use.
- Read this procedure completely and adhere to the instructions. Attempting shortcuts may produce hazardous conditions.
- Indicates that a specific result is expected after performing a series of steps.
- Indicates that an incorrect result has occurred after performing a series of steps.

**Note: These installation instructions only apply to the Genie models listed below, as required by Safety Notice 130001.**

- GTH-1056

## Tools required:

Lifting straps capable of supporting 2000 lb / 1000 kg or greater

Overhead crane capable of supporting 2000 lb / 1000 kg or greater

Jack stands or Blocks capable of supporting 10 ton / 10,000 kg or greater

Assorted wrenches

Assorted impact sockets

Impact wrench

# Procedure

Note: Perform this procedure on a firm, level surface with the boom in the stowed position. Chock the rear wheels.

## How to Remove the Front Axle

**⚠ WARNING** Bodily injury hazard. This procedure requires specific repair skills, lifting equipment and a suitable workshop. Attempting this procedure without these skills and tools could result in death or serious injury and significant component damage. Dealer service is required.

- 1 Loosen the lug nuts of both wheels on the axle to be removed. Do not remove the lug nuts
- 2 Start the machine. Fully lower the outriggers. Turn off the machine and remove the key.
- 3 Place jack stands or blocks under the front chassis for support.

**⚠ DANGER** Crushing hazard. The chassis will fall if not properly supported.

- 4 Remove the lug nuts. Remove the tire and wheel assembly from both ends of the axle.
- 5 Remove the fasteners securing the front drive shaft to the transmission. Lower the end of the drive shaft to the ground.
- 6 Remove the fasteners securing the drive shaft to the front axle. Remove the drive shaft from the machine.
- 7 Support and secure the axle to an overhead crane.

- 8 Remove the fasteners securing the sway cylinder rod-end pivot pin to the chassis.
- 9 Use a soft metal drift to remove the pivot pin.
- 10 Remove the fasteners securing the axle to the chassis. Remove the axle from the machine.

**⚠ DANGER** Crushing hazard. The axle will fall if not properly supported when the fasteners are removed from the machine.

---

### Bolt torque specification

---

Axle mounting bolts	380 ft-lbs 515 Nm
---------------------	----------------------

---

## Confirm the Proper Brake and Coupler Stacking Order

Follow the procedure to disassemble the axle using the *Dana 213 Axle Maintenance and Repair* information included with these instructions.

**Note: Refer to the illustration on page 5 for the correct stacking order.**

# Procedure

- 11 Install the axle, drive shaft, and tire and wheel assembly.
- 12 Remove the jack stands or blocks.
- 13 Start the machine and fully raise the outriggers. Turn the machine off.
- 14 Torque the lug nuts to 465 ft-lbs / 630 Nm.

## Test the Brakes:

- 15 Step on the brake pedal and start the machine.
- 16 Push the bottom of the parking brake switch. The parking brake is off when the indicator light is off.
- 17 Move the transmission control lever to forward. Slowly let up on the brake pedal. As soon as the machine starts to move, push the brake pedal.
  - ⊙ Result: The machine should move forward, and then come to an abrupt stop.
- 18 Move the transmission control lever to reverse. Slowly let up on the brake pedal. As soon as the machine starts to move, push the brake pedal.
  - ⊙ Result: The machine should move in reverse, and then come to an abrupt stop. The back-up alarm should sound when the transmission control lever is in reverse.
- 19 Move the transmission control lever to neutral.
- 20 Push the top of the parking brake switch.
  - ⊙ Result: The red parking brake indicator light should come on, indicating the parking brake is on.

- 21 Move the transmission control lever forward, and then in reverse.

⊙ Result: The machine should not move.

- 22 Perform function test. Refer to the Operator's Manual on your machine.

- 23 Return the machine to service.

- 24 Fill out and sign the attached completion form and fax or email to Terex AWP Warranty Department. This will serve as verification that you have completed Safety Notice 130001.

If you have any further questions regarding these instructions or need assistance, please contact the Genie Service Department at one of the following telephone numbers:

United States: 800-536-1800

Canada: 425-881-1800

Europe: UK 0044 1476 584 333

France 0033 237 260 986

Germany 49 4221 491 821

Iberica 0034 935 725 090

Italy 0039 075 941 8132

Scandinavia 0046 3157 5154

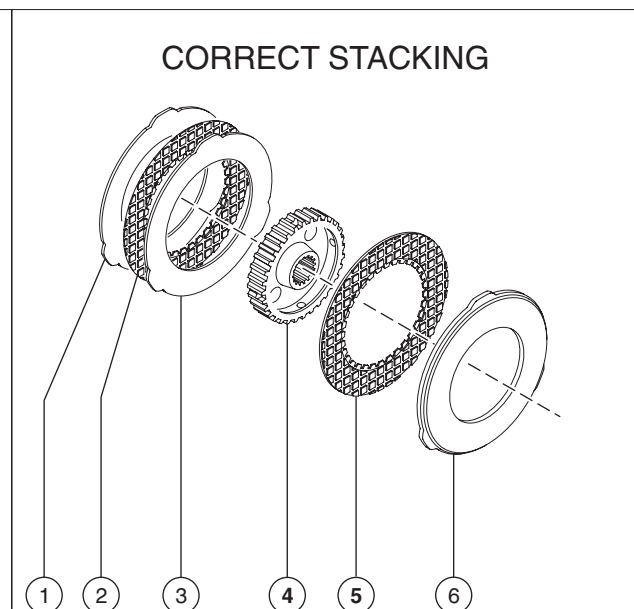
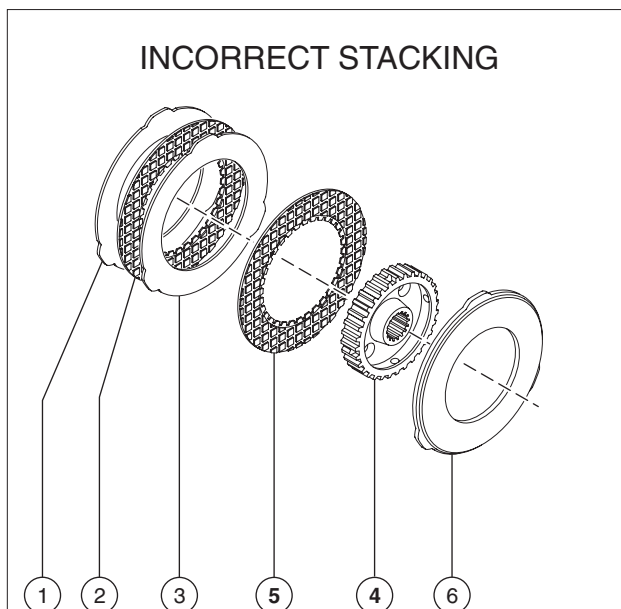
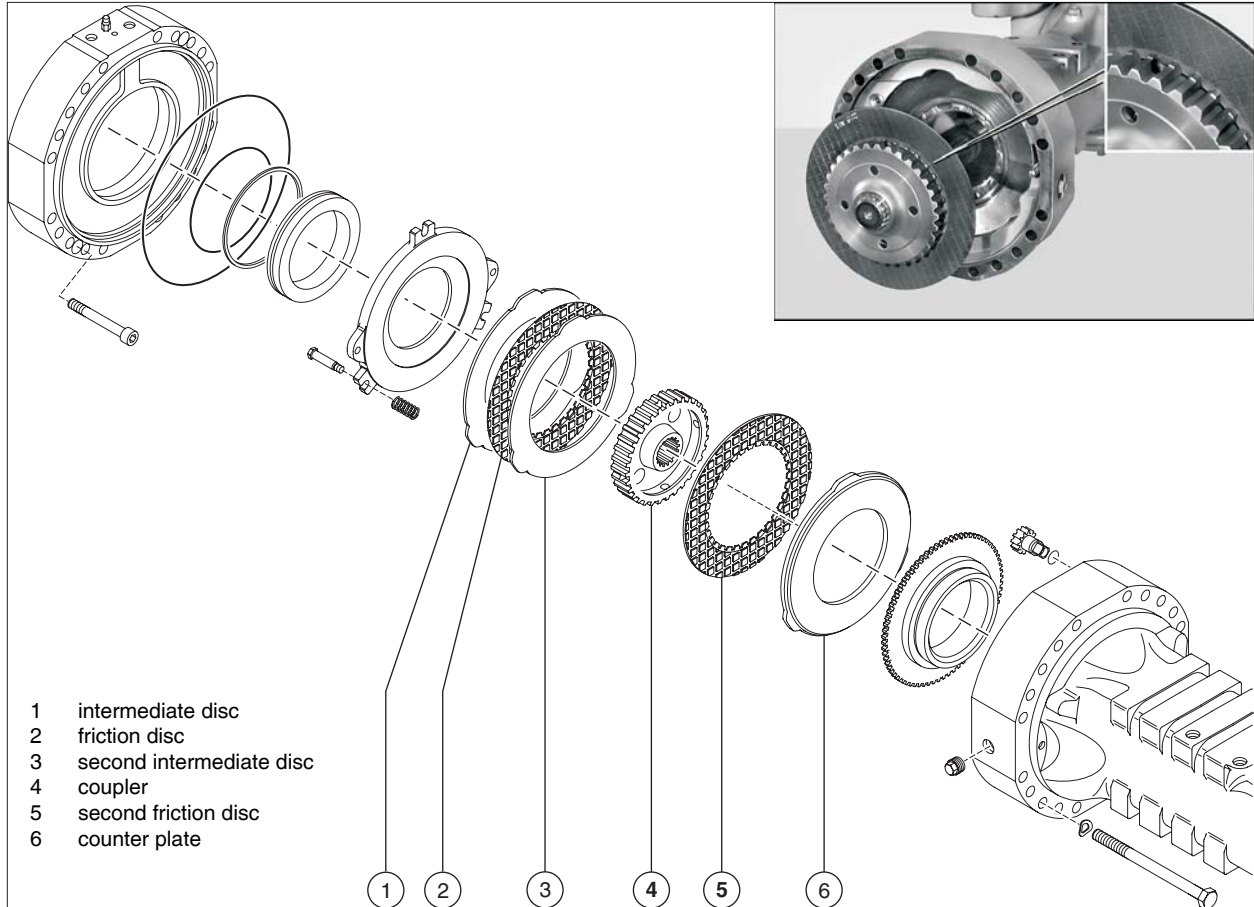
Other locations 0031 653 221 908

Middle East: 0097 143 391 800  
or 0097 150 459 7937

Australia: 61 7 3456 4444

All other locations 001-425-881-1800

# Illustration



This page intentionally left blank.





**SAFETY NOTICE 130001**

**Completion Form**

---

Your signature on this form will verify that you have completed the brake inspection.

<b>Fax to:</b> United States	877-738-7530	United Kingdom	0044 1476 584 330
Canada	425-498-7530	France	0033 237 260 998
Australia	61 733751002	Germany	0049 4221 491 820
All other locations	001-425-498-7530	Italy	0039 075 941 8146
		Iberica	0034 935 725 080
		Sweden	0046 3157 5104
		Middle East	0097 143 990 382
		All other locations	0031 165 510 826

Email to: [AWP.Warranty@terex.com](mailto:AWP.Warranty@terex.com)

Date: \_\_\_\_\_

Company Name: \_\_\_\_\_

Account # (if applicable) \_\_\_\_\_

Address: \_\_\_\_\_

(street) \_\_\_\_\_

(city) \_\_\_\_\_

(state, zip code) \_\_\_\_\_

Phone \_\_\_\_\_

Please list the complete serial number (example: GTH1011-15238 or GTH1012-16472).

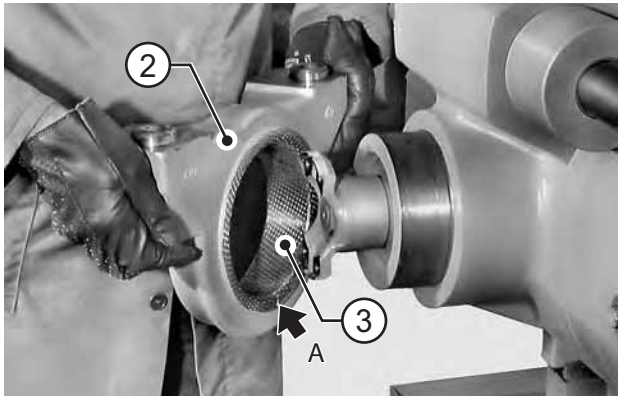
Machine Serial Number: _____	Axle Serial Number (if replacement is required): _____
_____	_____
_____	_____
_____	_____
_____	_____

Print (service manager)	Signature	Date
-------------------------	-----------	------



# DISASSEMBLY

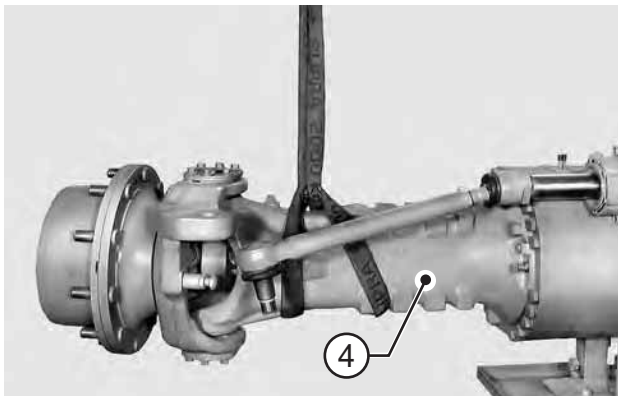
## DISASSEMBLY



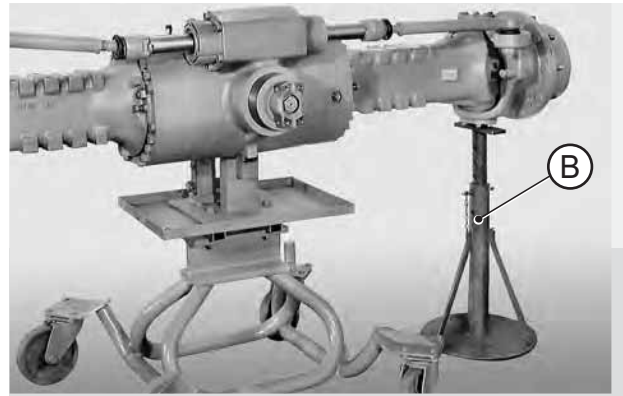
**FIGURE 1: REPLACING DISCS**  
Remove the rocking support (2) from non-drive end.

### **NOTE:**

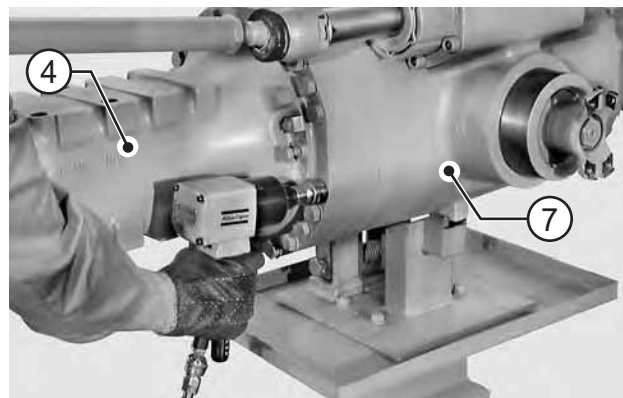
If bushing (3) will be replaced because it is worn, write down direction of installation of joint split "A".



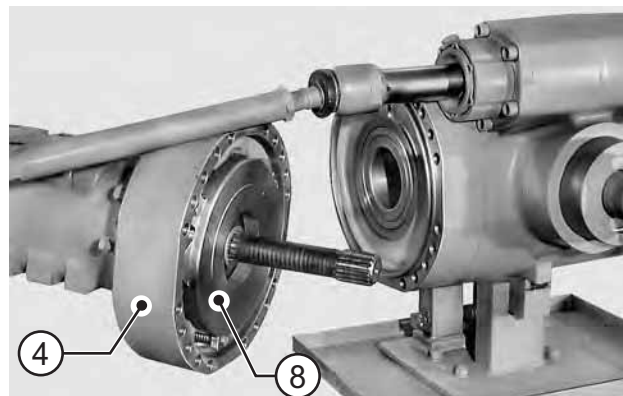
**FIGURE 2: Disconnect steering bar pivots from the steering cases** (See STEERING CYLINDER p. 61).  
Sling arm (4) to be removed and slightly tighten the sling rope.



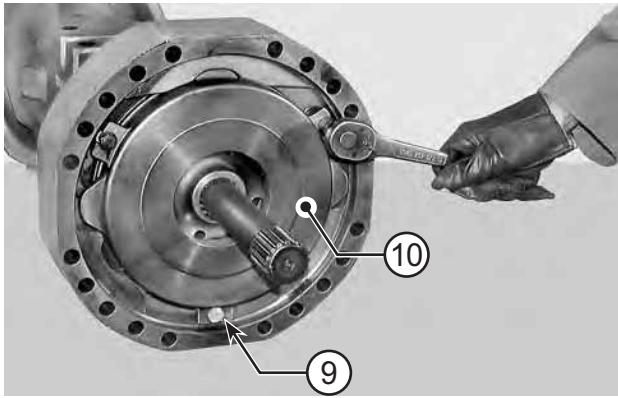
**FIGURE 3: If axle is positioned on an overhaul bench, place a safety anti-tilting stand "B" under the arm that remains connected and block wheels, if any.**



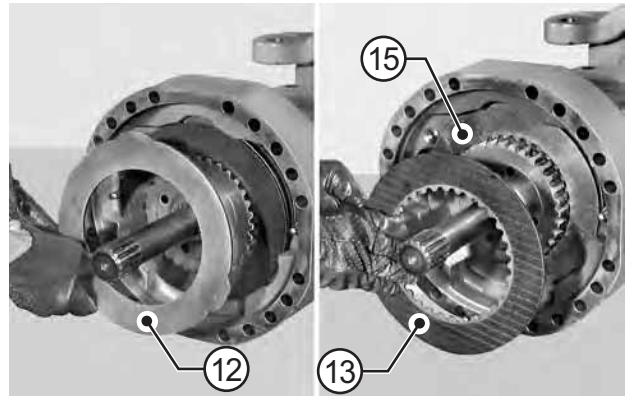
**FIGURE 4: Loosen and remove the screws (5) and washers (6) that fix the arm (4) to the main body (7).**



**FIGURE 5: Remove arm (4) along with brake discs pack (8). Lay the arm on a workbench.**



**FIGURE 6:** Loosen check and guide screws (9) of thrust disc (10).



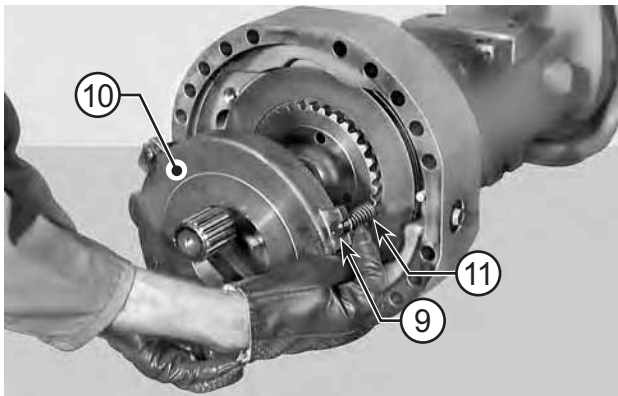
**FIGURE 8:** Remove in sequence: first intermediate disc (12), friction disc (13), and second intermediate disc (15).

## ⚠ CAUTION

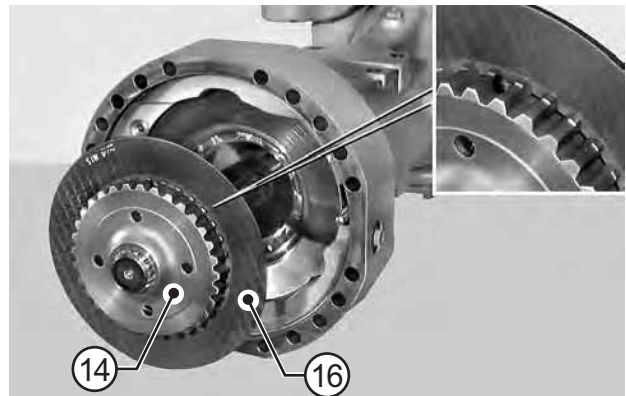
Loosen screws (9) in several stages, sequentially and slowly.

## ⚠ CAUTION

Check friction disc thickness; if thickness is 5 mm or less, replace discs on both sides.



**FIGURE 7:** Remove the thrust disc (10) along with screws (9) and springs (11).



**FIGURE 9:** Remove both coupling (14) and friction disc (16) at the same time.

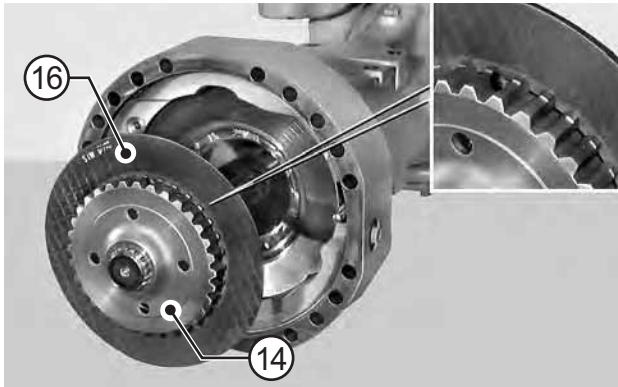
### 📌 NOTE:

Write down direction of installation.

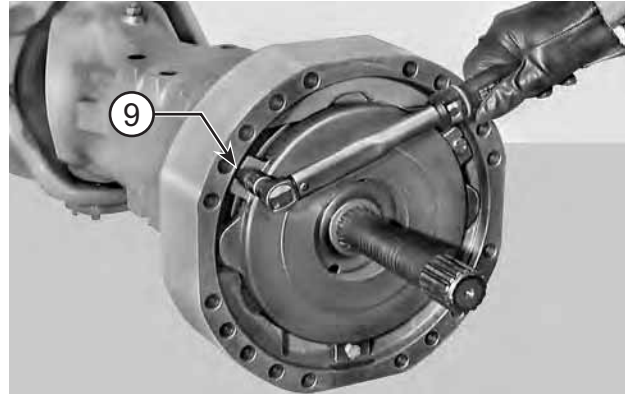
## ⚠ CAUTION

Write down direction of installation of coupling (14) in relation to brake disc (16).

# ASSEMBLY



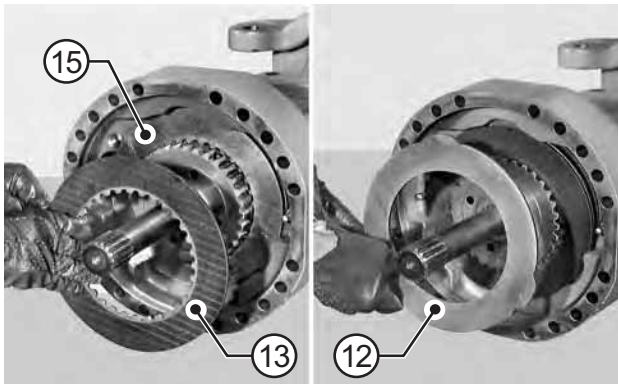
**FIGURE 30:** Lubricate the friction disc (16) with oil SAE 85W90; install friction disc and coupling (14).



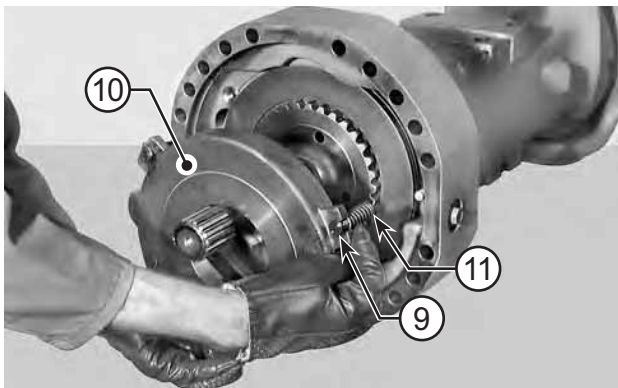
**FIGURE 33:** Tighten screws (9) sequentially and in several stages to a torque of 20 - 30 N·m.

## ⚠ CAUTION

Check coupling's direction of installation carefully.



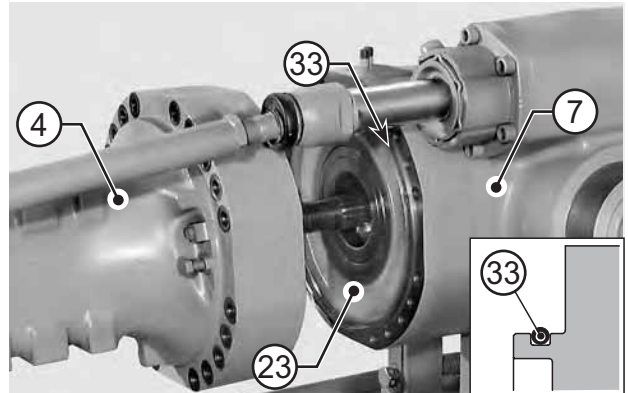
**FIGURE 31:** Install parts in the following sequence: intermediate disc (15), friction disc (13), and second intermediate disc (12).



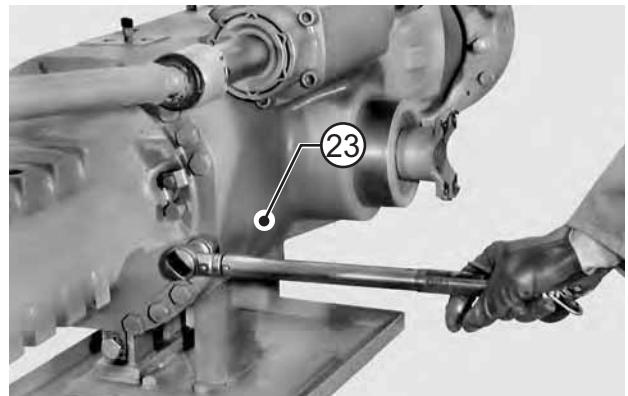
**FIGURE 32:** Install the thrust disc (10), springs (11), and screws (9).

## ⚠ CAUTION

Orient disc (10) to align on horizontal axis the negative brake release screws (36) recesses.



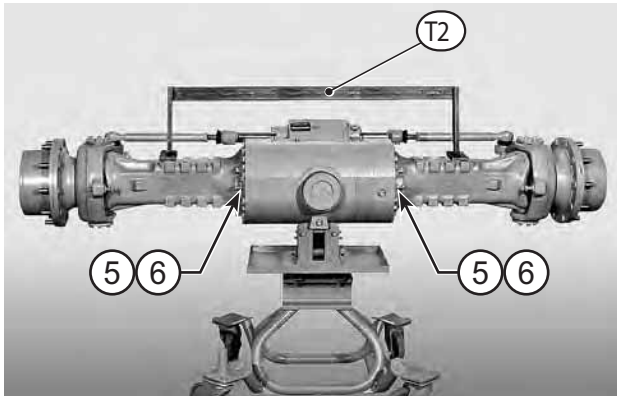
**FIGURE 34:** Fit a new o-ring (33) on the brake cylinder (23). Connect the complete arm (4) to a hoist and install it in the main body (7).



**FIGURE 35:** Fasten the arm to the brake cylinder (23) and attach the arm with screws and washers (6).

## 🔧 NOTE:

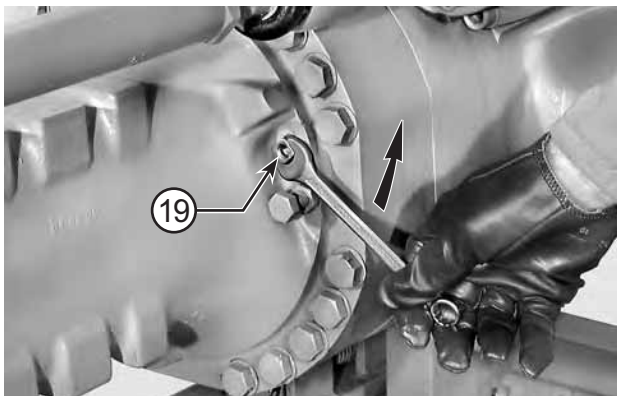
Tighten screws to make the coupling faces just touch each other.



**FIGURE 36:** Using tool T2 (See drawing T2 p. 26) check that the arms are level, then finally lock them with screws (5) and washers (6) using the criss-cross method. Tightening torque: 283 - 312 N·m.

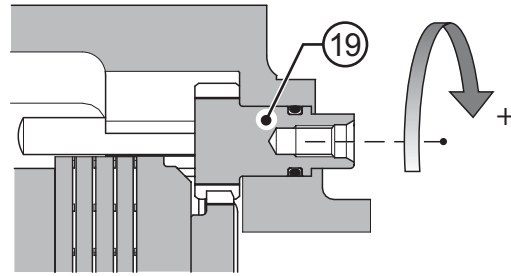


**FIGURE 37: ADJUSTING BRAKES**  
When adjusting the brakes, connect a hydraulic pump to the access hole of the negative brake and introduce pressure at 20 - 25 bar to release the brake disc.



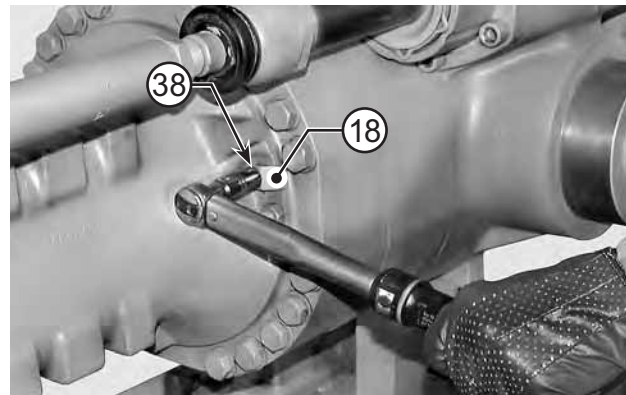
**FIGURE 38:** Rotate the pinion (19) counter-clockwise until it reaches the end of stroke and a slight torque is obtained.

**NOTE:**  
All existing clearances between discs are eliminated as a result of this operation.



**FIGURE 39:** Rotate pinion (19) clockwise to obtain the accurate clearance.  
Axles with two friction discs: 3 turns + 3 sides; clearance: 0.75 mm;  
Axles with three friction discs: 5 turns; clearance: 1 mm.

**NOTE:**  
Every turn of the pinion produces a clearance of 0.2 mm.



**FIGURE 40:** Release pressure, fit the catch (18) and lock with screw (38) coated with Loctite 242. Tighten screw to a torque of 20 - 30 N·m.