

HEATING AND AIR CONDITIONING

TABLE OF CONTENTS

	page	page
GENERAL INFORMATION		
A/C APPLICATION TABLE	2	
HEATER AND AIR CONDITIONING CONTROL . . .	2	
HEATER AND AIR CONDITIONING	2	
INTRODUCTION	3	
SAFETY PRECAUTIONS AND WARNINGS	4	
DESCRIPTION AND OPERATION		
A/C REFRIGERANT LINES	4	
BLOWER MOTOR RESISTOR	5	
COMPRESSOR	5	
COMPRESSOR FRONT SHAFT SEAL	6	
CONDENSATION DRAIN TUBE	6	
ENGINE COOLING SYSTEM REQUIREMENTS . . .	6	
EVAPORATOR PROBE	6	
HANDLING TUBING AND FITTINGS	6	
HIGH PRESSURE CUT OUT SWITCH	6	
LOW PRESSURE CUT OFF SWITCH	6	
SIDE WINDOW DEMISTERS	7	
SYSTEM AIRFLOW	7	
SYSTEM OIL LEVEL	7	
VACUUM CONTROL SYSTEM	8	
DIAGNOSIS AND TESTING		
A/C PERFORMANCE TEST	9	
BLOWER MOTOR ELECTRICAL DIAGNOSIS	9	
BLOWER MOTOR VIBRATION AND/OR NOISE DIAGNOSIS	11	
COMPRESSOR NOISE DIAGNOSIS	11	
EVAPORATOR PROBE TEST	11	
EXPANSION VALVE	11	
HEATER PERFORMANCE TEST	13	
LOW PRESSURE CUT OFF SWITCH	14	
SYSTEM CHARGE LEVEL TEST	14	
VACUUM CONTROL SYSTEM	15	
SERVICE PROCEDURES		
CHARGING A/C SYSTEM	17	
EVACUATING REFRIGERANT SYSTEM		18
R-134a REFRIGERANT		19
SERVICING REFRIGERANT OIL LEVEL		19
SYSTEM LEAK CHECKING		20
REMOVAL AND INSTALLATION		
A/C FILTER/DRIER		20
A/C SERVICE PORT VALVE CORES		21
BLOWER MOTOR AND WHEEL ASSEMBLY		21
BLOWER MOTOR RESISTOR		22
BLOWER MOTOR WHEEL		22
COMPRESSOR		22
COMPRESSOR CLUTCH/COIL ASSEMBLY		23
CONDENSATION DRAIN TUBE		25
CONDENSER		25
DISCHARGE LINE		26
EVAPORATOR		26
EVAPORATOR PROBE		26
EXPANSION VALVE		27
HEATER CORE		28
HEATER HOSES		28
HIGH PRESSURE CUT OUT SWITCH		29
HIGH PRESSURE RELIEF VALVE		29
LIQUID LINE		29
LOW PRESSURE CUT OFF SWITCH		29
MODE CONTROL CABLE		30
RECIRCULATION DOOR ACTUATOR		31
SUCTION LINE		31
TEMPERATURE CONTROL CABLE		32
UNIT HOUSING		32
DISASSEMBLY AND ASSEMBLY		
HEATER-A/C HOUSING		34
ADJUSTMENTS		
MODE CONTROL CABLE		34
TEMPERATURE CONTROL CABLE		34

GENERAL INFORMATION

A/C APPLICATION TABLE

Item	Description	Notes
Vehicle	PL Neon	
System	expansion valve	
Total Refrigerant Capacity	R134a	765 grams / 27 oz / 1.69 lbs
Total Oil Capacity	ND-8 PAG oil	180 ml / 6.10 oz
Compressor	Nippondenso 10S17	
Freeze-up Control	Fin sensor-3 wire	input to PCM, evaporator mounted, cycles clutch off below 34° F, cycles back on above 45° F
Low psi Control	opens < 14 psi, resets > 38 psi	expansion valve mounted
High psi Control	opens > 470 psi, resets < 370 - 330 psi	compressor mounted switch
Control head	manual type	
Mode Door	cable	
Blend Air Door	cable	
Fresh/Recirc door	vacuum actuator	
Blower Motor	control head switched	resistor block
Cooling Fan	variable speed	PCM controlled ISO solid state fan relay
Clutch		
Control	relay	PCM
Draw	2.5 amps @ 12V	± 0.5V @ 70° F
Gap	0.014" - 0.026"	
DRB III®		
Reads	TPS, RPM, A/C switch test, fin sensor A/C & fan relays	
Actuators	fan & clutch relays	

HEATER AND AIR CONDITIONING CONTROL

Both the heater-only and heater-A/C systems use a combination of, electrical, cable, and vacuum controls. These controls provide the vehicle operator with a number of setting options to help control the climate and comfort within the vehicle. Refer to the owner's manual in the vehicle glove box for more information on the features, use, and suggested operation of these controls.

The heater-only or heater-A/C control panel is located to the right of the instrument cluster on the instrument panel. The control panel contains rotary-type knobs. There is a blower motor speed switch, mode control switch, temperature control, and airflow control.

The heater-only or heater-A/C control panel cannot be repaired. If faulty or damaged, the entire unit must be replaced. The control knobs and the illumination lamps are available for service replacement.

HEATER AND AIR CONDITIONING

All vehicles are equipped with a common heater-A/C housing assembly (Fig. 1). The system combines air conditioning, heating, and ventilating capabilities in a single unit housing mounted under the instrument panel. On heater-only systems, the evaporator coil is omitted from the housing and replaced with an air restrictor plate.

Outside air enters the vehicle through the cowl top opening at the base of the windshield, and passes through a plenum chamber to the heater-A/C system blower housing. Air flow velocity can then be adjusted with the blower motor speed selector switch on the heater-A/C control panel. The air intake openings must be kept free of snow, ice, leaves, and other obstructions for the heater-A/C system to receive a sufficient volume of outside air.

GENERAL INFORMATION (Continued)

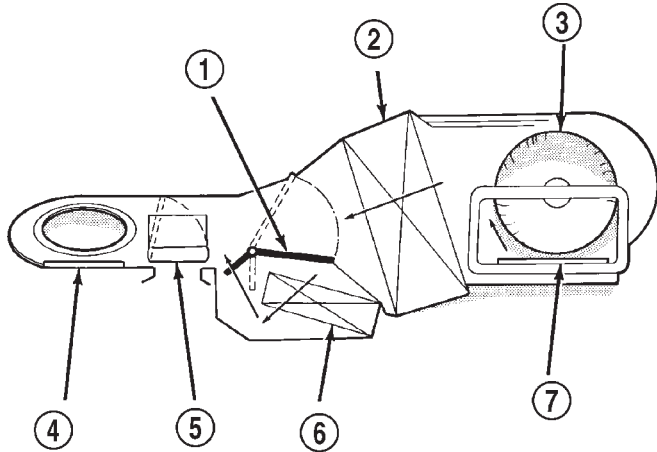

J9324-3

Fig. 1 Common Blend-Air HVAC (Heating, Ventilation, Air Conditioning) System - Typical

- 1 - TEMPERATURE BLEND/AIR DOOR
- 2 - EVAPORATOR CORE
- 3 - BLOWER
- 4 - PANEL DEFROST DOOR
- 5 - HEAT DEFROST DOOR
- 6 - HEATER CORE
- 7 - RECIRCULATING AIR DOOR

It is also important to keep the air intake openings clear of debris because leaf particles and other debris that is small enough to pass through the cowl plenum screen can accumulate within the heater-A/C housing. The closed, warm, damp and dark environment created within the heater-A/C housing is ideal for the growth of certain molds, mildews and other fungi. Any accumulation of decaying plant matter provides an additional food source for fungal spores, which enter the housing with the fresh air. Excess debris, as well as objectionable odors created by decaying plant matter and growing fungi can be discharged into the passenger compartment during heater-A/C system operation.

The heater and optional air conditioner are blend-air type systems. In a blend-air system, a blend-air door controls the amount of unconditioned air (or cooled air from the evaporator on models with air conditioning) that is allowed to flow through, or around, the heater core. A temperature control knob on the heater-A/C control panel determines the discharge air temperature by moving a cable, which operates the blend-air door. This allows an almost immediate manual control of the output air temperature of the system.

The mode control knob on the heater-only or heater-A/C control panel is used to direct the conditioned air to the selected system outlets. The mode control switch uses a cable to control the mode door, while the recirculation air door is operated by a vacuum actuator motor.

On air conditioned vehicles, the outside air intake can be shut off by selecting the recirculation mode (Recirc) with the mode control knob. This will operate a vacuum actuated recirculating air door that closes off the outside fresh air intake and recirculates the air that is already inside the vehicle.

The optional air conditioner for all models is designed for the use of non-CFC, R-134a refrigerant. The air conditioning system has an evaporator to cool and dehumidify the incoming air prior to blending it with the heated air. This air conditioning system uses an evaporator probe to maintain minimum evaporator temperature and prevent evaporator freezing, and cycles the compressor clutch.

INTRODUCTION

Both the heater and the heater/air conditioning systems share many of the same functioning components. This group will deal with both systems together when component function is common, and separately when they are not.

For proper operation of the instrument panel controls, refer to the Owner's Manual provided with the vehicle.

To service the heater core or evaporator, the unit housing must be removed from the vehicle (Fig. 2).

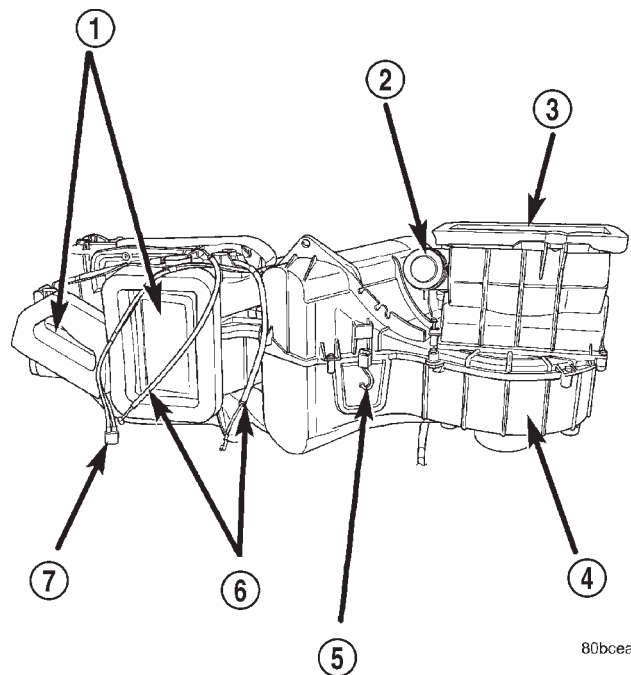

80bcea25

Fig. 2 HVAC Unit Housing

- 1 - AIR DISTRIBUTION
- 2 - RECIRCULATION DOOR VACUUM ACTUATOR
- 3 - AIR INLET
- 4 - BLOWER MOTOR
- 5 - EVAPORATOR PROBE CONNECTOR
- 6 - CONTROL CABLES
- 7 - VACUUM HARNESS

GENERAL INFORMATION (Continued)

SAFETY PRECAUTIONS AND WARNINGS

WARNING: WEAR EYE PROTECTION WHEN SERVICING THE AIR CONDITIONING REFRIGERANT SYSTEM. SERIOUS EYE INJURY CAN RESULT FROM EYE CONTACT WITH REFRIGERANT. IF EYE CONTACT IS MADE, SEEK MEDICAL ATTENTION IMMEDIATELY.

DO NOT EXPOSE REFRIGERANT TO OPEN FLAME. POISONOUS GAS IS CREATED WHEN REFRIGERANT IS BURNED. AN ELECTRONIC TYPE LEAK DETECTOR IS RECOMMENDED.

LARGE AMOUNTS OF REFRIGERANT RELEASED IN A CLOSED WORK AREA WILL DISPLACE THE OXYGEN AND CAUSE SUFFOCATION.

THE EVAPORATION RATE OF REFRIGERANT AT AVERAGE TEMPERATURE AND ALTITUDE IS EXTREMELY HIGH. AS A RESULT, ANYTHING THAT COMES IN CONTACT WITH THE REFRIGERANT WILL FREEZE. ALWAYS PROTECT SKIN OR DELICATE OBJECTS FROM DIRECT CONTACT WITH REFRIGERANT. R-134a SERVICE EQUIPMENT OR VEHICLE A/C SYSTEM SHOULD NOT BE PRESSURE TESTED OR LEAK TESTED WITH COMPRESSED AIR.

SOME MIXTURES OF AIR and R-134a HAVE BEEN SHOWN TO BE COMBUSTIBLE AT ELEVATED PRESSURES. THESE MIXTURES ARE POTENTIALLY DANGEROUS AND MAY RESULT IN FIRE OR EXPLOSION CAUSING INJURY OR PROPERTY DAMAGE.

ANTIFREEZE IS AN ETHYLENE GLYCOL BASE COOLANT AND IS HARMFUL IF SWALLOWED OR INHALED. SEEK MEDICAL ATTENTION IMMEDIATELY IF SWALLOWED OR INHALED. DO NOT STORE IN OPEN OR UNMARKED CONTAINERS. WASH SKIN AND CLOTHING THOROUGHLY AFTER COMING IN CONTACT WITH ETHYLENE GLYCOL. KEEP OUT OF REACH OF CHILDREN AND PETS.

DO NOT OPEN A COOLING SYSTEM WHEN THE ENGINE IS AT RUNNING TEMPERATURE. PERSONAL INJURY CAN RESULT.

CAUTION: The engine cooling system is designed to develop internal pressure of 97 to 123 kPa (14 to 18 psi). Allow the vehicle to cool a minimum of 15 minutes before opening the cooling system. Refer to Group 7, Cooling System.

DESCRIPTION AND OPERATION

A/C REFRIGERANT LINES

DISCHARGE LINE

The discharge line is the line that goes from the compressor to the condenser (Fig. 3). It has no serviceable parts except the rubber O-rings. If the line is found to be leaking or is damaged it must be replaced as an assembly.

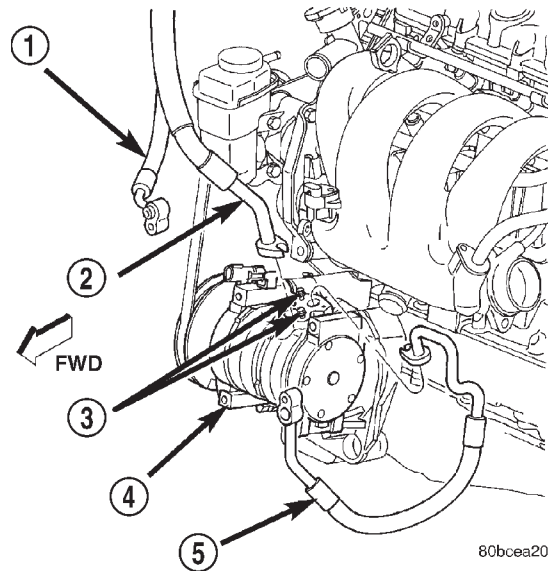

Fig. 3 A/C Compressor Lines

- 1 - CONDENSER LIQUID LINE
- 2 - SUCTION LINE
- 3 - COMPRESSOR MANIFOLD SCREWS
- 4 - COMPRESSOR
- 5 - DISCHARGE LINE

LIQUID LINE

The liquid line is the line that goes from the condenser to drier (Fig. 3). It has no serviceable parts except the rubber O-rings. If the line is found to be leaking or is damaged it must be replaced as an assembly.

SUCTION LINE

The suction line is the large line that connects to the expansion valve and goes to the compressor (Fig. 3). It also has a small line that goes to the filter/drier. The suction line uses a gasket on the expansion valve side and rubber O-rings on all other connections.

There are no serviceable parts on the suction line other than the rubber O-rings and expansion valve gasket. If the line is found to be leaking or is damaged it must be replaced as an assembly.

DESCRIPTION AND OPERATION (Continued)

A/C SERVICE PORT VALVE CORES

The A/C service port valve cores are serviceable items (Fig. 4). The high side valve is located on the filter-drier, and the low side valve is situated on the suction line, near the washer fluid reservoir filler.

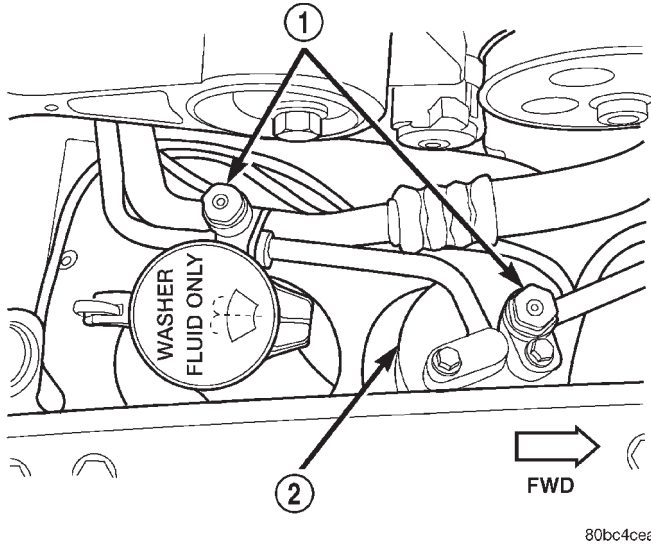

Fig. 4 A/C Service Port Valves

- 1 - A/C SERVICE PORTS
- 2 - FILTER/DRIER

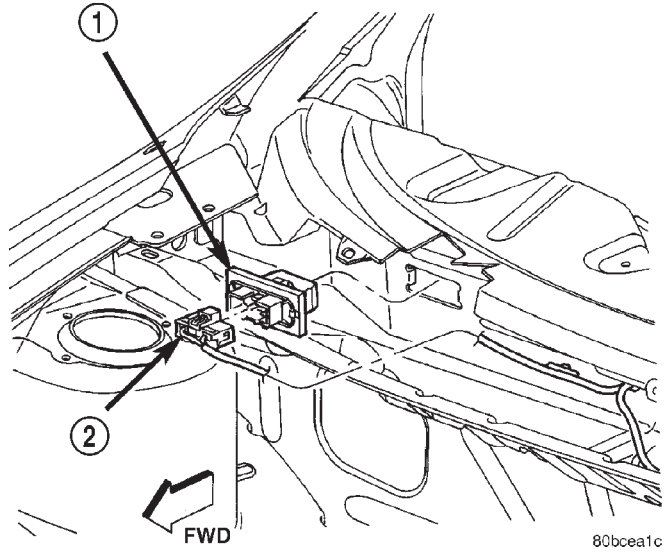

Fig. 5 Blower Motor Resistor Block

- 1 - RESISTOR BLOCK
- 2 - ELECTRICAL CONNECTOR

BLOWER MOTOR RESISTOR

The blower motor resistor is located in the cowl, at the base of the windshield (Fig. 5). There are two different resistor blocks depending on whether the vehicle is equipped with A/C or not. The blower motor resistors will get hot when in use (Fig. 6). Do not touch resistor block if the blower motor has been running.

COMPRESSOR

The compressor used on this vehicle is a Nippondenso 10S17. This compressor uses an aluminum swash plate, teflon coated pistons and aluminum sleeveless cylinder walls.

NOISE

Excessive noise that occurs when the air conditioning is being used may be caused by:

- Loose bolts
- Mounting brackets
- Loose compressor clutch
- Excessive high refrigerant operating pressure

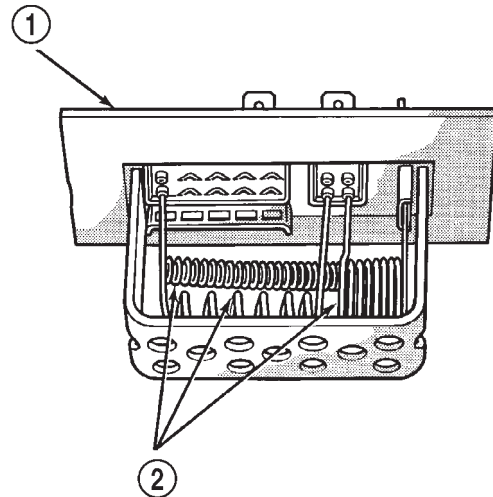

Fig. 6 Blower Motor Resistors

- 1 - RESISTOR BLOCK
- 2 - RESISTORS

Verify the following before compressor repair is performed:

- (1) Compressor drive belt condition
- (2) Proper refrigerant charge
- (3) Thermal expansion valve (TXV) operating correctly
- (4) Head pressure is normal

DESCRIPTION AND OPERATION (Continued)

COMPRESSOR FRONT SHAFT SEAL

The compressor front shaft seal is not serviceable. If a leak is detected at the shaft seal, the compressor must be replaced as a unit.

CONDENSATION DRAIN TUBE

Condensation that accumulates in the evaporator housing is drained from a tube through the dash and on to the ground. This tube must be kept open to prevent condensate water from collecting in the bottom of the housing.

The tapered end of the drain tube is designed to keep contaminants from entering the heater A/C unit housing. If the tube is pinched or blocked, condensate cannot drain, causing water to back up and spill into the passenger compartment. It is normal to see condensate drainage below the vehicle. If the tube is damaged, it should be replaced.

ENGINE COOLING SYSTEM REQUIREMENTS

To maintain ample temperature levels from the heating-A/C system, the cooling system must be in proper working order. Refer to Group 0, Lubrication and Maintenance or Group 7, Cooling System of this manual.

The use of a bug screen is not recommended. Any obstructions forward of the condenser can reduce the effectiveness of the air conditioning system.

EVAPORATOR PROBE

The evaporator probe can be replaced without having to remove the unit housing from the vehicle.

The evaporator probe is located in the unit housing and placed in the evaporator fins. The probe prevents evaporator freeze-up. This is done by cycling the compressor clutch OFF when evaporator temperature drops below freeze point. It cycles ON when the evaporator temperature rises above freeze point. The evaporator probe uses a thermistor probe in a capillary tube. The tube is inserted between the evaporator fins in the heater-A/C unit housing.

HANDLING TUBING AND FITTINGS

Kinks in the refrigerant tubing or sharp bends in the refrigerant hose lines will greatly reduce the capacity of the entire system. High pressures are produced in the system when it is operating. Extreme care must be exercised to make sure that all connections are pressure tight. Dirt and moisture can enter the system when it is opened for repair or replacement of lines or components. The refrigerant oil will absorb moisture readily out of the air. This moisture will convert into acids within a closed system.

CAUTION: The system must be completely empty before opening any fitting or connection in the refrigeration system. Open fittings with caution even after the system has been emptied. If any pressure is noticed as a fitting is loosened, retighten fitting and evacuate the system again.

A good rule for the flexible hose lines is to keep the radius of all bends at least 10 times the diameter of the hose. Sharper bends will reduce the flow of refrigerant. The flexible hose lines should be routed so they are at least 3 inches (80 mm) from the exhaust manifold. Inspect all flexible hose lines to make sure they are in good condition and properly routed.

The use of correct wrenches when making connections is very important. Improper wrenches or improper use of wrenches can damage the fittings.

The internal parts of the A/C system will remain stable as long as moisture-free refrigerant and refrigerant oil is used. Abnormal amounts of dirt, moisture or air can upset the chemical stability. This may cause operational troubles or even serious damage if present in more than very small quantities.

When opening a refrigeration system, have everything you will need to repair the system ready. This will minimize the amount of time the system must be opened. Cap or plug all lines and fittings as soon as they are opened. This will help prevent the entrance of dirt and moisture. All new lines and components should be capped or sealed until they are ready to be used.

All tools, including the refrigerant dispensing manifold, the manifold gauge set, and test hoses should be kept clean and dry.

HIGH PRESSURE CUT OUT SWITCH

The high pressure cut out switch is located on the rear of the compressor (Fig. 7). It turns off the compressor if the system pressure exceeds 3240 kPa (470 psi).

LOW PRESSURE CUT OFF SWITCH

The Low Pressure Cut Off Switch (Fig. 8) monitors the refrigerant gas pressure on the suction side of the system. The low pressure cut off switch is located on the expansion valve. The low pressure cut off switch turns off voltage to the compressor clutch coil when refrigerant gas pressure drops to levels that could damage the compressor. The low pressure cut out switch is a sealed factory calibrated unit. It must be replaced if defective.

DESCRIPTION AND OPERATION (Continued)

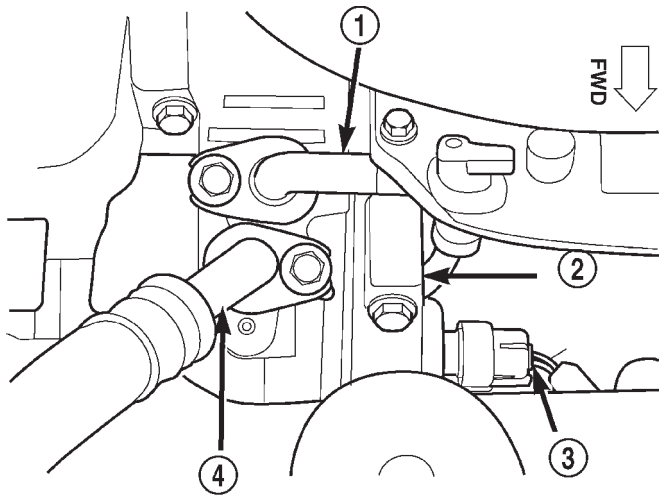

80bcea29

Fig. 7 High Pressure Cut Out Switch Location

- 1 - DISCHARGE LINE
- 2 - A/C COMPRESSOR
- 3 - HIGH PRESSURE CUT OUT SWITCH
- 4 - SUCTION LINE

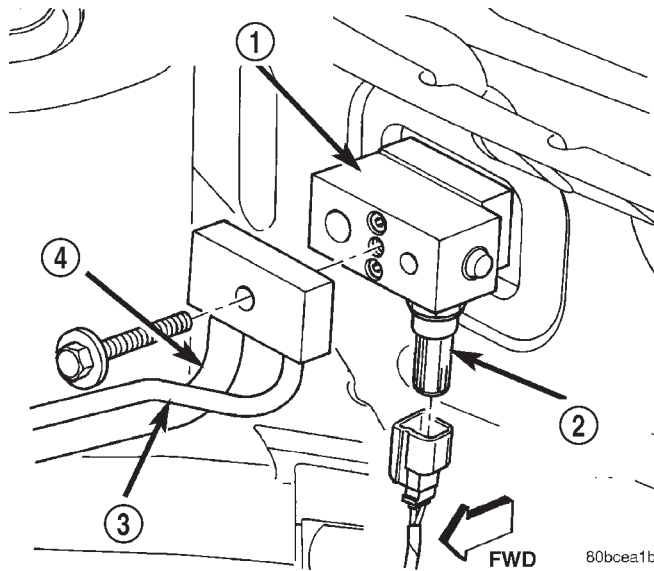

80bcea1b

Fig. 8 Low Pressure Cut Off Switch

- 1 - EXPANSION VALVE
- 2 - LOW PRESSURE CUTOFF SWITCH
- 3 - LIQUID LINE
- 4 - SUCTION LINE

SIDE WINDOW DEMISTERS

The demisters direct air from the unit housing through the outlets located on the top corners of the instrument panel. The demisters operate when the mode selector is anywhere between floor and defrost settings. Some air may be noticeable from the demister outlets when the mode selector is in the bilevel to floor positions.

SYSTEM AIRFLOW

The system pulls outside (ambient) air through the cowl opening at the base of the windshield. Then it goes into the plenum chamber above the unit housing. On air conditioned vehicles, the air passes through the evaporator. Air flow can be directed either through or around the heater core. This is done by adjusting the blend-air door with the TEMP control on the instrument panel. The air flow can then be directed from the panel, floor and defrost outlets in various combinations using the mode selector. There are 17 different mode selections possible. Air flow velocity can be adjusted with the blower speed selector switch on the instrument panel.

On A/C equipped vehicles the ambient air intake can be controlled by opening and closing the recirculating air door. When placed in RECIRC, air that is inside vehicle is removed continuously and recirculated through unit housing. Ambient air cannot be controlled on vehicles without A/C. The system uses outside air at all times.

The air conditioning compressor can be engaged by turning the fan switch counterclockwise from the off position. It can also be engaged by placing the mode control in the mix to defrost positions. This will remove heat and humidity from the air before it is directed through or around the heater core.

SYSTEM OIL LEVEL

It is important to have the correct amount of oil in the A/C system to ensure proper lubrication of the compressor. Too little oil will result in damage to the compressor. Too much oil will reduce the cooling capacity of the system and consequently result in higher discharge air temperatures.

DESCRIPTION AND OPERATION (Continued)

NOTE: The oil used in the compressor is ND8 PAG R-134a refrigerant oil. Only refrigerant oil of the same type should be used to service the system. Do not use any other oil. The oil container should be kept tightly capped until it is ready for use. Tightly cap afterwards to prevent contamination from dirt and moisture. Refrigerant oil will quickly absorb any moisture it comes in contact with. Special effort must be used to keep all R-134a system components moisture-free. Moisture in the oil is very difficult to remove and will cause a reliability problem with the compressor.

It will not be necessary to check oil level in the compressor or to add oil unless there has been an oil loss. Oil loss at a leak point will be evident by the presence of a wet, shiny surface around the leak.

REFRIGERANT OIL LEVEL CHECK

When an air conditioning system is first assembled, all components (except the compressor) are refrigerant oil free. After the system has been charged with R-134a refrigerant and operated, the oil in the compressor is dispersed through the lines and components. The evaporator, condenser, and filter-drier will retain a significant amount of oil, refer to the Refrigerant Oil Capacities chart. When a component is replaced, the specified amount of refrigerant oil must be added. When the compressor is replaced, the amount of oil that is retained in the rest of the system must be drained from the replacement compressor. When a line or component has ruptured and oil has escaped, the compressor should be removed and drained. The filter-drier must be replaced along with the ruptured part. The oil capacity of the system, minus the amount of oil still in the remaining components, can be measured and poured into the suction port of the compressor.

REFRIGERANT OIL CAPACITIES

Refrigerant Oil Capacities		
Component	ml	oz
Total System	180ml	6.1 oz
Filter-Drier	30 ml	1.0 oz
Condenser	30 ml	1.0 oz
Evaporator	59 ml	2.0 oz
All Refrigerant Lines	44 ml	1.5 oz

VACUUM CONTROL SYSTEM

The neon uses vacuum to operate only the recirculation door (Fig. 9). All other controls are cable. When vacuum is supplied to the actuator, the door moves to the Recirculation position (Fig. 10). The

actuator is spring loaded so the door moves to the Outside-air position when there is no vacuum supplied. The operation of the door can be viewed by removing the blower motor and looking up into the unit inlet.

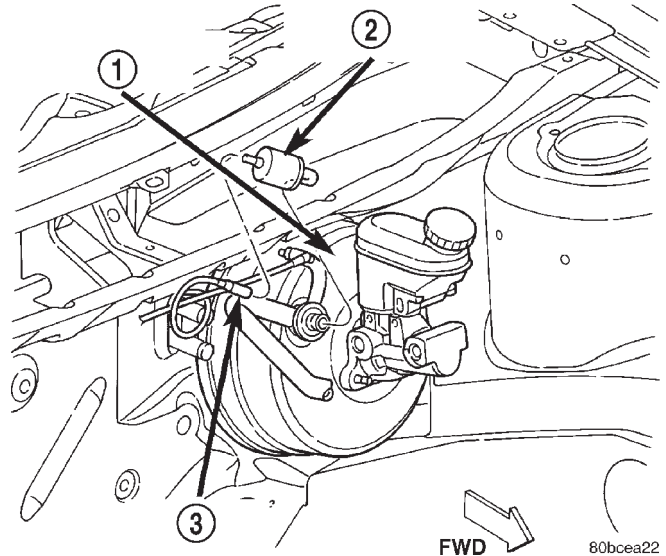

Fig. 9 A/C Vacuum Line

- 1 - BRAKE POWER BOOSTER
- 2 - A/C VACUUM CHECK VALVE
- 3 - VACUUM HARNESS

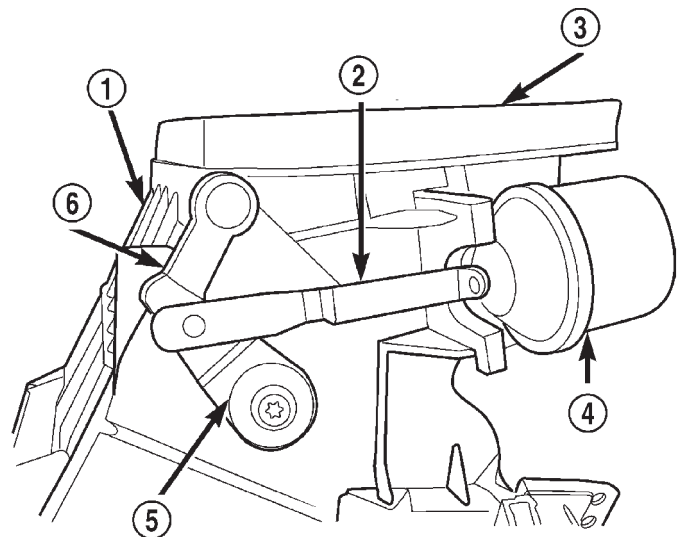

Fig. 10 Recirculation Air Door Vacuum Actuator

- 1 - OUTSIDE AIR/RECIRC DOOR HOUSING
- 2 - VACUUM ACTUATOR LINKAGE
- 3 - FOAM SEAL
- 4 - RECIRC DOOR VACUUM ACTUATOR
- 5 - DOOR LEVER
- 6 - DOOR LEVER

DESCRIPTION AND OPERATION (Continued)

Normally, vacuum is supplied to the actuator by placing the Circulation control knob in the Recirculation position. The Mode and the circulation control are mechanically interlocked so the circulation control cannot be placed in the RECIRC position if the mode control is at or between the mix and defrost positions. Vacuum is supplied to the actuator only when circulation control is at the RECIRC position. If the circulation control is between the outside air position and RECIRC position the system will be in outside air. If the circulation control is in the RECIRC position and the mode control is moved from the floor to the defrost positions, the circulation control will move from the RECIRC position, to the outside air position beginning at the mix position. This is to prevent window fogging.

DIAGNOSIS AND TESTING

A/C PERFORMANCE TEST

The air conditioning system is designed to remove heat and humidity from the air entering the passenger compartment. The evaporator, located in the heater A/C unit, is cooled to temperatures near the freezing point. As warm damp air passes over the fins in the evaporator, moisture in the air condenses to water, dehumidifying the air. Condensation on the evaporator fins reduces the evaporators ability to absorb heat. During periods of high heat and humidity, an air conditioning system will be less effective. With the instrument control set to RECIRC, only air from the passenger compartment passes through the

evaporator. As the passenger compartment air dehumidifies, A/C performance levels rise.

PERFORMANCE TEST PROCEDURE

Review Safety Precautions and Warnings in this group before proceeding with this procedure. Air temperature in test room and on vehicle must be 21° C (70°F) minimum for this test.

NOTE: When connecting the service equipment coupling to the line fitting, verify that the valve of the coupling is fully closed. This will reduce the amount of effort required to make the connection.

- (1) Connect a tachometer and manifold gauge set.
- (2) Set control to A/C, RECIRC, and PANEL, temperature lever on full cool and blower on high.
- (3) Start engine and hold at 1000 rpm with A/C clutch engaged.
- (4) Engine should be warmed up with doors and windows closed.
- (5) Insert a thermometer in the left center A/C outlet and operate the engine for five minutes. The A/C clutch may cycle depending on ambient conditions.
- (6) With the A/C clutch engaged, compare the discharge air temperature to the A/C Performance Temperatures chart.
- (7) If the discharge air temperature fails to meet the specifications in the performance temperature chart. Refer to the Refrigerant Service Procedures for further diagnosis.

A/C PERFORMANCE TEMPERATURES

Ambient Temperature	21°C (70°F)	26.5°C (80°F)	32°C (90°F)	37°C (100°F)	43°C (110°F)
Air Temperature at Left Center Panel Outlet	1-8°C (34-46°F)	3-9°C (37-49°F)	4-10°C (39-50°F)	6-11°C (43-52°F)	7-18°C (45-65°F)
Compressor Discharge Pressure After the Filter Drier	1034-1724 kPa (150-250 PSI)	1517-2275 kPa (220-330 PSI)	1999-2620 kPa (290-380 PSI)	2068-2965 kPa (300-430 PSI)	2275-3421 kPa (330-496 PSI)
Evaporator Suction Pressure	103-207 kPa (15-30 PSI)	117-221 kPa (17-32 PSI)	138-241 kpa (20-35 PSI)	172-269 kpa (25-39 PSI)	207-345 kPa (30-50 PSI)

BLOWER MOTOR ELECTRICAL DIAGNOSIS

Refer to the Blower Motor Electrical System Diagnosis chart (Fig. 11) in this section. Also refer to Group 8W, Wiring Diagrams for more information.

DIAGNOSIS AND TESTING (Continued)

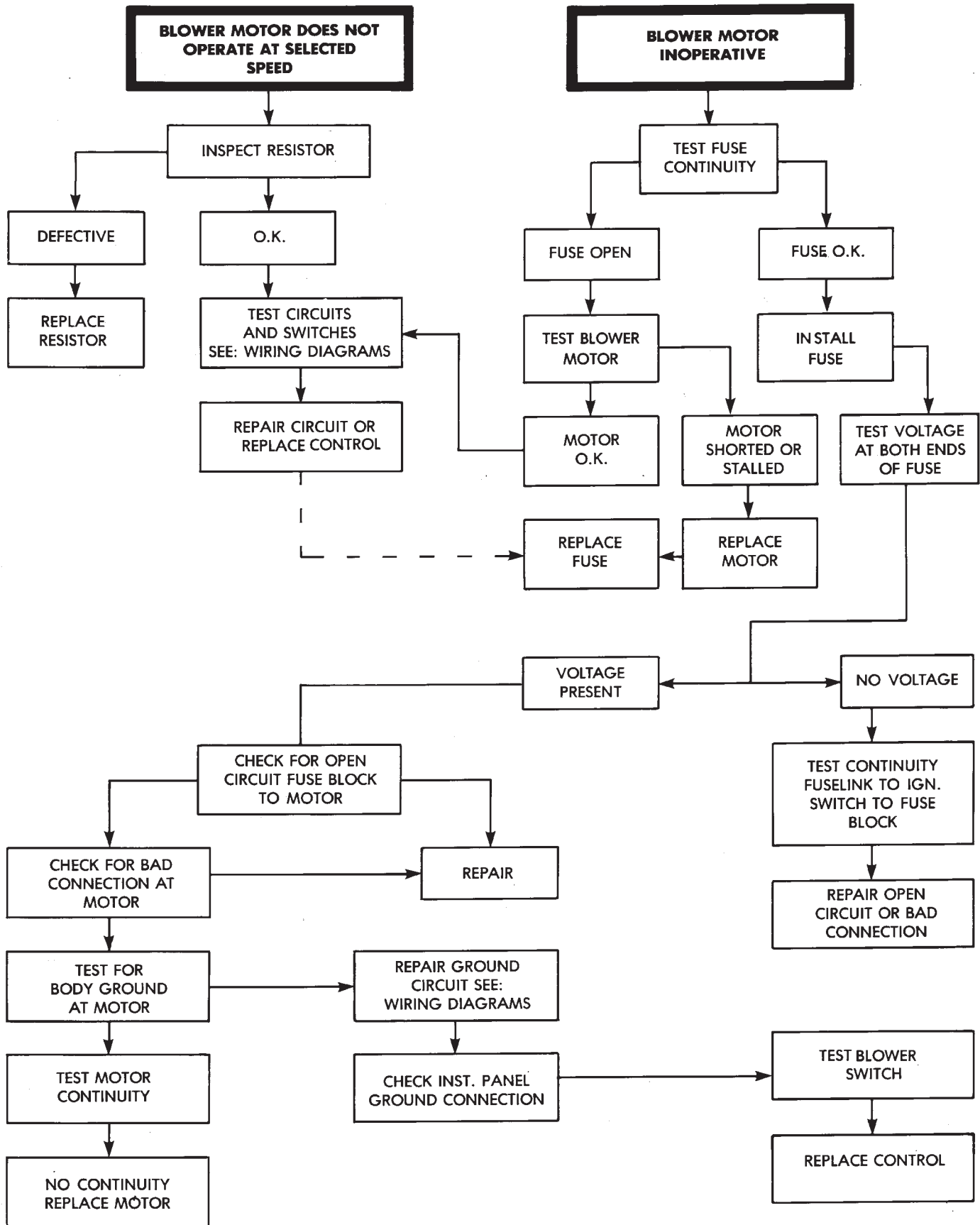

9524-4

Fig. 11 Blower Motor Electrical Diagnosis

DIAGNOSIS AND TESTING (Continued)

BLOWER MOTOR VIBRATION AND/OR NOISE DIAGNOSIS

The resistor block supplies the blower motor with varied voltage (low and middle speeds) or battery voltage (high speed).

CAUTION: Stay clear of the blower motor and resistor block (Hot). Do not operate the blower motor with the resistor block removed from the heater-A/C housing.

Refer to the Blower Motor Vibration/Noise chart for diagnosis.

COMPRESSOR NOISE DIAGNOSIS

Excessive noise while the A/C is being used, can be caused by loose mounts, loose clutch, or high operating pressure. Verify compressor drive belt condition, proper refrigerant charge and head pressure before compressor repair is performed.

If the A/C drive belt slips at initial start-up, it does not necessarily mean the compressor has failed.

With the close tolerances of a compressor it is possible to experience a temporary lockup. The longer the A/C system is inactive, the more likely the condition to occur.

This condition is the result of normal refrigerant movement within the A/C system caused by temperature changes. The refrigerant movement may wash the oil out of the compressor.

EVAPORATOR PROBE TEST

The work area and vehicle must be between 16° C (60° F) and 32° C (90° F) when testing the switch.

(1) Disconnect the three wire connector from the evaporator probe lead located behind the glove box (Fig. 12).

(2) Start engine and set A/C to low blower motor speed, panel, full cool, and RECIRC.

(3) Using a voltmeter, check for battery voltage between Pin 1 and 2. If no voltage is detected, there is no power to the switch. Check wiring and fuses. Refer to Group 8W, Wiring Diagrams for circuit diagnosis.

(4) Using a voltmeter, check for battery voltage between Pin 1 and Pin 3. If no voltage is detected, there is no voltage from the Powertrain Control Module. Refer to Group 8W, Wiring Diagrams. If voltage is OK, connect a jumper wire between Pin 1 and Pin 3. The compressor clutch should engage. If the clutch engages, remove the jumper wire immediately and go to Step 5. If the compressor clutch does not engage, check the operation of the clutch and repair as necessary.

(5) If compressor clutch engages, connect the evaporator probe 3-way connector. The compressor clutch should engage or cycle depending on evaporator temperature. If OK, go to Step 6. If not OK, replace the clutch cycling switch.

(6) The engine running and the A/C set to:

- Blower motor on low speed
- Panel position
- Full cool
- RECIRC.

Close all doors and windows. Place a thermometer in the center discharge vent.

(7) If the clutch does not begin to cycle off between 2° C to 7° C (35° F to 45° F), verify that the evaporator probe is fully installed and not loose in evaporator. If it is not properly installed, install probe and retest outlet temperature. If the evaporator probe is properly installed, replace the clutch cycling switch.

EXPANSION VALVE

NOTE: Expansion valve tests should be performed after compressor tests.

Liquid CO₂ is required to test the expansion valve. It is available from most welding supply facilities. CO₂ is also available from companies which service and sell fire extinguishers.

Review Safety Precautions and Warnings in the General Information section of this Group. The work area and vehicle must be 21° to 27° C (70° to 85° F) when testing expansion valve. To test the expansion valve:

(1) Connect a charging station or manifold gauge set to the refrigerant system service ports.

(2) Disconnect wire connector at low pressure cut-off switch (Fig. 13). Using a jumper wire, jump terminals inside wire connector boot.

(3) Close all doors, windows and vents to the passenger compartment.

(4) Set Heater-A/C control to A/C, full heat, floor, RECIRC. and high blower.

(5) Start the engine and hold the idle speed (1000 rpm). After the engine has reached running temperature, allow the passenger compartment to heat up. This will create the need for maximum refrigerant flow into the evaporator.

(6) If the refrigerant charge is sufficient, discharge (high pressure) gauge should read 965 to 2620 kPa (140 to 380 psi). Suction (low pressure) gauge should read 103 to 2417 kPa (15 to 35 psi). If system cannot achieve proper pressure readings, replace the expansion valve. If pressure is correct, proceed with test.

DIAGNOSIS AND TESTING (Continued)

BLOWER MOTOR NOISE/VIBRATION DIAGNOSIS

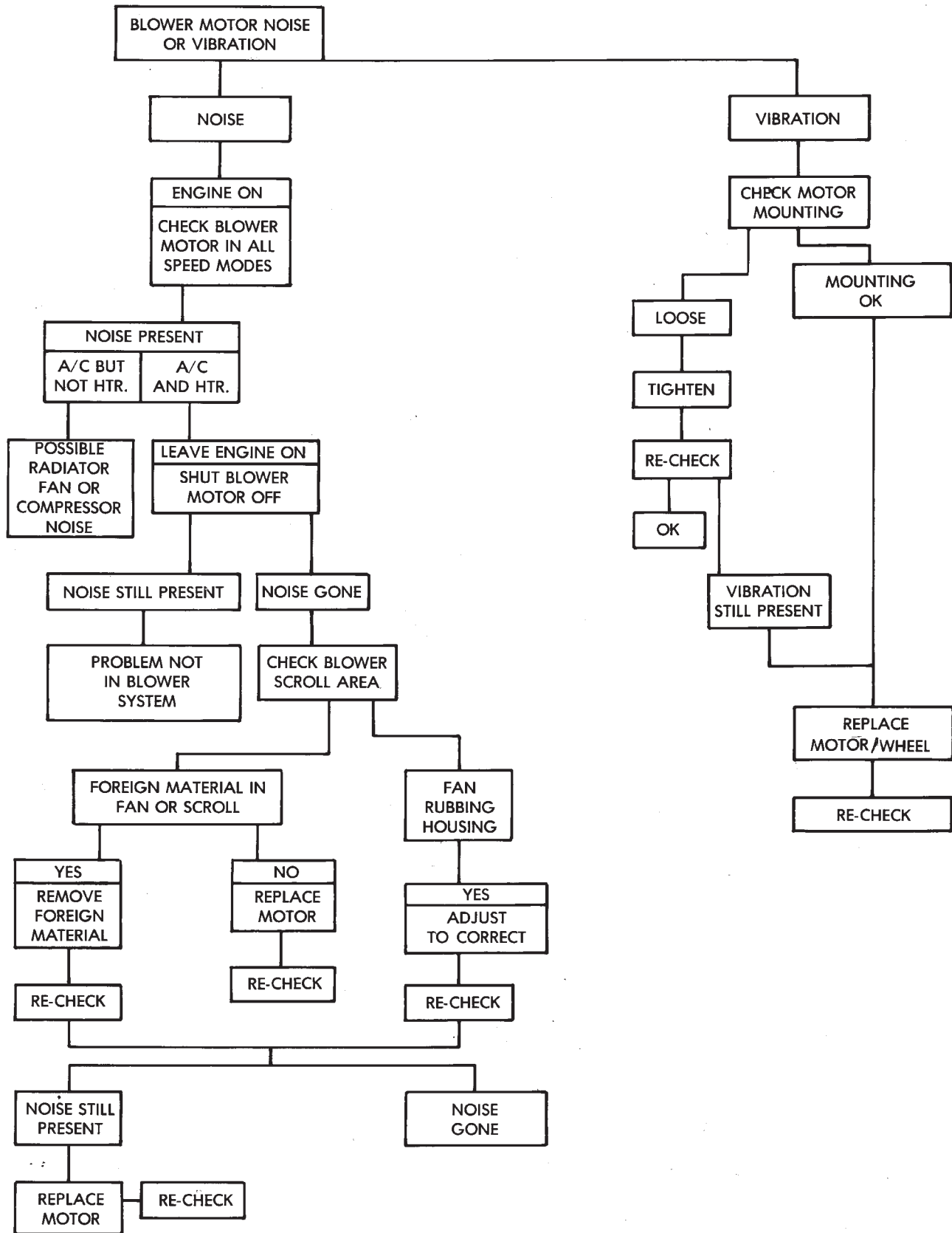

DIAGNOSIS AND TESTING (Continued)

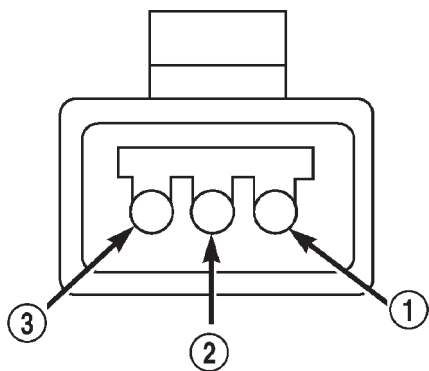

80a7e366

Fig. 12 Evaporator Probe Harness Connector

- 1 - PIN #3
- 2 - PIN #2
- 3 - PIN #1

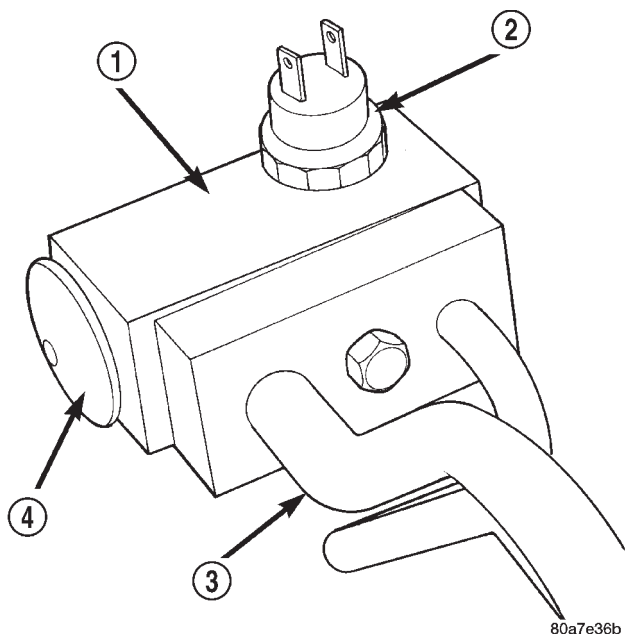

80a7e36b

Fig. 13 Expansion Valve & Low Pressure Cut-Off Switch - Typical

- 1 - EXPANSION VALVE
- 2 - LOW PRESSURE CUT OFF SWITCH
- 3 - SUCTION LINE
- 4 - CONTROL HEAD

WARNING: PROTECT SKIN AND EYES FROM CONTACTING CO2 PERSONAL INJURY CAN RESULT.

(7) If suction side low pressure is within specified range, freeze the expansion valve control head (Fig. 13) for 30 seconds. Use a super cold substance (liquid CO₂). **Do not spray refrigerant on the expansion valve for this test.** Suction side low pressure should drop to 34.5 kPa (5 psi) If not, replace expansion valve.

(8) Allow expansion valve to thaw. The low pressure gauge reading should stabilize at 103 to 241 kPa (15 to 35 psi). If not, replace expansion valve.

(9) When expansion valve test is complete, test A/C overall performance. Refer to the Heater and A/C Performance Test in this section. Remove all test equipment before returning vehicle to use.

HEATER PERFORMANCE TEST

PRE-DIAGNOSTIC PREPARATIONS

Review Safety Precautions and Warnings in this group before performing the following procedures.

Check the coolant level, drive belt tension, vacuum line connections, radiator air flow and fan operation. Start engine and allow to warm up to normal temperature.

WARNING: DO NOT REMOVE RADIATOR CAP WHEN ENGINE IS HOT, PERSONAL INJURY CAN RESULT.

If vehicle has been run recently, wait 15 minutes before removing cap. Place a rag over the cap and turn it to the first safety stop. Allow pressure to escape through the overflow tube. When the system stabilizes, remove the cap completely.

MAXIMUM HEATER OUTPUT: TEST AND ACTION

Engine coolant is provided to the heater system by two 16 mm (5/8 inch inside diameter) heater hoses. With engine idling at normal running temperature, set the control to maximum heat, floor, and high blower setting. Using a test thermometer, check the air temperature coming from the floor outlets, refer to Temperature Reference chart.

TEMPERATURE REFERENCE CHART

Ambient Temp.		Minimum Outlet Floor Temp.	
Celsius	Fahrenheit	Celsius	Fahrenheit
15.5°	60°	62.2°	144°
21.1°	70°	63.8°	147°
26.6°	80°	65.5°	150°
32.2°	90°	67.2°	153°

If the floor outlet air temperature is insufficient, refer to Group 7, Cooling Systems for specifications. Both heater hoses should be HOT to the touch (coolant return hose should be slightly cooler than the supply hose). If coolant return hose is much cooler than the supply hose, locate and repair engine coolant flow obstruction in heater system.

DIAGNOSIS AND TESTING (Continued)

POSSIBLE LOCATIONS OR CAUSE OF OBSTRUCTED COOLANT FLOW

- (1) Pinched or kinked heater hoses.
- (2) Improper heater hose routing.
- (3) Plugged heater hoses or supply and return ports at cooling system connections, refer to Group 7, Cooling System.
- (4) Plugged heater core.
- (5) Air locked heater core.
- (6) If coolant flow is verified and outlet temperature is insufficient, a mechanical problem may exist.

POSSIBLE LOCATION OR CAUSE OF INSUFFICIENT HEAT

- (1) Obstructed cowl air intake.
- (2) Obstructed heater system outlets.
- (3) Blend-air door not functioning properly.

TEMPERATURE CONTROL

If temperature cannot be adjusted with the TEMP lever on the control panel, the following could require service:

- (1) Blend-air door binding.
- (2) Faulty blend-air door cable.
- (3) Improper engine coolant temperature.
- (4) Faulty Instrument Panel Control.

LOW PRESSURE CUT OFF SWITCH

The work area must not be below 21°C (70°F) to test the compressor clutch circuit.

- (1) With gear selector in park or neutral and park brake set, start engine and allow to idle.
- (2) Raise hood and disconnect low pressure cut off switch connector boot.
- (3) Using a suitable jumper wire, jump across the terminals inside wire connector boot.
- (4) If the compressor clutch does not engage, the cycling clutch switch, wiring, relay, or fuse can be defective. Refer to Group 8W, Wiring Diagrams.
- (5) If clutch engages, connect manifold gauge set. Read low pressure gauge. At pressure above 97 kPa (14 psi) and above, low pressure cut off switch will complete the clutch circuit. If the low pressure gauge reads below 140 kPa (20 psi), the system is low on refrigerant charge or empty due to a leak. Refer to Service Procedures, System Leak Checking in this section.
- (6) Install connector boot on switch and repeat Step 3. If the clutch does not engage, replace the low pressure cut off switch.

SYSTEM CHARGE LEVEL TEST

The procedure below should be used to check and/or fill the refrigerant charge in the air conditioning system.

WARNING: AVOID BREATHING A/C REFRIGERANT AND LUBRICANT VAPOR OR MIST. EXPOSURE MAY IRRITATE EYES, NOSE AND THROAT. USE ONLY APPROVED SERVICE EQUIPMENT MEETING SAE REQUIREMENTS TO DISCHARGE R-134a SYSTEM. IF ACCIDENTAL SYSTEM DISCHARGE OCCURS, VENTILATE WORK AREA BEFORE RESUMING SERVICE.

R-134a SERVICE EQUIPMENT OR VEHICLE A/C SYSTEM SHOULD NOT BE PRESSURE TESTED OR LEAK TESTED WITH COMPRESSED AIR. MIXTURE OF AIR and R-134a CAN BE COMBUSTIBLE AT ELEVATED PRESSURES. THESE MIXTURES ARE POTENTIALLY DANGEROUS AND MAY RESULT IN FIRE OR EXPLOSION CAUSING INJURY OR PROPERTY DAMAGE.

NOTE: The maximum amount of R-134a refrigerant that the air conditioning system holds is 765 grams (27 oz. or 1.69 lbs.)

It is recommended to use the gauges or reclaim/recycle equipment.

- (1) Use a manifold gauge and check the liquid line pressure.
- (2) Attach a clamp-on thermocouple (P. S. E. 66-324-0014 or 80PK-1A) or equivalent to the liquid line near the filter/drier.
- (3) The vehicle must be in the following modes:
 - Automatic transaxle in park or manual transaxle in neutral.
 - Engine at idle
 - A/C controls set to outside air
 - Panel mode
 - A/C ON full cool
 - Blower motor ON high speed
 - Vehicle windows closed
- (4) Operate system for a couple of minutes to allow the system to stabilize.
- (5) Observe filter/drier pressure and Liquid line temperature. Using the Charge Determination Chart (Fig. 14) determine where the system is currently operating. If the system is not in the proper range, reclaim all the refrigerant and recharge per A/C label.

DIAGNOSIS AND TESTING (Continued)

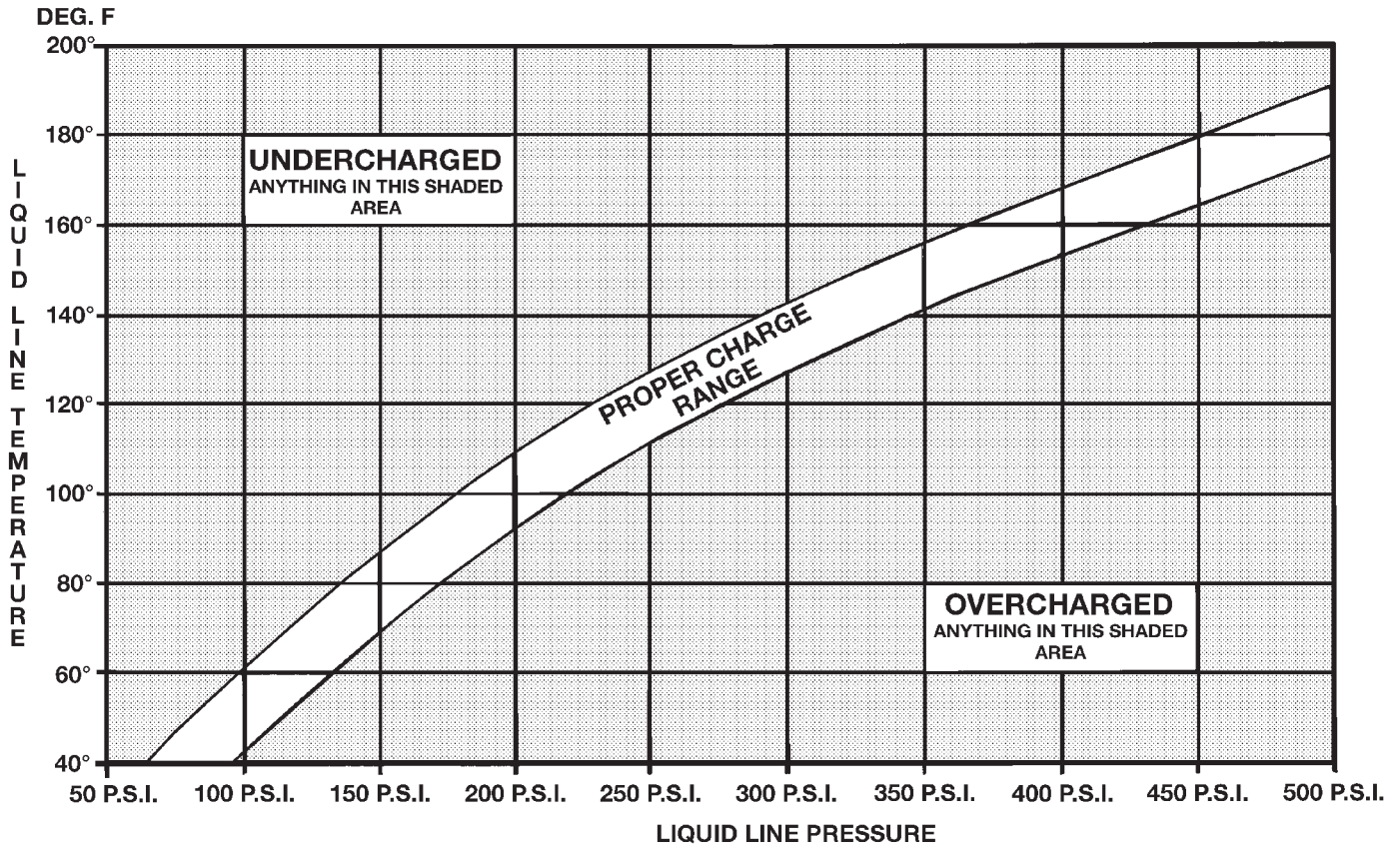

80183484

Fig. 14 Charge Determination Chart

VACUUM CONTROL SYSTEM

Use an adjustable vacuum test set (Special Tool C-3707-B) and a suitable vacuum pump to test the heater-A/C vacuum control system. With a finger placed over the end of the vacuum test hose probe (Fig. 15), adjust the bleed valve on the test set gauge to obtain a vacuum of exactly 27 kPa (8 in. Hg.). Release and block the end of the probe several times to verify that the vacuum reading returns to the exact 27 kPa (8 in. Hg.) setting. Otherwise, a false reading will be obtained during testing.

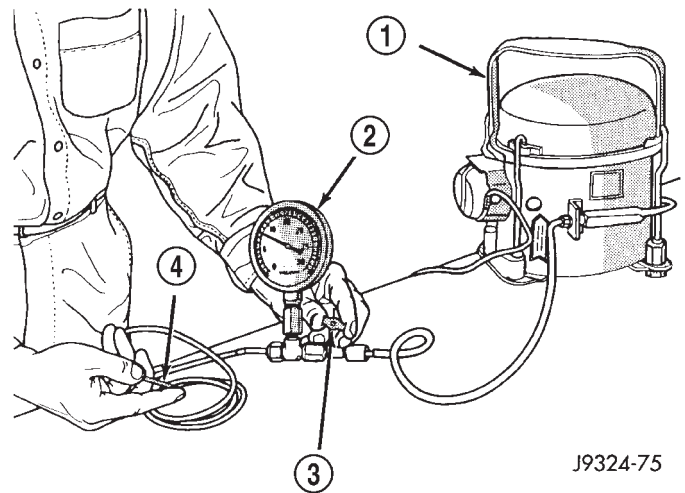

J9324-75

Fig. 15 Adjust Vacuum Test Bleed Valve - Typical

- 1 - VACUUM PUMP TOOL C-4289
- 2 - VACUUM TEST SET C-3707
- 3 - BLEED VALVE
- 4 - PROBE

DIAGNOSIS AND TESTING (Continued)

HEATER-A/C VACUUM SYSTEM DIAGNOSIS

CONDITION	POSSIBLE CAUSES	CORRECTION
NO FORCED AIR IN HEAT POSITION	<ol style="list-style-type: none"> 1. Vacuum line pinched or leaking. 2. Faulty heat defroster or mode door. 3. Faulty selector switch. 4. Vacuum check valve. 	<ol style="list-style-type: none"> 1. Locate and repair vacuum leak or pinched line. 2. Test actuators and door operation. Repair as necessary. 3. Test selector switch and replace if necessary. 4. Test check valve and replace if necessary.
NO FORCED AIR IN PANEL POSITION	<ol style="list-style-type: none"> 1. Vacuum line pinched or leaking. 2. Faulty mode door. 3. Faulty selector switch. 4. Vacuum check valve. 	<ol style="list-style-type: none"> 1. Locate and repair vacuum leak or pinched line. 2. Test actuator and door operation. Repair as necessary. 3. Test selector switch and replace if necessary. 4. Test check valve and replace if necessary.
NO FORCED AIR IN DEFROST POSITION	<ol style="list-style-type: none"> 1. Vacuum line pinched or leaking. 2. Faulty heat, defroster, or mode door. 3. Faulty selector switch. 4. Vacuum check valve. 	<ol style="list-style-type: none"> 1. Locate and repair vacuum leak or pinched line. 2. Test actuators and door operation. Repair as necessary. 3. Test selector switch and replace if necessary. 4. Test check valve and replace if necessary.

ONE-WAY CHECK VALVE

(1) Disconnect the heater-A/C vacuum supply (Black) tube in the engine compartment. This tube passes through an opening in the dash panel.

(2) Remove the one-way vacuum check valve. The valve is located on the (Black) vacuum supply hose at the brake power booster.

(3) Connect the test set vacuum supply hose to the heater side of the valve. When connected to this side of the check valve, no vacuum should pass and the test set gauge should return to the 27 kPa (8 in. Hg.) setting. If OK, go to step Step 4. If not OK, replace the faulty valve.

(4) Connect the test set vacuum supply hose to the engine vacuum side of the valve. When connected to this side of the check valve, vacuum should flow through the valve without restriction. If not OK, replace the faulty valve.

HEATER-A/C CONTROLS

The operation of the Circulation door can be viewed by removing the blower motor and looking up into the unit inlet. See Blower Motor Wheel and Assembly removal and installation in this section for service procedures.

(1) Connect the test set vacuum probe to the heater-A/C vacuum supply (Black) hose in the engine compartment. Position the test set gauge so that it can be viewed from the passenger compartment.

(2) Start with the Mode control in the Panel position and the Circulation control in the Outside-air position.

(3) Move the Circulation control to the Recirculation position (the Circulation door should move into

the Recirculation position). After a short pause move the Mode control to the Defrost position (the Circulation door should move to the Outside-air position). The test gauge should return to the calibrated setting of 27 kPa (8 in. Hg.) after each selection is made. If the gauge cannot achieve the calibrated setting, the vacuum circuit or a component has a leak.

(4) If the gauge achieves the calibrated setting but the door does not move, there is either a pinched vacuum line or a failed actuator.

LOCATING VACUUM LEAKS

(1) Connect the test vacuum probe to the vehicles (Black) supply hose. Position the vacuum test gauge so it can be viewed from the passenger compartment.

(2) Place the Mode in the Panel position and the Circulation control in the Recirculation position.

(3) Remove the center instrument panel bezel.

(4) Remove the center vent duct.

(5) Remove and block the Supply (Black) vacuum line at the control. The test gauge should return to the calibrated setting of 27 kPa (8 in. Hg.). If not, there is a leak in the Supply line.

(6) If there is no leak in the Supply line, reconnect it to the Control and remove the Actuator Feed (Red) line from the Control. Block the vacuum connection on the Control from where the line was removed. The test gauge should return to the calibrated setting of 27 kPa (8 in. Hg.). If not, there is a leak in the Control.

(7) If there is no leak in the Supply line or the Control, reconnect the Actuator Feed (Red) line to the control. Remove and block the Actuator Feed (Red) line at the Actuator. The actuator vacuum port is accessible behind and above the Glove Box. The test

DIAGNOSIS AND TESTING (Continued)

gauge should return to the calibrated setting of 27 kPa (8 in. Hg.). If not there is a leak in the Actuator Feed line.

(8) If there is no leak in the Supply line, Control, or the Actuator Feed line, the leak must be in the Actuator itself. Connect the Vacuum hose from the Vacuum Test Gauge directly to the Actuator to verify the leak.

LOCATING PINCHED VACUUM LINES

The operation of the Circulation door can be viewed by removing the blower motor and looking up into the unit inlet. See Blower Motor Wheel and Assembly removal and installation in this section for service procedures.

(1) Connect the test vacuum probe to the vehicles (Black) supply hose. Position the vacuum test gauge so it can be viewed from the passenger compartment.

(2) Place the Mode in the Panel position and the Circulation control in the Recirculation position.

(3) Remove the center instrument panel bezel.

(4) Remove the center vent duct.

(5) Remove the Supply (Black) vacuum line at the control. The test gauge should drop indicating free flow through the Supply line. If not, there is a blockage in the Supply line.

(6) If there is no blockage in the Supply line, reconnect it to the Control. Remove the Actuator Feed (Red) line from the Control. The test gauge should drop indicating free flow through the Supply line and Control. If not the vacuum switches on the Control are not functioning.

(7) If there is no blockage in the Supply line or the Control, reconnect the Actuator Feed (Red) line to the control. Remove the Actuator Feed (Red) line at the Actuator. The Actuator vacuum port is accessible behind and above the Glove Box. The test gauge should drop indicating free flow through the supply line, Control, and the Actuator Feed line. If not, there is a blockage in the Actuator Feed line.

(8) If there is no blockage in the Supply line, Control, or the Actuator Feed line, the Actuator must have failed. Connect the Vacuum hose from the Vacuum Test Gauge directly to the Actuator to verify the Actuator has failed.

SERVICE PROCEDURES

CHARGING A/C SYSTEM

PARTIAL CHARGE

This vehicle does not have a sight glass. It is not possible to determine the amount of (R-134a) charge in the system. Therefore it is necessary to completely evacuate and recover the system, and then recharge the system fully.

EVACUATION

Before adding refrigerant, all air must be evacuated from the system.

- Connect a manifold gauge set to the A/C service ports (Fig. 16).
- Use a vacuum pump or charging station and evacuate system to 95 kPa (28 inches Hg) for 30 minutes.
- Go to Charging A/C System below.

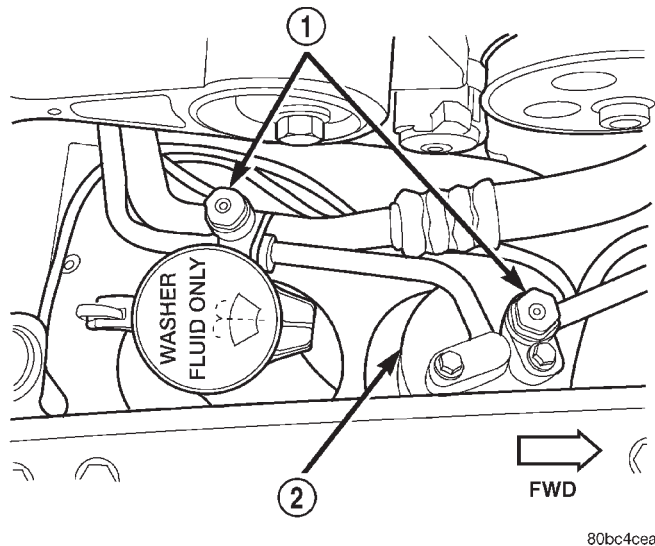

Fig. 16 A/C Service Ports

- 1 - A/C SERVICE PORTS
- 2 - FILTER/DRIER

CHARGING A/C SYSTEM

The procedure below should be used to fill the refrigerant charge in the air conditioning system. This A/C system does not have or use a sight glass to check or charge the system.

WARNING: REVIEW SAFETY PRECAUTIONS AND WARNINGS IN THIS GROUP BEFORE CHARGING THE REFRIGERANT SYSTEM.

AVOID BREATHING A/C REFRIGERANT AND LUBRICANT VAPOR OR MIST. EXPOSURE MAY IRRITATE EYES, NOSE AND THROAT. USE ONLY APPROVED SERVICE EQUIPMENT MEETING SAE REQUIREMENTS TO DISCHARGE R-134a SYSTEM. IF ACCIDENTAL SYSTEM DISCHARGE OCCURS, VENTILATE WORK AREA BEFORE RESUMING SERVICE.

R-134a SERVICE EQUIPMENT OR VEHICLE A/C SYSTEM SHOULD NOT BE PRESSURE TESTED OR LEAK TESTED WITH COMPRESSED AIR. MIXTURE OF AIR and R-134a CAN BE COMBUSTIBLE AT ELEVATED PRESSURES. THESE MIXTURES ARE POTENTIALLY DANGEROUS AND MAY RESULT IN FIRE OR EXPLOSION CAUSING INJURY OR PROPERTY DAMAGE.

SERVICE PROCEDURES (Continued)

CAUTION: Do not overcharge refrigerant system, as excessive compressor head pressure can cause noise and system failure.

After the system has been tested for leaks and evacuated, a refrigerant (R-134a) charge can be injected into the system.

NOTE: When connecting the service equipment coupling to the line fitting, verify that the valve of the coupling is fully closed. This will reduce the amount of effort required to make the connection.

(1) If using a separate vacuum pump close all valves before disconnecting pump. Connect manifold gauge set to the A/C service ports (Fig. 16).

NOTE: The air conditioning system in this vehicle holds (27 oz. or 1.69 lbs.) of R-134a refrigerant.

(2) Measure refrigerant (refer to capacities). Refer to the instructions provided with the equipment being used.

(3) Verify engine is shut off. Open the suction and discharge valves. Open the charge valve to allow the refrigerant to flow into the system. When the transfer of refrigerant has stopped, close the suction and discharge valve.

(4) If all of the charge did not transfer from the dispensing device, put vehicle controls into the following mode:

- Automatic transaxle in park or manual transaxle in neutral
- Engine idling at 700 rpm
- A/C control set in 100 percent outside air
- Panel mode
- Blower motor ON high speed
- Vehicle windows closed

If the A/C compressor does not engage, test the compressor clutch control circuit and correct any failure. Refer to Group 8W, Wiring Diagrams.

(5) Open the suction valve to allow the remaining refrigerant to transfer to the system.

WARNING: TAKE CARE NOT TO OPEN THE DISCHARGE (HIGH-PRESSURE) VALVE AT THIS TIME.

(6) Close all valves and test the A/C system performance.

(7) Disconnect the charging station or manifold gauge set. Install the service port caps.

EVACUATING REFRIGERANT SYSTEM

NOTE: Special effort must be used to prevent moisture from entering the A/C system oil. Moisture in the oil is very difficult to remove and will cause a reliability problem with the compressor.

If a compressor designed to use R-134a refrigerant is left open to the atmosphere for an extended period of time. It is recommended that the refrigerant oil be drained and replaced with new oil or a new compressor be used. This will eliminate the possibility of contaminating the refrigerant system.

If the refrigerant system has been open to the atmosphere, it must be evacuated before the system can be filled. Moisture and air mixed with the refrigerant will raise the compressor head pressure above acceptable operating levels. This will reduce the performance of the air conditioner and damage the compressor. Moisture will boil at near room temperature when exposed to vacuum. To evacuate the refrigerant system:

NOTE: When connecting the service equipment coupling to the line fitting, verify that the valve of the coupling is fully closed. This will reduce the amount of effort required to make the connection.

(1) Connect a suitable charging station, refrigerant recovery machine, and a manifold gauge set with vacuum pump (Fig. 17).

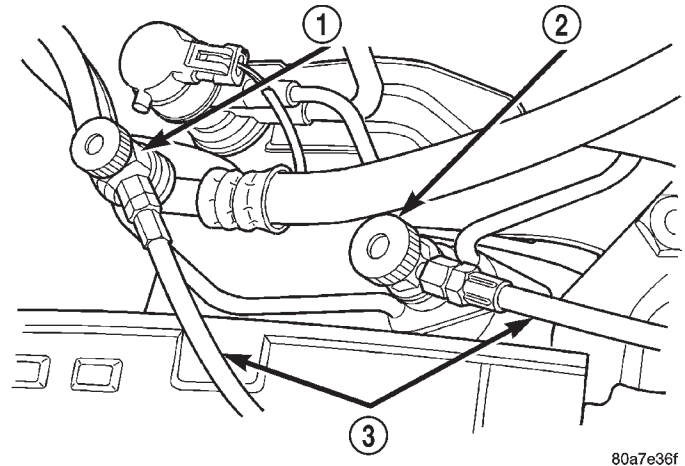

80a7e36f

Fig. 17 Refrigerant Recovery Machine Hookup - Typical

- 1 - LOW SIDE CONNECTOR
- 2 - HIGH SIDE CONNECTOR
- 3 - TO MANIFOLD SET

(2) Open the suction and discharge valves and start the vacuum pump. The vacuum pump should run a minimum of 45 minutes prior to charge to eliminate all moisture in system. When the suction gauge reads -88 kPa (-26 in. Hg) vacuum or greater for 45 minutes, close all valves and turn off vacuum pump. If the system fails to reach specified vacuum, the refrigerant system likely has a leak that must be corrected. If the refrigerant system maintains specified vacuum for at least 30 minutes, start the vacuum pump, open the suction and discharge valves.

SERVICE PROCEDURES (Continued)

Then allow the system to evacuate an additional 10 minutes.

(3) Close all valves. Turn off and disconnect the vacuum pump.

(4) The refrigerant system is prepared to be charged with refrigerant.

R-134a REFRIGERANT

This vehicle uses a refrigerant called R-134a. It is a non-toxic, non-flammable, clear colorless liquefied gas.

R-134a refrigerant is not compatible with R-12 refrigerant in an air conditioning system. Even a small amount of R-12 in a R-134a system could cause compressor failure, refrigerant oil to sludge and/or poor performance. **Never add any other type of refrigerant to a system designed to use R-134a refrigerant. System failure will occur.**

The high pressure service port is located on the filter/drier. The low pressure service port is located on the suction line near the strut tower.

When servicing a system, it is required that an air conditioning charging recovery/recycling machine be used (Fig. 18). Contact an automotive service equipment supplier for proper equipment. Refer to the operating instructions provided with the equipment for proper operation.

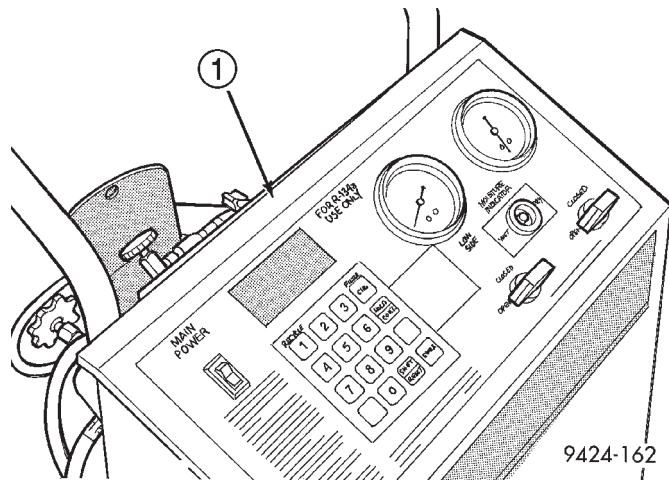

Fig. 18 Refrigerant Recovery/Recycling Station - Typical

1 - R-134 REFRIGERANT RECOVERY MACHINE

A manifold gauge set (Fig. 19) must also be used in conjunction with the charging and/or recovery/recycling device. Only use gauges that have not been used for R-12. The service hoses on the gauge set should have manual (turn wheel) or automatic back flow valves at the service port connector ends. This will prevent refrigerant R-134a from being released into the atmosphere.

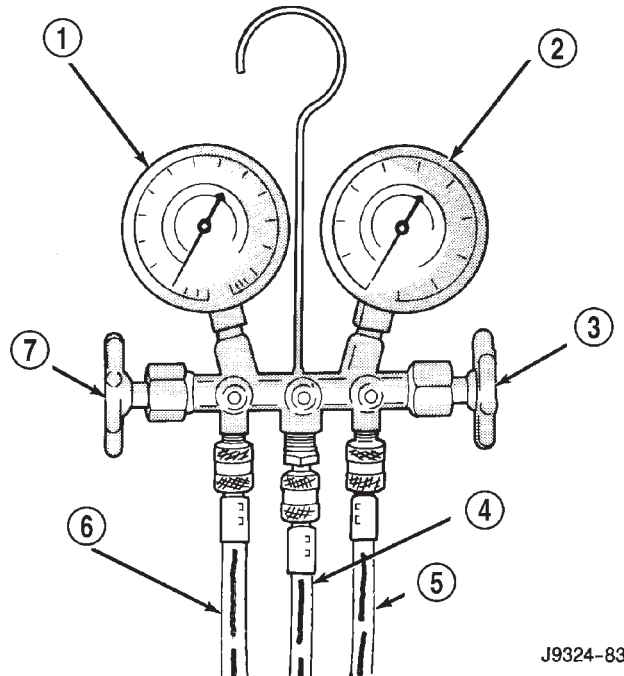

Fig. 19 Manifold Gauge Set - Typical

- 1 - LOW PRESSURE GAUGE
- 2 - HIGH PRESSURE GAUGE
- 3 - VALVE
- 4 - VACUUM/REFRIGERANT HOSE (YELLOW W/BLACK STRIP)
- 5 - HIGH PRESSURE HOSE (RED W/BLACK STRIP)
- 6 - LOW PRESSURE HOSE (BLUE W/BLACK STRIP)
- 7 - VALVE

R-134a refrigerant requires a special type of compressor oil. When adding oil, make sure to use the oil that is specified on the under hood label.

The use of R-134a will have a positive environmental impact due to its zero ozone depletion and low global warming impact.

SERVICING REFRIGERANT OIL LEVEL

CAUTION: The refrigerant oil used in a R-134a A/C system is unique. Use only oils which were designed to work with R-134a refrigerant. The oil designated for this vehicle is ND8 PAG (polyalkylene glycol).

Recovery/recycling equipment will measure the lubricant being removed. This is the amount of lubricant to be added back to the system. If a new compressor is being installed, drain lubricant from old compressor, measure the amount drained and discard old lubricant. Drain the lubricant from the new compressor into a clean container. Return the amount of lubricant measured from the old compressor, plus the amount reclaimed from the system back into the new compressor.

SERVICE PROCEDURES (Continued)

(1) Discharge refrigerant system using recovery/recycling equipment if charge is present.

(2) Disconnect refrigerant lines from A/C compressor. Cap the open lines to prevent moisture from entering system.

(3) Remove compressor from vehicle.

(4) From suction port on top of compressor, drain lubricant from compressor.

(5) Add system capacity minus the capacity of components that have not been replaced. Refer to the Lubricant Capacity Chart. Add lubricant through the suction port on compressor. This is not to exceed 180 ml (6.10 oz.) in total.

(6) Install compressor and connect refrigerant lines. Then evacuate and charge refrigerant system.

SYSTEM LEAK CHECKING

WARNING: R-134a SERVICE EQUIPMENT OR VEHICLE A/C SYSTEM SHOULD NOT BE PRESSURE TESTED OR LEAK TESTED WITH COMPRESSED AIR. MIXTURE OF AIR and R-134a CAN BE COMBUSTIBLE AT ELEVATED PRESSURES. THESE MIXTURES ARE POTENTIALLY DANGEROUS AND MAY RESULT IN FIRE OR EXPLOSION CAUSING INJURY OR PROPERTY DAMAGE.

AVOID BREATHING A/C REFRIGERANT AND LUBRICANT VAPOR OR MIST. EXPOSURE MAY IRRITATE EYES, NOSE AND THROAT. USE ONLY APPROVED SERVICE EQUIPMENT MEETING SAE REQUIREMENTS TO DISCHARGE R-134a SYSTEM. IF ACCIDENTAL SYSTEM DISCHARGE OCCURS, VENTILATE WORK AREA BEFORE RESUMING SERVICE.

If the A/C system is not cooling properly, determine if the refrigerant system is fully charged with R-134a. This is accomplished by performing a system Charge Level-Check or Fill. If while performing this test A/C liquid line pressure is less than 345 kPa (50 psi) proceed to Empty Refrigerant System Leak Test. If liquid line pressure is greater than 345 kPa (50 psi) proceed to low refrigerant level leak test. If the refrigerant system is empty or low in refrigerant charge, a leak at any line fitting or component seal is likely. A review of the fittings, lines and components for oily residue is an indication of the leak location. To detect a leak in the refrigerant system, perform one of the following procedures as indicated by the symptoms.

EMPTY REFRIGERANT SYSTEM LEAK TEST

(1) Evacuate the refrigerant system to the lowest degree of vacuum possible (approx. 28 in Hg.). Determine if the system holds a vacuum for 15 minutes. If vacuum is held, a leak is probably not present. If sys-

tem will not maintain vacuum level, proceed with this procedure.

(2) Prepare a.284 Kg. (10 oz.) refrigerant charge to be injected into the system.

(3) Connect and dispense.284 Kg. (10 oz.) of refrigerant into the evacuated refrigerant system.

(4) Proceed to Step 2 of Low Refrigerant Level Leak Test.

LOW REFRIGERANT LEVEL LEAK TEST

(1) Determine if there is any (R-134a) refrigerant in the system.

(2) Position the vehicle in a wind free work area. This will aid in detecting small leaks.

(3) Bring the refrigerant system up to operating temperature and pressure. This is done by allowing the engine to run for five minutes with the system set to the following:

- Transaxle in Park
- Engine Idling at 700 rpm
- A/C Controls Set in 100 percent outside air
- Blower switch in the high A/C position
- A/C in the ON position
- Open all windows

CAUTION: A leak detector designed for R-12 refrigerant (only) will not detect leaks in a R-134a refrigerant system.

(4) Shut off the vehicle and wait 2 to 7 minutes. Then use an Electronic Leak Detector that is designed to detect R-134a type refrigerant and search for leaks. Fittings, lines, or components that appear to be oily usually indicates a refrigerant leak. To inspect the evaporator core for leaks, insert the leak detector probe into the drain tube opening or a heat duct. A R-134a dye is available to aid in leak detection, use only Chrysler approved refrigerant dye.

If a thorough leak check has been completed without indication of a leak, proceed to System Charge Level.

REMOVAL AND INSTALLATION

A/C FILTER/DRIER

The filter/drier is mounted in a rubber grommet on the right side of the engine compartment. The refrigerant must be recovered from the A/C system before replacing the filter/drier assembly.

WARNING: THE REFRIGERATION SYSTEM MUST BE COMPLETELY RECOVERED BEFORE PROCEEDING WITH THIS OPERATION.

REMOVAL AND INSTALLATION (Continued)

REMOVAL

- (1) Disconnect liquid line from filter/drier.
- (2) Disconnect liquid line on suction line assembly from filter/drier.
- (3) Pull filter/drier out of rubber grommet.

INSTALLATION

For installation, reverse the above procedures.

A/C SERVICE PORT VALVE CORES

REMOVAL

- (1) Remove the valve caps (Fig. 4).
- (2) Using a R-134a refrigerant recovery machine, Remove the refrigerant from A/C system.
- (3) Using a standard valve core tool, remove the valve core. **Be careful to prevent any dirt/debris from entering the valve core opening or getting on the replacement valve core.**

INSTALLATION

- (1) When assembling the new valve core into the port, the core should be oiled with clean ND8 PAG compressor oil.

CAUTION: A valve that is not fully seated can lead to damage to the valve during evacuation and charge. This can result in system refrigerant discharge while uncoupling the charge adapters.

- (2) Install valve core into port.
- (3) Evacuate and charge the A/C system.
- (4) Install the valve caps.

BLOWER MOTOR AND WHEEL ASSEMBLY

The blower motor is located on the bottom right side of the unit housing. The blower motor can be removed from the vehicle without having to remove the unit housing assembly.

WITH AIR CONDITIONING

REMOVAL

- (1) Remove right side scuff plate.
- (2) Pull back carpet.
- (3) Disconnect blower motor wiring connector.
- (4) Remove blower motor retaining screws, and lower blower motor assembly from unit housing (Fig. 20).

INSTALLATION

For installation, reverse the above procedures.

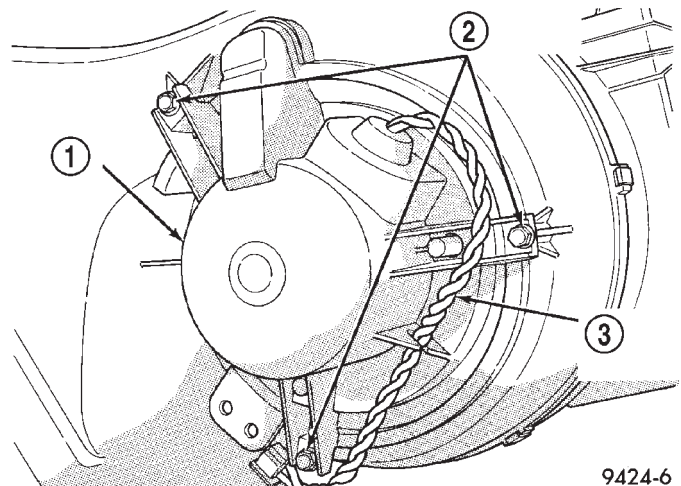

Fig. 20 Blower Motor Retaining Screws

- 1 - BLOWER MOTOR
- 2 - BLOWER MOTOR RETAINING SCREWS
- 3 - BLOWER MOTOR WIRING

9424-6

WITHOUT AIR CONDITIONING

REMOVAL

- (1) Disconnect blower motor wiring connector.
- (2) Grasp the blower motor while pulling down tab. Turn approximately 1/8 turn counterclockwise and remove blower motor assembly from unit housing (Fig. 21).

INSTALLATION

For installation, reverse the above procedures.

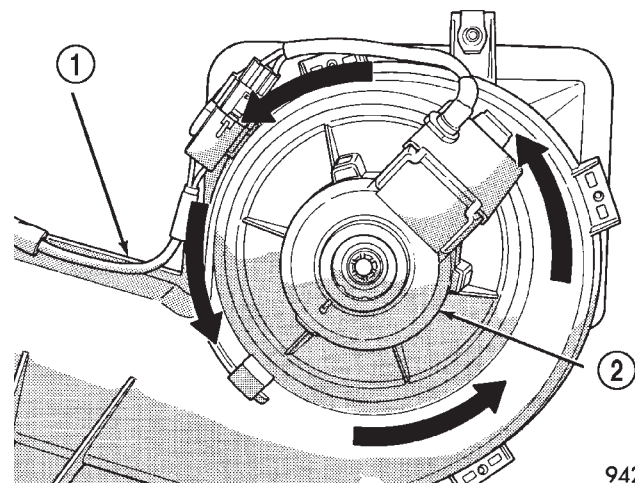

Fig. 21 Blower Motor Removal

- 1 - BLOWER MODULE
- 2 - BLOWER MOTOR

9424-7

REMOVAL AND INSTALLATION (Continued)

BLOWER MOTOR RESISTOR

CAUTION: Stay clear of the blower motor and resistor block (Hot). Do not operate the blower motor with the resistor block removed.

REMOVAL

- (1) Remove windshield wipers.
- (2) Remove cowl top screen.
- (3) Disconnect the resistor block wiring connector (Fig. 22).

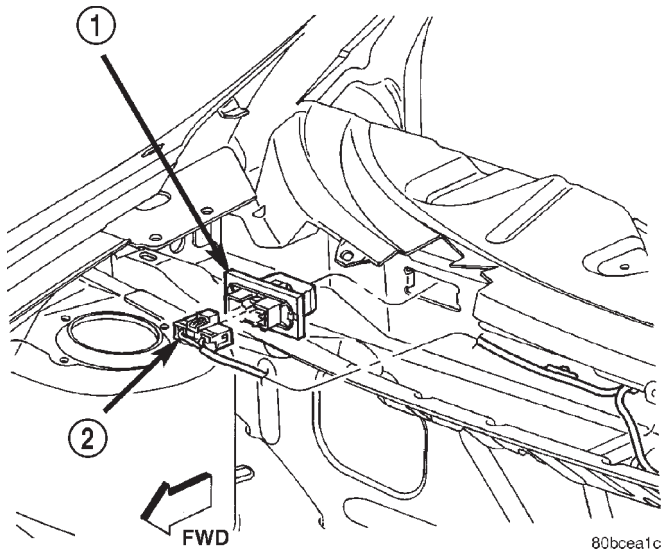

Fig. 22 Blower Motor Resistor Block

- 1 - RESISTOR BLOCK
2 - ELECTRICAL CONNECTOR

- (4) Remove/unsnap resistor block from vehicle.

INSTALLATION

For installation, reverse the above procedures.

BLOWER MOTOR WHEEL

The blower motor wheel is only serviced with the blower motor. The wheel and the motor are balanced as an assembly. If the blower motor wheel requires replacement, the blower motor must also be replaced. Refer to blower motor for replacement procedure.

COMPRESSOR

CAUTION: Add only new lubricant when system requires additional lubricant. Do not use old reclaimed lubricant.

REMOVAL

The A/C compressor may be unbolted and repositioned without discharging the refrigerant system. Discharging is not necessary if removing the compressor clutch/coil assembly, engine, cylinder head, or alternator.

WARNING: REFRIGERANT PRESSURES REMAIN HIGH EVEN THOUGH THE ENGINE MAY BE TURNED OFF. DO NOT TWIST OR KINK THE REFRIGERANT LINES WHEN REMOVING A FULLY CHARGED COMPRESSOR. SAFETY GLASSES MUST BE WORN.

- (1) Disconnect battery negative cable.
- (2) Loosen and remove drive belts, refer to Group 7, Engine Cooling.
- (3) Using a R-134a refrigerant recovery machine, remove the refrigerant from A/C system. If the compressor is being replaced.
- (4) Disconnect compressor clutch wire lead.
- (5) Remove refrigerant lines from compressor, if necessary (Fig. 23).

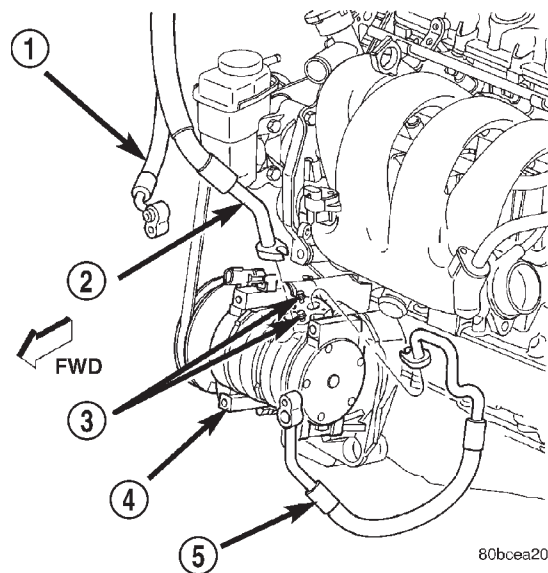

Fig. 23 A/C Compressor Lines

- 1 - CONDENSER LIQUID LINE
2 - SUCTION LINE
3 - COMPRESSOR MANIFOLD SCREWS
4 - COMPRESSOR
5 - DISCHARGE LINE

- (6) If system is left open place plug/cap over open lines.
- (7) Remove compressor attaching bolts (Fig. 24).

REMOVAL AND INSTALLATION (Continued)

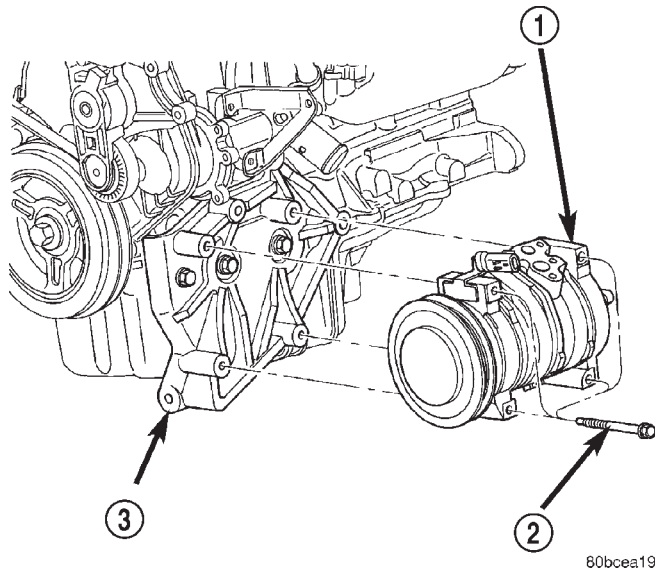

Fig. 24 A/C Compressor Mounting Bolts

- 1 - A/C COMPRESSOR
- 2 - MOUNTING BOLTS
- 3 - LOWER FRONT STRUT-TO-ENGINE BRACKET

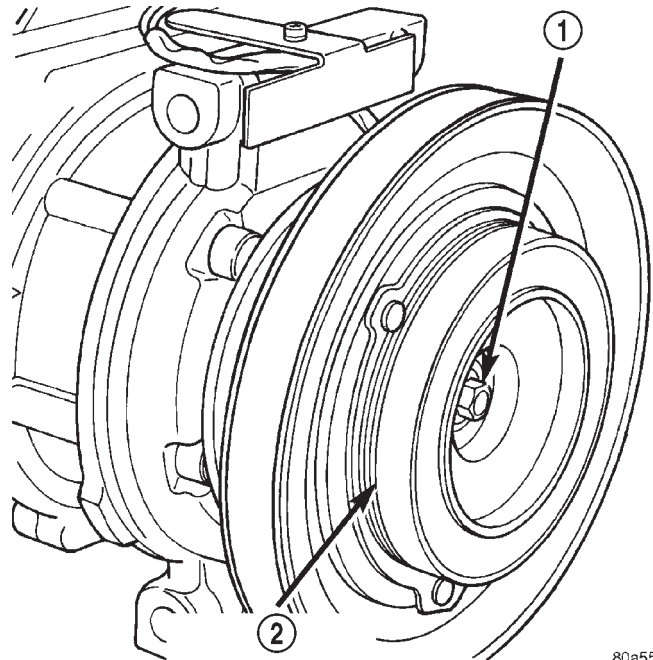

Fig. 25 Compressor Shaft Bolt and Clutch Plate

- 1 - COMPRESSOR SHAFT BOLT
- 2 - COMPRESSOR CLUTCH PLATE

(8) Remove compressor. If refrigerant lines were not removed, lift compressor/clutch assembly and tie it to a suitable component.

INSTALLATION

For installation, reverse the above procedures.

- Tighten the compressor mounting bolts to 28 N·m (250 in lbs).
- Tighten the compressor lines to 12 N·m (108 in lbs).

COMPRESSOR CLUTCH/COIL ASSEMBLY

Compressor assembly must be removed from mounting. Although, refrigerant discharge is not necessary.

REMOVAL

(1) Remove the compressor shaft bolt (Fig. 25). A band type oil filter removal tool can be placed around the clutch plate to aid in bolt removal.

(2) Tap the clutch plate with a plastic hammer and remove clutch plate and shim(s) (Fig. 26).

NOTE: Use care not to lose any of the shim(s).

CAUTION: Do not use screwdrivers between the clutch plate assembly and pulley to remove front plate as this may damage the front plate assembly.

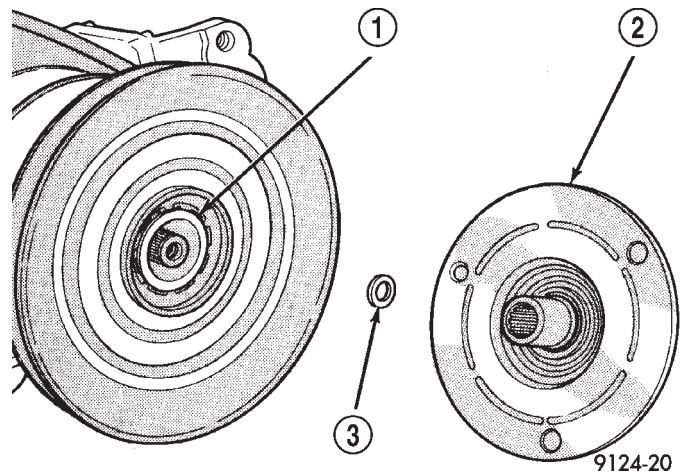
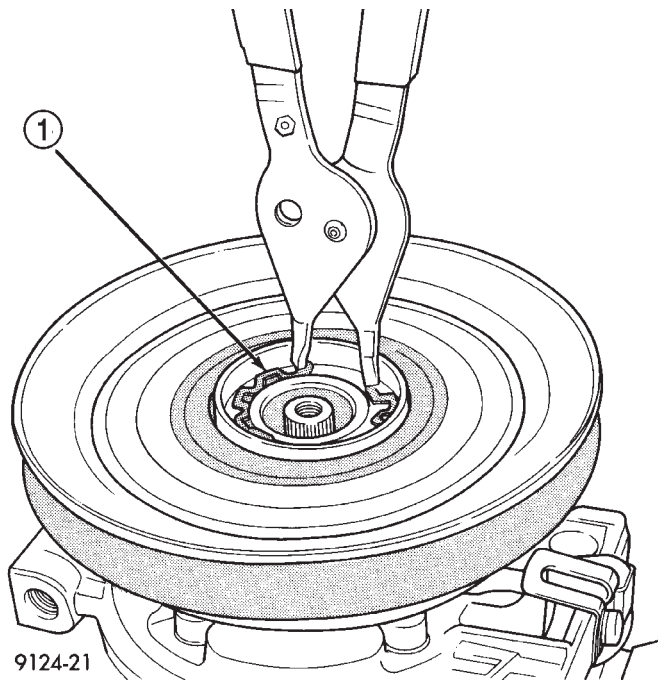

Fig. 26 Clutch Plate and Shim(s)

- 1 - COMPRESSOR SHAFT
- 2 - CLUTCH PLATE
- 3 - CLUTCH PLATE SHIM

REMOVAL AND INSTALLATION (Continued)

(3) Remove pulley retaining snap ring with Snap Ring Pliers, and slide pulley assembly off of compressor (Fig. 27).



9124-21

Fig. 27 Removing Pulley Snap Ring

1 - SNAP RING

(4) Remove coil wire bracket/ground clip screw and wire harness.

(5) Remove snap ring retaining field coil onto compressor housing (Fig. 28). Slide field coil off of compressor housing.

(6) Examine frictional faces of the clutch pulley and front plate for wear. The pulley and front plate should be replaced if there is excessive wear or scoring. If the friction surfaces are oily, inspect the shaft nose area of the compressor for oil and remove the felt from the front cover. If the compressor felt is saturated with oil, the shaft seal is leaking and will have to be replaced.

(7) Check bearing for roughness or excessive leakage of grease. Replace bearing as required.

INSTALLATION

(1) Align pin in back of field coil with hole in compressor end housing, and position field coil into place. Make sure that lead wires are properly routed, and fasten the coil wire bracket/ground retaining screw.

NOTE: A new snap ring must be used. The bevel side of the snap ring must be outward.

(2) Install field coil retaining snap ring with Snap Ring Pliers. Press snap ring to make sure it is properly seated in the groove.

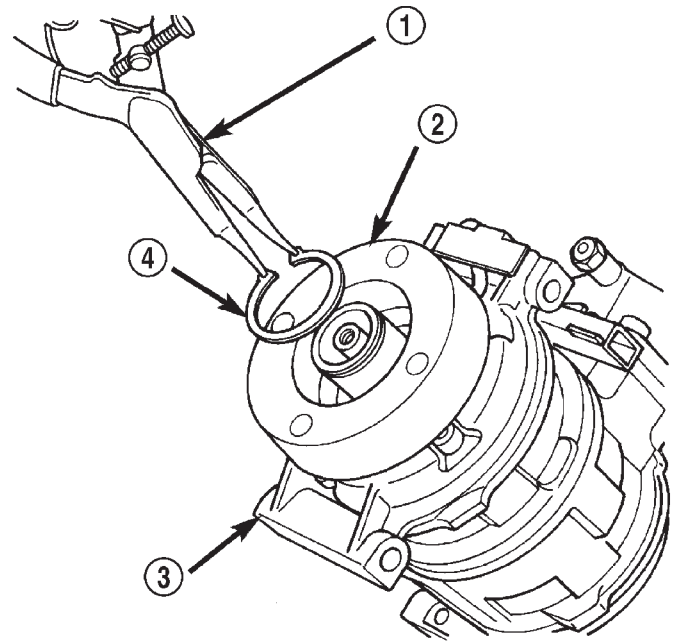

80a5575e

Fig. 28 Clutch Coil Snap Ring

1 - SNAP RING PLIERS

2 - CLUTCH COIL

3 - COMPRESSOR

4 - SNAP RING

CAUTION: If snap ring is not fully seated it will vibrate out, resulting in a clutch failure and severe damage to the front face of the compressor.

Do not mar the pulley frictional surface.

(3) Install pulley assembly to compressor. If necessary, tap gently with a block of wood on the friction surface (Fig. 29).

(4) Install pulley assembly retaining snap ring (bevel side outward) with Snap Ring Pliers. Press the snap ring to make sure it is properly seated in the groove.

(5) If the original front plate assembly and pulley assembly are to be reused, the old shim(s) can be used. If not, place a trial stack of shims, 2.54 mm (0.10 in.) thick, on the shaft against the shoulder.

(6) Install front plate assembly onto shaft.

(7) If installing a new front plate and/or pulley assembly, the gap between front plate and pulley face must be checked. Use the following procedure:

(a) Attach a dial indicator to front plate so that movement of the plate can be measured.

(b) With the dial indicator zeroed on the front plate, energize the clutch and record the amount of movement.

(c) The readings should be 0.35 to 0.65 mm (0.014 to 0.026 in.). If proper reading is not

REMOVAL AND INSTALLATION (Continued)

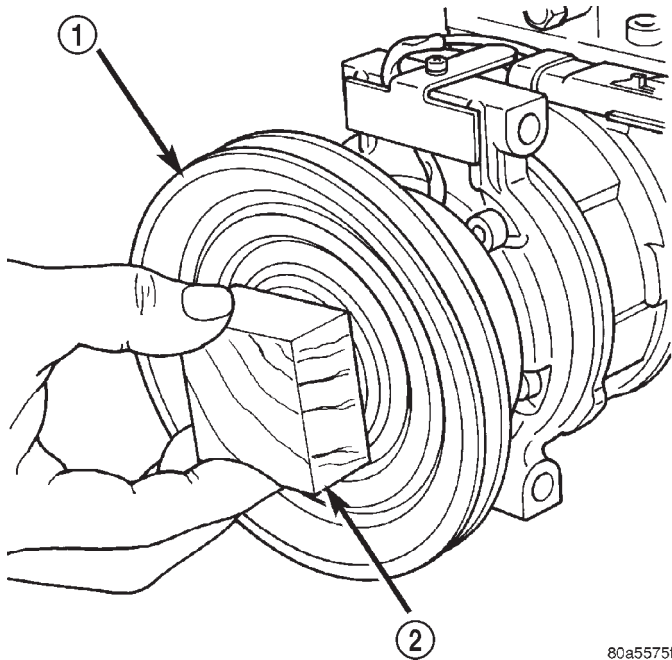

Fig. 29 Installing Pulley Assembly

- 1 - PULLEY ASSEMBLY
- 2 - WOOD BLOCK

80a5575f

obtained, add or subtract shims until desired reading is obtained.

(8) Install compressor shaft bolt. Tighten to 17.5 ± 2 N·m (155 ± 20 in. lbs.) torque.

NOTE: Shims may compress after tightening shaft nut. Check air gap in four or more places to verify if air gap is still correct. Spin pulley for final check.

CLUTCH BREAK-IN

After new clutch installation, cycle the A/C clutch 20 times (5 seconds on and 5 seconds off). During this procedure, set the system to the A/C mode, engine rpm at 1500 - 2000, and high blower speed. This procedure (burnishing) will seat the opposing friction surfaces and provide a higher clutch torque capability.

CONDENSATION DRAIN TUBE

REMOVAL

- (1) Raise vehicle.
- (2) Locate rubber drain tube on right side of dash panel (Fig. 30).
- (3) Squeeze clamp and remove drain tube.

INSTALLATION

To install, reverse the preceding operation. Check the drain tube nipple on the heater-A/C housing for any obstructions.

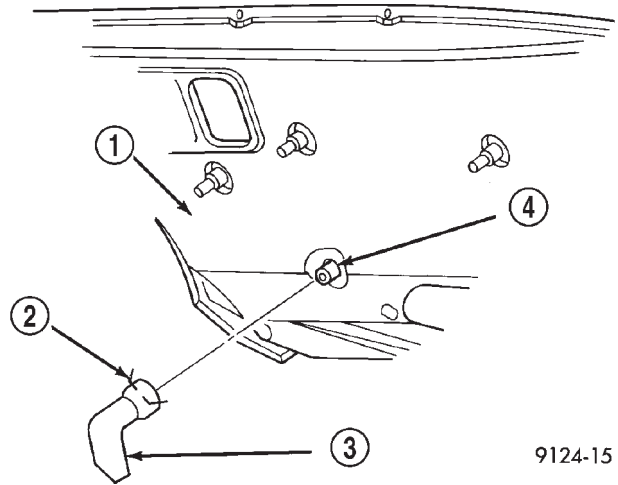

9124-15

Fig. 30 Condensate Water Drain Tube - Typical

- 1 - DASH PANEL (UNDER HOOD RIGHT SIDE)
- 2 - CLAMP
- 3 - CONDENSATE DRAIN TUBE
- 4 - NIPPLE-A/C HEATER HOUSING

CONDENSER

The condenser is located in front of the engine radiator. It has no serviceable parts. If damaged or leaking, the condenser assembly must be replaced.

WARNING: THE REFRIGERANT MUST BE REMOVED FROM THE SYSTEM BEFORE REMOVING THE CONDENSER.

REMOVAL

- (1) Using a R-134a refrigerant recovery machine, remove the refrigerant from the A/C system.
- (2) Remove battery support strut.
- (3) Remove refrigerant lines from condenser (Fig. 31).
- (4) Remove upper radiator mounts.
- (5) Remove condenser to radiator mounting screws.
- (6) Tilt radiator back and remove condenser.

INSTALLATION

For installation, reverse the above procedures.

- Tighten the condenser refrigerant lines to 5 N·m (45 in lbs).

REMOVAL AND INSTALLATION (Continued)

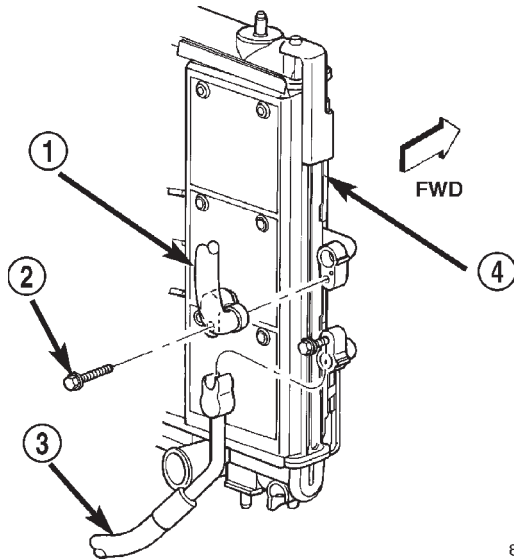

80bcea16

Fig. 31 Condenser Refrigerant Lines

- 1 - LIQUID LINE
- 2 - A/C LINE MOUNTING BOLTS
- 3 - DISCHARGE LINE
- 4 - CONDENSER

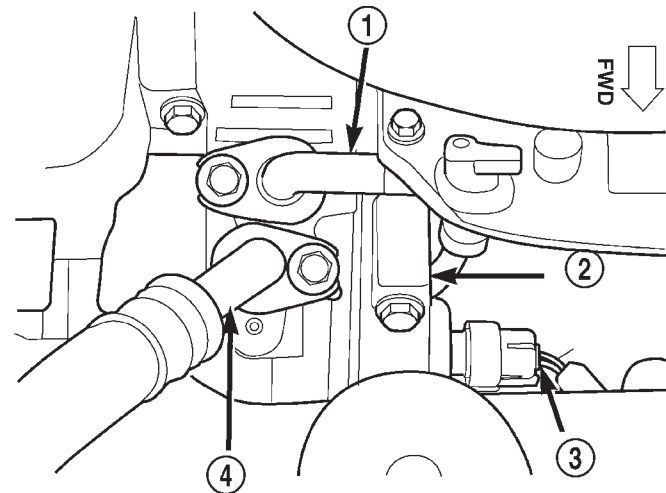

80bcea29

Fig. 32 Discharge Line

- 1 - DISCHARGE LINE
- 2 - A/C COMPRESSOR
- 3 - HIGH PRESSURE CUT OUT SWITCH
- 4 - SUCTION LINE

DISCHARGE LINE

WARNING: THE REFRIGERANT SYSTEM MUST BE RECOVERED BEFORE SERVICING ANY PART OF THE REFRIGERANT SYSTEM.

REMOVAL

- (1) Using a R-134a refrigerant recovery machine, remove the refrigerant from A/C system.
- (2) From the top side of the vehicle, remove line at compressor (Fig. 32).
- (3) From the bottom side of the vehicle, remove line at condenser.

INSTALLATION

For installation, reverse the above procedures.

EVAPORATOR

This vehicle uses an aluminum plate and fin style evaporator. It is located in the Evaporator/Blower module.

The unit housing must be removed from the vehicle before beginning with this procedure. Refer to Unit Housing in this section for removal procedure.

Use this procedure if any or all of the following items require service:

- Evaporator
- Air inlet duct
- Heater Core
- Heating and Air Conditioning

DISASSEMBLE

- (1) Separate the foam seals at the evaporator line connection, and the dash panel air distribution outlets (Fig. 33).
- (2) Disconnect fin sensing probe from harness.
- (3) Remove upper to lower case retaining clip and screws.
- (4) Separate the case halves (Fig. 34).
- (5) Lift the evaporator out of the module (Fig. 35).

ASSEMBLE

To reassemble, reverse the above procedures.

EVAPORATOR PROBE

The evaporator probe can be removed without removing the Unit Housing from the vehicle.

REMOVAL

- (1) Disconnect probe wiring connector from behind the glove box.
- (2) Remove rubber grommet from evaporator/blower module (Fig. 36).
- (3) Note which of the three pilot holes the evaporator probe is located in.
- (4) Pull probe out of evaporator fins.

INSTALLATION

- (1) There are three pilot holes available for the probe. The top hole is for service. If top hole was not used by previous probe, install probe in top hole.
- (2) If previous probe was removed from top hole, use a small plastic stick of approximately 1/8 inch

REMOVAL AND INSTALLATION (Continued)

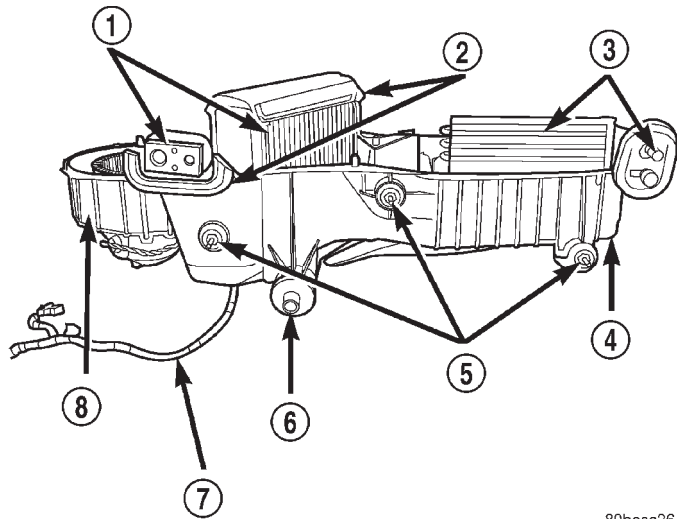

80bcea26

Fig. 33 Lower HVAC Housing

- 1 - EVAPORATOR AND CONNECTION
- 2 - FOAM SEALS
- 3 - HEATER CORE AND TUBES
- 4 - HVAC HOUSING LOWER CASE
- 5 - HOUSING MOUNTING STUDS
- 6 - HOUSING DRAIN
- 7 - WIRING
- 8 - BLOWER MOTOR AND WHEEL

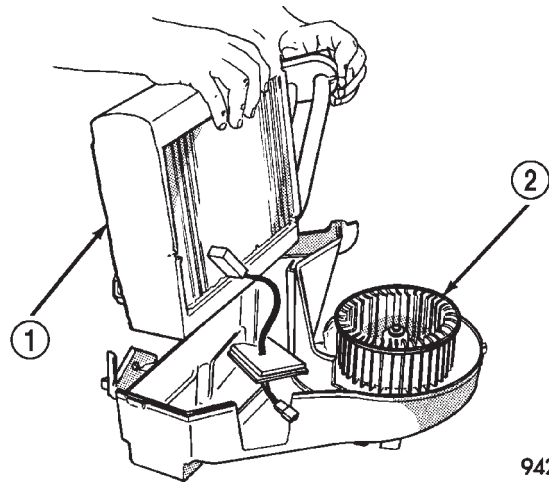

9424-49

Fig. 35 Evaporator Removal - Typical

- 1 - EVAPORATOR
- 2 - BLOWER WHEEL

(3) Insert new probe into hole between evaporator fins.

(4) Reinstall rubber grommet into evaporator probe access hole.

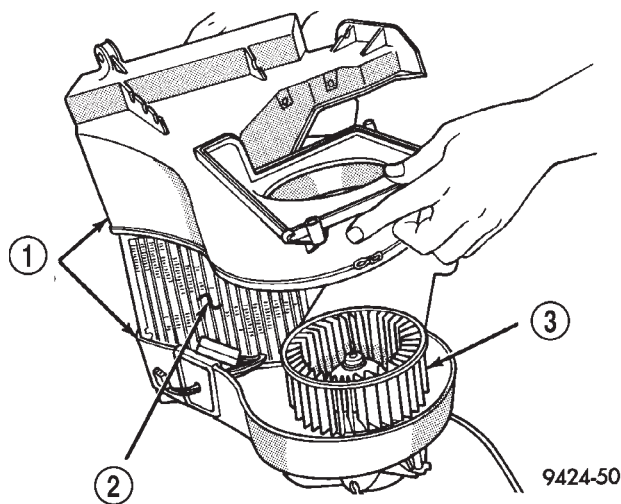

9424-50

Fig. 34 Case Separation - Typical

- 1 - CASE HALVES
- 2 - EVAPORATOR
- 3 - BLOWER WHEEL

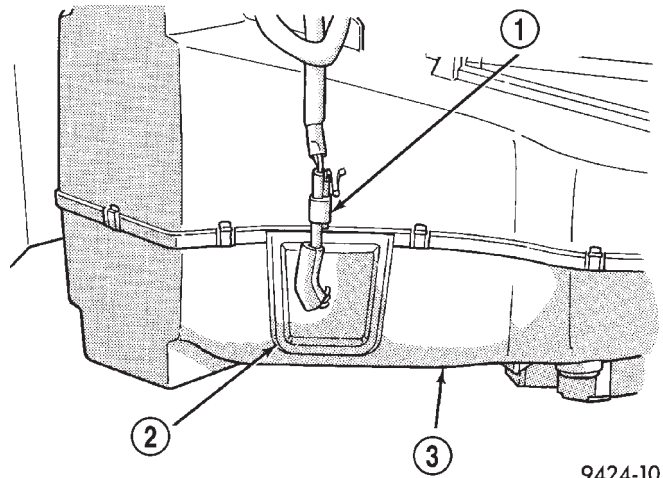

9424-10

Fig. 36 Evaporator Probe Location - Typical

- 1 - EVAPORATOR PROBE WIRING CONNECTOR
- 2 - EVAPORATOR PROBE RUBBER GROMMET
- 3 - EVAPORATOR/BLOWER MODULE

diameter, and make a new hole. Make the hole 1/4 inch above, or below the original hole in the evaporator core.

EXPANSION VALVE

WARNING: THE REFRIGERATION SYSTEM MUST BE COMPLETELY EMPTY BEFORE PROCEEDING WITH THIS OPERATION.

REMOVAL AND INSTALLATION (Continued)

REMOVAL

- (1) Remove the wire connector from the low pressure cut-off switch.
- (2) Remove the center bolt of refrigerant line plumbing sealing plate (Fig. 37).
- (3) Carefully pull the refrigerant line-sealing plate assembly from the expansion valve towards front of vehicle. Do not scratch the expansion valve sealing surfaces with pilot tubes.
- (4) Cover the openings on A/C line-sealing plate assembly to prevent contamination.
- (5) Remove two screws securing the expansion valve to the evaporator sealing plate.
- (6) Carefully remove valve.

INSTALLATION

- (1) Remove and replace the aluminum gasket on the evaporator sealing plate.
- (2) Carefully hold the expansion valve to the evaporator sealing plate so not to scratch the sealing surface. Install two screws and tighten to 11 ± 3 N·m (100 ± 30 in. lbs.).
- (3) Remove and replace the aluminum gasket on the refrigerant line-sealing plate assembly.
- (4) Carefully hold the refrigerant line-sealing plate assembly to the expansion valve. Install bolt and tighten to 23 ± 3 N·m (200 ± 30 in. lbs.).
- (5) Connect wires to low pressure cut-off switch.
- (6) Evacuate and recharge system.
- (7) After expansion valve is installed, system is charged, and leaks have been checked, repeat A/C performance check.

HEATER CORE

Refer to HVAC Housing Disassembly and Assembly in this section for heater core removal procedure.

HEATER HOSES

CAUTION: When removing hoses from heater core inlet or outlet nipples DO NOT exert excess pressure. The heater core may become damaged and leak engine coolant.

NOTE: Review Cooling System Precautions before proceeding with this operation.

REMOVAL

- (1) Drain engine cooling system. Refer to Group 7, Cooling System.
- (2) Using spring tension clamp pliers, remove clamps at end of heater hose to be removed (Fig. 38).
- (3) Carefully rotate hose back and forth while pulling away from connector nipple.

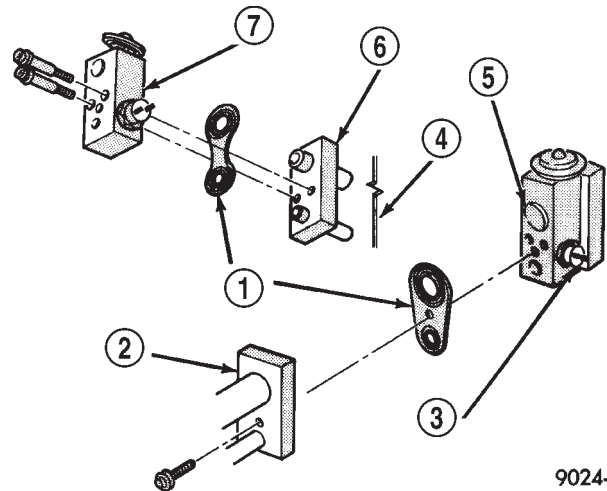

9024-40

Fig. 37 Expansion Valve - Typical

- 1 - ALUMINUM N-GASKET
- 2 - PLUMBING SEALING PLATE
- 3 - LOW/DIFFERENTIAL PRESSURE CUT-OFF SWITCH
- 4 - DASH PANEL
- 5 - H-VALVE
- 6 - EVAPORATOR SEALING PLATE
- 7 - H-VALVE

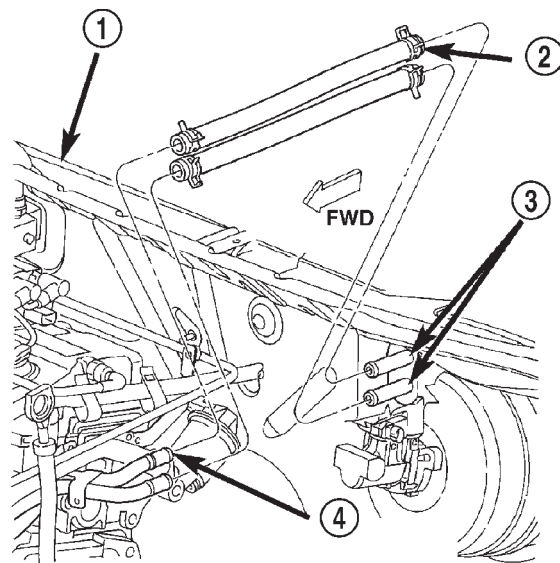

80bcea2*

Fig. 38 Heater Hoses and Clamps

- 1 - COWL PANEL
- 2 - HEATER HOSE AND CLAMPS
- 3 - HEATER CORE TUBES
- 4 - HEATER HOSE SUPPLY AND RETURN TUBES

INSTALLATION

For installation, reverse the above procedures.

REMOVAL AND INSTALLATION (Continued)

HIGH PRESSURE CUT OUT SWITCH

WARNING: THE REFRIGERANT MUST BE REMOVED FROM THE SYSTEM BEFORE REMOVING THE HIGH PRESSURE CUT OUT SWITCH.

REMOVAL

- (1) Disconnect wiring connector at the switch (Fig. 39).
- (2) Remove internal snap ring.
- (3) Pull switch out of compressor.

INSTALLATION

For installation, reverse the above procedures. Use a new O-Ring Seal.

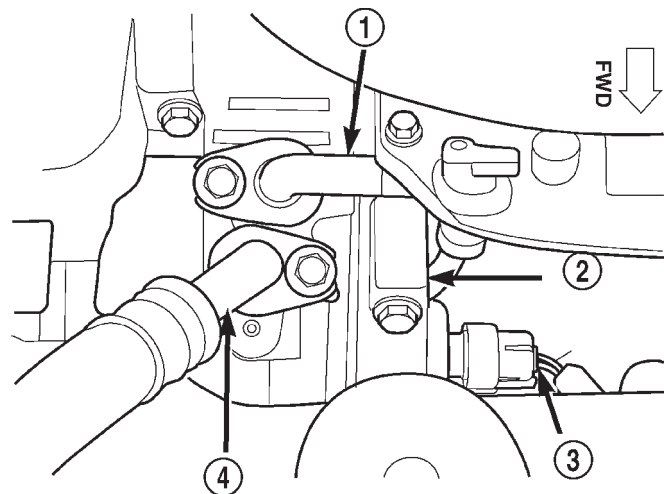

80bcea29

Fig. 39 High Pressure Cut Out Switch Location

- 1 - DISCHARGE LINE
- 2 - A/C COMPRESSOR
- 3 - HIGH PRESSURE CUT OUT SWITCH
- 4 - SUCTION LINE

HIGH PRESSURE RELIEF VALVE

WARNING: AVOID BREATHING A/C REFRIGERANT AND LUBRICANT VAPOR OR MIST. EXPOSURE MAY IRRITATE EYES, NOSE AND THROAT. USE ONLY APPROVED SERVICE EQUIPMENT MEETING SAE REQUIREMENTS TO DISCHARGE R-134a SYSTEM. IF ACCIDENTAL SYSTEM DISCHARGE OCCURS, VENTILATE WORK AREA BEFORE RESUMING SERVICE.

R-134a SERVICE EQUIPMENT OR VEHICLE A/C SYSTEM SHOULD NOT BE PRESSURE TESTED OR LEAK TESTED WITH COMPRESSED AIR. MIXTURE OF AIR and R-134a CAN BE COMBUSTIBLE AT ELEVATED PRESSURES. THESE MIXTURES ARE POTENTIALLY DANGEROUS AND MAY RESULT IN FIRE OR EXPLOSION CAUSING INJURY OR PROPERTY DAMAGE.

REMOVAL

- (1) Using a R-134a refrigerant recovery machine, remove the refrigerant from A/C system.
- (2) Rotate the high pressure relief valve counter-clockwise and separate relief valve from the compressor (Fig. 39).

INSTALLATION

For installation, reverse the above procedures using a new O-Ring Seal. Evacuate and charge the refrigerant system.

LIQUID LINE

WARNING: THE REFRIGERATION SYSTEM MUST BE COMPLETELY EMPTY BEFORE PROCEEDING WITH THIS OPERATION.

REMOVAL

- (1) Using a R-134a refrigerant recovery machine, remove the refrigerant from A/C system.
- (2) Disconnect liquid line at drier.
- (3) Disconnect liquid line at condenser.

INSTALLATION

For installation, reverse the above procedures.

LOW PRESSURE CUT OFF SWITCH

WARNING: THE REFRIGERATION SYSTEM MUST BE COMPLETELY RECOVERED BEFORE PROCEEDING WITH THIS OPERATION. REFER TO REFRIGERANT RECOVERY SECTION.

REMOVAL

- (1) Disconnect the wire connector at the cut off switch.
- (2) Using a sender unit removal socket, remove the switch from the expansion valve (Fig. 40).

REMOVAL AND INSTALLATION (Continued)

INSTALLATION

NOTE: Verify the O-ring condition on the replacement switch.

For installation, reverse the above procedures. Evacuate and charge the system.

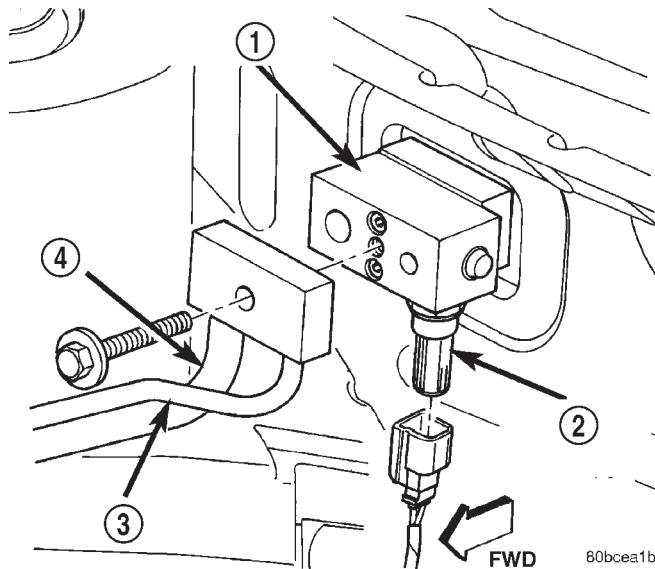

Fig. 40 Expansion Valve and Low Pressure Cut-Off Switch

- 1 - EXPANSION VALVE
- 2 - LOW PRESSURE CUTOFF SWITCH
- 3 - LIQUID LINE
- 4 - SUCTION LINE

MODE CONTROL CABLE

The Mode Control Cable can be removed and installed without having to remove the instrument panel from the vehicle.

REMOVAL

- (1) Remove instrument panel center stack bezel (Fig. 41).
- (2) Remove center air duct (Fig. 42).
- (3) Remove heater-A/C control head and disconnect cable (Fig. 43).
- (4) Disconnect cable at heater unit.
- (5) Remove cable from vehicle.

INSTALLATION

For installation, reverse the above procedures, adjust cable and test. Refer to Mode Control Cable Adjustment at the end of this section.

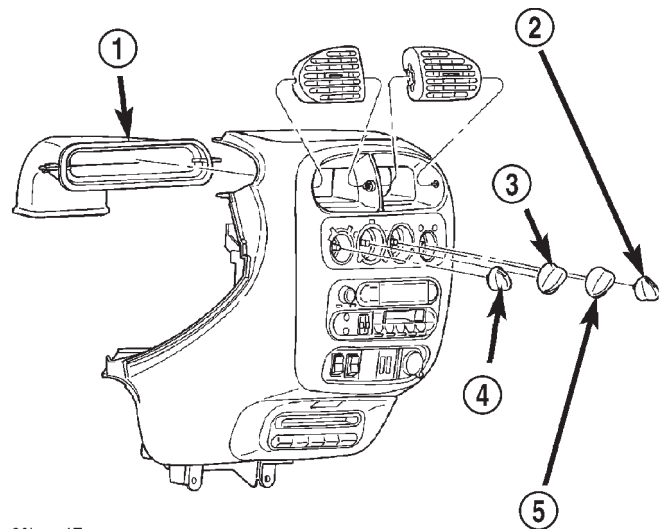

80bcea17

Fig. 41 Instrument Panel Center Bezel & Knobs

- 1 - INSTRUMENT PANEL CENTER AIR DUCT
- 2 - OUTSIDE AIR/RECIRC CONTROL KNOB
- 3 - MODE CONTROL KNOB
- 4 - BLOWER SPEED KNOB
- 5 - TEMPERATURE CONTROL KNOB

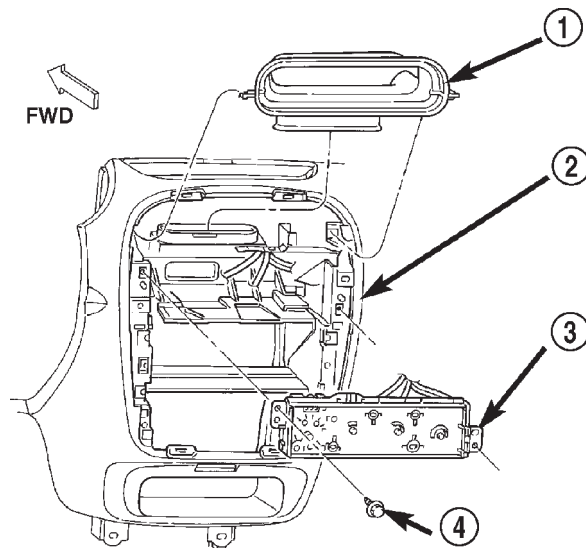

80bcea1f

Fig. 42 HVAC Center Air Duct & Control Head

- 1 - CENTER AIR DUCT
- 2 - INSTRUMENT PANEL
- 3 - HVAC CONTROL HEAD
- 4 - ATTACHING SCREWS

REMOVAL AND INSTALLATION (Continued)

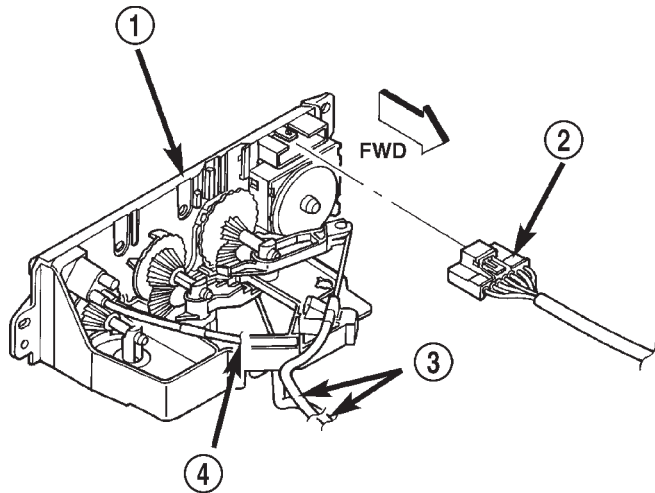

80bcea1e

Fig. 43 HVAC Control Head Cables

- 1 - HVAC CONTROL HEAD
- 2 - ELECTRICAL CONNECTOR
- 3 - CONTROL CABLES
- 4 - VACUUM HARNESS

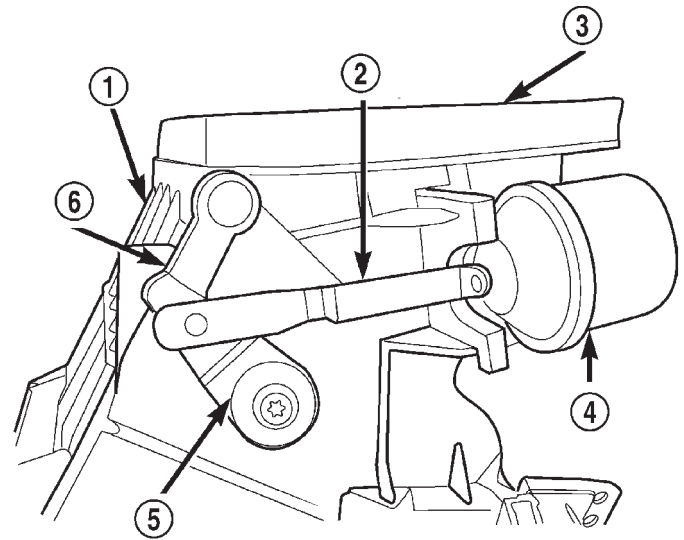

80bcea28

Fig. 44 Recirculation Door Actuator and Linkage

- 1 - OUTSIDE AIR/RECIRC DOOR HOUSING
- 2 - VACUUM ACTUATOR LINKAGE
- 3 - FOAM SEAL
- 4 - RECIRC DOOR VACUUM ACTUATOR
- 5 - DOOR LEVER
- 6 - DOOR LEVER

RECIRCULATION DOOR ACTUATOR

The recirculation door actuator is a vacuum controlled actuator used to control movement of the recirculation door in air conditioned equipped vehicles.

The instrument panel must be removed from the vehicle to gain access to the recirculation door actuator.

REMOVAL

- (1) Remove instrument panel from vehicle. Refer to Group 8E, Instrument Panel And Systems for removal procedures.
- (2) Disconnect vacuum line from actuator.
- (3) Disconnect actuator from recirculation door link (Fig. 44).
- (4) Release tension on latch, and slide recirculation door actuator off housing.

INSTALLATION

For installation, reverse the above procedures.

SUCTION LINE

WARNING: THE REFRIGERANT MUST BE RECOVERED BEFORE SERVICING ANY PART OF THE REFRIGERANT SYSTEMS.

REMOVAL

- (1) Using a R-134a refrigerant recovery machine, remove the refrigerant from A/C system.
- (2) Remove retaining bolt at expansion valve (Fig. 45).

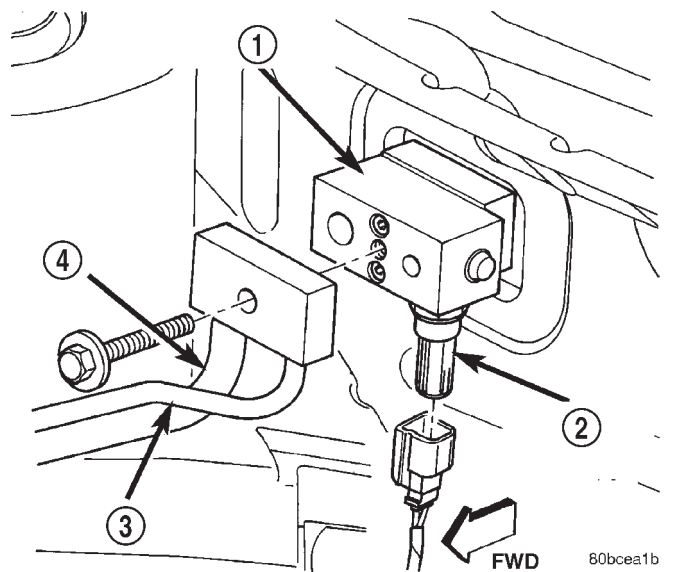

80bcea1b

Fig. 45 Expansion Valve Center Bolt

- 1 - EXPANSION VALVE
- 2 - LOW PRESSURE CUTOFF SWITCH
- 3 - LIQUID LINE
- 4 - SUCTION LINE

REMOVAL AND INSTALLATION (Continued)

- (3) Remove line at expansion valve.
- (4) Remove line at compressor (Fig. 46).

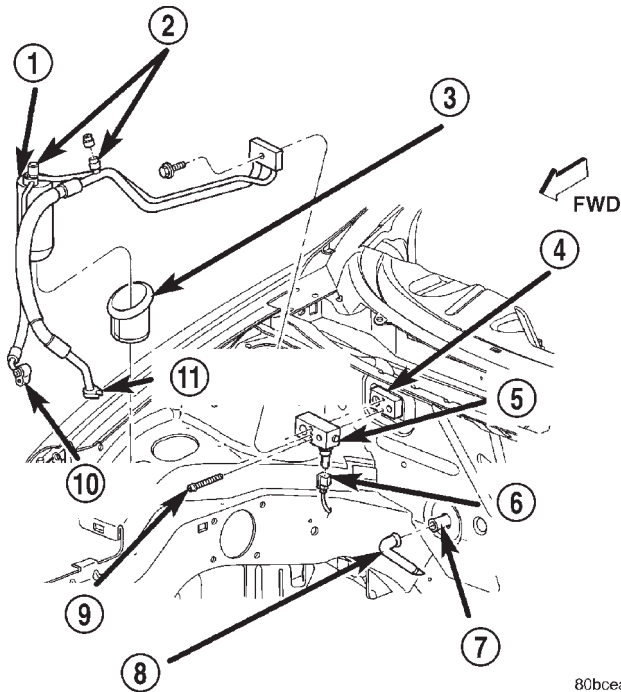

80bcea24

Fig. 46 A/C Compressor Suction Line

- 1 - FILTER DRIER
- 2 - SERVICE PORTS
- 3 - FILTER DRIER MOUNTING GROMMET
- 4 - EVAPORATOR LINE BLOCK
- 5 - EXPANSION VALVE
- 6 - LOW PRESSURE CUT OUT SWITCH CONNECTOR
- 7 - HVAC HOUSING DRAIN OUTLET
- 8 - CONDENSATE DRAIN TUBE
- 9 - EXPANSION VALVE SCREWS
- 10 - CONDENSER LIQUID LINE
- 11 - COMPRESSOR SUCTION LINE

INSTALLATION

For installation, reverse the above procedures.

TEMPERATURE CONTROL CABLE

The Control Cable can be removed and installed without having to remove the instrument panel from the vehicle.

REMOVAL

- (1) Remove instrument panel center stack bezel (Fig. 41).
- (2) Remove heater-A/C control head (Fig. 42).
- (3) Remove center air duct.
- (4) Disconnect cable at control panel. Remove control from instrument panel.
- (5) Disconnect cable at heater unit (Fig. 47).
- (6) Remove cable from vehicle.

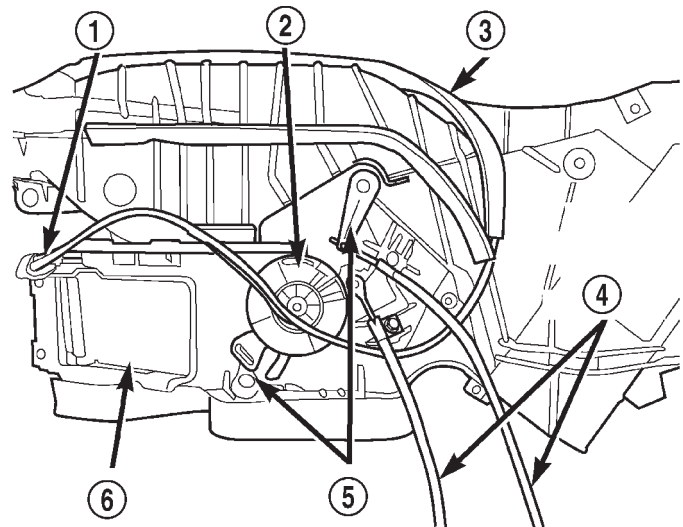

80bcea27

Fig. 47 HVAC Housing Cables

- 1 - VACUUM HARNESS
- 2 - DOOR CAM
- 3 - HVAC UPPER HOUSING
- 4 - HVAC CONTROL HEADS CABLES
- 5 - MODE DOOR LEVERS
- 6 - DEFROSTER DUCT OUTLET

INSTALLATION

For installation, reverse the above procedures, adjust cable and test. See Temperature Control Cable Adjustment in this section.

UNIT HOUSING

The instrument panel must be removed in order to remove the Unit Housing. Refer to group 8E Instrument Panel and Systems for detailed procedure.

WARNING: THE R-134a REFRIGERANT SYSTEM MUST BE RECOVERED BEFORE SERVICING ANY PART OF THE REFRIGERANT SYSTEM.

REMOVAL

- (1) Using a refrigerant recovery machine, remove the refrigerant from the A/C system, if equipped.
- (2) Remove instrument panel from vehicle. Refer to group 8E Instrument Panel and Systems for detailed procedure.
- (3) Drain cooling system and remove heater hoses at the dash panel. Place plugs in the heater core outlets to prevent coolant spillage during unit housing removal.
- (4) Unfasten coolant recovery container and set aside.
- (5) Remove suction line at expansion valve. Cap open refrigerant lines to prevent moisture and/or dirt from entering.

REMOVAL AND INSTALLATION (Continued)

(6) Remove expansion valve from evaporator, and cap fittings.

(7) Remove rubber drain tube extension from condensation drain tube.

(8) Disconnect the vacuum harness at the power brake booster (Fig. 48).

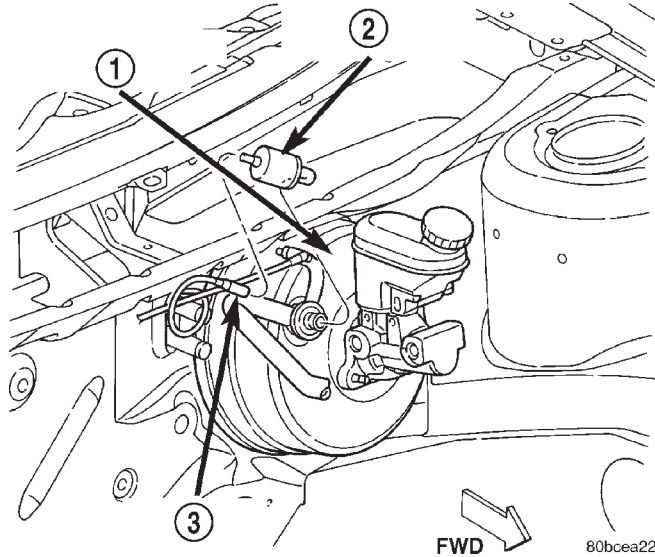

Fig. 48 HVAC Vacuum Harness

- 1 - BRAKE POWER BOOSTER
- 2 - A/C VACUUM CHECK VALVE
- 3 - VACUUM HARNESS

(9) Unsnap and remove the defroster duct (Fig. 49).

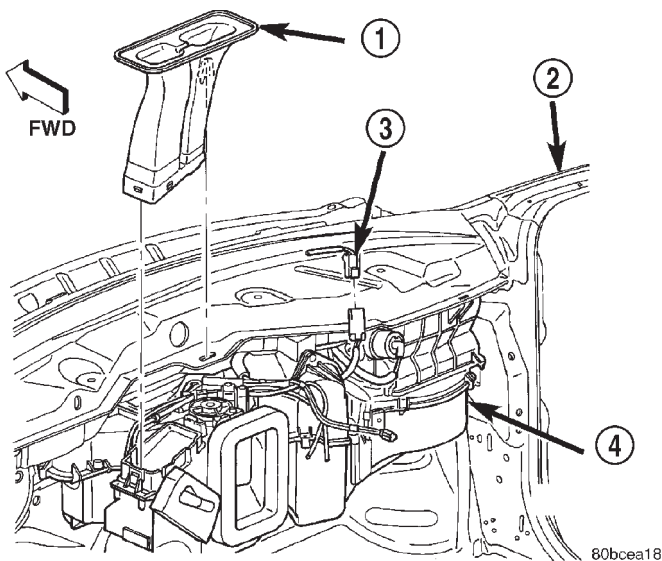

Fig. 49 HVAC Housing Defroster Duct

- 1 - DEFROSTER DUCT
- 2 - BODY
- 3 - ELECTRICAL CONNECTOR
- 4 - HVAC HOUSING

(10) Remove three retaining nuts located in the engine compartment, on the dash panel (Fig. 50).

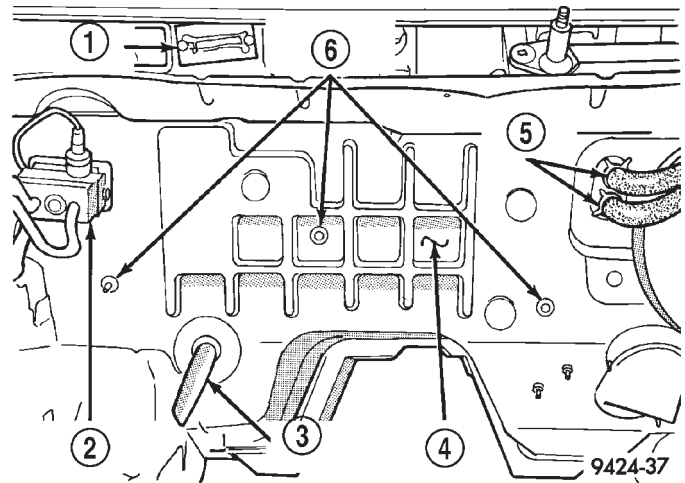

Fig. 50 Dash Panel Retaining Studs

- 1 - BLOWER RESISTOR
- 2 - EXPANSION VALVE
- 3 - DRAIN TUBE
- 4 - DASH PANEL
- 5 - HEATER HOSES
- 6 - RETAINING STUDS

(11) Remove the right side retaining screw (Fig. 51).

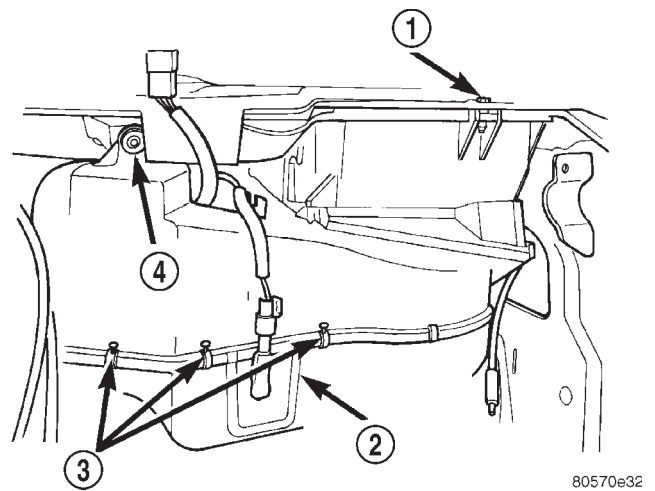

Fig. 51 Housing Screws

- 1 - RIGHT SIDE RETAINING SCREW
- 2 - EVAPORATOR PROBE GROMMET
- 3 - SCREW BOSSES
- 4 - DASH PANEL STUD AND NUT

(12) Remove remaining nut located on dash panel stud.

(13) Disconnect the wiring connectors.

(14) Remove assembly from the vehicle.

REMOVAL AND INSTALLATION (Continued)

INSTALLATION

For installation, reverse the above procedures.

DISASSEMBLY AND ASSEMBLY

HEATER-A/C HOUSING

Use this procedure if any or all of the following items require service:

- Heater core
- Evaporator
- HVAC housing

The HVAC housing must be removed from the vehicle before beginning with this procedure. Refer to Unit Housing in this section for removal procedure.

DISASSEMBLY

(1) Separate the air distribution outlet foam seals at the case parting line (Fig. 52).

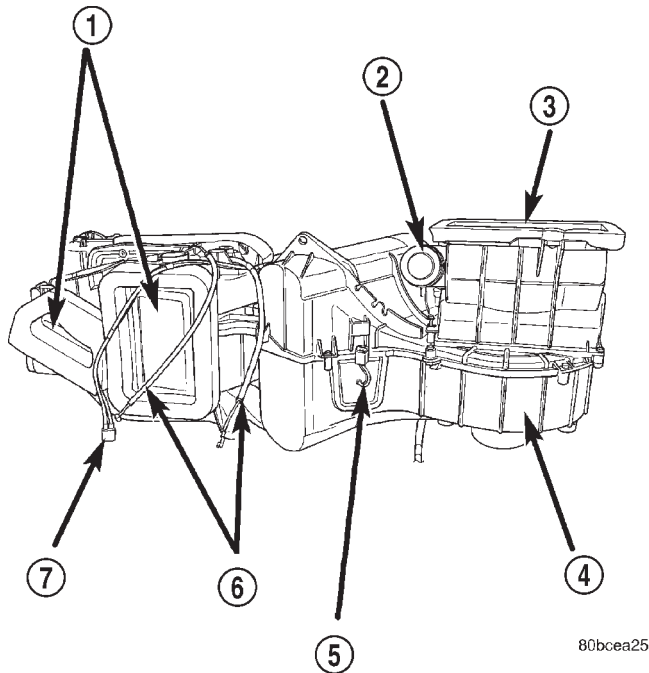

Fig. 52 HVAC Housing Air Distribution Foam Seals

- 1 - AIR DISTRIBUTION
- 2 - RECIRCULATION DOOR VACUUM ACTUATOR
- 3 - AIR INLET
- 4 - BLOWER MOTOR
- 5 - EVAPORATOR PROBE CONNECTOR
- 6 - CONTROL CABLES
- 7 - VACUUM HARNESS

(2) Remove the evaporator lines foam seal, and heater core tubes foam seal from the unit (Fig. 53).

(3) Remove the retaining clips and screws that hold the upper and lower housings together.

(4) Separate the two halves of the housing.

(5) Lift the heater core/evaporator out of the case.

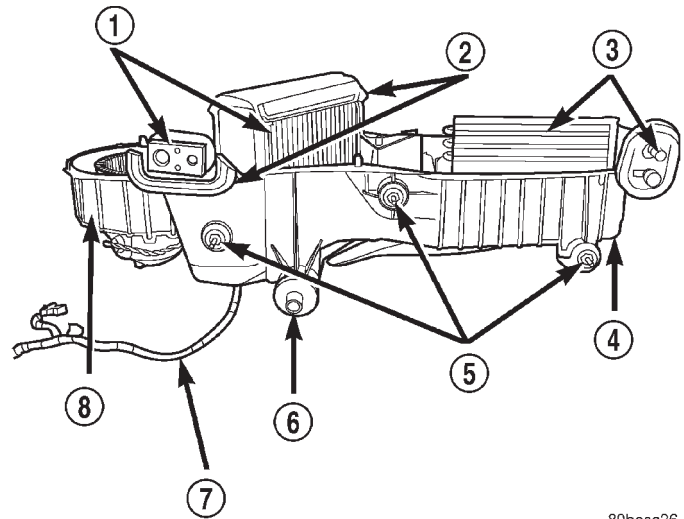

80bcea26

Fig. 53 HVAC Housing Evaporator Connection and Heater Core Tube Seals

- 1 - EVAPORATOR AND CONNECTION
- 2 - FOAM SEALS
- 3 - HEATER CORE AND TUBES
- 4 - HVAC HOUSING LOWER CASE
- 5 - HOUSING MOUNTING STUDS
- 6 - HOUSING DRAIN
- 7 - WIRING
- 8 - BLOWER MOTOR AND WHEEL

ASSEMBLY

To reassemble, reverse the above procedures.

ADJUSTMENTS

MODE CONTROL CABLE

(1) Engage cable to actuator arm lever on mode door and attach to housing (Fig. 47).

(2) Attach other end of cable to instrument panel control (Fig. 43).

(3) Turn the mode knob completely counterclockwise.

(4) While holding the knob in the counterclockwise position, pull on the gray casing of the mode cable. This will take up any free play in the cable and index the mode door to the mode knob.

(5) Then snap the cable hold down clip into position.

TEMPERATURE CONTROL CABLE

(1) Engage cable to actuator arm on temperature door and attach to housing (Fig. 47).

(2) Attach other end of cable to instrument panel control (Fig. 43).

(3) Turn the temperature knob completely counterclockwise.

ADJUSTMENTS (Continued)

(4) While holding the knob in the counterclockwise position, pull on the gray casing of the temperature cable. This will take up any free play in the cable and index the temperature door to the temperature knob.

- (5) Then snap the cable hold down clip into position.
- (6) Remount control.

