



LD22 GRILL

Important Installation Information

The installer must ensure that installation of the unit(s) is in conformity with regulations in force at the time. For the UK, particular attention requires to be paid to:-

BS7671 IEE Wiring Regulations

Electricity at Work Regulations

Health and Safety at Work Act

Fire Precautions Act

The unit has been CE-marked on the basis of compliance with the Low Voltage and EMC Directives for the voltage stated on the data plate.

WARNING: THIS APPLIANCE MUST BE EARTHED!

Preventive Maintenance Contract

In order to obtain maximum performance from the equipment, we would recommend that a maintenance contract be arranged with **Serviceline**. Visits may then be made at agreed intervals to carry out adjustments and repairs. A quotation for this service will be provided upon request. Contact **Serviceline** as detailed below:-

Tel: 01438 363 000 Fax: 01438 369 900



WEEE Directive Registration No. WEE/DC0059TT/PRO

At end of unit life, dispose of appliance and any replacement parts in a safe manner, via a licenced waste handler.

Units are designed to be dismantled easily and recycling of all material is encouraged whenever practicable.

Falcon Foodservice Equipment

Wallace View, Hillfoots Road, Stirling. FK9 5PY

Tel: 01786 455 200 Fax: 01786 469 454

e-mail: info@falconfoodservice.com

T100322 Ref. 3

Technical Installation Information Table

Note * 13A Fuse Rating: The unit must be protected by a 13 amp fuse if a 13 amp plug is used. If another type of plug is used, a 15A fuse requires to be used in the plug, adaptor or distribution board.

Dimensions 600m (W) x 350mm (D) x 285mm (H)

Vertical Clearance - 900mm

Side & Rear Clearance - 150mm **Weight** - 18.5kg

Power Rating - 2.65kW **Fuse** - 13 amp

SECTION 1 - SITING

PRO-LITE models have been designed in a modular form which consists of base, counter and free-standing units.

Information which relates to individual models is listed above.

Free-standing and base models should be installed upon a firm, level surface and adjustable feet are provided for levelling purposes.

Counter units must be positioned upon a table, counter or similar surface.

Vertical and horizontal clearances required from the top and sides of a particular unit to any overlying combustible surface (ie wall, partition, etc) are listed above. Relevant fire regulations must be complied with.

Grill Mounting

The grill can be mounted directly upon a table, counter or similar surface and must be secured accordingly. It may also be secured upon a leg stand which requires to be fixed to the surface using the brackets supplied.

WARNING: Never mount a grill directly upon a combustible surface without a leg stand.

The stand assembly is supplied as an optional extra and secured to the unit base with the fixings provided (see Figure 1).

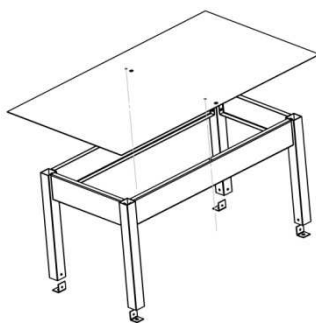

Secure through stand base to grill base

Figure 1a

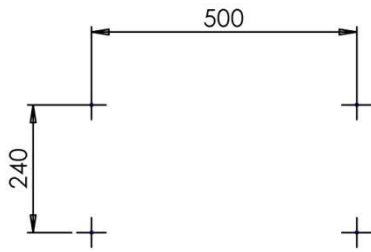

Leg bracket fixing centres

Figure 1b

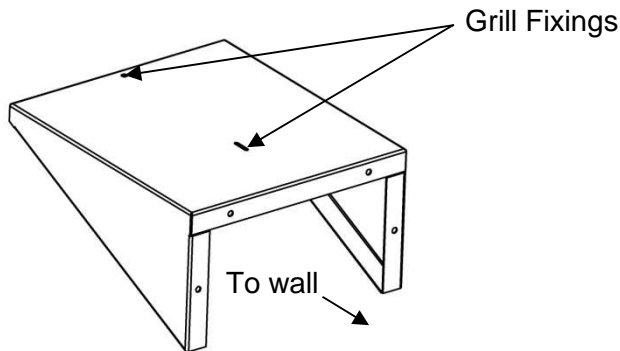

The leg locating brackets then require to be secured to the worktop surface using the appropriate fixings. The fixing centres are indicated in Figure 1b. The brackets should then be rotated to ensure that the location holes correspond with the side fixing hole in each leg. Locate the brackets up inside the legs and insert one fixing in each to secure the assembly.

A further option is to position the grill upon an optional shelf bracket (see Figure 2). The installer should ensure that the wall upon which the shelf is to be mounted can support the weight. This requires to be plugged to accommodate No.8 wood screws or equivalent of at least 50mm in length.

To fix, hold the shelf horizontally in the desired position and mark the fixing holes through the flanges prior to drilling. Insert the plugs and secure the bracket firmly in position. The grill should then be placed upon the bracket and located using the fixings provided.

Either option requires an installation clearance of 50mm at the sides and rear to be observed.

SECTION 2 -

ELECTRICAL SUPPLY AND CONNECTION

Electrical ratings are as stated on the unit data plate. The listing in Table 1 is based on standard UK specification at 230V. Wiring must be executed in accordance with the regulations listed in this booklet.

WARNING: Each individual appliance must be earthed!

After completion of installation, the method of operation should be demonstrated to the kitchen staff. The isolating switch location, for use in an emergency or during cleaning should also be pointed out.

This model is designed to be connected to a single phase AC supply using the 2 metre mains lead fitted as standard.

Wires are coloured in accordance with the following code and should be connected to the plug as follows:

EARTH to terminal marked E

NEUTRAL to terminal marked N

LIVE to terminal marked L.

Units which receive power from a plug, adaptor or distribution board must be individually protected by a fuse with an appropriate rating.

Any replacement supply cable must be 1.5mm², cord code designation 245 IEC 57 (CENELEC H05 RN-F).

For internal connection, outer sheathing must be stripped 140mm from the cable end. The live and neutral conductors must be trimmed so that the Earth conductor is longer by 50mm. Pass inlet cable through the rear panel cord grip and ensure that the cable is routed without leaving excessive free length inside the appliance.

SECTION 3 - USING AND CLEANING

IMPORTANT: GENERAL NOTES ON CLEANING

Disconnect unit from electricity supply prior to cleaning

Never use a coarse abrasive to clean exterior panels. A soft cloth with a warm water and detergent solution is sufficient.

Never attempt to steam clean a unit or hose it down with a jet of water.

LD22 GRILL

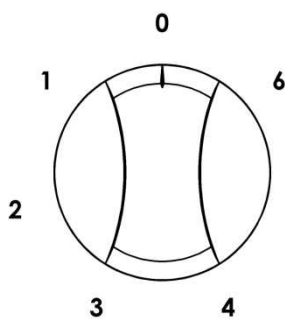

Supplied with toast grid and removable drip tray as standard. A cast aluminium brander is available as an optional extra.

Grill Control Switch

Element is controlled by turning the energy regulator clockwise to enable infinite variable heat settings between 1 and 6.

Using the Grill

Drip tray must be in position at all times when in operation. The grid may be used in any of 5 runner positions with the top position recommended for best results when toasting bread. Maximum heat setting is required and the full grid surface may be covered.

For best results when cooking meat, a brander pre-heat time of 30 minutes is recommended. Any runner position may be used and the brander can be tilted to suit individual requirements.

Cleaning a Grill

Clean when cool using a detergent/water solution and dry thoroughly. Use a soap-filled pad to remove stubborn stains. Take care when using these on stainless steel. Never use harsh abrasives on such a surface. Ensure excess water does not run into the element or terminal compartment. The aluminium brander should be left under full heat until the debris has carbonised. The debris can then be removed with a wire brush.

LD22 GRILL SERVICE ACCESS

Removal of Control Panel

Undo fixing on RH underside of control panel. Lower panel to clear top edge catch.

FUNCTIONAL COMPONENTS

Temperature Controls

Remove control panel.

Remove electrical connections, noting the positions.

Remove control knob.

Undo fixings which secure control to panel and remove.

Replace in reverse order.

Neon Indicator

Remove control panel.

Remove electrical connections.

Undo retaining nut to remove neon.

Replace in reverse order.

Terminal Block/Cable Grip

Remove control panel.

Remove electrical connections at terminal block, noting the positions.

Undo fixings which secure the block to the unit and remove.

Replace in reverse order.

Mains Power Cable

Remove control panel.

Undo mains lead cable and grip at unit rear.

Undo electrical connections at terminal block and remove cable.

Replace in reverse order. Ensure cable is fed through securing clamp and pulled taut before tightening the clamp.

Element

Remove control panel.

Undo element electrical connections, noting positions.

Undo element panel fixings and remove element.

Replace in reverse order.

PROLITE GRILL SHORT SPARES

737630010 Element

737630011 Energy Regulator

735110050 Control Knob

730962010 Mains Neon

735011110 Supply Cable

LD22 Wiring Diagram

