



Agilent 1260 Infinity Micro Degasser

User Manual



Agilent Technologies

Notices

© Agilent Technologies, Inc. 2006, 2007-2008, 2010

No part of this manual may be reproduced in any form or by any means (including electronic storage and retrieval or translation into a foreign language) without prior agreement and written consent from Agilent Technologies, Inc. as governed by United States and international copyright laws.

Manual Part Number

G1379-90013

Edition

06/10

Printed in Germany

Agilent Technologies
Hewlett-Packard-Strasse 8
76337 Waldbronn

This product may be used as a component of an in vitro diagnostic system if the system is registered with the appropriate authorities and complies with the relevant regulations. Otherwise, it is intended only for general laboratory use.

Warranty

The material contained in this document is provided “as is,” and is subject to being changed, without notice, in future editions. Further, to the maximum extent permitted by applicable law, Agilent disclaims all warranties, either express or implied, with regard to this manual and any information contained herein, including but not limited to the implied warranties of merchantability and fitness for a particular purpose. Agilent shall not be liable for errors or for incidental or consequential damages in connection with the furnishing, use, or performance of this document or of any information contained herein. Should Agilent and the user have a separate written agreement with warranty terms covering the material in this document that conflict with these terms, the warranty terms in the separate agreement shall control.

Technology Licenses

The hardware and/or software described in this document are furnished under a license and may be used or copied only in accordance with the terms of such license.

Restricted Rights Legend

If software is for use in the performance of a U.S. Government prime contract or subcontract, Software is delivered and licensed as “Commercial computer software” as defined in DFAR 252.227-7014 (June 1995), or as a “commercial item” as defined in FAR 2.101(a) or as “Restricted computer software” as defined in FAR 52.227-19 (June 1987) or any equivalent agency regulation or contract clause. Use, duplication or disclosure of Software is subject to Agilent Technologies’ standard commercial license terms, and non-DOD Departments and Agencies of the U.S. Government will

receive no greater than Restricted Rights as defined in FAR 52.227-19(c)(1-2) (June 1987). U.S. Government users will receive no greater than Limited Rights as defined in FAR 52.227-14 (June 1987) or DFAR 252.227-7015 (b)(2) (November 1995), as applicable in any technical data.

Safety Notices

CAUTION

A **CAUTION** notice denotes a hazard. It calls attention to an operating procedure, practice, or the like that, if not correctly performed or adhered to, could result in damage to the product or loss of important data. Do not proceed beyond a **CAUTION** notice until the indicated conditions are fully understood and met.

WARNING

A **WARNING** notice denotes a hazard. It calls attention to an operating procedure, practice, or the like that, if not correctly performed or adhered to, could result in personal injury or death. Do not proceed beyond a **WARNING** notice until the indicated conditions are fully understood and met.

Contents

1 Introduction	5
Introduction to the Micro Vacuum Degasser	6
2 Site Requirements and Specifications	7
Site Requirements	8
Physical Specifications	11
Performance Specifications	12
3 Installing the Micro Vacuum Degasser	13
Unpacking the Micro Vacuum Degasser	14
Optimizing the Stack Configuration	16
Installing the Micro Vacuum Degasser	19
Flow Connections to the Micro Vacuum Degasser	21
Operational Hints for the Micro Vacuum Degasser	24
Transporting the Micro Vacuum Degasser	27
4 Using the Micro Vacuum Degasser	29
When to Use a Micro Vacuum Degasser?	30
Solvent Information	32
5 Optimizing Performance	35
Increasing the Degasser Performance and Degassing Level	36
6 Troubleshooting and Diagnostics	37
Overview of the Degasser's Indicators	38
Status Indicators	39
Hardware Symptoms	41
7 Maintenance	45
Introduction to Maintenance and Repair	46

Contents

8	Parts and Materials for Maintenance	57
	Cover Parts cover	58
	Sheet Metal Kit	59
	Power and Status Light Pipes	60
	Accessory Kit	61
9	Cable overview	63
	Overview	64
	Remote Cable	66
10	Appendix	69
	General Safety Information	70
	The Waste Electrical and Electronic Equipment "WEEE) Directive (2002/96/EC)	73
	Radio Interference	74
	Sound Emission	75
	Agilent Technologies on Internet	76

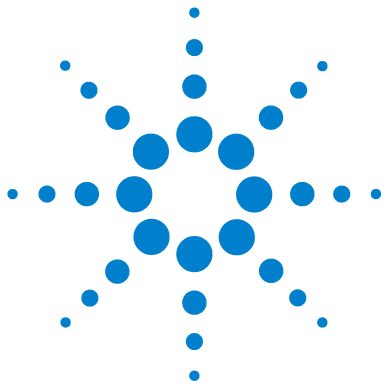

1 Introduction

Introduction to the Micro Vacuum Degasser 6



Introduction to the Micro Vacuum Degasser

The Agilent 1260 Infinity micro vacuum degasser, model G1379B, comprises a 4-channel vacuum container, including 4 micro structured membranes, and a vacuum pump. When the micro vacuum degasser is switched on, the control circuit turns on the vacuum pump, which is operated with constant speed and voltage generates a partial vacuum in the vacuum container. The pressure is measured by a pressure sensor. The micro vacuum degasser maintains the partial vacuum with the help of a controlled leak in the degasser's proportional valve and by varying size of the controlled leak within the proportional valve, depending on the signal from the pressure sensor.

The LC pump draws the solvents from their bottles through the special plastic membranes of the vacuum container. As the solvents pass through the vacuum chambers any dissolved gas in the solvents permeates through the membranes into the vacuum container. The solvents will be almost completely degassed when leaving the outlets of the micro vacuum degasser.

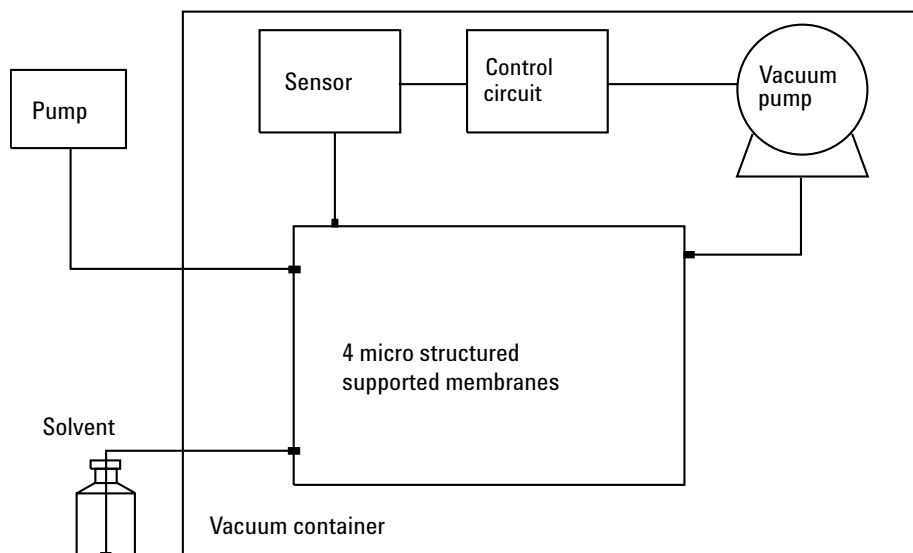

Figure 1 Overview (only one of the four solvent channels is shown)



2 Site Requirements and Specifications

Site Requirements	8
Physical Specifications	11
Performance Specifications	12



Site Requirements

A suitable environment is important to ensure optimal performance of the instrument.

Power Considerations

The module power supply has wide ranging capability. It accepts any line voltage in the range described in [Table 1](#) on page 11. Consequently there is no voltage selector in the rear of the module. There are also no externally accessible fuses, because automatic electronic fuses are implemented in the power supply.

WARNING

Hazard of electrical shock or damage of your instrumentation can result, if the devices are connected to a line voltage higher than specified.

→ Connect your instrument to the specified line voltage only.

WARNING

Module is partially energized when switched off, as long as the power cord is plugged in.

Repair work at the module can lead to personal injuries, e.g. electrical shock, when the cover is opened and the module is connected to power.

→ Always unplug the power cable before opening the cover.

→ Do not connect the power cable to the instrument while the covers are removed.

CAUTION

Unaccessible power plug.

In case of emergency it must be possible to disconnect the instrument from the power line at any time.

- Make sure the power connector of the instrument can be easily reached and unplugged.
 - Provide sufficient space behind the power socket of the instrument to unplug the cable.
-

Power Cords

Different power cords are offered as options with the module. The female end of all power cords is identical. It plugs into the power-input socket at the rear. The male end of each power cord is different and designed to match the wall socket of a particular country or region.

WARNING

Absence of ground connection or use of unspecified power cord

The absence of ground connection or the use of unspecified power cord can lead to electric shock or short circuit.

- Never operate your instrumentation from a power outlet that has no ground connection.
 - Never use a power cord other than the Agilent Technologies power cord designed for your region.
-

WARNING

Use of unsupplied cables

Using cables not supplied by Agilent Technologies can lead to damage of the electronic components or personal injury.

- Never use cables other than the ones supplied by Agilent Technologies to ensure proper functionality and compliance with safety or EMC regulations.
-

2 Site Requirements and Specifications

Site Requirements

WARNING

Unintended use of supplied power cords

Using power cords for unintended purposes can lead to personal injury or damage of electronic equipment.

- Never use the power cords that Agilent Technologies supplies with this instrument for any other equipment.
-

Bench Space

The module dimensions and weight (see [Table 1](#) on page 11) allow you to place the module on almost any desk or laboratory bench. It needs an additional 2.5 cm (1.0 inches) of space on either side and approximately 8 cm (3.1 inches) in the rear for air circulation and electric connections.

If the bench should carry an Agilent system, make sure that the bench is designed to bear the weight of all modules.

The module should be operated in a horizontal position.

Condensation

CAUTION

Condensation within the module

Condensation will damage the system electronics.

- Do not store, ship or use your module under conditions where temperature fluctuations could cause condensation within the module.
 - If your module was shipped in cold weather, leave it in its box and allow it to warm slowly to room temperature to avoid condensation.
-

Physical Specifications

Table 1 Physical Specifications

Type	Specification	Comments
Weight	7 kg (16 lbs)	
Dimensions (height × width × depth)	345 x 435 x 80 mm (13.5 x 17 x 3.1 inches)	
Line voltage	100 – 240 VAC, ± 10%	Wide-ranging capability
Line frequency	50 or 60 Hz, ± 5%	
Power consumption	30 VA / 30 W / 102 BTU	Maximum
Ambient operating temperature	0 – 45 °C (32 – 113 °F) 1	
Ambient non-operating temperature	-40–70 °C (-4–158 °F)	
Humidity	< 95%, at 25–40 °C (77–104 °F)	Non-condensing
Operating Altitude	Up to 2000 m (6562 ft)	
Non-operating altitude	Up to 4600 m (15091 ft)	For storing the module
Safety standards: IEC, CSA, UL	Installation Category II, Pollution Degree 2	For indoor use only.

¹ This temperature range represents the technical specifications for this instrument. The mentioned temperatures may not be suitable for all applications and all types of solvents.

Performance Specifications

Table 2 Performance Specifications Agilent 1260 Infinity Vacuum Degasser

Type	Specification
Maximum flow rate	0 - 5 ml/min per channel
Number of channels	4
Internal volume per channel	Typically 1 ml per channel
Materials in contact with solvent	PTFE, FEP,PEEK
pH range	1 – 14
RS-232 output	For diagnostic purposes

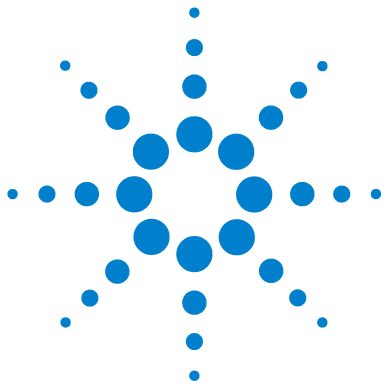

3

Installing the Micro Vacuum Degasser

Unpacking the Micro Vacuum Degasser	14
Accessory Kit Contents	15
Optimizing the Stack Configuration	16
Installing the Micro Vacuum Degasser	19
Flow Connections to the Micro Vacuum Degasser	21
Operational Hints for the Micro Vacuum Degasser	24
General Priming Instructions	24
Priming the Degasser	25
Priming with a Syringe (only recommended if priming with the pump fails)	26
Transporting the Micro Vacuum Degasser	27



Unpacking the Micro Vacuum Degasser

Damaged Packaging

Upon receipt of your micro vacuum degasser, inspect the shipping containers for any signs of damage. If the containers or cushioning material are damaged, save them until the contents have been checked for completeness and the micro vacuum degasser has been mechanically and electrically checked. If the shipping container or cushioning material is damaged, notify the carrier and save the shipping material for the carriers inspection.

Delivery Checklist

Ensure all parts and materials have been delivered with the micro vacuum degasser. The delivery checklist is shown below. To aid in parts identification, please see [“Parts and Materials for Maintenance”](#) on page 57. Please report missing or damaged parts to your local Agilent Technologies Sales and Service Office.

Table 3 Vacuum Degasser Delivery Checklist

Description	Quantity
Vacuum Degasser	1
Power Cable	1
Service Manual	1
Accessory Kit (“Accessory Kit Contents” on page 15)	1

Accessory Kit Contents

Item	p/n	Description
1	G1379-68706	Connecting tubing (to connect to channels in series for increased performance) 2x
2	G1322-67300	Kit of 4 solvent tubes for connection degasser to MCGV (Quaternary Pump) including labels
3	5062-2463	Tubing Flex 5 m
4	0100-1710	Mounting Tool for Tubing Connections

Optimizing the Stack Configuration

If your micro vacuum degasser is part of a system, you can ensure optimum performance by limiting the configuration of the system stack to the following configuration. This configuration optimizes the system flow path, ensuring minimum delay volume (from point of solvent mixing to head of column) and dead volume (from point of injection to detector outlet).

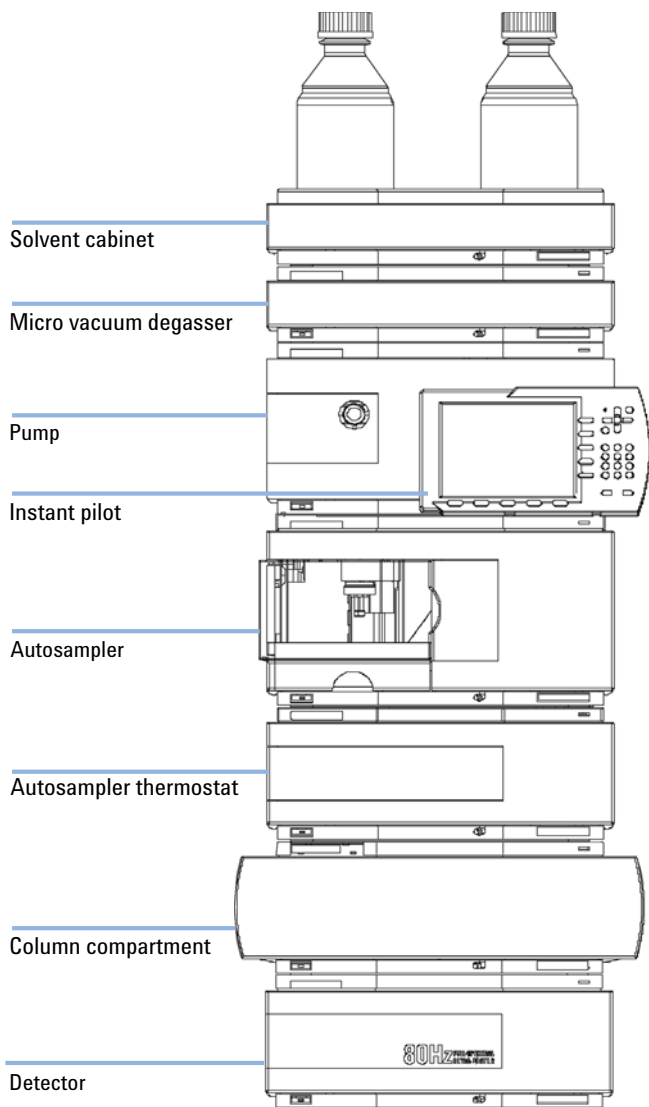

Figure 2 Recommended Stack Configuration (Front View)

3 Installing the Micro Vacuum Degasser Optimizing the Stack Configuration

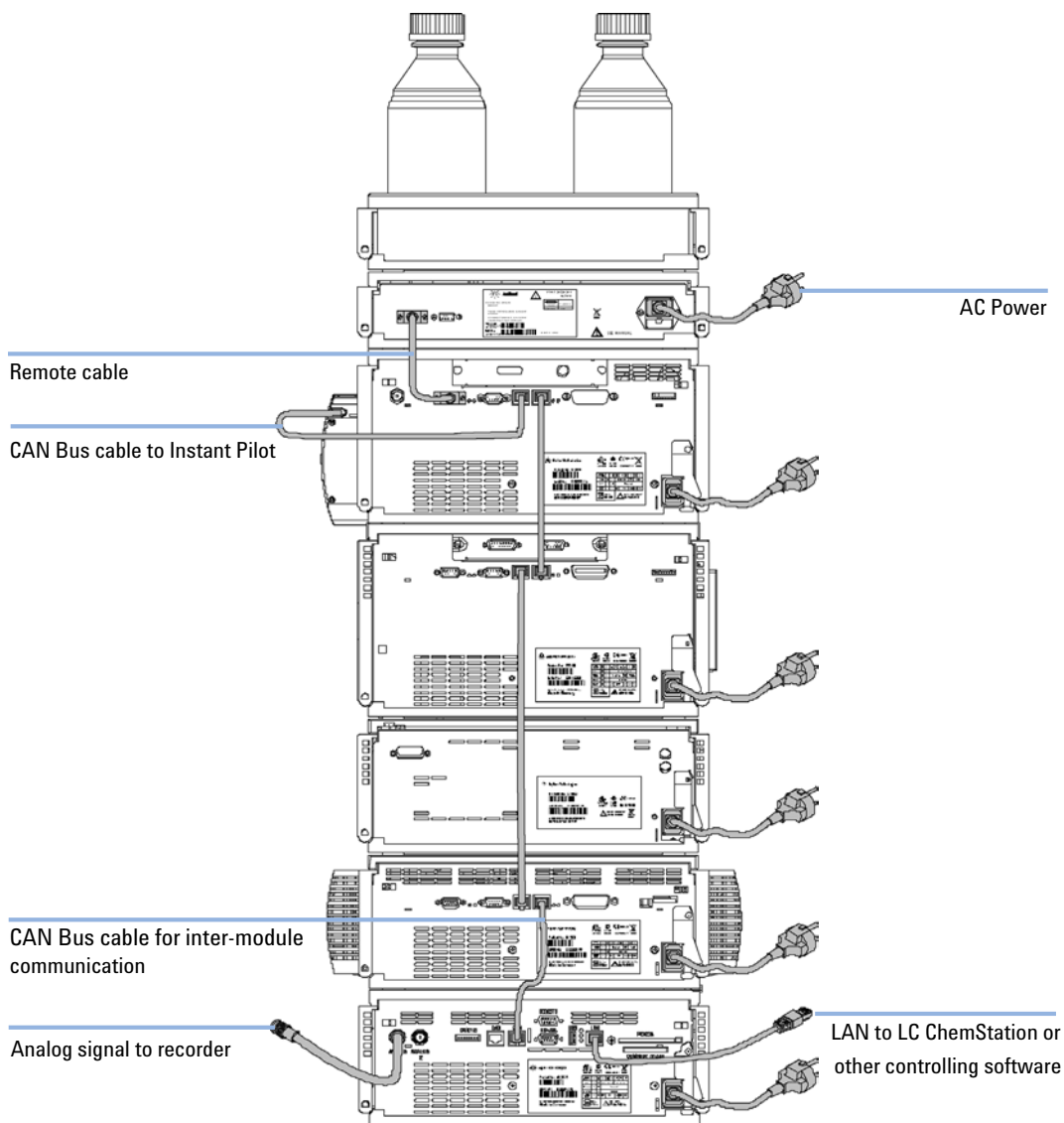

Figure 3 Recommended Stack Configuration (Rear View)

Installing the Micro Vacuum Degasser

Parts required	Description Power cord Interface cable as ordered, see “Overview” on page 64
Hardware required	Micro degasser
Preparations	Locate bench space Provide power connections Unpack the vacuum degasser module

WARNING

Abnormal conditions

In case of abnormal conditions during operation, the instrument must be disconnected from line.

→ To disconnect the instrument from line, unplug the power cord.

CAUTION

"Defective on arrival" problems

If there are signs of damage, please do not attempt to install the module. Inspection by Agilent is required to evaluate if the instrument is in good condition or damaged.

→ Notify your Agilent sales and service office about the damage.

→ An Agilent service representative will inspect the instrument at your site and initiate appropriate actions.

- 1 Place the micro vacuum degasser on the bench.
- 2 Ensure the power switch on the front of the micro vacuum degasser is OFF (switch stands out).
- 3 Connect the remote cable to the power connector at the rear of the micro vacuum degasser.
- 4 Option: Connect the interface cable to the micro vacuum degasser. The remote cable is a one way connection to send a not-ready signal from the

3 Installing the Micro Vacuum Degasser

Installing the Micro Vacuum Degasser

degasser to the other modules to shut down the whole system after an error condition of the degasser.

NOTE

In an Agilent 1260 Infinity stack, the individual modules are connected through a CAN cable. The Agilent 1260 Infinity micro vacuum degasser is an exception. The micro vacuum degasser can be connected via the APG remote cable to the other modules of the stack. An Agilent 1260 Infinity Instant Pilot can be connected to the CAN bus at any of the modules in the system except for the degasser. The control software can be connected to the system through one GPIB or LAN cable (via LAN-Card) at any of the modules (except for the degasser), preferably at the detector.

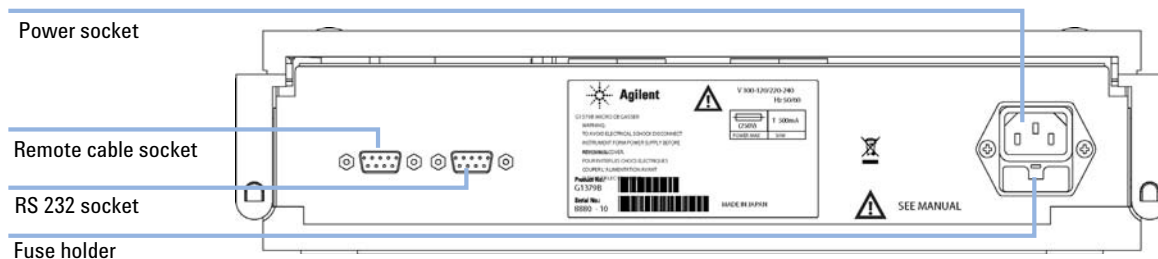

Figure 4 Rear of the Micro Vacuum Degasser

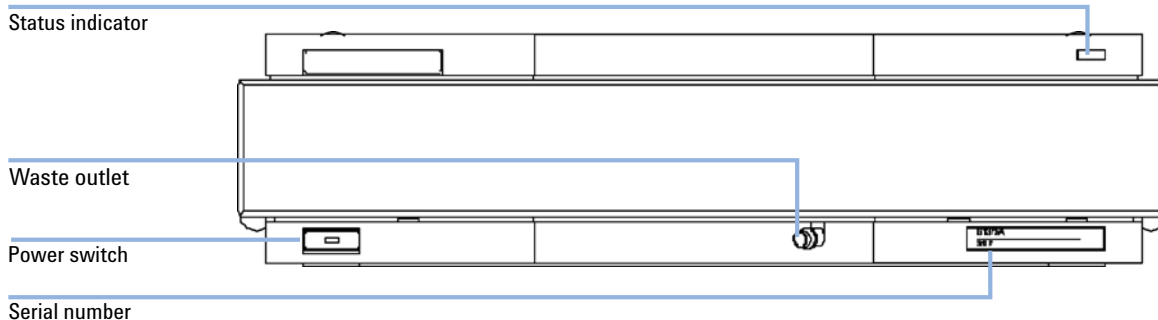

Figure 5 Front of the Micro Vacuum Degasser

5 Press in the power switch to turn ON the micro vacuum degasser.

NOTE

The power switch stays pressed in and a green indicator lamp in the power switch is ON when the micro vacuum degasser is turned ON. When the line power switch stands out and the green light is OFF, the micro vacuum degasser is turned OFF.

Flow Connections to the Micro Vacuum Degasser

Parts required	Description Solvent cabinet including solvent bottles (filled with solvent) and bottle head assemblies Solvent outlet tubes Syringe with adapter
Hardware required	Micro degasser
Preparations	Install the micro vacuum degasser

WARNING

When opening capillary or tube fittings solvents may leak out.

The handling of toxic and hazardous solvents and reagents can hold health risks.

→ Please observe appropriate safety procedures (for example, goggles, safety gloves and protective clothing) as described in the material handling and safety data sheet supplied by the solvent vendor, especially when toxic or hazardous solvents are used.

- 1 Place solvent cabinet with the bottle(s) on top of the micro vacuum degasser.
- 2 Remove the front cover by pressing the snap fasteners on both sides.

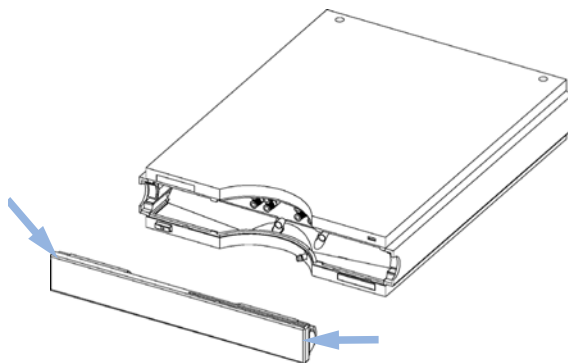

Figure 6 Removing the Front Cover

3 Installing the Micro Vacuum Degasser

Flow Connections to the Micro Vacuum Degasser

- 3 If the micro vacuum degasser is not used with an Agilent 1260 Infinity pump, connect the waste tube from the accessory kit to the waste outlet and place into your waste system.
- 4 Put the bottle head assemblies into solvent bottles containing your mobile phase.
- 5 Connect the solvent tubes from the bottle head assemblies to the inlet connectors A through D (typically the upper connection of the channel) of the micro vacuum degasser. Use the mounting tool shown in [Figure 7](#) on page 22 to fix the tube screw. Fix the tubes in the clips of the micro vacuum degasser.

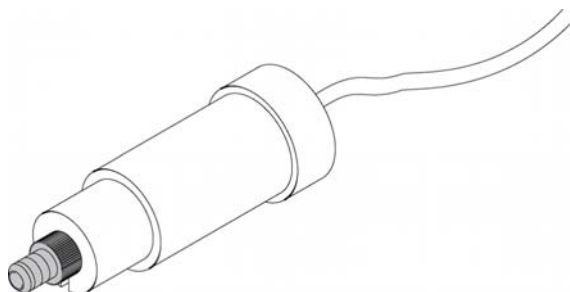

Figure 7 Mounting Tool

- 6 Connect the outlet tubes to the output ports (typically under connection of the channel) of the micro vacuum degasser. Use the mounting tool shown in [Figure 7](#) on page 22 to fix the tube screw.
- 7 Prime the degasser before first use (see [“Priming the Degasser”](#) on page 25).

NOTE

Atmospheric gases can diffuse through the tubing and dissolve in the mobile phase solvents. For best chromatographic results, keep the length of tubing between the micro vacuum degasser and your pump as short as possible.

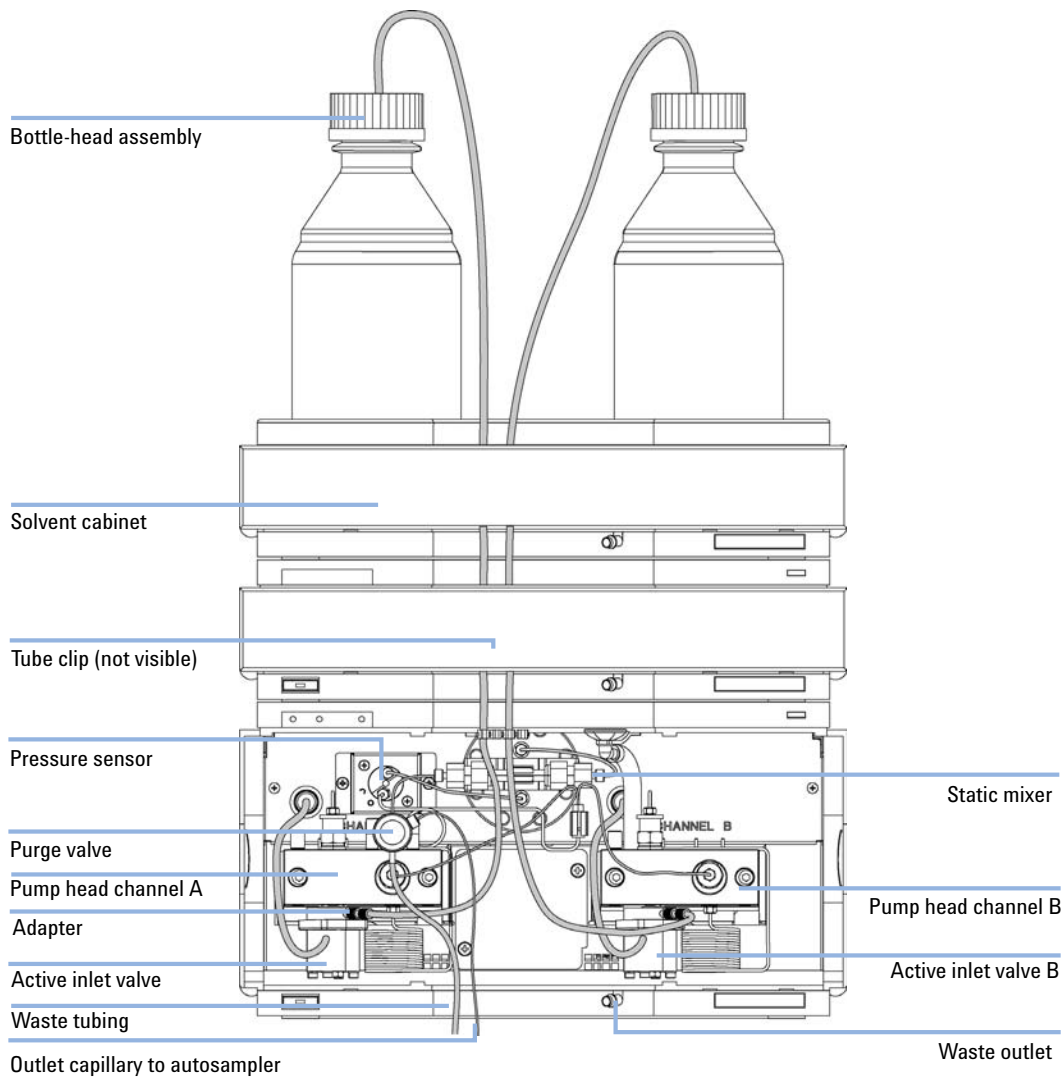

Figure 8 FlowConnection to the Micro Vacuum Degasser

Operational Hints for the Micro Vacuum Degasser

General Priming Instructions

WARNING

When opening capillary or tube fittings solvents may leak out.

The handling of toxic and hazardous solvents and reagents can hold health risks.

→ Please observe appropriate safety procedures (for example, goggles, safety gloves and protective clothing) as described in the material handling and safety data sheet supplied by the solvent vendor, especially when toxic or hazardous solvents are used.

Before using a new degasser or new tubings for the first time:

1 Prime all tubings with at least 5 ml of iso-propanol no matter whether the channels will be used with organic mobile phase or with water.

If you are changing to a solvent that is immiscible with the solvent currently in the tubing continue as follows:

2 Replace the current solvent with iso-propanol, if current solvent is organic or with water, if current solvent is an inorganic buffer or contains salt.

Priming the Degasser

The micro vacuum degasser can be primed by drawing solvent through the degasser by pumping with the connected pump.

For priming the micro vacuum degasser using the pump the following is recommended:

- 1 Connect all tubings to and from degasser and pump.
- 2 Open the pump's purge valve to waste.
- 3 Pump at low to moderate speed, until the solvent reaches into the pump. Pumping at higher flow rates will stress the system and might result in a failure to prime the degasser with the pump.
- 4 Prime each channel of degasser and pump individually with at least 5 ml of solvent.

NOTE

When the pumping system has been turned off for a certain time (for example, overnight) oxygen will rediffuse into the solvent channels between the micro vacuum degasser and the pump. Solvents containing volatile ingredients will slightly lose these, if left in the degasser without flow for a prolonged period of time. Therefore priming of the micro vacuum degasser and the pumping system is required before starting an application.

NOTE

Priming the micro vacuum degasser with a syringe is ONLY recommended, when priming with the pump fails. This might happen because the used solvent is critical or the degasser and pump inlet lines are completely dry and the pump therefore fails to draw the solvent from the solvent bottle through the degasser channels into the pump.

Priming with a Syringe (only recommended if priming with the pump fails)

NOTE

While using a syringe for priming, the degasser must be turned ON. Only draw the solvent through the degasser channels with moderate speed in order to avoid damage to the chambers!

- 1 Disconnect solvent outlet tube of the channel that is supposed to be primed from your pump.
- 2 Connect syringe adapter to solvent outlet tube.
- 3 Push syringe adapter onto syringe.
- 4 Pull syringe plunger to draw at least 5 ml of solvent through degasser and tubing.
- 5 Replace the priming solvent with the new solvent of your choice.
- 6 Pull syringe plunger to draw at least 5 ml of solvent through degasser and tubing.
- 7 Disconnect syringe adapter from solvent tube.
- 8 Connect solvent tube to your pump.
- 9 Repeat step 1 on page 26 to step 8 on page 26 for the other solvent channels.

NOTE

When priming the micro vacuum degasser with a syringe the solvent is drawn through the degasser tubes very quickly. The solvent at the degasser outlet will therefore not be fully degassed. Pump for approximately 5 minutes with your selected flow rate before starting any application. This will allow the micro vacuum degasser to properly degas the solvent in the degasser tubes.

Transporting the Micro Vacuum Degasser

WARNING

Solvents leaking out

Solvents remaining in the solvent channels may leak out during transport. This can possibly cause personal damage.

→ Drain any remaining solvents from the degassing channels before transporting the micro vacuum degasser.

- 1 Pull the solvent inlet tubing out of the solvent bottle of channel A.
- 2 Let the pump draw solvent and air through channel A of the degasser, until the chamber of channel A is completely dry.
- 3 Repeat these steps for the remaining solvent channels.

3 Installing the Micro Vacuum Degasser

Transporting the Micro Vacuum Degasser



4 Using the Micro Vacuum Degasser

When to Use a Micro Vacuum Degasser? 30

Solvent Information 32

Prevent Blocking of Solvent Filters 33



When to Use a Micro Vacuum Degasser?

WARNING

Unspecified Conditions

Operating the instrumentation under conditions other than their intended use might result in a potential safety hazard or might damage the instrumentation.

→ Never operate your instrumentation under conditions other than specified by the vendor.

For capillary LC application with our Agilent 1260 Infinity Capillary and Nano LC System

For high-pressure mixing pumps (binary and binary SL) with low flow rates or when you have following conditions:

- if your detector is used with maximum sensitivity in the low UV wavelength range,
- if your application requires optimum injection precision,
- if your application requires highest retention time reproducibility (mandatory at flow rates below 0.5 ml/min),
- if your sample or detection is sensitive to dissolved oxygen in the mobile phase (degradation),
- with a fluorescence detector,
- with an LC-MS-detector.

NOTE

The Micro Vacuum Degasser is not recommended for the use with low pressure-mixing pumps (e.g. quaternary pump).

Generally a degasser should be used when negative effects due to dissolved gas in the mobile phase exceed the limits that are acceptable for the user. Negative effects that can be caused by dissolved gas are:

- Unstable flow due to unstable pumping conditions. This may result in a high ripple or high standard deviations of peak retention times and peak areas especially at low flow rates.

- Baseline noise on detectors that are sensitive to changes in the refractive index,
- sample degradation,
- fluorescence Quenching due to dissolved oxygen,
- baseline drift in electrochemical detectors due to dissolved oxygen especially in reduction mode.

The micro vacuum degasser has a startup mode, 2 standard operation modes and not ready / error modes:

- In startup mode the vacuum pump constantly works at maximum speed, while the pump is being tested and cleaned for a 2 minutes time period, with the proportional valve being open. After the testing phase, the proportional valve is closed and the instrument is brought to vacuum. The “NOT READY” mode (yellow status indicator) is activate during the degasser’s startup phase.
- In the normal operation mode the vacuum degasser is constantly operated at a pressure of 60 +/- 3 Torr. The speed of the vacuum pump is kept at a constant level, while the “bypass-leak” the proportional valve is varied in order to keep the pressure/degassing level inside the vacuum chambers constant. If the set vacuum level cannot be maintained, while the pump is operated at a constant voltage of 12 V (pump rate 1), the pump is switched to a constant voltage of 24 V (pump rate 2).
- The ERROR mode (red status indicator) is activated in case the degasser cannot achieve a vacuum level of 180 Torr.

(1 Torr = 1.33×10^{-3} bar)

Solvent Information

Always filter solvents through 0.4 µm filters, small particles can permanently block the capillaries and valves. Avoid the use of the following steel-corrosive solvents:

- Solutions of alkali halides and their respective acids (for example, lithium iodide, potassium chloride, and so on).
- High concentrations of inorganic acids like sulfuric and nitric acid, especially at higher temperatures (replace, if your chromatography method allows, by phosphoric acid or phosphate buffer which are less corrosive against stainless steel).

- Halogenated solvents or mixtures which form radicals and/or acids, for example:

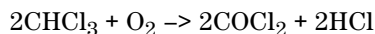

This reaction, in which stainless steel probably acts as a catalyst, occurs quickly with dried chloroform if the drying process removes the stabilizing alcohol.

- Chromatographic grade ethers, which can contain peroxides (for example, THF, dioxane, di-isopropylether). Such ethers should be filtered through dry aluminium oxide which adsorbs the peroxides.
- Mixtures of carbon tetrachloride with 2-propanol or THF dissolve stainless steel.

Prevent Blocking of Solvent Filters

Contaminated solvents or algae growth in the solvent bottle will reduce the lifetime of the solvent filter and will influence the performance of the pump. This is especially true for aqueous solvents or phosphate buffers (pH 4 to 7). The following suggestions will prolong lifetime of the solvent filter and will maintain the performance of the pump.

- Use sterile, if possible amber solvent bottles to slow down algae growth.
- Filter solvents through filters or membranes that remove algae.
- Exchange solvents every two days or refilter.
- If the application permits add 0.0001–0.001 M sodium azide to the solvent.
- Place a layer of argon on top of your solvent.
- Avoid exposure of the solvent bottles to direct sunlight.

Checking the Solvent Filters

The solvent filters are on the low-pressure side of the pumping system. A blocked filter therefore does not affect the pressure readings of the pump. The pressure readings cannot be used to identify blocked filters. If the solvent cabinet is placed on top of the micro vacuum degasser the filter condition can be checked in the following way:

Remove the tubing at the inlet port of the micro vacuum degasser. If the filter is in good condition the solvent will freely drip out of the solvent tube (due to hydrostatic pressure). If the solvent filter is partly blocked no solvent or only very little solvent will drip out of the solvent tube.

Cleaning the Solvent Filters

- Remove the blocked solvent filter from the bottle-head assembly and place it in a beaker with concentrated nitric acid (35%) for one hour.
- Thoroughly flush the filter with bidistilled water (remove all nitric acid).
- Replace the filter.

NOTE

Never use the system without solvent filter installed.

4 Using the Micro Vacuum Degasser

Solvent Information

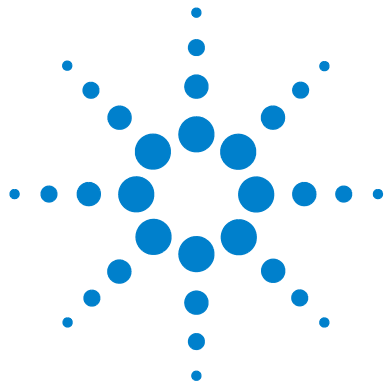

5 Optimizing Performance

Increasing the Degasser Performance and Degassing Level 36



Increasing the Degasser Performance and Degassing Level

For some critical applications it might be useful to increase the degasser's performance and degassing level by using two channels of the degasser in series with only one solvent channel of the pump. For doing so:

- 1** Connect the solvent inlet tubing (bottle head assembly, Bottle-head assembly (p/n G1311-60003)) coming from the solvent bottle to the inlet line of the first channel, you want to use.
- 2** Connect the outlet of the first channel to the inlet of the 2nd solvent channel of the degasser with the help of the short connecting tubing (Connecting tubing (to connect to channels in series for increased performance) 2x (p/n G1379-68706)), delivered with the accessory kit of the degasser.
- 3** Connect a degasser to pump connecting tubing (Kit of 4 solvent tubes for connection degasser to MCGV (Quaternary Pump) including labels (p/n G1322-67300)) to the outlet of the 2nd channel of the degasser and into the pump.

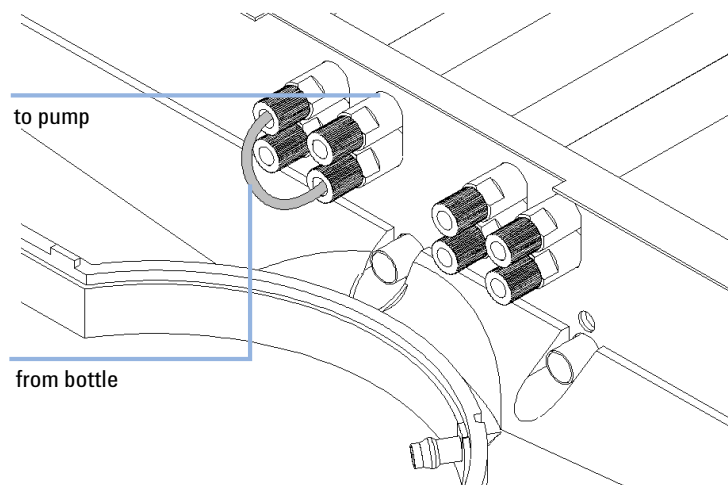

Figure 9 Connecting two degasser channels in series



6 Troubleshooting and Diagnostics

Overview of the Degasser's Indicators	38
Status Indicators	39
Instrument Status Indicator	40
Hardware Symptoms	41
All Lamps are Off	41
If the Status Indicator is Red	42
If the Status Indicator is Yellow and the Vacuum Pump is not Running	42
Status Indicator becomes Red and Vacuum Pump was Running	44



Overview of the Degasser's Indicators

Status Indicators

The micro vacuum degasser is provided with two status indicators which indicate the operational state (ready, busy, and error states) of the micro vacuum degasser. The status indicators provide a quick visual check of the operation of the micro vacuum degasser (see [“Status Indicators”](#) on page 39).

Hardware Symptoms

A red status lamp at the micro vacuum degasser indicates a problem with the vacuum system or with the electronic control. The micro vacuum degasser generates an error output on the remote lines. The following pages describe hardware symptoms which help you to isolate the cause of a hardware failure (see [“Hardware Symptoms”](#) on page 41).

Status Indicators

Two status lamps are located on the front of the micro vacuum degasser. The left lamp indicates the power supply status, the right lamp indicates the micro vacuum degasser status.

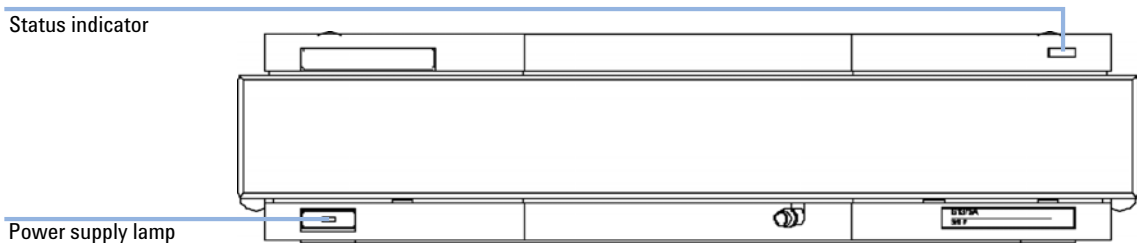

Figure 10 Location of Status Lamps

Power Supply Lamp

The power supply lamp is integrated into the main power switch. When the lamp is illuminated (green), the power is ON.

Instrument Status Indicator

The instrument status indicator indicates one of three possible instrument conditions.

- When the lamp is OFF, the micro vacuum degasser is in *ready* condition (only if the power supply lamp is ON, otherwise, the instrument is switched off, or there is a defect in the power supply). A ready condition exists when there is sufficient vacuum in the micro vacuum degasser.
- A *busy* condition is indicated, when the lamp is yellow. A busy condition exists when the vacuum degasser is in its startup phase.
- An *error* condition is indicated, when the lamp is red. An error condition exists when the micro vacuum degasser detects an internal defect that does not allow the vacuum to be kept below the error threshold (180 Torr).

CAUTION

Error LED is on

This indicates either an internal leak in the vacuum system or an electronic failure.

- In case of an internal leak it is possible that solvent may enter the vacuum chamber and solvent may leak into the waste drain.
 - To prevent any damage, switch off the micro vacuum degasser and remove the solvent bottles from the solvent cabinet to stop any gravity-caused flow of solvent into the vacuum chamber.
-

Hardware Symptoms

In case of a problem with the vacuum system or the electronic control the micro vacuum degasser status lamp will be red. The micro vacuum degasser will generate an error output on the remote lines. This will shut down other system modules when connected via remote cable, see [“Installing the Micro Vacuum Degasser”](#) on page 19. The micro vacuum degasser itself will not be able to generate any error messages in the system logbook of the Agilent 1200 Infinity Series. The following pages describe hardware symptoms which help you to isolate the cause of a hardware failure.

All Lamps are Off

If all other modules in the system are on (power switch lamp is green) and are recognized by the connected user interface (module parameters can be set, module-specific screens appear, and so on), then do the following to determine the problem with the micro vacuum degasser:

- ✓ Ensure the power cable is connected to the degasser, and the power cable is connected to line power.
- ✓ Ensure the power switch on the front of the module is ON.
- ✓ Ensure the power fuses are OK.

The fuse holders are located on the rear panel of the micro vacuum degasser and are part of the power socket. Check the fuses (see [“Exchanging the Fuses of the Power Inline Filter”](#) on page 54), and change if necessary:

- ✓ If the previous steps did not solve the problem, change the control assembly ((Please contact your Agilent service representative)).

If the Status Indicator is Red

Sufficient vacuum is normally built up after the initial start-up and is maintained by controlling the proportional valve as triggered by the vacuum sensor.

If the vacuum cannot be reached, the micro vacuum degasser will be forced into an error state. The error condition can be reset by turning the micro vacuum degasser off and on again.

The following described failure conditions will appear during the start-up procedure before the red error LED is turned on:

If the Status Indicator is Yellow and the Vacuum Pump is not Running

- ✓ Remove the top cover (see “[Removing and Refitting the Top Cover](#)” on page 49).
- ✓ Check the operation of the vacuum pump. Disconnect the vacuum tube from the sensor assembly to the vacuum chamber at the vacuum chamber (see “[Removing and Refitting the Top Cover](#)” on page 49) to adjust the pressure inside the vacuum chamber to ambient conditions. Switch the micro vacuum degasser off and on again. The vacuum pump should start immediately.
- ✓ Use a test meter to check for + 24 V DC on the connector CN2 of the control assembly between pin 1 and 2 (see Overview of Internal Parts in the Service Manual). This voltage is needed to operate the pump. If this voltage is low, exchange the control assembly (Please contact your Agilent service representative).
- ✓ Check the resistance of the motor windings. The windings should have a resistance in the kOhm range (use a test meter to check resistance between red and blue, blue and black, black and red wires from connector CN2 to the pump). If the windings are broken or shortened replace the vacuum pump (Please contact your Agilent service representative).

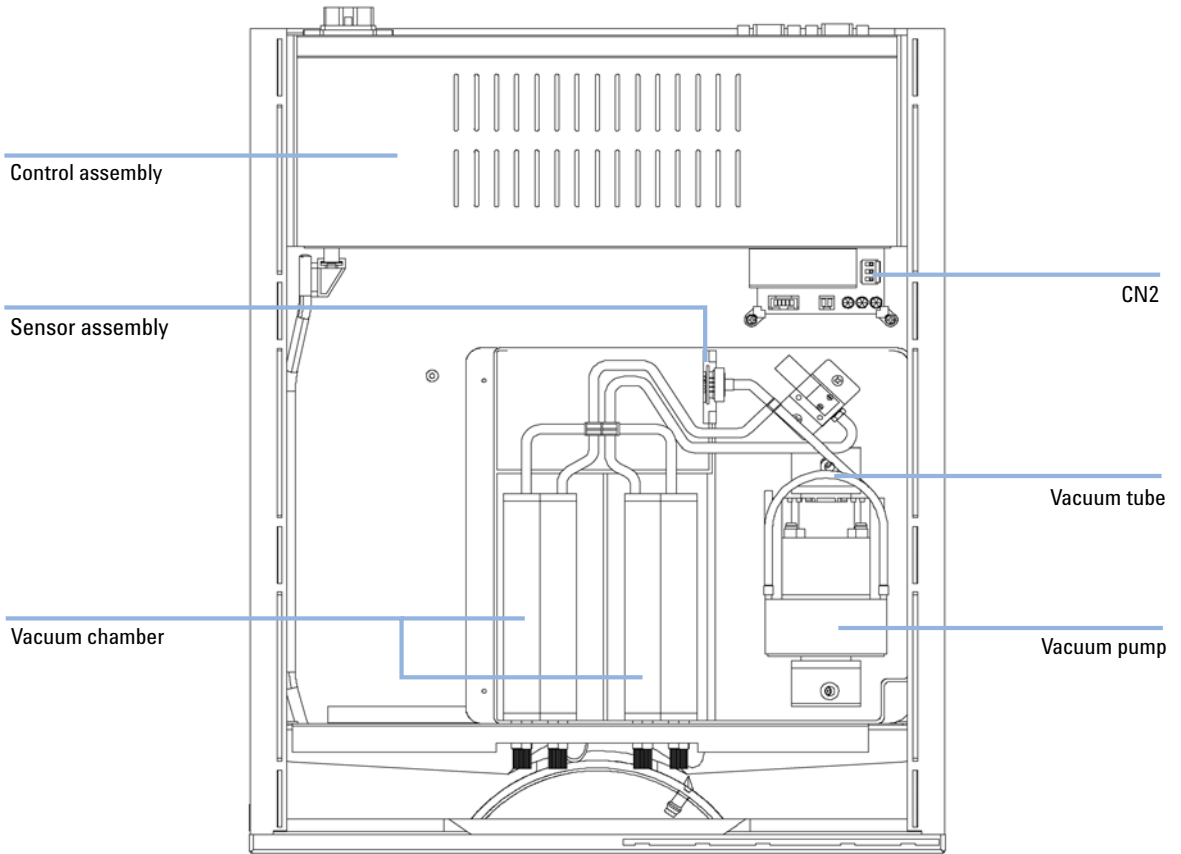

Figure 11 Overview of Main assemblies

Status Indicator becomes Red and Vacuum Pump was Running

Sufficient vacuum is normally built up after the initial start-up and is maintained by controlling the proportional valve as triggered by the vacuum sensor.

If the vacuum cannot be reached, the micro vacuum degasser will be forced into an error state. The error condition can be reset by turning the micro vacuum degasser off and on again.

The following parts can be responsible for an insufficient vacuum:

- 1** Leaky tubing,
- 2** Leaky chambers,
- 3** Defective proportional valve,
- 4** Defective pump,
- 5** Defective electronics.

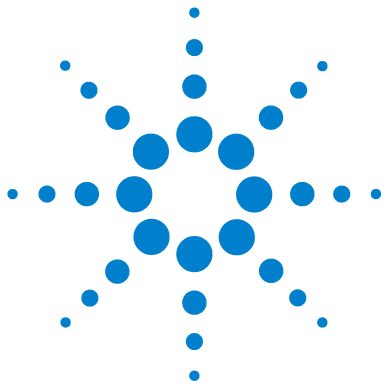

7 Maintenance

Introduction to Maintenance and Repair	46
Simple Repairs	46
Warnings and Cautions	47
Using the ESD Strap	48
Cleaning the Instrument	48
Removing and Refitting the Top Cover	49
Assembling the Main Cover	52
Exchanging the Fuses of the Power Inline Filter	54
Exchanging the Status Light Pipe	56



Introduction to Maintenance and Repair

Simple Repairs

Simple Repairs - Maintenance

The micro vacuum degasser is designed for easy repair. The most frequent repairs such as exchanging power fuses and status light pipes can be performed by the user, but require opening the main cover of the micro vacuum degasser.

Exchanging Internal Parts - Repairs

Most of the repairs require exchange of defective internal parts. Exchange of these parts requires removing the micro vacuum degasser from the stack, removing the covers, and disassembling the micro vacuum degasser. The security lever at the power input socket prevents that the degasser cover is taken off when line power is still connected.

Table 4 Simple Repair Procedures

Procedure	Typical Frequency	Notes
"Exchanging the Fuses of the Power Inline Filter" on page 54	When defective	
"Removing and Refitting the Top Cover" on page 49		
"Assembling the Main Cover" on page 52	If broken	
"Exchanging the Status Light Pipe" on page 56	If broken	

Warnings and Cautions

WARNING

Open main cover

The following procedures require opening the main cover of the instrument.

- Always ensure the instrument is disconnected from the line power when the main cover is removed.
 - The security lever at the power input socket prevents that the instrument cover is taken off when line power is still connected.
-

WARNING

When opening capillary or tube fittings solvents may leak out.

The handling of toxic and hazardous solvents and reagents can hold health risks.

- Please observe appropriate safety procedures (for example, goggles, safety gloves and protective clothing) as described in the material handling and safety data sheet supplied by the solvent vendor, especially when toxic or hazardous solvents are used.
-

CAUTION

The sheet metal plates of the degasser are very thin.

Although they have been deburred, they are still quite sharp. You may cut your hands or fingers.

- Never slide your fingers along the edges of the enclosure.
-

CAUTION

Electronic boards are static sensitive and should be handled with care so as not to damage them. Touching electronic boards and components can cause electrostatic discharge (ESD).

ESD can damage electronic boards and components.

- Be sure to hold the board by the edges and do not touch the electrical components. Always use an ESD protection (for example, an ESD wrist strap) when handling electronic boards and components.
-

Using the ESD Strap

Electronic boards are sensitive to electronic discharge (ESD). In order to prevent damage, always use an ESD strap when handling electronic boards and components.

- 1 Unwrap the first two folds of the band and wrap the exposed adhesive side firmly around your wrist.
- 2 Unroll the rest of the band and peel the liner from the copper foil at the opposite end.
- 3 Attach the copper foil to a convenient and exposed electrical ground.

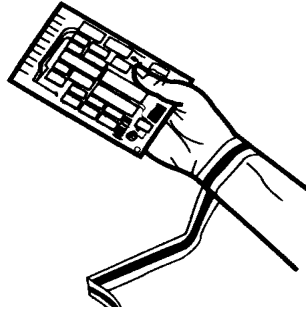

Figure 12 Using the ESD Strap

Cleaning the Instrument

WARNING

Liquid dripping into the electronic compartment of your module.

Liquid in the module electronics can cause shock hazard and damage the module.

- Do not use an excessively damp cloth during cleaning.
- Drain all solvent lines before opening any fittings.

The micro vacuum degasser case should be kept clean. Cleaning should be done with a soft cloth slightly dampened with water or a solution of water and a mild detergent. Do not use an excessively damp cloth that liquid can drip into the micro vacuum degasser.

Removing and Refitting the Top Cover

Tools required Screwdriver Pozidriv #1

- Preparations**
- Switch off the micro vacuum degasser at the main power switch
 - Disconnect the power cable and remote cable
 - Disconnect all solvent tubes from the ports of the micro vacuum degasser
 - Remove solvent cabinet from the micro vacuum degasser
 - Remove micro vacuum degasser from the stack.

WARNING

When opening capillary or tube fittings solvents may leak out.

The handling of toxic and hazardous solvents and reagents can hold health risks.

- Please observe appropriate safety procedures (for example, goggles, safety gloves and protective clothing) as described in the material handling and safety data sheet supplied by the solvent vendor, especially when toxic or hazardous solvents are used.

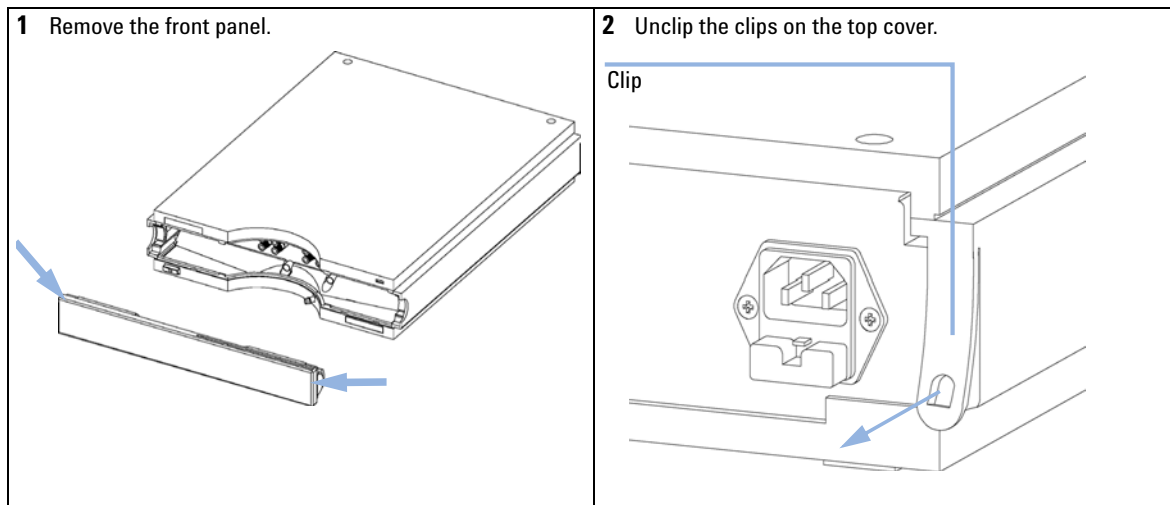

7 Maintenance

Introduction to Maintenance and Repair

3 Lift the cover away.

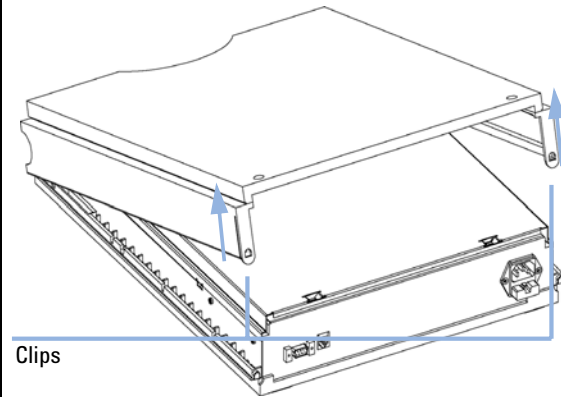

4 Unscrew the screws on the top plate and remove the plate by lifting its back and then sliding the plate to the front.

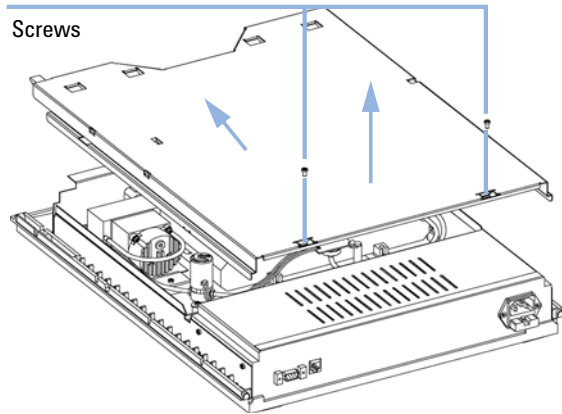

5 Place the metal cover onto the housing. Lower the front of the plate first, then slide panel to the back. Assure the four metal tabs of the panel slide underneath the Z-plane. Fix the two holding screws.

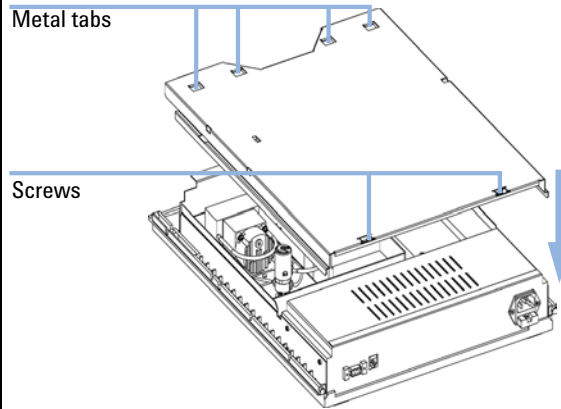

6 Replace the top cover. Ensure the clips are seated correctly.

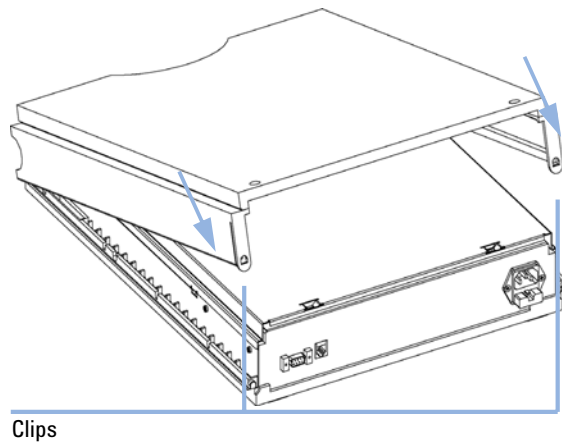

7 Reinstall the front cover.

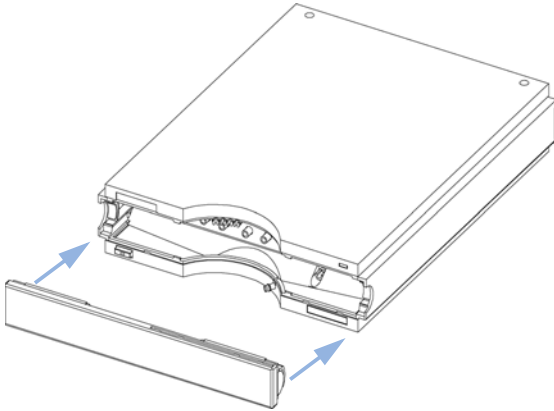

8 Reinstall the micro vacuum degasser in your system stack and connect the cables and capillaries and turn on the vacuum degasser.

Assembling the Main Cover

When If cover is broken

Tools required None

Parts required	#	p/n	Description
	1	5065-9989	Cover kit (includes base, top, left and right)

CAUTION

Wrong assembly

You may not be able to remove the side from the top part.

→ Make sure to install the side parts in the right direction.

NOTE

The cover kit contains all parts, but it is not assembled.

1 Place the top part on the bench and insert the left and right side into the top part.

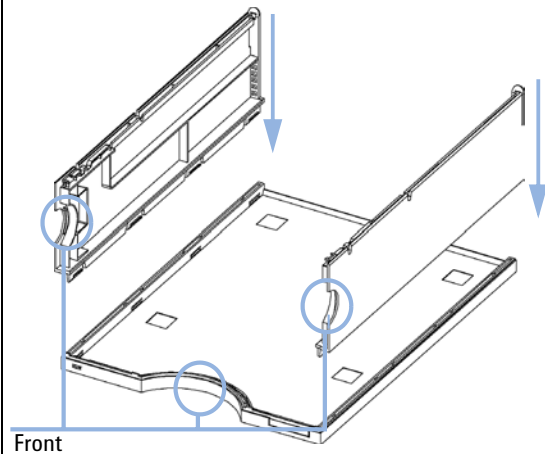

2 Replace the cover.

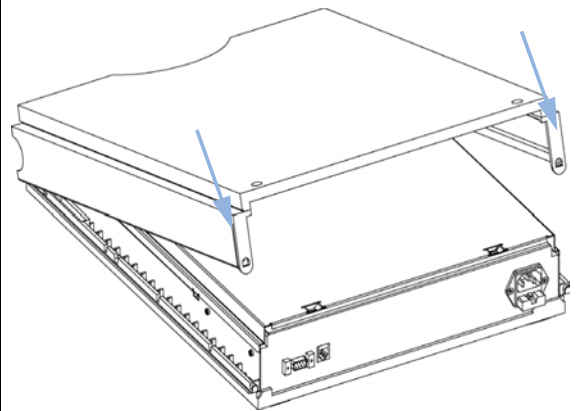

Next Steps:

- 3** Replace the micro vacuum degasser in the stack and reconnect the cables and capillaries.
- 4** Turn on the vacuum degasser.

Exchanging the Fuses of the Power Inline Filter

When	When defective		
Tools required	None		
Parts required	#	p/n	Description
	2	2110-0458	Fuse: 250V, T 500 mA , compatible to all supported line voltages

WARNING

Use of unsupplied cables

Using cables not supplied by Agilent Technologies can lead to damage of the electronic components or personal injury.

→ Never use cables other than the ones supplied by Agilent Technologies to ensure proper functionality and compliance with safety or EMC regulations.

NOTE

The Agilent 1260 Infinity micro vacuum degasser power supply has wide-ranging capability (see [Table 1](#) on page 11). It accepts any line voltage in the range mentioned in the table. Consequently there is no voltage selector in the rear of the Agilent 1260 Infinity micro vacuum degasser. There are two externally accessible fuses, that protect the power supply. These fuses are identical for all accepted line voltages.

- 1 Switch off the power switch at the front of the instrument.
- 2 Remove the power cable from the power connector at the rear of the instrument.

- 3 Press down the clip of the fuse holder and pull out of the power socket.

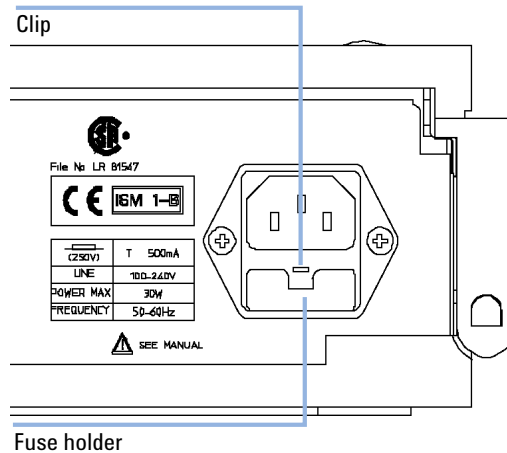

Figure 13 Fuse Holder and Clip

- 4 Remove the fuses from the fuse holders.
- 5 Ensure the fuse wires inside the fuses are not broken. If a test meter is available, check the resistance of each fuse. A good fuse shows a low resistance (approximately 0 Ohm).
- 6 If a fuse is defective (wire broken or high resistance), insert a new fuse.
- 7 Reinsert the fuse holders and the power cable.
- 8 Switch on the power switch.

Exchanging the Status Light Pipe

When If part is broken

Tools required Screwdriver Pozidriv #1

Parts required	#	p/n	Description
	1	5041-8384	Status light pipe

Preparations

- Remove the front cover and top cover, see [“Removing and Refitting the Top Cover”](#) on page 49.

1 The status light pipe is clipped into the top cover.

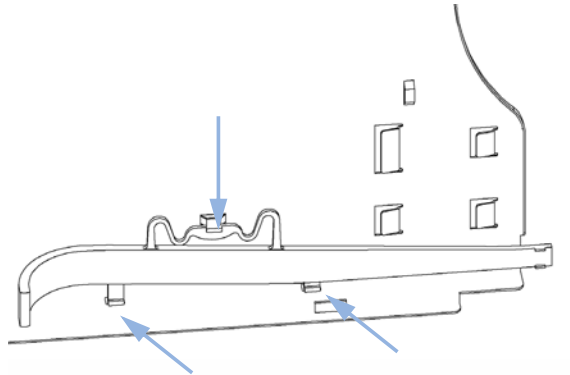

2 Replace the top cover, see [“Removing and Refitting the Top Cover”](#) on page 49.



8 Parts and Materials for Maintenance

Cover Parts cover 58

Sheet Metal Kit 59

Power and Status Light Pipes 60

Accessory Kit 61



8 Parts and Materials for Maintenance

Cover Parts cover

Cover Parts cover

Item	p/n	Description
1	5065-9989	Cover kit (includes base, top, left and right)
2	5065-9990	Front cover
3	5042-8901	Name plate
4	5041-8387	Tube clip

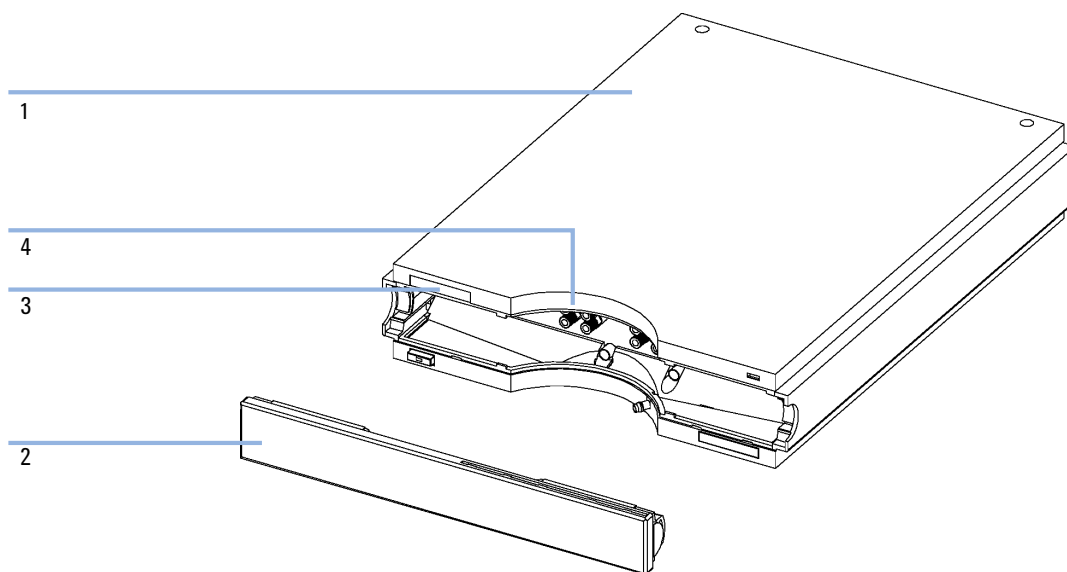

Figure 14 Cover Parts

Sheet Metal Kit

Item	p/n	Description
1	G1379-68702	Sheet metal kit G1379B includes base and top plate

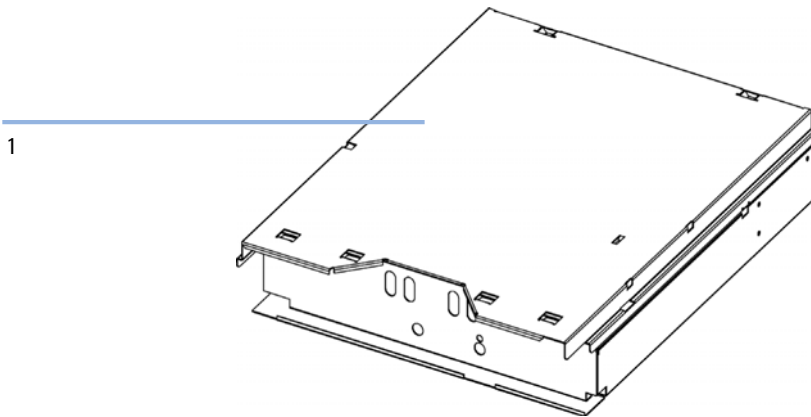

Figure 15 Sheet Metal Kit

Power and Status Light Pipes

Item	p/n	Description
1	5041-8383	Power switch coupler
2	5041-8382	Power switch light pipe
3	5041-8381	Power switch button
4	5041-8384	Status light pipe

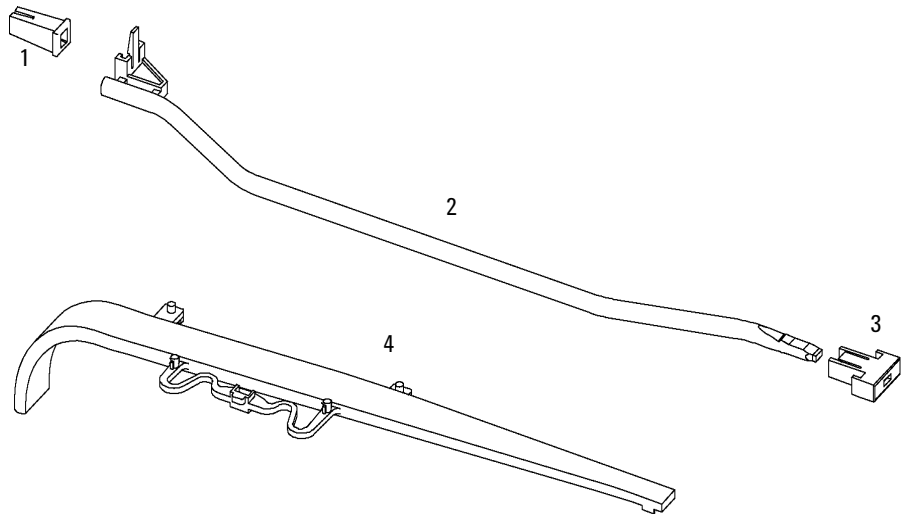

Figure 16 Power and Status Light Pipes

Accessory Kit

Item	p/n	Description
1	G1379-68706	Connecting tubing (to connect to channels in series for increased performance) 2x
2	G1322-67300	Kit of 4 solvent tubes for connection degasser to MCGV (Quaternary Pump) including labels
3	5062-2463	Tubing Flex 5 m
4	0100-1710	Mounting Tool for Tubing Connections

8 **Parts and Materials for Maintenance** Accessory Kit



9 Cable overview

Overview 64

Remote Cable 66



Overview

NOTE

Never use cables other than the ones supplied by Agilent Technologies to ensure proper functionality and compliance with safety or EMC regulations.

Analog cables

p/n	Description
35900-60750	Agilent module to 3394/6 integrators
35900-60750	Agilent 35900A A/D converter
01046-60105	Analog cable (BNC to general purpose, spade lugs)

Remote cables

p/n	Description
03394-60600	Agilent module to 3396A Series I integrators 3396 Series II / 3395A integrator, see details in section “Remote Cable” on page 66
03396-61010	Agilent module to 3396 Series III / 3395B integrators
5061-3378	Agilent module to Agilent 35900 A/D converters (or HP 1050/1046A/1049A)
01046-60201	Agilent module to general purpose

BCD cables

p/n	Description
03396-60560	Agilent module to 3396 integrators
G1351-81600	Agilent module to general purpose

CAN cables

p/n	Description
5181-1516	CAN cable, Agilent module to module, 0.5 m
5181-1519	CAN cable, Agilent module to module, 1 m

LAN cables

p/n	Description
5023-0203	Cross-over network cable, shielded, 3 m (for point to point connection)
5023-0202	Twisted pair network cable, shielded, 7 m (for point to point connection)

External Contact Cable

p/n	Description
G1103-61611	External contact cable - Agilent module interface board to general purposes

RS-232 cables

p/n	Description
G1530-60600	RS-232 cable, 2 m
RS232-61600	RS-232 cable, 2.5 m Instrument to PC, 9-to-9 pin (female). This cable has special pin-out, and is not compatible with connecting printers and plotters. It's also called "Null Modem Cable" with full handshaking where the wiring is made between pins 1-1, 2-3, 3-2, 4-6, 5-5, 6-4, 7-8, 8-7, 9-9.
5181-1561	RS-232 cable, 8 m

Remote Cable

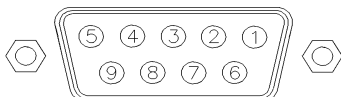

One end of these cables provides a Agilent Technologies APG (Analytical Products Group) remote connector to be connected to Agilent modules. The other end depends on the instrument to be connected to.

Agilent Module to 3396A Integrators

p/n 03394-60600	Pin 3394	Pin Agilent module	Signal Name	Active (TTL)
<p>A diagram of the Agilent module connector, which is a vertical rectangular component with two circular mounting holes at the top and bottom. The left side has a row of pins numbered 1, 3, 5, 7, 9 from bottom to top. The right side has a row of pins numbered 13, 15 from bottom to top.</p>	9	1 - White	Digital ground	
	NC	2 - Brown	Prepare run	Low
	3	3 - Gray	Start	Low
	NC	4 - Blue	Shut down	Low
	NC	5 - Pink	Not connected	
	NC	6 - Yellow	Power on	High
	5,14	7 - Red	Ready	High
	1	8 - Green	Stop	Low
	NC	9 - Black	Start request	Low
	13, 15		Not connected	

Agilent Module to 3396 Series II / 3395A Integrators

Use the cable Agilent module to 3396A Series I integrators (p/n 03394-60600) and cut pin #5 on the integrator side. Otherwise the integrator prints START; not ready.

Agilent Module to 3396 Series III / 3395B Integrators

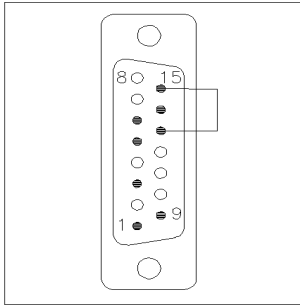
p/n 03396-61010	Pin 33XX	Pin Agilent module	Signal Name	Active (TTL)
	9	1 - White	Digital ground	
	NC	2 - Brown	Prepare run	Low
	3	3 - Gray	Start	Low
	NC	4 - Blue	Shut down	Low
	NC	5 - Pink	Not connected	
	NC	6 - Yellow	Power on	High
	14	7 - Red	Ready	High
	4	8 - Green	Stop	Low
	NC	9 - Black	Start request	Low
	13, 15		Not connected	

Agilent Module to Agilent 35900 A/D Converters

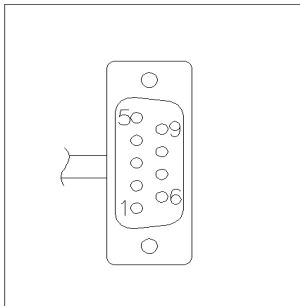
p/n 5061-3378	Pin 35900 A/D	Pin Agilent module	Signal Name	Active (TTL)
	1 - White	1 - White	Digital ground	
	2 - Brown	2 - Brown	Prepare run	Low
	3 - Gray	3 - Gray	Start	Low
	4 - Blue	4 - Blue	Shut down	Low
	5 - Pink	5 - Pink	Not connected	
	6 - Yellow	6 - Yellow	Power on	High
	7 - Red	7 - Red	Ready	High
	8 - Green	8 - Green	Stop	Low
	9 - Black	9 - Black	Start request	Low

Agilent Module to General Purpose

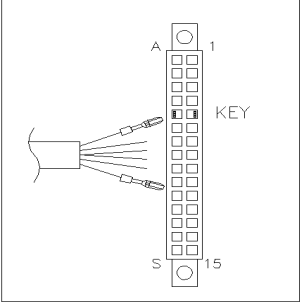
p/n 01046-60201	Pin Universal	Pin Agilent module	Signal Name	Active (TTL)
		1 - White	Digital ground	
		2 - Brown	Prepare run	Low
		3 - Gray	Start	Low
		4 - Blue	Shut down	Low
		5 - Pink	Not connected	
		6 - Yellow	Power on	High
		7 - Red	Ready	High
		8 - Green	Stop	Low
		9 - Black	Start request	Low



10 Appendix

General Safety Information [70](#)

The Waste Electrical and Electronic Equipment "WEEE) Directive
(2002/96/EC) [73](#)

Radio Interference [74](#)

Sound Emission [75](#)

Agilent Technologies on Internet [76](#)

This chapter provides additional information on safety, legal and web.



General Safety Information

General Safety Information

The following general safety precautions must be observed during all phases of operation, service, and repair of this instrument. Failure to comply with these precautions or with specific warnings elsewhere in this manual violates safety standards of design, manufacture, and intended use of the instrument. Agilent Technologies assumes no liability for the customer's failure to comply with these requirements.

WARNING

Ensure the proper usage of the equipment.

The protection provided by the equipment may be impaired.

→ The operator of this instrument is advised to use the equipment in a manner as specified in this manual.

Safety Standards

This is a Safety Class I instrument (provided with terminal for protective earthing) and has been manufactured and tested according to international safety standards.

Operation

Before applying power, comply with the installation section. Additionally the following must be observed.

Do not remove instrument covers when operating. Before the instrument is switched on, all protective earth terminals, extension cords, auto-transformers, and devices connected to it must be connected to a protective earth via a ground socket. Any interruption of the protective earth grounding will cause a potential shock hazard that could result in serious personal injury. Whenever it is likely that the protection has been impaired,

the instrument must be made inoperative and be secured against any intended operation.

Make sure that only fuses with the required rated current and of the specified type (normal blow, time delay, and so on) are used for replacement. The use of repaired fuses and the short-circuiting of fuse holders must be avoided.

Some adjustments described in the manual, are made with power supplied to the instrument, and protective covers removed. Energy available at many points may, if contacted, result in personal injury.

Any adjustment, maintenance, and repair of the opened instrument under voltage should be avoided whenever possible. When inevitable, this has to be carried out by a skilled person who is aware of the hazard involved. Do not attempt internal service or adjustment unless another person, capable of rendering first aid and resuscitation, is present. Do not replace components with power cable connected.

Do not operate the instrument in the presence of flammable gases or fumes. Operation of any electrical instrument in such an environment constitutes a definite safety hazard.





Do not install substitute parts or make any unauthorized modification to the instrument.

Capacitors inside the instrument may still be charged, even though the instrument has been disconnected from its source of supply. Dangerous voltages, capable of causing serious personal injury, are present in this instrument. Use extreme caution when handling, testing and adjusting.

When working with solvents please observe appropriate safety procedures (e.g. goggles, safety gloves and protective clothing) as described in the material handling and safety data sheet by the solvent vendor, especially when toxic or hazardous solvents are used.

Safety Symbols

Table 5 Safety Symbols

Symbol	Description
	The apparatus is marked with this symbol when the user should refer to the instruction manual in order to protect risk of harm to the operator and to protect the apparatus against damage.
	Indicates dangerous voltages.
	Indicates a protected ground terminal.
	Indicates eye damage may result from directly viewing the light produced by the deuterium lamp used in this product.
	The apparatus is marked with this symbol when hot surfaces are available and the user should not touch it when heated up.

WARNING

A WARNING

alerts you to situations that could cause physical injury or death.

- Do not proceed beyond a warning until you have fully understood and met the indicated conditions.

CAUTION

A CAUTION

alerts you to situations that could cause loss of data, or damage of equipment.

- Do not proceed beyond a caution until you have fully understood and met the indicated conditions.

The Waste Electrical and Electronic Equipment "WEEE) Directive (2002/96/EC)

Abstract

The Waste Electrical and Electronic Equipment (WEEE) Directive (2002/96/EC), adopted by EU Commission on 13 February 2003, is introducing producer responsibility on all electric and electronic appliances starting with 13 August 2005.

NOTE

This product complies with the WEEE Directive (2002/96/EC) marking requirements. The affixed label indicates that you must not discard this electrical/electronic product in domestic household waste.

Product Category:

With reference to the equipment types in the WEEE Directive Annex I, this product is classed as a Monitoring and Control Instrumentation product.



NOTE

Do not dispose off in domestic household waste

To return unwanted products, contact your local Agilent office, or see www.agilent.com for more information.

Radio Interference

Cables supplied by Agilent Technologies are screened to provide optimized protection against radio interference. All cables are in compliance with safety or EMC regulations.

Test and Measurement

If test and measurement equipment is operated with unscreened cables, or used for measurements on open set-ups, the user has to assure that under operating conditions the radio interference limits are still met within the premises.

Sound Emission

Manufacturer's Declaration

This statement is provided to comply with the requirements of the German Sound Emission Directive of 18 January 1991.

This product has a sound pressure emission (at the operator position) < 70 dB.

- Sound Pressure $L_p < 70$ dB (A)
- At Operator Position
- Normal Operation
- According to ISO 7779:1988/EN 27779/1991 (Type Test)

Agilent Technologies on Internet

For the latest information on products and services visit our worldwide web site on the Internet at:

<http://www.agilent.com>

Select Products/Chemical Analysis

It will provide also the latest firmware of the modules for download.

Index

A

accessory kit 15, 61
 Agilent
 on internet 76
 algae growth 33
 ambient operating temperature 11
 ambient non-operating temperature 11
 APG remote connector 20

B

bench space 10
 busy condition 40

C

cable
 CAN 20
 GPIB 20
 power 14, 41, 49
 remote 41, 66
 cables
 analog 64
 BCD 64
 CAN 64
 external contact 65
 LAN 65
 overview 64
 remote 64
 RS-232 65
 CAN cable 20
 changing solvents 24, 26
 cleaning the instrument 48
 condensation 10
 control circuit 6
 cover 58

D

dead volume 16
 delay volume 16
 delivery checklist 14
 dimensions 11

E

electronic waste 73
 electrostatic discharge (ESD) 47
 error condition 40
 error state 42, 44
 ESD (electrostatic discharge) strap 48
 exchanging
 solenoid valve 54
 status light pipe 56

F

flow connections 21, 21
 flow rate 12
 frequency range 11
 fuse 41, 54

G

GPIB cable 20

H

hardware symptoms 41
 highest injection precision 30
 highest retention time reproducibility 30
 humidity 11

I

installation
 bench space 10
 internal leak 40
 internet 76
 introduction to the degasser 6

L

lamps
 off, degasser appears dead 41
 status indicator is red 42, 44
 status indicator is yellow, vacuum pump not running 42
 line frequency 11
 line voltage 11

M

main cover, assembling 52
 materials in contact with solvent 12
 maximum flow rate 12
 maximum sensitivity 30
 mounting tool 22, 22

N

non-operating altitude 11
 non-operating temperature 11
 number of channels 12

O

operating Altitude 11
 operating temperature 11
 operational hints 24

Index

P

- parts
 - accessory kit 15, 61
 - cover 58
 - damaged 14
 - light pipes 60
 - missing 14
 - sheet metal kit 59
- performance specifications 12
- pH range 12
- physical specifications 11
- power cable 49
- power light pipe 60
- power supply lamp 39
- power switch 19
- power cable 41
- power consideration 8
- power consumption 11
- power cords 9
- power supply 54
- pressure sensor 6
- priming
 - with a pump 25
 - with a syringe 25
- principle of operation 6

R

- radio interference 74
- ready condition 40
- remote cable 41
- remote
 - cable 66
- repairs
 - using the ESD strap 48

S

- safety class I 70
- safety

- general information 70
- standards 11
- symbols 72

- screwdriver pozidriv #1 49, 56
- sheet metal kit 59
- shipping container 14
- site requirements
 - power cords 9
- snap fastener 21
- solenoid valve 54
- solvent cabinet 49
- solvent filters
 - checking 33
 - cleaning 33
 - prevent blocking 33
- solvent information 32
- sound emission 75
- specification
 - performance specifications 12
 - physical 11
- stack configuration 16
- status indicator 42, 44
- status light pipe 56
- status light pipe 60
- status indicator 39, 42
- syringe adapter 26

T

- tool 22
 - mounting tool 22
- tools
 - screwdriver pozidriv #1 49, 56
- top cover, removing and refitting 49
- transportation 27

V

- vacuum pump 6
- voltage range 11

- voltage selector 54
- volume per channel 12

W

- waste
 - electrical and electronic equipment 73
- WEEE directive 73
- weight 11

Index

In This Book

This manual contains service information about the Agilent 1260 Infinity Micro Degasser.

The manual describes the following:

- introduction,
- site requirements and specifications,
- installing the micro degasser,
- using the micro degasser,
- optimizing performance,
- troubleshooting and diagnostics,
- maintenance,
- parts and materials for maintenance,
- identifying cables,
- appendix.

© Agilent Technologies 2006, 2007-2008, 2010

Printed in Germany
06/10



G1379-90013



Agilent Technologies