

TYLER

series
Advantage

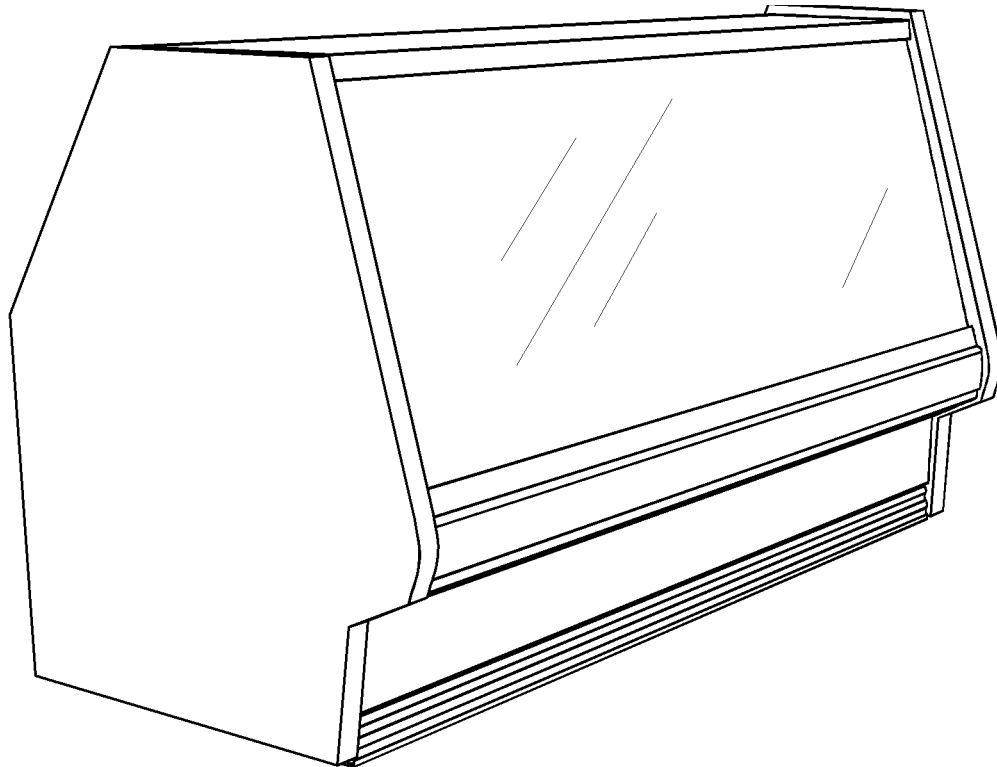

Installation & Service Manual



LVM, LVF, LVD

VERTICAL GLASS MEAT/SEAFOOD/DELI MERCHANDISERS
Medium Temperature Service Display Cases

This manual has been designed to be used in conjunction with the General
Installation & Service Manual.

Save the Instructions in Both Manuals for Future Reference!!

This merchandiser conforms to the Commercial Refrigeration Manufacturers Association Health and Sanitation standard CRS-S1-96.

PRINTED IN U.S.A.	Specifications subject to change without notice.	REPLACES EDITION	1/97	ISSUE DATE	7/99	PART NO.	9027529	REV.	B
-------------------	--	------------------	------	------------	------	----------	---------	------	---

CONTENTS

	<u>Page</u>
Specifications	
LVM/LVF/LVD Specification Sheets	4
Line Sizing Requirements	(See General I&S Manual)
Pre-Installation Responsibilities	(See General I&S Manual)
Installation Procedures	
Carpentry Procedures	6
Case Line-Up	6
Trim Installation	7
Plumbing Procedures	(See General I&S Manual)
Refrigeration Procedures	8
Temperature Control	8
Setting Electronic Thermostat (LVM/LVF)	9
Electrical Procedures	9
Electrical Considerations	9
Defrost Information	9
Defrost Control Chart	9
Installation Procedure Check Lists	(See General I&S Manual)
Wiring Diagrams	9
LV(M/F/D) Domestic & Export (50Hz) Case Circuits (6' Cases) ...	10
LV(M/F/D) Domestic & Export (50Hz) Case Circuits (8' Cases) ...	11
LV(M/F/D) Domestic & Export (50Hz) Case Circuits (12' Cases) ..	12
Cleaning and Sanitation	
Stainless Steel Cleaning Methods	13
General Information	
Rear Sliding Door Removal and Installation	15
Mezzanine Shelving	15
Service Case Flush System	16
Top Mounted Scale Shelf Installation	17

	<u>Page</u>
Service Instructions	
Preventive Maintenance (See General I&S Manual)	
Light Servicing	18
Ballast and Lighting Locations	18
Fan Blade and Motor Replacement (See General I&S Manual)	
Color Band and Bumper Replacement . . (See General I&S Manual)	
Parts Information	
Operational Parts List	19
Cladding and Trim Parts List	20
TYLER Warranty (See General I&S Manual)	

The following Medium Temperature Vertical Glass Meat, Seafood and Deli Service Merchandiser models are covered in this manual:

MODEL	DESCRIPTION
LVM	6', 8' & 12' VERTICAL GLASS GRAVITY COIL MEAT SERVICE MERCHANDISER
LVF	6', 8' & 12' VERTICAL GLASS GRAVITY COIL SEAFOOD SERVICE MERCHANDISER
LVD	6', 8' & 12' VERTICAL GLASS FORCED AIR DELI SERVICE MERCHANDISER

LVM/LVF/LVD Vertical Glass Service Merchandiser Specification Sheets

MODEL	LVM/LVF	LVM/LVF	LVF	LVD	LVD
USAGE	SINGLE UNIT GRAVITY MEAT/FISH	PARALLEL SYSTEM GRAVITY MEAT/FISH	ICED DISPLAY GRAVITY FISH	SINGLE UNIT FORCED AIR DELI	PARALLEL SYSTEM FORCED AIR DELI
BTUH/FT	278	185	150	425	283
SUCTION°	+20F	+15F	+20F	+25F	+20F

THE ABOVE RATINGS ARE FOR COMPRESSOR SELECTION ONLY. FOR ENERGY CALCULATION DATA REFER TO THE ENERGY SECTION.

NOTE: FOR COMPRESSOR SIZING INFORMATION REFER TO THE "GOLD" SECTION & FOR LINE SIZING INFORMATION REFER TO THE "BUFF" SECTION OF THE TYLER SPECIFICATION GUIDE.

CASE-TO-CASE SUCTION LINE SUB-FEED BRANCH LINE SIZING												
R22 SINGLE GRAVITY	3/8"	3/8"	1/2"	1/2"	1/2"	1/2"	5/8"	5/8"	5/8"	5/8"	5/8"	7/8"
R22 PARALLEL GRAVITY	3/8"	3/8"	3/8"	3/8"	1/2"	1/2"	1/2"	1/2"	5/8"	5/8"	5/8"	5/8"
R22 SINGLE FORCED AIR	3/8"	1/2"	1/2"	1/2"	5/8"	5/8"	5/8"	7/8"	7/8"	7/8"	7/8"	7/8"
R22 PARALLEL FORCED AIR	3/8"	3/8"	1/2"	1/2"	1/2"	1/2"	5/8"	5/8"	5/8"	5/8"	7/8"	7/8"

DEFROST CONTROL					EPR SETTINGS	
PER DAY	MODE	TIME	CUT IN	CUT OUT	R22	R404A
1 GRAVITY	TIME OFF	110 MIN.	41# @ R22	32# @ R22	34#	---
1 FORCED AIR	TIME OFF	60 MIN.	53# @ R404A	42# @ R404A	---	44#

CONVENIENCE OUTLET CIRCUIT: One single convenience outlet is on the back of the 6' case and two single convenience outlets are on the back of the 8' & 12' cases. Plan suitable 15A circuits for these 120V outlets.

An evaporator Pressure Regulator should be installed on each system to aid in temperature control. Set the EPR for 34 PSIG (R-22)

Shelves in Gravity Coil cases disrupt air flow and can compromise performance. Shelves work better in Blower style cases.

Pressure Control Settings shown in the above table are for backup purposes only. The actual temperature control should be set by the thermostat. LVM setting for this case = CUT IN @ 29F and CUT OUT @ 19F. LVF setting for this case = CUT IN @ 34F and CUT OUT @ 33F.

CASE BTUH REQUIREMENTS are calculated to produce approximately the indicated entering air temperature with absolute maximum operating ambient limits of **75F & 55RH**.

The information contained herein is based on technical data and tests which we believe to be reliable and is intended for use by persons having technical skill, at their own discretion and risk. Since conditions of use are outside Tyler's control, we can assume no liability for results obtained or damages incurred through the applications of the data presented. SPECIFICATIONS ARE SUBJECT TO CHANGE WITHOUT NOTICE.

LVM/LVF/LVD Vertical Glass Service Merchandiser

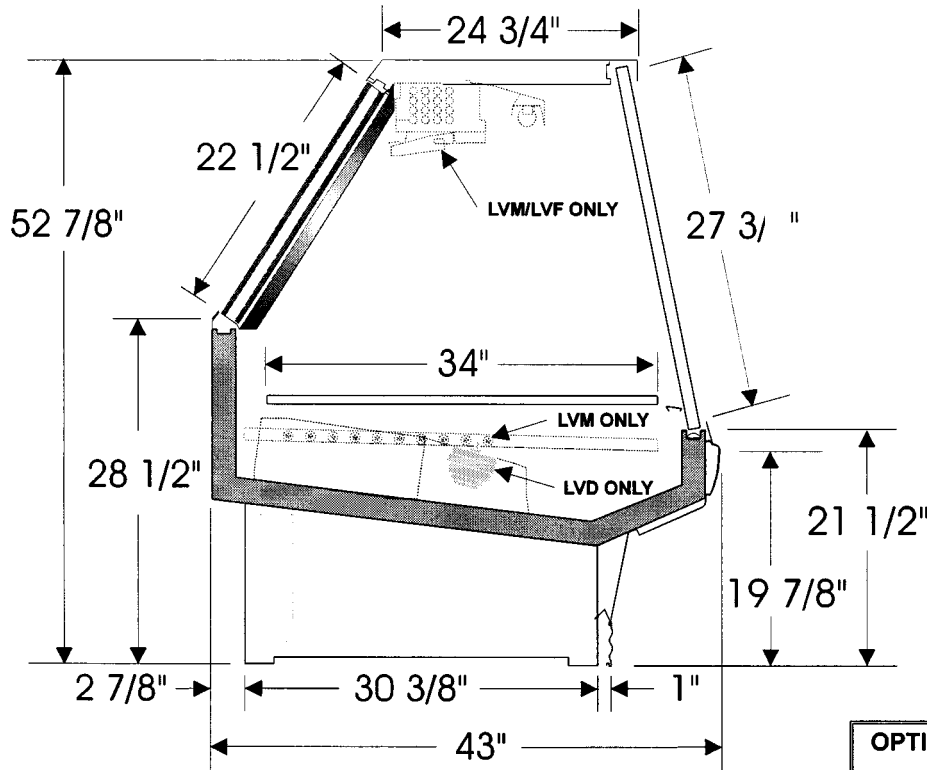

120 VOLT ELECTRICAL DATA (AMPS)		
FT	STD FANS (LVD)	ECM FANS (LVD)
6	1.0	.4
8	1.0	.4
12	1.5	.6

STANDARD 120 VOLT LIGHTING (AMPS) T-8/ ELECTRONIC BALLASTS (CANOPY)			
ROW	6'	8'	12'
1	.5	.6	.9
2	1.0	1.2	1.8
OPTIONAL FLOOR LIGHT			
1	.5	.6	.9

OPTIONAL 120 VOLT LIGHTING (AMPS) T-8/ ELECTRONIC BALLASTS (MEZZANINE)			
ROW	6'	8'	12'
1	.5	.6	.9
2	1.0	1.2	1.8

FLOOR PLAN

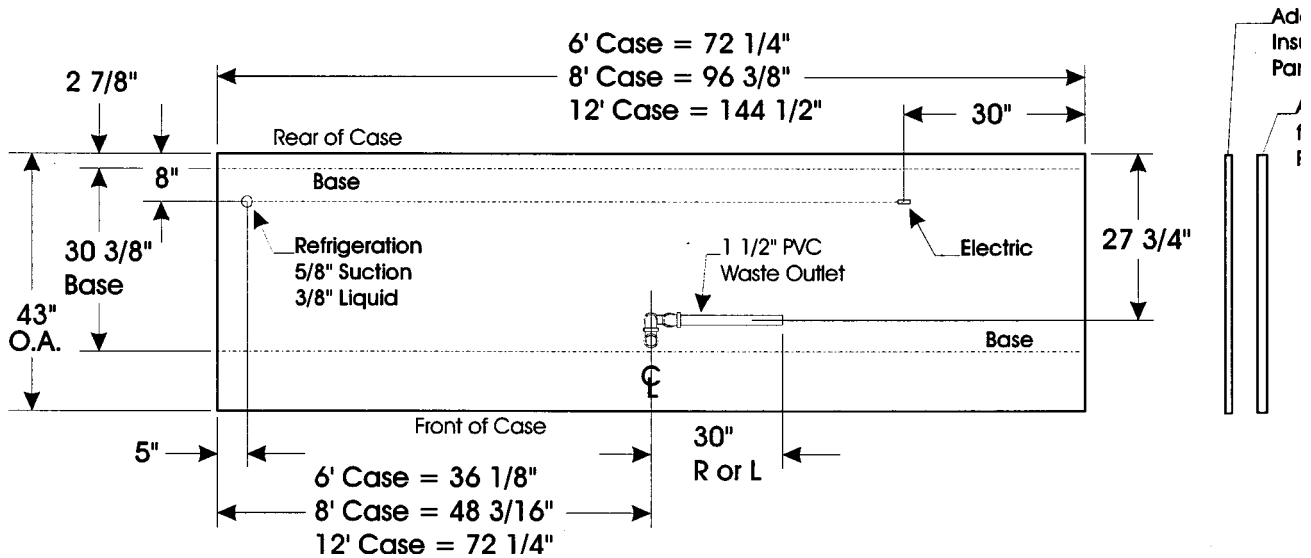

INSTALLATION PROCEDURES

Carpentry Procedures

Case Line-Up

Before starting the case line-up, review the store layout floor plans and survey the areas where case line-ups are going to be installed.

WARNING

These cases are very heavy and require two or more people to move and/or position them. Improper handling of these cases could result in personal injury.

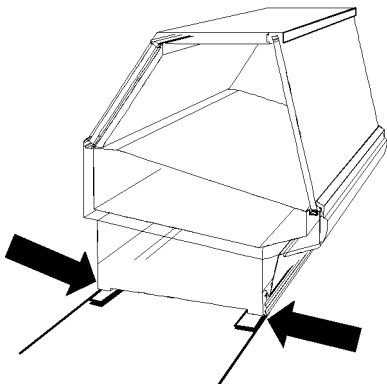

1. Snap chalk lines where the front and rear base rails of the case are to be located for the entire line-up.

NOTE

Front and rear edges of base rails should always be used to line-up cases. 6" shims allow adjoining ends of cases to be shimmed together.

2. Locate highest point on chalk lines as a reference for determining the number of shims to be placed under the case base rails. Position first case at highest point on the chalk lines and shim case supports as required. Check leveling across the top of the case.

CAUTION

If the base of this case is not sitting evenly on the floor, the case could warp when loaded and possibly break the glass.

NOTE

A foam gasket is factory installed on one end of the case. This gasket fits into a groove on the adjoining case when cases are pulled together. Do not depend on the foam gasket alone to make a good seal!

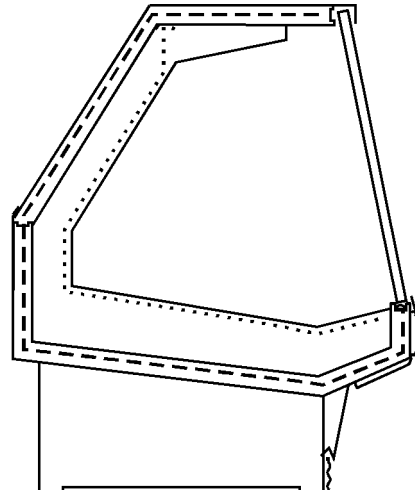

3. Apply two heavy beads of caulking compound from the Filler Kit to the end of case at dotted (. . .) and dashed (- - -) lines. Proper caulking provides good case refrigeration and sanitation.
4. Remove shipping tape from color band backer and bumper backer.

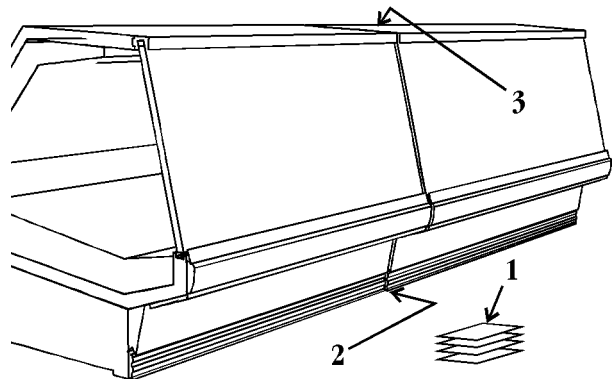

5. Push cases tightly together making sure the pull-ups are aligned.
6. Add shims (1), as required, under the adjoining case base rails (2). Check leveling at top of the case (3).

CAUTION

Do not drill or use other holes through the case end for pull-ups. This may deform the case end and could cause joint leaks and/or poor refrigeration.

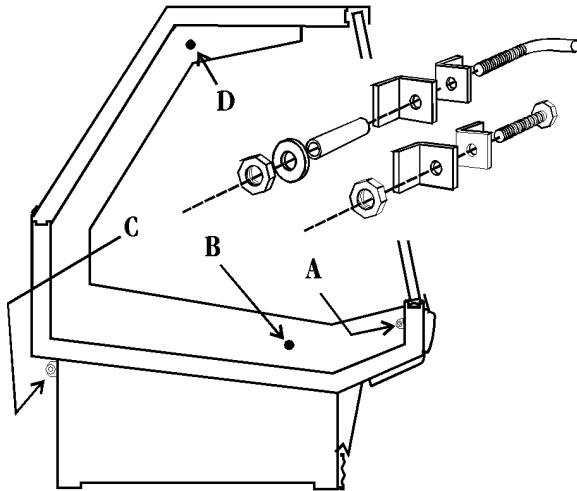

7. Position pull-up bolts and mounting hardware at pull-up locations (A, B, C and D). Do not tighten any pull-up hardware until all of it has been installed. Tighten all pull-up hardware equally starting at point A and finishing at point D. **Do not over-tighten.**

Trim Installation

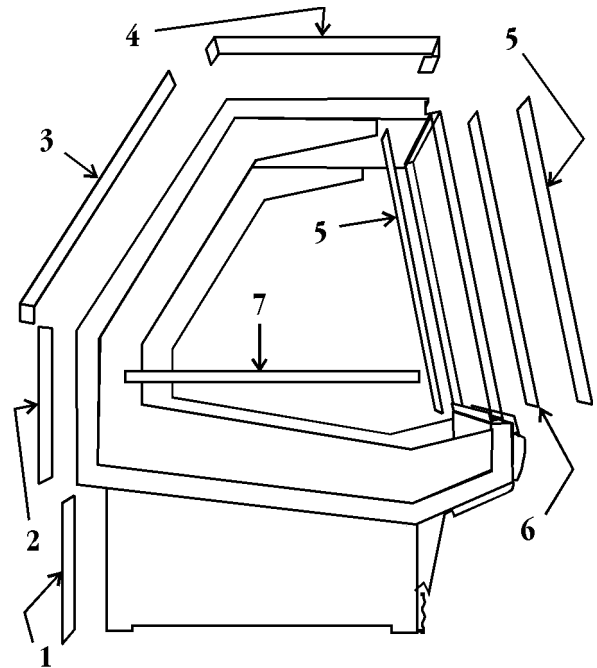

All joint trim and mounting hardware is shipped loose. Joint trim includes rear base joint trim (1), rear lower joint trim (2), rear upper joint trim (3), top joint trim (4), outer and inner glass joint trim (5), compound tape (6) and horizontal joint trim (7).

Horizontal joint trim covers gaps between the cases. The trim is glued onto the shipping cardboard. It is applied after running beads of caulking on the edges of the cases. Sheet metal screws or pop-rivets can be used for additional securing.

NOTE

Compound sealing tape can be added to inside surfaces of inner and outer glass joint trim to make the trim level and even.

Glass joint trim pieces are secured to inside and outside of the glass joint with compound tape.

Patch end trim is shipped factory installed. The compound tape has already been installed under the trim. Check and/or trim any exposed compound tape.

See "General I&S Manual" for bumper and color band installation and alignment.

Refrigeration Procedures

Refrigeration system and superheat instructions can be found in the "General I&S Manual". Service case temperature control information is listed below.

Temperature Control

The temperature of each case is controlled with a thermostat and suction line solenoid. One thermostat and one solenoid are required for up to three cases.

The LVM and LVF cases use a gravity coil with an electronic thermostat for improved temperature control. LVD cases use a conventional mechanical thermostat.

Typical Service Case with Gravity Coil

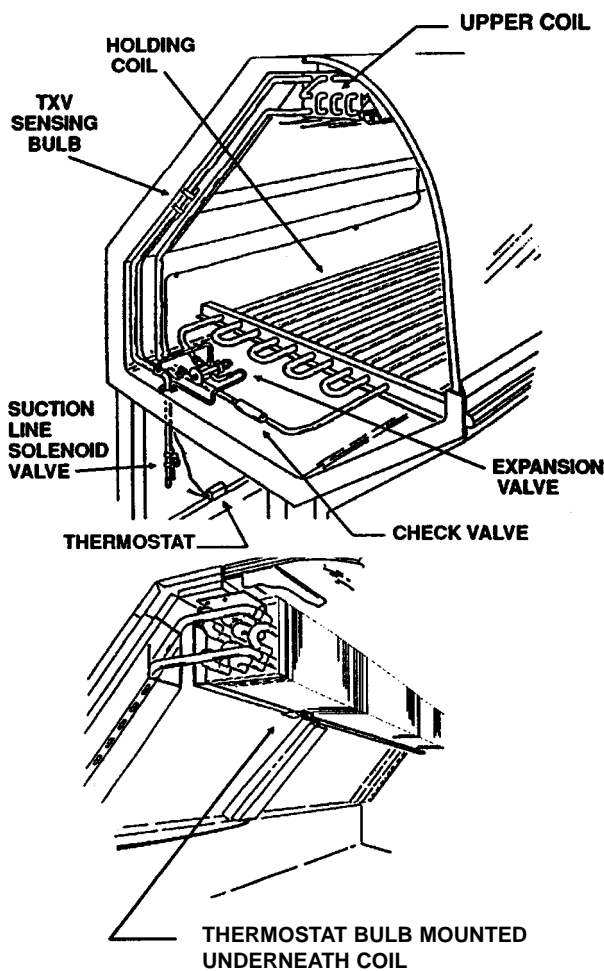

THERMOSTAT BULB PLACEMENT

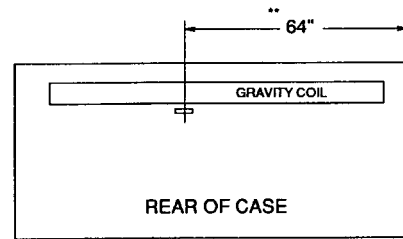

** 64" APPLIES TO 8 & 12 FOOT CASES ONLY. LOCATE APPROXIMATELY IN CENTER OF CASE FOR 6 FOOT CASES. HOOK ONTO COIL FIN GUARD AS SHOWN BELOW

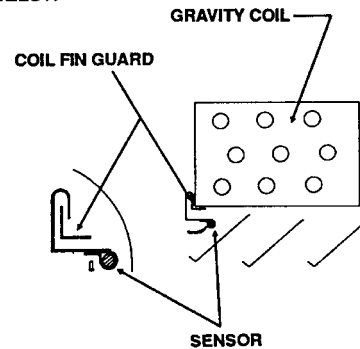

Typical Service Case with Blower Coil

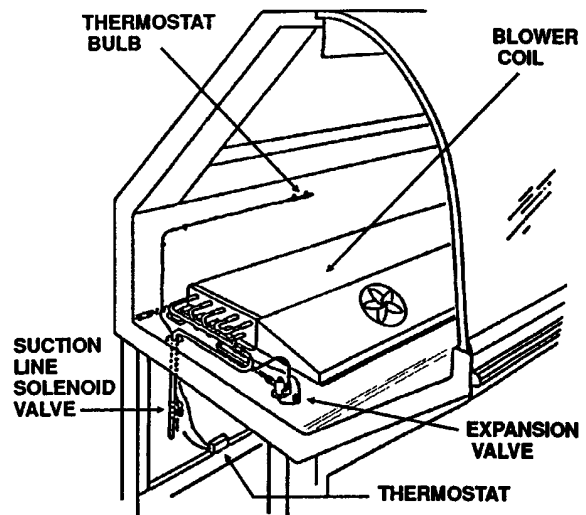

In addition to the thermostat and suction solenoid, a suction stop EPR valve is required in the suction line. The EPR valve acts as a low pressure limit to aid in the overall temperature control.

Setting Electronic Thermostat (LVM/LVF)

1. Remove the four screws and cover from the electronic thermostat.
2. Set the heating/cooling jumper blocks to the "COOL" position.
3. Adjust the differential potentiometer marked "DIFF" to 10°F (LVM) or 1°F (LVF).
4. Position the setpoint dial, on the front cover, to 29°F (LVM) or 34°F (LVF).
5. Check the temperature cycles by suspending a thermometer in the same general area as the thermostat probe. The temperature should cycle between 19°F and 29°F (LVM) or 33°F and 34°F (LVF).
6. Replace the cover and secure with four screws.

With the cooling mode selected, the differential is below the setpoint. The relay will energize and the LED indicator will illuminate when the temperature reaches the setpoint (29°F or 34°F). When the temperature drops to the setpoint (29°F or 34°F) minus the differential setting (10°F or 1°F), the relay and LED indicator will de-energize and refrigeration will stop.

Start the refrigeration system (note that the LED indicator is illuminated) and allow the case to cool. This allows the thermostat to cycle the suction solenoid valve from open to close.

The settings above are specific to TYLER service cases with gravity coils only. Other applications will require different setpoints

Electrical Procedures

Electrical Considerations

CAUTION

Make sure all electrical connections at components and terminal blocks are tight. This prevents burning of electrical terminals and/or premature component failure.

NOTE

The ballast box is located at the lower left rear corner of the case. It houses ballasts and terminal blocks.

Case Fan Circuit (LVD Only)

This circuit is to be supplied by an uninterrupted, protected 120V circuit. The case fan circuit is not cycled on this case.

Fluorescent Lamp Circuit

LV(M/F/D) case lighting is supplied by T-8 electronic ballast lights. It is controlled by a light switch in each case. The standard lighting is 1-row of T-8 canopy lights.

Defrost Information

See "General I&S Manual" for operational descriptions for each type of defrost control.

Defrost Control Chart

LVM/LVF Defrost Option Settings

Defrost Type	Defrosts Per Day	Defrost Duration (Min)	Term. Temp.
Off Time	1	110	-----

LVD Defrost Option Settings

Defrost Type	Defrosts Per Day	Defrost Duration (Min)	Term. Temp.
Off Time	1	60	-----

Thermostats and sensors are shown on page 8 of this manual.

WIRING DIAGRAMS

ELECTRICIAN NOTE - OVERCURRENT PROTECTION

120V circuits should be protected by 15 or 20 Amp devices per the requirements noted on the cabinet nameplate or the National Electrical Code, Canadian Electrical Code - Part 1, Section 28. 208V defrost circuits employ No. 12 AWG field wire leads for field connections. On remote cases intended for end to end line-ups, bonding for ground may rely upon the pull-up bolts.

LVM/LVF/LVD Domestic & Export (50Hz) Case Circuits (6' Cases)

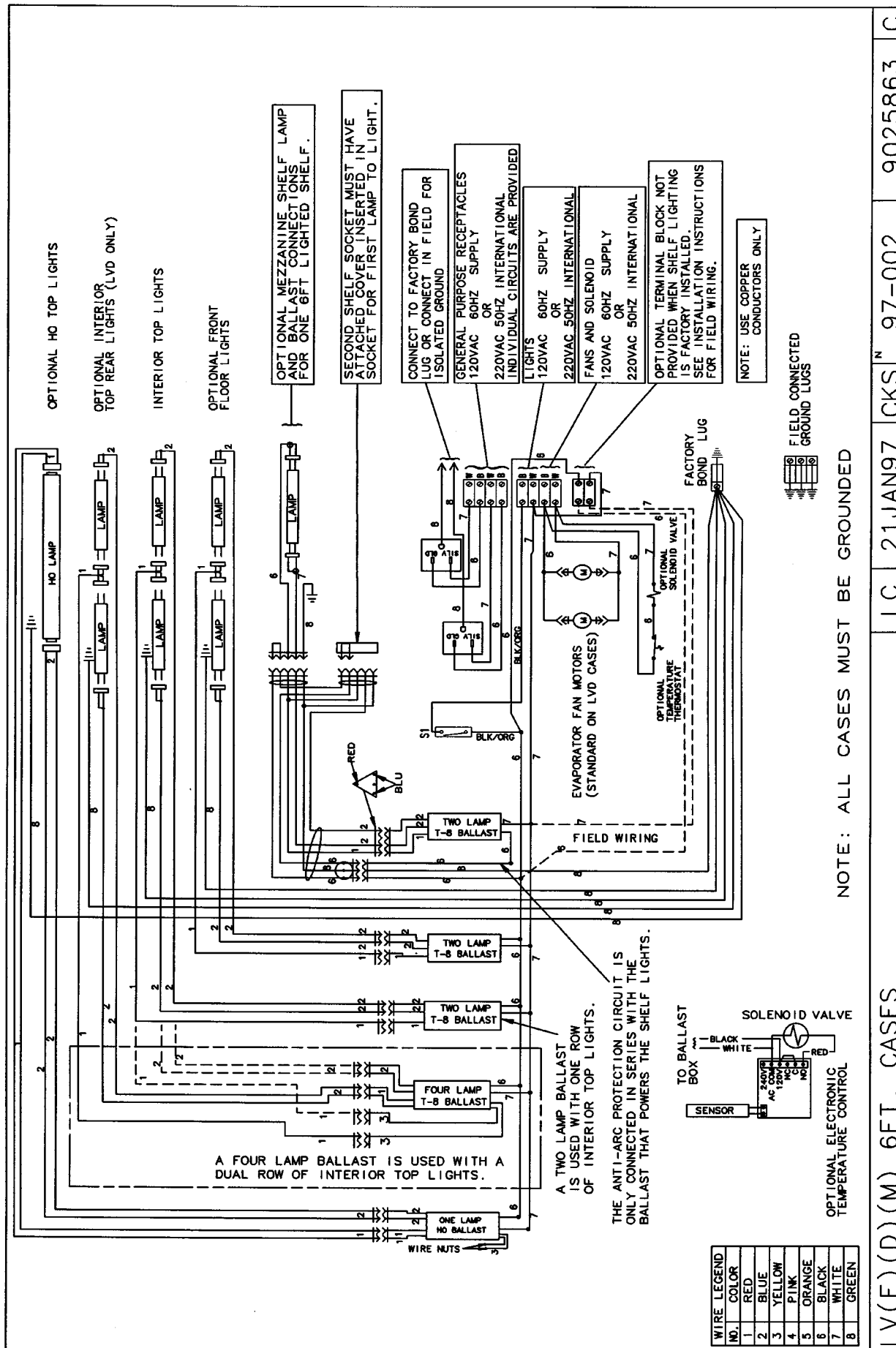

LV(F)(D)(M) 6FT. CASES LC 21JAN97 CKS^N 97-002 9025863 C

LVM/LVF/LVD Domestic & Export (50Hz) Case Circuits (8' Cases)

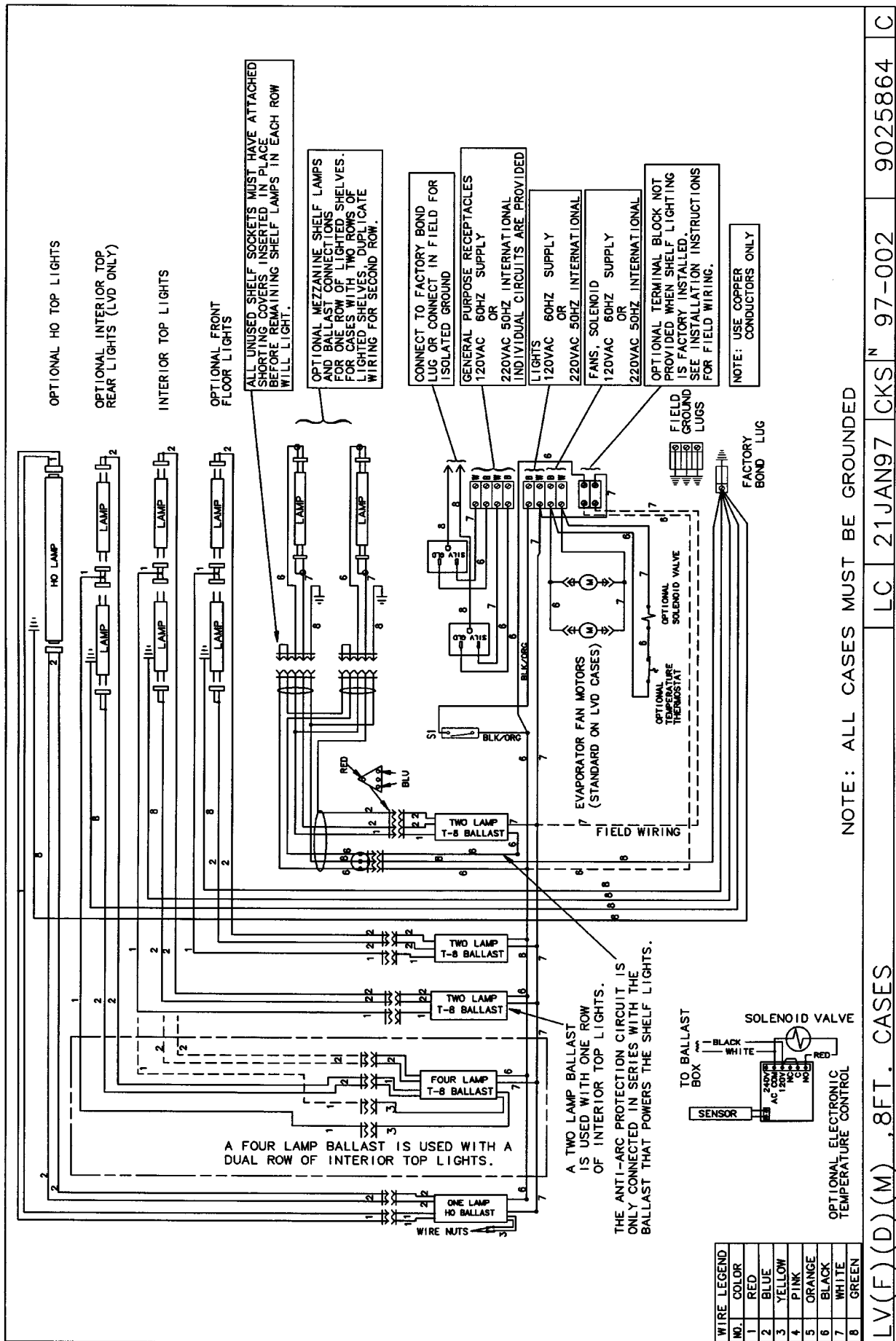

LVM/LVF/LVD Domestic & Export (50Hz) Case Circuits (12' Cases)

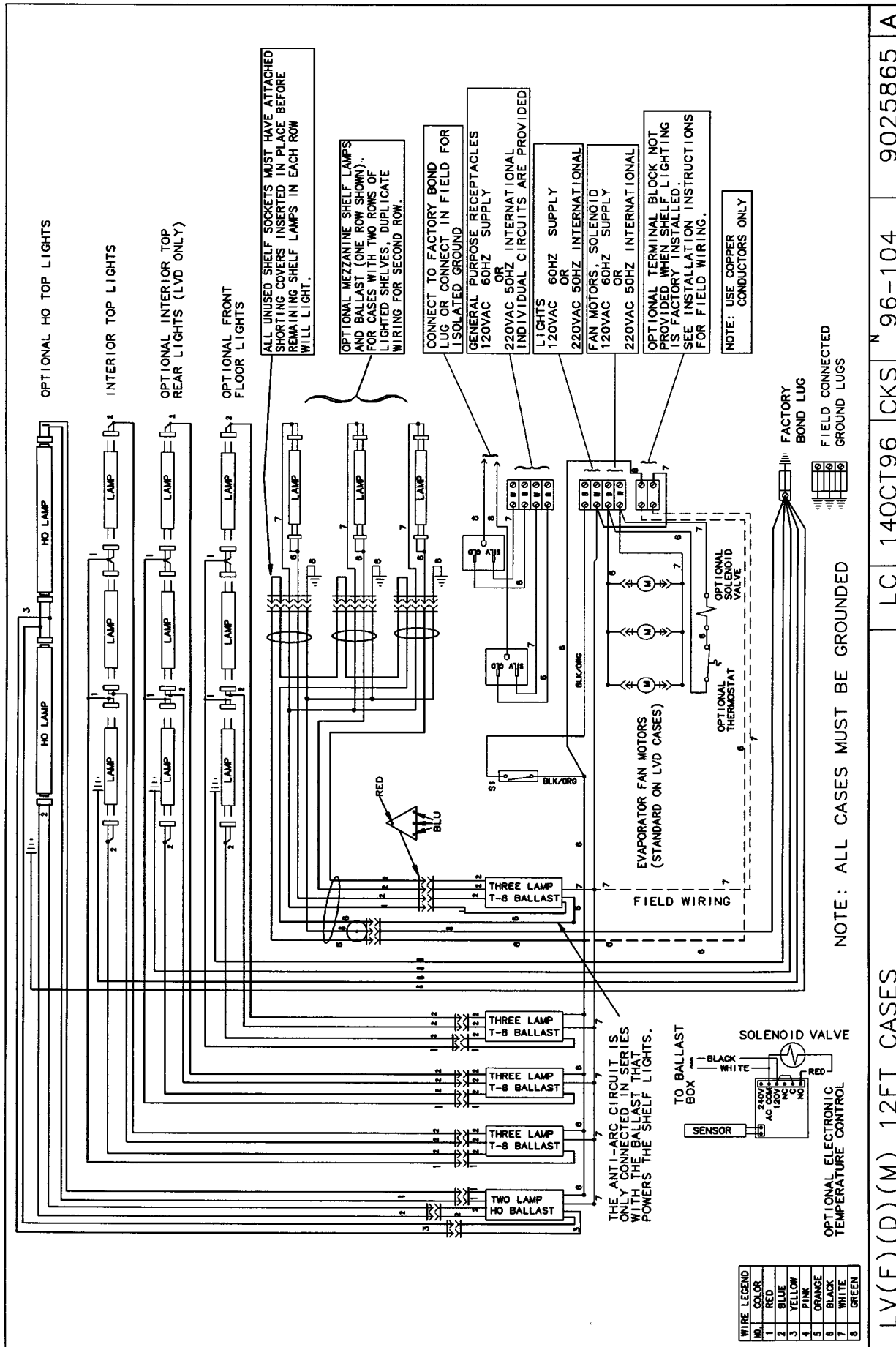

CLEANING INSTRUCTIONS

WARNING

TYLER Refrigeration does not recommend the use of high pressure cleaning equipment on service style cases!! The sealing of front glass and end joints is critical in these cases and high pressure cleaners can penetrate and/or damage these seals. Damaged seals allow water leaks and/or air leaks that can cause poor case refrigeration.

CAUTION

- When cleaning this case, try not to introduce water into the case faster than it can be carried away by the waste outlet.
- Always use a soft cloth or sponge with mild detergent and water to clean the front glass. Never use abrasives or scouring pads to clean glass. They can scratch and/or damage the glass.

See "General I&S Manual" for case cleaning instructions. Stainless steel cleaning is covered in the following chart.

Stainless Steel Cleaning Methods

The cleaning data in the following stainless steel cleaning chart was supplied by AISI. The information was supplied by Prime Metals Division, Alumax Aluminum Corporation.

<u>TYPE OF CLEANING</u>	<u>CLEANING AGENT*</u>	<u>APPLICATION METHOD**</u>	<u>EFFECT ON FINISH</u>
Routine cleaning	Soap, ammonia or detergent and water.	Sponge with cloth, then rinse with clear water and wipe dry.	Satisfactory for use on all finishes.
Smears and fingerprints	Arcal 20, Lac-O-Nu, Lumin Wash O'Cedar Cream Polish, Stainless Shine	Rub with cloth as directed on the package.	Satisfactory for use on all finishes. Provides barrier film
Stubborn spots and stains, baked-on splatter, and other light discolorations	Allchem Concentrated Cleaner	Apply with damp sponge or cloth.	Satisfactory for use on all finishes.
	Samae, Twinkle, or Cameo Copper Cleaner	Rub with damp cloth.	Satisfactory for use on all finishes if rubbing is light.
	Grade FFF Italian pumice, whitening or talc	Rub with damp cloth.	Use in direction of polish lines on No. 4 (polished) finish. May scratch No. 2 (mill) and No. 7 and 8 (polished) finishes.
	Liquid NuSteel	Rub with dry cloth. Use a small amount of cleaner.	Use in direction of polish lines on No. 4 (polished) finish. May scratch No. 2 (mill) and No. 7 and 8 (polished) finishes.
	Paste NuSteel or DuBois Temp	Rub with dry cloth. Use a small amount of cleaner.	Use in direction of polish lines on No. 4 (polished) finish. May scratch No. 2 (mill) and No. 7 and 8 (polished) finishes.
	Cooper's Stainless Steel Cleaner, Revere Stainless Steel Cleaner	Apply with damp sponge or cloth.	Use in direction of polish lines on No. 4 (polished) finish. May scratch No. 2 (mill) and No. 7 and 8 (polished) finishes.
	Household cleaners (Old Dutch, Lighthouse, Sunbrite, Wyandotte, Bab-O, Gold Dust, Sapolio, Bon Ami, Ajax or Comet)	Rub with a damp cloth. May contain chlorine bleaches. Rinse thoroughly after use, if left on surface, may lead to corrosion.	Use in direction of polish lines on No. 4 (polished) finish. May scratch No. 2 (mill) and No. 7 and 8 (polished) finishes.

<u>TYPE OF CLEANING</u>	<u>CLEANING AGENT*</u>	<u>APPLICATION METHOD**</u>	<u>EFFECT ON FINISH</u>
	Grade F Italian pumice, Steel Bright, Lumin Cleaner, Zud, Restoro, Bon Ami, Ajax or Comet	Rub with a damp cloth.	Use in direction of polish lines on No. 4 (polished) finish. May scratch No. 2 (mill) and No. 7 and 8 (polished) finishes.
	Penny-Brite or Copper-Brite	Rub with a dry cloth. Use a small amount of cleaner.	Use in direction of polish lines on No. 4 (polished) finish. May scratch No. 2 (mill) and No. 7 and 8 (polished) finishes.
Heat tint or heavy discoloration	Penny-Brite or Copper-Brite	Rub with a dry cloth.	Use in direction of polish lines on No. 4 (polished) finish. May scratch No. 2 (mill) and No. 7 and 8 (polished) finishes.
	Paste NuSteel or DuBois Temp	Rub with dry cloth. Use a small amount of cleaner.	Use in direction of polish lines on No. 4 (polished) finish. May scratch No. 2 (mill) and No. 7 and 8 (polished) finishes.
	Revere Stainless Steel Cleaner	Apply with a damp sponge or cloth.	Use in direction of polish lines on No. 4 (polished) finish. May scratch No. 2 (mill) and No. 7 and 8 (polished) finishes.
	Allen Polish, Steel Bright, Wyandotte, Bab-O or Zud	Rub with a damp cloth.	Use in direction of polish lines on No. 4 (polished) finish. May scratch No. 2 (mill) and No. 7 and 8 (polished) finishes.
Burnt-on foods and grease, fatty acids, milkstone (where swabbing or rubbing is not practical)	Easy-Off, De-Grease-It, 4-6% hot solution of such agents as trisodium triphosphate, or 5-15% caustic soda solution	Apply generous coating. Allow to stand for 10-15 min. Repeated application may be necessary.	Excellent removal, satisfactory for use on all finishes.
Tenacious deposits, rusty discolorations, industrial atmospheric stains	Oakite No. 33, Dilac, Texo 12, Texo N.Y., Flash-Klenz, Caddy Cleaner, Turco Scale 4368 or Permag 57.	Swab and soak with clean cloth. Let stand 15 minutes or more according to directions on package. Rinse and dry.	Satisfactory for use on all finishes.
Hard water spots and scale	Vinegar	Swab or wipe with a cloth. Rinse with water and dry.	Satisfactory for use on all finishes.
	5% oxalic acid, 5% sulamic acid, 5-10% phosphoric acid, or Dilac, Oakite No. 33, Texo 12 or Texo N.Y.	Swab or soak with a cloth. Let stand 10-15 minutes. Always follow with neutralizer rinse, and dry.	Satisfactory for use on all finishes. Effective on tenacious deposits or where scale has built up.
Grease and oil	Organic solvents such as carbon tetrachloride, trichlorethylene, acetone, kerosene, gasoline, benzene, alcohol and chlorethane n.u.	Rub with a cloth. Organic solvents may be flammable and/or toxic. Observe all precautions against fire. Do not smoke while vapors are present. Be sure area is well ventilated.	Satisfactory for use on all finishes.

* Use of proprietary names is intended only to indicate a type of cleaner, and does not constitute an endorsement, nor is omission of any proprietary cleanser to imply its inadequacy. It should be emphasized that all products should be used in strict accordance with instructions on package.

** In all applications a stainless steel wool or sponge or fibrous brush or pad are recommended. Avoid use of ordinary steel wool or steel brushes for scouring stainless steel.

GENERAL INFORMATION

Rear Sliding Door Removal and Installation

The sliding doors come installed from the factory in the door frame. These doors are removable for cleaning and to aid in case maintenance. **NOTE: DO NOT FULLY IMMERSE DOORS WHEN CLEANING.** The inner and outer doors are marked with labels from the factory. If the doors are not labeled, the inner door can be identified as having the limiter stops on it.

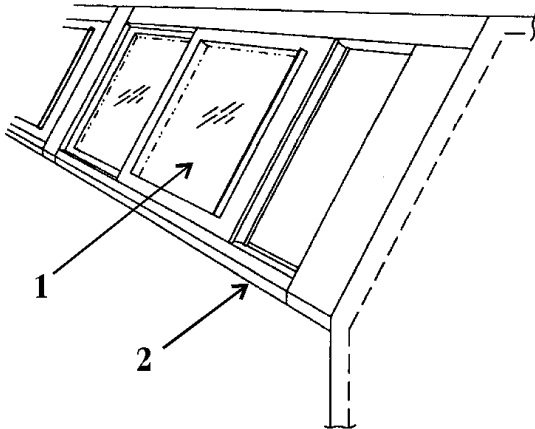

1. Remove the outer door (1) by sliding it to the right end of the door frame (2) (within an inch of being closed).

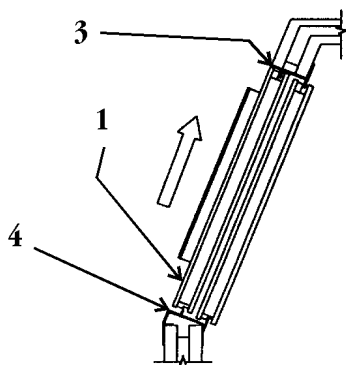

2. Firmly grasp both sides of the outer door (1) and lift into the upper track (3) until it

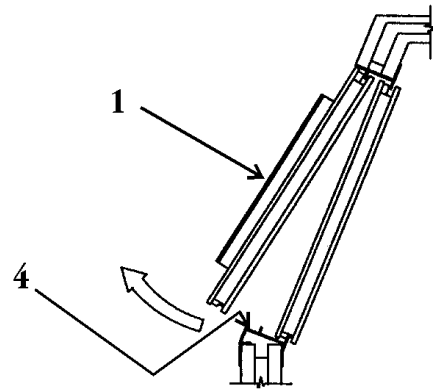

clears the lower track (4).

3. Tilt out the bottom of the outer door (1) so

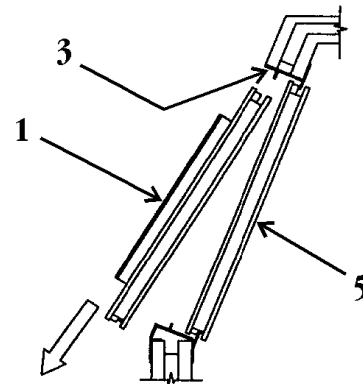

it can clear the lower track (4).

4. Lower the outer door (1) out of the upper track (3) to remove it from the case.
5. Repeat steps 1 thru 4 to remove the inner door (5).
6. Reverse the above steps to replace the inner and outer doors (5 and 1).

Mezzanine Shelving

Mezzanine shelves are available in 10" or 12" widths. One level of shelving is optionally available for LVM and LVF cases, while two levels of shelving is available for LVD cases. The shelves can be moved forward from the mullions in two inch increments and can be

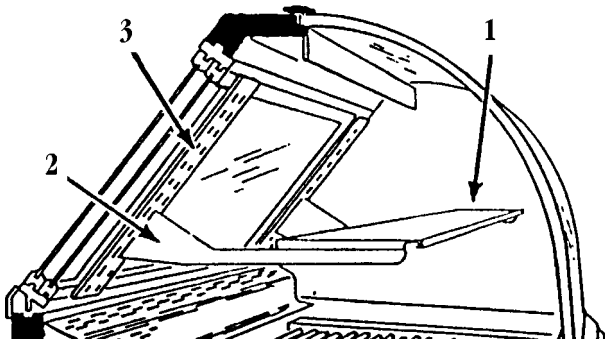

locked into three positions.

To install mezzanine shelving, position and insert the mezzanine shelf (1) and captive shelf brackets (2) into slots in the uprights (3).

NOTE

The brackets can be moved vertically at 1" increments in the uprights.

Lighted Shelves

Lights are optional on the 10" and 12" mezzanine shelves. Wiring harnesses for all shelf locations are factory installed. Ballasts are optionally supplied for all shelf light sockets. The ballasts are located in the electric box on the lower left rear portion of the case, facing rear of case.

Service Case Flush System

Flush systems are offered only on LVF cases to provide a convenient and effective means of maintaining case cleanliness. The system may be operated either manually by a hand valve or automatically using a solenoid and a time clock. The flush water is drained from the case via the normal drain path.

Water is supplied to the system through a pressurized water connection to a domestic water supply. The water is fed to a nozzle array which provides even flushing throughout the case interior. It is recommended to flush cases at least once a day. Flush time

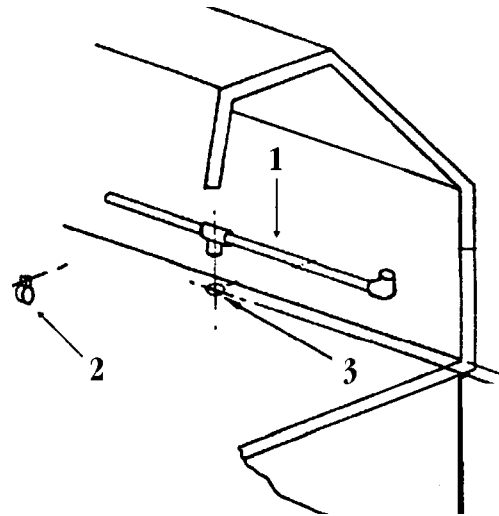

varies depending on the specific case needs.

1. Position the manifold (1) near the rear case wall and secure with manifold anchor clamps (2).
2. Cut a hole in the case well just large enough to connect manifold to 1/2" PVC water supply piping (3).

NOTE

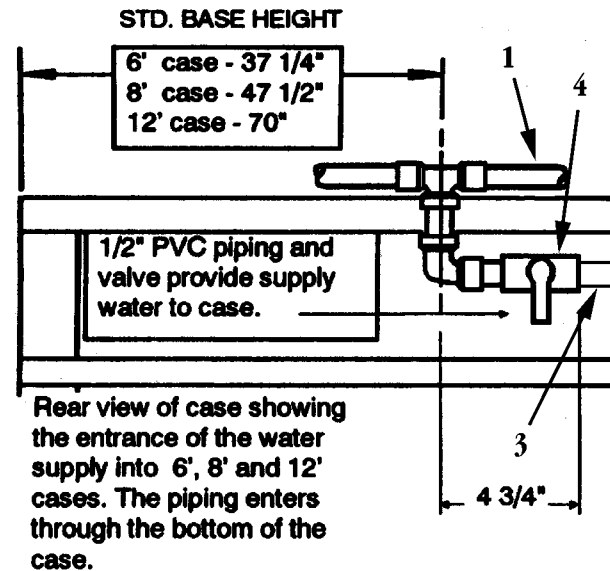

A suitable water supply must be downstream of the isolation valve.

3. Install isolation valve (4) (hand or solenoid) and manifold (1) to water supply piping (3).

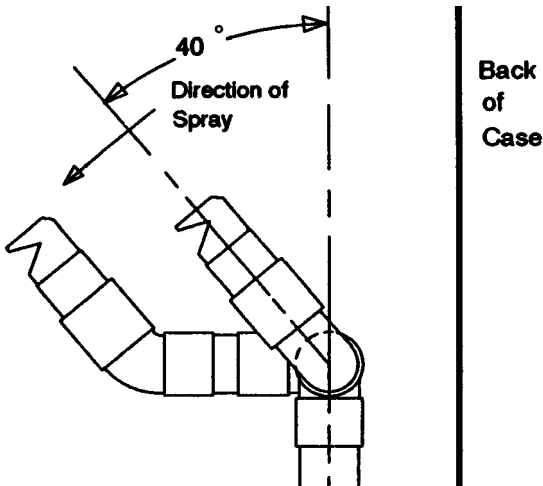

4. Caulk the area where the water supply piping (3) enters the case well to prevent water leakage during system flushing.

Top Mounted Scale Shelf Installation

The optional top scale shelf is mounted to the mullion on the back of the case. The shelf

rests on the flat portion of the top of the case. Use the following instructions to mount the scale shelf assembly.

1. Remove the screws (1) and rear cover (2) from the scale shelf assembly (3).
2. Center the scale shelf assembly (3) on the top rear of the case (4) at the selected mullion (5) location.
3. Loosen wing nut (6) on the front right side of the lower rear support (7) and the two locking capscrews (8) at the rear.
4. Adjust scale shelf (3) to sit level from front-to-rear and side-to-side. When the shelf is level, retighten the wing nut (6) and the two locking capscrews (8).
5. Drill pilot holes in the top two holes in the lower rear support (7), and start top two screws (9). Check for proper shelf alignment, then tighten top two screws (9).
6. Drill pilot holes thru lower two holes in lower rear support (7) and secure with

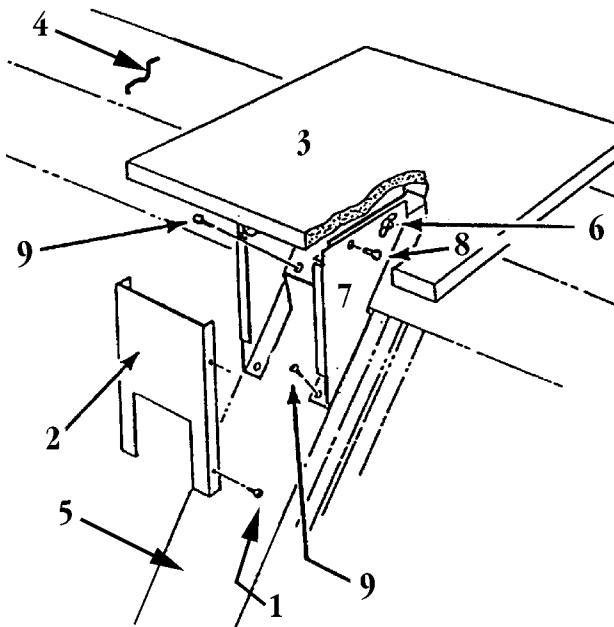

lower two screws (9).

- Replace rear cover (2) and screws (1) on scale shelf assembly (3).

SERVICE INSTRUCTIONS

Light Servicing

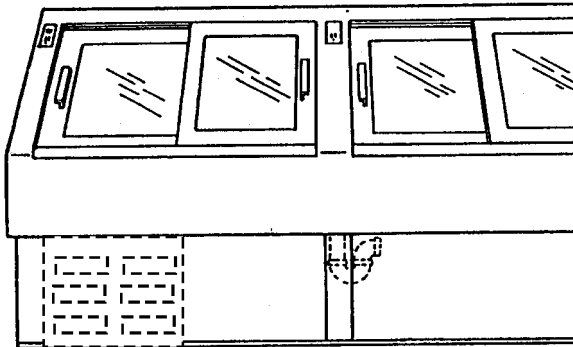

See "General I&S Manual" for T-8 lamp, fan blade and motor (LVD only), and color band and bumper replacement instructions.

Ballast and Lighting Locations

All light ballasts are located in the electric box on the left end of the rear of the case.

In order to retain safety approval with Underwriters Laboratory and the Canadian Standards Association, the mounting of electrical components and interconnecting wires must not deviate from the following instructions. Only qualified personnel are authorized to install the accessory items. TYLER

Refrigeration recommends you order all

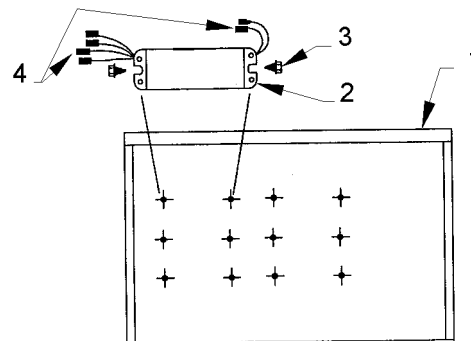

component parts from its Service Parts Department.

Ballast Installation

- Remove cover from electric box (1) located on the left rear side of the case.

NOTE

If tappit screws are not available, a star-washer should be used between the ballast and the heads of the screws.

- Install required number of ballasts (2) in electric box (1) with two screws (3) each.

3. Identify and connect required wiring harnesses (upper, lower, etc...) to the ballast connectors (4).
4. Replace cover on electric box (1).

PARTS INFORMATION

Operational Parts List

Case Usage	Domestic			Export		
	115 Volt 60 Hertz			220 Volt 50 Hertz		
Case Size	6'	8'	12'	6'	8'	12'
Fan Motor (LVD)	5125532 5 Watt	5125532 5 Watt	5125532 5 Watt	5222975 5 Watt	5222975 5 Watt	5222975 5 Watt
Fan Motor Brackets (LVD)	5962269	5962269	5962269	5962269	5962269	5962269
Fan Blades (7" 25° 5B) (LVD)	5236974	5236974	5236974	5236974	5236974	5236974
Rocker Switch	5961377	5961377	5961377	5961377	5961377	5961377
Rectangular Outlet	5236335	5236335	5236335	5236335	5236335	5236335
T-8 Lamp Ballast (canopy)(1-row)	5991029	5991029	5991030	9028437	9028437	9028438
(opt. canopy)(2-row)	5966635	5966635	5991030	9028439	9028439	9028438
(opt. front floor)	5991029	5991029	5991030	9028437	9028437	9028438
(opt. shelf)(per row)	5991029	5991029	5991030	9028437	9028437	9028438
Opt. 800MA Ballast (canopy)	5049140	5049140	5049140	5204859	5204859	5204859
T-8 Lampholder (canopy)	5232279	5232279	5232279	5232279	5232279	5232279
(opt. shelf)	5092414	5092414	5092414	5092414	5092414	5092414
Opt. 800MA Lampholder (telescoping)	5614628	5614628	5614628	5614628	5614628	5614628
(stationary)	5614629	5614629	5614629	5614629	5614629	5614629
Suction Solenoid Valve	5191445	5191445	5191445	5231619	5231619	5231619
Thermostat (LVD)	5193888	5193888	5193888	5193888	5193888	5193888
Electronic Thermostat (LVM/LVF)	5997588	5997588	5997588	5997588	5997588	5997588

Check Valve (LVM) 5199417 5199417 5199417 5199417 5199417
5199417

For information on operational parts not listed above contact the TYLER Service Parts Department.

Cladding and Trim Parts List

<u>Item</u>	<u>Description</u>	<u>6'</u>	<u>8'</u>	<u>12'</u>
1	Screw	5619204(2)	5619204(2)	5619204(2)
2	Top Joint Trim	5239835	5239835	5239835
3	Inner/Outer Glass Joint Trim	5239840(2)	5239840(2)	5239840(2)
4	Tape, Compound	5615115	5615115	5615115
5	Bumper Retainer	9025052	9025058	9025061
6	Screw, Shoulder	9025833(12)	9025833(16)	9025833(24)
7	Color Band, Painted	9025232	9025233	9025234
8	Color Band Backer, Painted	9025979	9025980	9025981
9	Bumper Backer	-----	color per order	-----
10	Bumper	-----	color per order	-----
11	Upr. Frt. Cladding, Painted	9025129	9025130	9025131
12	Rivet	5104702(4)	5104702(5)	5104702(7)
13	Screw, Shoulder	9025833(6)	9025833(10)	9025833(12)
14	Lwr. Frt. Cladding, Painted	9025120	9025121	9025122
15	Kickplate	-----	color per order	-----
16	Screw	5183536(6)	5183536(6)	5183536(8)
17	Kickplate Support	9041329(3)	9041329(3)	9041329(4)
18	Screw, Binding	5100217(3)	5100217(3)	5100217(3)
19	LH End Close-off, Painted	9022468	9022468	9022468
20	RH End Close-off, Painted	9022467	9022467	9022467
21	Horizontal Joint Trim	5961362	5961362	5961362
22	Rear Base Joint Trim	5233638	5233638	5233638
23	Screw	5619204(4)	5619204(4)	5619204(4)
24	Rear Lower Joint Trim	5233635	5233635	5233635
25	Screw	5199134(4)	5199134(4)	5199134(4)

