

SERVICE MANUAL 200/250 TON ELEVATOR/SPIDER



200/250 TON MANUAL ELEVATOR

BVM CORPORATION
430 S. Navajo St.
Denver, CO 80223
Phone: 303-975-1402
Fax: 303-975-0981
E-Mail: sales@bvmcorp.com

200/250 TON - CASING ELEVATOR/SPIDER

TABLE OF CONTENTS

Foreign Spare
Parts.....31

<u>Section No.</u>	<u>Page</u>
I	DESCRIPTION..... 4
	1-1. Introduction..... 4
	1-3. Controls..... 4
	1-4. Specification..... 5
II	INSTALLATION..... 6
	2-1. Components..... 6
	2-2. Installing/Removing Slips..... 6
	2-3. Installing/Removing Guides... .. 7
	2-4. Installing Elevator..... 8
	2-5. Installing Spider..... 9
III	OPERATION..... 10
	3-1. Operation.....10
	3-2. Setting Slips..... 10
	3-3. Raising Slips..... 10
IV	LUBRICATION..... 11
	4-1. Lubrication..... 11
V	MAINTENACE..... 12
	5-1. Preventive Maintenance..... 12
	5-3. Troubleshooting..... 12
VI	DISASSEMBLY & ASSEMBLY..... 13
	6-1. Dissassembly..... 13
	6-2. Assembly..... 13
VII	PARTS LISTS..... 17
	7-1. Parts Lists..... 17
	7-2. 200/250 Ton Spider Assembly..... 19
	7-3. 200/250 Ton Elevator Assembly..... 19
	7-4. 200/250 Ton Elevator/Spider Basic Assembly.....21
	7-5. Beam Lifting Lever Assembly...23
	7-6. Latch Assembly.....24
	7-7. Leveling Beam Assembly.....25
	7-8. Mult-Insert Slip Assembly.....26
	7-9. Double/Single Slip Assembly....28
	7-10. 200/250 Ton Elevator/Spider Slip Assemblies, Guides and Inserts.....30
	7-11. 200/250 Ton Elevator/Spider Accessories.....31
	7-12. 200/250 Ton Elevator/Spider

<u>Section No.</u>	<u>Page</u>
VIII	PNEUMATIC OPERATIONS....35
	8-1. Operations.....33
	8-2. Raising Slips.....33
	8-3. Setting Slips.....33
	8-4. Air Operated Parts Lists....35
	8-5. 200/250 Ton Air Operated Spider Assembly.....35
	8-6. 200/250 Ton Air Operated Elevator Assembly.....36
	8-7. 200/250 Ton Air Operated Elevator/Spider Assy....38
	8-8. Air Operated Latch Assembly.....43
	8-9. Air Operated Leveling Beam Assembly.....44
	8-10. Air Operated Mult-Insert Slip Assembly.....45
	8-11. Air Operated Double/Single Slip Assembly.....45
	8-12. 200/250 Ton Air Operated Elevator/Spider Slip Assemblies, Guides and Inserts.....45
	8-13. 200/250 Ton Air Operated Elevator/Spider Accessories.....45
	8-14. 200/250 Ton Air Operated Elevator/Spider Foreign Spare Parts.....46

LIST OF TABLES

Table No.	Title	Page
1-1.	Specifications.....	5
4-1.	Lubrication Schedule.....	11
5-3.	Troubleshooting.....	12
6-1.	200/250 Ton Spider Assembly.....	14
6-2.	200/250 Ton Elevator Assembly.....	14
6-3.	200/250 Ton Elevator/Spider Assy.....	15
7-2.	200/250 Ton Spider Parts List Index....	18
7-3.	200/250 Ton Elevator Parts List Index....	20
7-4.	200/250 Ton Elevator/Spider Parts List Index.....	22
7-5.	Beam Lifting Lever Parts List Index.....	23
7-6.	Latch Part List Index.....	24
7-7.	Leveling vParts List Index.....	25
7-8.	Multi-Insert Slip Part List Index.....	27
7-9.	Double/Single Slip Part List Index.....	29
7-10.	200/250 Ton Elevator/Spider Slip Assemblies, Guides & Inserts.....	29
7-11.	200/250 Ton Elevator/Spider Accessories.....	31
7-12.	200/250 Ton Elevator/Spider Foreign Spare Parts.....	31
8-2.	200/250 Ton Air Operating Spider Parts List Index.....	35
8-3.	200/250 Ton Air Operating Elevator Parts List Index	37
8-4.	200/250 Ton Air Operating Elevator/Spider Parts List Index.....	41
8-5.	Air Operating Latch Part List Index.....	43
8-6.	Air Operating Leveling Beam Parts List Index.....	45

LIST OF ILLUSTRATIONS

Figure No.	Title	Page
1-1.	Description.....	4
1-2.	Specifications.....	5
2-1.	Components.....	6
2-2.	Slip Detail.....	6
2-3.	Double/Single Inserts.....	7
2-4.	Elevator Guides.....	7
2-5.	Spider Guides.....	7
2-6.	Typical Installation.....	8
2-7.	Standard Derrick Installation.....	8
2-8.	Jackknife Derrick Installation.....	8
2-9.	Spider/Adaptor Plate Installation.....	9
3-1.	Operating Detail.....	10
4-1.	Lubrication Points.....	11
7-2.	200/250 Ton Spider Assembly.....	17
7-3.	200/250 Ton Elevator Assembly.....	19
7-4.	200/250 Ton Elevator/Spider Assy.	21
7-5.	Beam Lifting Lever Assembly.....	23
7-6.	Latch Assembly.....	24
7-7.	Leveling Beam Assembly.....	25
7-8.	Multi-Insert Slips.....	26
7-9.	Double/Single Insert Slips.....	28
8-1.	200/250 Ton Air Operation Details.....	33
8-2.	200/250 Ton Air Operating Spider Assembly.....	34
8-3.	200/250 Ton Air Operating Elevator Assembly.....	36
8-4.	200/250 Ton Air Operating Elevator/Spider Assembly.....	38
8-5.	Air Operating Latch Assembly.....	43
8-6.	Air Operating Leveling Beam Assembly.....	44

SECTION I

DESCRIPTION

INTRODUCTION

1-1. The BVM 200/250 Ton Casing Elevator/Spider can handle ten different casing diameters from 2 3/8 to 7 5/8 inches using four slip assemblies, inserts and proper size guides. The 200/250 ton body can be dressed as a casing elevator or spider, depending on accessories fitted.

1-2. Both configurations consist of four slips mounted on two leveling beams. The leveling beams ride up and down on guide rods and serve to keep the slips in level position and riding simultaneously.

CONTROLS

1-3. Two simple controls make manual operation easy. The slips are easily raised by hand with the 2 ½ foot lever bar provided, requiring no more than 60 pound of force. An optional foot pedal is available for the spider. Slips lock in either the raised, or the set positions.

1. Latch Handle: Operates the locking mechanism. Raise the latch handle and the slips will drop into the bowl by gravity, grip casing and lock. Lower the latch handle to unlock the slips from their set position.

2. Lifting Lever: Fits in socket and is used to raise the slips when force is applied. An optional foot pedal is available to replace the lever when the tool is dressed as a spider.

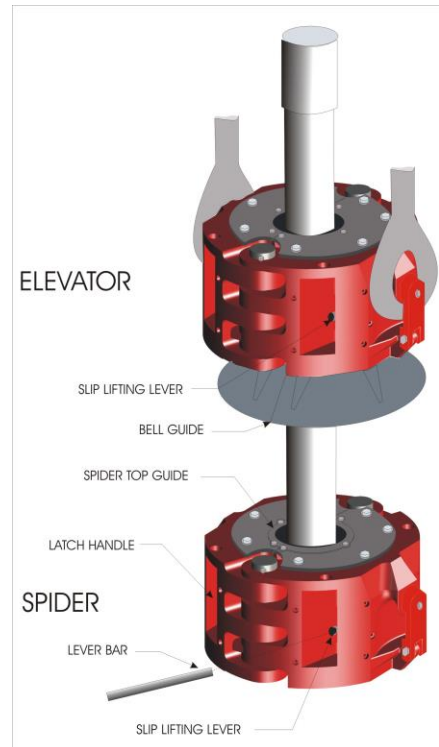

Figure 1-1. Description

1-4. SPECIFICATIONS

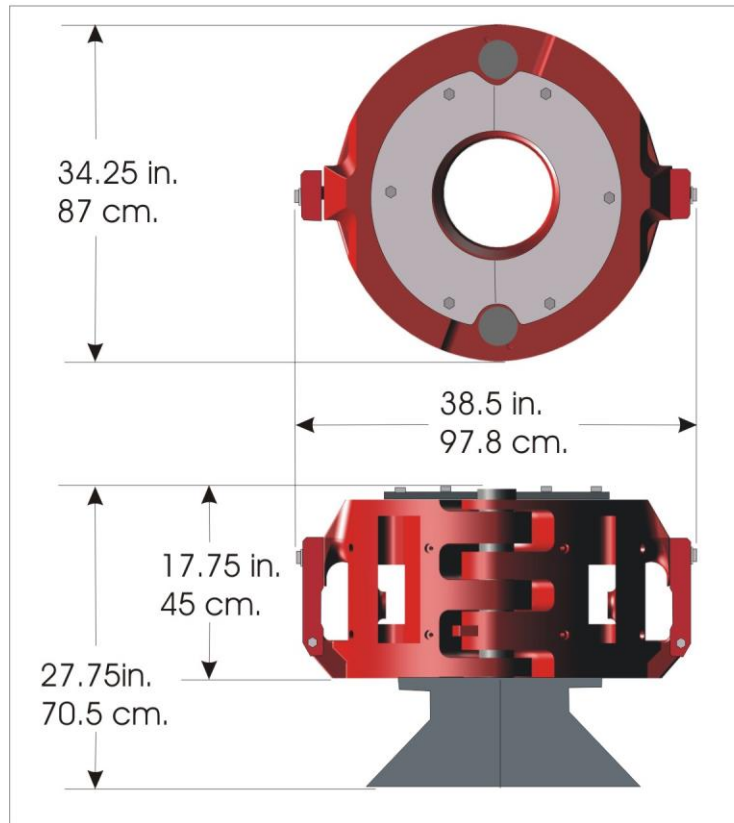

Figure 1-2. Specifications

Table 1-1. Specifications		
Item	English	Metric
Casing Size Range - Diameter	2-3/8 - 7-5/8 in	60.3 - 193.7 mm
Maximum Safe Hook Load Weight	400,000 lb	181,400 kg
Weight, Elevator with Bell Guide (less slips and guides)	2145 lb	975 kg
Weight, Spider (less slips and guides)	1950 lb	900 kg
Spider Adaptor Plate		
Dimensions	38.5 in dia X 2 in	977 mm dia X 50.8 mm
Weight	435 lb	198 kg

SECTION II

INSTALLATION

2-1. COMPONENTS

The 200/250 Ton BVM Casing Elevator/Spider consists of the component illustrated in figure below. Units may be shipped completely assembled with slips and guides of size specified.

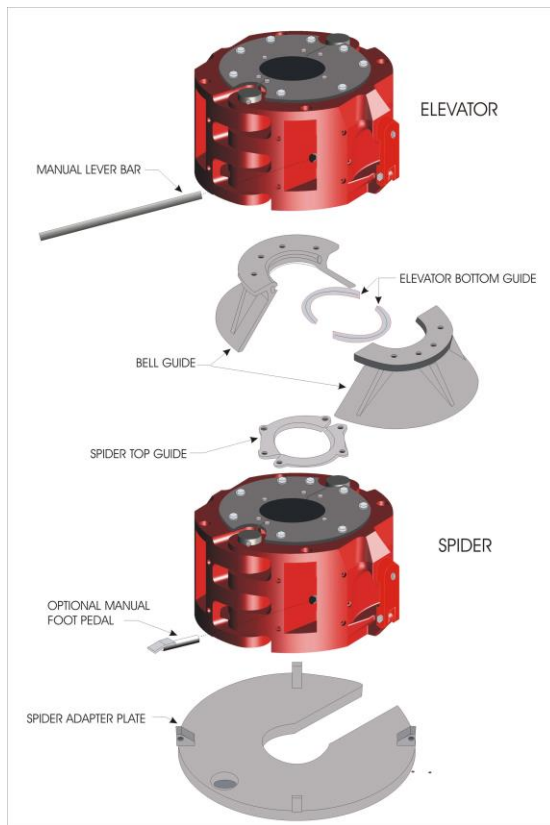

Figure 2-1. Components

2-2. INSTALLING/REMOVING SLIPS

Slip segments are easily installed and removed. Each slip segment is hung in place by hooking to a clevis on the leveling beam, as shown in figure below.

Note

Slip segments for 3 ½ inch and smaller must be installed with double and single insert rows opposite each other. See figure below

To install or remove slips, remove the top cover halves from the top of the body. To remove a slip segment, raise and lock slip assembly, grasp the lifting handle in the slip segment and lift out.

To install a slip segment lower the hook on the back of the slip segment over the clevis on the leveling beam and lower into place. Ensure that the handle drops into the slip segment body. Always be sure back of slip segment and bowl are clean, then apply liberal amount of multipurpose grease to back of slip segment and contact surfaces of bowl before installing slip segments.

CAUTION

Always operate tool with retainer plate installed. Failure to do so could allow slip segments to be pulled up and out of elevator/spider body.

Slips may be installed or removed with body halves open or closed.

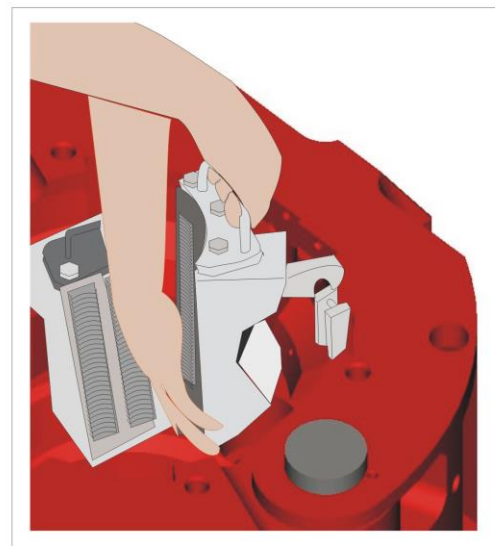

Figure 2-2. Slip Detail

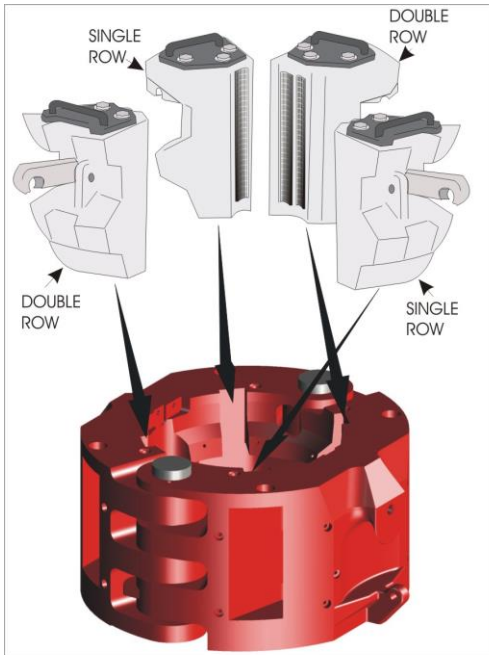

Figure 2-3. Double/Single Inserts

2-3. INSTALLING/REMOVING GUIDES

Elevator guides are installed into a machined groove in the bell guide.

1. Raise body with overhead lift and set over bell guide halves.
2. While still supporting body with lift, align holes, install two, one inch screws and washers per half and tighten fully; then remove lift.
3. Remove removable hinge pin with lift.
4. Spread body halves to provide access.
5. Remove guide retaining bolts and slide elevator guide halves into recess. If guide is inverted it will not seat completely.
6. Install guide retaining bolts and washers.
7. Close elevator body and replace hinge pin.

CAUTION

Always operate elevator with correct guides installed. Failure to do so could cause the casing collar to push the slip segments out of the body from below.

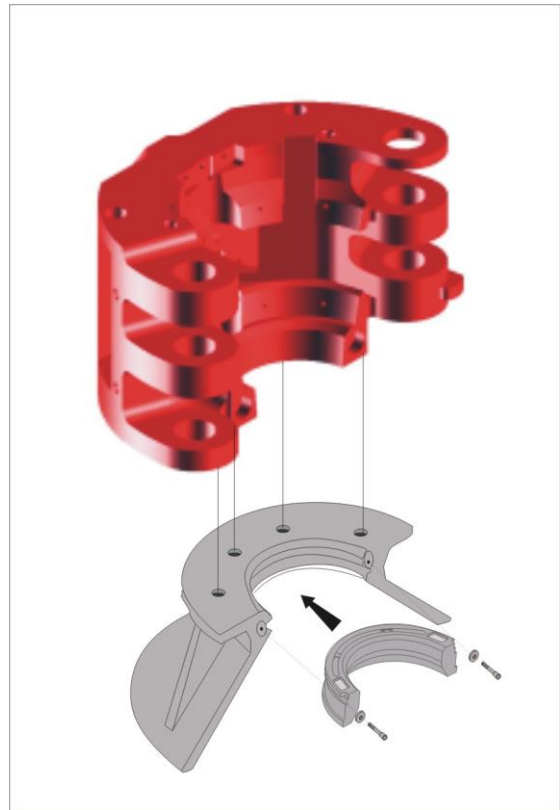

Figure 2-4. Elevator Guides

Spider: Spider guides are installed directly on retainer plate on top of spider

1. Remove $\frac{3}{4}$ inch bolts and lock washers from retainer plate.
2. Install spider guide halves with step in bore of retainer plate.
3. Replace $\frac{3}{4}$ inch bolts and lock washers and tighten snugly.



Figure 2-5. Spider Guides

2-4. INSTALLING ELEVATOR

A typical installation is shown in Figure 2-6.

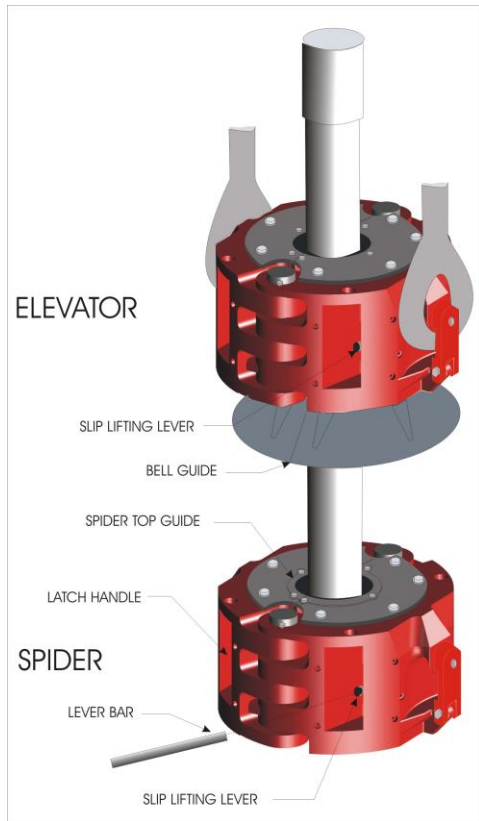

Figure 2-6. Typical Installation

The procedure for connecting cable slings for picking up add-on single joints varies for standard and jackknife derricks. The differences are specified below and shown in Figures 2-7 and 2-8.

1. Lubricate elevator as indicated in Section 4.
2. Attach links to elevator ears as shown in Figure 2-6 and secure link catches.
3. For standard derrick rigs, attach cable slings for picking up add-on single joints to hook of traveling block as indicated in Figure 2-7.
4. For jackknife derrick rigs, attach cable slings for picking up add-on single joints to elevator ears as shown in Figure 2-8.



Figure 2-7. Standard Derrick Installation



Figure 2-8. Jackknife Derrick Installation

1. Lubricate spider as indicated in Section 4.
2. Inside diameter of master bushing is approximately 10 inches. Spider can be set directly on master bushing and rotary table if surface is flat, giving full support to spider.
4. Secure the spider in place over the master bushing. A chain back up will help prevent movement.

CAUTION

The adapter plate used with the spider must have centering blocks around the rim to prevent the spider from sliding off and damaging equipment.

3. A spider adapter plate is required if the top of the rotary table and master bushing are not flat or if there is not sufficient contact surface to fully support the spider. Set the spider directly on the rotary table or on the spider adaptor plate as required.

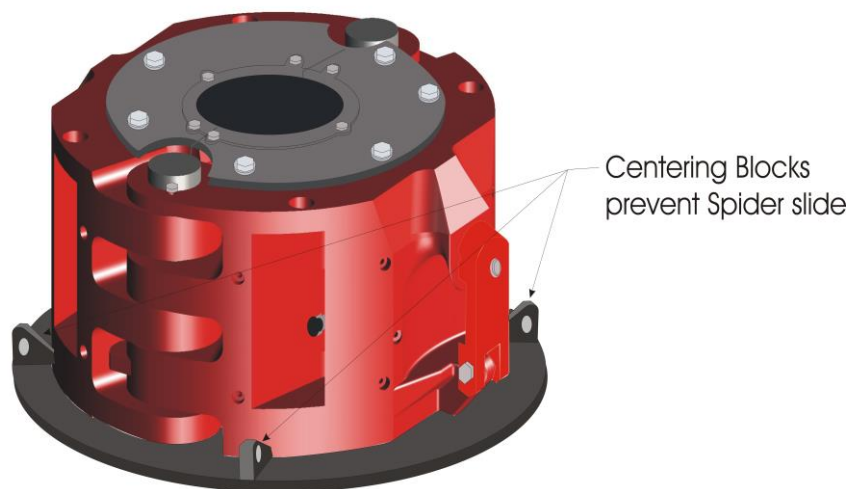

Figure 2-9. Spider/Adapter Plate Installation

SECTION III

OPERATIONS

3-1. OPERATIONS

The elevator and spider operation is controlled by a latch handle and a lifting lever.

3-2. SETTING SLIPS

Raise the latch handle and the slips will drop into the bowl by gravity, grip the casing, and lock. Additional force can be applied to the slips by lifting upward on the lever bar inserted into the lifting lever socket

3-3. RAISING SLIPS

Lower the latch handle, which unlocks the slips from their set position; raise slips by pushing down on the lever bar that is inserted into the lifting lever socket until the slips lock in the up position.

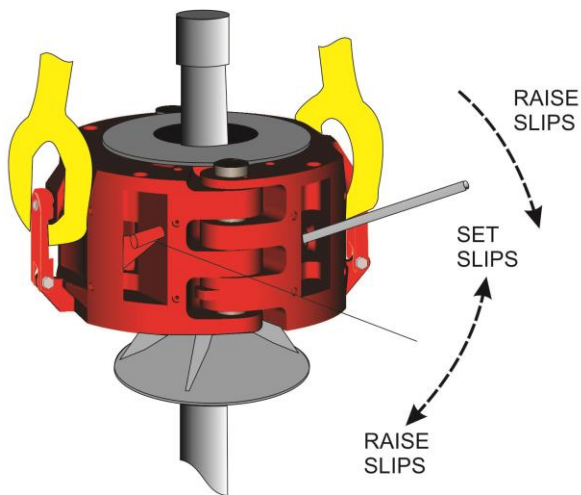

Figure 3-1. Operating Detail

SECTION IV

4-1. LUBRICATION

Proper lubrication of BVM 200/250 ton elevator/spider will help insure long trouble-free operation. The quality of grease used for lubrication is very important.

Recommended grease specifications are:
 NGLI Grade.....2
 Base.....Lithium with 1% minimum Molybdenum disulfide
 Timken O.K. Load.....40 lbs. minimum (ASTM D2509)
 Water Washout..5% maximum at 100 deg. F (ASTM D 1264)

Brand-name greases meeting these specifications include:
 Shell Super Duty Grease, Texaco Molytex EP2, and Mobil Mobilux EP2.

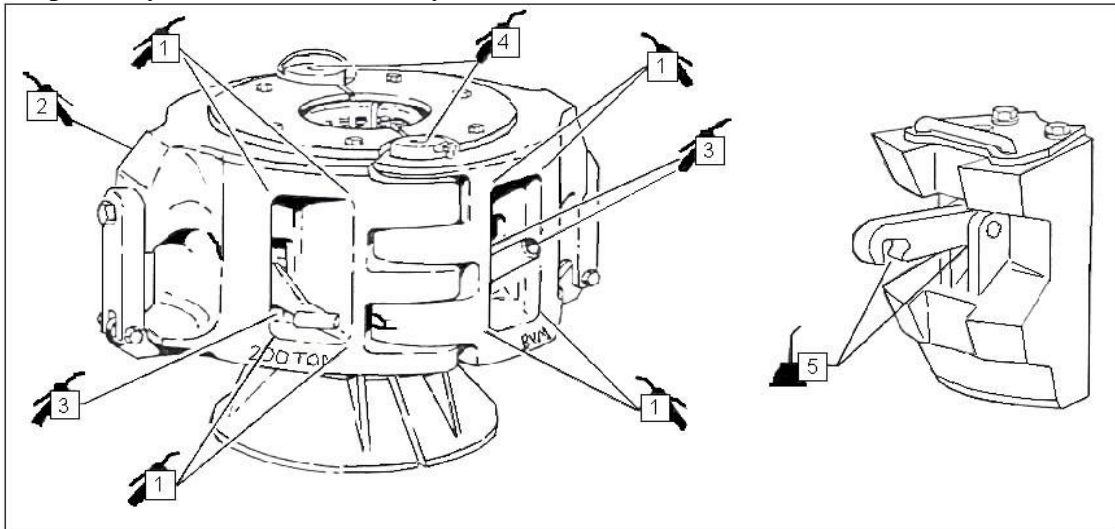

Figure 4-1. Lubrication Points

Table 4-1. Lubrication Schedule				
Ref Fig. 4-1.	Item	No. Lube Points	Application	Lube Cycle
1	Bowl/Slip surfaces	16	Multi-Purpose Moly Waterproof Grease	See NOTE
2	Leveling Beam Guide Rods	2	Multi-Purpose Moly Waterproof Grease	Before each job. See NOTE
3	Lifting Level & Latch	4	Multi-Purpose Moly Waterproof Grease	Before each job. See NOTE
4	Hinge Pin	2	Multi-Purpose Moly Waterproof Grease	Before each job.
5	Leveling Beam Clevises	4	SAE 30 Oil	Weekly

Note

Lubricate elevator and spider, when running dry, every 25 joints of casing and more frequently if necessary to prevent slips from sticking in body. When spider is running wet (mud running over tool), lubricate at least every 5 joints to prevent slips and mechanism from sticking.

When lubricating before job, slips should be in the set position without any casing load on the unit. Lubrication during a casing job may be done with slips in the up position. Leveling beam guide rods should be lubricated in the up position.

SECTION V

MAINTENANCE

5-1. PREVENTIVE MAINTANCE

DO'S

1. Lubricate as required in Table 4-1.
2. Check guides and gripping inserts for wear and replace as required.
3. Avoid unnecessary shock loading of slip segments.

5-3. TROUBLESHOOTING

Table 5-3. Troubleshooting

Symptom	Possible Cause	Remedy
Slip segments do not operate or are difficult to operate in both directions.	Malfunction of lifting lever mechanism.	Inspect lifting lever for dirt, contamination or breakage of components. Clean and replace as necessary.
Lock will not catch when raising slips.	Mud has flowed over tool & gotten into lock and lock slot, preventing it from moving fully outward.	Pump grease through leveling beam guide rod to force mud out.
Slips do not lock in the up or down position.	Latch handle mechanism malfunctions.	Check for dirt, contamination or breakage of components in latch handle mechanism. Clean and replace as necessary.
Pipe slips.	Incorrect slip segments mixed with correct size slips segments.	Install correct size slip segments.
	Worn or re-sharpened inserts.	Replace worn or re-sharpened inserts with new inserts.
	Worn slip segments or inserts allowing slip to set too low in bowl, thereby preventing inserts from gripping pipe.	Inspect slip segments for wear, galling or cracking and inspect bowl for damage. Correct and repair as necessary.
Damaged Pipe.	Incorrect slip segment in slip segment group.	Install correct size slip segments.
	Worn or re-sharpened inserts.	Replace worn or re-sharpened inserts with new inserts.
Slips sticking in bowls.	Inadequate lubrication.	Clean backs of the slip segments and bowl and lubricate properly.
	Galling and pitting of slip segments or bowls.	Redress slips and bowls (should be done by factory but can be done by carefully using a flexible sanding disc and lightly smoothing surface) and protect against corrosion with proper lubrication. Find and correct cause of galling.

DON'TS

1. Never paint over moving parts, backs of slip segments, the inside of the bowl or grease fittings.
2. Never use equipment that is not operating properly.

5-2. Always protect the surface of the backs of the slips and inside of the bowl against corrosion by keeping them clean and well lubricated with multi-purpose waterproof grease.

SECTION VI

DISASSEMBLY & ASSEMBLY

6-1. DISASSEMBLY

Disassembly is presented in Tables 6-1 through 6-3 with the components of the 200/250 Ton Elevator/Spider listed in disassembly sequence. The tables start with a complete assembly and end with a bare body. It is not necessary to start at the beginning and work through the tables for every task. Locate the part to be worked on and start at that point. Notes are provided where applicable to reference or explain a detail for the particular step of disassembly or assembly. When used in the reverse order, the tables provide assembly information as well as disassembly information.

6-2. ASSEMBLY

Assembly of the 200/250 Ton Elevator/Spider can be performed by following the reverse order of Tables 6-1 through 6-3. Notes peculiar to a particular step are provided to highlight critical assembly information such as adjustment or torque values.

Table 6-1. 200/250 Ton Spider Assembly						
Step	Index Fig. #	Part #	1.2.3. Description	Qty per unit	Notes	
					Disassembly	Assembly
	Fig 7-2	79200-1, 3, 5, 7, 9, 11, 13, 15, 17, 19, 21, 23	SPIDER ASSY, 200/250 TON	-		
a.	3, 4, 5	79516-76, 70, 66, 79519-55, 50, 45, 79902-45, 40, 35, 79526-35, 28, 23, 79522-35, 28, 23	* SLIP ASSY	4	Clean	apply multipurpose water resistant grease
b.	1	79200	* ELEVATOR/SPIDER (undressed) (Table 6-3)	1		

Table 6-2. 200/250 Ton Elevator Assembly						
Step	Index Fig. #	Part #	1.2.3. Description	Qty per unit	Notes	
					Disassembly	Assembly
	Fig 7-3	79200-2, 4, 6, 8, 10, 12, 14, 16, 18, 20, 22, 24	ELEVATOR ASSY, 200/250 TON	-		
a.	3, 4, 5	79516-76, 70, 66, 79519-55, 50, 45, 79902-45, 40, 35, 79526-35, 28, 23, 79522-35, 28, 23	* SLIP ASSY	4	Clean	apply multipurpose water resistant grease
b.	6	79111	* GUIDE HALF, Bell	2		
c.	7	79565, 79866, 79867, 79868, 79870, 79869, 79871, 79751	GUIDE SET, Elevator	1		
d.	1	79200	* ELEVATOR/SPIDER (undressed) (Table 6-3)	1		

Table 6-3. 200/250 Ton Elevator/Spider Assembly						
Step	Index Fig. #	Part #	1.2.3. Description	Qty per unit	Notes	
					Disassembly	Assembly
	Fig 7-4	79200	ELEVATOR/SPIDER ASSY (undressed)	Ref.		
a.	17	79803	* CATCH, Link	Ref.		
b.	16	18180-16-5	* SCREW, Shoulder Hex Head	2		
c.	14	79121	* PIN ASSY, Removable Hinge	1	Inspect for wear.	Install new if worn.
d.	15	79124	* PIN ASSY, Stationary Hinge	1		
e.	36	79521	* PLATE, Retainer	2		
f.	32	79126	* BLOCK, Pillow	2		
g.	31	79125	* POST, Leveling Beam Guide	2		
h.	29	79609	* TANG, Leveling beam support	1		
i.	2	79882	* BUTTON, Register	8		
j.	26	79615	* RETAINER, Dog	1		
k.	25	79616	* SPRING, Compression	1		
l.	24	79614	* LATCH, Dog	1		
m.	23	79116	* BEAM ASSY, Leveling	2	Check pins for bending.	
n.	3, Fig. 7-7	79751	* RING, Wiper	2	Discard.	Install new.
o.	2, Fig. 7-7	79728	* BUSHING	2		

Table 6-3 (con't). 200/250 Ton Elevator/Spider Assembly

Step	Index Fig. #	Part #	1.2.3. Description	Qty per unit	Notes	
					Disassembly	Assembly
p.	1, Fig. 7-7	79722	* BEAM ASSEMBLY	1		
q.	9	79585	* PIVOT, Lever	1		
r.	7	79090	* LEVER ASSY, Beam Lifting	1		
s.	2, Fig. 7-5	79681	* FOLLOWER, Cam	1		
t.	1, Fig. 7-5	79136	* BEAM, Lifting	1		
u.	10	79680	* LATCH ASSY	1		
v.	11	79102	* SCREW, Toggle	1		
w.	5, Fig. 7-6	79683	* SPRING BLOCK	1		
x.	6, Fig. 7-6	79682	* SPRING, Compression	1		
w.	12, Fig. 7-6	79604-7-S	* PIN, Spring	1		Install new.
z.	4, Fig. 7-6	79684	* CLEVIS, Toggle	1		
aa.	2, Fig. 7-6	79127	* HANDLE, Latch	1		
ab.	1, Fig. 7-6	79679	* BASE ASSY, Latch	1		
ac.	1	79109	* BODY	1	Check for Scoring.	Install new if damaged.

SECTION VII

PARTS LIST

7-1. PARTS LIST

The parts lists in this section reflect part numbers and quantities used in the 200/250 Ton

Elevator/Spider. The quantity per unit column is the total number of parts for the 200/250 Ton Elevator/Spider.

The parts list uses the indentation method to show component subassembly relationships. Items listed one column to the right under assembly is detailed parts of that assembly.

7-2. 200/250 TON SPIDER ASSEMBLY

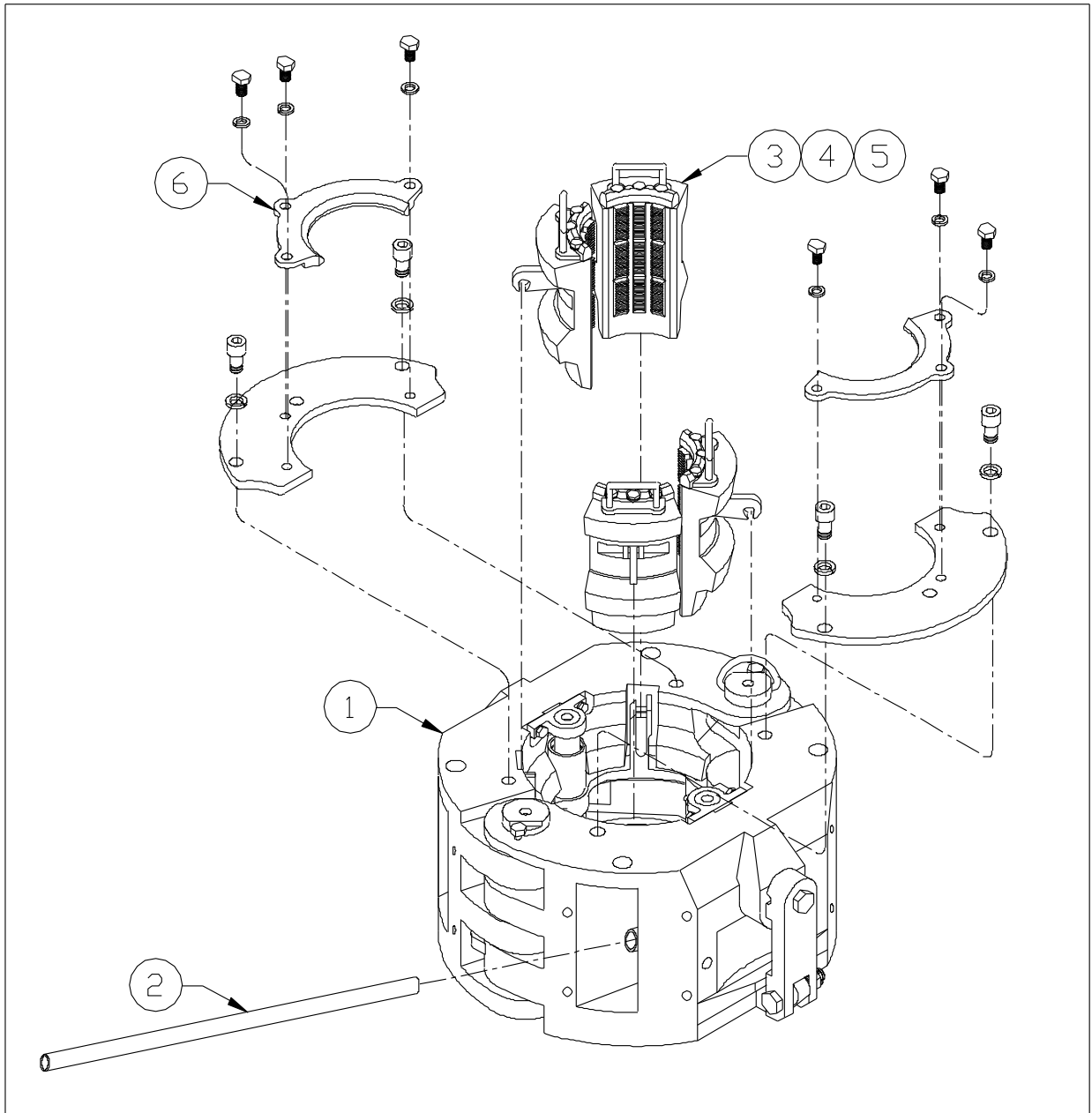

Figure 7-2. 200/250 Ton Spider Assembly

Table 7-2. 200/250 Ton Spider Parts List Index

200 TON SPIDER ASSEMBLY																
ITEM NO.	IN-DENT	PART NAME	7-5/8"			5-1/2"			4-1/2"			3-1/2"			QTY	REMARKS
			7 5/8"	7"	6-5/8"	5-1/2"	5"	4-1/2"	4-1/2"	4"	3-1/2"	3-1/2"	2-7/8"	2-3/8"		
-	0	200/250 TON SPIDER ASSY	79200-1	79200-3	79200-5	79200-7	79200-9	79200-11	79200-13	79200-15	79200-17	79200-19	79200-21	79200-23	REF	
1	1	ELEVATOR/SPIDER (undressed)	79200	79200	79200	79200	79200	79200	79200	79200	79200	79200	79200	79200	1	Fig. 7-4 for breakdown
2	1	LEVER HANDLE	79588	79588	79588	79588	79588	79588	79588	79588	79588	79588	79588	79588	1	
3	1	SLIP ASSY	79516-76	79516-70	79516-66	79519-55	79519-50	79519-45	79902-45	79902-40	79902-35	-	-	-	4	Fig. 7-8 for breakdown
4	1	SLIP ASSY, SINGLE	-	-	-	-	-	-	-	-	-	79522-35	79522-28	79522-23	2	Fig. 7-9 for breakdown
5	1	SLIP ASSY, DOUBLE	-	-	-	-	-	-	-	-	-	79526-35	79526-28	79526-23	2	Fig. 7-9 for breakdown
6	1	SPIDER GUIDE SET	79858	79859	79859	79860	79860	79861	79861	79862	79863	79863	79864	79525	1	Refer to Fig. 7-3 for attaching pairs

7-3. 200/250 TON ELEVATOR ASSEMBLY

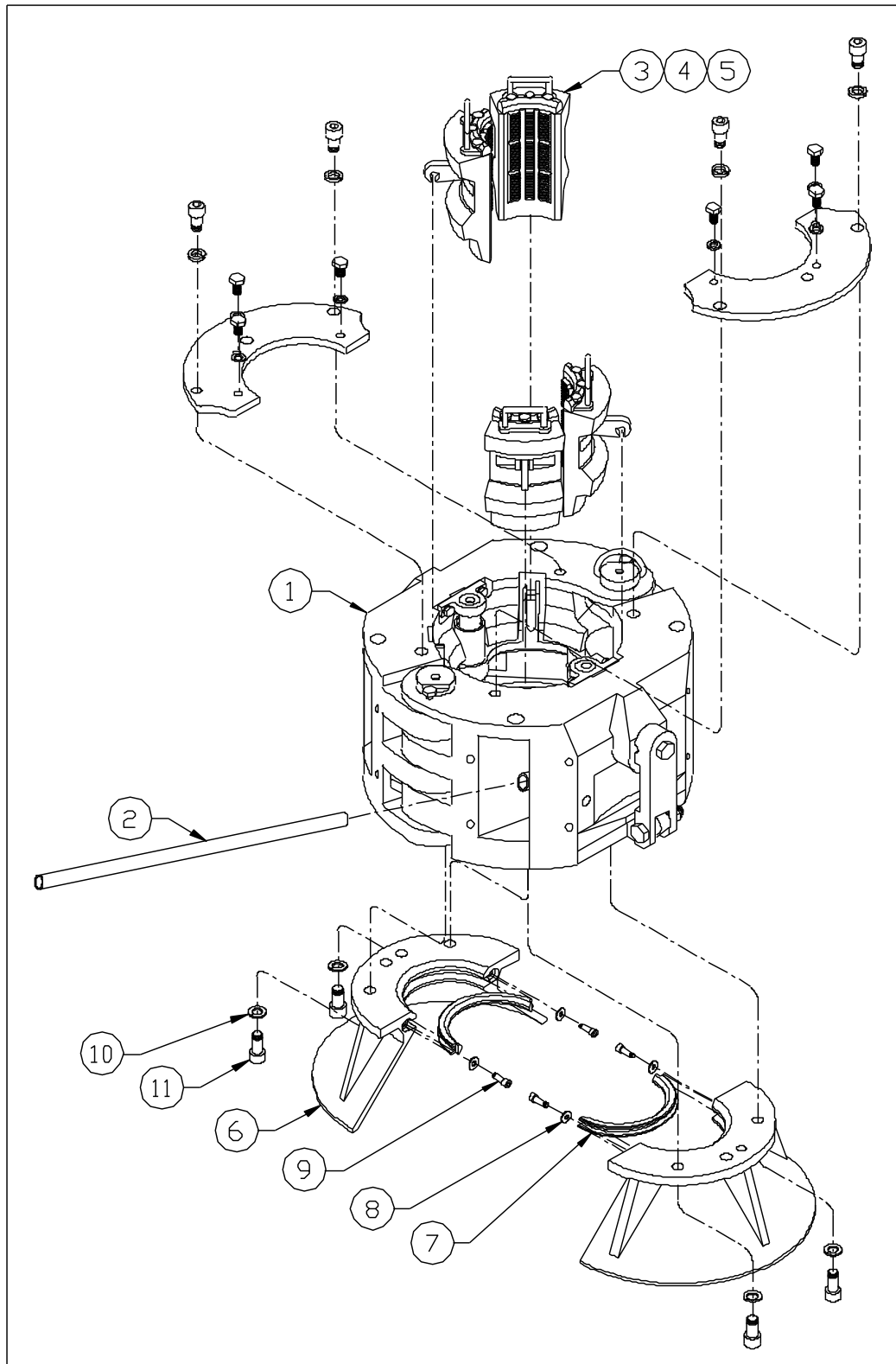

Figure 7-3. 200/250 Ton Elevator Assembly

Table 7-3. 200/250 Ton Elevator Parts List Index

200 TON ELEVATOR ASSEMBLY																
ITEM NO.	IN-DENT	PART NAME	7-5/8"			5-1/2"			4-1/2"			3-1/2"			QTY	REMARKS
			7 5/8"	7"	6-5/8"	5-1/2"	5"	4-1/2"	4-1/2"	4"	3-1/2"	3-1/2"	3-1/2"	2-7/8"		
-	0	200/250 TON SPIDER ASSY	79200-2	79200-4	79200-6	79200-8	79200-10	79200-12	79200-14	79200-16	79200-18	79200-20	79200-22	79200-24	REF	
1	1	ELEVATOR/SPIDER (undressed)	79200	79200	79200	79200	79200	79200	79200	79200	79200	79200	79200	79200	1	Fig. 7-4 for breakdown
2	1	LEVER HANDLE	79588	79588	79588	79588	79588	79588	79588	79588	79588	79588	79588	79588	1	
3	1	SLIP ASSY	79516-76	79516-70	79516-66	79519-55	79519-50	79519-45	79902-45	79902-40	79902-35	-	-	-	4	Fig. 7-8 for breakdown
4	1	SLIP ASSY, SINGLE	-	-	-	-	-	-	-	-	-	79522-35	79522-28	79522-23	2	Fig. 7-9 for breakdown
5	1	SLIP ASSY, DOUBLE	-	-	-	-	-	-	-	-	-	79526-35	79526-28	79526-23	2	Fig. 7-9 for breakdown
6	1	BELL GUIDE, HALF	79111	79111	79111	79111	79111	79111	79111	79111	79111	79111	79111	79111	1	For repl. Order 79772
7	1	ELEVATOR GUIDE, SET	79865	79866	79866	79867	79867	79868	79868	79869	79870	79870	79871	79751	1	
8	1	WASHER, FENDER	24080-00-0	24080-00-0	24080-00-0	24080-00-0	24080-00-0	24080-00-0	24080-00-0	24080-00-0	24080-00-0	24080-00-0	24080-00-0	24080-00-0	4	
9	1	SCREW, BUTTON HEAD CAP	1608C-06-5	1608C-06-5	1608C-06-5	1608C-06-5	1608C-06-5	1608C-06-5	1608C-06-5	1608C-06-5	1608C-06-5	1608C-06-5	1608C-06-5	1608C-06-5	4	
10	1	LOCKWASHER	20160-00-0	20160-00-0	20160-00-0	20160-00-0	20160-00-0	20160-00-0	20160-00-0	20160-00-0	20160-00-0	20160-00-0	20160-00-0	20160-00-0	4	
11	1	SCREW, CAP HEX HEAD	1416C-16-5	1416C-16-5	1416C-16-5	1416C-16-5	1416C-16-5	1416C-16-5	1416C-16-5	1416C-16-5	1416C-16-5	1416C-16-5	1416C-16-5	1416C-16-5	4	

7-4. 200/250 TON ELEVATOR/SPIDER BASIC ASSEMBLY

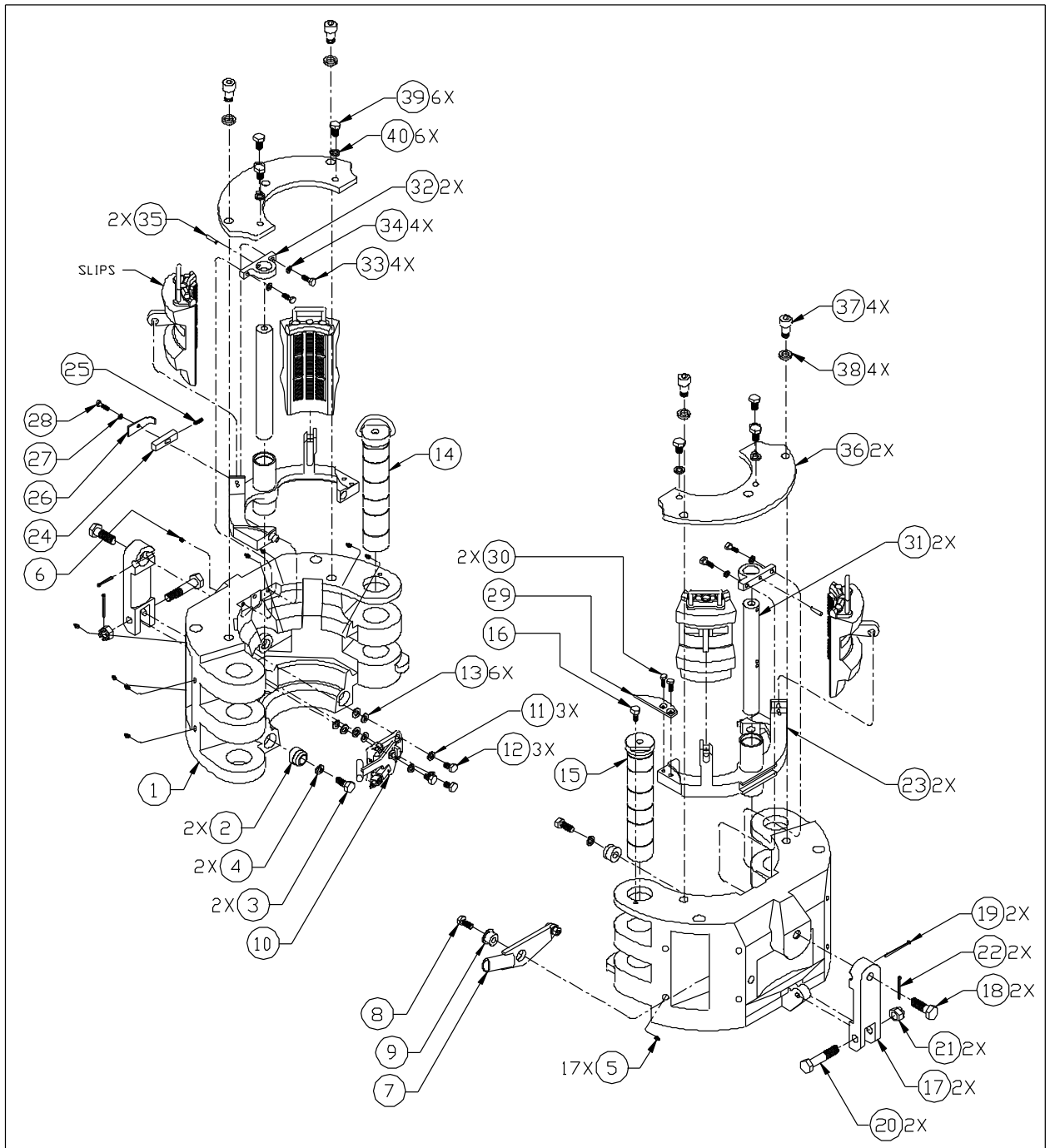

Figure 7-4. 200/250 Ton Elevator/Spider Assembly

Table 7-4. 200/250 Ton Elevator/Spider Parts List Index

ITEM #	BVM Corp PART #	1.2.3. DESCRIPTION	QTY/ UNIT
	79200	ELEVATOR/SPIDER ASSY, 200/250 Ton Basic.....	Ref.
1	79109-1	BODY.....	1
2	79882	BUTTON, Register.....	2
3	1212C-16-8	SCREW, Socket Head.....	2
5	940308-1	FITTING, Grease.....	17
6	79001-12-C	PLUG, Pipe.....	1
7	79090	LEVER ASSY, Beam Lifting (see Fig. 7-5 for breakdown).....	1
8	1410C-14-5	SCREW, Cap Hex Head.....	1
9	79585	PIVOT, Lever.....	1
10	79680	LATCH ASSY (see Fig. 7-6 for breakdown).....	1
11	20100-00-0	LOCKWASHER.....	3
12	1410C-10-5	SCREW, Cap Hex Head.....	3
13	28100-00-0	WASHER, Flat.....	6
14	79121	PIN ASSY, Removable Hinge.....	1
15	79124	PIN ASSY, Stationary Hinge.....	1
16	79610	SCREW, Shoulder Hex Head.....	1
17	79803	CATCH LINK.....	2
18	79805	SCREW, Upper Link Block.....	2
19	30040-24-0	PIN, Cotter.....	2
20	79261	SCREW, Lower Link Block.....	2
21	6816C-00-5	NUT, Castle.....	2
22	30040-16-0	PIN, Cotter.....	2
23	79116	BEAM ASSY, Leveling (see Fig. 7-7 for breakdown)....	2
24	79614	LATCH, Dog.....	1
25	79616	SPRING, Compression (for replacement order 79141)....	1
26	79615	RETAINER, Dog (for replacement order 79141).....	1
27	20060-00-0	LOCKWASHER.....	1
28	1406C-12-5	SCREW, Cap Hex Head.....	1
29	79609	TANG, Leveling Beam Support (for replacement order 79518).....	1
30	2208C-10-5	SCREW, Flat Head.....	2
31	79125	POST, Leveling Beam Guide.....	2
32	79126	BLOCK, Pillow (for replacement order 79520).....	2
33	1208C-12-8	SCREW, Socket Head.....	4
34	20080-00-0	LOCKWASHER.....	4
35	79606-3	PIN, Pillow Block.....	2
36	79521	PLATE, Top.....	2
37	1416C-18-5	SCREW, Cap Hex Head.....	4
38	20160-00-0	LOCKWASHER.....	4
39	1412F-10-5	SCREW, Cap Hex Head.....	6
40	20120-00-0	LOCKWASHER.....	6

7-5. BEAM LIFTING LEVER ASSEMBLY

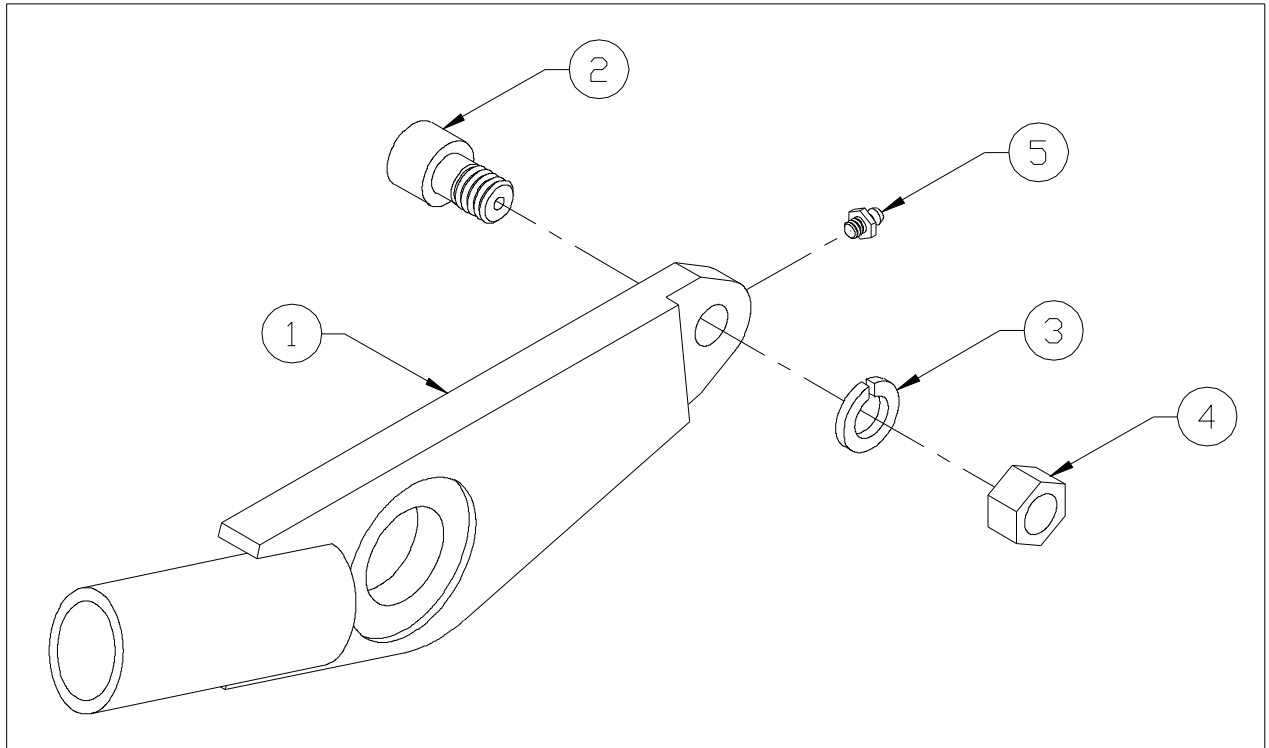

Figure 7-5. Beam Lifting Lever Assembly

Table 7-5. Beam Lifting Lever Parts List Index

BVM Corp			QTY/ UNIT
ITEM #	PART #	1.2.3. DESCRIPTION	
	79090	LEVER ASSY, Bear lifting (see Fig. 7-4 for NHA).....	Ref.
1	79136	LEVER, Lifting.....	1
2	79681	FOLLOWER, Cam.....	1
3	20100-00-0	LOCKWASHER.....	1
4	6010F-00-0	NUT, Hex.....	1
5	79208	FITTING, Grease.....	1

7-6. LATCH ASSEMBLY

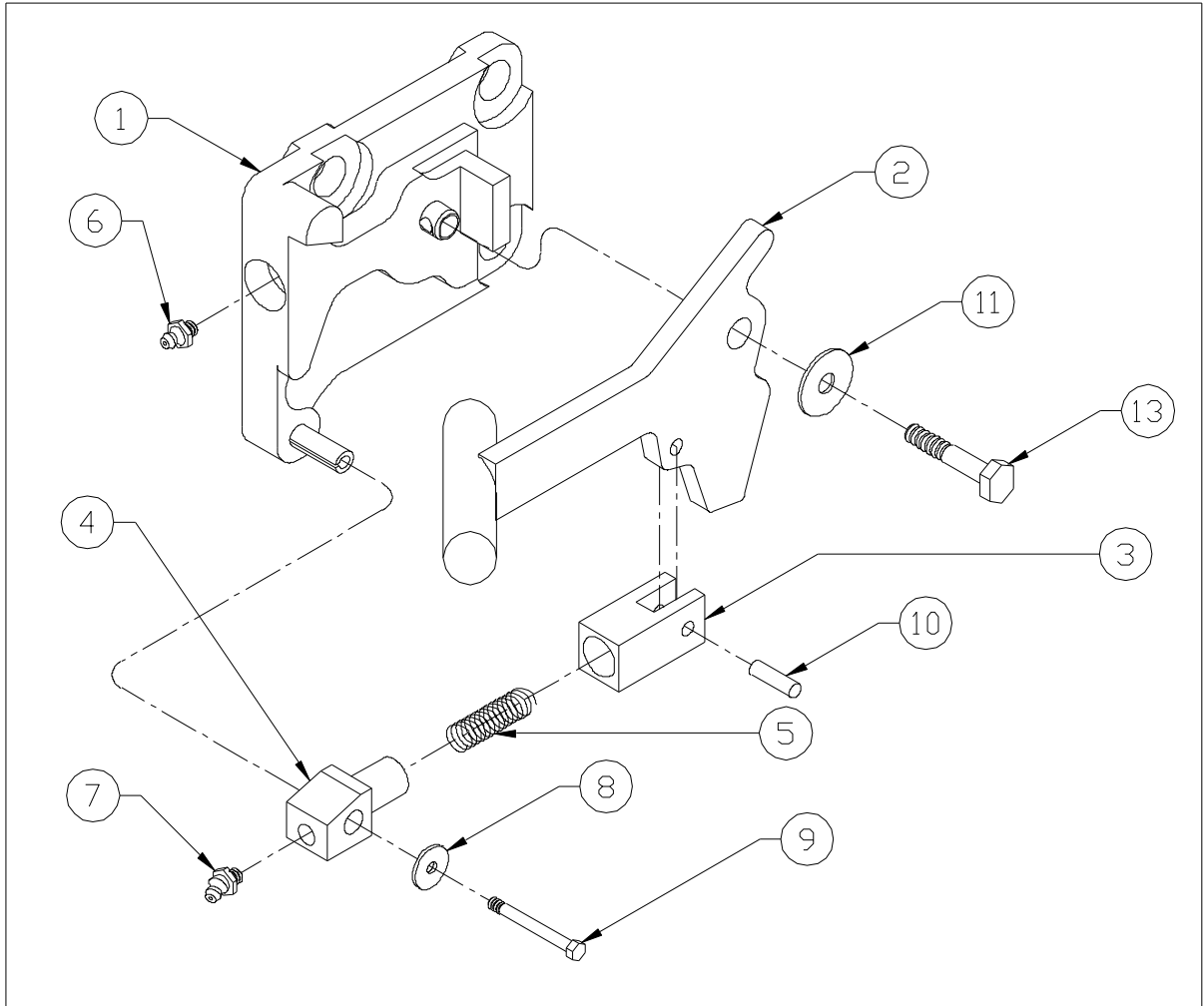

Figure 7-6. Latch Assembly

Table 7-6. Latch Parts List Index

ITEM #	PART #	1.2.3. DESCRIPTION	QTY/ UNIT
	79680	LATCH ASSY (see Fig. 7-4 for NHA).....	Ref.
1	79679	BASE ASSY, Latch.....	1
2	79127	HANDLE ASSEMBLY, Latch.....	1
3	79684	CLEVIS, Toggle.....	1
4	79683	SPRING BLOCK.....	1
5	79682	SPRING, Compression.....	1
6	940308-1	FITTING, Grease.....	1
7	79202	FITTING, Grease.....	1
8	220J0-00-0	WASHER, Flat.....	1
9	120JF-14-5	SCREW, Socket Head.....	1
10	40040-06-0	PIN, Roll.....	1
11	22050-00-0	WASHER, Flat.....	1
12	1405C-14-5	SCREW, Cap Hex Head.....	1

7-7. LEVELING BEAM ASSEMBLY

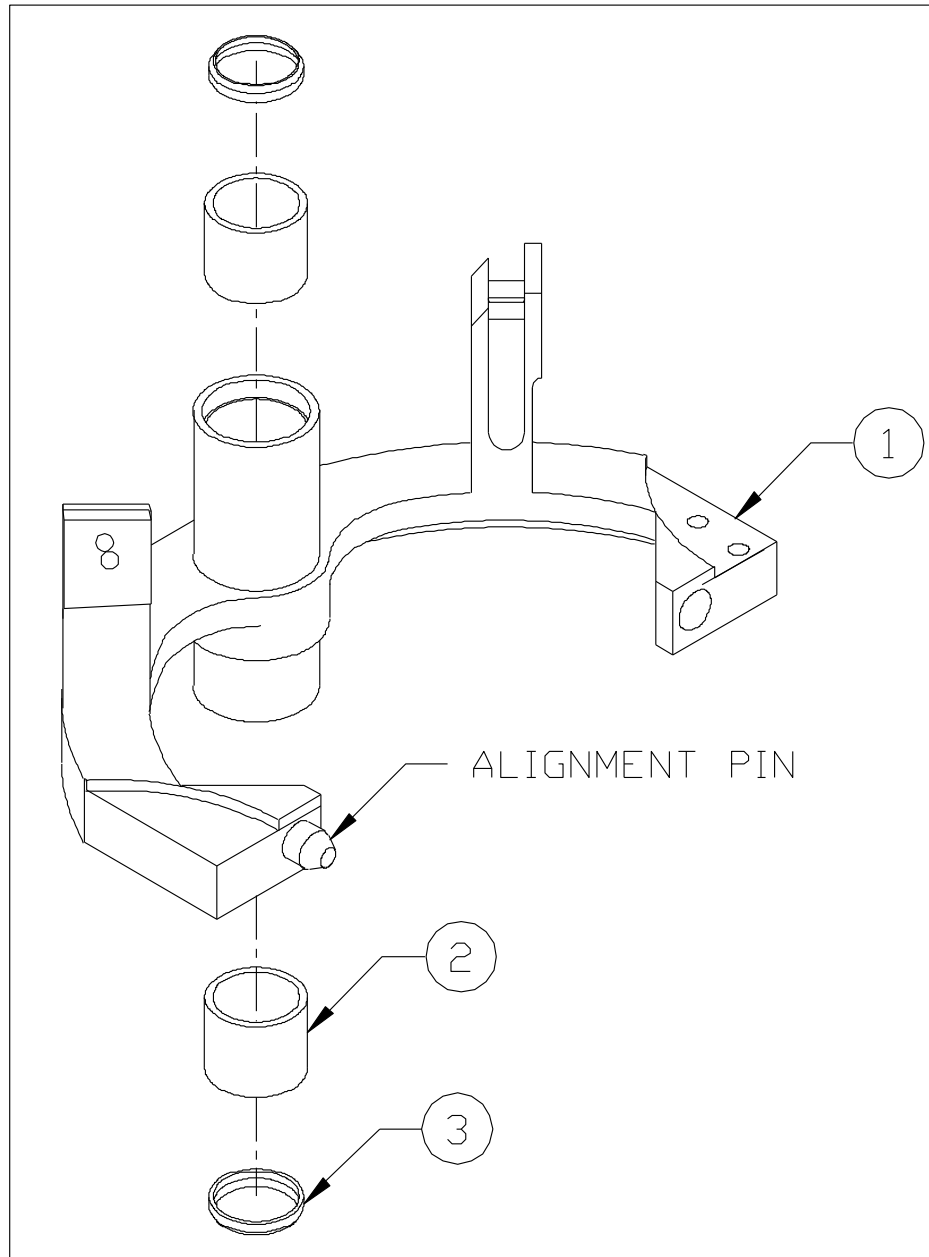

Figure 7-7. Leveling Beam Assembly

Table 7-7. Leveling Beam Parts List Index

ITEM #	BVM Corp PART #	1.2.3. DESCRIPTION	QTY/ UNIT
	79116-1	BEAM ASSY, Leveling (see Fig. 7-4 for NHA).....	Ref.
1	79722	BEAM (Casting only).....	1
-	79722-1	ALIGNMENT PIN.....	-
2	79728	BUSHING.....	2
3	79752	RING, Wiper.....	2

7-8. MULTI-INSERT SLIP ASSEMBLY

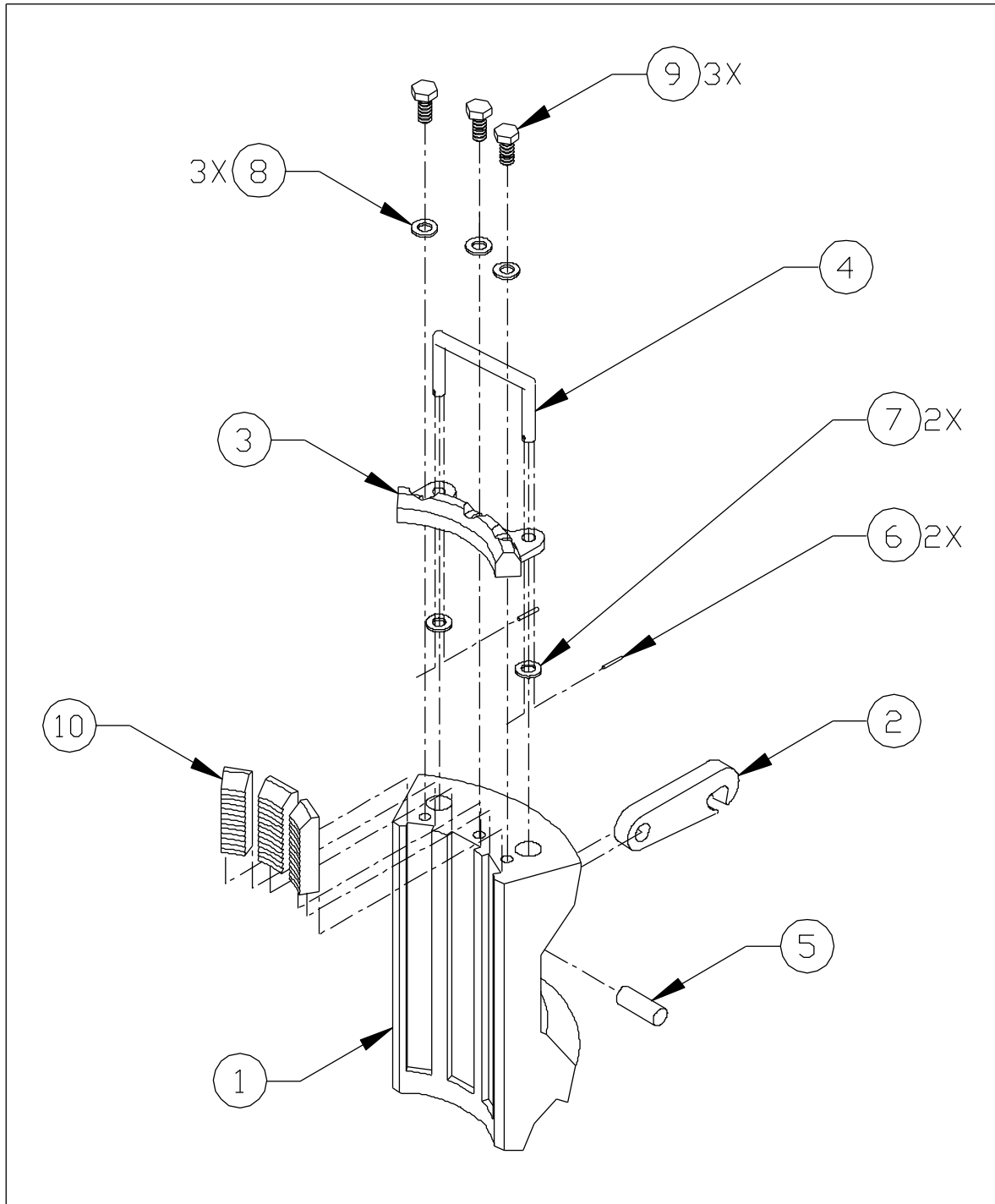

Figure 7-8. Multi-Insert Slips

Table 7-8. Multi-Insert Slip Part List Index

200 TON SLIP ASSEMBLY													
ITEM NO.	IN-DENT	PART NAME	7-5/8"			5-1/2"			4-1/2"			QTY	REMARKS
			7 5/8"	7"	6-5/8"	5-1/2"	5"	4-1/2"	4-1/2"	4"	3-1/2"		
-	0	SLIP ASSY	79516-76	79516-70	79516-66	79519-55	79519-50	79519-45	79902-45	79902-40	79902-35	REF	FIGURES 1 & 2 for NHA
1	1	SLIP SEGMENT	79512	79512	79512	79513	79513	79513	79903	79903	79903	1	
2	1	SLIP HOOK	79528	79528	79528	79529	79529	79529	79529	79529	79529	1	
3	1	RETAINER PLATE	79530 (A)	79530 (A)	79530 (A)	79531 (B)	79531 (B)	79531 (B)	79609 (C)	79609 (C)	79609 (C)	4	For repl. Order (A) 79142 (B) 79143 (C) 79144
4	1	SLIP HANDLE	79511	79511	79511	79511	79511	79511	79511	79511	79511	1	For repl. Order 79146
5	1	PIN, ROLL	79534	79534	79534	79534	79534	79534	79534	79534	79534	1	
6	1	PIN, ROLL	79602-5-S	79602-5-S	79602-5-S	79602-5-S	79602-5-S	79602-5-S	79602-5-S	79602-5-S	79602-5-S	2	
7	1	WASHER, FLAT	22080-00-0	22080-00-0	22080-00-0	22080-00-0	22080-00-0	22080-00-0	22080-00-0	22080-00-0	22080-00-0	2	
8	1	LOCKWASHER	20080-00-0	20080-00-0	20080-00-0	20080-00-0	20080-00-0	20080-00-0	20080-00-0	20080-00-0	20080-00-0	3	
9	1	SCREW, CAP HEX HEAD	1408C-12-5	1408C-12-5	1408C-12-5	1408C-12-5	1408C-12-5	1408C-12-5	1408C-12-5	1408C-12-5	1408C-12-5	3	
10	1	INSERTS	2633	-	-	-	-	-	-	-	-	12	
10	1	INSERTS	-	2623	2632	-	-	-	-	-	-	6	
10	1	INSERTS, BEVELED	-	2623B	2632B	-	-	-	-	-	-	6	
10	1	INSERTS	-	-	-	2170	-	-	2165	-	-	8	
10	1	INSERTS	-	-	-	-	2169	2168	-	2164	2163	4	
10	1	INSERTS, BEVELED	-	-	-	-	2169B	2168B	-	2164B	2163B	4	

7-9. DOUBLE/SINGLE SLIP ASSEMBLY

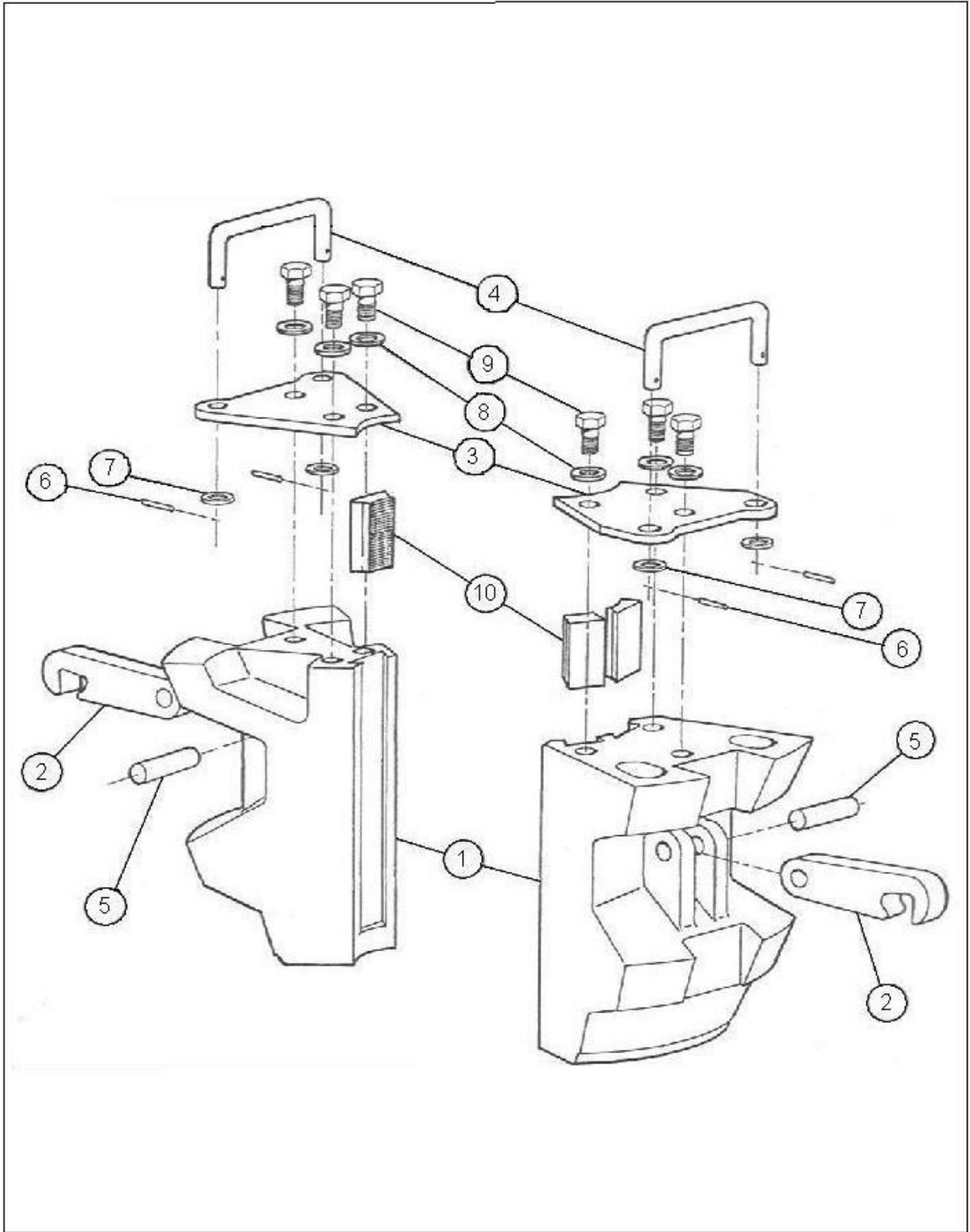

Figure 7-9. Double/Single Insert Slips

Table 7-9. Double/Single Slip Part List Index

200 TON SLIP ASSEMBLY												
ITEM NO.	IN-DENT	PART NAME	3-1/2" DOUBLE			QTY	REMARKS	3-1/2" SINGLE			QTY	REMARKS
			3-1/2"	2-7/8"	2-3/8"			3-1/2"	2-7/8"	2-3/8"		
-	0	SLIP ASSY	79526-35	79526-28	79526-23	REF	FIG 7.2 & 7.3 for NHA	79522-35	79522-28	79522-23	REF	FIG 7.2 & 7.3 for NHA
1	1	SLIP SEGMENT	79515	79515	79515	1		79514	79514	79514	1	
2	1	SLIP HOOK	79529	79529	79529	1		79529	79529	79529	1	
3	1	RETAINER PLATE	79533	79533	79533	4		79532	79532	79532	4	For repl. Order 79114
4	1	SLIP HANDLE	79511D	79511D	79511D	1	For repl. Order 79145	79511S	79511S	79511S	1	For repl. Order 79146
5	1	PIN, ROLL	79534	79534	79534	1		79534	79534	79534	1	
6	1	PIN, ROLL	79602-5-S	79602-5-S	79602-5-S	2		79602-5-S	79602-5-S	79602-5-S	2	
7	1	WASHER, FLAT	22080-00-0	22080-00-0	22080-00-0	2		22080-00-0	22080-00-0	22080-00-0	2	
8	1	LOCKWASHER	20080-00-0	20080-00-0	20080-00-0	3		20080-00-0	20080-00-0	20080-00-0	3	
9	1	SCREW, CAP HEX HEAD	1408C-12-5	1408C-12-5	1408C-12-5	3		1408C-12-5	1408C-12-5	1408C-12-5	3	
10	1	INSERTS	2162	-	-	8		2162	-	-	4	
10	1	INSERTS	-	2161	2160	4		-	2161	2160	2	
10	1	INSERTS, BEVELED	-	2161B	2160B	4		-	2161B	2160B	2	

7-10. 200/250 TON ELEVATOR/SPIDER SLIP ASSEMBLIES, GUIDES AND INSERTS

Table 7-10. 200/250 Ton Elevator/Spider Slip Assemblies, Guides and Inserts

SLIPS	SLIP BODY	7-5/8"			5-1/2"			4-1/2"			3-1/2"			
	SLIP SIZE	7-5/8"	7"	6-5/8"	5-1/2"	5"	4-1/2"	4-1/2"	4"	3-1/2"	3-1/2"	2-7/8"	2-3/8"	
	PART NUMBERS													
	SLIP ASSYS, COMPLETE WITH INSERTS	79524-76	79524-70	79524-66	79525-55	79525-50	79525-45	79901-45	79901-40	79901-35	79527-35	79527-28	79527-23	
GUIDES	ELEVATOR	79865	79866	79866	79867	79867	79868	79868	79869	79870	79870	79871	79521	
	SPIDER	79858	79859	79859	79860	79860	79861	79861	79862	79863	79863	79864	79528	
	GUIDE I.D.'s													
	ELEVATOR	9.04"	9.04"	8.60"	7.40"	7.40"	6.10"	6.10"	6.10"	5.14"	5.14"	4.47"	3.50"	
	SPIDER	9.04"	9.04"	8.60"	7.40"	7.40"	6.10"	6.10"	6.10"	5.14"	5.14"	4.47"	3.50"	
INSERTS	PART NUMBERS													
	48 PER UNIT	2633-48	-	-	-	-	-	-	-	-	-	-	-	-
		-	2623-24B-24	-	-	-	-	-	-	-	-	-	-	-
		-	-	2632-24B-24	-	-	-	-	-	-	-	-	-	-
	32 PER UNIT	-	-	-	2170-32	-	-	-	-	-	-	-	-	-
		-	-	-	-	1269-16B-16	-	-	-	-	-	-	-	-
		-	-	-	-	-	2168-16B-16	-	-	-	-	-	-	-
		-	-	-	-	-	-	2165-32	-	-	-	-	-	-
		-	-	-	-	-	-	-	2164-16B-16	-	-	-	-	-
		-	-	-	-	-	-	-	-	2163-16B-16	-	-	-	-
	24 PER UNIT	-	-	-	-	-	-	-	-	-	2162-24	-	-	
-		-	-	-	-	-	-	-	-	-	2161-12B-12	-		
-		-	-	-	-	-	-	-	-	-	-	2160-12B-12		
INSERTS EACH	2633	2623	2632	2170	2169	2168	2165	-	2163	2162	2161	2160		
INSERTS EACH BEVELED	-	2623-B	2632-B	-	2169-B	1268-B	-	2164-B	2163-B	-	2161-B	2160-B		

7-11. 200/250 TON ELEVATOR/SPIDER ACCESSORIES

Table 7-11. 200/250 Ton Elevator/Spider Accessories

BVM Corp			QTY/ UNIT
ITEM #	PART #	1.2.3. DESCRIPTION	
1	79588	LEVER HANDLE.....	1
2	79772	BELL GUIDE.....	1
3	79105	FOOT PEDAL.....	1
4	79462	ADAPTER PLATE.....	1

7-12. 200/250 TON ELEVATOR/SPIDER FOREIGN SPARE PARTS

Table 7-12. 200/250 Ton Elevator/Spider Foreign Spare Parts

BVM Corp			QTY/ UNIT
ITEM #	PART #	1.2.3. DESCRIPTION	
	79147	One Years Foreign Spare Parts Kit (less inserts) for 200/250 Ton Elevator/Spider Unit.*.....	1
1	79751	RING, Wiper.....	4
2	79805	SCREW, Cap Modified.....	2
3	79261	SCREW, Cap Modified.....	2
4	79534	PIN, Spring.....	4
5	79588	HANDLE, Lever.....	1
6	79614	LATCH, Dog.....	1
7	79680	LATCH ASSEMBLY.....	1
8	79681	FOLLOWER, CAM.....	1
9	79141	LATCH RETAINER KIT.....	1
10	79146	HANDLE SLIP LIFTING KIT.....	4
11	1406C-12-5	CAPSCREW, Hex Head, 3/8 – 16 UNC X 1/2.....	4
12	1408C-12-5	CAPSCREW, Hex Head, 1/2 – 13 UNC X 2-1/4.....	12
13	1408C-12-5	CAPSCREW, Hex Head, 1/2 – 13 UNC X 1-1/2.....	4
14	1410C-10-5	CAPSCREW, Hex Head, 5/8 – 11 UNC X 1-1/4.....	3
15	1416C-14-5	CAPSCREW, Hex Head, 1 – 8 UNC X 2-1/4.....	4
16	6416C-00-0	NUT, Hex-Slotted, 1” UNC.....	2
17	2208C-10-5	CAPSCREW, Flat Head, 1/2 – 13 UNC X 1 1/4.....	2
18	20080-00-0	LOCKWASHER, 1/2”.....	16
19	20100-00-0	LOCKWASHER, 5/8”.....	3
20	20160-00-0	LOCKWASHER, 1”.....	4
21	30030-24-0	COTTER PIN, 3/16 X 2.....	2
22	30030-16-0	COTTER PIN, 3/16 X 2.....	2
23	79201	FITTING, Grease.....	17
24	601000-0	NUT, Hex Standard, 5/8” UNF.....	1

* Recommended Spares include one set of inserts for each size of casing used per unit



200/250 Ton Spider Elevator Pneumatic



SECTION VIII

PNEUMATIC OPERATIONS

8-1. OPERATION

The elevator and spider operations are controlled by a hand valve. This valve operates the latch handle and lift lever.

8-2. RAISING SLIPS

By moving the valve handle to the up position the slips will raise; once they completely disengage from the pipe, locate the handle back to the neutral position. This will allow the latch dog to engage and release all air from the lines.

8-3. SETTING SLIPS

By moving the valve handle to the down position the latch dog will disengage and allow the slips to lower and latch around the pipe. Once the slips have set, place the valve handle in the neutral position.

Note

Should the air supply be lost, the tool can be operated manually by placing the hand valve in the neutral position. Insert the lever bar into the lever socket and operate as a manual elevator/spider. The latch handle will work manually with out disconnecting the cylinders attached to the handle.

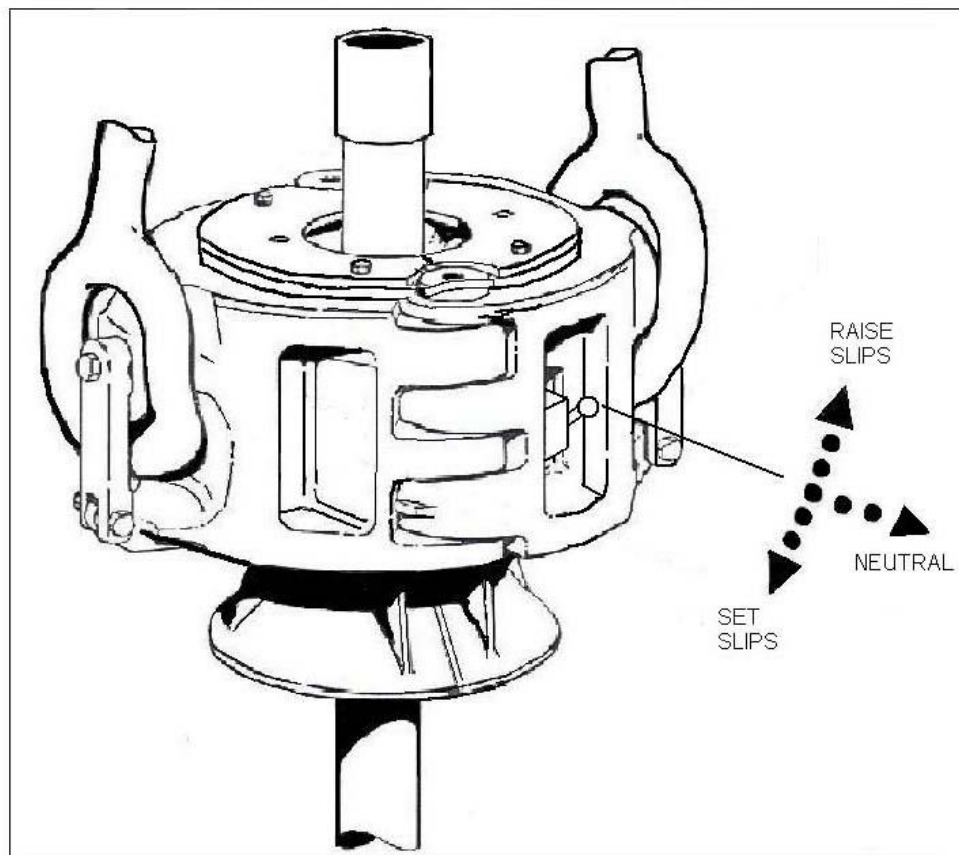

Figure 8-1. 200/250 Ton Air Operating Details

8-4. AIR OPERATING PARTS LIST

The parts lists in this section reflect part numbers and quantities used in the 200/250 Ton Air Operating Elevator/Spider. The quantity per unit column is the total number

of parts for the 200/250 Ton Air Operating Elevator/Spider.

The parts list uses the indentation method to show component subassembly relationships. Items listed one column to the right under assembly is detailed parts of that assembly.

8-5. 200/250 TON AIR OPERATING SPIDER ASSEMBLY

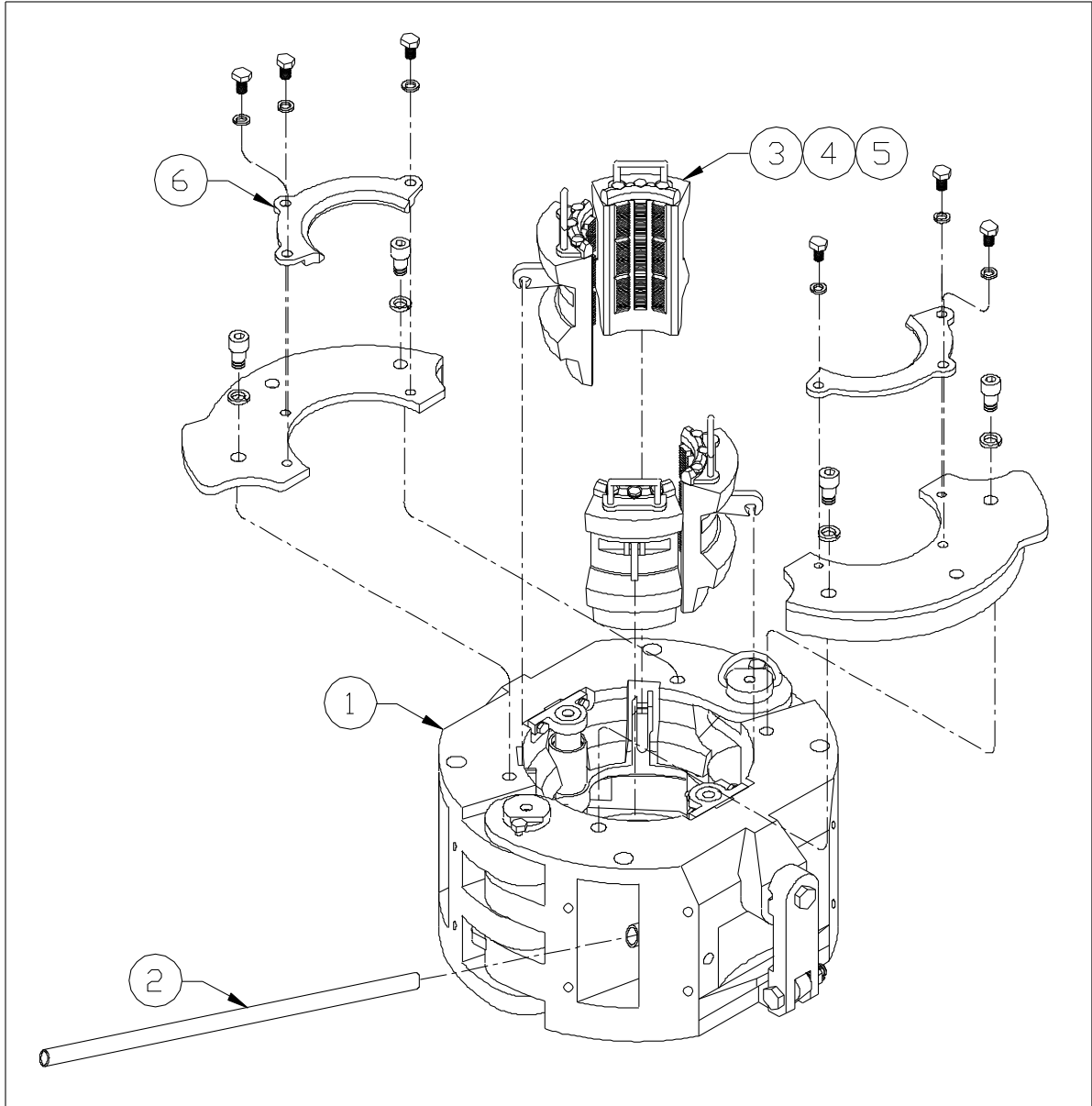

Figure 8-2. 200/250 Ton Air Operating Spider Assembly

Table 8-2. 200/250 Ton Air Operating Spider Parts List Index

200 TON AIR OPERATING SPIDER ASSEMBLY																
ITEM NO.	IN-DENT	PART NAME	7-5/8"			5-1/2"			4-1/2"			3-1/2"			QTY	REMARKS
			7 5/8"	7"	6-5/8"	5-1/2"	5"	4-1/2"	4-1/2"	4"	3-1/2"	3-1/2"	2-7/8"	2-3/8"		
-	0	200/250 TON AIR OPERATING SPIDER ASSY	79200P -1	79200P -3	79200P -5	79200P -7	79200P -9	79200P -11	79200P -13	79200P -15	79200P -17	79200P -19	79200P -21	79200P -23	REF	
1	1	ELEVATOR/SPIDER (undressed)	79200P	79200P	79200P	79200P	79200P	79200P	79200P	79200P	79200P	79200P	79200P	79200P	1	Fig. 8-4 for breakdown
2	1	LEVER HANDLE	79588	79588	79588	79588	79588	79588	79588	79588	79588	79588	79588	79588	1	
3	1	SLIP ASSY	79516-76	79516-70	79516-66	79519-55	79519-50	79519-45	79902-45	79902-40	79902-35	-	-	-	4	Fig. 7-8 for breakdown
4	1	SLIP ASSY, SINGLE	-	-	-	-	-	-	-	-	-	79522-35	79522-28	79522-23	2	Fig. 7-9 for breakdown
5	1	SLIP ASSY, DOUBLE	-	-	-	-	-	-	-	-	-	79526-35	79526-28	79526-23	2	Fig. 7-9 for breakdown
6	1	SPIDER GUIDE SET	79858	79859	79859	79860	79860	79861	79860	79862	79863	79863	79864	79528	1	Refer to Fig. 8-3 for attaching pairs

8-6. 200/250 TON AIR OPERATING ELEVATOR ASSEMBLY

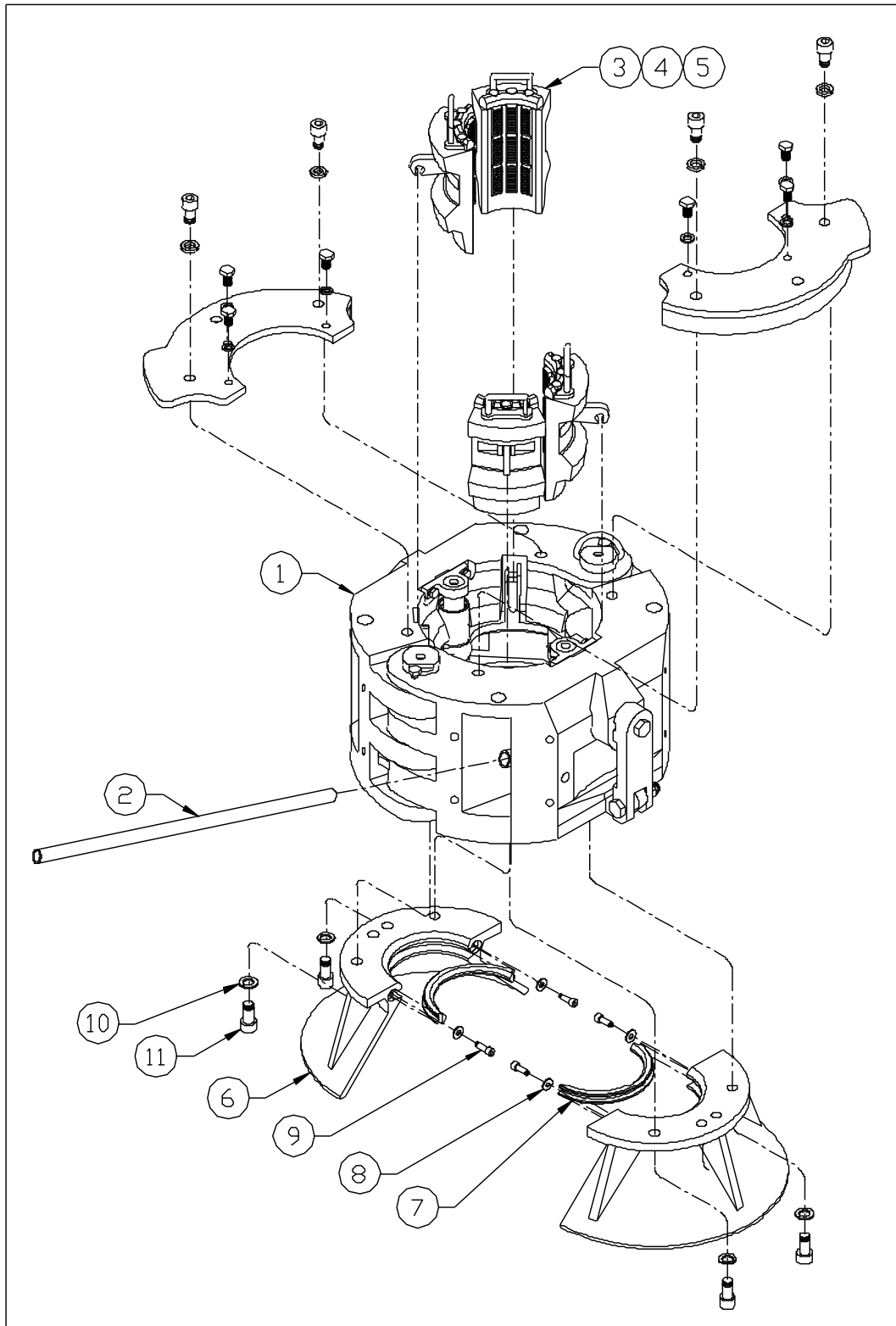

Figure 8-3. 200/250 Ton Air Operating Elevator Assembly

Table 8-3. 200/250 Ton Air Operating Elevator Parts List Index

200 TON AIR OPERATING ELEVATOR ASSEMBLY																
ITEM NO.	IN-DENT	PART NAME	7-5/8"			5-1/2"			4-1/2"			3-1/2"			QTY	REMARKS
			7 5/8"	7"	6-5/8"	5-1/2"	5"	4-1/2"	4-1/2"	4"	3-1/2"	3-1/2"	2-7/8"	2-3/8"		
-	0	200/250 TON AIR OPERATING SPIDER ASSY	79200P -2	79200P -4	79200P -6	79200P -8	79200P -10	79200P -12	79200P -14	79200P -16	79200P -18	79200P -20	79200P -22	79200P -24	REF	
1	1	ELEVATOR/SPIDER (undressed)	79200P	79200P	79200P	79200P	79200P	79200P	79200P	79200P	79200P	79200P	79200P	79200P	1	Fig. 8-4 for breakdown
2	1	LEVER HANDLE	79588	79588	79588	79588	79588	79588	79588	79588	79588	79588	79588	79588	1	
3	1	SLIP ASSY	79516-76	79516-70	79516-66	79519-55	79519-50	79519-45	79902-45	79902-40	79902-35	-	-	-	4	Fig. 7-8 for breakdown
4	1	SLIP ASSY, SINGLE	-	-	-	-	-	-	-	-	-	79522-35	79522-28	79522-23	2	Fig. 7-9 for breakdown
5	1	SLIP ASSY, DOUBLE	-	-	-	-	-	-	-	-	-	79526-35	79526-28	79526-23	2	Fig. 7-9 for breakdown
6	1	BELL GUIDE, HALF	79111	79111	79111	79111	79111	79111	79111	79111	79111	79111	79111	79111	1	For repl. Order 79772
7	1	ELEVATOR GUIDE, SET	79865	79866	79866	79867	79867	79868	79868	79869	79870	79870	79871	79751	1	
8	1	WASHER, FENDER	24080-00-0	24080-00-0	24080-00-0	24080-00-0	24080-00-0	24080-00-0	24080-00-0	24080-00-0	24080-00-0	24080-00-0	24080-00-0	24080-00-0	4	
9	1	SCREW, BUTTON HEAD CAP	1608C-06-5	1608C-06-5	1608C-06-5	1608C-06-5	1608C-06-5	1608C-06-5	1608C-06-5	1608C-06-5	1608C-06-5	1608C-06-5	1608C-06-5	1608C-06-5	4	
10	1	LOCKWASHER	20160-00-0	20160-00-0	20160-00-0	20160-00-0	20160-00-0	20160-00-0	20160-00-0	20160-00-0	20160-00-0	20160-00-0	20160-00-0	20160-00-0	4	
11	1	SCREW, CAP HEX HEAD	1416C-16-5	1416C-16-5	1416C-16-5	1416C-16-5	1416C-16-5	1416C-16-5	1416C-16-5	1416C-16-5	1416C-16-5	1416C-16-5	1416C-16-5	1416C-16-5	4	

8-7. 200/250 TON AIR OPERATING ELEVATOR/SPIDER ASSEMBLY

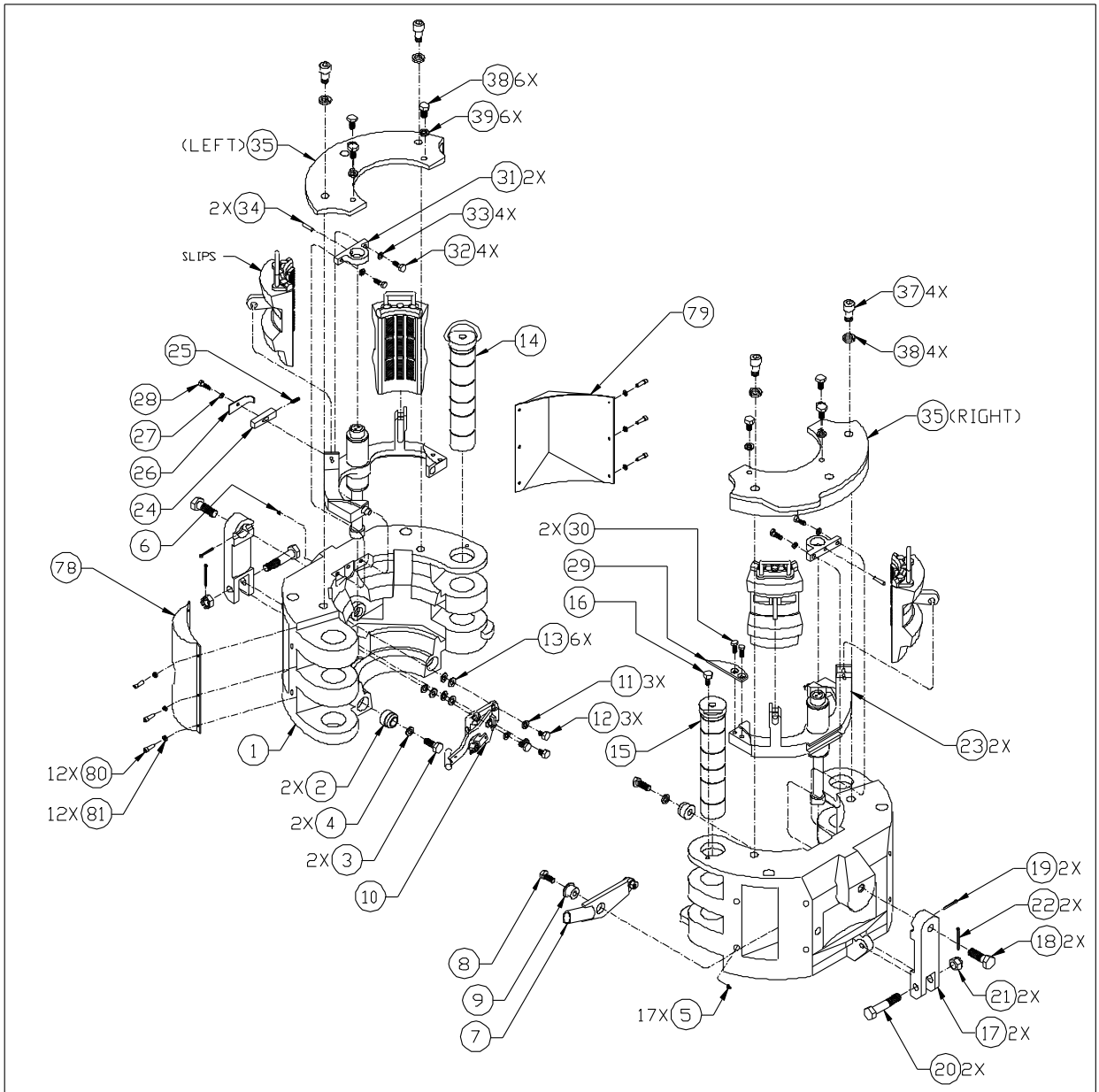

Figure 8-4. 200/250 Ton Air Operating Elevator/Spider Assembly (Part 1 of 3)

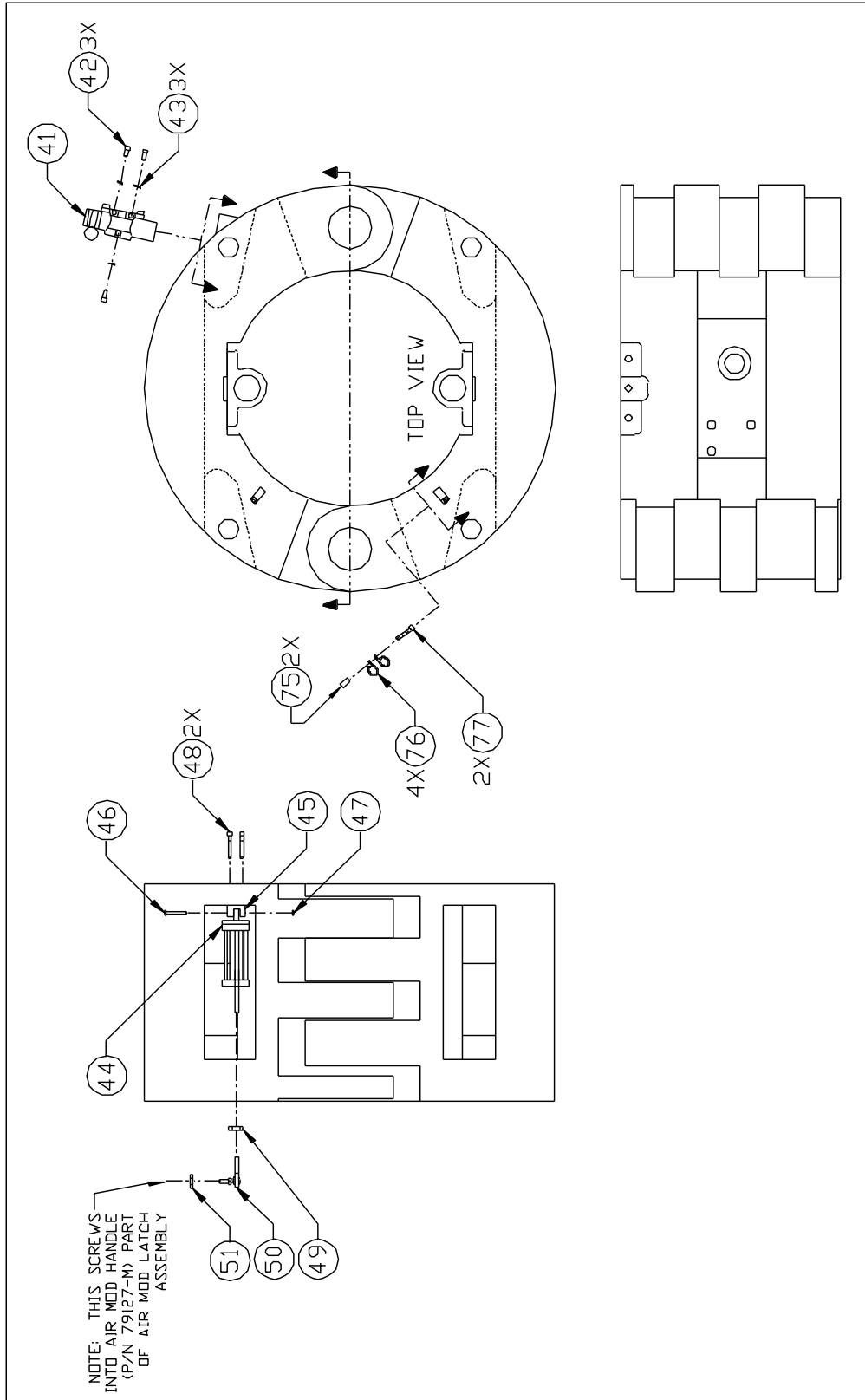

Figure 8-4. 200/250 Ton Air Operating Elevator/Spider Assembly (Part 2 of 3)

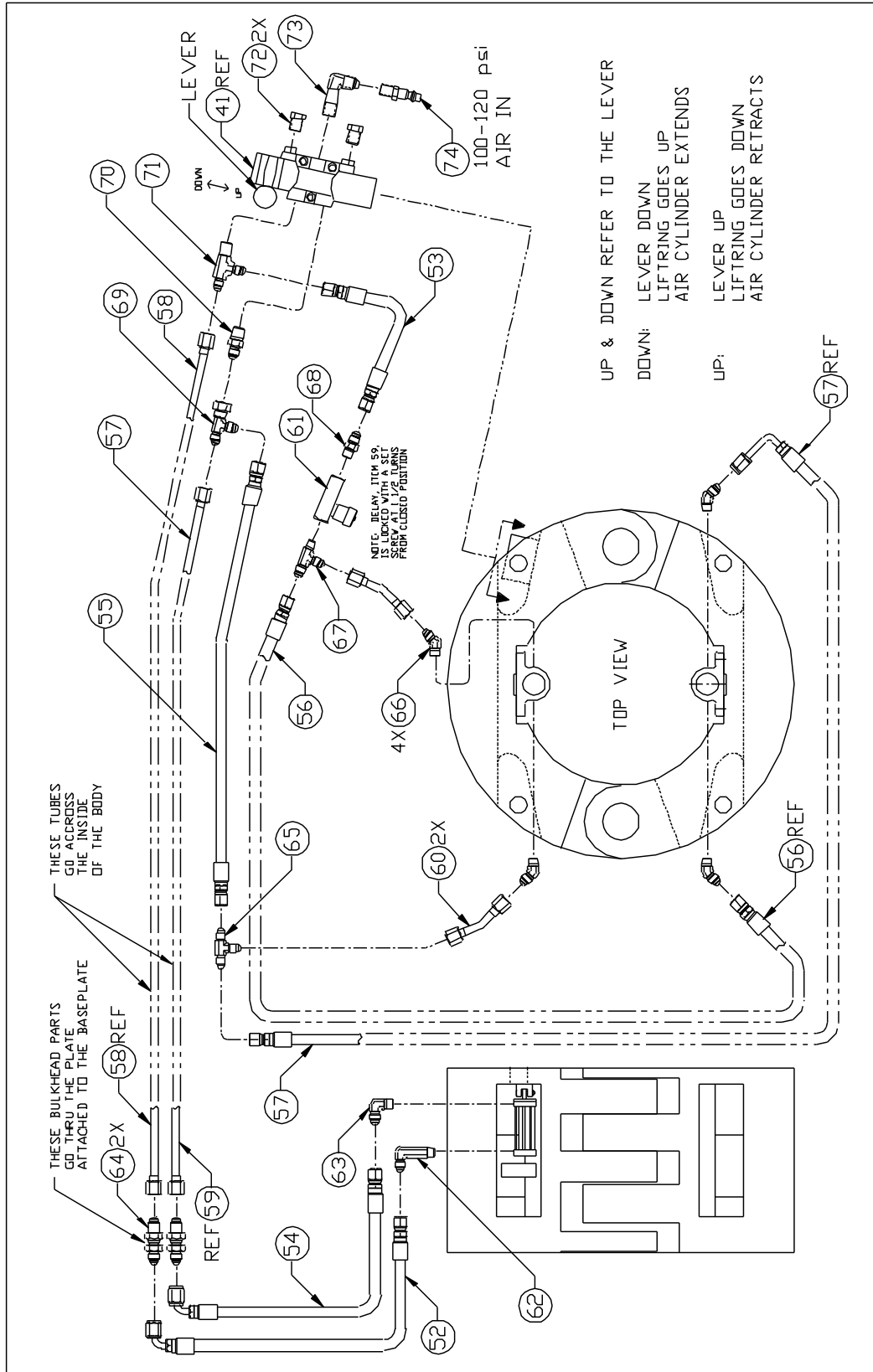

Figure 8-4. 200/250 Ton Air Operating Elevator/Spider Assembly (Part 3 of 3)

Table 8-4. 200/250 Ton Air Operating Elevator/Spider Parts List Index

ITEM #	BVM Corp PART #	1.2.3. DESCRIPTION	QTY/ UNIT
	79200P	ELEVATOR/SPIDER ASSY, 200/250 Ton Air Operating.	Ref.
1	79109M	BODY.....	1
2	79882	BUTTON, Register.....	2
3	1212C-16-8	SCREW, Socket Head.....	2
5	940308-1	FITTING, Grease.....	17
6	79001-12-C	PLUG, Pipe.....	1
7	79090	LEVER ASSY, Beam Lifting (see Fig. 7-5 for breakdown).....	1
8	1410C-14-5	SCREW, Cap Hex Head.....	1
9	79585	PIVOT, Lever.....	1
10	79680M	LATCH ASSY, Air Operating (see Fig. 8-5 for breakdown).....	1
11	20100-00-0	LOCKWASHER.....	3
12	1410C-14-5	SCREW, Cap Hex Head.....	3
13	22100-00-0	WASHER, Flat.....	6
14	79120	PIN ASSY, Removable Hinge.....	1
15	79120	PIN ASSY, Stationary Hinge.....	1
16	79610	SCREW, Shoulder Hex Head.....	1
17	79803	CATCH LINK.....	2
18	79805	SCREW, Upper Link Block.....	2
19	30030-32-0	PIN, Cotter.....	2
20	79261	SCREW, Lower Link Block.....	2
21	6816C-00-5	NUT, Castle.....	2
22	30030-24-0	PIN, Cotter.....	2
23	79116M	BEAM ASSY, Air Operating Leveling (see Fig. 8-6 for breakdown).....	2
24	79614M	LATCH, Dog Modified.....	1
25	79616	SPRING, Compression (for replacement order 79141)....	1
26	79615	RETAINER, Dog (for replacement order 79141).....	1
27	20060-00-0	LOCKWASHER.....	1
28	1406C-12-5	SCREW, Cap Hex Head.....	1
29	79609	TANG, Leveling Beam Support (for replacement order 79518).....	1
30	1008C-08-0	SCREW, Flat Head.....	2
31	79126	BLOCK, Pillow (for replacement order 79520).....	2
32	1208C-12-8	SCREW, Socket Head.....	4
33	20080-00-0	LOCKWASHER.....	4
34	79606-3	PIN, Pillow Block.....	2
35	10422	RETAINER ASSEMBLY, Air Operated Top.....	1
36	----	NOT USED	
37	1416C-32-5	SCREW, Cap Hex Head.....	4
38	20160-00-0	LOCKWASHER.....	4
39	1412F-10-5	SCREW, Cap Hex Head.....	6
40	20120-00-0	LOCKWASHER.....	6

41	79930	VALVE, Beam Air Actuator.....	1
42	1204F-12-5	SCREW, Socket Head Cap.....	3
43	20040-00-0	LOCKWASHER.....	3
44	79933	CYLINDER, Latch.....	1
45	10442	BRACKET, Air Cylinder.....	1
46	120JF-14-8	SCREW.....	1
47	620JF-00-0	LOCKNUT.....	1
48	1204C-24-8	SCREW, Socket Head Cap	2
49	6005F-00-0	NUT, Hex.....	1
50	79937	LINKAGE ROD ENDS.....	1
51	6205F-00-0	LOCKNUT.....	1
52	10435	HOSE, Retract.....	1
53	10436	HOSE, Main Beam Lower.....	1
54	10437	HOSE, Extend.....	1
55	10438	HOSE, Main Beam Lift.....	1
56	10439	HOSE, Farside Beam Lower.....	1
57	10440	HOSE, Farside Beam Lift.....	1
58	10444	TUBE, Air Cylinder Retract.....	1
59	10445	TUBE, Air Cylinder Extend.....	1
60	10446	TUBE, Lift Cylinder Extension.....	1
61	BPF200B	DELAY.....	1
62	B4-CCCTX-S	ELBOW, Extra Long Male.....	1
63	B4-CTX-S	ELBOW, Male.....	1
64	B4-WTX-S	UNION, Bulkhead.....	2
65	B4-JTX-S	TEE, Union.....	1
66	B4-VTX-S	ELBOW, 45 Deg Male.....	4
67	B4-RTX-S	TEE, Male Run.....	1
68	B4-FTX-S	CONNECTOR, Male.....	1
69	B4-R6X-S	TEE, Swivel Nut Run.....	1
70	B4-4-FTX-S	CONNECTOR, Male.....	1
71	B4-4-4-RTX-S	TEE, Male Run.....	1
72	BBV2	VENT, 1/4" Breather.....	2
73	B1/4 CR-S	ELBOW, Male Pipe.....	1
74	BH3C	FPT 2/30 Series.....	1
75	10447	RAISER, Clamp.....	1
76	10448	CLAMP.....	4
77	1204C-10-8	SCREW, Socket Head Cap.....	2
78	10431	METAL GUARD, Rounded.....	1
79	10432	METAL GUARD, Triangle.....	1
80	1206C-06-8	SCREW, Socket Head Cap.....	12
81	20060-00-0	LOCKWASHER.....	12

8-8. AIR OPERATING LATCH ASSEMBLY

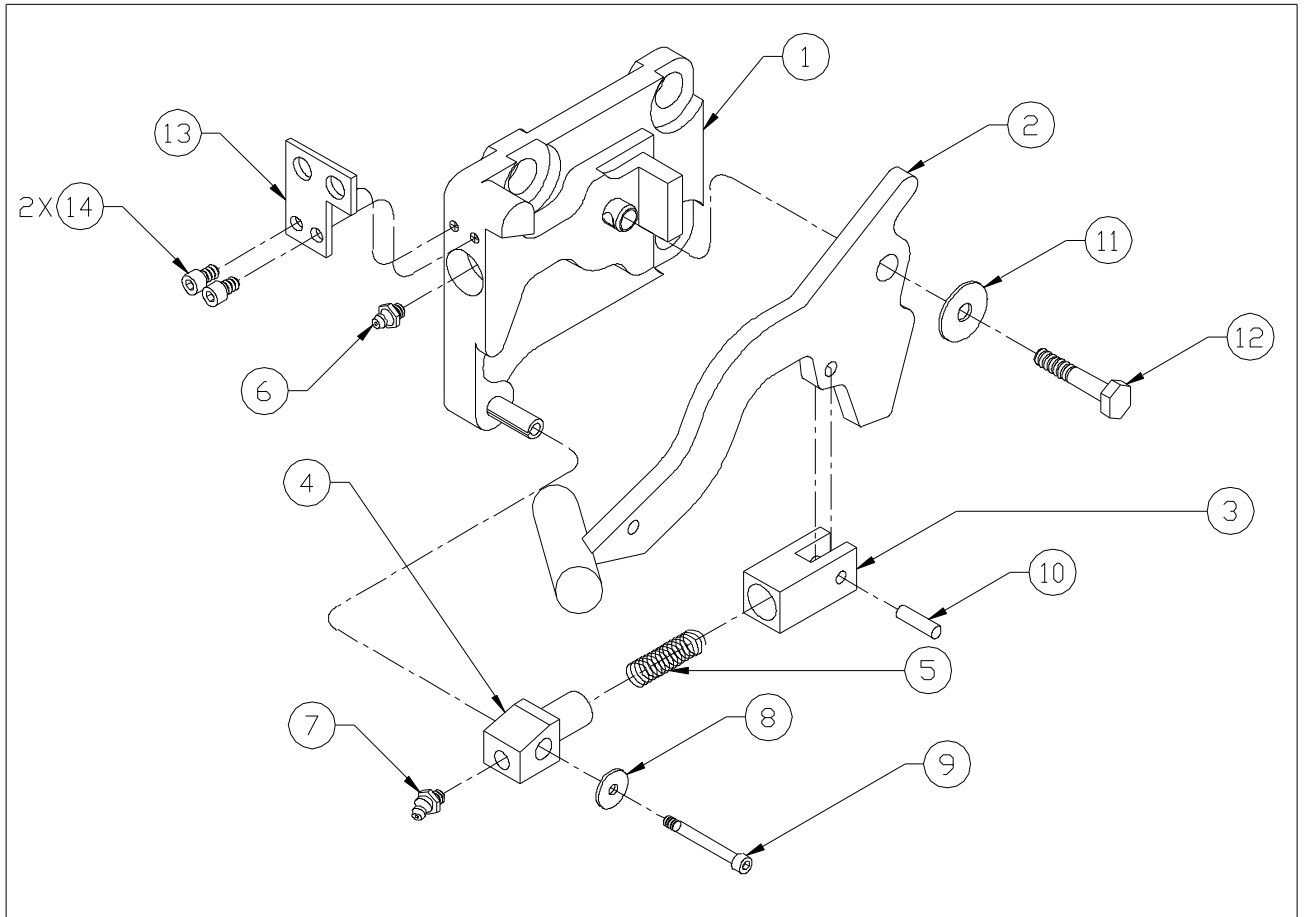

Figure 8-5. Air Operating Latch Assembly

Table 8-5. Air Operating Latch Parts List Index

BVM Corp			QTY/
ITEM #	PART #	1.2.3. DESCRIPTION	UNIT
	79680M	LATCH ASSY, Air Operating (see Fig. 8-4 for NHA).....	Ref.
1	79679	BASE ASSY, Latch.....	1
2	79127M	HANDLE, Air Operating Latch.....	1
3	79684	CLEVIS, Toggle.....	1
4	79683M	SPRING BLOCK, Air Operating.....	1
5	79682	SPRING, Compression.....	1
6	940308-1	FITTING, Grease.....	1
7	79202	FITTING, Grease.....	1
8	220J0-00-0	WASHER, Flat.....	1
9	120JF-14-5	SCREW, Hex Head.....	1
10	40040-06-0	PIN, Roll.....	1
11	22050-00-0	WASHER, Flat.....	1
12	1405C-14-5	SCREW, Cap Hex Head.....	1
13	10411	PLATE, Bulkhead.....	1
14	1204C-03-5	SCREW, Socket Head Cap.....	2
15	79937	MALE LINKAGE.....NOT SHOWN.....	1
16	10442	AIR CYLINDER BRACKET.....NOT SHOWN.....	1

8-9. AIR OPERATING LEVELING BEAM ASSEMBLY

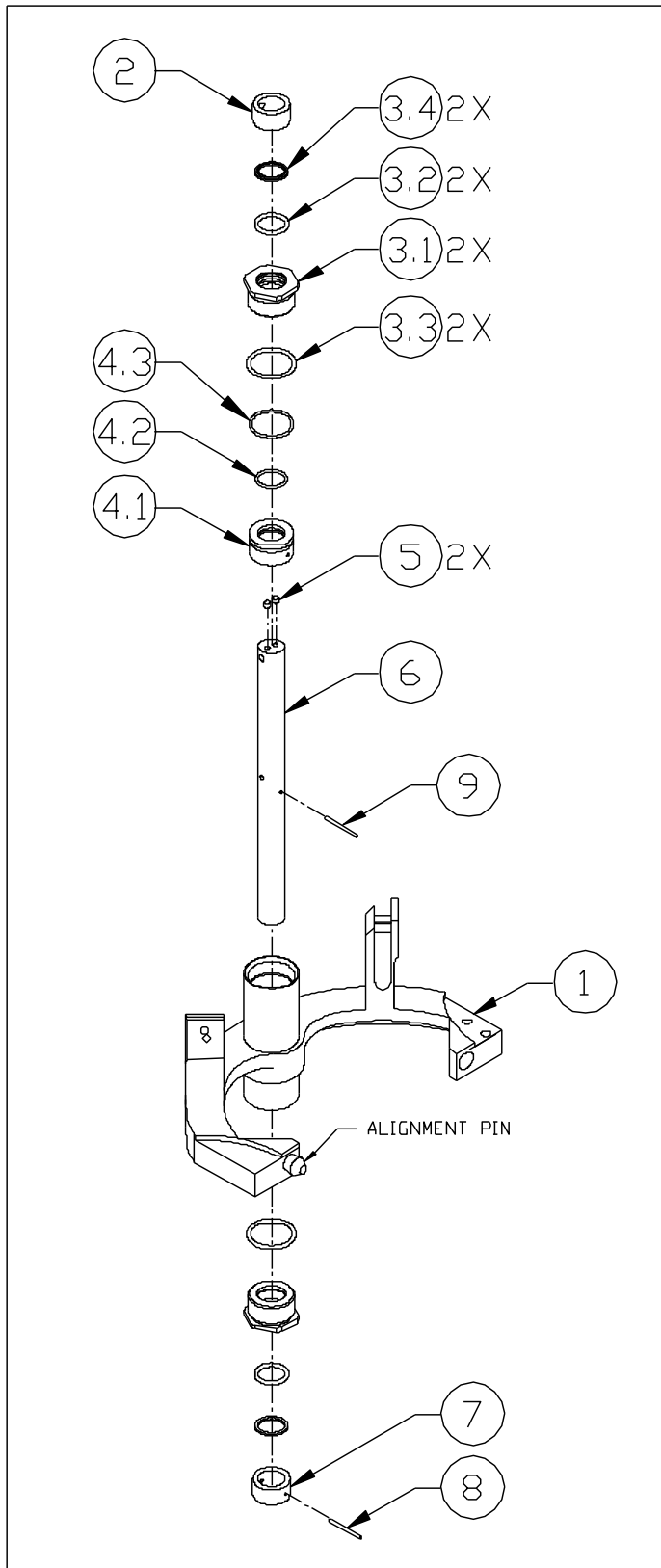

Figure 8-6. Air Operating Leveling Beam Assembly

Table 8-6. Air Operating Leveling Beam Parts List Index

BVM Corp			QTY/ UNIT
ITEM #	PART #	1.2.3. DESCRIPTION	
	79116M	BEAM ASSEMBLY, Air Operating Leveling (see Fig. 8-4 for NHA).....	Ref.
1	79722M	BEAM ASSEMBLY, Air Operating	1
-	79722-1	ALIGNMENT PIN.....	-
2	10423	BUSHING TOP.....	1
3	10416	GLAND ASSEMBLY.....	2
3.1	10413	GLAND.....	-
3.2	B51300-325-B	SEAL, O-Ring.....	-
3.3	B51300-329-B	SEAL, O-Ring.....	-
3.4	B940-15	RING, Wiper.....	-
4	10417	PISTON ASSEMBLY.....	1
4.1	10414	PISTON.....	-
4.2	B51300-220-B	SEAL, O-Ring.....	-
4.3	B51300-227-B	SEAL, O-Ring.....	-
5	79001-12-C	PLUG, Pipe.....	2
6	10415	SHAFT.....	1
7	10424	BUSHING BOTTOM.....	1
8	40030-16-0	PIN, Roll.....	1
9	40030-18-0	PIN, Roll.....	1

8-10. AIR OPERATING MULTI-INSERT SLIP ASSEMBLY

See Table 7-8.

8-11. AIR OPERATING DOUBLE/SINGLE SLIP ASSEMBLY

See Table 7-9.

8-12. 200/250 TON AIR OPERATING ELEVATOR/SPIDER SLIP ASSEMBLIES, GUIDES AND INSERTS

See Table 7-10.

8-13. 200/250 TON AIR OPERATING ELEVATOR/SPIDER ACCESSORIES

See Table 7-11.

8-14. 200/250 TON AIR OPERATING ELEVATOR/SPIDER FOREIGN SPARE PARTS

ITEM #	BVM Corp PART #	1.2.3. DESCRIPTION	QTY/ UNIT
	79147	One Years Foreign Spare Parts Kit (less inserts) for 200/250 Ton Elevator/Spider Unit.*.....	1
1	10433	LIFT BEAM SEAL KIT.....	1
2	79805	SCREW, Upper Link Block.....	2
3	79261	SCREW, Lower Link Block.....	2
4	79534	PIN, Spring.....	4
5	79588	HANDLE, Lever.....	1
6	79614-M	LATCH, Dog Modified.....	1
7	79680M	LATCH ASSEMBLY, Air Operating.....	1
8	79681	FOLLOWER, CAM.....	1
9	79141	LATCH RETAINER KIT.....	1
10	79146	HANDLE SLIP LIFTING KIT.....	4
11	1406C-12-5	CAPSCREW, Hex Head, 3/8 – 16 UNC X 1/2.....	4
12	1408C-12-5	CAPSCREW, Hex Head, 1/2 – 13 UNC X 2-1/4.....	12
13	1408C-12-5	CAPSCREW, Hex Head, 1/2 – 13 UNC X 1-1/2.....	4
14	1410C-10-5	CAPSCREW, Hex Head, 5/8 – 11 UNC X 1-1/4.....	3
15	1416C-32-5	CAPSCREW, Hex Head, 1 – 8 UNC X 4.....	4
16	6416C-00-0	NUT, Hex-Slotted, 1” UNC.....	2
17	2208C-10-5	CAPSCREW, Flat Head, 1/2 – 13 UNC X 1 1/4.....	2
18	20080-00-0	LOCKWASHER, 1/2”.....	16
19	20100-00-0	LOCKWASHER, 5/8”.....	3
20	20160-00-0	LOCKWASHER, 1”.....	4
21	30030-24-0	COTTER PIN, 3/16 X 2.....	2
22	30030-16-0	COTTER PIN, 3/16 X 1.....	2
23	79201	FITTING, Grease.....	17
24	601000-0	NUT, Hex Standard, 5/8” UNF.....	1

* Recommended Spares include one set of inserts for each size of casing used per unit