

# Operating Instructions & Parts Manual

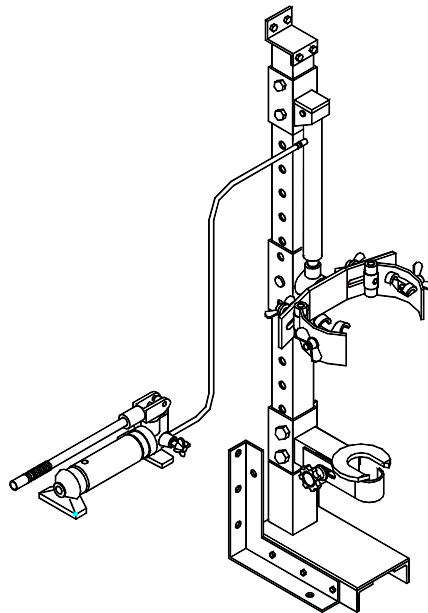

## Hydraulic Strut Spring Compressor

Model Number: 90000



This is the safety alert symbol. It is used to alert you to potential personal injury hazards. Obey all safety messages that follow this symbol to avoid possible injury or death.

### ADVERTENCIA

- Leer, comprender, y seguir las instrucciones antes de utilizar el aparato.
- El manual de instrucciones y la información de seguridad deben estar comunicado en lengua del operador antes del uso.
- No seguir estas indicaciones puede causar daños personales o materiales.

**SFA Companies**

<http://www.omegalift.com>

**Read this manual and follow all the Safety Rules and Operating Instructions before using this product.**

Printed in China  
90000-MR rev 12/07

## SAFETY and GENERAL INFORMATION

**Save these instructions.** For your safety, read and understand the information contained within. The owner and operator shall have an understanding of this product and safe operating procedures before attempting to use this product. Instructions and Safety information shall be conveyed in the operator's native language before use of this product is authorized. Make certain that the operator thoroughly understands the inherent dangers associated with the use and misuse of the product. If any doubt exists as to the safe and proper use of this product as outlined in this factory authorized manual, remove from service.

**Inspect before each use.** Do not use if broken, bent, cracked or otherwise damaged parts are noted. Owners and operators of this equipment shall be aware that the use and subsequent repair of this equipment may require special training and knowledge. If this product appears to be damaged in any way, is worn or operates abnormally it shall be removed from service immediately and the manufacturer notified. It is recommended that an annual inspection be done by qualified personnel. Contact the manufacturer or distributor for a list of Authorized Service Centers. Labels and Operator's Manuals are available from manufacturer.

## PRODUCT DESCRIPTION

This Hydraulic Strut Spring Compressor is designed as an aid in replacing strut springs and strut assembly components. The adjustable strut shaft clasp secures the strut during operation. The spring clasp claws can be rotated to fit *many, but not all* struts. **Intended use:** To compress springs for strut repair.

**⚠ Do not use for any purpose other than those uses outlined above!**

## SPECIFICATIONS

Model	Size (L x W x H)	Hydraulic Stroke	Recommended Strut Spring Dia.	Max. Working Space	Operating Force
90000	12 1/4" x 11 7/8" x 52 5/8"	10"	5" ~ 9"	15 1/2"	102 lb.

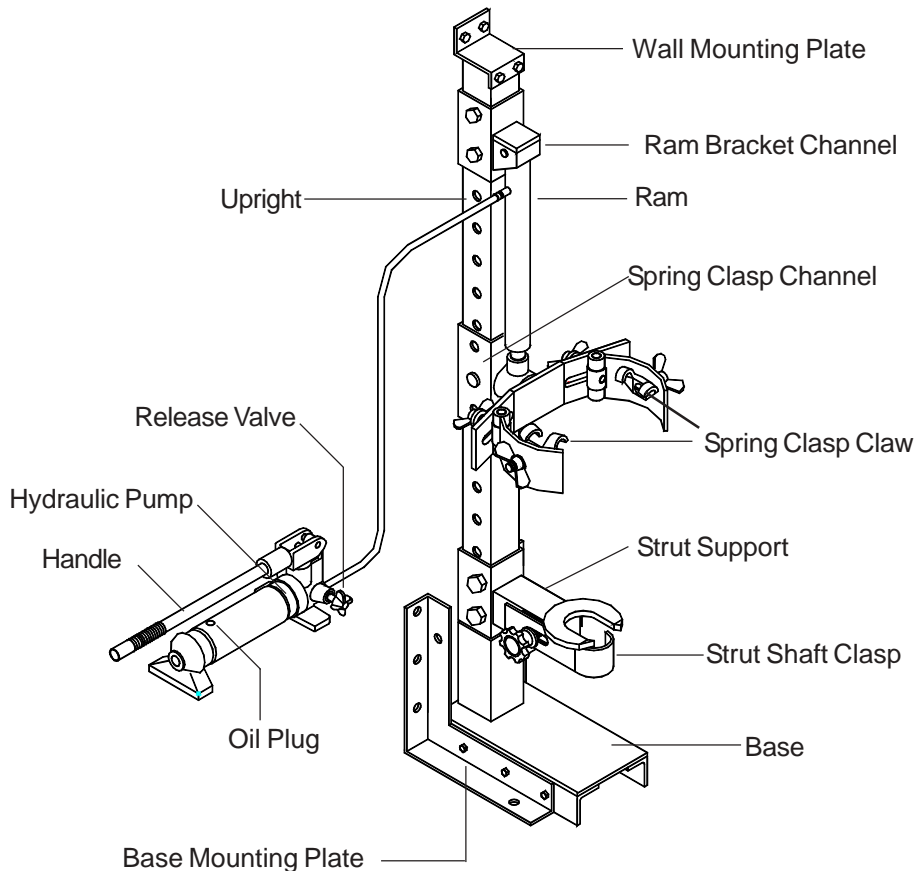

Figure 1 - Model 90000 Components

# ASSEMBLY

1. The product is preassembled except the upper and base mounting plates.

2 (a) For beam, bench & floor mount:

Attach Lower Wall Brackets (#14 & #16) to Upright (#13) using 4 Bolts (#15), 8 Washers (#20) and 4 Nuts (#26).

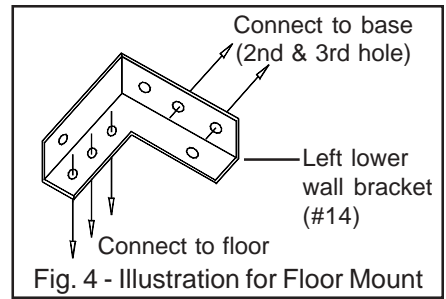
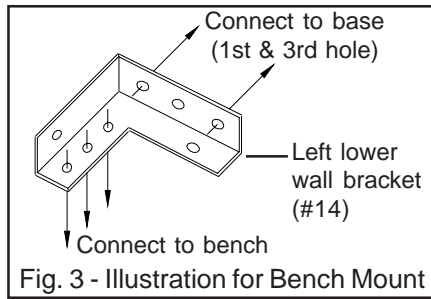
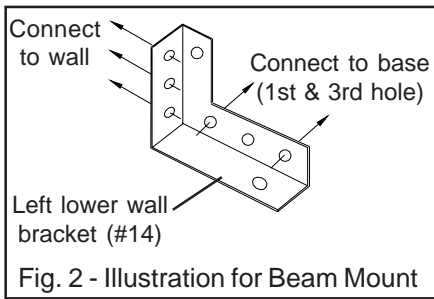

2 (b) For roll around legs option:

Attach each Leg (#35) to Upright (#13) using 4 Bolts (#38), 4 Nuts (#39) and 8 Washers (#40).

**Note:** Do not attach lower wall brackets with roll around leg option.

**Note:** Wall mount is not for use on wooden studs, sheet rock or similar materials.

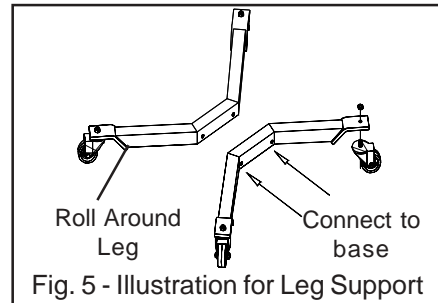

3. Attach Upper Wall Bracket (#11) to top of Upright using 2 Bolts (#12). (optional for Bench and Floor mounting, and not needed for leg support option). **Note:** Hardware needed to secure product to wall/ beam is not included.

4. Adjust strut support (#7) to fit the spring strut.

**Note:** Apply a light coating of bearing grease to mid-section of upright before using.

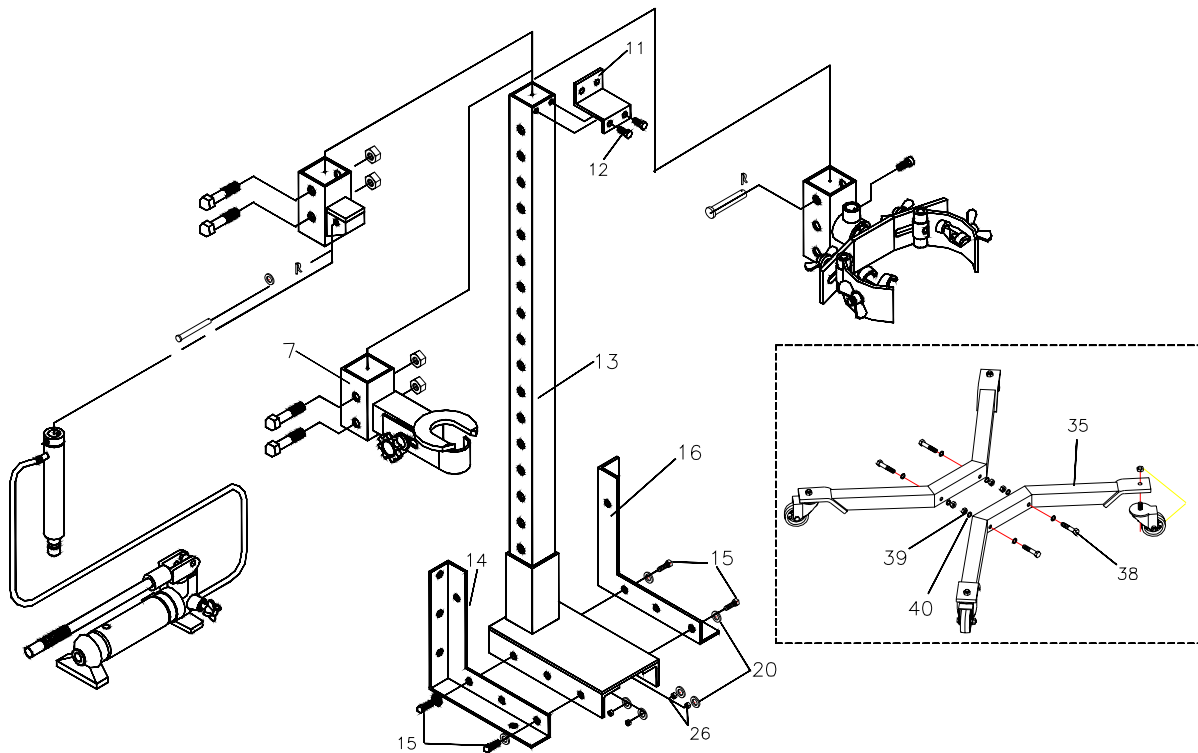

## BEFORE USE

**Note:** Never service strut spring compressor while in use.

1. Verify that the product and the application are compatible, if in doubt call Omega Technical Service (888) 332-6419.
2. Before using this product, read the operator's manual completely and familiarize yourself thoroughly with the product, its components and recognize the potential hazards associated with its use.
2. Always refer to and have available a credible service manual covering the year, make and model of the vehicle being serviced. Follow manufacturer's guidelines for strut removal, service and installation procedures.
3. Inspect before each use. DO NOT USE if bent, broken, cracked or leaking parts are noted. Repair or replace with factory authorized components only.

 <b>WARNING</b>
<ul style="list-style-type: none"><li>• <b>Study, understand, and follow</b> all instructions provided with and on this device <b>before use</b>.</li><li>• Ensure workpiece is compatible with and is securely fastened in compressor fixture.</li><li>• Spring must be compressed sufficiently to remove retaining nut and hardware.</li><li>• Never leave loaded spring compressor unattended.</li><li>• Use only on hard, level surfaces</li><li>• Do not use this device for any purpose other than that for which it is intended.</li><li>• Do not modify this device.</li><li>• <b>Failure</b> to heed these markings may <b>result in personal injury and/or property damage</b>.</li></ul>

 <b>WARNING</b>	
	Crush Hazard. Keep hands and feet from loading area.

 <b>WARNING</b>	
	Reduce risk of eye injury by wearing safety goggles when working with or around this device.

## OPERATION

Refer to the vehicle service manual, and follow the manufacturer's recommended procedure to remove the strut assembly from the vehicle.

1. Secure the base of strut assembly to the compressor fixture by adjusting the strut shaft clasp (*refer to Fig. 9*).
2. Secure the spring with claws of spring clasp (*refer Fig. 10*).
3. Ensure that the strut assembly is set up vertically, and the spring is clasped centrally and evenly (*refer to Fig. 7*).



**DO NOT** use this strut spring compressor to compress springs which do not fully nest inside the claws of the spring clasp assemblies. If a spring coil is only partially captured within the claw of a clasp assembly, **STOP**, remove the strut spring assembly from the strut spring compressor. This means that the application is **not** compatible to this type of product.

4. Close the pump release valve and start pumping to compress the spring.
5. After spring is compressed, install safety bar into the hole on upright directly above strut spring channel (*refer figure 8*).
6. Ensure the spring is securely hooked on before removing the nut and retainer cup from the strut assembly.
7. Remove safety bar and decompress spring by opening the pump release valve slowly but no more than 2 full turns.
8. Remove/replace spring, components as needed.
9. Close the pump release valve and pump the handle to compress the new spring. Before compressing the spring, ensure that the spring is securely hooked on the spring clasp.
10. Install safety bar in upright directly above strut spring channel.
11. Install retainer cup assembly and nut.
12. Remove safety bar and decompress spring by opening the pump release valve.
13. Remove strut assembly from fixture.

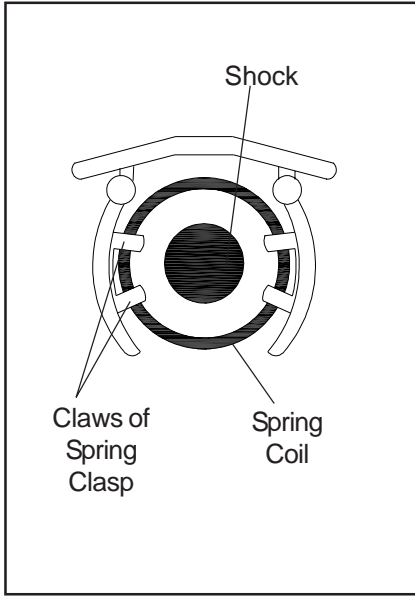

Figure 7

Ensure that the strut assembly is set up vertically, and the spring is clamped centrally and evenly.

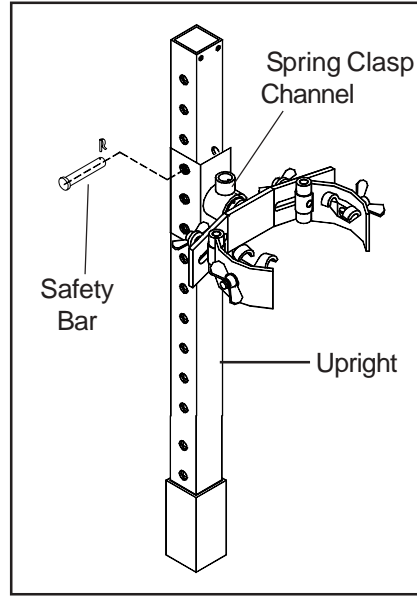

Figure 8

Install safety bar in upright directly above the strut spring channel.

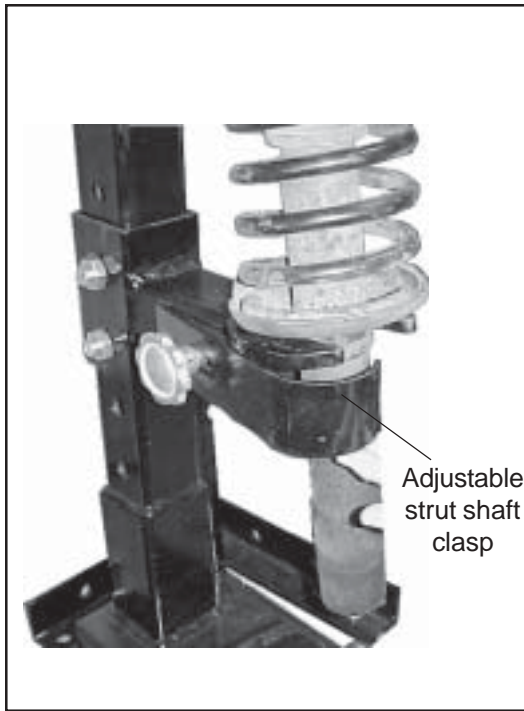

Figure 9

Secure the base with strut shaft clasp.

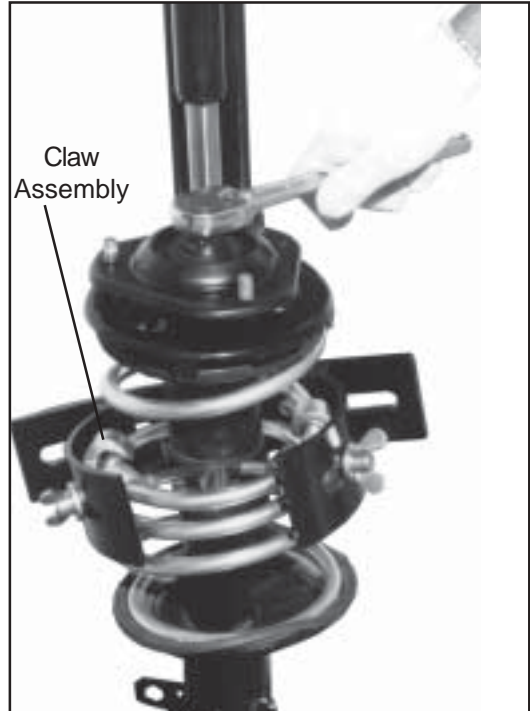

Figure 10

Position strut spring upright to service upper strut components.

## MAINTENANCE

1. Lubrication of upright is required in normal service. Coat all exposed surfaces with a light machine oil. **DO NOT** allow lubricant to contact claw assemblies nor strut springs. If so, clean and dry thoroughly before using in the spring compressor.

2. For ram and pump, always use clean approved hydraulic fluid and change as recommended or sooner if the fluid becomes contaminated. Keep hydraulic system as free of dirt as possible. Inspect hoses and connections daily. Tighten connections as needed. Use pipe thread sealing compound when servicing connections.

**Important:** Use only a good grade hydraulic jack oil. Avoid mixing different types of fluid and Never use brake fluid, turbine oil, transmission fluid, motor oil or glycerin. Improper fluid can cause premature failure of the ram and the potential for sudden and immediate loss of load. We recommend Mobil DTE 13M or equivalent.

### To Add/Change Hydraulic Fluid

Depressurize and disconnect hydraulic hose from application. Remove oil plug on top of the reservoir. Pour used fluid into a sealable container. With pump in its upright, horizontal position, use a small funnel to fill reservoir to within 1/4" (6mm) of the opening. Wipe up any spilled fluid and reinstall the oil plug.

**Note:** Dispose of hydraulic fluid in accordance with local regulations.

## TROUBLESHOOTING

Symptom	Possible Causes	Corrective Action
Ram will not extend, or respond to pressurized fluid	<ul style="list-style-type: none"> <li>• Release valve not closed</li> <li>• Contact Service Center</li> </ul>	<ul style="list-style-type: none"> <li>• Ensure release valve closed</li> <li>• Contact Service Center</li> </ul>
Ram responds to pressurized fluid, but system does not maintain pressure	<ul style="list-style-type: none"> <li>• Release valve not closed</li> <li>• Dirt in pump's return check valve</li> <li>• Hydraulic unit malfunction</li> </ul>	<ul style="list-style-type: none"> <li>• Ensure release valve closed</li> <li>• Contact Service Center</li> <li>• Contact Service Center</li> </ul>
Ram will not return fluid to pump	<ul style="list-style-type: none"> <li>• Malfunctioning coupler damaged application</li> <li>• Reservoir overfilled</li> <li>• Bent plunger/ ram damage</li> </ul>	<ul style="list-style-type: none"> <li>• Open release valve, <b>depressurize</b> pump and hose, remove application and replace coupler</li> <li>• Drain fluid to proper level</li> <li>• Replace ram</li> </ul>
Ram will not <b>fully</b> extend (cylinder or spreader)	<ul style="list-style-type: none"> <li>• Fluid level low</li> </ul>	<ul style="list-style-type: none"> <li>• Open release valve, <b>depressurize</b> pump and hose, remove application, then add fluid to proper level</li> </ul>
Poor performance	<ul style="list-style-type: none"> <li>• Fluid level low</li> <li>• Air trapped in system</li> </ul>	<ul style="list-style-type: none"> <li>• Ensure proper fluid level</li> <li>• Vent the system (refer to figure 11)</li> </ul>

### To bleed air from system (refer to Fig 11)

Place pump at a higher elevation than the hose and ram. The objective is to "float the air bubbles up hill and back to the reservoir where they belong. Close valve and extend ram as fast as possible. Open valve fully allowing oil and air to return to reservoir. Repeat this procedure two or three times will do the trick. To vent the pump, just open the oil plug to let air escape.

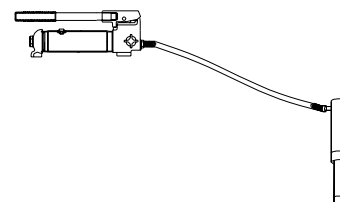

Figure 11 - Pump and ram illustration to bleed air

# REPLACEMENT PARTS

Not all components of the product are replacement items, but are illustrated as a convenient reference of location and position in the assembly sequence. When ordering parts, give Model number, serial number and description. Call or write for current pricing: SFA Companies 10939 N. Pomona Ave. Kansas City, MO 64153, U.S.A. Tel:(888)332-6419 Fax:(816)891-6599 E-Mail: sales@omegalift.com Omega Website: http://www.omegalift.com

Ref	Part#	Description	Qty
1	H22-1-2000-100	Ram piston	1
2	434-0-1000-104	Hydraulic pump	1
3	H22-3-8100-106	Ram bracket	1
4	513-5-0020-101	Spring clip	2
5	518-4-0160-106	Safety Bar D15.8 x 96	1
6	518-4-0100-209	Ram position pin D10 x 76	1
7	H22-3-8600-106	Strut support	1
8	649-1-0100-100	Bolt M10x1.5x10L	1
9	511-3-0104-109	Washer D20x10.4x1.2	1
10	H22-6-8605-104	Strut shaft clasp	1
11	H22-6-8608-100	Wall bracket - upper	1
12	653-1-0100-014	Bolt M10x1.5x16L	2
13	H22-3-8500-102	Upright assy.	1
14	H22-3-8607-100	Wall bracket - lower left	1
15	653-1-0127-500	Bolt 1/2"-12UNC x1 1/4"	4
16	H22-3-8606-108	Wall bracket - lower right	1
17	649-1-0080-027	Bolt - M8x1.25Px15L	1
18	H22-3-8200-100	Spring clasp channel	1
19	681-1-0127-010	Wing nut 1/2" - 12 UNC	4
20	511-3-0130-010	Washer D24 x 13 x 2.5T	8
21	514-2-0018-103	Spring D18 x 2 x 15	2

Ref	Part#	Description	Qty
22	H22-3-8204-108	Spring clasp bracket	1
23	H22-3-8300-104	Spring clasp holder	2
24	H22-6-8305-102	Spring clasp / claw	2
25	651-1-0127-010	Screw 1/2" -12 UNCx1/2"	2
26	661-2-0127-519	Nut W1/2 x 12 UNC	4
27	H22-3-1700-105	Knob	1
28	511-3-0162-031	Washer D31 x 16.2 x 4T	1
29	H22-6-8609-102	L Bracket	1
30	603-3-0130-107	Washer D30 x 13 x 5T	6
31	653-1-0160-205	Bolt - M16 xP2 x90L	4
32	653-2-0160-023	Nut - M16 x P2	4
33	428-4-3100-102	Hose assy.	1
34	90001	Leg assy. (accessory)	1
35	G36-3-3300-106	Support leg	2
36	G36-3-5000-104	Caster	2
37	G36-3-5001-106	Caster with brake	2
38	653-1-0127-308	Bolt	4
39	661-2-0127-601	Nut - nylon	4
40	511-3-0130-101	Washer	8
-	90000-L0	Label	1
-	90000-M0	Manual	1

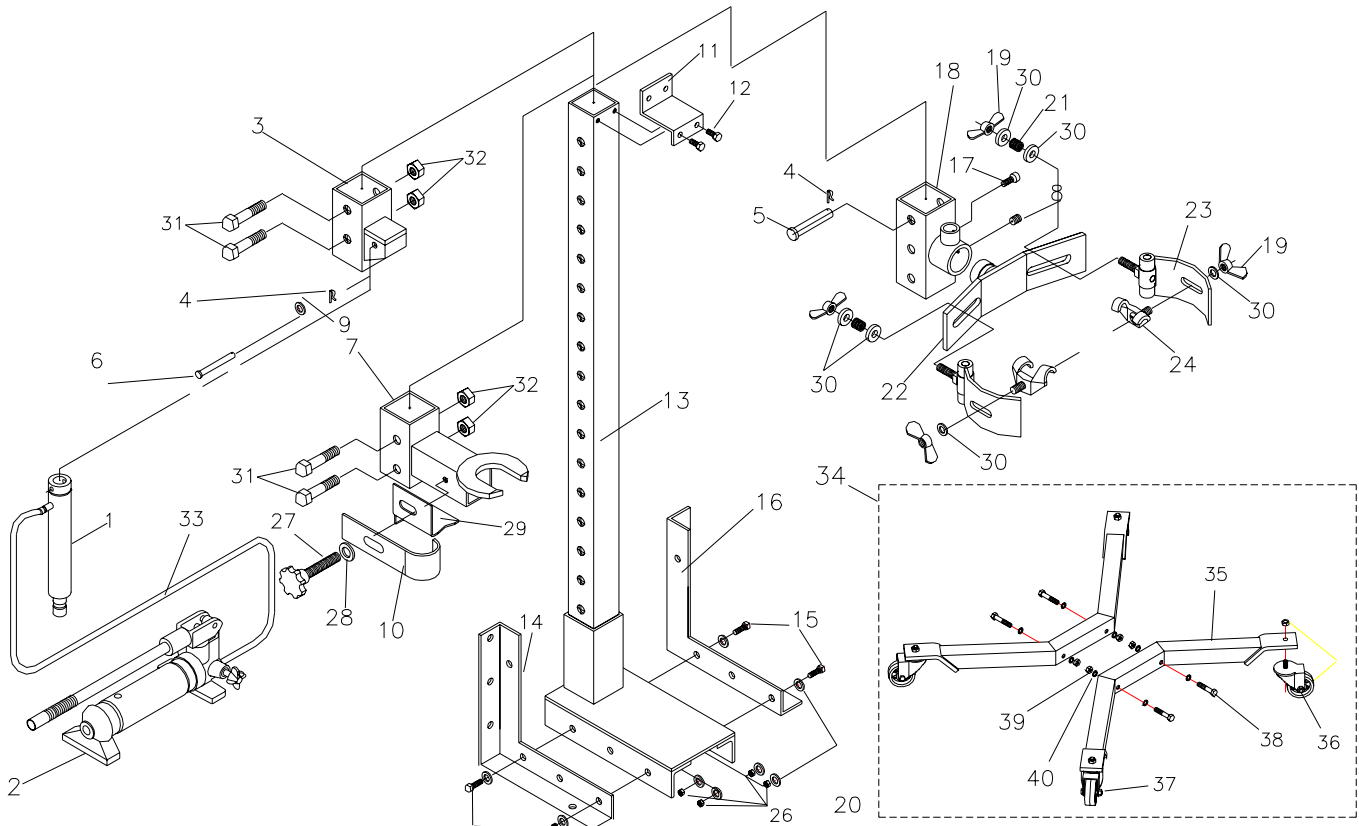

Figure 12 - Replacement Parts Illustration for Model 90000



## ONE YEAR LIMITED WARRANTY

For a period of one (1) year from date of purchase, **SFA Companies** will repair or replace, at its option, without charge, any of its products which fails due to a defect in material or workmanship under normal usage. This limited warranty is a consumer's exclusive remedy.

Performance of any obligation under this warranty may be obtained by returning the warranted product, freight prepaid, to **SFA Companies** Warranty Service Department, 10939 N. Pomona Ave., Kansas City, MO 64153.

Except where such limitations and exclusions are specifically prohibited by applicable law, (1) THE CONSUMER'S SOLE AND EXCLUSIVE REMEDY SHALL BE THE REPAIR OR REPLACEMENT OF DEFECTIVE PRODUCTS AS DESCRIBED ABOVE. (2) **SFA Companies** SHALL NOT BE LIABLE FOR ANY CONSEQUENTIAL OR INCIDENTAL DAMAGE OR LOSS WHATSOEVER. (3) ANY IMPLIED WARRANTIES, INCLUDING WITHOUT LIMITATION THE IMPLIED WARRANTIES OF MERCHANTABILITY AND FITNESS FOR A PARTICULAR PURPOSE, SHALL BE LIMITED TO ONE YEAR, OTHERWISE THE REPAIR, REPLACEMENT OR REFUND AS PROVIDED UNDER THIS EXPRESS LIMITED WARRANTY IS THE EXCLUSIVE REMEDY OF THE CONSUMER, AND IS PROVIDED IN LIEU OF ALL OTHER WARRANTIES, EXPRESS OR IMPLIED. (4) ANY MODIFICATION, ALTERATION, ABUSE, UNAUTHORIZED SERVICE OR ORNAMENTAL DESIGN VOIDS THIS WARRANTY AND IS NOT COVERED BY THIS WARRANTY.

Some states do not allow limitations on how long an implied warranty lasts, so the above limitation may not apply to you. Some states do not allow the exclusion or limitation of incidental or consequential damages, so the above limitation or exclusion may not apply to you. This warranty gives you specific legal rights, and you may also have other rights which vary from state to state.



SFA Companies  
10939 N. Pomona Ave. Kansas City, MO 64153  
888-332-6419  
sales@omegalift.com