

Sinclair Spectrum

APPROVED

This technical manual was OCR'ed for the
Sinclair world by Andy Dansby.
andydansby@yahoo.com

All intellicial information contained
inside this technical manual is the
property of Amstrad.

Thank you Clive for the ZX Spectrum.

SERVICINGMANUAL

FOR

ZXSPECTRUM®

LIST OF CONTENTS

	INTRODUCTION
SECTION 1	SYSTEM DESCRIPTION
SECTION 2	DISASSEMBLY/ASSEMBLY
SECTION 3	SETTING UP AND SYSTEM TEST
SECTION 4	FAULT DIAGNOSIS AND REPAIR
SECTION 5	PARTS LISTS

i LIST OF ILLUSTRATIONS i

Fig No.

ZX Spectrum Block Diagram	1.1
Expansion RAM RAS/CAS Timing (Read Cycle shown)	1.2
Keyboard Matrix Interconnections	1.3
ZX Spectrum (Issue 2) Circuit Diagram	1.4
ZX Spectrum (Issue 3) Circuit Diagram	1.5
Keyboard Format	4.1
Speaker Load Input Waveforms	4.2
Expansion Memory 1C Locations	4.3
Issue 3 Links vs 1C Manufacturer and Type	4.4
Printed Circuit Board (Issue 2) Component Layout	5.1
Printed Circuit Board (Issue 3) Component Layout	5.2
Printed Circuit Board (Issue 3B) Component Layout	5.3

Prepared by THORN (EMI) DATATECH LTD
for SINCLAIR RESEARCH LTD

MARCH 1984

© Sinclair Research Ltd.

- INTRODUCTION

This manual is for use by authorised SINCLAIR dealers, engineers and representatives as a guide to rectifying faults on the SINCLAIR ZX SPECTRUM personal computer.

The manual refers principally to the Issue 2 and Issue 3 Spectrums but provides a background to the Issue 1 version in the section dealing with modification history.

Basic knowledge of ZX SPECTRUM operating procedures is assumed as is knowledge of current workshop practice relating to microcomputers.

NOTE: Essential modifications are required on some Issue 2 Spectrums. Refer to Modification History (Section 4) and implement as necessary.

- SAFETY MEASURES •

This instruction manual contains certain

- WARNING - and _____ CAUTION -

notices which MUST be followed by the user to ensure SAFE operation and to retain the equipment in a SAFE condition.

Any adjustment, maintenance and repair of the opened apparatus under voltage shall be carried out only by a skilled person who is AWARE OF THE HAZARD INVOLVED.

SECTION 1

SYSTEM DESCRIPTION

Sub-Section	LIST OF CONTENTS	Page No.
1	Introduction	1.1
2	Architecture	1.1
3	Z80A CPU	1.2
4	Memory Organisation	1.4
	Read/Write Operations	1.4
5	Input/Output	1.6
	TV Picture Generation	1.6
	Keyboard Scanning	1.8
	Tape Interface	1.10
6	Power Supplies	1.11
	Circuit Diagrams	
	ZX Spectrum, Issue 2	Fig. 1.4
	ZX Spectrum, Issue 3	Fig. 1.5

1. INTRODUCTION

- 1.1 A block diagram of the complete ZX SPECTRUM micro-computer is given in Figure 1.1. It is valid for all build standards, fitted with either 16k or 48k bytes of dynamic RAM memory. Although functionally identical, detailed circuit changes have been introduced to improve reliability and to assist with manufacture. The printed circuit board layout has also been modified. Details of these changes are highlighted where necessary in the following paragraphs, and in later sections referring to fault diagnosis and repair.

2. ARCHITECTURE

- 2.1 The architecture of the Spectrum shown in Figure 1.1 is typical of many microcomputer systems in that it comprises a single microprocessor board (in this instance a Z80A or u780 CPU), a read only memory (ROM), an expandable RAM memory and an input/output section handling the keyboard, tape and TV display functions. The latter is recognisable as the logic gate array (ULA) and the three functional blocks shown in the right of the diagram.
- 2.2 The computer is built on a single printed circuit board which also includes a regulated power supply fed from an external 9V power pack. The keyboard matrix is part of the upper case assembly and is connected to the board via two ribbon cables KB1 and KB2. A description of each section follows.

3. Z80A CPU
 - 3.1 The Z80A is an 8-bit single-IC central processing unit (CPU). It is clocked at 14.0 MHz from an external source controlled by the logic gate array (ULA) and has a standard three bus input/output arrangement. These buses are the Data Bus, Address Bus and Control Bus respectively.
 - 3.2 Data Bus. D7-D10 constitutes an 8-bit bi-directional data bus with active high, tri-state input/outputs. It is used for data exchanges with the memory and with the ULA.
 - 3.3 Address Bus. A15-A0 constitutes a 16-bit address bus with active high, tri-state outputs. The address bus provides the address for memory (up to 64k bytes) data exchanges and for data exchanges with the ULA. It is also used during the interrupt routine (see below) when scanning the keyboard matrix.
 - 3.4 Control Bus. The control bus is a collection of individual signals which generally organise the flow of data on the address and data buses. The block diagram only shows five of these signals although others of minor importance are made available at the expansion port (see Figures 1.4 and 1.5 for details).
 - 3.5 Starting with memory request (\overline{mREQ}), this signal is active low indicating when the address bus holds a valid address for a memory read or memory write operation. Input/Output request (\overline{IORQ}) is also active low but indicates when the lower half of the address bus holds a valid I/O address for the ULA during I/O read/write operations.
 - 3.6 The read and write signals (RD and WR) are active low, and one or other is active indicating that the CPU wants to read or write data to a memory location or I/O device. All the control signals discussed so far are active low, tri-state outputs.
 - 3.7 The last control signal described here is the maskable interrupt (INT). This input is active low and is generated by the ULA once every 20 ms. Each time it is received the CPU 'calls' the 'maskable interrupt' routine during which the real-time is incremented and the keyboard is scanned.
 - 3.8 CPU Clock. Returning to the CPU clock mentioned earlier in this section, the ULA is able to inhibit this input bringing the CPU to a temporary halt. This mechanism gives the ULA absolute priority, allowing it to access the standard 16k RAM without interference from the CPU (see RAM description). Switching transistor TR3 ensures that the clock amplitude is +5V rather than some arbitrary TTL level. This is essential if the CPU is to operate effectively while executing fast machine code programs of the 'space invader' ^'

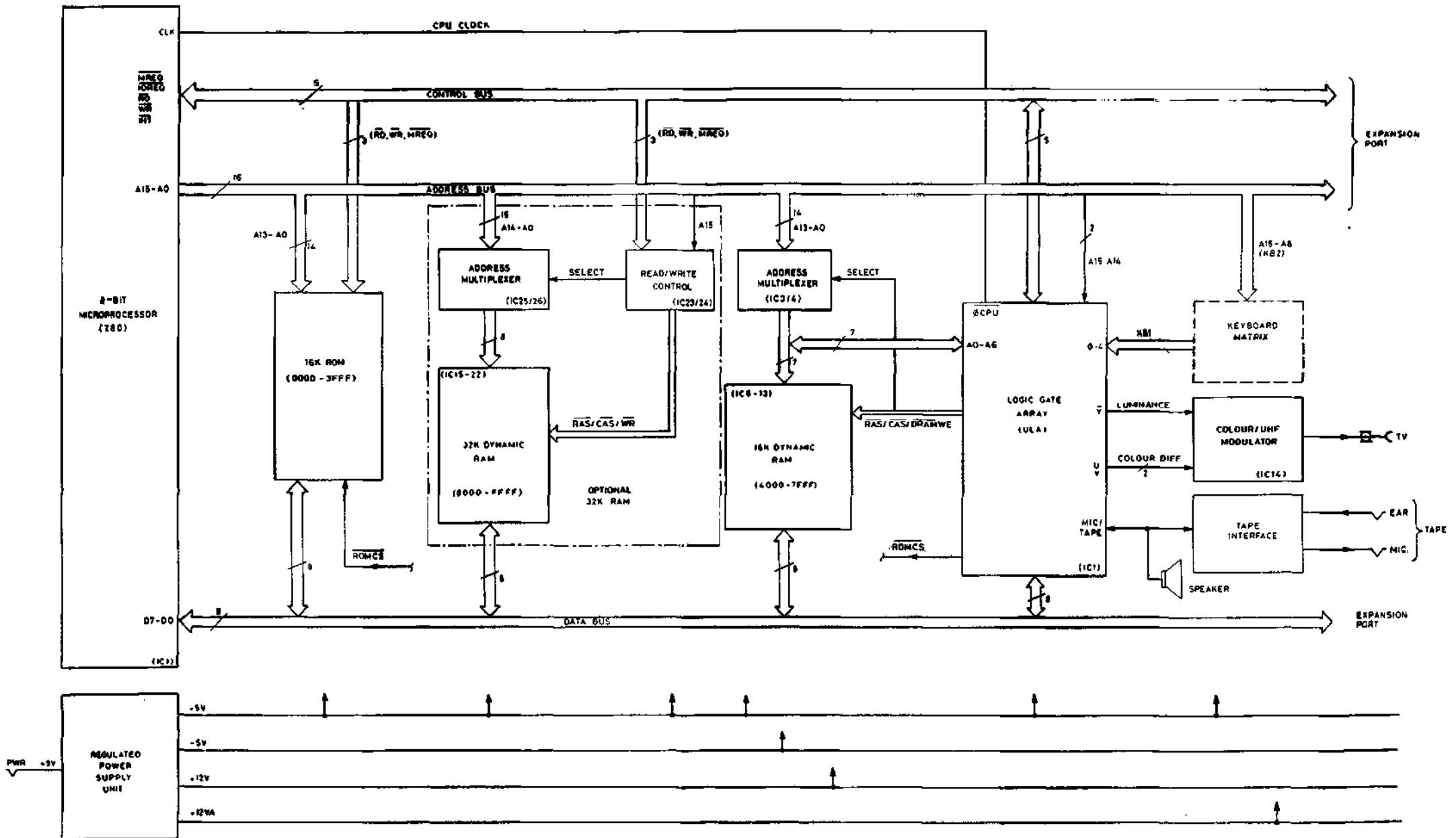

ZX SPECTRUM BLOCK DIAGRAM FIG 1.1

3.9 Dynamic Memory Refresh. The CPU incorporates built-in dynamic RAM refresh circuitry. As part of the instruction OP code fetch cycle, the CPU performs a memory request after first placing the refresh address on the lower eight bits of the address bus. At the end of the cycle the address is incremented so that over 255 fetch cycles, each row of the dynamic RAM is refreshed. This mechanism only applies to the optional 32k expansion RAM in the 48k Spectrum. An alternative refresh method is adapted for the standard 16K RAM.

4. MEMORY ORGANISATION

4.1 In the standard 16k Spectrum there are 32k bytes of addressable memory equally divided between ROM and RAM.

4.2 The lower 16k bytes of memory (addresses 0000 - 3FFF) are implemented in a single ROM (IC5) which holds the monitor program. This program is a complex Z80 machine code program divided broadly into three parts one each covering the input/output routines, the BASIC interpreter and expression handling. Details of the program content, although outside the scope of this manual, are referred to as necessary.

4.3 The upper 16 bytes of memory (addresses 4000 - 7FFF) are implemented using eight 16k bit dynamic RAMs (IC6-IC13). Approximately half of this space is available to the user for writing BASIC or machine code programs. The remainder is used to hold the system variables including 6k bytes reserved for the memory mapped display area.

4.4 In the 48k Spectrum an additional 32k bytes of RAM are provided (addresses 8000 - FFFF) which are implemented using eight 32k bit dynamic RAMs (IC15-IC32). The RAM, providing extra memory space for the user, is normally fitted during manufacture but may be added retrospectively using the RAM expander kit. In addition to the RAMs, the kit includes the address multiplexer and read/write control ICs IC23-IC26. Board space and the necessary discrete components are already provided on the board.

4.5 Read/Write Operations

4.5.1 The following description should be read in conjunction with the circuit diagrams given in Figures 1.4 and 1.5.

4.5.2 Read Only Memory (ICS). The CPU addresses the ROM directly during memory read cycles using the address bus A13-A0. MREQ and RD enable the ROM and the ROM outputs respectively. A third input (CS) derived by the ULA (ROMCS) selects the ROM, provided the higher order address bits A14 and A15 are both low. These are reserved for accessing the RAM memory which starts with address 4000 (i.e. address A14 set). An external ROM 1C select input, supplied via the expansion port on pin 25A, selectively disables the on-board ROM by pulling the select input high. By virtue of R33 placed on the ULA side of the ROM the ULA ROMCS output is effectively inhibited. Interface 1 uses this

100	101	102	103	104	105	106	107	108	109	110	111	112	113	114	115	116	117	118	119	120	121	122	123	124	125	126	127	128	129	130	131	132	133	134	135	136	137	138	139	140	141	142	143	144	145	146	147	148	149	150	151	152	153	154	155	156	157	158	159	160	161	162	163	164	165	166	167	168	169	170	171	172	173	174	175	176	177	178	179	180	181	182	183	184	185	186	187	188	189	190	191	192	193	194	195	196	197	198	199	200
-----	-----	-----	-----	-----	-----	-----	-----	-----	-----	-----	-----	-----	-----	-----	-----	-----	-----	-----	-----	-----	-----	-----	-----	-----	-----	-----	-----	-----	-----	-----	-----	-----	-----	-----	-----	-----	-----	-----	-----	-----	-----	-----	-----	-----	-----	-----	-----	-----	-----	-----	-----	-----	-----	-----	-----	-----	-----	-----	-----	-----	-----	-----	-----	-----	-----	-----	-----	-----	-----	-----	-----	-----	-----	-----	-----	-----	-----	-----	-----	-----	-----	-----	-----	-----	-----	-----	-----	-----	-----	-----	-----	-----	-----	-----	-----	-----	-----	-----	-----	-----

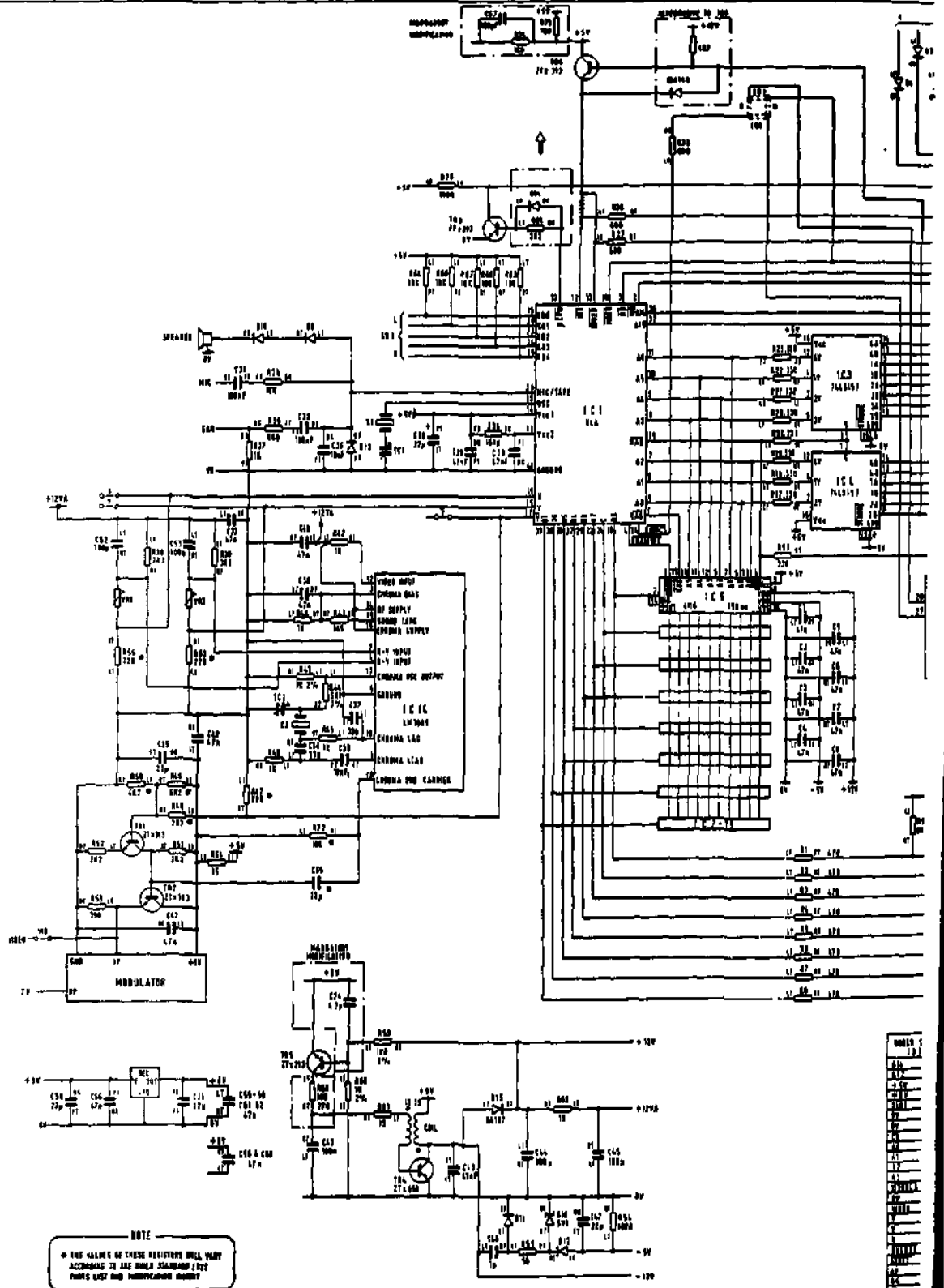

NOTE:
 * THE VALUES OF THESE RESISTORS WILL VARY
 ACCORDING TO THE SINGLE STANDARD 1/2%
 POWER LIST AND MANUFACTURER'S BRANDY

100	101	102	103	104	105	106	107	108	109	110	111	112	113	114	115	116	117	118	119	120	121	122	123	124	125	126	127	128	129	130	131	132	133	134	135	136	137	138	139	140	141	142	143	144	145	146	147	148	149	150	151	152	153	154	155	156	157	158	159	160	161	162	163	164	165	166	167	168	169	170	171	172	173	174	175	176	177	178	179	180	181	182	183	184	185	186	187	188	189	190	191	192	193	194	195	196	197	198	199	200
-----	-----	-----	-----	-----	-----	-----	-----	-----	-----	-----	-----	-----	-----	-----	-----	-----	-----	-----	-----	-----	-----	-----	-----	-----	-----	-----	-----	-----	-----	-----	-----	-----	-----	-----	-----	-----	-----	-----	-----	-----	-----	-----	-----	-----	-----	-----	-----	-----	-----	-----	-----	-----	-----	-----	-----	-----	-----	-----	-----	-----	-----	-----	-----	-----	-----	-----	-----	-----	-----	-----	-----	-----	-----	-----	-----	-----	-----	-----	-----	-----	-----	-----	-----	-----	-----	-----	-----	-----	-----	-----	-----	-----	-----	-----	-----	-----	-----	-----	-----	-----

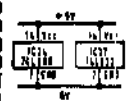
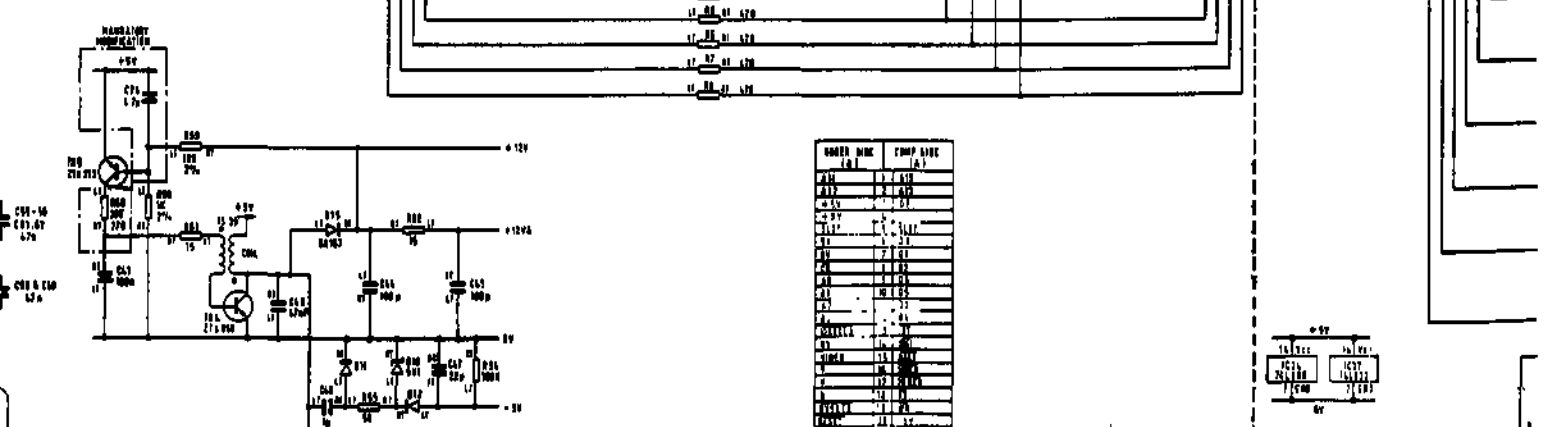
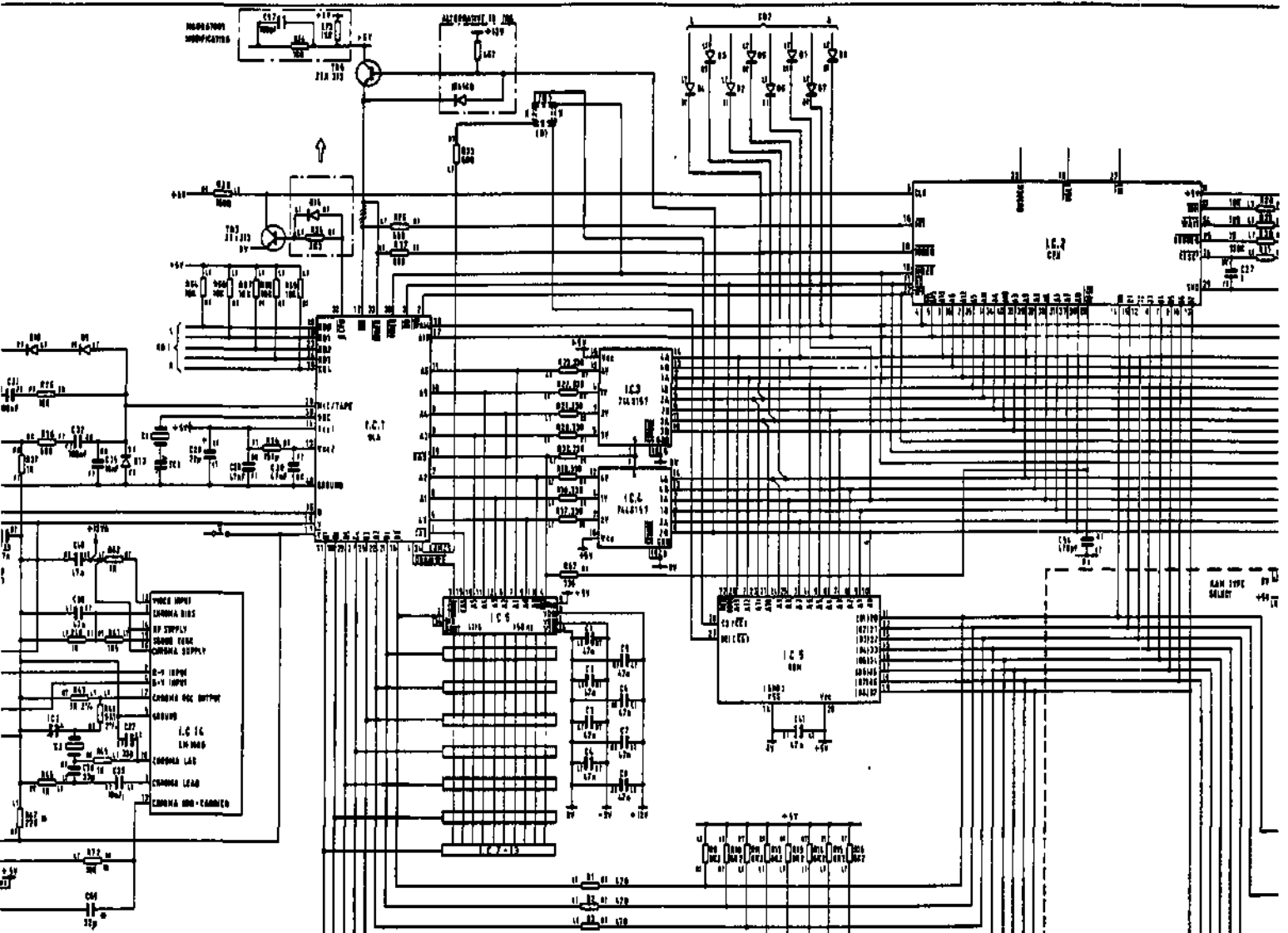
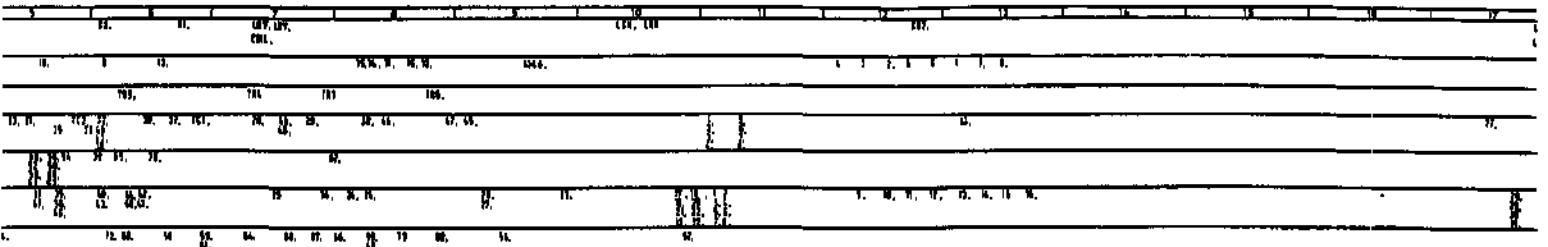

COND	VOLT	CAPACITANCE
41	100	1000
42	100	1000
43	100	1000
44	100	1000
45	100	1000
46	100	1000
47	100	1000
48	100	1000
49	100	1000
50	100	1000

1	2	3	4	5	6	7	8	9	10	11	12	13	14	15	16	17	18	19	20	21	22	23	24	25	26	27	28	29	30	31	32
MISC																															
0																															
FR																															
C																															
I																															

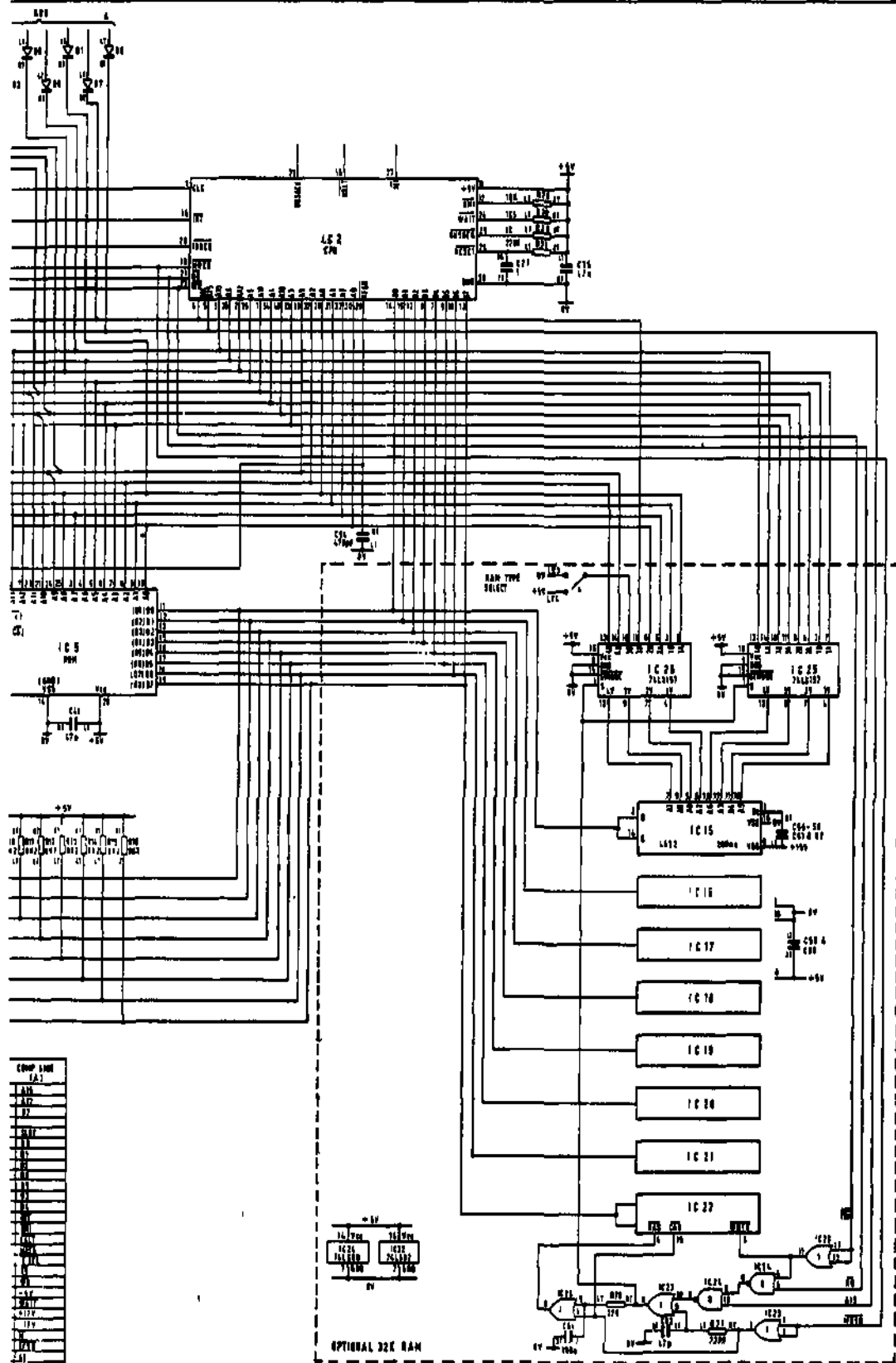

LAST JE No. - 1226
 LAST REV No. - 072
 LAST CAP No. - 466
 LAST DRAW No. - 016
 LAST TRASH No. - 106
 01-014 - 25 014
 ALL OTHERS RESERVED

IC No	MAN REF
1	7400
2	7401
3	7402
4	7403
5	7404
6	7405
7	7406
8	7407
9	7408
10	7409
11	7410
12	7411
13	7412
14	7413
15	7414
16	7415
17	7416
18	7417
19	7418
20	7419
21	7420
22	7421
23	7422
24	7423
25	7424
26	7425
27	7426

COMP LINE	IC
1	7400
2	7401
3	7402
4	7403
5	7404
6	7405
7	7406
8	7407
9	7408
10	7409
11	7410
12	7411
13	7412
14	7413
15	7414
16	7415
17	7416
18	7417
19	7418
20	7419
21	7420
22	7421
23	7422
24	7423
25	7424
26	7425
27	7426

ZX SPECTRUM (ISSUE 2) FIG. 1.4
 CIRCUIT DIAGRAM ESK 12740
 ISSUE 1A

18	19	20	21	22	23	24	25	26	27	28	29	30	31	32	33	34	35	36	37	38	39	40	41	42	43	44	45	46	47	48	49	50	51	52	53	54	55	56	57	58	59	60	61	62	63	64	65	66	67	68	69	70	71	72	73	74	75	76	77	78	79	80	81	82	83	84	85	86	87	88	89	90	91	92	93	94	95	96	97	98	99	100
----	----	----	----	----	----	----	----	----	----	----	----	----	----	----	----	----	----	----	----	----	----	----	----	----	----	----	----	----	----	----	----	----	----	----	----	----	----	----	----	----	----	----	----	----	----	----	----	----	----	----	----	----	----	----	----	----	----	----	----	----	----	----	----	----	----	----	----	----	----	----	----	----	----	----	----	----	----	----	----	----	----	-----

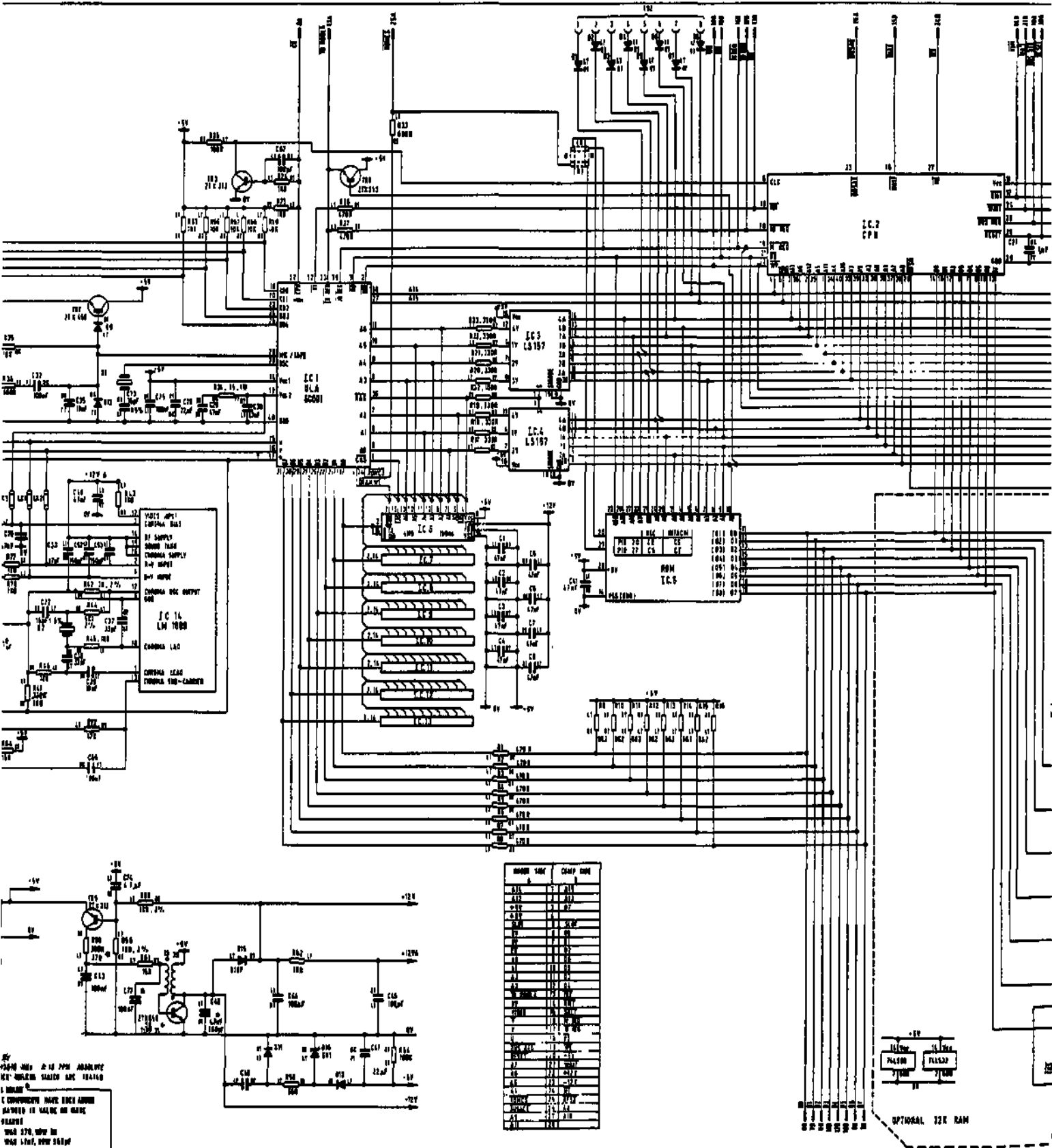

RAM	COMP	COMP	COMP
1	1	1	1
2	2	2	2
3	3	3	3
4	4	4	4
5	5	5	5
6	6	6	6
7	7	7	7
8	8	8	8
9	9	9	9
10	10	10	10
11	11	11	11
12	12	12	12
13	13	13	13
14	14	14	14
15	15	15	15
16	16	16	16
17	17	17	17
18	18	18	18
19	19	19	19
20	20	20	20
21	21	21	21
22	22	22	22
23	23	23	23
24	24	24	24
25	25	25	25
26	26	26	26
27	27	27	27
28	28	28	28
29	29	29	29
30	30	30	30
31	31	31	31
32	32	32	32
33	33	33	33
34	34	34	34
35	35	35	35
36	36	36	36
37	37	37	37
38	38	38	38
39	39	39	39
40	40	40	40
41	41	41	41
42	42	42	42
43	43	43	43
44	44	44	44
45	45	45	45
46	46	46	46
47	47	47	47
48	48	48	48
49	49	49	49
50	50	50	50
51	51	51	51
52	52	52	52
53	53	53	53
54	54	54	54
55	55	55	55
56	56	56	56
57	57	57	57
58	58	58	58
59	59	59	59
60	60	60	60
61	61	61	61
62	62	62	62
63	63	63	63
64	64	64	64
65	65	65	65
66	66	66	66
67	67	67	67
68	68	68	68
69	69	69	69
70	70	70	70
71	71	71	71
72	72	72	72
73	73	73	73
74	74	74	74
75	75	75	75
76	76	76	76
77	77	77	77
78	78	78	78
79	79	79	79
80	80	80	80
81	81	81	81
82	82	82	82
83	83	83	83
84	84	84	84
85	85	85	85
86	86	86	86
87	87	87	87
88	88	88	88
89	89	89	89
90	90	90	90
91	91	91	91
92	92	92	92
93	93	93	93
94	94	94	94
95	95	95	95
96	96	96	96
97	97	97	97
98	98	98	98
99	99	99	99
100	100	100	100

IF
 1. 2. 3. 4. 5. 6. 7. 8. 9. 10. 11. 12. 13. 14. 15. 16. 17. 18. 19. 20. 21. 22. 23. 24. 25. 26. 27. 28. 29. 30. 31. 32. 33. 34. 35. 36. 37. 38. 39. 40. 41. 42. 43. 44. 45. 46. 47. 48. 49. 50. 51. 52. 53. 54. 55. 56. 57. 58. 59. 60. 61. 62. 63. 64. 65. 66. 67. 68. 69. 70. 71. 72. 73. 74. 75. 76. 77. 78. 79. 80. 81. 82. 83. 84. 85. 86. 87. 88. 89. 90. 91. 92. 93. 94. 95. 96. 97. 98. 99. 100.

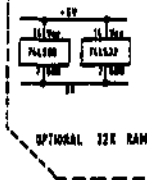

| | | | | | | | | | | | |
|---------------|----|----|----|----|----|----|----|----|----|----|----|
| 12 | 13 | 14 | 15 | 16 | 17 | 18 | 19 | 20 | 21 | 22 | 23 |
| U, W, X, Y, Z | | | | | | | | | | | |
| | | | | | | | | | | | |
| | | | | | | | | | | | |
| | | | | | | | | | | | |
| | | | | | | | | | | | |
| | | | | | | | | | | | |
| | | | | | | | | | | | |
| | | | | | | | | | | | |

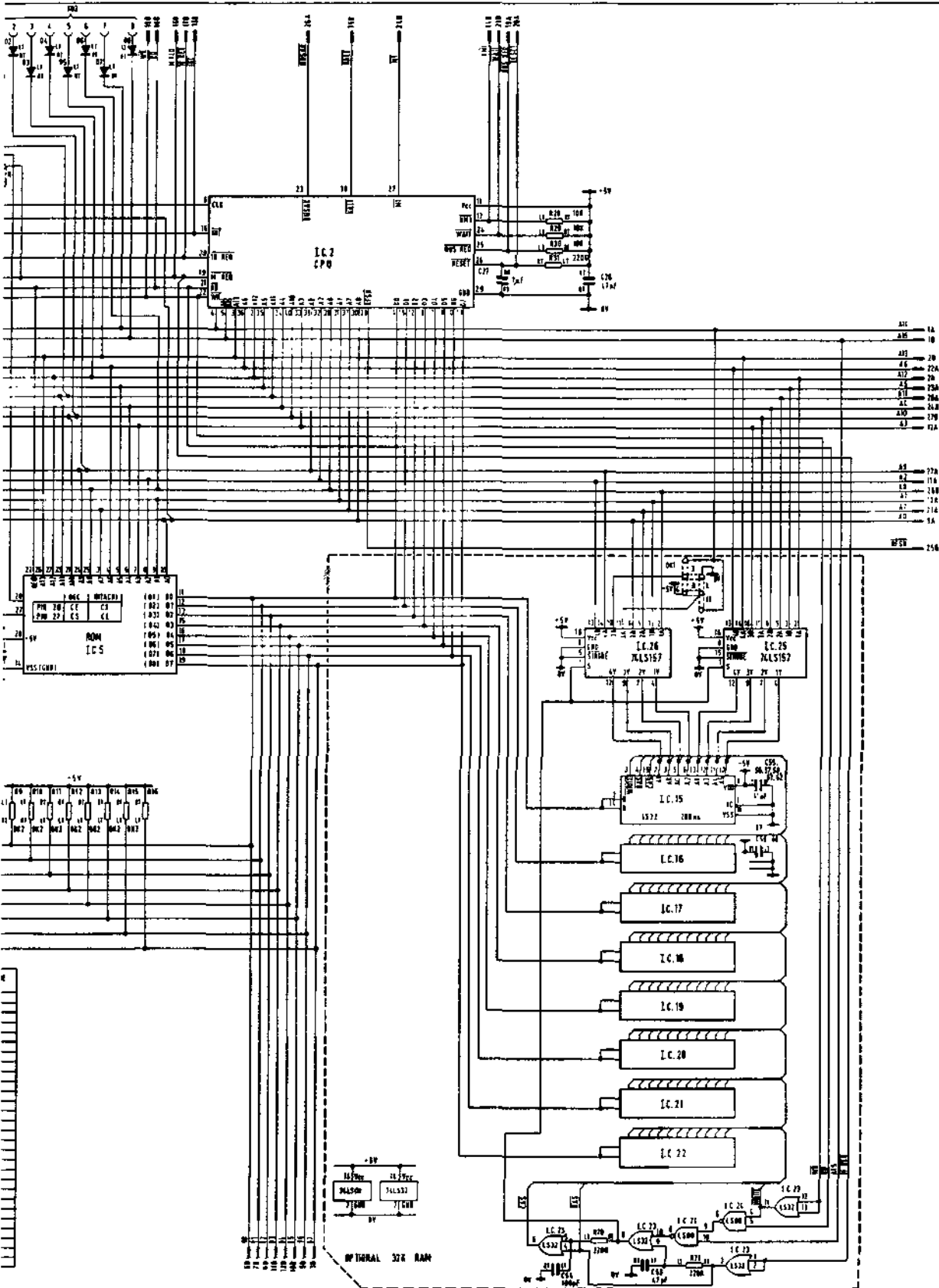

| IC | GPIO REF |
|----|------------------|
| 1 | 2F |
| 2 | 11J |
| 3 | 10C |
| 4 | 10P |
| 5 | 10M |
| 6 | 9F |
| 7 | 9M |
| 8 | 9D |
| 9 | 9E |
| 10 | 9B |
| 11 | 9I |
| 12 | 8I |
| 13 | 8P |
| 14 | 8C |
| 15 | 8A |
| 16 | 8H |
| 17 | 8B |
| 18 | 8D |
| 19 | 8L |
| 20 | 8J |
| 21 | 8M |
| 22 | 8N |
| 23 | 8P, 7F, 10D, 10N |
| 24 | 8D, 8N |
| 25 | 18D |
| 26 | 19D |

ZX SPECTRUM (ISSUE 3) FIG. 1.5
 CIRCUIT DIAGRAM ESK12750
 ISSUE A

mechanism allowing the CPU to read the extension ROM in the interface for microdrive and RS232 applications.

- 4.5.3 Links H and N, shown directly above IC5, allow a second source ROM to be fitted. The Hitachi (H) and NEC (N) ROMs use different pins for the enable and select inputs (i.e. pins 20 and 27). The links allow the inputs to be reversed accordingly.
- 4.5.4 Standard 16k RAM (IC6-IC13). The eight 16k RAM ICs making up the standard 16k x 8 bit RAM memory are organised as a matrix of 128 rows x 128 columns. Thus, separate 7-bit row and column addresses are required to access any one of the locations. These addresses are supplied by the CPU on address bus A13-A0 via an address multiplexer IC3/IC4. The low order address bits A6-A0 give the row address and are selected at the beginning of the memory access cycle when initially the RAS output from the ULA is high. Later, as the row address is latched, RAS goes low selecting the high order address bits A13-A7 giving the column address.
- 4.5.5 The RAS/CAS outputs from the ULA are generated in sequence in response to MREQ and A14 from the CPU. The DRAMWE output, also from the ULA is a decode of the RD/WR waveforms telling the RAM to expect either a read or a write cycle.
- 4.5.6 It is also apparent from the circuit diagram that the ULA can access RAM by generating a set of addresses independent of those generated by the CPU. The address port for the RAM is therefore dualled by the insertion of small value resistors (R17-R23) on the address multiplexer side of the RAM. This ensures that where there is likely to be conflict between the ULA and CPU, the ULA address has priority. Priority is assigned on the basis that the ULA must access the memory mapped display area in the RAM at set intervals in order to build up the video for the TV display. If the ULA is about to access the RAM and it detects either A14 or A15 (i.e. the CPU is also about to access the RAM) the ULA inhibits the CPU clock temporarily halting the CPU memory transaction until its own transaction is completed.
- 4.5.7 Resistors R1 to R8, in series with the data bus lines, perform a similar function to the address port resistors described above. They ensure that the ULA does not 'see' CPU write data while the ULA is accessing the RAM.
- 4.5.8 Refresh for the standard 16k dynamic RAM is accomplished during normal read cycles, i.e. most rows are refreshed each time the ULA accesses the memory mapped display area during picture compilation; the remaining rows are refreshed as a result of other read cycles also known to occur at regular intervals within the refresh period.

4.5.9 32k Expansion RAM (IC15-IC32). The eight 32k ICs making up the 32k x 8 bit expansion RAM are in fact 64k ICs with either row or column drop-out rendering one half of the memory non-functional. In order to accommodate the Texas Instruments RAM (Type TMS 4532) or the optional OKI RAM (Type MSM3732) a set of links are provided, visible on the circuit diagram above the address multiplexer IC25/IC26. These links not only cater for the different manufacturer (Issue 3 Spectrums only) but also allow, in both instances, one of two 1C versions to be selected depending on which half of the RAM (top, bottom, left or right) is functional. The links are respectively TI and OKI (manufacturer - Issue 3 Spectrums only), -3/-4 (TI version) and -H/-L (OKI version - Issue 3 Spectrums only).

NOTE: It is essential when replacing ICs in this area that all RAMs carry the same manufacturers part number and that the links are selected accordingly.

4.5.10 The expansion RAM is organised as a matrix of 128 rows x 256 columns (TI RAMs) or 256 rows x 128 (OKI RAMs). Thus, separate 7/8 bit row and column addresses are required to access any one of these locations. These addresses are supplied by the CPU on address bus A14-A0 via an address multiplexer IC25/IC26. For example, when accessing the TI RAM the low order address bits A6 to A0 give the row address; AR is held low on the -3 version selecting the top half of the memory and high on the -4 version selecting the bottom half. The column address is given by the high order address bits A14-A7.

4.5.11 Row/column address selection and RAS/CAS timing for the RAM is decoded in IC23/IC24 from inputs supplied by the CPU, i.e. address line A15 selecting addresses 8000 upwards, and MREQ heralding a memory read or write cycle. A theoretical timing diagram illustrating the RAS/CAS waveforms is given in Figure 1.2.

5. INPUT/OUTPUT

5.1 The input/output section of the Spectrum is centered round the ULA (IC1). The functions performed within the device include TV video compilation, keyboard scanning and tape input/output. It also derives and controls the CPU clock (<j>CPU) using an external 14 MHz crystal XI, and drives the loudspeaker when a 'BEEP' instruction is being executed. Each of these sections and the supporting circuits are described below.

5.2 TV Picture Generation

5.2.1 The video compilation section of the ULA operates in conjunction with the memory mapped picture display area in the standard 16k RAM, the colour (chrominance) modulator (IC14) and the UHF modulator. This combination produces a high resolution, 24 line x 32 character, eight colour TV display.

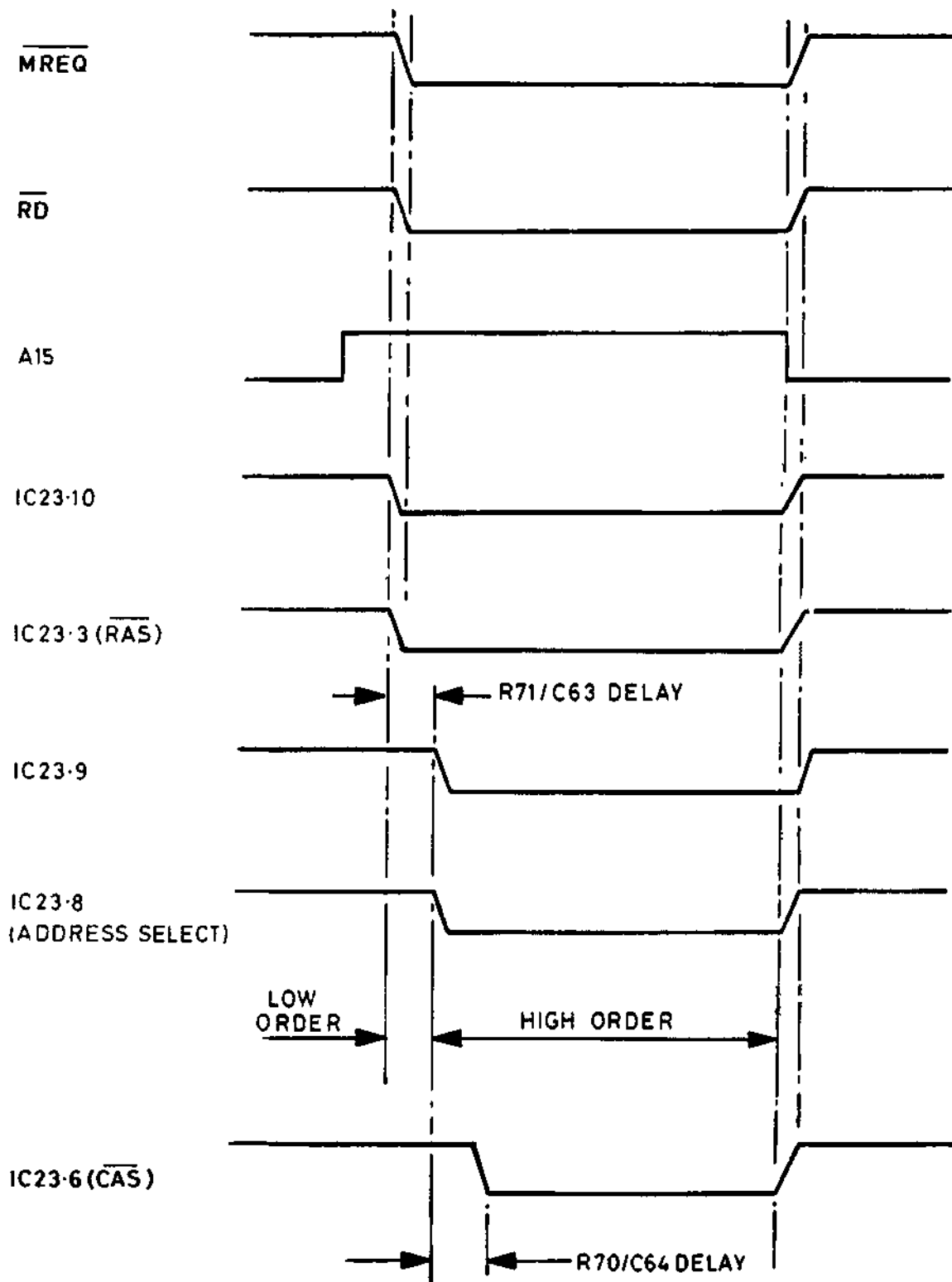

FIG 1.2 EXPANSION RAM RAS/CAS TIMING (READ CYCLE SHOWN)

- 5.2.2 Using the 14 MHz clock the ULA derives line and field timing compatible with the external TV receiver. Video is derived by accessing the memory mapped display area in the RAM in a set sequence at set times throughout the picture frame. The addresses are necessarily independent of the CPU and appear on the ULA address lines A6 through A0 as two separate bytes timed by the RAS/CAS row/column address select lines.
- 5.2.3 The net result is three separate video waveform outputs from the ULA on pins 15, 16 and 17. These carry the luminance signal Y, incorporating the line and field sync, and two unmodulated colour-difference signals U and V making the Spectrum compatible with both colour and monochrome receivers.
- 5.2.4 From the ULA the colour difference signals are applied to the colour modulator IC14 via two level shifting networks. These match the ULA output levels with those required at the B-Y and R-Y inputs to the modulator. In the Issue 2 Spectrum the level shifting network is passive, incorporating two potentiometers VR1, VR2. These are required to set-up the chroma bias level on IC14 pin 3 such that the voltage difference measured between pin 3 and the colour difference signals on pins 2 and 3 respectively is nominally 0V d.c. In the Issue 3 Spectrum two active networks incorporating IRS and TR9 eliminate the potentiometers, greatly improving colour stability.
- 5.2.5 The level shifted colour difference signals, input to IC14, are then encoded, by quadrature modulating two 4.43 MHz chroma sub-carriers. The sub-carriers are generated with the assistance of an external crystal X2 and a CR lead/lag network introducing a 90° phase shift between pins 1 and 18. (A further difference between the Issue 2 and 3 Spectrums lies in the bias oscillator. The early issues incorporate a trimmer TC2 allowing the chroma sub-carrier frequency to be adjusted; on the later issues the frequency is fixed). The resultant modulated colour difference signals are finally mixed producing a composite chroma sub-carrier at IC14 pin 13.
- 5.2.6 At this point the chroma signal is a.c. coupled to the base of TR2 and added to the inverted luminance signal on TR1 collector. The resultant composite video is then buffered and applied to an encapsulated UHF modulator operating on European standard channel 36.

5.3 Keyboard Scanning

- 5.3.1 Every 20 ms (i.e. once per maskable interrupt), the CPU systematically scans the keyboard recording which 'keys' (if any) have been pressed. The scanning method is described below with the aid of Figure 1.3. As the figure clearly illustrates the keyboard consists of an 8 x 5 matrix, the inter-section of each row and column bridged by a normally open switch contact. The row 'outputs' and column 'inputs' are shown connected by separate ribbon cables KB1 and KB2, one to the ULA and the other to the high order address lines A15-A8. Pull-up resistors R64 through R68 ensure that when the address bus is in the high Z state, or none of the key-switches is closed, row outputs KBO to KB4 remain high.

1.9

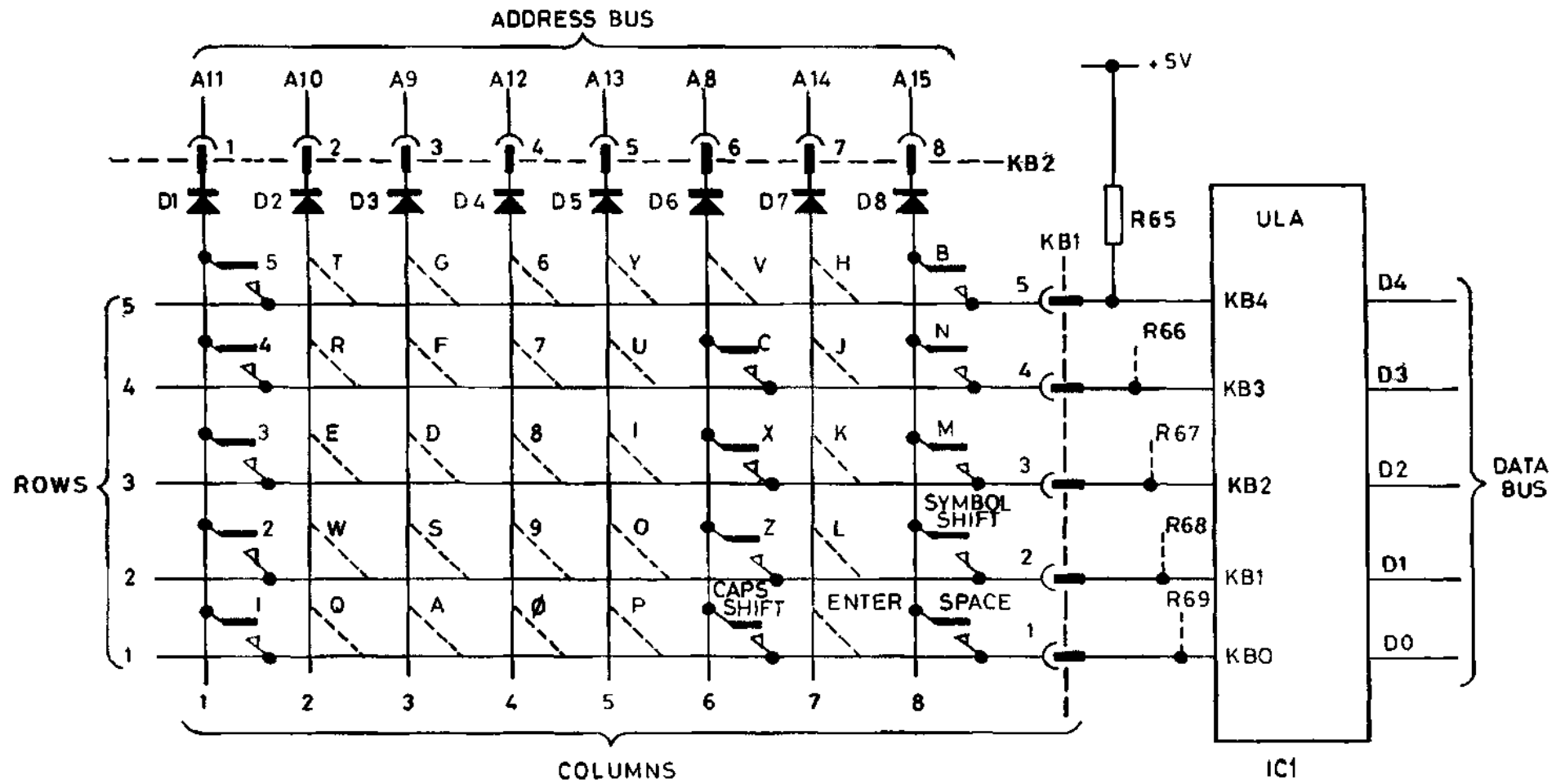

FIG 1.3 KEYBOARD MATRIX INTERCONNECTIONS

5.3.2 When the keyboard scanning routines are entered the CPU performs successive I/O read cycles setting the IOREQ and RD lines to the I/O low. At the same time, the I/O port addresses placed on the upper half of the address bus are modified with each cycle such that each of the address lines A15 through A8 is set low in turn, the other lines remaining high.

5.3.3 The sequence starts with I/O port address FE driving address line A8 low. The keyboard matrix also sees this potential on column 6 applied via D6 and the ribbon cable KB2. Thus, when any of the switches on the inter-section with column 6 is pressed, the corresponding row output supplying the ULA via the second ribbon cable (KB1), is pulled low. The row signal(s) is subsequently inverted by the ULA and placed on one of the five low order data bus lines. For example, if the CAPS SHIFT key is pressed row one output drives data bus DO high and so on. The sequence ends with I/O address 7F when column 8 is addressed. In this instance, operation of the SPACE key drives DO high. Clearly, the keyboard scanning routines make the distinction between the CAPS SHIFT and SPACE key by knowing which address line is being driven.

5.4 Tape Interface

5.4.1 When LOADING or SAVEing programs using a cassette recorder, the ULA transfers information between the MIC and EAR sockets and the data bus, performing A/D and D/A conversions as required. Since the LOAD and SAVE functions are mutually exclusive, a single pin on the ULA (i.e. pin 28) is used both for input and output. Separate I/O read/write cycles to port address 254 configure the pin accordingly. During the LOAD operation the CPU executes successive I/O read cycles, reading the EAR input off data bus 6. When performing a SAVE operation, the CPU executes successive I/O write cycles, this time writing data to the MIC output via data bus 3.

5.4.2 To ensure that I/O cycles are correctly implemented, the IOREQ line supplying the ULA is gated with address line A0 via TR6. Thus, if any memory transactions occur where A0 is high (i.e. not port address 254) then the IOREQ input is forced high inhibiting any attempt to perform an I/O cycle.

5.4.3 Loudspeaker (BEEP) Operation. It should be noted that while SAVEing, the level of the MIC output is barely sufficient to drive the loudspeaker via D9 and TR7 (D10). However, during the execution of a BEEP instruction the CPU writes instead to port 254 on data bus 4. This effectively boosts the MIC output, driving the loudspeaker so that the BEEP tone can be easily heard. During the execution of such an instruction the cassette recorder is not running so there is no conflict at the MIC/EAR sockets.

6. POWER SUPPLIES

- 6.1 The on-board power supply unit receives a 9V unregulated supply from the external Sinclair ZX power pack and derives the following internal supply rails:
- (a) regulated +5V for the 1C logic circuits, the ULA and the UHF modulator,
 - (b) -5V and +12V for the standard 16k dynamic RAM,
 - (c) +12V for the colour modulator circuits.
- 6.2 The external power pack incorporates a mains transformer, full wave rectifier and capacitive smoothing. A thermal fuse is fitted at the transformer input.
- 6.3 The on-board power supply unit incorporates a 7805 regulator, deriving the +5V power rail, and an inverter stage TR4/TR5. The latter raises the level of the +9V unregulated supply to in excess of +12V. The resultant square wave at the junction of TR4 collector and the inverter coil is subsequently rectified and smoothed by D5/C44 producing the +12V output for the RAM. Additional smoothing, imparted by R62/C45, produces the +12V supply for the TV circuits free from noise generated by the RAM. The square wave at TR4 collector also supplies the Zener/rectifier diode combination D16/D12 generating -5V for the RAM, and is available at the expansion port for use by peripherals. The +12V, +5V and -5V are also made available.

SECTION 2

DISASSEMBLY/ASSEMBLY

| Sub-Section | LIST OF CONTENTS | Page No. |
|-------------|------------------|----------|
| 1 | Disassembly | 2.1 |
| 2 | Assembly | 2.1 |

1. DISASSEMBLY

- 1.1 Unplug all input/output leads and turn the computer upside-down to reveal five self-tapping screws. Remove the screws. Hold the two halves of the case together and return the computer to the keys uppermost position. The top half of the case can now be separated from the bottom half, although it remains connected to it by two flexible keyboard ribbon connectors. Care should be taken not to damage the ribbon connectors. As an aid to reassembly, the lie of the connectors within the case should be noted.
- 1.2 To remove the board from the lower half of the case, remove one self-tapping screw (adjacent to IC22 socket) and lift out the board. It may be advantageous to make up two short pluggable extensions for the keyboard connectors in order to improve accessibility to the board.
- 1.3 To change either the keyboard membrane or the rubber keyboard mat it is first necessary to remove the escutcheon plate (template). This is attached to the case by double-sided adhesive tape around the edges. The template is removed by inserting a screwdriver at one end and levering it away from the case. It is not normally possible to remove the template without damage.

2. ASSEMBLY

- 2.1 Assembly is carried out using the reverse procedure to that of disassembly. Do not overtighten self-tapping fixing screws.
- 2.2 When replacing a keyboard component, note that the membrane keys into projections on the case. Place the keypad over the membrane and ensure that it is positioned and seated properly. Faulty installation can result in depressed keys being trapped under the template during subsequent key operations. To install the template, place double-sided adhesive tape around all four edges, locate it in position on the case and apply firm pressure around the edges (12 mm tape on sides and bottom, 6 mm at top).

2.3 When aligning the top half of the case with the bottom half ensure that the two keyboard ribbon cables are not trapped between projecting components within the case. In their correct positions there is sufficient room for the cables to take up a comfortably curved position inside the case. If a cable is trapped and bent double, an open circuit will sooner or later result.

SECTION 3

SETTING UP AND SYSTEM TEST

| Sub-Section | LIST OF CONTENTS | Page No. |
|-------------|------------------------|----------|
| 1 | General Alignment | 3.1 |
| | Introduction | 3.1 |
| | Voltage Check | 3.1 |
| | Colour Adjustment | 3.1 |
| | Sub-Carrier Oscillator | 3.2 |
| | 14MHz Oscillator | 3.2 |
| 2 | System Test | 3.3 |

1. GENERAL ALIGNMENT

- 1.1 Introduction. The Issue 3 Spectrum modification removes the need for adjustment of the colour tuning using potentiometers and trimmers. Therefore, the setting-up procedure for this board is confined to checking that the internally generated power supply voltages and two oscillator frequencies are correct. Adjustment instructions apply strictly to the Issue 2 Spectrum boards only but are generally relevant to the Issue 1 Spectrum as well.

To carry out the setting up procedure it is first necessary to remove the ZX SPECTRUM from the case (Section 2, Assembly/Disassembly). For convenience the keyboard may also be disconnected.

- 1.2 Voltage Check. Check that the internally generated power voltages are as follows:

| Circuit Reference | Nominal Value | Tolerance |
|-------------------|---------------|---------------|
| IC6 pin 9 | + 5V | ± 0.25V |
| IC6 pin 1 | - 5V | - 5.5V to -4V |
| IC6 pin 8 | +12V | ± 1.2V |
| LT side of C52 | +12VA | ± 1.2V |

- 1.3 Colour Adjustment. Potentiometers VR1 and VR2 are used to effectively null the voltages between pins 4 and 2 (for VR1) and pins 2 and 3 (for VR2) on IC14 (LM1889). To allow for thermal drift, the potentiometers are set for non-zero voltages; furthermore these voltage off-sets are set to satisfactory but non-optimum levels in production, and optimum values may be used to advantage in servicing. The relevant figures are given in the following table - voltages are given relative to pin 3 of LM1889.

| Pot. | IC14
Pin No. | Factory Setting
(mV) | Optimum (mV)
Voltage Tolerance | | Overall Range
(mV) |
|------|-----------------|-------------------------|-----------------------------------|-----------|-----------------------|
| VR1 | 4 | 130 ± 20 | +50 | -5 | +45 to +150 |
| VR2 | 2 | 75 ± 20 | -50 | -50
+5 | -45 to -100 |

- 1.4 Sub-Carrier Oscillator. The chrominance sub-carrier oscillator frequency should be 4.433619 MHz ± 50 Hz. This frequency may be checked/adjusted by using one of two methods, listed in (a) or (b) below.

Apply power to the power socket using a bench power supply set at 9V. Current consumption will be approximately 500 mA to 700 mA for the 16k Spectrum and 700 mA to 900 mA for the 48k Spectrum.

- (a) Feed the Spectrum modulator output via a co-axial cable into a standard colour TV receiver. Measure the frequency of the locked TV chroma sub-carrier.
- (b) Connect pin 17 of IC14 (LM1889) via a 4.7 pF capacitor and a lead to the frequency meter. It is recommended that this is done using a jig made up from an IC test clip. Pin 18 of this clip must be removed to minimise stray capacitance. Connect a 10k ohm resistor between the input terminals of the frequency meter. Measure the frequency and adjust trimmer TC2 if the measured frequency is outside tolerance.

- 1.5 14 MHz Oscillator. This frequency is not readily set by working to a specified frequency and tolerance. On Issue 2 boards trimmer TCI should be adjusted to minimise the effects of beat frequencies which cause waves of distortion to flow across the screen. These are particularly apparent with certain colour combinations, e.g. red INK or green PAPER, and the phenomenon is sometimes referred to as 'dot crawl'. It is stressed that adjustment of this frequency is not straight-forward, as deviations due to temperature change are easily visible; tuning should be adjusted to minimise rather than remove this effect. Proceed as follows:

- (a) Set up the Spectrum to display green PAPER with red INK.
- (b) Type-in three or four lines of characters and monitor the screen.
- (c) Adjust trimmer TCI to minimise the effects of distortion.

2. SYSTEM TEST

- 2.1 The system test for the Spectrum may be undertaken using the ZXTP taped program (see 1.1 Test Equipment in Section 4) loaded conventionally; this requires that the keyboard is connected. The test should be carried out with the Spectrum connected to its own power supply.
- 2.2 The test program exercises all of the Spectrum circuitry with the exception of the SAVE function. To test this function a small, possibly one line program should be typed in, SAVED and then VERIFIED as described in the instruction manual.

SECTION 4

FAULT DIAGNOSIS AND REPAIR

| Sub-Section | LIST OF CONTENTS | Page No. |
|-------------|-----------------------------------|----------|
| 1 | Introduction | 4.2 |
| | Test Equipment | 4.2 |
| | Modification History | 4.3 |
| | Modifications - Issue 1 Board | 4.4 |
| | Modifications - Issue 2 Board | 4.5 |
| | 32k Extension Memory - (16k-48k) | 4.5 |
| | Hitachi vs NEC ROM | 4.6 |
| 2 | Fault Diagnosis | 4.6 |
| | Techniques | 4.6 |
| | Power Supply Unit | 4.7 |
| | Initialisation | 4.7 |
| | Memory Check | 4.8 |
| | Keyboard Structure | 4.10 |
| | Fault-Finding Guide | 4.11 |
| 3 | Repair | 4.19 |
| 4 | 16k to 48k Upgrade | 4.19 |
| | Integrated Circuits/Link Settings | 4.19 |
| | Issue 2 Board | 4.20 |
| | Issue 3 Board | 4.20 |

1. INTRODUCTION

1.1 Test Equipment

Section 4 is intended as a guide to fault diagnosis and repair of the ZX SPECTRUM. It is assumed that users have a reasonable knowledge of electronic servicing, theory and standard fault-finding techniques and have access to the test equipment and tools required to carry out the task. The table below contains a list of the minimum recommended test equipment and materials.

| EQUIPMENT | SPECIFICATION/MANUFACTURER |
|---|--|
| Oscilloscope with
Oscilloscope probe (x10) | Rise Time: 0.02 us/cm |
| Variable power supply unit | 0 to 30V d.c. |
| Mono cassette recorder | With RECORD and PLAYBACK facilities |
| Mains extension lead | 'Safebloc' type |
| Multimeter | General purpose |
| Colour Television | Open Market |
| ZX Printer | Sinclair |
| ZXTP test tape | |
| Blank tape | Open Market |
| Double-sided adhesive tape | 12mm and 6mm wide, Tesafix 959
(B.D.F. TESA) or 3M equivalent |

Engineers who are already familiar with the Sinclair ZX81 will find some similarities in the ZX SPECTRUM. The Spectrum, however, is a more sophisticated device with colour and sound circuitry.

The ZX SPECTRUM is supplied with either 16k or 48k of on-board RAM. The 16k version is wired so that it can be expanded to 48k by the addition of a number of appropriate plug-in ICs. For details of the memory upgrade, see sub-section 4 of this section.

See Section 5, Figures 5.1 and 5.2 for the layouts of the Issue 2 and Issue 3 boards respectively.

1.2 Modification History

Two major modifications have been implemented on the Spectrum boards:

- (a) A modified layout of board (i.e. Issue 1, Issue 2 and Issue 3)

Issue 1. This layout allowed for the 16k RAM to be mounted direct on the board, with the 32k extension consisting of a subsidiary board mounting onto special OIL connectors. Approximately 26,000 units were manufactured.

Issue 2. This layout allows for all 48k of RAM to be mounted direct on the board; sockets, ready for a memory update, are fitted on 16k versions. A small number of Issue 2 units were manufactured using disc capacitors for 47 pF and 100 nF values, but subsequently axials were introduced.

Issue 3. This layout incorporates advanced circuitry for the colour tuning, removing the need for potentiometers and trimmers and the associated adjustment. It also allows for OKI ICs to be used in the 32k extension memory. The heatsink is also redesigned and is relocated at the back of the case.

- (b) The Ferranti ULA, type 5C102, plus spider addition replaced by ULA type 5C112.

5C102. This ULA has a timing fault which was cured by connecting a 74LS00 IC mounted on a miniature board and spider. This ULA was fitted to approximately 40,000 units.

5C112. This improved ULA has no spider modification, but has either a diode or resistor or transistor connected to it. The details are:

Diode/resistor mod : 4k7 resistor from +12V to pin 30 on IC2 and diode (IN 4148) from pin 30 of IC2 to pin 33 of IC1.

Transistor mod : TR6 (ZTX313) connected as follows:

Base to IC2, pin 30.

Emitter to IC1, pin 33.

Collector to IC2, pin 11.

6C001 This ULA alters the timing of the colour burst signal, and improves the performance of the Spectrum with certain television sets (e.g. Hitachi, Grundig). It also causes the screen picture to be shifted by one character width to the left.

NOTE: The values of certain components vary depending on which board and which ULA is used as follows:

| Board Issue No | 2 | 2 | 3 |
|----------------|-------|--------|-------|
| ULA Type | 5C112 | 6C001 | 6C001 |
| Component | | | |
| R 47 | 220 a | 1k | 1k |
| R49 | 8 k2 | 10 k | 10 k |
| R56 | 220 n | 470 fi | 1k |
| R63 | 220 n | 470 n | 1k |

1.3 Modifications - Issue 1 Board

A number of modifications were introduced, and these should be checked for and, if necessary, introduced retrospectively:

- (a) 100 pF capacitor between RAS and ground - necessary only when using ULA 5C102.
- (b) 470 pF capacitor between IC2, pin 28 and ground - required only when IC2 and RAM ICs are all of NEC manufacture.
- (c) 1 k resistor between RAS and 23V and 1 k resistor between CAS and 12V, only when RAM ICs are of National manufacture. R57 (330n) must be removed, and the 470 pF capacitor is not required.
- (d) 47 k resistor between pin 13 of LMI889 and ground - required only if the difference between white and yellow colours is inadequate.
- (e) If disc capacitors are used for C41 and C49 (47 nF) they must be replaced by axial components.
- (f) Capacitor C46 (1 uF electrolytic) should be replaced by a high temperature component.
- (g) This modification is required for efficient operation of certain machine code software and should be implemented on all units. It has been implemented in manufacture for all ULAs 5C112-2 and later.

D14 replaced by C67 (100 pF)
R24 changed from 3k3 to 1k
R27 changed from 680 n to 470 n
R73 (1k) added between Id/32 and +5V

- (h) A significant cause of problems has been found to be failure of the internal power supply transistor TR4. The circuit may be improved by changing the value of R60 from 100 n to 270 fl and connecting a 4.7 uF electrolytic (preferably radial type) with positive end to TR5 emitter (positive end of C34) and negative end to TR5 base (to R58).

1.4 Modifications - Issue 2 Board

A number of modifications have also been introduced for the Issue 2 board. These should be checked and, if necessary, introduced retrospectively.

- (a) These components should be changed if colour quality needs upgrading:

R48 changed from 4k7 to 2k2
R49 changed from 18 k to 8k2
R50 changed from 8k2 to 4k7
R72 changed from 47 k (or 18 k) to 10 k
C65 changed from 100 yF to 22 yF

- (b) Early Issue 2 boards were manufactured using a considerable number of 47 yF and 100 uF disc capacitors. C41 (47 nF) and C43 (100 nF) should be replaced with axial components to prevent undue risk of short circuits.

- (c) To prevent lifting of the keyboard template, a thin strip (6 mm wide) of double-sided tape was introduced to the top edge of the template. (Previously, only the other 3 edges had tape). This modification should be introduced whenever template lifting is found to be a problem.

- (d) See Items 1.3(g) and (h) above.

1.5 Modifications - Issue 3B Board

Although functionally similar to the Issue 3 board, the layout differs. The DC converter design has been improved, providing greater power supply reliability. Component changes are as follows (see Fig 1.5 for details):

C77 (1Q0nF) added
C49 changed from 47nF to 560pF
R60 changed from 270fl to 68n
TR4 can be either ZTX650 or TIP31

1.6 32k Extension Memory - (16k to 48k)

Board Issue 1: The extension memory is supplied as a plug-in module which is inserted into sockets near the edge connector. The ICs used are either TI 4532-3 or TI 4532-4, and all ICs in a unit must be of the same type (i.e. all must be -3 or all must be -4).

Board Issue 2: The extra memory is obtained by plugging in 4 logic ICs and 8 memory ICs (see Sub-Section 4). The ICs used are either TI 4532-3 or TI 4532-4, and all ICs must again be of the same type. It should be noted that the RAM select signal is 0V for the -3 IC and +5V for the -4. A link on the board provides the required select level.

Board Issue 3: This allows OKI ICs to be used in place of TI 4532. Again, all ICs must be of the same designation. Appropriate links (2) must be fitted in the grid located on the board between the edge-connector and the 'mic' jack socket. Again the extra memory is obtained by plugging in 4 logic ICs and eight memory ICs.

1.7 Hitachi vs NEC ROM

During manufacture, wiring links are selected and inserted in the board according to whether a Hitachi or NEC ROM is used. These links are marked 'H' and 'N' as appropriate and are located as follows.

Board Issue 1 - between the ROM and the heatsink

Board Issue 2 - beneath the raised portion of the heatsink

Board Issue 3 - adjacent to the loudspeaker

Clearly, if the ROM is changed for one of a different make, then these links must be changed as well.

2. FAULT DIAGNOSIS

2.1 Techniques

In a closed loop system such as a computer, because of the interdependence of numerous component parts, fault diagnosis is not necessarily straight-forward. In addition, because of the high speed cyclic operation, interpretation of any waveforms on control, data and address lines as being valid depends to a large extent on practical experience of the system. There are however, certain checks with valid waveforms and levels that can be carried out before substituting any integrated circuits. Experience has shown that the best method of initially checking waveforms and levels can be to compare with the same point in a known serviceable board. The following pages provide a basic fault-finding procedure and furnish a list of possible faults along with suggested ways of curing them.

With a densely populated board such as the ZX SPECTRUM, a careful physical examination of the board can sometimes indicate an obvious fault. Burst-out discrete components or an overheated track show up immediately, as do the attentions of an enthusiastic amateur. Bearing in mind the latter, short ^circuits, caused by hairline solder splatter can be or several ohms resistance and can cause some very misleading fault symptoms.

Provided first principles are adhered to and a common-sense approach is adopted, it will be found after a short space of time that fixing a faulty Spectrum is very much a routine operation.

2.2 Power Supply Unit

The unstabilised external power supply unit is a source of some problems. The design is such that, at minimum input voltage (215V a.c.) and 1.4A output, the voltage trough should not be less than 7.0V; at maximum input voltage (265V a.c.) and 600mA output, the voltage peak should be less than 13V.

2.3 Initialisation

At switch-on the computer should automatically 'initialise' and produce a clear screen with the statement

(01982 Sinclair Research Ltd

displayed in the lower left section of the screen. This indicates that most of the system is working. If the Spectrum does not initialise, carry out the following basic checks.

Basic Checks. It is difficult to be specific in a fault-finding guide because of the large variety of fault conditions which can occur, but the following procedure, starting with a table of checks set out in order of priority, will however isolate the major fault area.

| FUNCTION | CIRCUIT REF. | WAVEFORM/VOLTAGE |
|--|---|--|
| Voltage regulator input | +ve side of C50 | +9V d.c. \pm 2.0V. At less than +7V the regulator may not operate correctly. |
| Voltage regulator output | +ve side of C34 | +5V d.c. \pm 0.25V - no discernable ripple. |
| On-board power supply outputs: | | |
| +5V d.c. | IC6 pin 9 | +5V d.c. \pm 0.25V - no discernable ripple. |
| -5V d.c. | IC6 pin 1 | -5V d.c. |
| +12V d.c. | IV6 pin 8 | +12V d.c. |
| +12VA(to IC14 only) | LT end of C52 | +12V d.c. |
| Clock pulses | IC1 pin 32
TR3 base and collector
IC2 pin 6 | 14MHz squarewave at +5V amplitude, |
| Address and data lines (following through to relevant ICs) | RT side of R17-R23
RT side of R1-R8 | Waveform of amplitude 3.5V |

If these tests prove satisfactory check IC1 pin 14, IC2 pin 11 and IC5 pin 28 for +5V. Also check for ground at IC1 pin 40, IC2 pin 29 and IC5 pin 14. If all is still satisfactory at this point and IC1 is the plug-in type, replace IC1. If replacement of IC1 does not cure the fault, check the address and data lines of IC1, IC2 and IC5 for active data.

It is possible that one of the Z80A or RAM control lines has become faulty therefore, comparing with a known serviceable board if possible, check the waveforms at the following points at origin and destination:

- | | | |
|-----------|----------------|-----------------|
| (a) IC2: | Pin 16 - INT | Pin 17 - NM1 |
| | Pin 20 - IDREQ | Pin 24 - WAIT |
| | Pin 19 - MREQ | Pin 25 : ffCTEQ |
| | Pin 21 - M | Pin /b KtbM |
| | Pin 22 - WR | |
| (b) IC22: | Pin 4 - "RAT | Pin 3 - WITE |
| | Pin 15 - CA3~ | |

If no fault has been found and the computer still has not initialised, the fault could lie in the RAM. If the computer is a 48k machine the 32k of expansion RAM can be isolated. An easy way of doing this, assuming that the ICs are not fitted into sockets, is to remove the +5V from IC25. This is probably best done by very carefully cutting the track to IC25 pin 16. If this operation clears the fault condition, the expansion RAM will have to be further isolated. In either instance the point has been reached where it is necessary to start replacing ICs.

Where the fault persists after isolating the 32k expansion RAM it would be necessary to start changing individual ICs in the order of IC13 to IC6 (RAM), IC1 (ULA), IC2 (Z80A). After each change of IC the unit must be powered up to check for correct initialisation.

A method of fault-finding that can be used on both the 16k and 48k versions is to make up a 'test IC' device. This may be done by using an IC test clip, to which is attached a serviceable IC (of the relevant type e.g. 4116 or 4532), to bridge across each suspect IC in turn. This method is not guaranteed to work but can often save a lot of time unnecessarily changing suspect ICs.

Memory Check

Where a Spectrum has initialised correctly but a RAM memory fault is suspected, it is possible to find the faulty address and relate it to a faulty IC by carrying out the following procedure:

Key in the instruction:

```
PRINT PEEK 23732 + PEEK 23733 * 256
```

The value printed should be:

- (a) for a 48k unit - 65535
- (b) for a 16k unit - 32767

The value printed in each instance is the last valid memory location, and in a serviceable unit would be as set out above. Therefore, if a different value, n, is printed the faulty location will be n + 1. If the value returned is less than 32767 the fault lies in the original 16k of RAM. The following example illustrates the method of relating a faulty location to a faulty IC.

Example. If a 48k Spectrum is giving a memory of 25.25k key in the following instruction:

```
PRINT PEEK 23732 + PEEK 23733 * 256
```

Assume the answer displayed is 43200, therefore the faulty location is 43201 (stops at last valid location). Key-in:

```
POKE 43201,85 : PRINT PEEK 43201 (= answer A)
```

If answer A is 85, key-in:

```
POKE 43201,170 : PRINT PEEK 43201 (= answer B)
```

If answer B is anything other than 170 look up in the following table which IC to change (e.g. if answer B is 234 change IC21). Similarly, if answer A is other than 85 refer to the table to find the faulty IC.

| Data 85
IC6-IC13 | Data 170
IC15-IC22 | Size of
Error | Error
Bit | Faulty RAM location if:
< 32767 > 32767 | |
|---------------------|-----------------------|------------------|--------------|---|------|
| 84 | 171 | 1 | 0 | IC6 | IC15 |
| 87 | 168 | 2 | 1 | IC7 | IC16 |
| 81 | 174 | 4 | 2 | IC8 | IC17 |
| 93 | 162 | 8 | 3 | IC9 | IC18 |
| 69 | 186 | 16 | 4 | IC10 | IC19 |
| 117 | 138 | 32 | 5 | IC11 | IC20 |
| 21 | 234 | 64 | 6 | IC12 | IC21 |
| 213 | 42 | 128 | 7 | IC13 | IC22 |

If there is more than one faulty RAM location the first fault identified will have to be repaired before it is possible to proceed.

2.5 Keyboard Structure

The keyboard is connected horizontally in eight blocks of five keys each. Figure 4.1 shows the configuration. It follows that if any block of five keys fails the fault is with KB2 circuitry or the 8-way membrane, and that if any block of eight keys fails the fault is with KB1 circuitry or the 5-way membrane. Possible keyboard faults are listed in paragraph 2.6

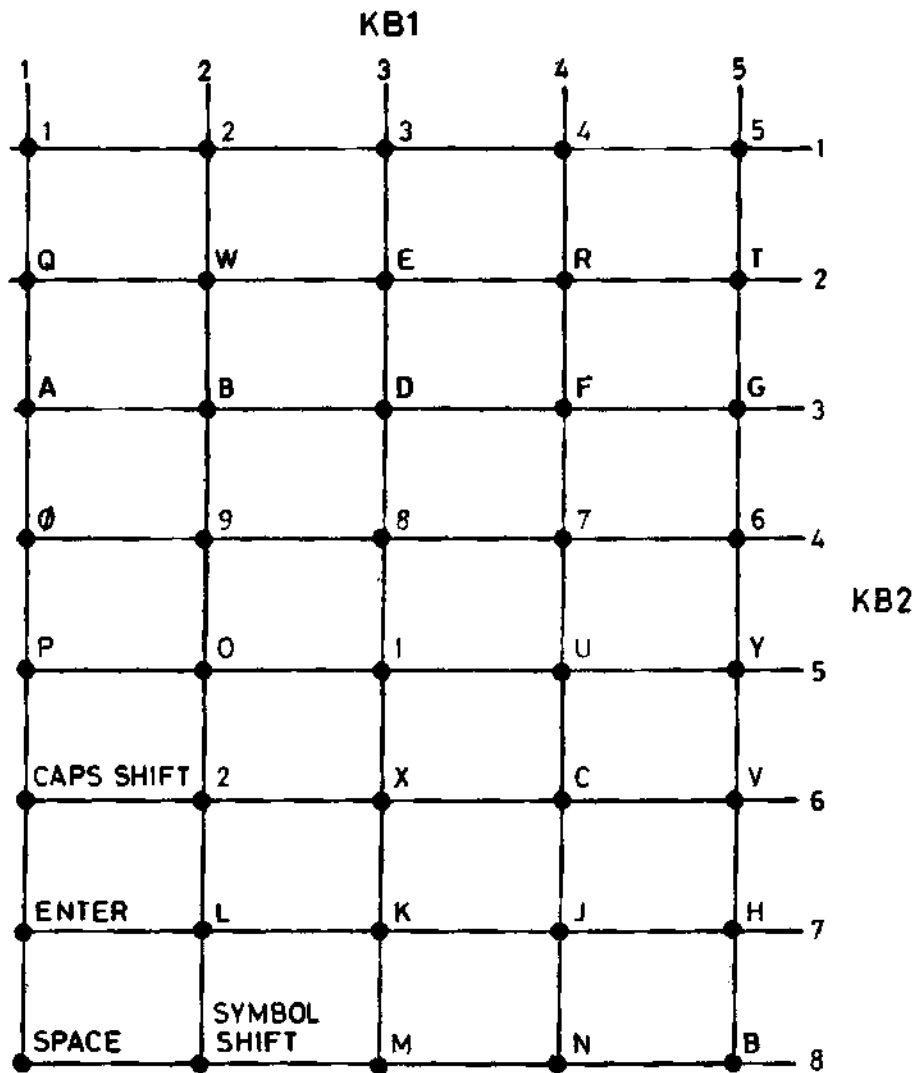





FIGURE 4.1 KEYBOARD FORMAT

2.6 Fault-Finding Guide

As with any complex digital equipment the possible fault permutations are vast, thus the following table is not intended to be an exhaustive list of the faults that might occur on the Spectrum. It is intended as a guide only to possible courses of action to follow when faults show up in particular areas of the circuit. These areas are listed in the table with sub-headings, in no particular order of priority. It is envisaged that the ZOTP test tape has been loaded, or an attempt has been made to load the tape, in order to check for a faulty condition.

| AREA | SYMPTOM | ACTION |
|---|---|--|
| TV screen dead, smoke appears on switch-on. | TR4 base-collector shorted. | Remove TR4 |
| | Short persists with TR4 removed. | <ol style="list-style-type: none"> 1. Check TR5 and C44. 2. Visually check track. 3. Check TR4. |
| | TR4 blows again. | <ol style="list-style-type: none"> 1. Change TR4 and TR5 (even though TR5 checks out). 2. Check that TR5 circuit components are to latest specification. |
| Not initialising. | No '(C)1982 Sine!air. Research Ltd statement. | Follow fault-finding procedure, paragraph 2.2 above. |
| No video. | No video. | <ol style="list-style-type: none"> 1. Change IC1. 2. Check TR1 and TR2. |
| NOTE: Table 4.1 sets out typical signals found on IC14 pins 1-18
IC14 pins 1-18. | No video after ULA changed. | <ol style="list-style-type: none"> 1. Visually check IC1 and socket, 3. Check for shorting between C65 and R53. 4. Carry out fault-finding procedure, para 2.2 above. |
| | | <ol style="list-style-type: none"> 1. Check voltage drop across R64. 2. Check +5V regulator O/P and +9V regulator I/P. 3. Check PWR socket not shorted. 4. Check power unit. |

| AREA | SYMPTOM | ACTION |
|----------------------------------|--------------------------------|--|
| No video, (contd) | No VIDEO INPUT at IC14 pin 12. | <ol style="list-style-type: none"> 1. Check waveform at IC14 pin 13. If correct check TR1 and TR2. 2. Check waveforms at IC1 pins 15, 16 and 17: <div style="margin-left: 20px;"> <p>PIN 15 </p> <p>PIN 16 </p> <p>PIN 17 </p> </div> <p>If correct check VR1, VR2 (Issue 1 and Issue 2 boards).</p> 3. Change IC1. 4. If +5V and VIDEO INPUT correct change modulator. |
| Corrupt Paper, after ULA change. | - | <ol style="list-style-type: none"> 1. Check IC1 socket. 2. Check PWR socket is not intermittent. 3. Check IC1 pin 14 for +5V with no discernible ripple. |
| | No 3 MHz at IC2 pin 6. | <ol style="list-style-type: none"> 1. Low amplitude - check R25. 2. Check TR3. 3. Check IC1 pin 32 for 3 MHz. 4. Check IC1 pin 39 for 14 MHz. 5. Check crystal XI. 6. Check IC1 pin 13 for +3V. |

| AREA | SYMPTOM | ACTION |
|---|--|--|
| Video Incorrect. | Dark Screen. | <ol style="list-style-type: none"> 1. Check tuning. 2. Change modulator. |
| | Dim 'Sinclair' Io9°- | <ol style="list-style-type: none"> 1. Check +12V" 2. Check C65 for high impedance. 3. Check R52. 4. Check +5V on IC14 pin 3. |
| | Wavy lines across screen. | <ol style="list-style-type: none"> 1. Press down on each electrolytic capacitor to see if lines disappear. If so change that capacitor. 2. Check crystal X2. 3. Check/change TR1 and/or TR2. 4. Check/change IC14. |
| | Self resetting. | Check TR6. |
| | Random dynamic squares. | Change C54. |
| | Paper area too low. | Change IC1. |
| | Diagonal lines in the border area. | Change R47. |
| Colour tuning faults (Issue 1 and Issue 2 boards) | Distorted video. | <ol style="list-style-type: none"> 1. Check for +3V at IC1 pin 13. 2. Change C30. |
| | - | Visually check IC14 circuits. |
| | VR1 or VR2 fails to adjust IC14 pin 13 waveform. | <ol style="list-style-type: none"> 1. Monitor IC14 pin 2 trimming VR2. 2. Monitor IC14 pin 4 trimming VR1. 3. Change IC14. |

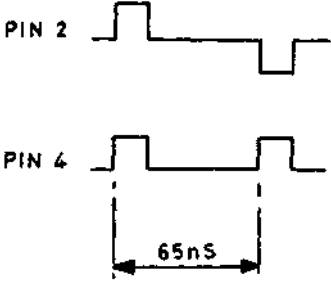
| AREA | SYMPTOM | ACTION |
|--|--|---|
| Colour tuning faults, (cont'd) | VR1 or VR2 d.c. shifts IC14 pin 13 waveform. | Change IC14. |
| | Alternate dark lines on screen. | Change IC14. |
| | No colour after trimming TC2: | |
| | ICH pin 17 not oscillating | <ol style="list-style-type: none"> 1. Check crystal X2. 2. Change ICH. 3. Change X2. |
| | ICH pin 17 oscillating but fails to tune. | <ol style="list-style-type: none"> 1. Check for broken track, 2. Change TC2. 3. Change ICH. |
| | ICH pin 17 output correct but still no colour (boards at all Issue Nos). | <ol style="list-style-type: none"> 1. With 'Sinclair' logo on screen ICH pin 2 and ICH pin 4 should be as follows: |
| | |  |
| | | <ol style="list-style-type: none"> 2. If ICH pins 2 and 4 are correct, change modulator. |
| Colour faults (Issue 1 - Issue 3 boards. | Pin screen. | Change crystal X2. |
| | Blue haze around 'Sinclair1' ^{*_TWO*} | If untunable Issue 1 and issue 2 boards change ICH. |
| | Screen too yellow. | Change ICH. |

| AREA | SYMPTOM | ACTION |
|---|-------------------------------------|---|
| Colour faults
(cont'd) | Intermittent colour. | 1. Change TC2 (Issue 1 and Issue 2 boards).
2. Change IC14. |
| | Red, Blue or Green 'Sinclair' logo. | Change IC1. |
| | Washed-out colours. | Check TR2. |
| Keyboard faults. | KB1 fault. | 1. Check for short on 2 or more of the 5 tracks.
2. Change membrane. |
| | KB2 fault. | 1. Check for short on 2 or more of the 8 tracks.
2. Change membrane. |
| | Dead keyboard. | Change IC1. |
| | Wrong keyboard response. | Change IC1. |
| | Keyboard response too fast. | Change IC1. |
| Regulator coil. | Coil excessively noisy. | Change coil. |
| Speaker.

NOTE: Figure 4.2 shows typical waveforms in the speaker circuit | No speaker output. | 1. Check load input waveforms.
2. Check TR7.
3. Check D9.
4. Change speaker. |
| Test program. | 'Tape Loading Error' output. | Reload program. |
| | Paper area edges distort. | Change IC1. |

| AREA | SYMPTOM | ACTION |
|---------------------------|-------------------------------------|---|
| Test Program.
(cont'd) | Paper area corrupts during tests. | <ol style="list-style-type: none"> 1. Change IC1. 2. Carry out fault-finding procedure (paragraph 2.2). |
| | Border colours are striped. | Change IC14. |
| | Failure messages. | Carry out fault-finding procedure (paragraph 2.2). |
| | 'Test Passed1 message not flashing. | Change IC1- |
| | Reduced memory size. | <ol style="list-style-type: none"> 1. Perform memory test, 2. Change IC1. |
| Program Loading. | Keyboard does not allow loading. | See keyboard faults, |
| | Program fails to load, | <ol style="list-style-type: none"> 1. Check jack sockets are fully inserted. 2. If loading stripes in border are unusually wide, check D13. 3. Check/change IC1. |
| | 'Program appears. | Check/Change IC2. |

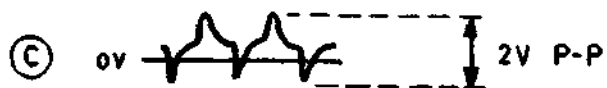
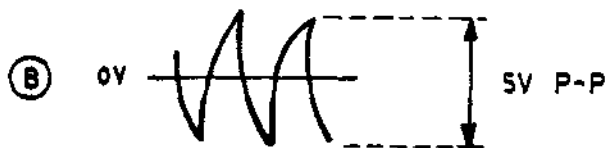
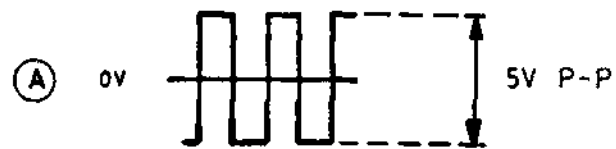
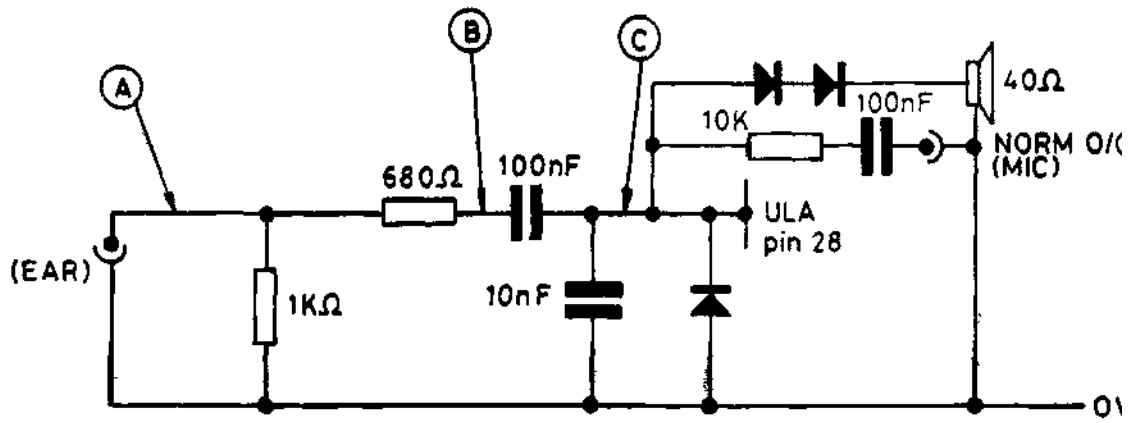
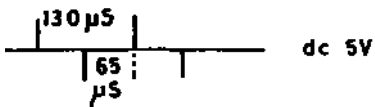
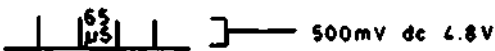
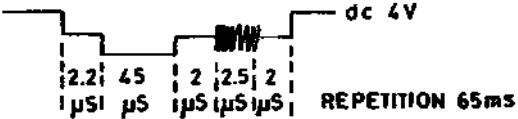

FIGURE 4.2 SPEAKER LOAD INPUT WAVEFORMS

TABLE 4.1. IC14 (IML889) PIN SIGNALS

| Pin No. | Signal |
|----------------------|---|
| 1 | (CHROMA LEAD) SINEWAVE 800mV, 0.2µS, d.c. 9.5V |
| 2 | (R - Y INPUT)  dc 5V |
| 3 | (CHROMA BIAS) d.c. 4.8V |
| 4 | (B - Y INPUT)  500mV dc 4.8V |
| 5 | 0V (GROUND) |
| 12 | (VIDEO INPUT) d.c. 12V unreg. |
| 13 | (CHROMA SUBCARRIER)  dc 4V
REPETITION 65ms |
| 14 | (R.F SUPPLY) |
| 15 | (SOUND TANK) 'LINKED1 12V d>c- |
| 16 | (CHROMA SUPPLY) |
| 17 | (CHROMA OSCILLATOR OUTPUT) SQUAREWAVE 0.2 us 4V P-P.
D.C. 0.8V |
| 18 | (CHROMA LAG) SINEWAVE 800mV P-P 2 us d.c. 9.5V |
| 6,7,8
9,10,
11 | Not Connected |

- NOTES:
- (1) Rails and signals taken on switch-on, computer displaying 'Sinclair1 y
 - (2) No keys pressed
 - (3) All d.c. levels positive wrt 0V

3. REPAIR

3.1 Renewal of components should be carried out using recognised desoldering/heatsinking techniques to prevent damage to the component or to the printed circuit board. Other points to be noted are:

- (a) When replacing a keyboard matrix, take care that the ribbon connectors are fully inserted into the board connectors, and are not kinked during insertion.
- (b) Make sure there is a good contact made between the voltage regulator body and the associated heatsink in order to ensure adequate heat conduction. The heatsink hole in certain Issue 3 boards allows excessive play which could cause fouling of the edge connector. Take care in re-assembly that the heatsink is fitted away from the edge connector.
- (c) When the regulator is being replaced it is recommended that a suitable proprietary thermal grease is applied to the rear surface of the component body.
- (d) The modulator should be replaced as a complete unit.
- (e) When replacing plug-in ICs it is advisable to use the correct removal and insertion tools. Avoid contaminating the connection pins by handling.
- (f) When handling ICs take normal anti-static precautions. It is recommended that only a suitably earthed, low power soldering iron be used.
- (g) After any component has been renewed the circuit board should be examined carefully, to ensure that there are no solder 'splatters' which may cause short circuits between tracks or connector pins.

4. 16k TO 48k UPGRADE

4.1 Integrated Circuits/Link Settings

For both the Issue 2 and the Issue 3 boards the memory upgrade is accomplished by plugging four logic ICs and eight memory ICs into existing board sockets. Depending on the types of memory IC used, appropriate circuit links must be fitted on the board. Figure 4.3 shows the layout of the area of the board containing the empty sockets. The Issue 3 board is shown which also gives positions (top left of diagram) of the links.

4.2 Issue 2 Board

The ICs used on this board are as follows:

| IC | TYPE |
|-------------|---|
| IC15 - IC22 | TI 4532-3 or TI 4532-4 200ns (or 250ns) |
| IC23 | 74LS32 |
| IC24 | 74LS00 |
| IC25, IC26 | 74LS157 (NOT National Semiconductors) |

- NOTES:
- (1) All external RAM ICs must be of the same type (i.e. all -3 or -4 variants).
 - (2) LINK 3 on the board (IC26, pin 10) should be fitted if IC15-IC22 are type 4532-3.
 - (3) LINK 4 should be fitted if IC15-IC22 are type 4532-4.

4.3 Issue 3 Board

The ICs used on this board are as follows:

| IC | TYPE |
|-------------|--|
| IC15 - IC22 | TI 4532-3, TI 4532-4 or OKI
MSM3732 200 ns (or 250ns) |
| IC23 | 74LS32 |
| IC24 | 74LS00 |
| IC25, IC26 | 74LS157 (NOT National Semiconductors) |

- NOTES:
- (1) All extension RAM ICs must be of the same type.
 - (2) Two links must be fitted on the board (grid located between edge connector and m/c jack socket) depending on memory manufacturer and type (high or low enable). See Figure 4.4 for link positions vs manufacturer and IC type.

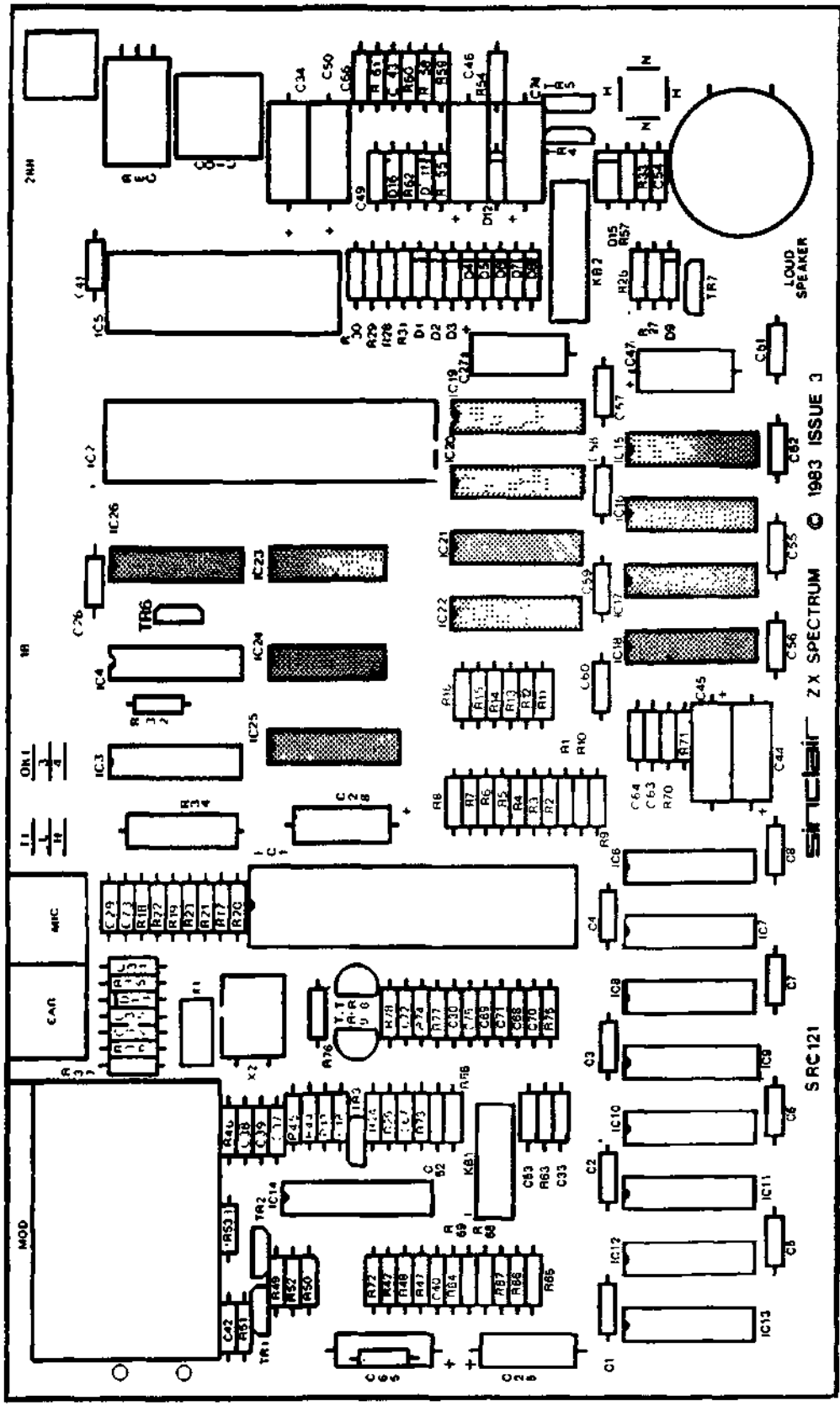
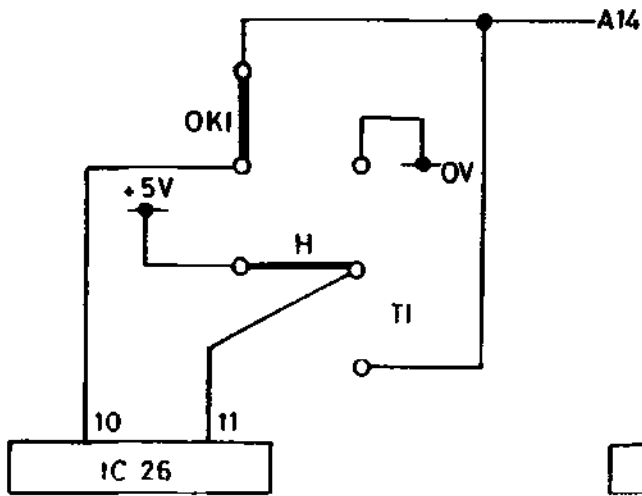
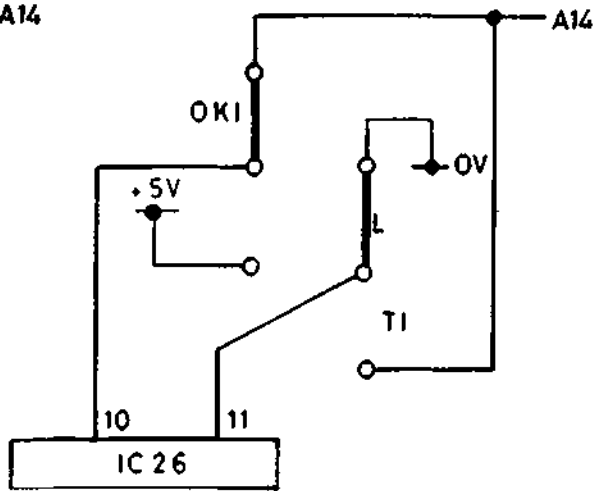

FIGURE 4.3 EXPANSION MEMORY IC LOCATIONS



OKI HIGH ENABLE



OKI LOW ENABLE

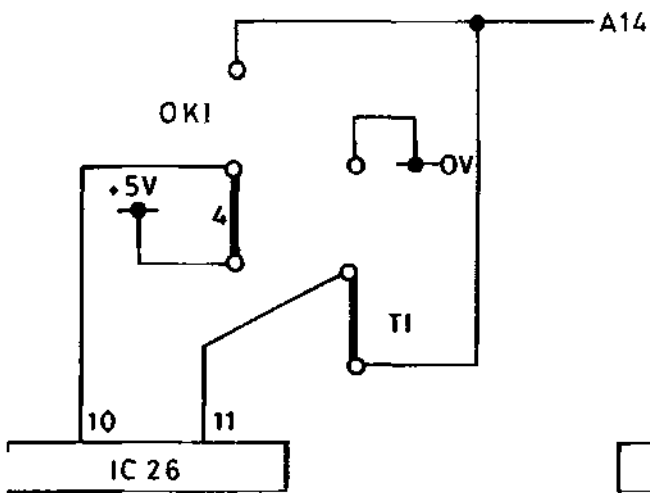

TI 4532-4

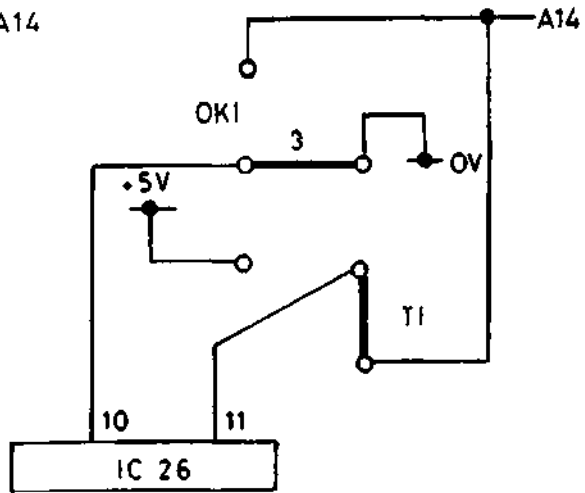

TI 4532-3

FIGURE 4.4 ISSUE 3 LINKS vs IC MANUFACTURER AND TYPE

| | | | | | | | |
|------|--|----------|----|------------------------------------|----|---|--|
| 1C | 11, 12, 13, 14 | 6, 9, 10 | 15 | 20, 21, 22, 23, 24, 25, 26, 27, 28 | 29 | 5 | |
| B | 41, 42, 43, 44, 45, 46, 47, 48, 49, 50, 51, 52, 53, 54, 55, 56, 57, 58, 59, 60, 61, 62, 63, 64, 65, 66, 67, 68, 69, 70, 71, 72, 73, 74, 75, 76, 77, 78, 79, 80, 81, 82, 83, 84, 85, 86, 87, 88, 89, 90, 91, 92, 93, 94, 95, 96, 97, 98, 99, 100, 101, 102, 103, 104, 105, 106, 107, 108, 109, 110, 111, 112, 113, 114, 115, 116, 117, 118, 119, 120, 121, 122, 123, 124, 125, 126, 127, 128, 129, 130, 131, 132, 133, 134, 135, 136, 137, 138, 139, 140, 141, 142, 143, 144, 145, 146, 147, 148, 149, 150, 151, 152, 153, 154, 155, 156, 157, 158, 159, 160, 161, 162, 163, 164, 165, 166, 167, 168, 169, 170, 171, 172, 173, 174, 175, 176, 177, 178, 179, 180, 181, 182, 183, 184, 185, 186, 187, 188, 189, 190, 191, 192, 193, 194, 195, 196, 197, 198, 199, 200, 201, 202, 203, 204, 205, 206, 207, 208, 209, 210, 211, 212, 213, 214, 215, 216, 217, 218, 219, 220, 221, 222, 223, 224, 225, 226, 227, 228, 229, 230, 231, 232, 233, 234, 235, 236, 237, 238, 239, 240, 241, 242, 243, 244, 245, 246, 247, 248, 249, 250, 251, 252, 253, 254, 255, 256, 257, 258, 259, 260, 261, 262, 263, 264, 265, 266, 267, 268, 269, 270, 271, 272, 273, 274, 275, 276, 277, 278, 279, 280, 281, 282, 283, 284, 285, 286, 287, 288, 289, 290, 291, 292, 293, 294, 295, 296, 297, 298, 299, 300, 301, 302, 303, 304, 305, 306, 307, 308, 309, 310, 311, 312, 313, 314, 315, 316, 317, 318, 319, 320, 321, 322, 323, 324, 325, 326, 327, 328, 329, 330, 331, 332, 333, 334, 335, 336, 337, 338, 339, 340, 341, 342, 343, 344, 345, 346, 347, 348, 349, 350, 351, 352, 353, 354, 355, 356, 357, 358, 359, 360, 361, 362, 363, 364, 365, 366, 367, 368, 369, 370, 371, 372, 373, 374, 375, 376, 377, 378, 379, 380, 381, 382, 383, 384, 385, 386, 387, 388, 389, 390, 391, 392, 393, 394, 395, 396, 397, 398, 399, 400, 401, 402, 403, 404, 405, 406, 407, 408, 409, 410, 411, 412, 413, 414, 415, 416, 417, 418, 419, 420, 421, 422, 423, 424, 425, 426, 427, 428, 429, 430, 431, 432, 433, 434, 435, 436, 437, 438, 439, 440, 441, 442, 443, 444, 445, 446, 447, 448, 449, 450, 451, 452, 453, 454, 455, 456, 457, 458, 459, 460, 461, 462, 463, 464, 465, 466, 467, 468, 469, 470, 471, 472, 473, 474, 475, 476, 477, 478, 479, 480, 481, 482, 483, 484, 485, 486, 487, 488, 489, 490, 491, 492, 493, 494, 495, 496, 497, 498, 499, 500, 501, 502, 503, 504, 505, 506, 507, 508, 509, 510, 511, 512, 513, 514, 515, 516, 517, 518, 519, 520, 521, 522, 523, 524, 525, 526, 527, 528, 529, 530, 531, 532, 533, 534, 535, 536, 537, 538, 539, 540, 541, 542, 543, 544, 545, 546, 547, 548, 549, 550, 551, 552, 553, 554, 555, 556, 557, 558, 559, 560, 561, 562, 563, 564, 565, 566, 567, 568, 569, 570, 571, 572, 573, 574, 575, 576, 577, 578, 579, 580, 581, 582, 583, 584, 585, 586, 587, 588, 589, 590, 591, 592, 593, 594, 595, 596, 597, 598, 599, 600, 601, 602, 603, 604, 605, 606, 607, 608, 609, 610, 611, 612, 613, 614, 615, 616, 617, 618, 619, 620, 621, 622, 623, 624, 625, 626, 627, 628, 629, 630, 631, 632, 633, 634, 635, 636, 637, 638, 639, 640, 641, 642, 643, 644, 645, 646, 647, 648, 649, 650, 651, 652, 653, 654, 655, 656, 657, 658, 659, 660, 661, 662, 663, 664, 665, 666, 667, 668, 669, 670, 671, 672, 673, 674, 675, 676, 677, 678, 679, 680, 681, 682, 683, 684, 685, 686, 687, 688, 689, 690, 691, 692, 693, 694, 695, 696, 697, 698, 699, 700, 701, 702, 703, 704, 705, 706, 707, 708, 709, 710, 711, 712, 713, 714, 715, 716, 717, 718, 719, 720, 721, 722, 723, 724, 725, 726, 727, 728, 729, 730, 731, 732, 733, 734, 735, 736, 737, 738, 739, 740, 741, 742, 743, 744, 745, 746, 747, 748, 749, 750, 751, 752, 753, 754, 755, 756, 757, 758, 759, 760, 761, 762, 763, 764, 765, 766, 767, 768, 769, 770, 771, 772, 773, 774, 775, 776, 777, 778, 779, 780, 781, 782, 783, 784, 785, 786, 787, 788, 789, 790, 791, 792, 793, 794, 795, 796, 797, 798, 799, 800, 801, 802, 803, 804, 805, 806, 807, 808, 809, 810, 811, 812, 813, 814, 815, 816, 817, 818, 819, 820, 821, 822, 823, 824, 825, 826, 827, 828, 829, 830, 831, 832, 833, 834, 835, 836, 837, 838, 839, 840, 841, 842, 843, 844, 845, 846, 847, 848, 849, 850, 851, 852, 853, 854, 855, 856, 857, 858, 859, 860, 861, 862, 863, 864, 865, 866, 867, 868, 869, 870, 871, 872, 873, 874, 875, 876, 877, 878, 879, 880, 881, 882, 883, 884, 885, 886, 887, 888, 889, 890, 891, 892, 893, 894, 895, 896, 897, 898, 899, 900, 901, 902, 903, 904, 905, 906, 907, 908, 909, 910, 911, 912, 913, 914, 915, 916, 917, 918, 919, 920, 921, 922, 923, 924, 925, 926, 927, 928, 929, 930, 931, 932, 933, 934, 935, 936, 937, 938, 939, 940, 941, 942, 943, 944, 945, 946, 947, 948, 949, 950, 951, 952, 953, 954, 955, 956, 957, 958, 959, 960, 961, 962, 963, 964, 965, 966, 967, 968, 969, 970, 971, 972, 973, 974, 975, 976, 977, 978, 979, 980, 981, 982, 983, 984, 985, 986, 987, 988, 989, 990, 991, 992, 993, 994, 995, 996, 997, 998, 999, 1000 | | | | | | |
| C | | | | | | | |
| D | | | | | | | |
| RE | | | | | | | |
| MISC | | | | | | | |

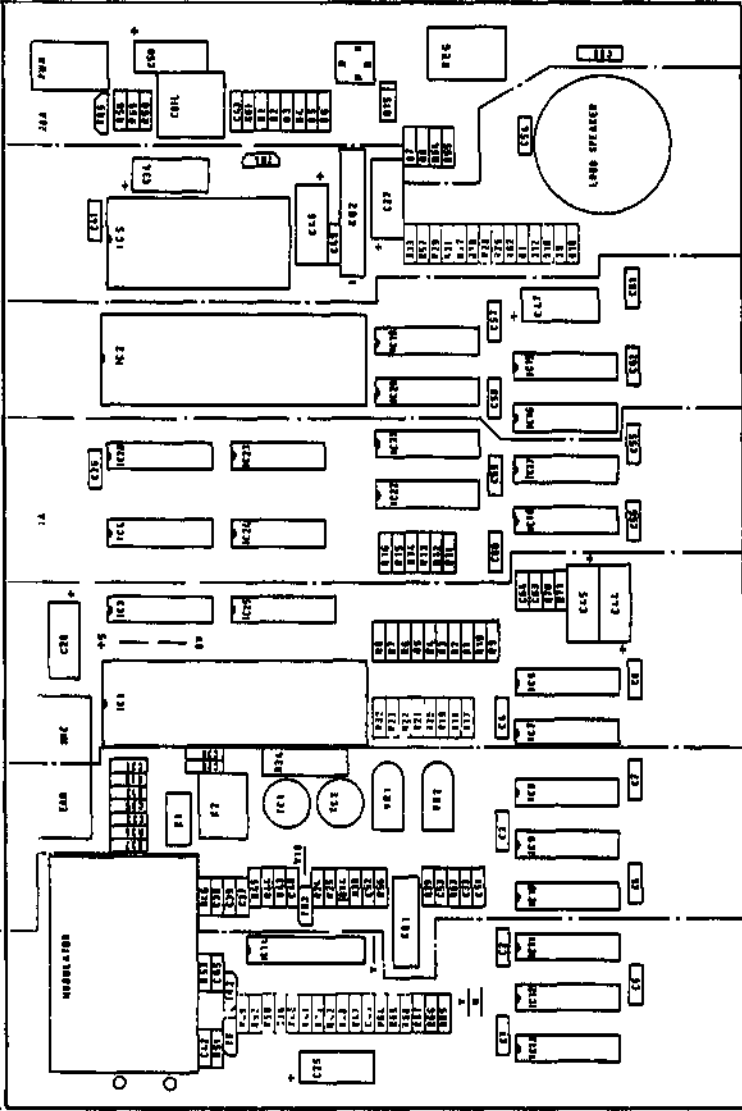

NOTES:
 (1) DO NOT USE 1 BOARD LONG THE LONG BOARD INSTEAD IS USED AS AN INDICATOR OF POSITION. THE BOARD IS NOT TO BE USED AS AN INDICATOR OF POSITION IN THE BOARD CASE.
 (2) AFTER THE COMPLETE ASSEMBLY HAS BEEN MADE AND THE UNIT IS OPERATING, THE BOARD SHOULD BE KEPT IN THE BOARD CASE.

PRINTED CIRCUIT BOARD (ISSUE 2) FIG 5 1
 COMPONENT LAYOUT C5K12746
 ISSUE B

SECTION 5

PARTS LIST

| Sub-Section | LIST OF CONTENTS | Page No. |
|-------------|--------------------|----------|
| 1 | Introduction | 5.1 |
| 2 | Notes to Table 5.2 | 5.1 |

1. INTRODUCTION

1.1 Parts lists for the ZX SPECTRUM are provided in table form; one for the case assembly (Table 5.1) and another for the board assembly (Table 5.2). The latter covers the Issue 2 and 3 Spectrums and is related to the board layout diagrams given in Figure 5.1 and 5.2. Table 5.2 also lists the alternative components which the service engineer will occasionally find on production versions of the Issue 2 board or may introduce retrospectively in order to improve performance. These components are listed in the column headed 'ISSUE 2 MODS' with references to notes against them. These notes are explained below-

2. NOTES TO TABLE 5.2

- (1) The alternative values given for R47, R49, R56 and T63 are used if the ULA fitted is Type 6C001.
- (2) The alternative values for R48, R50, R72 and C65 are introduced to improve the colour quality.
- (3) C74 is essential on all Issue 2 boards and should be fitted retrospectively. At the same time R60 must be replaced with the larger value.
- (4) The introduction of alternative components for R24 and R27 is essential. At the same time C67 replaces D14 and R73 is added.
- (5) Issue 2 boards fitted with the Type 5C112 ULA have either a transistor (TR6) or diode/resistor modification (see Issue 2 circuit diagram for details).
- (6) On Issue 3 boards only crystal X2 must have a close tolerance specification (i.e. 10 ppm absolute, 10 ppm 20°C to 60°C, 5 ppm per year.)
- (7) On Issue 3B boards, the d.c. converter design has improved reliability. R60 is changed from 270n to 68ft and C49 is changed from 47nF to 560pF. Capacitor C77 (100nF) has been added.

2.1 General Capacitor Change. Early Issue 2 units were manufactured using a considerable number of 47 nF and 100 nF disc capacitors. Where these occur the service engineer should take the opportunity to replace C41 and C49 with axial types.

TABLE 5.1 CASE ASSEMBLY

| DESCRIPTION | MANUFACTURER |
|---|---------------|
| Assembled board as appropriate
(Table 5.2) | |
| Moulded Upper Case | |
| Moulded Lower Case | |
| Keyboard Mat (Rubber) | |
| Keyboard Membrane | N.F.I. |
| Keyboard Template | |
| Rubber Feet | |
| Self Tap Screws (case fixings), 5 off | |
| Double-sided adhesive tape -
12 mm wide; Tesafix 959 | B.D.F. Tesa |
| Double sided adhesive tape -
6 mm wide; Tesafix 959 | B.D.F. Tesa |
| Self Tap Screw (board fixing), 1 off | |

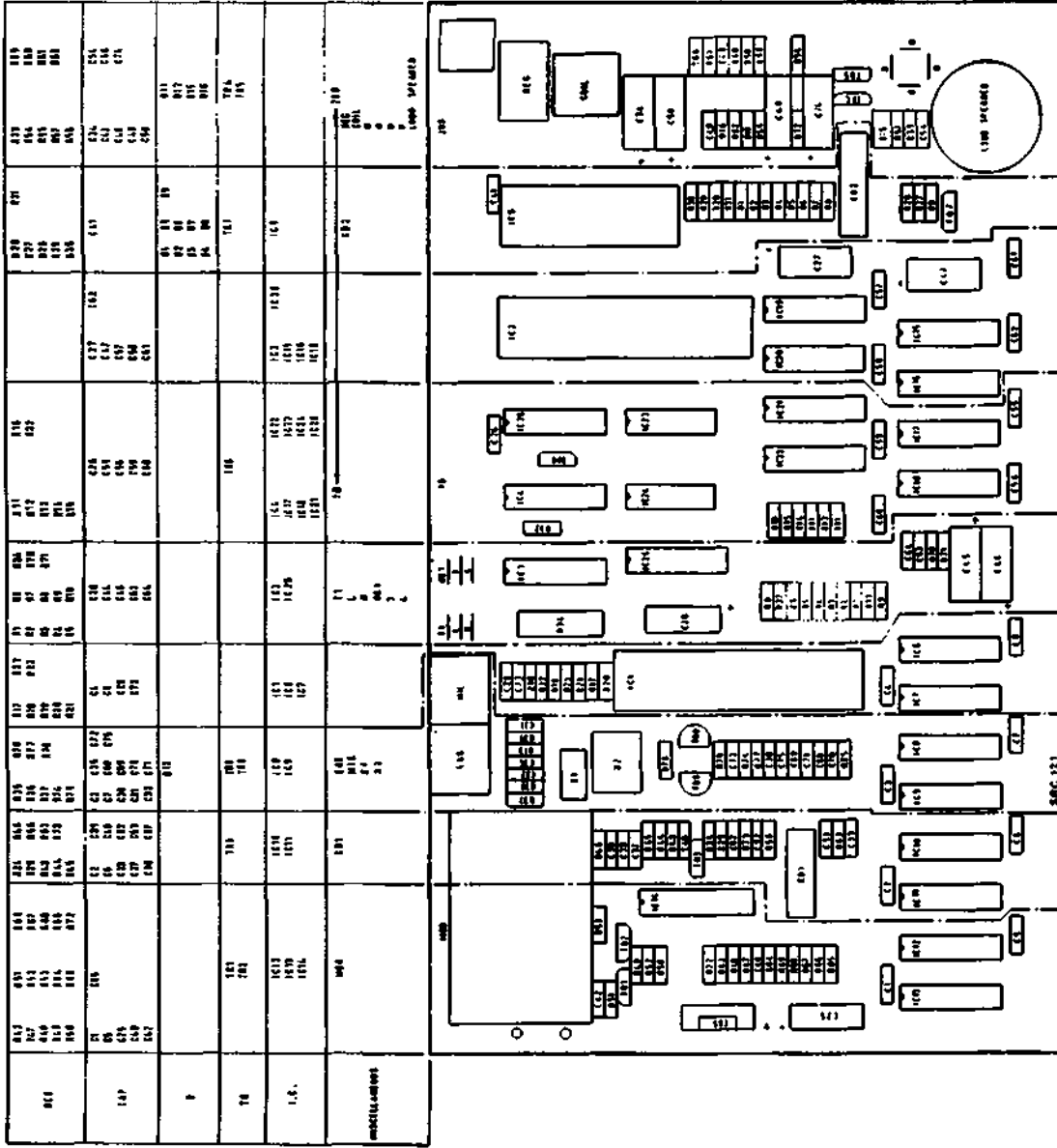

PRINTED CIRCUIT BOARD (ISSUE 3) FIG. 5.2
 COMPONENT LAYOUT DSK 12756
 ISSUE A

TABLE 5.2 BOARD ASSEMBLY

| Circuit Reference | Issue 2 | Issue 2 Mod | Notes | Issue 3 | Rating/
Tol | Manufacture Type |
|--|---------|-------------|-------|----------|----------------|------------------|
| CAPACITORS
(Unless otherwise stated all capacitors are axial types) | | | | | | |
| C1-C8 | 47 nF | | | 47 nF | 25V, 10% | Ceramic |
| C25 | 22 yF | | | 22 yF | 10V,-10%+80% | Elect. |
| C26 | 47 nF | | | 47 nF | 25V, 10% | Ceramic |
| C27 | 1 yF | | | 1 yF | 50V,-10% | Ceramic |
| C28 | 22 yF | | | 22 yF | 10V,-10%+80% | Elect. |
| C29/C30 | 47 nF | | | 47 nF | 25V, 10% | Ceramic |
| C31/C32 | 100nF | | | 100nF | 25V, 10% | Ceramic |
| C33 | 47 nF | | | 47 nF | 25V, 10% | Ceramic |
| C34 | 22 yF | | | 22 yF | 10V,-10%+80% | Elect. |
| C35 | 10 nF | | | 10 nF | 25V, 10% | Ceramic |
| C36 | 47 nF | | | - | 25V, 10% | Ceramic |
| C37/C38 | 33 pF | | | 33 pF | 25V, 10% | Ceramic |
| C39 | 10 nF | | | 10 nF | 25V, 10% | Ceramic |
| C40/C42 | 47 nF | | | 47 nF | 25V, 10% | Ceramic |
| C43 | 100nF | | | 100nF | 25V, 10% | Ceramic |
| C44/C45 | 100yF | | | 100yF | 16V,10%+80% | Ceramic |
| C46 | 1 yF | | | 1 yF | 50V,-10%+80% | Elect. |
| C47 | 22 yF | | | 22 yF | 10V,-10%+80% | Elect. |
| C48 | 47 nF | | | 47 nF | 25V, 10% | Ceramic |
| C49 | 47 nF | | (7) | 47/560pF | 25V, 10% | Ceramic |
| C50 | 22 yF | | | 22 yF | 10V,-10%+80% | Elect. |
| C51 | | | | | | |
| C52/C53 | 150pF | | | 150pF | 25V, 10% | Ceramic |
| C54 | 470pF | | | - | 25V, 10% | Ceramic |
| C55-C62 | 47 nF | | | 47 nF | 25V, 10% | Ceramic |
| C63 | 47 pF | | | 47 pF | 25V, 10% | Ceramic |
| C64 | 100pF | | | 100pF | 25V, 10% | Ceramic |
| C65 | 100yF | 22 yF | (2) | 22 yF | 20V,10%+80% | Elect. |
| C66 | 47 nF | | | 47 nF | 25V, 10% | Ceramic |
| C67 | - | 100pF | (4) | 100pF | 25V, 10% | Ceramic |
| C68-C71 | - | - | | 100nF | 25V, 10% | Ceramic |
| C72/C73 | - | | | 16 pF | 25V, 10% | Ceramic |
| C74 | - | 4.7WF | (3) | 4.7uF | 5V min | Elect. |
| C75 | - | - | | 100nF | 25V, 10% | Ceramic |
| TC1/TC2 | | | | | | |
| C76 | - | | | 47 nF | 25V, 10% | Ceramic |
| C77 | - | - | (7) | 100nF | 25V, 10% | Ceramic |

COIL

| Circuit Reference | Issue 2 | Issue 2 Mod | Notes | Issue 3 | Rating/
Tol | Manufacture Type |
|-------------------|----------|-------------|-------|----------|----------------|------------------|
| Coil | SPECTRUM | - | - | SPECTRUM | - | 1703 |

CONNECTORS

| Reference | Description | Manufacturer/
Part Number |
|-----------|------------------------|------------------------------|
| EAR | 3.5 mm jack socket | |
| MIC | 3.5 mm jack socket | |
| PWR | 2.1 mm co-axial socket | |
| KB1 | 5-way ribbon connector | Molex 5229-05CPB |
| KB2 | 8-way ribbon connector | Molex 5229-08CPB |

CRYSTALS

| Circuit Reference | Issue 2 | Issue 2 Mod | Notes | Issue 3 | Manufacture Type |
|-------------------|--------------|-------------|-------|--------------|------------------|
| X1 | 14.000000MHz | - | Note | 14.000000MHz | |
| X2 | 4.433619MHz | - | (6) | 4.433619MHz | |

DIODES

| Circuit Reference | Issue 2 | Issue 2 Mod | Notes | Issue 3 | Manufacture Type |
|-------------------|---------|-------------|-------|---------|------------------|
| D1-D9 | 1N4148 | - | - | 1N4148 | Signal |
| D10 | 1N4148 | - | - | - | Signal |
| D11-D13 | 1N4148 | - | - | 1N4148 | Signal |
| D14 | 1N4148 | - | (4) | - | Signal |
| D15 | BA157 | - | - | BA157 | Rectifier |
| D16 | 5V1 | - | - | 5V1 | Zener |

INTEGRATED CIRCUITS

| Circuit Reference | Issue 2 | Issue 2 Mod | Notes | Issue 3 | Manufacture Type |
|-------------------|-----------|-------------|-------|----------------|-----------------------|
| IC1(ULA) | 5C102 | 5C112 | (1) | 6C0001 | - Ferranti |
| IC2(CPU) | Z80A/U780 | - | | Z80A/M780 | |
| IC3/IC4 | 74LS157N | - | | 74LS157N | - Not National |
| IC5(ROM) | SPECTRUM | SPECTRUM | | SPECTRUM | - NEC/Hitachi |
| IC6-IC13 | 4116 | - | | 4116 | - 150 ns |
| IC14 | LM1889 | - | | LM1889 | |
| IC15-IC22 | TI4532 | - | | TI4532/MSM3732 | 48k only Texas/OKI |
| IC23 | 74LS32N | - | | 74LS32N | 48k only |
| IC24 | 74LSOON | - | | 74LSOON | 48k only |
| IC25/IC26 | 74LS157N | - | | 74LS157N | 48k only Not National |

RESISTORS (1/4W, 5% unless otherwise stated)

| Circuit Reference | Issue 2 | Issue 2 Mod | Notes | Issue 3 | Rating Tol | Issue 3B |
|-------------------|-------------|-------------|----------|---------|------------|----------|
| R1-R8 | 470R | | | 470R | | |
| R9-R16 | 8K2 | | | 8K2 | | |
| R17-R23 | 330R | | | 330R | | |
| R24 | 3K3 | 1K0 | (4) | 1K0 | | |
| R25 | 180R | | | 180R | | |
| R26/R27 | 680R | | | 470 | | |
| R28 | 10K0 | | | 10K | | |
| R29 | 1K0 | | | 10K | | |
| R30 | 1K0 | | | 10K | | |
| R31 | 220K0 | | | 220K | | |
| R32 | 100R | | | 100R | | |
| R33 | 680R | | | 680R | | |
| R34 | 15R | | | 15R | 1/2 or 1W | |
| R35 | 10K0 | | | 10K | | |
| R36 | 680R | | | 680R | | |
| R37 | 1K0 | | | 1K | | |
| R38 | 3K3 | | | | | |
| R39 | 3K3 | | | | | |
| R40 | 1K0 | | | | | |
| R41 | 1K0 | | | | | |
| R42 | 1K0 | | | 1K0 | | |
| R43 | 3K0 | | | 3K0 | 2% | |
| R44 | 5K1 | | | BK1 | 2% | |
| R4B/R46 | 1K0 | | | 1K0 | | |
| R47 | 220R | 1K0 | (1) | 1K0 | | |
| R48 | 4K7 | 2K2 | (2) | 2K2 | | |
| R49 | 8K2 | 10K0 | (1) | 10K0 | | |
| RBO | 8K2 | 4K7 | (2) | 4K7 | | |
| R61/R52 | 2K2 | | | 2K2 | | |
| R53 | 390R | | | 390 | | |
| R54 | 100K | | | 100K | | |
| R55 | 56R | | | 56R | | |
| R56 | 220R | 470R | (1) | 1K0 | | |
| R57 | 330R | | | | | |
| R58 | 1K0 | | | 1K0 | 2% | |
| R59 | 1K8 | | | 1K8 | 2% | |
| R60 | 100R | 270R | (3), (7) | 270R | | 68R |
| R61/R62 | 15R | | | 15R | | |
| R63 | 220R | 470R | (1) | 1K0 | | |
| R64 | 15R | | | 15R | | |
| R65-R69 | 10K0 | | | 10K0 | | |
| R70/R71 | 220R | | | 220R | | |
| R72 | 470K or 18K | 10K0 | (2) | 10K0 | | |
| R73 | - | 1K0 | (4) | 1K0 | | |
| R74/R75 | - | | | 10K0 | | |
| R76/R77 | - | | | 1K0 | | |
| R78 | - | | | 470R | | |
| VR1/VR2 | 2K2 | | | | | |

TRANSISTORS

| Circuit Reference | Issue 2 | Issue 2 Mod | Notes | Issue 3 |
|-------------------|---------------|-------------|-------|---------|
| TR1/TR2 | ZTX313 | - | | ZTX313 |
| TR3 | ZTX313 | - | | ZTX313 |
| TR4 | ZTX650/TIPP31 | - | | ZTX650 |
| TR5 | ZTX213 | - | | ZTX213 |
| TR6 | ZTX313 | - | (5) | ZTX313 |
| TR7 | - | - | | ZTX450 |
| TR8/TR9 | - | - | | BC184 |

MISCELLANEOUS

| Reference | Description | Manufacturer/
Part Number |
|-------------------------------|---|------------------------------|
| REG | 5V regulator | 7805 |
| MOD | UHF Modulator with E36
vision carrier (UK only) | Astec
UM1233 |
| Loudspeaker | 40 ohm T.V. Type | |
| Modulator Screen
Insulator | | 1740 |
| Heatsink | Special (Issue 2 or 3) | |
| Regulator Fixings(1) | Screw, ch hd. 4BA x 15/16 in | |
| (2) | Washer, shk prf, 4BA | |
| (3) | Nut, hex, 4BA | |
| OIL SKT | 16-way (10-off) for 48k
expansion RAM (16k model only) | |
| OIL SKT | 14-way (2-off) for 48k
expansion RAM (16k model only) | |
| OIL SKT | 28-way for IC1 (ULA) | |

GENERAL DATA

- Earliest version - very pale brown keys.
- Second version - grey keys
- Third/Fourth versions - grey keys, but heatsink now visible through the edge connector slot
- Early Spectrum plus - same as fourth type.
- Disassembly - after removing the screws, tilt back, face up and carefully lift the top taking care not to break any of the keyboard tails.
- Heatsink - when operating computer with the heatsink removed to obtain access a temporary heatsink must be used made of anything as long as it fits under regulator.
- Circuit Diagram - idealised version on centre pages shows all modifications which should be made. Note that connecting items such as standard capacitors may not be shown.
- Edge Connector - 28 pin double-sided to which no interface may be inserted or removed whilst computer is switched on.
- Plugs & Cables - use only genuine Sinclair issue or HK plugs, etc.
- Power Supply - Where any possibility of fluctuating mains exists a transient suppressor should be fitted.
- Links - T1/T3 for Texas THS4532-3; T1/T4 for Texas TMS4532-4
1/H for OKI HSH3732H; 1/L for OKI MSM3732-L.

Other Service/Repair Manuals by T.I.S. Include:-

Rank A823 CTV Chassis

Philips G8 CTV Chassis

Thorn 3000/3500 CTV Chassis

Thorn 8000/8004/8500/8600 CTV Chassis

Rank T20/20A CTV Chassis

The Tunbridge & McCourt T.V. Repair Manuals

The Tunbridge Video Repair Manuals

SERVICE DATA

Modification of earplug: Connect a 330 ohm resistor between signal and earth leads of earplug to allow earplug to be left in place while saving a programme.

Inserting or removing such items as joysticks, especially via a Kempston interface, while the computer is switched on will damage the power resistors and regulator.

Modification to voltage generator circuit: Where not fitted already, insert a 22uf capacitor between the TR4 and D15 as shown in the circuit diagram, this will ensure the correct 12v supply. On early models replace R60 by a 270 ohm resistor and fit C74 if missing. Ensure that the 12v supply is 12v.

Manufacturer's advised modifications: In early versions replace all ceramic capacitors by axial ones and replace C46 by a high-temperature luf type. All resistors to be changed to show the second value show in centre pages circuit diagram herein; same applies to capacitors.

Weak sound: Only if particularly noticeable should the sound section be changed to same as shown herein.

Tape and Sound Circuits: 5Vp-p at ear socket for 2Vp-p at IC1 verifies IC1.

Alignment: Only needed for early models. Place meter on pin 4 of IC4 and adjust VR1 to obtain 130mV; adjust VR2 to obtain -75raV at pin 2 with a 20mV allowable error either way. Use TC2 to set colour subcarrier frequency to 4.433619MHz to 50Hz either way. TCI only helpful to improve screen colour pattern.

Alignment: All models. Run the programme to display the eight colours in sequence from black to white. This is normally given as:-

```
10 FOR A=0 TO 7
20 FOR B=0 TO 3
30 PAPER A: PRINT" ";
40 NEXT B
50 NEXT A
60 GOTO 10
```

If this shows incorrect or missing colours then align as stated for early models. See repair data for later models.

REPAIR DATA

1) GENERAL REPAIR PROCEDURE AND NOTES ON ALL FAULTS

These computers are reportedly very unreliable with some 50% of new ones alleged to have to be returned for replacement. Many faults are due to loose or badly fitted components so that a good checkover is essential for this reason, to determine if a factory failure first.

Check heatsink first for any reported fault, is it loose? Are there overtightened screws? Look for dry joints, cracks in print or cracked boards, badly fitted components, especially ICs; dirty or tarnished contacts, pins, holders, edge connectors; damaged keyboard tails and fins are certainly not uncommon for whatever reason.

Before investigating any fault check any add-ons and interfaces to the computer for broken solder, etc. caused by user wiggling them about. It is also essential to note if add-on is loose or faulty which will give a guide to any damage so caused. This will also determine if fault in add-on not computer. Knowing what add-ons are used can be a good guide to probable fault: for example, suspect TR4 blown and/or destroyed RAMS if a Kempton is used.

Check if customer has been inserting or removing any add-ons without first switching off and point out how this practice has damaged machine and costing him unnecessary expenditure. If this is admitted then check TR4 first then RAMS and see symptom 3.

2) WONT LOAD FROM RECORDER

Almost invariably this will be caused by the alignment of the recorder head not being good enough. The recorder will play music, etc. and function well but it will still need adjusted to operate the Spectrum properly and it matters not whether it is an old or just newly bought recorder.

Disconnect Spectrum from recorder and with any tape playing use a long thin-bladed screwdriver to adjust the azimuth screw through the hole normally provided for this purpose. The object is to obtain the sharpest possible sounding note, noting that if note is in the least muffled sounding then there is no chance of the Spectrum loading from it.

If no hole is provided this should be done with the recorder cover removed. Although it is recommended that volume should be set at midpoint it is far better to vary volume setting to that at which maximum treble is obtained. Finally give head a good clean and recheck setting.

If the adjustment does not cure the problem then save a short programme from the computer (or use one previously saved) and if this doesn't load then it is safe to assume that there is a fault, probably in the computer. In this case, check connections to computer and the circuit from the edge connector to the first I.C.

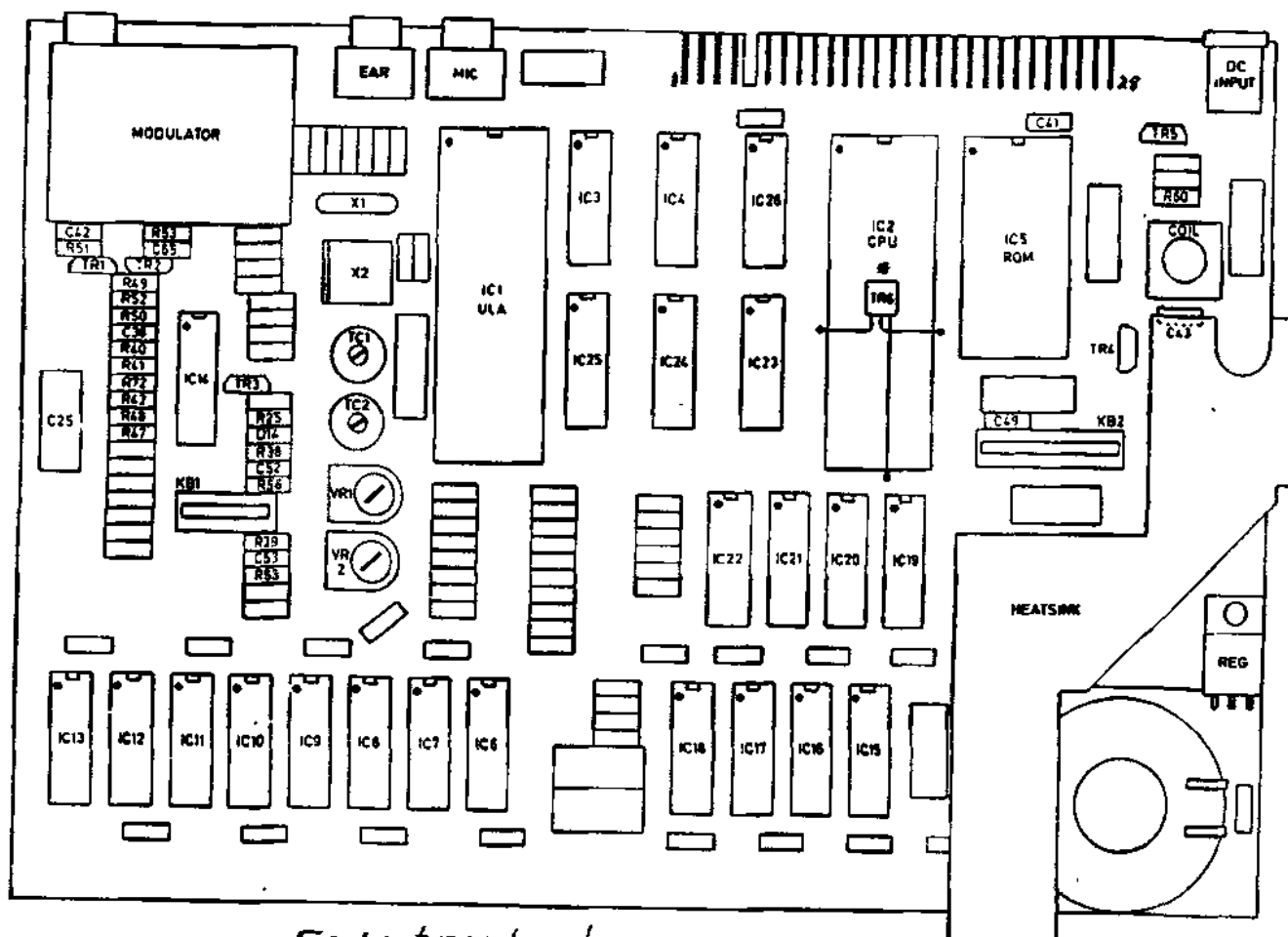

Early types board

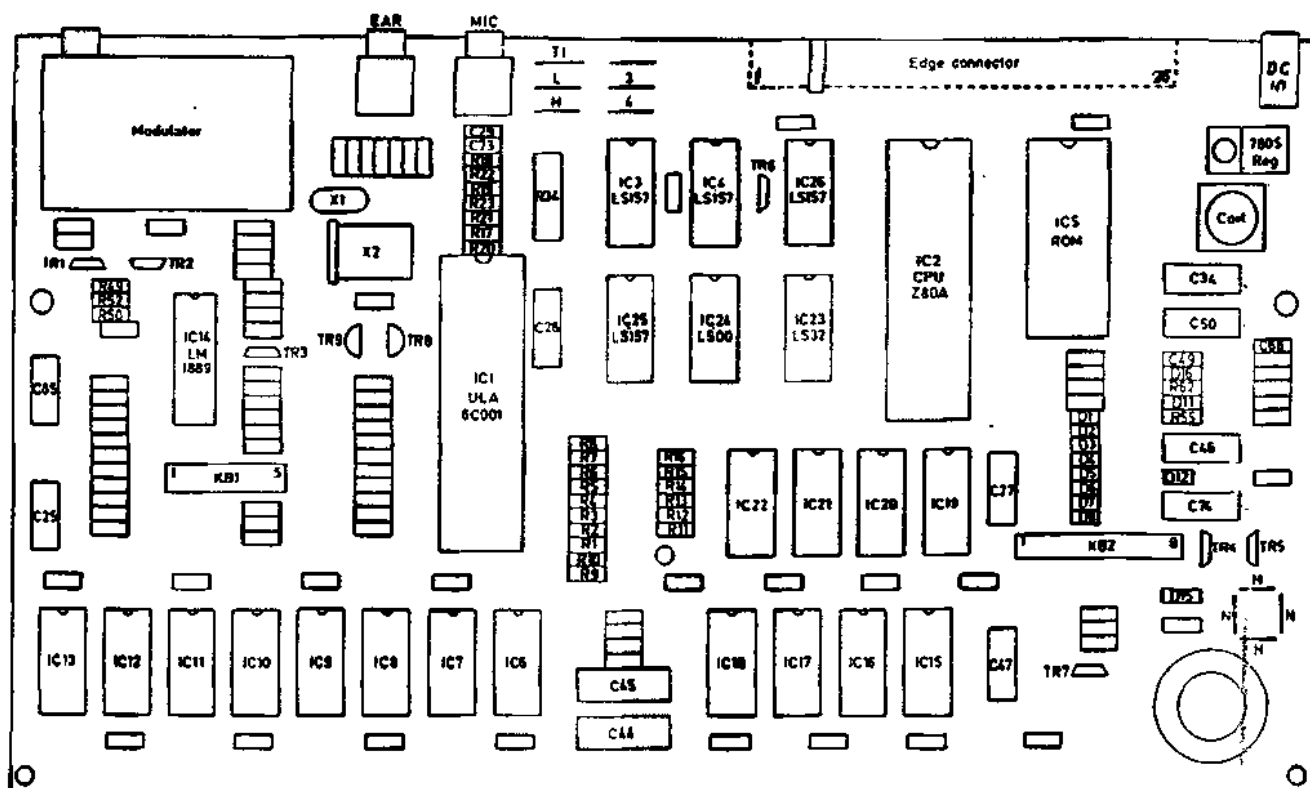

Later types board

Sinclair Spectrum

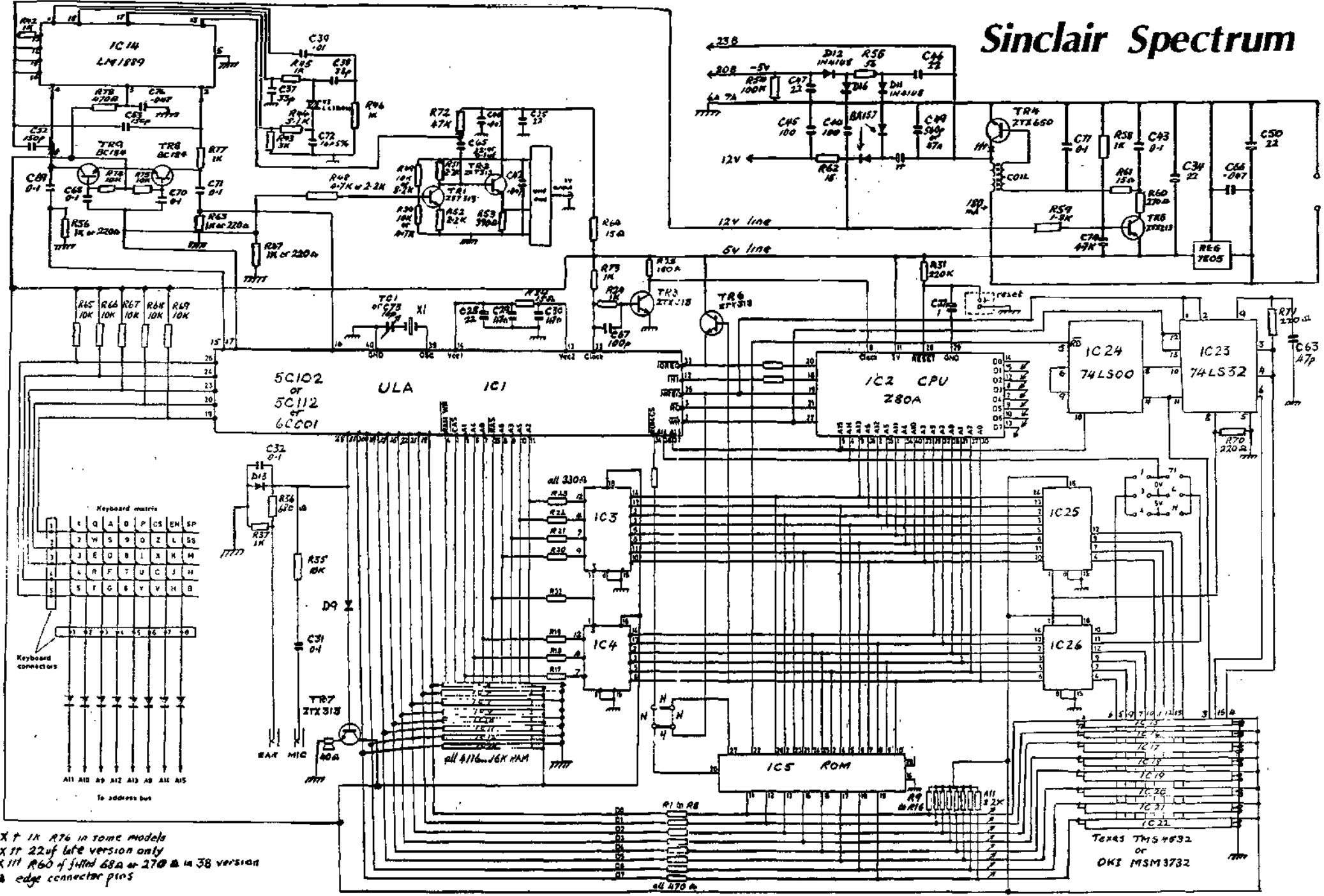

X† 1K R76 in some models
 X†† 22uf life version only
 X††† R60 of fitted 68A or 270 in 3B version
 & edge connector pins

TEXAS TMS4832
 or
 OKI MSM3732

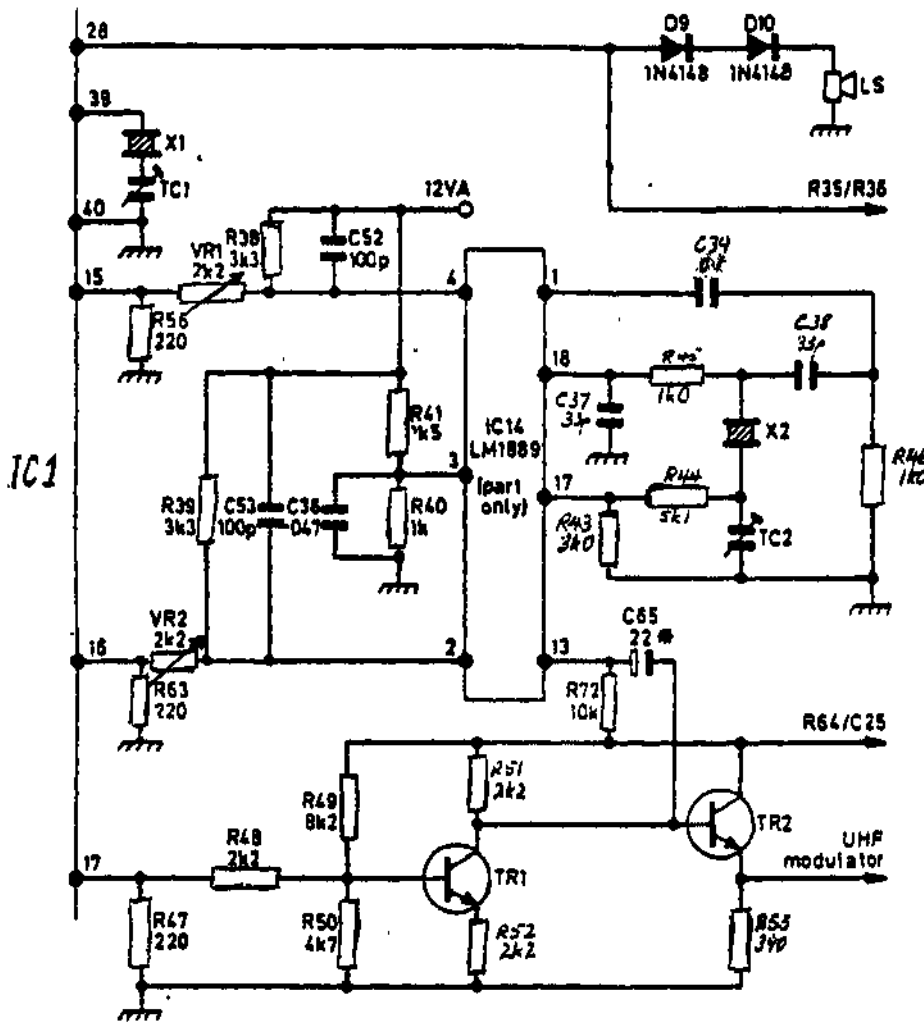

Early circuit showing presets Td, TC2, VR1 and VR2 to match the early type boards.

Note:- the different pins 16/17 setup from Id in the generalised circuit diagram shown in the middle pages.

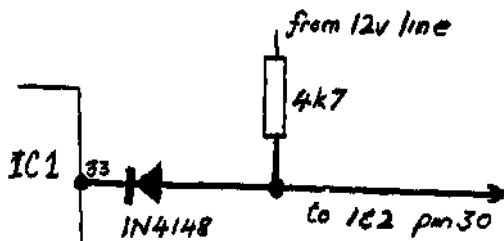

In very versions, instead of TR6 a somewhat **unreliable**, resistor/diode was used which should be modified as shown in the centre pages.

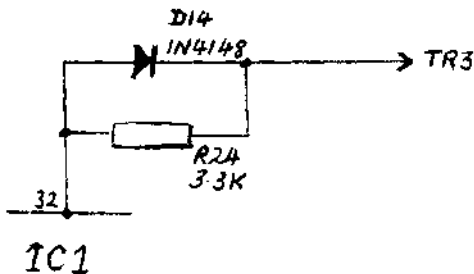

This very **unreliable** circuit was used in very early versions from pin 32 to base of Id. This circuit **should** be modified to that shown in the centre pages if not already done.

3) NO COIL BUZZ FROM INVERTER, -5V ABSENT

From symptom 1 it should be obvious that TR4 (ZIX650) is very prone to damage and this symptom is a sure indication that TR4 must be replaced. However, before replacing the TR4 check the TR5 (ZIX213) (using a transistor tester is O.K.) and the coil since it is not unknown for all three to have gone at the same time and if only the TR4 is replaced it can fail again immediately if the others are faulty.

Whether or not these three are faulty or not, there can be one or more faulty RAMS as well caused possibly by the same forcing in of an interface during switch on. If all else has been fixed, switch on and check if any RAM gets hot; replace any very hot RAMS either in basic set or in extra board as this is a sure sign of being short circuit. If open circuit, the quickest way to check is to by-pass each RAM in turn using a RAM known to be O.K. When so doing the same RAM must be used as the suspect and it should not be removed after each check for some ten seconds after each switch off or it will fault itself. Use of a 'scope or logic probe is clearly a better alternative if available. Tandy m<tke a good, inexpensive logic probe.

4) DIRECT CHECK FOR A SINGLE FAULTY RAM

Type PRINT PEEK 23732+256 * PEEK 23733 (CR). If computer RAMS O.K. the reply is either 32767 or 85535, if less than either this means that there is a shortage of available RAMS, thus one or more RAMS may be faulty.

Call the reply N and if POKE N+1,85 (CR) then PRINT PEEK N+1 (CR) is typed the reply should be 85 if RAMS O.K., in that case type POKE N+1,170 (CR) then PRINT PEEK N+1 (CR) when a different number to the 170 you have just poked into that address will be printed. 85 and 170 are the easiest binary numbers (01010101 and 10101010) to cover all combinations in an 8-bit chip.

Where a different reply is given to either POKE locate the incorrect IC as follows:-

Where 85 is poked in

IC6 faulty gives 84; IC7 87; IC8 81; IC9 93; IC10 69; IC11 117; IC12 21; IC13 213.

Where 170 is poked in

IC15 faulty gives 171; IC16 158; IC17 174; IC18 162; IC19 186; IC20 138; IC21 234; IC22 42.

5) NO COIL BUZZ FROM INVERTER, REG7805 OPEN CIRCUIT

Before replacing the 7805 check the heatsink to see if faulty or badly fitted. Remedy any physical defect in print or damage around screws, etc. Also check the TR4/5 and coil.

6) CONTINUAL FAILURE OF POWER SUPPLY TRANSISTORS

Ensure that all modifications have been carried out and that the edge connector is O.K. and not loose or, damaged. Check for proper fitting of all peripherals and verify that owner is not persistently inserting/removing any of the add-ons, etc. while the computer is switched on. Note that many users are apparently incapable of grasping this simple point. Check the plug/sockets and cable, if not suitable then replace with correct ones. Check the mains and possible interference from other items on same circuit.

If satisfied then check if the 0v is correct on earth. Monitor the 0v while running computer as this may show up an intermittent voltage fault. A systematic check on all capacitors/resistors to earth should find the culprit for this uncommon cause.

7) KEYBOARD FAULTS

It is recommended that keyboards are better replaced completely since they take a lot of battering and replacement is quite inexpensive. If it is decided that the keyboard is worth repairing then the diagram will show which key is faulty according to keys in error.

If the entire keyboard is non-functional then check the 5v supply is reaching it O.K. before replacing the ULA I.C. Probably the commonest fault lies with a faulty 10K resistor (R65 to R69) easily identified according to which keyboard column is faulty.

8) VARIOUS FAULTS WHICH APPEAR ONLY WHEN WARM

Check heatsink thoroughly. If heatsink is O.K. then the ULA I.C. IC1 will be the cause. If IC1 has been replaced before it may be worth adding extra heatsink for it. See also following symptom.

9) INTERMITTENT FAULTS

If such faults show up with a comparatively new Spectrum then it is most likely that they are due to poor contacts/soldering during the manufacturing process. Check all holders and pins for tarnish and dry joints. Replace faulty holders by cutting them out and replacing completely. Check after this for poor contacts or loose contacts, look for items which have been poorly soldered or even where soldering has been omitted. Finally check the boards for hairline cracks and breaks, especially radiating from heatsink screws.

10) TEXAS SN1889 INSTEAD OF LHA889

A few models appeared with the SN version and these may even have been used as replacements during repairs. Although unlikely to find now, if SN types have been used replace completely by LH type.

11) POWER SUPPLY O.K. - COMPUTER NOT WORKING CORRECTLY :

If computer is functioning at all check for single RAM failure then multiple RAM failure as already described. If RAMS are O.K. or fault is more serious and RAMS cannot be checked then check if the 5v supply is reaching all I.C.s in order IC1, 2, 24, 23, 3, 4, 26, 25 and 5. Replace the open circuit component cutting off the 5v supply if this is the case. '

Faulty or missing sound usually identifies the ULA I.C. IC1 as being faulty and this is the most likely suspect in any case. Flick the clock crystal with your finger, this will quickly determine if it is faulty or not.

Although I.C.s are best checked out systematically using a logic probe or even a 'scope, it is worth noting that after IC1 the most likely culprits are IC2 and IC5, neither of which are particularly reliable and it may even be worth replacing the three automatically as a fast check.

12) PERMANENT I.C. CHECKER FOR LOGIC PROBE USE

If a logic probe is available it is well worth making a table of the results of checking each IC pin with a good computer switched on with keyboard disconnected. Thus when any computer is being tested all that is needed is to compare the readings with your correct set and the different readings will quickly pinpoint the faults.

13) FLICKERING WHITE BACKGROUND - MAY BE CAUSING EYESTRAIN

If resetting the computer doesn't help, which is not uncommon if a CTV is being used, then the only thing is to set up the computer to display a coloured background with white printing. See spectrum manual for this, but green is the most relaxing background. Save this programme and load it every time Spectrum is not being used for games.

14) SPARE PARTS SUPPLIERS

At time of printing the most popular suppliers appear to be:-
CPC Electronic Components, 194 North Road, Preston, Lanes.
PV Tubes, 104 Abbey Street, Accrington, Lanes. BBS 1EE.

This list may be amended in future printings.

NOTES