

- 25 Watt Loudspeaker
- 70V or 100V Line Transformer with 25W, 12.5W, 6W and 2W tapings
- 8 ohm or 16 ohm
- Type UL 4/4X/13
- Operating Temperature Range -20°C to +55°C



Unit Type No. E2xL25UL

Impedance: 8 ohm or 16 ohm
70V Line or 100V Line

Max. Operating Temperature / Code at +40° Ambient	
Hazardous Location	Temperature Code
Class I, Division 2, Groups A, B, C, D	T2D (215°C)
Class II, Division 2, Groups F and G	T6 (85°C)

Max. Operating Temperature / Code at +55° Ambient	
Hazardous Location	Temperature Code
Class I, Division 2, Groups A, B, C, D	T2C (230°C)
Class II, Division 2, Groups F and G	T5 (100°C)

The equipment is suitable for use in the hazardous locations listed above or non-hazardous locations only.

PRE-INSTALLATION

WARNING – The E2xL25UL loudspeakers are supplied with flying leads so it should not be necessary to open the unit before it is installed.

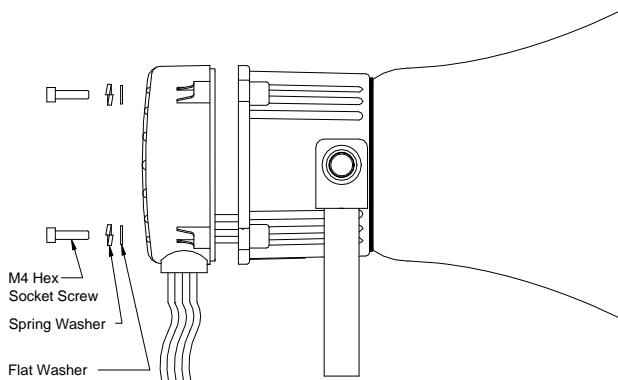

WARNING – DO NOT OPEN WHEN ENERGISED

CAUTION - DO NOT OPEN WHEN AN EXPLOSIVE GAS OR DUST ATMOSPHERE IS PRESENT

MOUNTING

The E2xL25UL loudspeaker must be mounted using the rotating bracket as shown.

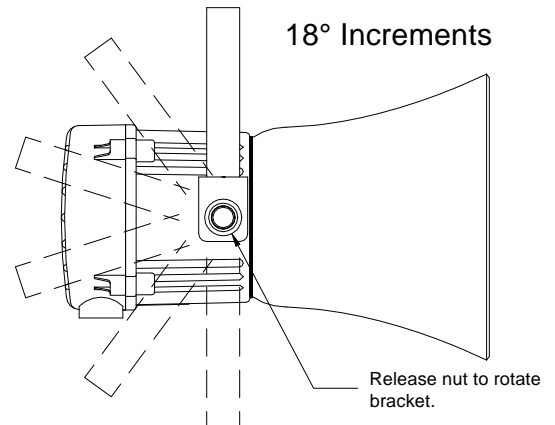

WARNING - EXPLOSION HAZARD - SUBSTITUTION OF COMPONENTS MAY IMPAIR SUITABILITY FOR CLASS I, II DIVISION 2.

WIRING INSTALLATION

The E2xL25UL loudspeaker is provided with 2 off M20 x 1.5 cable entries. 1 x ½" NPT adaptor and 1 x M20 stopping plug are provided.

Installation using Field Wiring Leads and Conduit

If the sounder is supplied pre-wired with flying leads, these are colour coded and should be connected as shown in the diagram below.

The conduit running from the supply to the sounder must include an equipment grounding conductor that is at earth potential to facilitate ground connection of the device. A number of sounders can be connected in a chain to the same supply using field installed wiring compartments that are appropriate for the hazardous location, provided that the conductor at earth potential can be readily connected to the ground lead on each sounder in the chain.

Installation using Cable Glands without Field Wiring Leads

If the sounder is supplied without field wiring leads, the cable connections are made into the terminal blocks on the electronic PCB assembly. Terminal blocks are suitable for field wiring (AWG 18-12). Strain relief has to be ensured by installation with a suitable cable gland. Follow the markings for the terminals on the PCB and install wiring as shown in the diagram below.

Cable glands need to be UL certified to ANSI/UL 2225 or C22.2 NO. 174-M1984. and to UL514B / CSA-C22.2 No. 18.3-12, ratings for hazardous locations must be equal to or better than the rating of the sounder used.

If a high IP (Ingress Protection) rating is required then a suitable sealing washer must be fitted under the cable gland.

WARNING - ALL ELECTRICAL WIRING MUST BE INSTALLED IN ACCORDANCE TO THE NATIONAL ELECTRICAL CODE

100V and 70V Loudspeakers

White Common
 Red 25 Watts
 Orange 12.5 Watts
 Yellow 6 Watts
 Violet 2 Watt
 Green/Yellow Ground

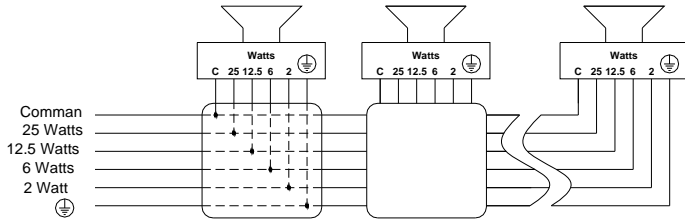

NOTE - All wires are not used they must be individually insulated to ensure that cannot make contact to any other wires.

8 ohm and 16 ohm Loudspeakers

Black Common
 Red 25 Watts
 Green/Yellow Ground

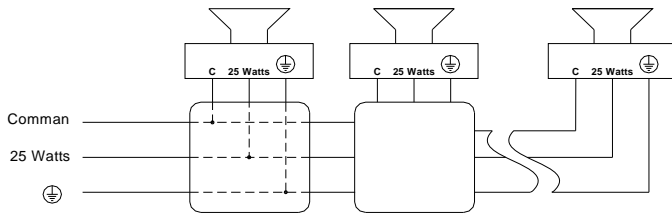

POWER AMPLIFIER SELECTION

It is important that the E2xL25UL loudspeakers are connected to power amplifiers that have outputs that are compatible to the type of loudspeaker being used. Loudspeakers with a 70V or 100V line matching transformer fitted must be connected to a power amplifier with a 70V or 100V line output. Low impedance 8 ohm or 16 ohm loudspeakers must be connected to amplifiers with a suitable low impedance output.

Unit Type	Input	Wattage	Max. I/P Volts
E2xL25UL	8 ohm	25 Watt	14.14V
E2xL25UL	16 ohm	25 Watt	20V
E2xL25UL	100V Line	25 Watt	100V
E2xL25UL	70V Line	25 Watt	70V

WARNING – HIGH VOLUME MAY CAUSE HARM TO PERSONNEL IN CLOSE PROXIMITY

1) Introduction

The E2xL25 is an ATEX, IECEx and UL certified Loudspeaker which produces a loud warning signal in a hazardous area. The Loudspeaker may be used for Gas applications in Zone 2 as well as for Dust applications in Zone 22.

2) Warnings

POTENTIAL ELECTROSTATIC CHARGING HAZARD –
CLEAN ONLY WITH A DAMP CLOTH
DO NOT OPEN WHEN AN EXPLOSIVE ATMOSPHERE IS
PRESENT.

3) Ratings and Markings ATEX/IECEx

The E2xL25 Loudspeaker complies with the following standards:

EN60079-0:2012 / IEC60079-0 ed.6.0 (2011-06)
EN60079-15:2010 / IEC60079-15 ed 4.0 (2010-01)
EN60079-31:2009 / IEC60079-31 ed2.0 (2013-11)

The Type Examination Certificate DEMKO 06ATEX0421554X / IECEx ULD 14.0012X has been issued by UL. This confirms compliance with the European ATEX Directive 94/9/EC for Group II, Category 3G/D equipment. The alarm horn carries the Community Mark and subject to local codes of practice, may be installed in any of the EEA member countries. This instruction sheet describes installations which conform to the current issue of EN60079-14/IEC60079-14 Electrical Installation in Hazardous Areas; EN60079-10-1 / IEC 60079-10-1 Explosive Atmospheres - Classification of Areas. Explosive Gas Atmospheres; EN60079-10-2 / IEC 60079-10-2 Explosive Atmospheres - Classification of Areas. Explosive Dust Atmospheres. When designing systems for installation, the local Code of Practice should be consulted.

The E2XL25 Loudspeaker is rated as follows:

	II 3G	Ex nA IIC T2 Gc Tamb -20°C to 55°C
	II 3D	Ex tc IIIC 85°C Dc Tamb -20°C to 40°C
	II 3D	Ex tc IIIC 100°C Dc Tamb -20°C to 55°C

CE Marking



Zones, Gas / Dust Groups and Temperature Classification

When connected to an approved system the E2xL25 Loudspeaker may be installed in:

- Zone 2 explosive gas air mixture not likely to occur in normal operation, and if it does, it will only exist for a short time.
- Zone 22 explosive dust air mixture not likely to occur in normal operation, and if it does, it will only exist for a short time.

May be used with gases in groups:

- Group IIA propane
- Group IIB ethylene
- Group IIC hydrogen / acetylene

Having a temperature classification (for Gas applications) of:

T1	450°C
T2	300°C

May be used with Dust types:

- Group IIIA combustible flyings
- Group IIIB non-conductive dust
- Group IIIC conductive dust

Maximum Surface Temperature for Dust Applications:

100°C
85°C (up to 40°C ambient)

3.5 Ambient Temperature Range:

-20°C to +55°C

3.6 Ingress Protection Ratings

The product is rated for ingress Protection as follows:
IP rating per EN60529: IP66

To maintain the ingress protection rating, the two cable entries must be fitted with suitably rated, certified cable entry and/or blanking devices during installation.

3.7 Electrical Ratings

Model No.	Input	Wattage	Max. I/P Volts
E2XL25UL 100V	100V Line	25W	14.14V
E2XL25UL 16R	16 Ohm	25W	20V
E2XL25UL 70V	70V Line	25W	100V
E2XL25UL 8R	8 Ohm	25W	70V

4) Special Conditions for Safe Use

Special Condition for safe Use as stated on the Type Examination Certificate DEMKO 06ATEX0421554X / CoC IECEx ULD 14.0012X

4.1 Installation

The product must only be installed by suitably qualified personnel in accordance with the latest issues of the relevant standards.

The installation of the units must also be in accordance with any local codes that may apply and should only be carried out by a competent electrical engineer who has the necessary training.

The Enclosure is non-conducting and may generate an ignition-capable level of electrostatic charges under certain extreme conditions. The user should ensure that the equipment is not installed in a location where it may be subjected to external conditions (such as high-pressure steam) which may

cause a built-up of electrostatic charges on non-conducting surfaces.

The equipment has not been assessed as a safety-related device (as referred to by Directive 94/9/EC Annex II, clause 1.5).

To maintain the ingress protection rating and mode of protection, the cable entries must be fitted with suitably rated ATEX / IECEx certified cable glands and/or suitably rated ATEX / IECEx certified blanking devices during installation according to EN / IEC60079-14. If a high IP (Ingress Protection) rating is required then a suitable sealing washer must be fitted under the cable gland.

For use in explosive gas atmospheres, a minimum ingress protection rating of IP54 must be maintained. For use in explosive dust atmospheres, a minimum ingress protection rating of IP64 must be maintained.

The enclosure is accessed by removing the 4 M4 Hex cover bolts fastening the enclosure. Do not open other joints of the enclosure for installation, service and maintenance.

Connections are to be made into the terminal blocks using solid wire, sizes 0.5-4mm² or stranded wire, sizes 0.5-2.5 mm². Wire insulation needs to be stripped 8mm. Stranded wires may be fitted securely with crimped ferrules. Terminal screws need to be tightened down with a tightening torque of 0.45 Nm.

Earthing connections should be made to the Internal Earth terminal on the PCBA. The internal earth bonding wire connects the PCBA earth terminal to the internal earth terminal in the enclosure.

Check that the earth bonding wire between the two enclosure parts is secure and the 'O' ring seal is in place before closing.

4.2 Maintenance, Repair and Overhaul

Maintenance, repair and overhaul of the equipment should only be carried out by suitably qualified personnel in accordance with the current relevant standards:

EN60079-19 / IEC60079-19 Explosive atmospheres -
Equipment repair, overhaul and reclamation
EN 60079-17/ IEC60079-17 Explosive atmospheres -
Electrical installations inspection and maintenance

Units must not be opened while an explosive atmosphere is present.

If opening the unit during maintenance operations a clean environment must be maintained and any dust layer removed prior to opening the unit.

Electrostatic charging hazard - Clean only with a damp cloth

EU Declaration of Conformity



Manufacturer: European Safety Systems Ltd.
Impress House, Mansell Road, Acton
London, W3 7QH, United Kingdom

Equipment Type: E2xS112UL, E2xS121UL
E2xB05UL, E2xB10UL
E2xCS1125UL
E2xL15UL, E2xL25UL

Directive 94/9/EC: Electrical and Mechanical equipment for use in explosive atmospheres (ATEX)

Notified Body for Type Examination:	UL International Demko A/S Notified Body No.: 0539 Borupvang 5A, 2750 Ballerup, Denmark
Type Examination Certificate:	DEMKO 06 ATEX 0421554X
Notified Body for Quality Assurance Notification:	Sira Certification Service Notified Body No.: 0518 Rake Lane, Eccleston, Chester CH4 9JN, UK
Quality Assurance Notification:	SIRA 05 ATEX M342
Provisions fulfilled by the equipment:	Ex na IIC T4/T3/T2 Gc (Ta -20°C to +55°C) Ex tc IIIC T85°C/100°C Dc (Ta -20°C to +55°C)
Standards applied:	EN60079-0:2012 + A11:2013 EN60079-15:2010 EN60079-31:2014

Directive 2014/30/EU: Electromagnetic Compatibility Directive (EMC)

Standards applied:	EN 61000-6-1:2007 EN 61000-6-2:2005 EN 61000-6-3:2007 / A1:2011 / AC: 2012 EN 61000-6-4:2007 / A1: 2011
--------------------	--

Directive 2011/65/EU: RoHS Directive

The product and all the components contained within it are in accordance with the restriction of the use of hazardous substances in electrical and electronic equipment.

On behalf of European Safety Systems Ltd., I declare that, on the date the equipment accompanied by this declaration is placed on the market, the equipment conforms with all technical and regulatory requirements of the above listed directives.

This Declaration is issued under the sole responsibility of the manufacturer.

A handwritten signature in black ink, appearing to read 'Martin Streetz', written over a horizontal line.

Martin Streetz
Quality Assurance Manager

Document No.: DC-062_Issue_A
Date and Place of Issue: London, 02/03/2015