

G3000 Fog Effects Generator w/ LSG

Operator's Manual

Table of Contents

Introduction	3
Water Base Fog Technology	3
LSG Mark II Low Fog Technology	3
Warning	3
Important Safety Instructions:	3
Safety Precautions	3
Technical Specifications	4
LSG MKII	4
LSG MKII Touring Edition	4
Technical Drawings	5
LSG Stand Alone	5
LSG Mark II w/ Cart	5
LSG w/ Road Case	6
Operating Procedure	7
LSG Mark II High Pressure using 20 or 50 lb. cylinders.....	7
LSG Mark II Low Pressure using 350lb. liquid CO2 tank	9
LSG Mark II High Power (low pressure).....	10
LSG Mark II High Power Combo	11
Low Pressure 350lb. Liquid CO2 Tank	11
Round Floor Pocket	12
Ducting	13
LSG Mark II Ducting Suggestions	14
Horizontal Ducting	14
LSG Mark II with Stage Floor Pocket	14
Fog Curtain / Waterfall	15
10" Automatic Round Damper	16
Flex to Rigid Adapter	16
Rigid Pipe Hose Adapter	16
Maintenance	17
Exterior.....	17
Heat Exchanger	17
Recommended Fluid	17
Troubleshooting Residual Buildup and Wet Output	17
Warranty	19
Contact Information	19

Note: Please read entire manual before operating the G3000 w/ LSG

Introduction

Water Base Fog Technology

Water Base Fog Technology is achieved by pumping a glycol/water mixture through a heat exchanger. This will vaporize the fluid as it passes through the processing block. The vaporization of the fluids force the hot mixture through the output nozzle. When mixed with ambient air, it forms an opaque aerosol (fog). The fog is made up of tiny droplets that form around the small particles in the air. The suspended droplets refract the light, allowing the fog to take on the color of the light illuminating it.

LSG Mark II Low Fog Technology

The patented LSG Mark II technology uses liquid CO₂ to cool the fog, generating a consistent effect at sub zero temperatures. This process enables you to produce large quantities of low lying fog on a continuous basis without cue time limitations or the messy water residue associated with other technologies. The LSG Mark II is compact and mobile facilitating most applications.

The unique partnering of a fog effect with liquid CO₂ is cost effective while providing a longer lasting effect. Designed to be utilized with the LSG Mark II, the Ultratec Special Effects genuine 'Molecular Fog Fluid' provides a dry, thick, white effect with a consistent dissipation that eliminates any ambient hazing. The "LSG Mark II" couples with the G3000, offering the most advanced controls and fog output available. The LSG Mark II consumes approximately 8 lbs. of Liquid Carbon Dioxide per minute of operation at 350 PSI.

The system can be controlled via the standard digital remote control, DMX or show control. The DMX LSG Mark II Interface allows the LSG Mark II & Fog Machine to be controlled on separate DMX channels. Standard equipment includes 10" ducting sleeve to facilitate standard ducting in many configurations based on fog distribution requirements.



Warning

Important Safety Instructions:

1. Do not touch, place hands or expose skin within 20" (50 cm) of the discharge nozzle.
2. Do not remove the outer case.
3. Persons suffering from asthma or allergenic sensitivity may experience irritation, discomfort or allergic symptoms when exposed to fog effects.
4. Ensure that this unit is grounded at all times. Failure to do so may result in serious injury.
5. Use Ultratec Special Effects fluid **ONLY**.

Safety Precautions

1. Ensure that any operation of the machine is supervised by suitably trained and authorized personnel.
2. Do not modify the machine or use a machine which has been damaged in any way.
3. Allow sufficient air circulation around the machine at all times.
4. Protect the machine from direct weather effects and wet locations.
5. Only use fluids manufactured by Ultratec Special Effects.
6. Do not continue to produce fog when visibility is reduced to 20" 50cm or below.
7. Avoid directing fog output continuously at people, structures or objects within close proximity of the discharge nozzle.
8. Ensure that adequate exhausting arrangements are available in the event of an emergency.

9. Do not place hands or exposed skin within the first 20" (50 cm) of the discharge nozzle at any time during fog production.
10. Fog effects will trigger smoke alarms and detectors. Please take suitable precautions to prevent false alarms.
11. Ensure sufficient air exchange vs. CO2 released.

Technical Specifications

Model:

LSG MKII

- CLF 3950 LSG Low Smoke Generator MKII - 120 Volt - Low Pressure Body Only
- CLF 3953 LSG Low Smoke Generator MKII - 220-240 Volt - Low and High Pressure Combo Body Only
- CLF 3955 LSG Low Smoke Generator MKII - 120 Volt - Low and High Pressure Combo Body Only
- CLF 3960 LSG Low Smoke Generator MKII - 120 Volt - High Pressure Body Only
- CLF 3962 LSG Low Smoke Generator MKII - 220-240 Volt - High Power Body Only
- CLF 3985 LSG Low Smoke Generator MKII - 120 Volt - Low Pressure w/ Cart
- CLF 3986 LSG Low Smoke Generator MKII - 220-240 Volt - Low Pressure w/ Cart
- CLF 3990 LSG Low Smoke Generator MKII - 120 Volt - High Pressure w/ Cart
- CLF 3994 LSG Low Smoke Generator MKII - 120 Volt - Low and High Pressure Combo w/ Cart
- CLF 4011 LSG Low Smoke Generator MKII - 120 Volt - High Power w/ Cart
- CLF 4012 LSG Low Smoke Generator MKII - 120 Volt - High Power Body Only
- CLF 3951 LSG Low Smoke Generator MKII - 220-240 Volt - Low Pressure Body Only
- CLF 3961 LSG Low Smoke Generator MKII - 220-240 Volt - High Pressure - Body Only
- CLF 3991 LSG Low Smoke Generator MKII - 220-240 Volt - High Pressure w/ Cart
- CLF 3993 LSG Low Smoke Generator MKII - 220-240 Volt - Low and High Pressure Combo w/Cart
- CLF 3997 LSG Low Smoke Generator MKII - 120 Volt - High Power Combo w/Cart
- CLF 3998 LSG Low Smoke Generator MKII - 120 Volt - High Power Combo Body Only

LSG MKII Touring Edition

- CLF 3975 LSG Low Smoke Generator MKII - 120 Volt - Low Pressure w/ Road Case
- CLF 3980 LSG Low Smoke Generator MKII - 120 Volt - High Pressure w/ Road Case
- CLF 3992 LSG Low Smoke Generator MKII - 120 Volt - Low and High Pressure Combo w/ Road Case
- CLF 3996 LSG Low Smoke Generator MKII - 120 Volt - High Power Combo w/ Roadcase
- CLF 4010 LSG Low Smoke Generator MKII - 120 Volt - High Power w/ Roadcase
- CLF 3976 LSG Low Smoke Generator MKII - 220-240 Volt - Low Pressure w/ Roadcase
- CLF 3981 LSG Low Smoke Generator MKII - 220-240 Volt - High Pressure w/ Roadcase
- CLF 3988 LSG Low Smoke Generator MKII - 220-240 Volt - Low and High Pressure Combo w/Road Case
- CLF 3999 LSG Low Smoke Generator MKII - 220-240 Volt - High Power Combo w/Road Case

Type:

CO2 operated fog chilling unit w/
G3000 - Water base fog generating system

Size:

See illustrations that follow

Weight:

Installation version w/ cart: 100lbs less G3000

Roadcase version: 150lbs less G3000

Power Rating:

120 Volt A.C. 50/60 Hz. 20 Amps. (w/ G3000)
220-240 Volt A.C. 50/60 Hz. 10 Amps. (w/ G3000)

LSG w/ Road Case

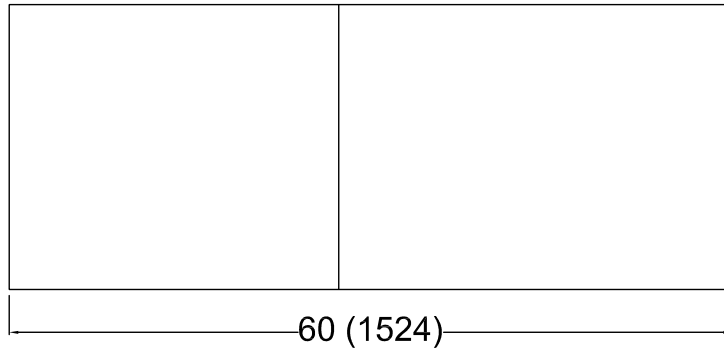

60 (1524)

TOP VIEW

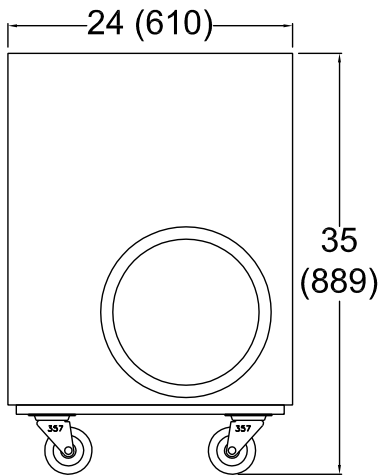

FRONT VIEW

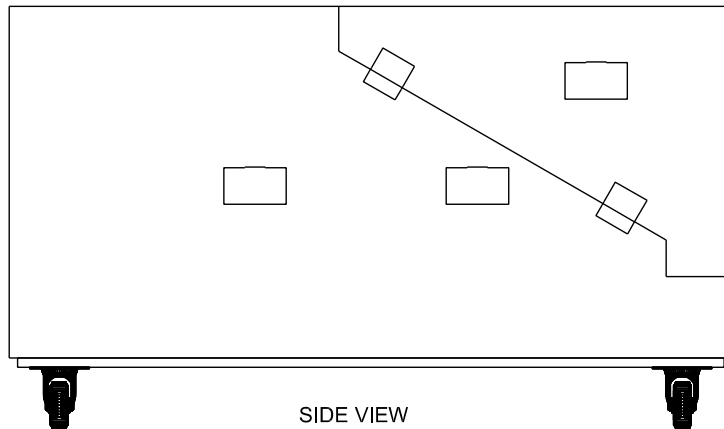

SIDE VIEW

Operating Procedure

LSG Mark II High Pressure using 20 or 50 lb. cylinders

1. Place the G3000 output directly against the foam gasket of the LSG Mark II.

TECH TIP: Proper alignment can be observed by shining a flashlight into the 10" exit of the LSG Mark II and noting the G3000 output nozzle is centered in the LSG Mark II input.

2. Connect the grey twist lock connector from the LSG Mark II into Custom port on the rear panel of the G3000.
3. Power up the fog machine by turning on the power switch.

Detailed G3000 operating instructions located in G3000 Operators Manual



For Remote Operation

When connected to an LSG, set the desired time for the LSG to inject CO2 before the G3000 begins to produce fog.

(0-2 Minutes)

NOTE: This delay allows the liquid CO2 to purge the supply hose of CO2 gas and pre chill the LSG before starting to fog. The recommended formula for calculating delay time is 1 sec. for every three feet of supply hose.



For DMX Operation

Using the "+" or "-" buttons select the desired valid DMX address. (0-511)

Data = fog rate controlled 0-100%,
DMX+1=LSG power on above 50%.

↑
0-255

↑
0-255
128 - Relay

4. Adjust the remote flow rate to desired fog output level. It is recommended to start at 50% and adjust accordingly. The maximum recommended flow for the LSG Mark II High is 75%.
5. An LSG Mark II High requires high pressure CO2 bottles. These are normally available in 20 or 50 lb sizes. For ease of use it is recommended that bottles with liquid siphon tubes be used.

We do **NOT** recommend inverting the 50 lb. cylinders as they may pose a tipping hazard. Use 50 lb. cylinders equipped liquid siphon tubes.

6. The second connection to be made is the CO2 supply hose. A sealing washer is necessary to prevent leaks and are available from your gas supplier.
7. Tighten the CO2 supply fitting snug with appropriate wrench .
8. Open valve slowly to check for leaks then open fully, by turning counter-clockwise and then closes 1/4 turn.
9. When the G3000 is up to operating temperature, turn on the fog on the remote control. The CO2 will be activated

first. After the appropriate delay time passes, fog issue will start. You will know when the gas has been purged from the supply hose by the difference in noise that the LSG Mark II makes.

10. Verify cool temperature output using your hand, by passing it through the fog output noting the temperature.

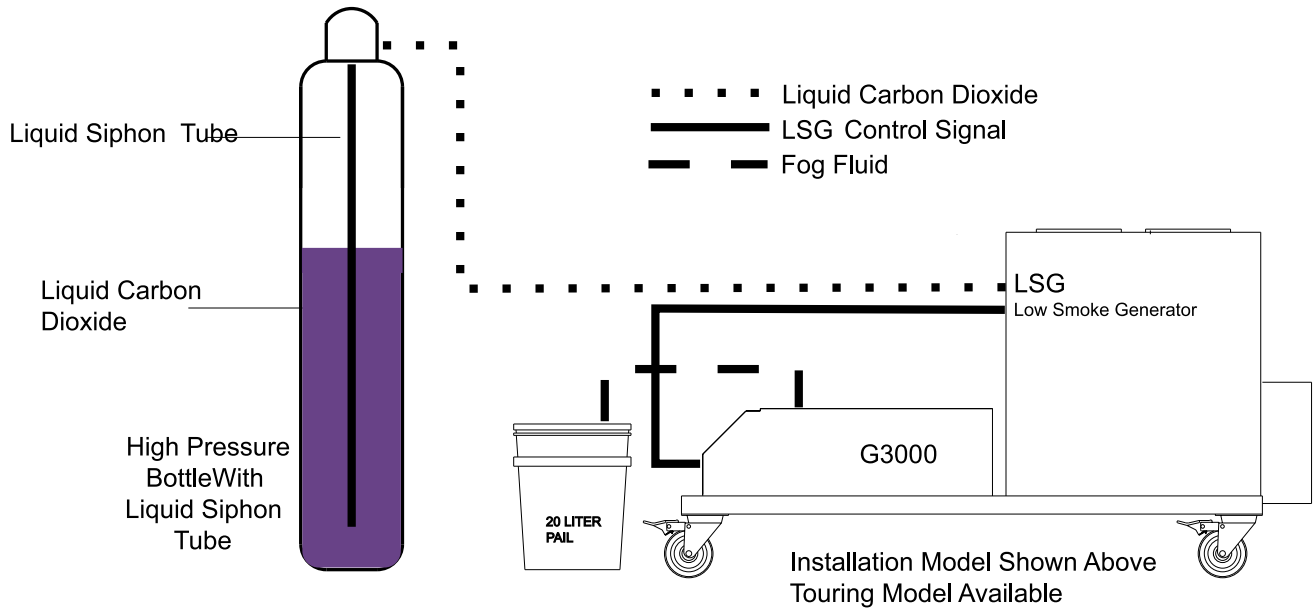

LSG Mark II Low Pressure using 350lb. liquid CO2 tank

These instructions are given for systems using a G3000 with LSG Control Option. Alternate control options are given further in this manual.

1. Place the G3000 output directly against the foam ring input of the LSG Mark II.

TECH TIP: Proper alignment can be observed by shining a flashlight into the 10" exit of the LSG Mark II and noting the G3000 output nozzle is centered in the LSG Mark II input.

2. Connect the blue Twist lock connector from the LSG Mark II into Custom port on the rear panel of the fog machine.

3. Power up the G3000 by turning on the power switch.

Detailed G3000 operating instructions located in G3000 Operators Manual



For Remote Operation

When connected to an LSG, set the desired time for the LSG to inject CO2 before the G3000 begins to produce fog.

(0-2 Minutes)

NOTE: This delay allows the liquid CO2 to purge the supply hose of CO2 gas and pre chill the LSG before starting to fog. The recommended formula for calculating delay time is 1 sec. for every three feet of supply hose.



For DMX Operation

Using the "+" or "-" buttons select the desired valid DMX address. (0-511)

Data = fog rate controlled 0-100%,
DMX+1=LSG power on above 50%.

↑
0-255

↑
0-255
128 - Relay

4. Adjust the remote flow rate to desired fog output level. It is recommended to start at 50% and adjust accordingly. The maximum recommended flow for the LSG Mark II Low is 75%.
5. An LSG Mark II Low requires a 350 lb. Low Pressure Liquid CO2 Tank. You must connect the supply hose to the Liquid output of the Liquid CO2 Tank. This is usually clearly indicated on the Liquid CO2 Tank outputs.
6. The second connection to be made is the CO2 supply hose. This is connected to the liquid port of the CO2 supply.
7. A sealing washer is necessary to prevent leaks and are available from your gas supplier.
8. Tighten the CO2 supply fitting snug with appropriate wrench.
9. The Liquid CO2 Tank pressure as indicated on the pressure gauge must read between 300-340 psi to operate the LSG Mark II, this is achieved by opening the pressure builder valve at least one to three hours in advance of use by

turning counter clockwise.

10. Open valve slowly to check for leaks then open fully, by turning counter-clockwise and then closes 1/4 turn.
11. When the G3000 is up to operating temperature, turn on the fog button on the remote control. The CO2 will be activated first. After the appropriate delay time passes smoke issue will start. You will know when the gas has been purged from the supply hose by the difference in noise that the LSG Mark II makes.
12. Verify cool temperature output using your hand, by passing it through the fog output noting the temperature.

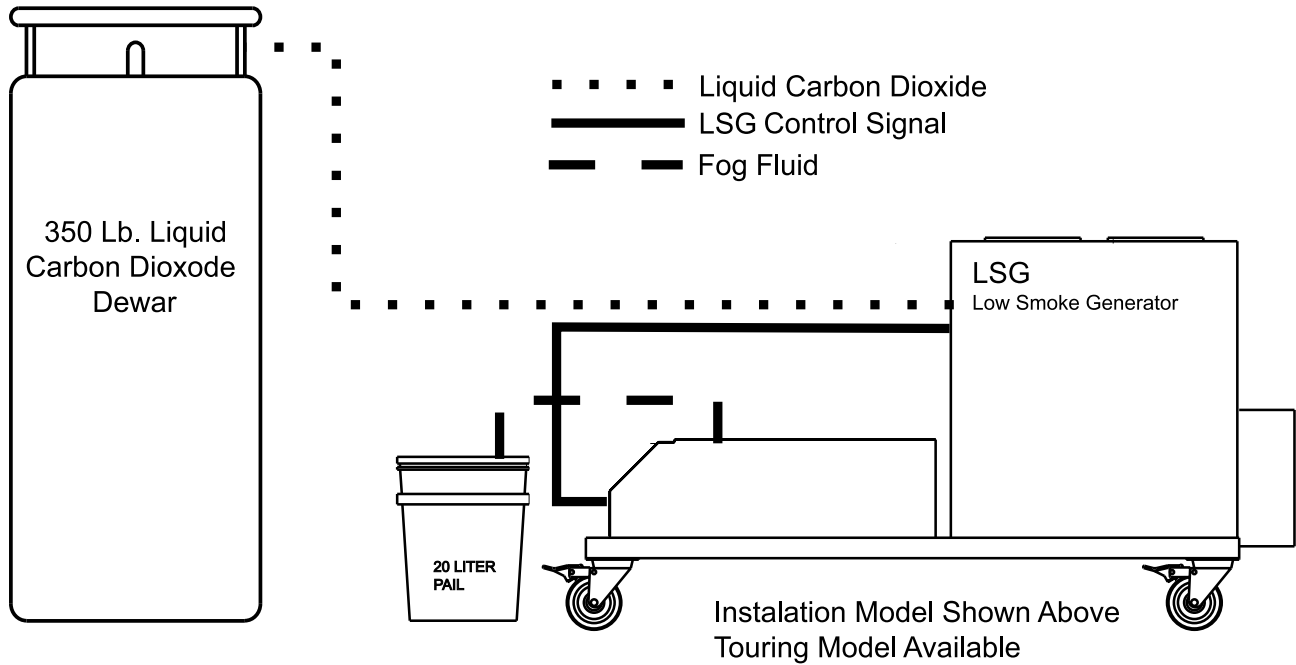

LSG Mark II High Power (low pressure)

The LSG High Power features dual (low pressure) valve operation as well as variable fan speed. The valves can be operated independently for 50% flow, 100% flow or combined 50% boost (150%). Both fan speed and valve activation are controlled by either the handheld remote or the DMX Interface - both included.

Remote: 50% button controls - relay 1
 100% button controls - relay 2
 Fan Speed dial controls fan, from ccw = off to cw = full speed

DMX Control: Channel x controls Fan Speed < 25% = off
 Channel x + 1 controls 50% Flow (or relay 1)
 Channel x + 2 controls 100% Flow (or relay 2)

LSG Mark II High Power Combo

(low pressure/high power or high pressure standard)

The LSG MKII High Power Combo has the same features as the High Power, but also provides for the use of high pressure Liquid CO2 at standard output (non High Power)

Remote: 50% button
 100% button (Not used with High Pressure Liquid CO2)
 Fan Speed dial controls fan - Off (CCW) & On (CW)

Note: When used in a High Pressure Liquid CO2 in Standard Mode, only use the 50% button. The High Pressure Liquid CO2 will cause the 100% valve to freeze.

DMX Control: Control x controls Fans Speed < 25% = Off
 Channel x + 1 controls 50% Flow, used with High Pressure Liquid CO2
 Channel x + 2 1000% Flow, NOT used with High Pressure Liquid CO2

Note: When using the LSG High Power, the G3000 delay is controlled either manually via remote or via DMX. When fog and/or CO2 are activated, the LSG fan speed should be at least 25% to prevent back flow.

Low Pressure 350lb. Liquid CO2 Tank

The LSG Mark II Low Pressure uses CO2 Cylinders similar to the one pictured to the right. These are available from the local welding supply centre, or look in the Yellow Pages under "Carbonics" and are sometimes referred to as "Dewars". Typically there are three valve handles, a pressure gauge and a CO2 level indicator located on the top of the Liquid CO2 Tank. These valves handles should be labelled as Gas/Vent, Liquid and Pressure Builder. We will cover each of these below.



Gas Vent

This is used if a CO2 gas supply is utilized. As we only use the liquid supply to operate the LSG Mark II, this valve is not opened.

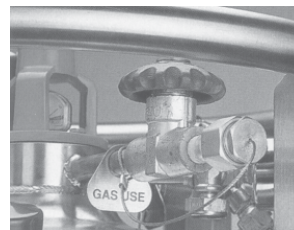

Liquid

This is the source of our liquid supply of CO2. The LSG Mark II CO2 supply hose is threaded onto the valve outlet, being sure to use the appropriate sealing washer and tighten to eliminate any leaks. When ready to operate the LSG Mark II, open the Liquid valve fully by turning counter clockwise and then close 1/4 turn.

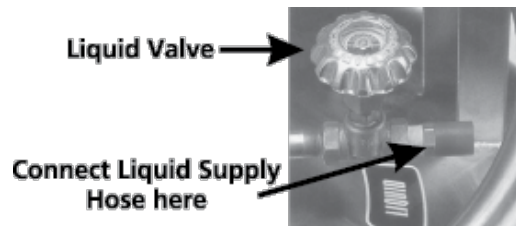

Pressure Builder

The pressure builder is a very important component in achieving the proper LSG Mark II operating pressure. We can monitor this operating pressure by observing the pressure gauge located on the top of the Liquid CO2 Tank.

Ideally the operating pressure of the Liquid CO2 Tank is 310 - 330 PSI. This is achieved by opening the pressure builder valve prior to operating the LSG Mark II.

TECH TIP: Building the pressure to the proper level may take up to an hour so it is suggested that the Pressure Builder valve be fully opened one to three hours before use.

NOTE: The Liquid CO2 Tank is equipped with a pressure relief valve that is fixed to open at 350 PSI. The pressure relief valve is in place to ensure the internal Liquid CO2 Tank pressure does not exceed 350 PSI. As you approach the ideal operating pressure the relief valve may open slightly and release CO2 gas. Although this is sometimes noisy this is no cause for alarm, simply close the pressure builder valve by turning clockwise.

NOTE: These tanks vent 1-2% daily to maintain their cold temperature. They must be stored in a well ventilated area to prevent dangerous CO2 accumulation.

Pressure Builder Valve

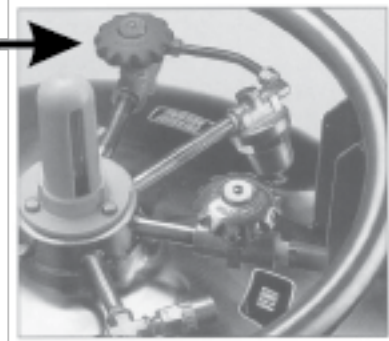

Round Floor Pocket

The Round Floor Pocket is designed to be flush mounted into the stage floor and is pneumatically powered and electrically controlled. The Floor Pocket connects to either our 10" Rigid or 10" Flex Hose. DMX control can be obtained by using a DMX relay control like the CLF 2944 LSG DMX Interface (110 Volt). The Floor Pocket may be mounted shown in the illustration.

1. Layout a 10 3/4" diameter and a 12 3/4" diameter hole on the same centers onto the stage floor.
2. Cut a through hole into the stage on the 10 3/4" diameter markings.
3. Route away approximately a 5/16" recess in the remaining 12 3/4" diameter layout for the recess.
4. Insert the floor pocket into the hole cut into stage noting the orientation of the fog deflector (if being used).
5. Mount the Flush Mount Ring over the Floor Pocket while aligning screw holes and fasten using screws provided.

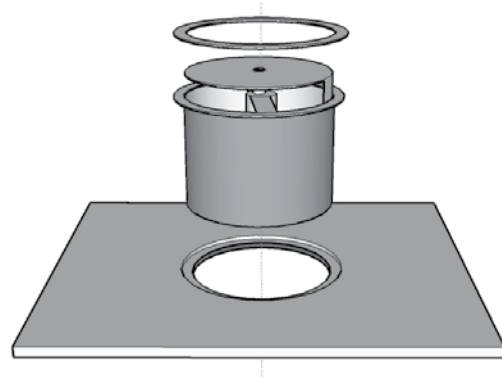

The Floor Pocket uses very little compressed air or gas to operate, a 1/4" diameter air supply may be attached to the Floor Pocket feed hose using the supplied Push Lock connector.

The Floor Pocket opens when power is applied and closes when power is removed.

CLF-2979 Round Floor Pocket - 110v

CLF-2980 Round Floor Pocket - 220-240v

Floor Pocket Diagram:

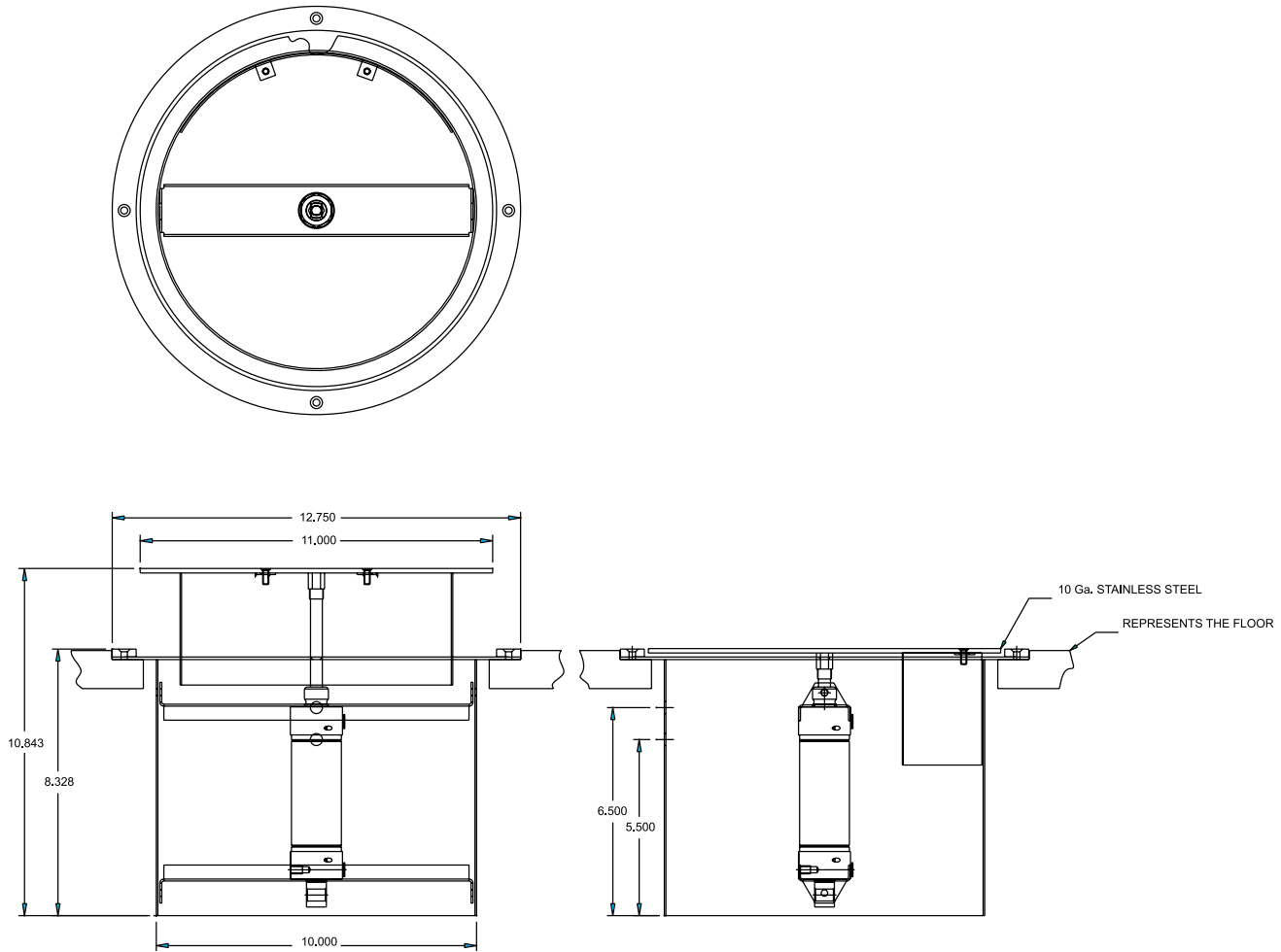

Ducting

If ducting is required the LSG Mark II output requires a 10" flexible duct, and can be ducted up to 50 feet horizontally. The ducting is available insulated or non-insulated and can be purchased through an industrial supply company or from Ultratec Special Effects.

The LSG Mark II may also be ducted vertically up to 20 feet to produce a waterfall or cascade effect. When ducting fog vertically, the remaining fog in the duct must not be allowed to backflow into the LSG Mark II. When this happens repeatedly the glycol in the fog may condensate on the inside of the G3000, damaging the electronic components. See further in this manual for suggested solutions and ducting examples.

TECH TIP: If dividing the output to more than one location while ducting, make sure the sum of all cross sectional areas of the final duct sizes are equivalent or greater than the cross sectional area of the LSG Mark II 10" outlet. Doing this will prevent any backpressure being created by the LSG Mark II.

The formula for cross sectional area: $0.78539 \times (\text{diameter squared})$

Example:

The LSG Mark II outlet has a diameter of 10": $0.78539 \times 100 = 78.5$ square inches is the area of the LSG Mark II outlet.

If you require 3 locations to duct the effect to, then the cross sectional area of the 3 ducts must be greater than

78.5" square inches. For this example, we will try a 6" diameter duct: $0.78539 \times 36 = 28$

If we multiply the cross sectional area of the 6" duct by 3 duct outlets : $28 \times 3 = 84$ ". 84 is greater than 78.5 so the 6" ducting split into 3 ducts is acceptable. Some form of dampening may have to be used to balance the output of different sized outputs.

LSG Mark II Ducting Suggestions

Horizontal Ducting

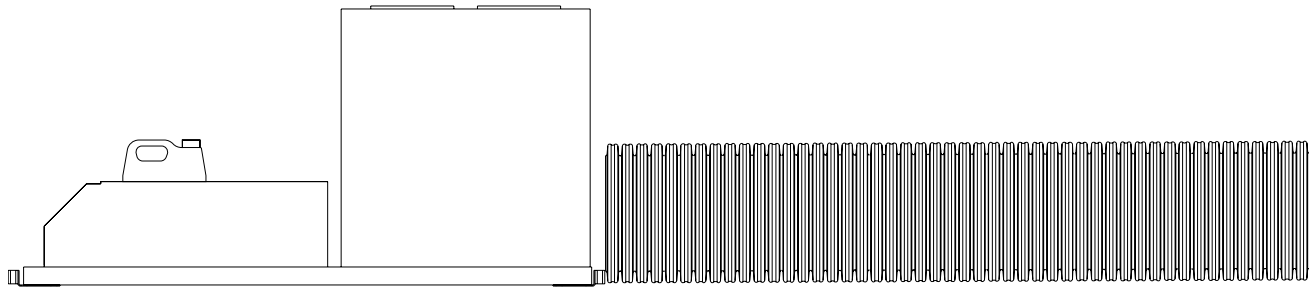

No Backflow Prevention Necessary

LSG Mark II with Stage Floor Pocket

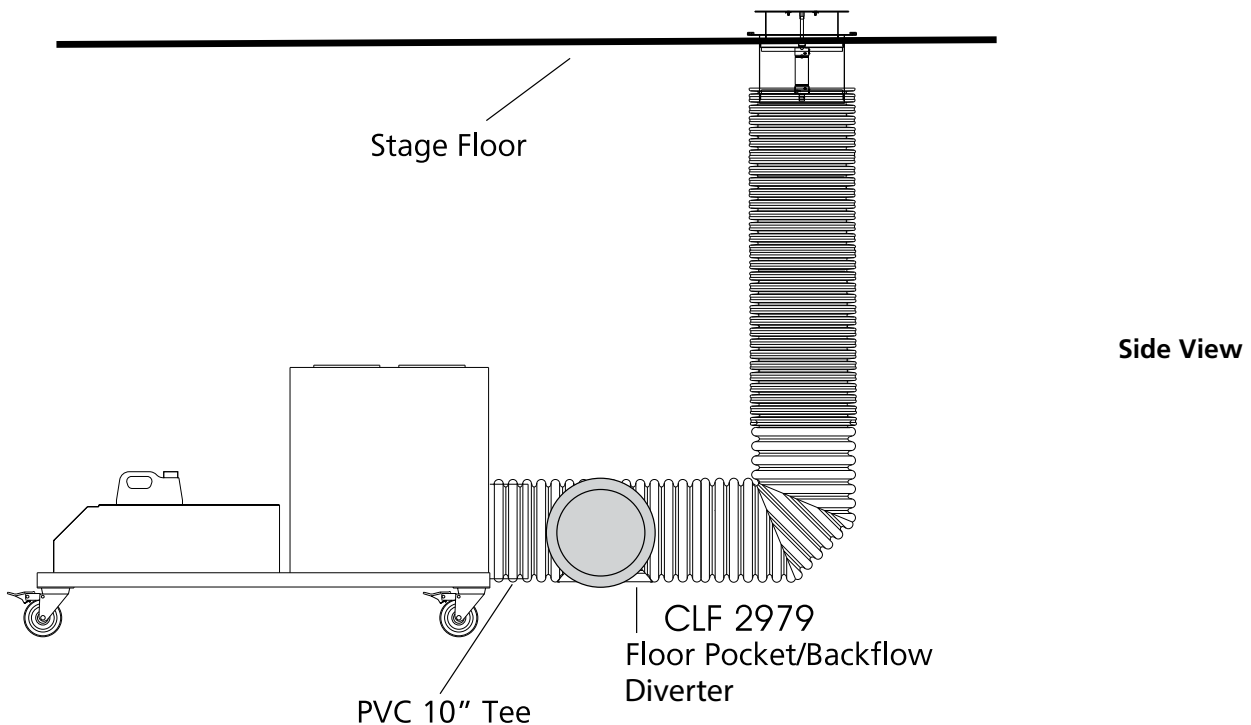

Top View

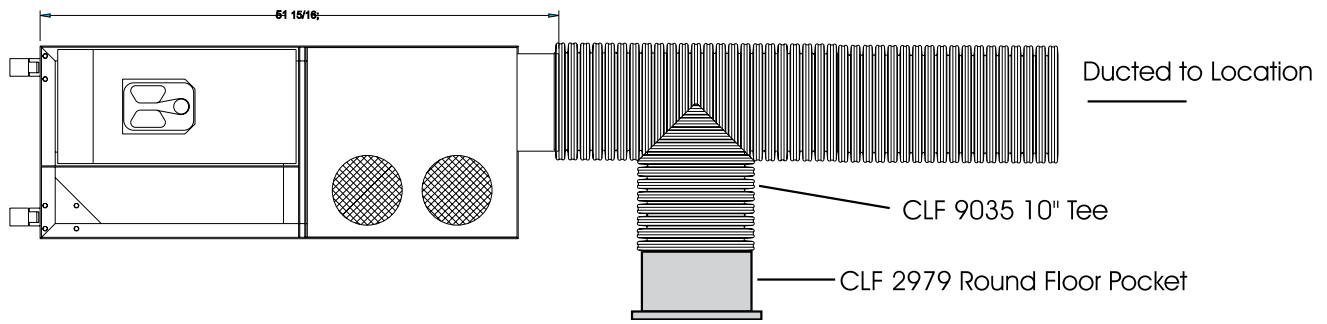

Fog Curtain / Waterfall

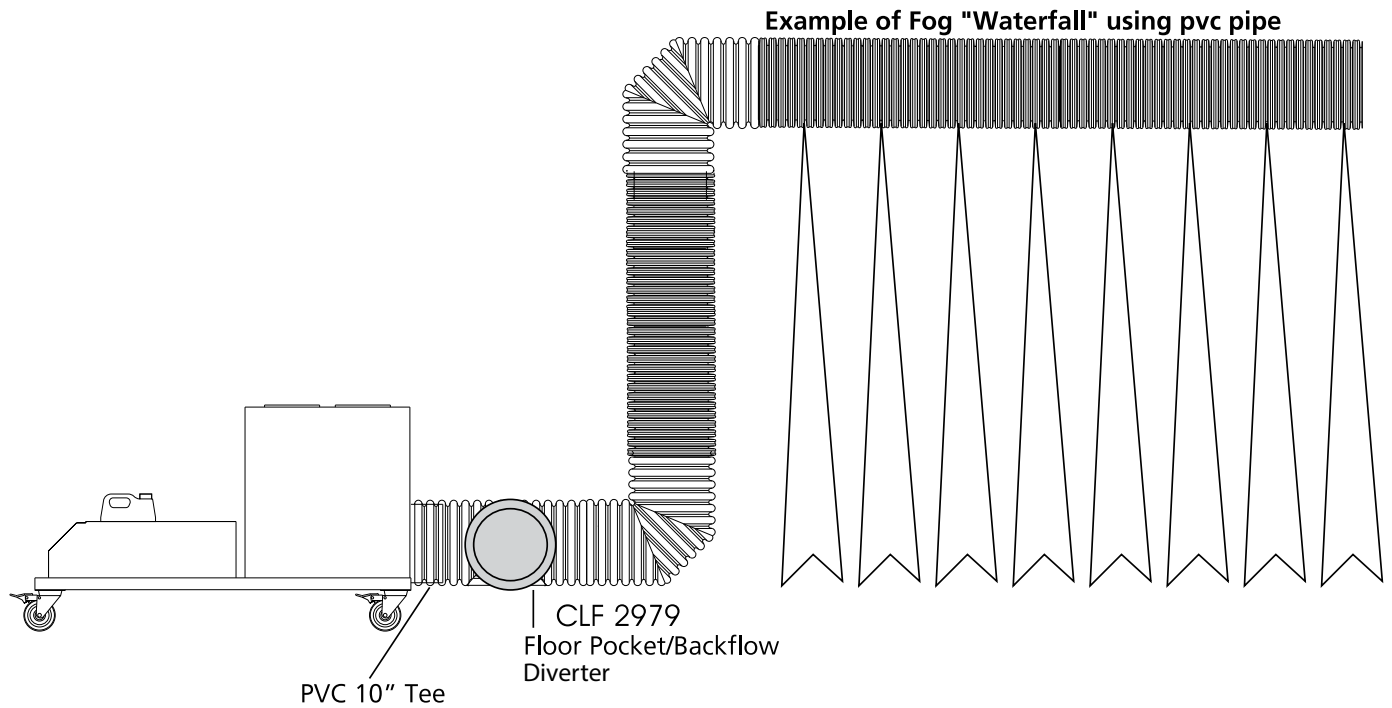

10" Automatic Round Damper

The 10" Automatic Round Damper (ARD) is an inline damper that will open or close to allow or prevent fog from flowing down a run of 10" ducting. When using with a 'Y' connector as illustrated, fog may be diverted down either or both branches of ducting. The unit operated using 110 VAC and may be field set to open or close upon receiving power. Two leads are provided for power connection. The ARD is constructed of galvanized steel and fits inside 10" rigid pipe and held with sheet metal screws or inside a 10" flex pipe and held with a worm gear clamp.

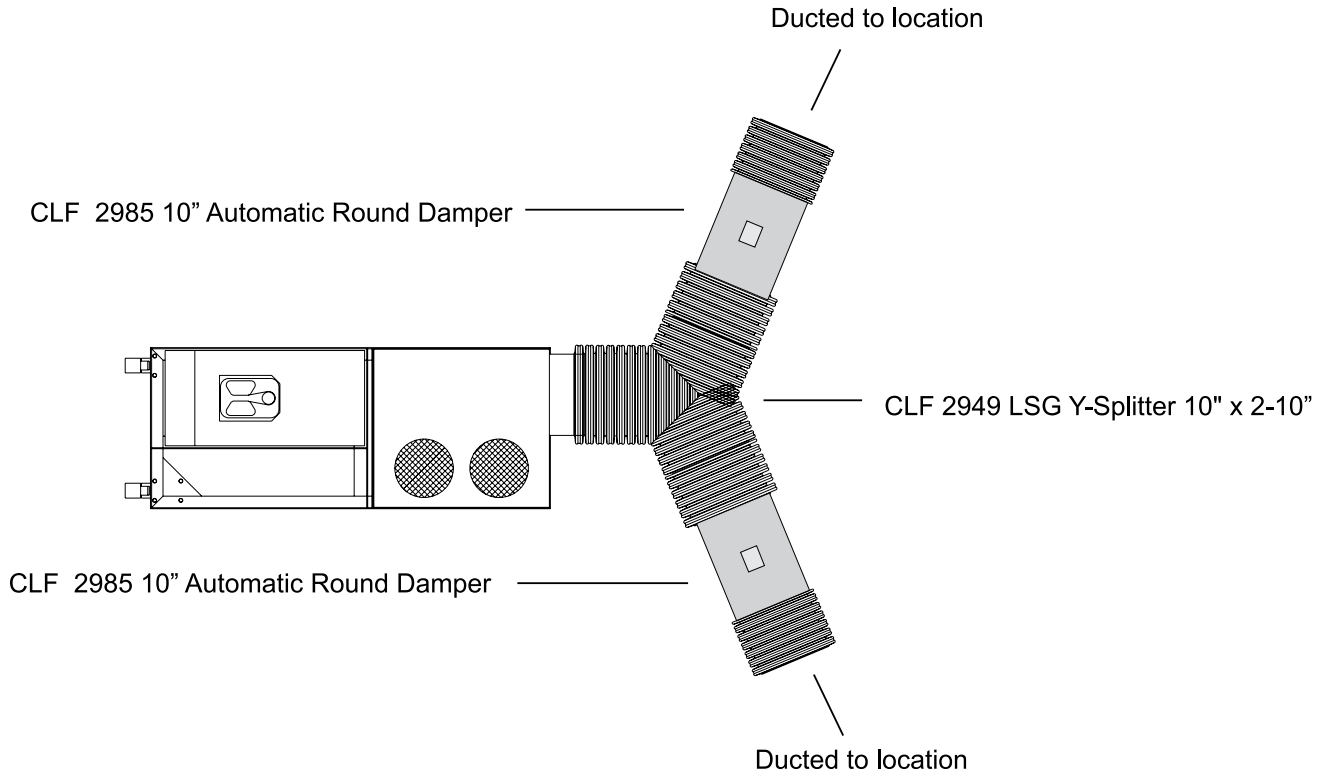

DMX control can be obtained by using a DMX relay control like the CLF 2944 LSG DMX Interface 110 Volt. The ARD may also be used as a cost effective back flow prevention device.

Flex to Rigid Adapter

The CLF 9033 10" Adaptor (Flex Hose to Rigid) is used when a connection between flex hose and rigid pipe is needed.

Rigid Pipe Hose Adapter

CLF 2957 LSG MKII Rigid Pipe Hose Adaptor is used with the LSG Touring Road Case model and extends the LSG fog output to outside the road case where pipe connections can be made easier.

Maintenance

Exterior

The casing of the G3000 is stainless steel with a powder paint coating. To clean simply wash with mild soap and warm water.

Heat Exchanger

Using high quality Ultratec Special Effects fluid should result in a long heat exchanger life. (See warranty policy outlined on the last page of this document).

Note: Cleaning/Rapid Change procedure located in G3000 Service Manual.

Recommended Fluid

Quick Dissipating Fog Fluid: This fast dissipating fluid is great for applications or effects that require quick dissipation of fog. It produces excellent steam effects that resemble nitrogen bursts and it also keeps low-lying fog from rising too quickly when it is used with the LSG or LSX.

Extra Quick Dissipating Fog Fluid: Dissipates 2x the rate of Quick Dissipating Fog Fluid while maintaining similar characteristics.

Molecular Fog Fluid: A faster dissipation versus the Director's Choice Fog Fluid. This thick, clean, white fog is an optimal solution for a dense low-lying fog effect when chilled with the LSG or LSX machines.

All of our Fog Fluids are water based. Damage will occur if Haze Fluid is used in the G3000.

There will always be some residue in the LSG as it is using two opposing forces to create the effect; hot fog and cold gas.

Troubleshooting Residual Buildup and Wet Output

The following list of items may cause wet output or residue to form:

1. Low CO2 Pressure, less than 275 PSI. Check to ensure the Pressure Builder Valve is turned on and the pressure is over 300 PSI. before use. Monitor the pressure through the cue to see if the pressure does not drop below 275 PSI. If it does, residue will begin to form.
2. With the use of Mini Dewars this some times becomes a problem. Many Gas filling Stations do not correctly fill the Mini Liquid CO2 Tank and may cause them not to perform as well as large Dewars. This can be overcome by adding a High Pressure 20 lbs cylinder and regulator or going to full size Dewars.
3. The LSG Mark II must always use the Liquid CO2 from the Liquid CO2 Tank NOT the Vapour.
4. If using ducting the duct may have a kink or some kind of obstruction in it.
5. Fog machine nozzles are not straight out of the machine. These must be straight to ensure the fog can fully expand. Visually check the copper tubes at the fog machine output to ensure the fog is exiting the output. If they are not, use a pair of pliers and adjust. (Be careful as they may be extremely HOT).
6. Fog Machine is not lined up with the entry hole. This is where the fog machine meets the LSG Mark II. If this does not meet direct and straight the fog can not expand fully. Take a flashlight and shine it through the 10" opening of the LSG Mark II and look through to the input to see if it is lined up properly.
7. The fog machine is not processing the fog properly. Remove the machine from the LSG Mark II, turn on the fog machine and place your hand in the fog stream 24" away from the front of the machine. Your hand should be dry. You will feel a slight warming but do not confuse this for moisture. If the machine is not performing

properly, your hand will be very wet. The fog machine should be serviced to rectify the problem.

8. Too much fog is being pushed through the LSG Mark II. On the High Pressure LSG Mark II we would recommend less than a 20 Flow Rate setting on the fog machine remote. On the Low Pressure LSG Mark II we would recommend Less than a 25 Flow Rate setting on the fog machine remote.
9. Wrong Fluid is being used. Ultratec Special Effects Molecular should be the only fluid used. Longer lasting fogs can cause this but again it is not observed often. If another manufacturers fluid is used this will definitely cause this type of problem.
10. The LSG needs as much free air as possible to operate correctly. If the LSG is locked up in a confined area poor output and overheating of the fog machine will occur.
11. The LSG Mark II Valve is defective or damaged and is not allowing enough Liquid CO2 into the LSG Mark II.
12. The LSG Mark II is damaged and is not getting good air flow.
13. The internal air expanding unit is damaged or has come dislodged from it's mounting device.

If you are experiencing a residue problem, and the above checklist has failed to solve the problem, please call Ultratec Special Effects or e-mail service at service@ultratec.com for assistance in rectifying the problem.

Warranty

Warranty:	Hardware products come with a one year warranty on parts and labor. Unless stated otherwise, this will refer to manufacturer defects only. All warranty is based on destination of the original sale. Any additional costs incurred are the responsibility of the Dealer and/ or the customer. Abuse or poor maintenance is not accepted. Proof of purchase or proof of sale must always accompany all warranty returns. An RA (Return Authorization) number must be noted on the outside of each box being returned to our facility. Any package(s) without an RA number clearly marked, will not be accepted by our receiving department. Freight on warranty items are freight prepaid to our facility and we will prepay freight back to your facility following repair. This will be done by the most economical means available. Should you require the item express-returned, the dealer is responsible for request indication and any difference in freight cost. Export Distributors are required to carry out the warranty repair, parts will be supplied by Ultratec.
Return Policy:	Return of any product must be done within 30 days of purchase. The package must be returned freight prepaid and the RA number clearly marked on the outside of the box.
Warning:	Ultratec Special Effects considers all of its product to be safe for use in the application it was intended. Ultratec Special Effects takes no responsibility for misuse or incorrect use. Always refer to the Product Manual for proper use.

Contact Information

Head Office

Ultratec Special Effects
1960 Blue Heron Drive
London, Ontario N6H 5L9

Direct: 519-659-7972
Toll Free: 866-534-5557
Fax: 519-659-7713

Europe Office

Ultratec Special Effects GmbH
Dieselstrasse 30-40
60314
Frankfurt am Main
Germany

Direct: 49-69-87-000-1850
Fax: 49-69-87-000-1899

Canadian Shipping Address

(For All Canadian Repairs)
Ultratec Special Effects
1960 Blue Heron Drive
London, Ontario N6H 5L9

USA Shipping Address

(For All USA Repairs)
Ultratec Special Effects
640 Gadson Street
Groveland, Florida 34736

Please remember to include the **RA Number on all items being shipped for repairs.**

To retrieve an RA Number visit www.ultratecfx.com and click on the "Service" section. Then click on "Return Authorization Request" which is located on the left hand side of the page.

If you have any questions or require assistance please contact service at 519-951-3357/866-534-5557 or by email at Service@Ultratecfx.com.