



# INSTRUCTIONS

-J05648

REV. 2013-12-13

## ELECTRA GLO™ TRIM RING KITS FOR SEVEN INCH HEADLAMP

### GENERAL

#### Kit Numbers

61400154, 61400155

#### Models

For model fitment information, see the P&A retail catalog or the Parts and Accessories section of [www.harley-davidson.com](http://www.harley-davidson.com) (English only).

#### Installation Requirements

Electrical Contact Lube (Part No. 99861-02) or equivalent is required for all unprotected electrical terminals, and after battery cable disconnection. This item is available from a Harley-Davidson dealer.

Use an assistant to aid in the testing procedure.

#### WARNING

The rider's safety depends upon the correct installation of this kit. Use the appropriate service manual procedures. If the procedure is not within your capabilities or you do not have the correct tools, have a Harley-Davidson dealer perform the installation. Improper installation of this kit could result in death or serious injury. (00333a)

#### NOTE

This instruction sheet refers to service manual information. A service manual for this year/model motorcycle is required for this installation. One is available from a Harley-Davidson dealer.

### ELECTRICAL OVERLOAD

#### NOTICE

It is possible to overload your vehicle's charging system by adding too many electrical accessories. If the combined electrical accessories operating at any one time consume more electrical current than the vehicle's charging system can produce, the electrical consumption can discharge the battery and cause damage to the vehicle's electrical system. See an authorized Harley-Davidson dealer for advice about the amount of current consumed by additional electrical accessories or for necessary wiring changes. (00211c)

#### WARNING

When installing any electrical accessory, be certain not to exceed the maximum amperage rating of the fuse or circuit breaker protecting the affected circuit being modified. Exceeding the maximum amperage can lead to electrical failures, which could result in death or serious injury. (00310a)

This kit requires up to 180 mA more current from the electrical system.

#### Kit Contents

See Figure 2 and Table 1.

### PREPARATION

#### For Vehicles With Main Fuse:

#### WARNING

To prevent accidental vehicle start-up, which could cause death or serious injury, remove main fuse before proceeding. (00251b)

#### NOTE

- **For 2007- later vehicles equipped with security siren:** With security fob present, turn ignition switch ON. After system is disarmed, turn ignition switch OFF. **IMMEDIATELY** remove the main fuse per the service manual.
  - **For 2006- earlier vehicles equipped with security siren:** Disarm the siren with the key fob or security code. See the service manual to remove the main fuse.
  - **For vehicles WITHOUT security siren:** See the service manual to remove the main fuse.
1. **All models:** Remove seat. Retain the seat and all mounting hardware.

#### For Vehicles With Main Circuit Breaker:

#### WARNING

To prevent accidental vehicle start-up, which could cause death or serious injury, disconnect battery cables (negative (-) cable first) before proceeding. (00307a)

#### WARNING

Disconnect negative (-) battery cable first. If positive (+) cable should contact ground with negative (-) cable connected, the resulting sparks can cause a battery explosion, which could result in death or serious injury. (00049a)

1. **For vehicles equipped with security siren:** Disarm the siren with the key fob or security code.  
**All models:** See the service manual to remove the seat. Retain all seat mounting hardware.  
Disconnect negative battery cable. Disconnect positive battery cable. Retain all seat mounting hardware.
2. Turn ignition switch OFF unless already done.

## INSTALLATION

1. Remove the currently installed headlamp trim ring per the service manual. Retain the mounting screw.
2. See Figure 2. Install the **new** Electra Glo trim ring (1) to the vehicle with the mounting screw from Step 1.
3. Route the trim ring wires (A) into the nacelle and out the left side of the frame.
4. See Figure 1. Insert the trim ring wire socket terminals into the connector (2) from the kit per the Tyco/AMP connector section of the service manual:
  - Orange/White wire into Cavity 1.
  - Black wire into Cavity 2.

### NOTE

If also installing an *Electra Glo Trim Ring Kit for 4.5 in auxiliary lamps*, install **that** kit now.

5. **FLSTC models:** Unplug the fender tip lamp connector [143] near the left side of the steering neck.
6. **FLSTC models:** Plug the trim ring wiring connector into the jumper harness (3) from the kit. Plug the jumper harness into the open fender tip lamp connector.  
**All other Softail models:** Plug the trim ring wiring connector into the open headlamp connector [143] near the left side of the steering neck.
7. **ALL models:** Use the cable straps (4) and adhesive backed clips (5) from the kit to secure the wiring. Make sure wires do not pull tight when handlebars are turned fully to left or right fork stops.

## COMPLETION

### WARNING

Be sure that steering is smooth and free without interference. Interference with steering could result in loss of vehicle control and death or serious injury. (00371a)

- Make sure wires, clutch cables, throttle/idle cables and brake lines do not pull tight when handlebars are turned fully to left or right fork stops.

### NOTE

Verify that the ignition is **OFF** before installing the main fuse or attaching the negative battery cable.

1. **Models with main fuse:** See the service manual to install the main fuse.  
**Models with main circuit breaker:** See the service manual to attach the negative battery cable. Apply a light coat of Electrical Contact Lube (Part No. 99861-02) or equivalent to battery terminals.
2. Test the Electra Glo Trim Ring for proper operation:
  - a. Turn ignition switch OFF. Trim ring LEDs are OFF.
  - b. Turn ignition switch to ACC. Trim ring LEDs are ON.
  - c. Turn ignition switch ON. Trim ring LEDs are ON.

### WARNING

After installing seat, pull upward on seat to be sure it is locked in position. While riding, a loose seat can shift causing loss of control, which could result in death or serious injury. (00070b)

3. See the service manual to install the seat.

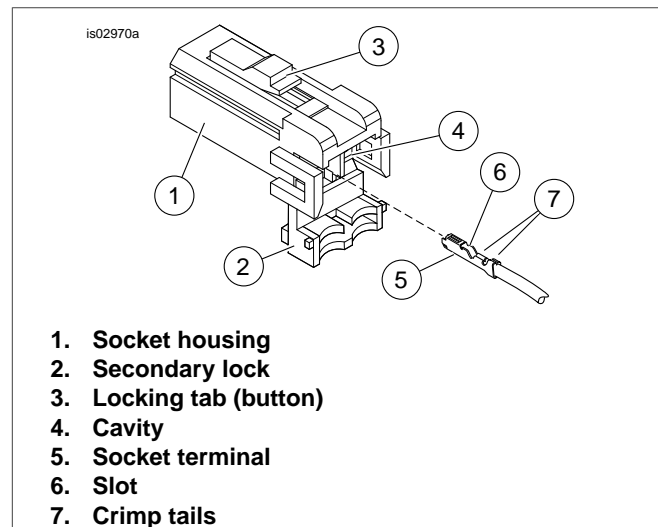

Figure 1. Socket Terminal Installation

## SERVICE PARTS

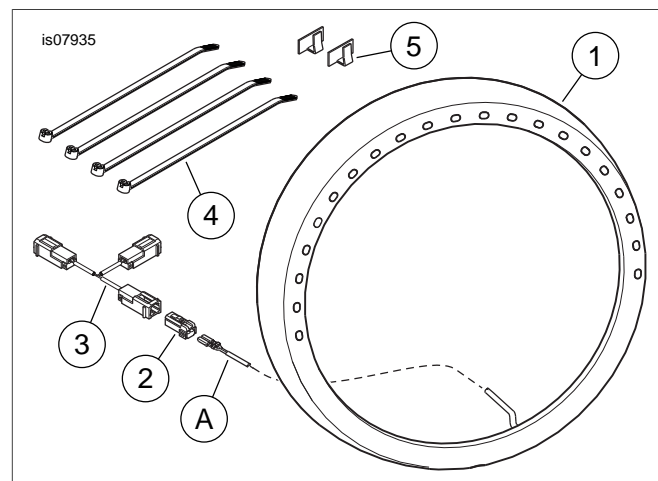

Figure 2. Service Parts, Electra Glo Trim Ring Kits for Seven Inch Headlamp

Table 1. Service Parts

Item	Description (Quantity)	Part Number
1	Electra Glo trim ring, 7 in	Not sold separately
2	Two-way socket housing	73152-96BK
3	Wire harness, headlamp trim ring	69200602
4	Cable strap (4)	10065
5	Clip, adhesive back (2)	10102
<b>Item mentioned in text.</b>		
A	Trim ring wiring and socket terminals	