

INCO



OPERATING MANUAL

CO₂ incubators

INCO 108 INCO 108 med

INCO 153 INCO 153 med

INCO 246 INCO 246 med

Manufacturer and customer service

MEMMERT GmbH + Co. KG
Postfach 17 20
D-91107 Schwabach
Äußere Rittersbacherstr. 38
D-91126 Schwabach
Germany

Fon: +49 (0) 09122 / 925-0
Fax: +49 (0) 09122 / 14585
E-Mail: sales@memmert.com
Internet: www.memmert.com

Customer service:

Fon: +49 (0) 09122/925-128
and: +49 (0) 09122/925-126
E-Mail: service@memmert.com

For service enquiries, please always specify the appliance number on the nameplate (see page 15).

© 2014 Memmert GmbH + Co. KG

Edition 11/2014

Subject to modifications

About this manual

Purpose and target group

This manual describes the setup, function, operation and maintenance of CO₂ incubators of the types INCO and INCOmed with a chamber volume of 108, 153 and 246 litres. In this manual, the term INCO is used for INCO as well as INCOmed for the purpose of simplification. Distinctions are explicitly pointed out.

This manual is intended for use by the trained staff of the operator in charge of operating and/or maintaining the incubator. If you are asked to work on the incubator, you should read this manual carefully before starting work on the unit. Familiarise yourself with the safety regulations. Only perform the work that is described in this manual. If there is something you don't understand, or certain information is missing, ask your superior or get in touch with the manufacturer. Do not do anything without authorisation.

Contents

The INCO incubator is available with different fittings: as a basic model, and with six different additional modules. The technical fittings and functional range of the basic model and the individual additional modules are described from page 11.

If specific equipment features or functions are available only with one of the additional modules, this is pointed out in the relevant sections in this manual.

Due to individual fittings, depictions in this manual may be different from the actual appearance.

Other documents that you must read:

▶ for service and repair work (see page 59) – a separate service manual

Storage and Forwarding

This instruction manual belongs with the incubator and should always be stored so that those who work on the incubator have access to it. It is the responsibility of the operator to ensure that persons who work on or who will work on the incubator are informed as to the whereabouts of this instruction manual. We recommend that it is always stored in a protected location close to the incubator. Make sure that the instruction manual is not damaged by heat or damp. If the incubator is sold on or transported and then set up again at a different location, this instruction manual must go with it.

Content

1. Safety regulations	6
1.1 Terms and icons used	6
1.2 Product safety and dangers	7
1.3 Requirements of the operating personnel	8
1.4 Responsibility of the owner	8
1.5 Changes and conversions	8
1.6 Behaviour in case of malfunctions and irregularities	8
1.7 What to do in case of accidents	9
1.8 Switching off incubator in an emergency	9
2. Design and Function	10
2.1 Design	10
2.2 Function	11
2.3 Optional extras	11
2.4 Material	13
2.5 Electrical equipment	13
2.6 Connections	13
2.7 Intended use	14
2.8 EC Declaration of Conformity	15
2.9 Designation (nameplate)	15
2.10 Technical data	16
2.11 Ambient conditions	18
2.12 Accessories included	18
3. Delivery, Transport and Setting Up	19
3.1 Safety regulations	19
3.2 Transport	19
3.3 Delivery	19
3.4 Setup	20
4. Putting into Operation	22
4.1 Checks	22
4.2 Connecting	22
4.3 Oxygen calibration	24
5. Operation and control	25
5.1 Operating personnel	25
5.2 Opening the door	25
5.3 Loading the incubator	25
5.4 Inserting water tray(s)	26
5.5 Connect gas supply	26
5.6 Switch on appliance	26
5.7 Basic operation	27
5.8 Setting parameters	27
5.9 Operating modes	28
5.10 Setting the operating mode	28
5.11 During operation	34
5.12 Ending operation	37
6. Warning messages and malfunctions	38
6.1 Warning messages	38
6.2 System/appliance errors	39
6.3 Power failure	42

7. Advanced functions	43
7.1 Printer	43
7.2 Basic appliance settings (Setup).....	43
7.3 Temperature monitoring	45
7.4 Sterilisation chipcard	49
7.5 User ID card (optionally available as an accessory)	50
7.6 Calibration	50
7.7 Communication interfaces	55
7.8 Log memory	58
8. Maintenance and Servicing	59
8.1 Cleaning.....	59
8.2 Regular maintenance.....	59
8.3 Adjusting door.....	60
8.4 Repairs and Service.....	60
9. Storage and Disposal	61
9.1 Storage	61
9.2 Disposal	61
Index	62

1. Safety regulations

1.1 Terms and icons used

















In this manual, certain common terms and icons are used to warn you of dangers or to give you notes that are important in avoiding injury or damage. Observe and follow these notes and regulations to avoid accidents and damage. These terms and icons are explained below.

1.1.1 Terms used

"Warning" is always used whenever you or somebody else could be injured if you do not observe the accompanying safety regulation.

"Caution" is used for information that is important for avoiding damage.

1.1.2 Icons used

Prohibited sign (forbidding an action)					
	Do not tilt appliance		Do not lift appliance		
Warning icons (warning of a danger)					
	Danger of electrical shock		Explosive atmosphere		Danger of frost-bite/cold burns
	Warning of gas bottles		heat/hot surfaces		Gas
Regulation signs (stipulate an action)					
	Disconnect the mains plug		Wear gloves		Wear safety shoes
	Observe information in separate manual		Two or more persons required		
Other icons					
	Information on first aid		First Aid: Rinse eyes out		Important or useful additional information

1.2 Product safety and dangers

Incubators of the INCO type are technically well-developed, manufactured using high-quality materials and tested for many hours in the factory. They contain the latest technology and comply with recognised technical safety regulations. But there are still dangers involved, even when the appliance is used as intended. These dangers are described below.

**Warning!**

After removing covers, live parts may be exposed. You may receive an electric shock if you touch these parts. Disconnect the mains plug before removing any covers. Any work inside the unit may only be performed by qualified electricians.

**Warning!**

When loading the chamber with an unsuitable load, poisonous or explosive vapours or gases may be produced. This could cause the chamber to explode, and people could be badly injured or poisoned. The chamber may only be loaded with materials/test objects which do not form any poisonous or explosive vapours when heated up (see also Chapter 2.7 Intended use on page 14).

**Warning!**

Danger of suffocation. In high concentrations, CO₂ and N₂ can have a suffocating effect. In normal operation, the incubator gives off small amounts of CO₂ and – if equipped with the O₂ module – N₂ to its environment. You should therefore ensure that the room in which it is installed is properly ventilated. If a gas bottle is not connected, or is empty, always close the stop valve or pressure reducer on the bottle.

**Warning!**

High concentrations of CO₂ can cause cold burns or frostbite. Avoid contact with CO₂ gas to the eyes and skin.

**Warning!**

CO₂ gas bottles may burst or explode at high temperature. Do not use naked flames in the vicinity of the gas bottles. Store gas bottles at lower than 50 °C in a well-ventilated location. Prevent water from penetrating, as well as backflow into the gas bottles. It is essential that you read the safety notes and regulations of the gas suppliers.

CO₂ and N₂ are not dangerous substances in terms of the German Ordinance on Hazardous Substances (GefStoffV). You should nevertheless familiarise yourself with the applicable safety regulations prior to handling such gas bottles.

1.3 Requirements of the operating personnel

The incubator may only be operated and maintained by persons who are of legal age, and who have received instructions for the incubator. Personnel who are to be trained, instructed or who are undergoing general training may only be active on the incubator under the continuous supervision of an experienced person.

The incubator may only be transported by persons (fork-lift truck, manual pallet jack), who are trained for this work and who know the corresponding safety regulations.

Repairs may only be performed by qualified electricians. In this case the regulations in the separate service manual must be observed.

1.4 Responsibility of the owner

The owner of the incubator

- ▶ is responsible for the flawless condition of the incubator and for the incubator being operated in accordance with its intended use (see page 14);
- ▶ is responsible for ensuring that persons who are to operate or service the incubator are qualified to do this, have received instructions about the incubator and are familiar with this operating manual;
- ▶ must know about the applicable regulations, requirements and work protection regulations, and train staff accordingly;
- ▶ is responsible for ensuring that unauthorised persons have no access to the incubator;
- ▶ is responsible for ensuring that the maintenance plan is adhered to and that maintenance and repair work is properly carried out (see page 59);
- ▶ ensures, for example through corresponding instructions and inspections, that the incubator and its surroundings are kept clean and tidy;
- ▶ is responsible for ensuring that personal protective clothing is worn by operating personnel, e.g. work clothes, safety shoes, protective gloves.

1.5 Changes and conversions

No independent conversions or alterations may be made to the incubator. No parts may be added or inserted which have not been approved by the manufacturer.

Independent conversions or alterations result in the EC declaration of conformity (see page 15) losing its validity, and the incubator may no longer be operated.

The manufacturer is not liable for any damage, danger or injuries that result from independent conversions or alterations, or from non-observation of the regulations in this manual.

1.6 Behaviour in case of malfunctions and irregularities

The incubator may only be used when in a flawless condition. If you as the operator notice irregularities, malfunctions or damage, immediately put the incubator out of service (see Chapter 1.8) and inform your superiors.



You can find information on eliminating malfunctions from page 38.

1.7 What to do in case of accidents



1. Keep calm. Act resolutely and with consideration. Pay attention to your own safety.
2. Switch off the incubator and close the valves on the gas bottle.
3. Call a doctor.
4. Initiate first aid measures. If available: Call a trained first aid helper.

In case of contact with CO₂ to the eyes and skin:



Rinse eyes out with water for at least 15 minutes. With cold burns, rinse with water for at least 15 minutes. Cover over in a sterile manner. Call a doctor.

Inhaling CO₂ or N₂:

High concentrations can cause suffocation. Symptoms may include a loss of mobility and consciousness. The victim is not aware of suffocating.

Low concentrations of CO₂ can cause accelerated breathing and headaches.

Anyone affected should breathe fresh air, using a breathing device independent of recirculating air. Keep the person warm and calm. Call a doctor. In case of respiratory arrest, use artificial respiration.

If gas is escaping:

Leave the room immediately, warn others and ventilate the room. If you re-enter the room, use an autonomous breathing device (independent of ambient air) if it has not been established that the atmosphere is harmless.

1.8 Switching off incubator in an emergency

- ▶ Push main switch on front side of appliance (Fig. 1).
- ▶ Close the valves on the gas bottle.

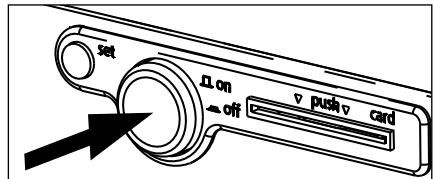

Fig. 1 Switch off incubator by pressing the main switch

2. Design and Function

2.1 Design



Fig. 2 Design of INCO incubators

- | | |
|-----------------------------------------------------|------------------------------------------|
| 1 Controller/control panel (see page 27) | 10 Sliding shelf |
| 2 Set key | 11 Door seal |
| 3 Push/turn control | 12 Ventilator/inlet opening |
| 4 Connections on the rear of the oven (see page 13) | 13 Heating ribs |
| 5 Heating ribs (see page 11) | 14 Adjustable feet |
| 6 Pt100 temperature sensors | 15 Nameplate (beneath door, see page 15) |
| 7 Humidity sensor | 16 Door knob (see page 25) |
| 8 Glass door | 17 Door |
| 9 Chamber seal | 18 Chip card reader |

2.2 Function

The air in the incubator is heated up by an all-round heater with a large surface (Fig. 3, No. 1). The CO₂ and/or N₂ gas is introduced into the working chamber via a sterile filter. Because CO₂ has a much higher specific weight than air, the gas is let into the working chamber above the interior fan (2). The turbulence-free interior ventilation (3) ensures a uniform distribution of the gases, creating a homogenous atmosphere.

In the basic version, humidification takes place by means of water trays (4). To avoid uncontrolled condensation, dosed fresh air is piped into the interior. If the appliance is equipped with a humidity module, humidification takes place via a hot-air generator, which allows water to evaporate at a set rate. The sterile hot air is let into the interior above the fan and is mixed with the air current (5).

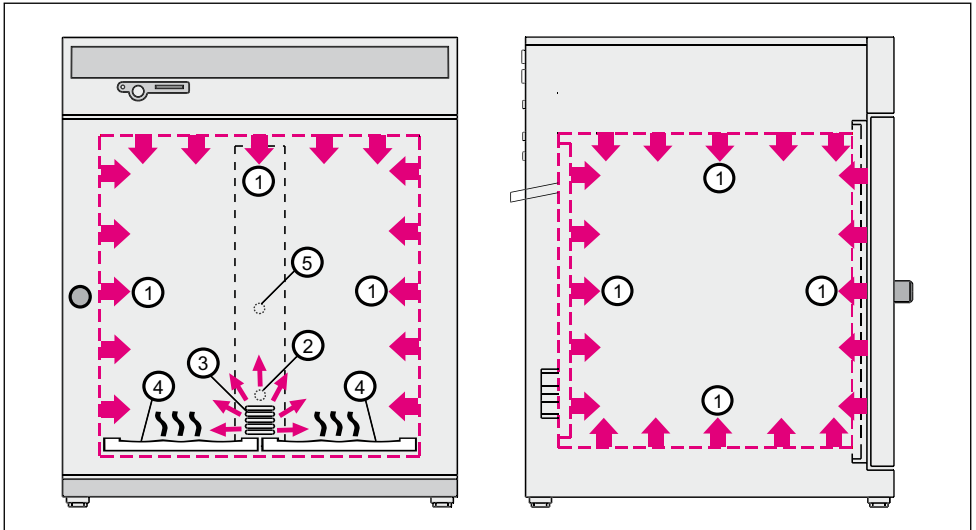

Fig. 3 How INCO incubators work

2.3 Optional extras

2.3.1 Basic equipment

- ▶ Electronic fuzzy-supported PID process controller with pulse width modulation and permanent performance adjustments and time-saving self-diagnosis system to quickly locate errors (see page 39)
- ▶ All-round heater with larger surface area, with additional thermal conduction layer (see Fig. 3)
- ▶ Capacitive humidity sensor
- ▶ Humidity control (fresh air via sterile filter) ensures that setpoint humidity is quickly reached and guarantees short recovery times, while avoiding condensation formation
- ▶ Homogenous atmosphere and temperature distribution through encapsulated, turbulence-free ventilation system
- ▶ STERICard for fully automatic sterilisation process control for hot air sterilisation of appliance, including sensors and fan rotor (see page 49)

- ▶ Digitalised electronic CO₂ control with automatic zero position, NDIR measuring system with self-diagnosis system and acoustic error display, air pressure compensation
- ▶ Language settings (see page 44)
- ▶ Alphanumeric text display
- ▶ Integrated week time switch with grup function (e.g. each working day) (see page 31)
- ▶ Retracting push-turn control for simple operation of appliance (see page 26)
- ▶ Two separate Pt100 temperature sensors DIN Class A in a 4-wire circuit for control and monitoring
- ▶ Digital monitoring control for overtemperature, undertemperature and automatic setpoint following (ASF) (see page 48)
- ▶ Mechanical temperature limiter (TB protection class 1, see page 45)
- ▶ Monitoring relay to switch off heater in case of error
- ▶ Optical alarm display
- ▶ Acoustic signal messages if temperature or CO₂ limits are crossed, when door is open and if gas bottle is empty (see page 38)
- ▶ Calibration of temperature, humidity, CO₂ and O₂ possible on the device without a separate PC (see from page 50)

2.3.2 Optionally available additional modules

Comfort module:

- ▶ Two gas connections with quick release connectors (see page 13)
- ▶ Automatic switch-over of gas bottles

Hygiene module

- ▶ Electro-polished, seamless laser-welded chamber

Communication module

- ▶ Logging option of temperature, CO₂ and relative humidity via computer/laptop
- ▶ Internal log memory with 1024 kB as ring memory for all setpoint and actual values, errors and settings in real time and with date, logging approx. 3 months at 1 minute storage interval (see page 58)
- ▶ Parallel printer port (PCL3-compatible) for printing out log data (see page 13 and page 43)
- ▶ optionally USB, Ethernet, RS-232 or RS-485 interface (see from page 55)

CO₂ module

- ▶ Extended adjustment range from 0 to 20 %
- ▶ 3-point calibration (5 %, 10 %, 15 % CO₂)

O₂ module

- ▶ Control of oxygen concentration through the introduction of nitrogen (N₂); adjustment range 1 % to 20 % O₂ (not in combination with Comfort or Premium module)

Premium module

- ▶ Includes comfort, hygiene, communication and CO₂ modules

Humidity module

- ▶ Active microprocessor humidification and dehumidification control (40-97 % rh)

2.4 Material

For the outer housing, MEMMERT uses stainless steel (W.St.No. 1.4016), and for the interior, stainless steel (W.St.No. 1.4301), which stands out through its high stability, optimal hygienic properties and corrosion-resistance towards many (but not all!) chemical compounds (caution for example with chlorine compounds). The chamber load for the appliance must be carefully checked with respect to chemical compatibility with the materials mentioned.

A material resistance table can be requested from the manufacturer.

2.5 Electrical equipment

- ▶ Operating voltage: See nameplate (page 15), 50/60 Hz
- ▶ Current consumption: See nameplate (page 15)
- ▶ Protection class 1, i.e. operating insulation with safety earth terminal in accordance with EN 61010
- ▶ Protection type IP 20 acc. to EN 60 529
- ▶ Interference-suppressed acc. to EN 55011 class B
- ▶ Appliance fuse: Fusible link 250 V/15 A quick-blow
- ▶ The temperature controller is protected with a miniature fuse 100 mA (200 mA at 115 V)
- ▶ For models with a humidity model the CO₂ controller is protected with a 6.3 A miniature fuse

2.6 Connections

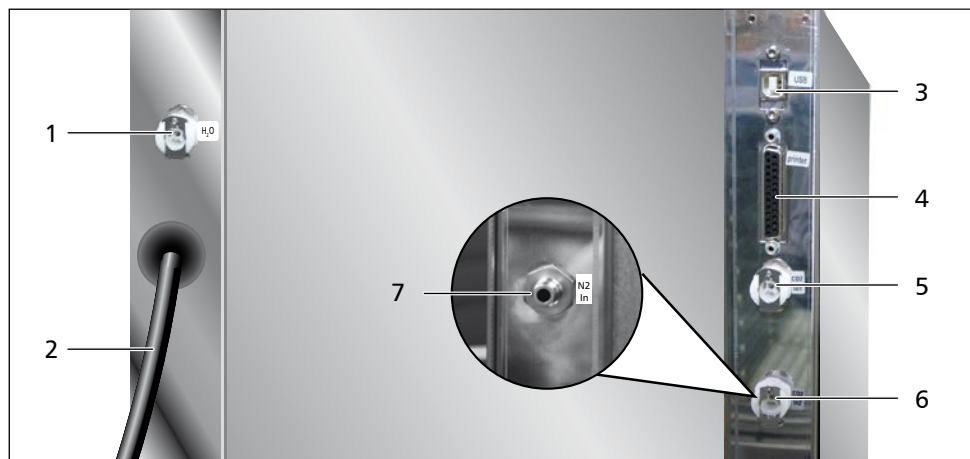

Fig. 4 Connections on rear of appliance

- 1 Water connection (only for model with humidity module)
- 2 Mains lead
- 3 USB connection (only for models with communication or premium modules; alternatively Ethernet, RS-232 or RS-485 connection) (details from page 55)
- 4 Printer connection (only for models with communication or premium modules) (see page 43)
- 5 CO₂ connection to main gas bottle
- 6 CO₂ connection to reserve gas bottle (only for models with CO₂ or premium modules)
- 7 N₂ connection (quick-release connector, only if equipped with O₂ module)

2.6.1 Electrical connection

Observe the country-specific regulations when making connections (e. g. in Germany DIN VDE 0100 with residual current device).

This appliance is intended for operation on an electrical power system with a system impedance Z_{max} at the point of transfer (service line) of a maximum of 0.292 ohm. The operator must ensure that the incubator is operated only on an electrical power system that meets these requirements. If necessary, you can ask your local energy supply company what the system impedance is.

2.6.2 Connection of external appliances

Only appliances may be connected externally (depending on the model, USB, RS 232, RS 485, Ethernet, printer) whose interfaces comply with the requirements for safety extra-low voltage (e.g. PC).

2.6.3 Gas connection

The oven can be connected with the supplied compressed air hose via a pressure regulator with gas bottle monitor (DIN 8546) to a CO₂ compressed gas bottle or directly to a central CO₂ gas supply.

For models with the CO₂ or premium modules, two gas bottles with quick release connectors can be connected. If equipped with the O₂ module, an N₂ gas bottle can be connected instead of a second CO₂ gas bottle (Fig. 4).

The pre-pressure must not exceed 1.2 bar. A value between 0.8 and 1 bar is considered to be an ideal value.

2.6.4 Water connection

For models with a humidity module, the incubator can be connected with the supplied hose to the also supplied water supply tank.

2.7 Intended use

INCO incubators may only be used for incubating cell cultures or similar. Any other use is improper, and may result in hazards and damage.

The incubators are not explosion-proof (they do not comply with workplace health & safety regulation VBG 24). The chambers may only be loaded with materials and substances which cannot produce any toxic or explosive vapours at temperature ranges up to 50 °C, and which themselves cannot explode, burst or ignite.

The incubators may not be used for drying, vaporising and branding paints or similar materials, the solvents of which could form an explosive mixture when combined with air. If there is any doubt as to the composition of materials, they must not be loaded into the incubator. Potentially explosive gas-air mixtures must not be produced, either in the interior of the chamber or in the direct vicinity of the appliance.

The incubator may not be used for sterilisation purposes. It is not a steriliser with respect to the Law on Medical Devices.

Only gas bottles with a pressure regulator may be connected to the gas connections of the oven. Introducing other gases or materials than CO₂ or N₂ is not permitted.

2.7.1 Intended use of the INCOmed

For INCOmed incubators, which are subject to the 93/42/EEC guideline (Council Directive on the approximation of the laws of the Member States relating to medical devices), the intended use is defined as follows:

The CO2 incubator INCO med is intended for the creation and maintenance of constant environmental conditions for application in the field of in vitro fertilisation (IVF), especially for the incubation of oocytes, spermatozoa and zygotes in special culture dishes for IVF application as well as for gene expression and the biosynthesis of RNA and proteins.

2.8 EC Declaration of Conformity

You can download the EC declaration of conformity of the appliance online:

English: <http://www.memmert.com/en/service/downloads/ce-statement/>

German: <http://www.memmert.com/de/service/downloads/eg-konformitaetserklaerung/>

2.9 Designation (nameplate)

The nameplate (Fig. 5) provides information about the appliance model, manufacturer and technical data. It is attached to the front of the appliance, on the right beneath the door (see page 10).

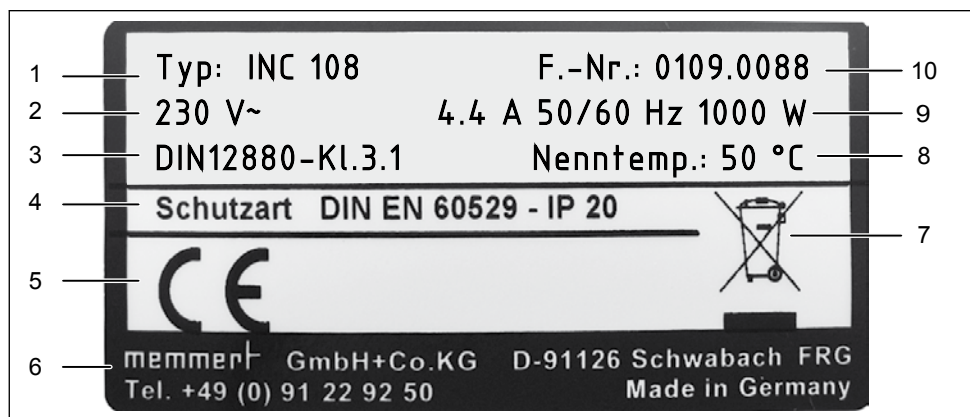

Fig. 5 Nameplate

- 1 Type designation
- 2 Operating voltage
- 3 Applied standard
- 4 Protection type
- 5 CE conformity

- 6 Address of manufacturer
- 7 Disposal note
- 8 Temperature range
- 9 Connection / performance values
- 10 Factory number

2.10 Technical data

Model <i>* See Fig. 6 on page 17.</i>	108	153	246
Chamber width A* [mm]	560	480	640
Chamber height B* [mm]	480	640	640
Chamber depth C* [mm]	400	500	600
Appliance width D* [mm]	710	630	790
Appliance height E* (varies due to adjustable feet) [mm]	778	920	938
Appliance depth F* (including door handle) [mm]	590	690	790
Chamber volume [litres]	108	153	246
Weight [kg]	70	90	110
Performance [W]	1000	1500	2000
Max. number of sliding shelves half size / full size	-/4	-/6	2 x 6/6
Max. load per sliding shelf [kg]	15	15	15
Max. load per appliance [kg]	40	40	60
Temperature	Temperature recording by means of Pt100 in a 4-wire circuit Adjustment range: Normal mode: 20 °C to 50 °C Sterilisation mode: 160 °C (4 hours) via STERICard Adjustment precision: 0.1 °C Control range: from 8 °C above room temperature to 50 °C Variation (time): max. ±0,1 °C at 37 °C Variation (spatial): max. ±0.3 °C at 37 °C		
Humidity	The relative humidity in the chamber is measured by a capacitive humidity sensor and displayed digitally in percent. The measurement precision of the humidity sensor is 1 % rh <ul style="list-style-type: none"> ▶ Adjustment range: 88 to 97 % rh (for models with humidity module 40 to 97 % rh) ▶ Adjustment precision: 1 % rh ▶ Display range: 10 to 98 % rh ▶ Variation (time): max. ±1 % rh 		

Model * See Fig. 6 on page 17.	108	153	246
CO ₂	<p>The CO₂ content is determined through an NDIR measuring system, controlled constantly by a microprocessor and displayed digitally in percent</p> <ul style="list-style-type: none"> ▶ Adjustment range: 0 to 10 % (for models with CO₂ or premium modules 0 to 20 %) ▶ Adjustment precision: 0.1 % ▶ Variation (time): max. ±0.1 % rh ▶ Variation (spatial): max. ±0.3 % 		
O ₂ (only if equipped with O ₂ module)	<p>The O₂ content is determined with a long-lasting, maintenance-free zirconium dioxide sensor, constantly controlled by a microprocessor and displayed digitally in percent</p> <ul style="list-style-type: none"> ▶ Adjustment range: 1 to 20 % ▶ Adjustment precision: 0.1 % ▶ Variation (time): max. ±0.1 % ▶ Variation (spatial): max. ±0.3 % 		

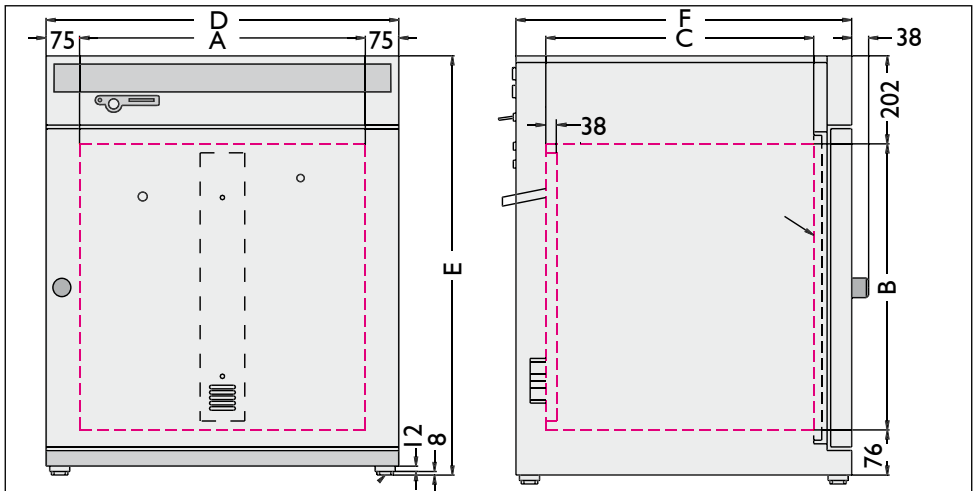

Fig. 6 Dimensions of INCO incubators

2.11 Ambient conditions

- ▶ The incubator may only be used in enclosed rooms and under the following environmental conditions:
Ambient temperature: 5 °C to 35 °C
Humidity: max. 80 % not condensing
Degree of pollution: 2
Altitude of installation max. 3,000 m above sea level
- ▶ The incubator may not be used in areas where there is a risk of explosions. The ambient air must not contain any explosive dusts, gases, vapours or gas-air mixtures. The incubator is not explosion-proof.
- ▶ Heavy dust production or aggressive vapours in the vicinity of the appliance could lead to sedimentation in the chamber interior and as a consequence, could result in short circuits or damage to electrical parts. For this reason, sufficient measures should be taken to prevent large clouds of dust or aggressive vapours from developing.

2.12 Accessories included

For incubators with basic fittings:

- ▶ Two (INCO 108) or three (INCO 153 and 246) sliding shelves
- ▶ Gas pressure hose
- ▶ Water tray (one for INCO 108 and 153 incubators, two for INCO 246 incubators)
- ▶ Sterilisation chipcard

Additionally, for models with humidity module:

- ▶ Water supply tank and connection hose

Additionally, for models with CO₂ or premium module:

- ▶ Second gas pressure hose with quick-release connector

Additionally, for models with O₂ module:

- ▶ Second gas pressure hose with quick-release connector

3. Delivery, Transport and Setting Up

3.1 Safety regulations

**Warning!**

You may injure your hands or feet when transporting and installing the incubator. You should wear protective gloves and work shoes.

**Warning!**

Because of the weight of the incubator, you could injure yourself if you try to lift it on your own.

If possible, only transport the incubator with a fork-lift truck or manual pallet jack. The incubator may only be moved using a means of transport by persons who have the required qualification for this (e.g. fork-lift truck licence). This incubator may not be transported with a crane.



If the incubator has to be carried, at least two people are required for models 108 and 153, and at least four people for model 246.

**Warning!**

The incubator could fall over and seriously injure you. Never tilt the incubator and transport it only in an upright position.

3.2 Transport

The incubator can be transported in three ways:

- ▶ with a fork-lift truck; move the forks of the truck entirely under the incubator
- ▶ on the manual pallet jack.
- ▶ by carrying; to do this, at least two people are required for models 108 and 153, and four people for model 246. Read the weight information detailed on page 16.

3.3 Delivery

The incubator is delivered in cardboard packaging on a cardboard pallet.

3.3.1 Unpacking

1. Remove cardboard packaging or cut open carefully along an edge.
2. Lift up incubator from pallet and put down on the appliance feet.

3.3.2 Checking for completeness and transport damage

- ▶ Check the delivery note to ensure that the delivery is complete.
- ▶ Check the inside and outside of the incubator for damage.

If you notice deviations from the delivery note, damage or irregularities, do not put the incubator into operation, but inform the haulage company and the manufacturer.

3.3.3 Disposing of packaging material

Dispose of the packaging material (cardboard) in accordance with the effective legal disposal regulations for cardboard packaging in your country.

3.3.4 Storage after delivery

If the incubator is initially to be stored after delivery: Read the storage conditions from page 61.

3.4 Setup

The incubator can be placed either on the ground or on a table (work surface). When doing this, ensure that the appliance is positioned exactly horizontally. The installation site must be level and able to reliably carry the weight of the incubator (see page 16). Do not place the appliance on an inflammable surface.

A power connection must be available at the installation site in accordance with the connection data on the nameplate (see page 15).

The distance between the wall and the rear of the chamber must be at least 15 cm. The clearance from the ceiling must not be less than 20 cm and the side clearance from the wall not less than 8 cm (Fig. 7). Sufficient air circulation in the vicinity of the chamber must be guaranteed at all times.

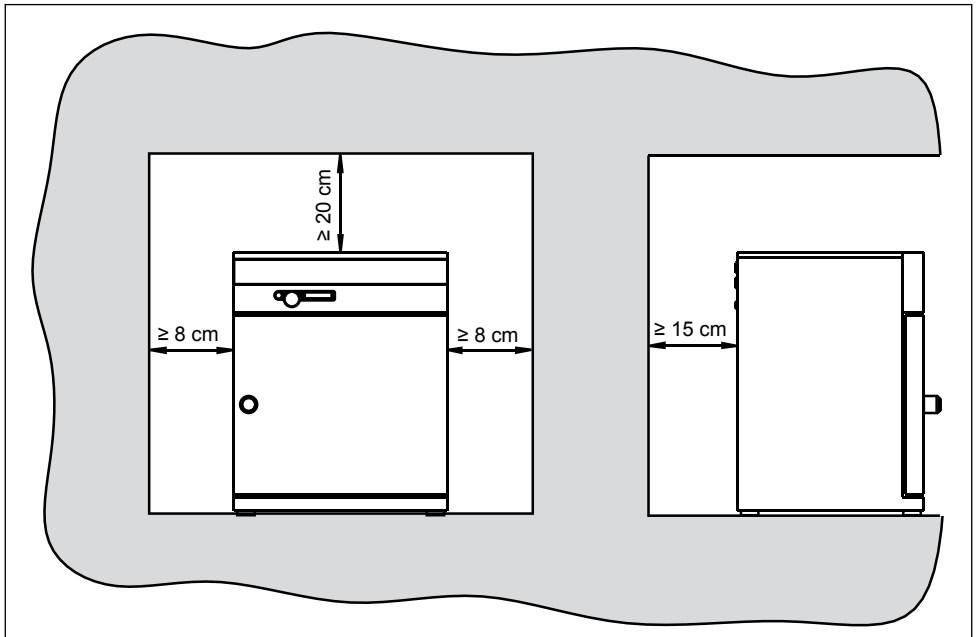

Fig. 7 Minimum clearance from walls and ceiling

3.4.1 Base (accessory)

The incubator can be placed on a base (Fig. 8).

3.4.2 Stacking frame (accessory)

Two appliances of the same model size can be placed on top of one another. To do this, foot alignment provisions must be attached to the lower oven (Fig. 9):

1. Remove the housing cover from the lower oven.
2. Insert drilling template (supplied with the foot alignments) into the overturned lid.
3. Mark drilling points and drill with a 4.2 mm diameter drill bit.
4. Screw the foot alignment provisions to the top of the lid with the screws and nuts supplied.
5. Put the covers back on.

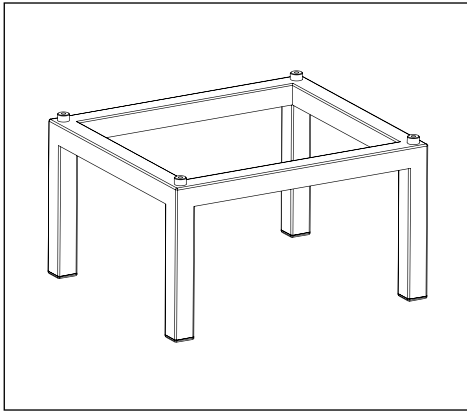

Fig. 8 Base

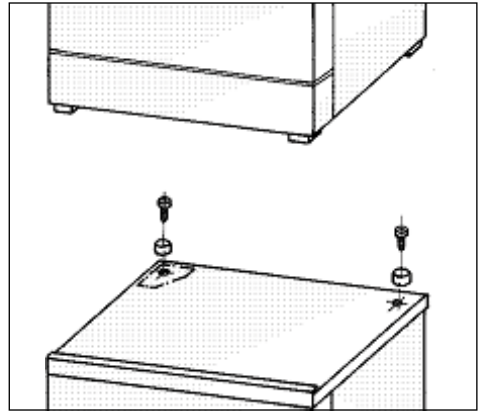

Fig. 9 Assembly of the foot alignment provisions when two incubators are placed on top of one another

4. Putting into Operation

4.1 Checks

4.1.1 Checking the temperature sensor

Especially strong vibrations during transport could result in the temperature sensors being moved in their holders in the working chamber.

Check the temperature sensor for its correct positioning and if necessary adjust its position in the holder (Fig. 10).

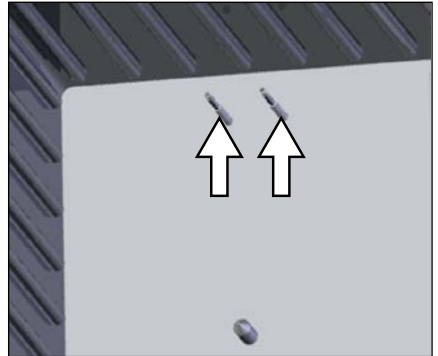

Fig. 10 Temperature sensor

4.1.2 Check the door and adjust if necessary

See page 60.

4.2 Connecting

4.2.1 Power supply



Caution:

Observe the country-specific regulations when making connections (e. g. in Germany DIN VDE 0100 with residual current device / RCD). Observe the connection and power ratings (see nameplate).

The incubator is intended for operation on an electrical power system with a system impedance Z_{max} at the point of transfer (service line) of a maximum of 0.292 ohms. The operator must ensure that the incubator is operated only on an electrical power system that meets these requirements. If necessary, you can ask your local energy supply company what the system impedance is.

Connect power cable (see Fig. 4 on page 13).

4.2.2 External devices

(only for models with communication or premium modules)

Only appliances whose interfaces comply with the requirements for safety extra-low voltage (e.g. PC, laptop, printer) may be connected to the connections on the rear of the incubator (see Fig. 4 on page 13). Which devices may be connected depends on the chosen model / module variant (Communication interfaces described in detail from page 55).

4.2.3 Water connection

(only for models with humidity module)

For steam creation, use only demineralised water (aqua dem) in accordance with VDE 0510/DIN EN 50272; regulations must be strictly adhered to (production conductivity $\geq 5 \leq 10 \mu S/cm$). Battery water in accordance with VDE 0510 is available in larger chemist's shops, super markets, hardware stores and in the wholesale trade. The standard VDE 0510/DIN EN 50272 has to be explicitly specified on the label.

Otherwise, possible calcification in the steam generators, steam piping and peristaltic pumps could affect the operability of the device.

The water used must have a pH value between 5 and 7 and be chlorine-free.

1. Fill up the supplied water supply tank (canister) with distilled water and place behind/ next to the incubator.
2. Attach the supplied hose the quick-release connections to the canister and the water supply "H₂O" on the rear of the appliance (see Fig. 4 on page 13).

4.2.4 Gas connection



Warning!

Danger of suffocation: In high concentrations, CO₂ and N₂ can have a suffocating effect. In normal operation, the incubator gives off small amounts of CO₂ and – if equipped with the O₂ module – N₂ to its environment. You should therefore ensure that the room in which it is installed is properly ventilated.



Warning!

High concentrations of CO₂ can cause cold burns or frostbite. Avoid contact with CO₂ gas to the eyes and skin.



Warning!

CO₂ gas bottles may burst or explode at high temperature. Do not use naked flames in the vicinity of the gas bottles. Store gas bottles at lower than 50 °C in a well-ventilated location. Prevent water from penetrating, as well as backflow into the gas bottles. It is essential that you read the safety notes and regulations of the gas suppliers.

For incubators with basic fittings:

Attach the supplied pressure hose to the gas bottle (pressure regulator) and to the "CO₂" connection on the rear of the appliance with two hose clamps (Fig. 11, see also page 13).

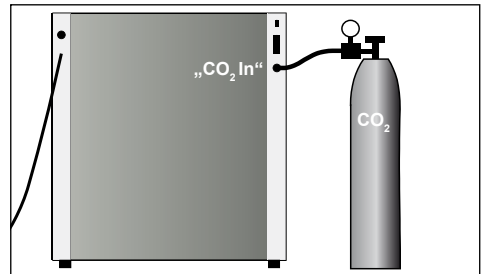

Fig. 11
Gas connection for incubators with basic fittings

For incubators with CO₂ or premium module:

Two gas bottles can be connected by simply pushing the supplied pressure hoses onto the "CO₂ In1" and "CO₂ In2" quick-release connections on the rear of the appliance (Fig. 12, see also page 13).

Connect the main gas bottle to "In1", a reserve gas bottle can be connected to "In2". Attach the pressure hose to the gas bottles (pressure regulator) with hose clamps.

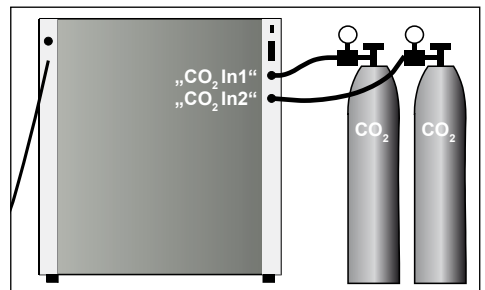

Fig. 12
Gas connection for incubators with CO₂ or Premium modules

For incubators with O₂ module:

- ▶ Attach the supplied CO₂ pressure hose to the CO₂ gas bottle (pressure reducer) and to the "CO₂ In" connection on the rear of the incubator with a hose clamp (Fig. 13, see also page 13).
- ▶ Attach (push on) the supplied N₂ pressure hose to the N₂ gas bottle (pressure reducer) and to the "N₂ In" connection on the rear of the incubator with a hose clamp.

4.3 Oxygen calibration

(only for models with O₂ module)

Perform an O₂ calibration before putting into operation (see page 54).

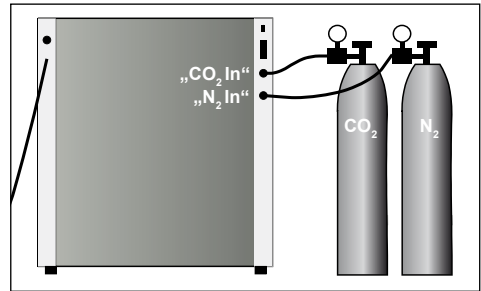

Fig. 13
Gas connection for incubators with O₂ module

5. Operation and control

5.1 Operating personnel

The incubator may only be operated by persons who are of legal age and have received instructions for the incubator. Personnel who are to be trained, instructed or who are undergoing general training may only be active on the incubator under the continuous supervision of an experienced person.

5.2 Opening the door

- ▶ To open the door, turn handle to the right (Fig. 14).
 - ▶ To close, turn door handle to the left.
- i** When the door is opened, the CO₂ supply is automatically interrupted. If the heated outer door is left open for any length of time, condensation may form on the glass door.

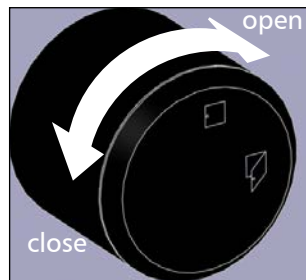

Fig. 14 Opening and closing the door

5.3 Loading the incubator



Warning!

When loading the chamber with an unsuitable load, poisonous or explosive vapours or gases may be produced. This could cause the chamber to explode, and people could be badly injured or poisoned. The chamber may only be loaded with materials/test objects which do not form any toxic or explosive vapours when heated up, and which cannot ignite. If there is any doubt as to the composition of materials, they must not be loaded into the incubator.



Caution:

i Check the chamber load for chemical compatibility with the materials of the incubator (see page 13), since considerable damage could otherwise occur to the chamber load, the appliance or the surroundings.

The incubators are not explosion-proof (they do not comply with workplace health & safety regulation VBG 24) and are therefore not suitable for drying, vaporising and branding paints or similar materials, the solvents of which could form an explosive mixture when combined with air. Potentially explosive gas-air mixtures must not be produced, either in the interior of the chamber or in the direct vicinity of the appliance.

Heavy dust production or aggressive vapours in the chamber or in the vicinity of the appliance could lead to sedimentation in the chamber interior and as a consequence, could result in short circuits or damage to electrical parts. For this reason, sufficient measures should be taken to prevent large clouds of dust or aggressive vapours from developing.

The chamber must not be loaded too tightly, so that proper air circulation in the working chamber is guaranteed. Do not place any of the chamber load on the floor, touching the side walls or right below the ceiling (heating ribs) of the working chamber. To guarantee an optimal air circulation, push in the sliding shelves so that the gaps between the door, sliding shelf and rear wall of the chamber are roughly the same size.

5.4 Inserting water tray(s)

(for appliances with basic fittings)

Fill the water tray with distilled water and push into the lowest slot (Fig. 15).

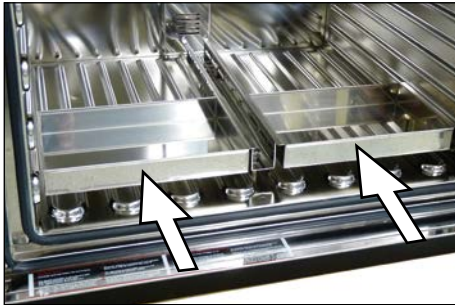

Fig. 15 Inserting water tray(s)

INCO model	Number of water trays	Filling level in cm for each tray approx.	Amount of water in ltr. for each tray approx.
108	1	1.5 to 2.5	1 to 1.5
153	1	1.5 to 2.5	1 to 1.5
246	2	1.5 to 2.5	1 to 1.5

5.5 Connect gas supply

1. Check that the gas bottle(s) is properly connected (see also page 13).
2. Open valve(s).

5.6 Switch on appliance

The incubator is switched on and off by pressing the main switch/ push-turn control on the front of the appliance.

- ▶ Switching on: press the main switch so that it comes out of the appliance (Fig. 16).
- ▶ Switching off: press the main switch so that it retracts back into the appliance (Fig. 17).

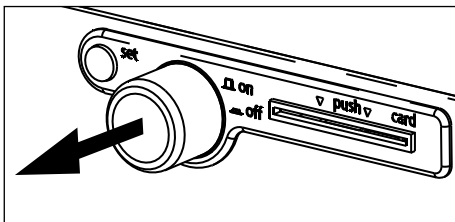

Fig. 16 Switching on incubator

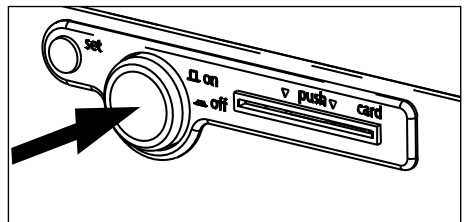

Fig. 17 Switching off incubator

5.7 Basic operation

The desired parameters are entered on the operating panel of the controller on the front of the appliance (Fig. 18). Basic settings, as well as those for time and printing, can also be made here. In addition, programmed and current parameters are displayed, as well as warning messages:

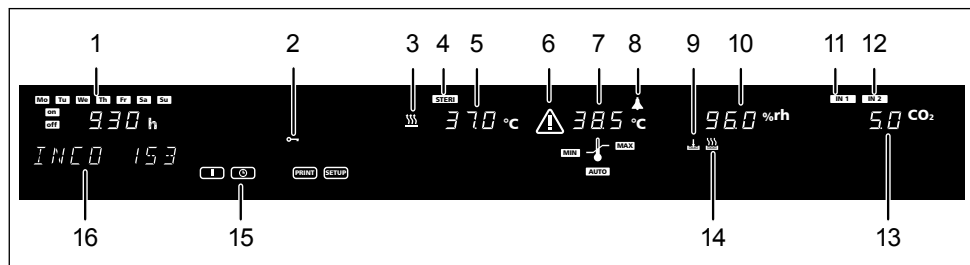
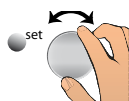
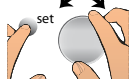

Fig. 18 Operating panel

- | | |
|-------------------------------------------------------------------------------------------------------------------------------------------------------------------------------------------------------------------------------------------------------------------------------------------------------------------------------------------------------------|-------------------------------------------------------------------------------------------------------------------------------------------------------------------------------------------------------------------------------------------------------------------------------------------------------------------------------------------------------------------------------------------------------------------------------------|
| <ul style="list-style-type: none"> 1 Time display 2 Display appliance locked with user-ID card (see page 50) 3 Display appliance is heating up 4 Sterilisation mode (see page 49) 5 Temperature display 6 Alarm display 7 Monitoring temperature display (see page 45) 8 Horn | <ul style="list-style-type: none"> 9 Warning water supply tank empty 10 Humidity display 11 Gas bottle 1 active 12 Gas bottle 2 active 13 CO₂ display 14 Display appliance is humidifying 15 Operating mode display (see page 28) 16 Text display/O₂ display (O₂ display only if equipped with O₂ module) |
|-------------------------------------------------------------------------------------------------------------------------------------------------------------------------------------------------------------------------------------------------------------------------------------------------------------------------------------------------------------|-------------------------------------------------------------------------------------------------------------------------------------------------------------------------------------------------------------------------------------------------------------------------------------------------------------------------------------------------------------------------------------------------------------------------------------|



All operating functions are selected by turning the push-turn control to the left or right...



...and adjusted by turning this with the SET key held down.

5.8 Setting parameters

In general, all setting actions on the operating panel described on the following pages are made in the same way:

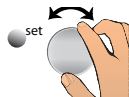

1. You select the desired parameter with the push-turn control (menu item, e. g. temperature); then all other parameters go dark and the selected one flashes.

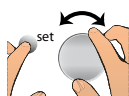

2. With the SET key held down, set the desired value (e. g. 37.0 °C) with the push-turn control.



3. Release the SET key, and the set value is saved. The display briefly shows the set value, flashing. The current temperature is displayed and the incubator begins to heat up to the set temperature.

Settings for other parameters are made in the same way.

i The control returns automatically to the main menu if the push-turn key or set key is not operated for approx. 30 seconds.

Setting the temperature (Quick adjustment):

1. Hold down the SET key and set the desired temperature setpoint with the push-turn control.
2. Release the SET key

The appliance flashes briefly, showing the temperature setpoint. Then the current temperature appears on the display and the controller begins to move to the set temperature.

5.9 Operating modes

INCO incubators can be operated in three ways (Fig. 19).

- ▶ Normal mode: The incubator runs in permanent operation at the temperature, humidity and CO₂ values set on the operating panel. Operation in this mode is described from page 29.
- ▶ Week time switch: The incubator runs at the set values only at certain times. Operation in this mode is described from page 31.
- ▶ Interface mode with PC/laptop (for models with communication or premium modules, see from page 55)

In addition, basic appliance settings can be made (SETUP, see page 43) and printouts can be made if the appliance is equipped with the communication or premium module (PRINT, see page 43).

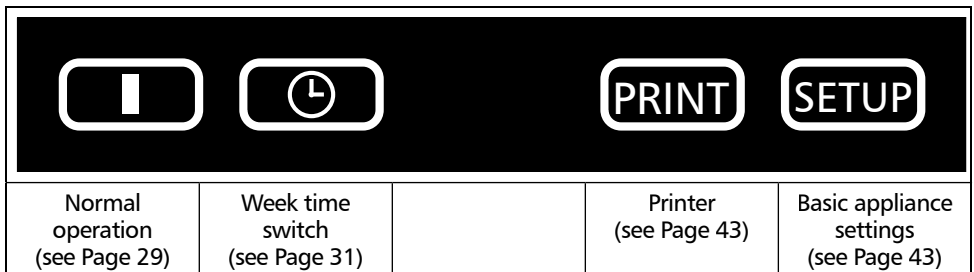

Fig. 19 Operating modes

5.10 Setting the operating mode

1. Hold SET key down for approx. three seconds, the selected operating mode then begins to flash.
2. Select the desired operating mode (normal mode, week time switch, programming mode, printer or basic appliance settings/setup) by turning control with SET held down.
3. Release the SET key, and the selected operating mode is saved.

5.10.1 Normal mode

The appliance runs in this operating mode in permanent operation. The desired setpoints for operating the chamber can be selected. The settings have an immediate effect on the functions of the appliance.

1. Load incubator (see page 25).
2. Switch on appliance. To do this, press the push-turn control on the operating panel so that it comes out of the appliance (see Fig. 16 on page 26).

3. Select the normal operating mode  with the push-turn control:



4. As described above, set the individual parameters with the push-turn control and the set key:

Temperature setpoint

Adjustment range: 20°C to 50°C



Temperature monitoring

Adjustment range:
MIN MAX AUTO
(see also page 45)

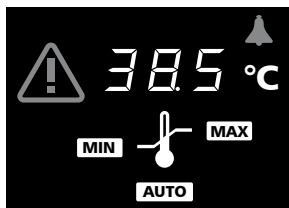

Humidity setpoint

Adjustment range:

- ▶ For incubators with basic fittings: 88 to 97 %rh
- ▶ For models with humidity module: 40 to 97 %rh



- High levels of air humidity in the interior can only be achieved without condensation if the interior is thoroughly heated. Please set the humidity only when the temperature in the interior has been stable for at least 30 minutes.

CO₂ setpoint

Adjustment range: 0 bis 10 %
(or models with CO₂ or premium modules 0 to 20 0 to 20 %)



O₂ setpoint

(only for models with O₂ module)

Adjustment range:
OFF, 1 to 20 %

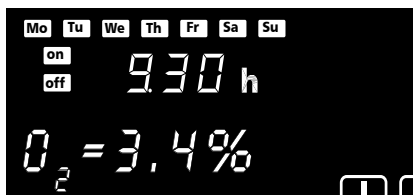

5.10.2 Settings example normal mode

With a 5% CO₂ content, a 3% oxygen content and a humidity of 96%, the appliance should heat up to 37°C. The monitoring function should respond at 38.5 °C (Fig. 20).

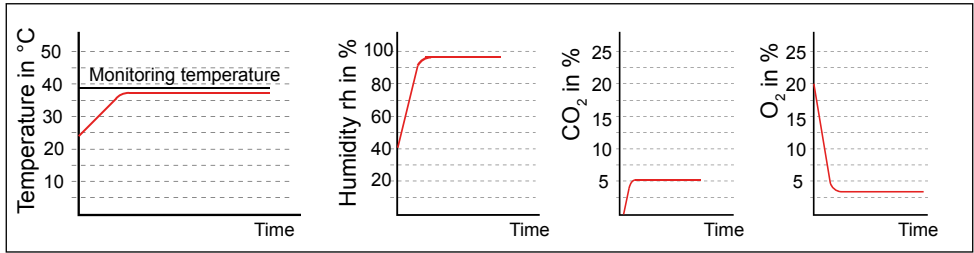



Fig. 20 Example for normal mode

1. Setting the normal operating mode:

Hold SET key down for approx. 3 seconds, the current operating mode then begins to flash.



Select the  operating mode with the push-turn control, while the SET key is held down. After you let go of the SET key, the control is in the normal operating mode.

2. Setting the temperature setpoint:

Hold down the SET key and set the desired temperature setpoint of 37.0 °C with the push-turn control.



Release the SET key, the appliance will briefly flash, showing the temperature setpoint. Then the current temperature





appears on the display and the controller begins to move to the set temperature of 37.0 °C.

▶ Heating up is indicated by the  icon.

3. Setting the monitoring temperature:

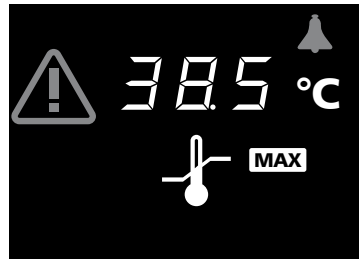
Turn the push-turn control to the right until the monitoring temperature and the MIN or MAX icon flashes. Hold down the SET key and with the push-turn control, set the overtemperature limit to 38.5 °C and the undertemperature limit to 36.0 °C. Turn the push-turn control to the right until the monitoring temperature and the AUTO icons flash. Hold down the SET key and set to  with the push-turn control.



 The tolerance band is set in the SETUP menu (see page 44).

4. Setting the humidity setpoint:

- High levels of air humidity in the interior can only be achieved without condensation if the interior is thoroughly heated. Please set the humidity only when the temperature in the interior has been stable for at least 30 minutes.



Turn the push-turn control to the right until the humidity display flashes. Hold down the SET key and set the desired humidity setpoint of 95.0 %rh with the push-turn control. After releasing the SET key, the humidity setpoint briefly flashes. The current humidity value appears on the display and the controller begins to move to the set value.

- The humidification process is indicated by the icon (only for models with humidity module).

5. Setting the CO₂ setpoint

Turn the push-turn control to the right until the CO₂ display flashes. Hold down the SET key and set the desired CO₂ setpoint of 5.0 % with the push-turn control. The appliance flashes briefly, showing the CO₂ setpoint. The current CO₂ actual value appears on the display and the controller begins to move to the set CO₂ setpoint.



- Depending on the bottle used, fumigation is displayed by the or icon.

6. Adjust the O₂ setpoint

(only for models with O₂ module)

Turn the push-turn control to the left until the O₂ display flashes. Hold down the set-key and set the desired O₂ setpoint of 3.0 % with the push-turn control. Release the set-key. The appliance flashes briefly, showing the O₂ setpoint. Then, the current O₂ actual value appears on the display and the controller begins to move to the set O₂ value.

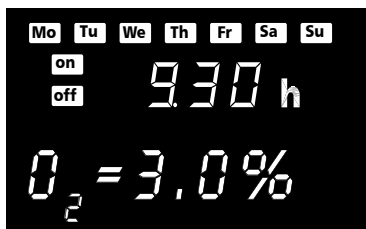

The incubator is now running in permanent operation with the set values.

5.10.3 Week time switch

In this operating mode, the appliance switches on and off automatically at the times programmed.



During the OFF phase of the week time switch, the appliance is in standby mode. The heating and cooling functions, along with the CO₂ and humidity supply are switched off here and the controller display shows the time, dimmed.

The sequence of the week time switch repeats itself each week.

In total, a maximum of 9 time blocks can be programmed, consisting of the switching on and switching off times.

Weekday

Adjustment range: Monday to Sunday



Day groups

Adjustment range: Working days Mo-Fr
Weekend Sat-Sun

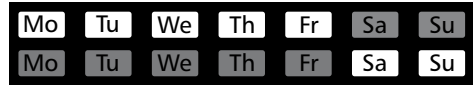

No switch on time: ----

Appliance not switched on on this day



Switch on time (on)

Adjustment range: 00:00 TO 23:59 HOURS



Switch off time (off)

One minute beyond the switch on time up to 24:00



By turning further to the right, parameters (temperature, humidity setpoints etc.) can be selected as in the normal operating mode.

- If no settings (temperature setpoint etc.) are made for the ON phase, the controller takes over the values from the normal operating mode.

For reasons of safety, you should always check that only one switch one time is programmed in the desired time blocks and days. By turning further to the right, parameters (temperature setpoint etc.) can be selected as in the normal operating mode.

If the controller is in standby mode or the week time switch is in the ON phase, the temperature setpoint can be directly accessed by briefly pressing the SET key. By turning the control to the right, you are returned to temperature monitoring, humidity and CO₂ setting. By turning to the left, you come back to the settings for the individual time blocks.

5.10.4 Settings example week time switch

From Mo-Fr (workdays group), the appliance should switch on at 9.30 and switch off at 19.00. In addition it should work on Saturday from 10.00 to 14.00 (Fig. 21).

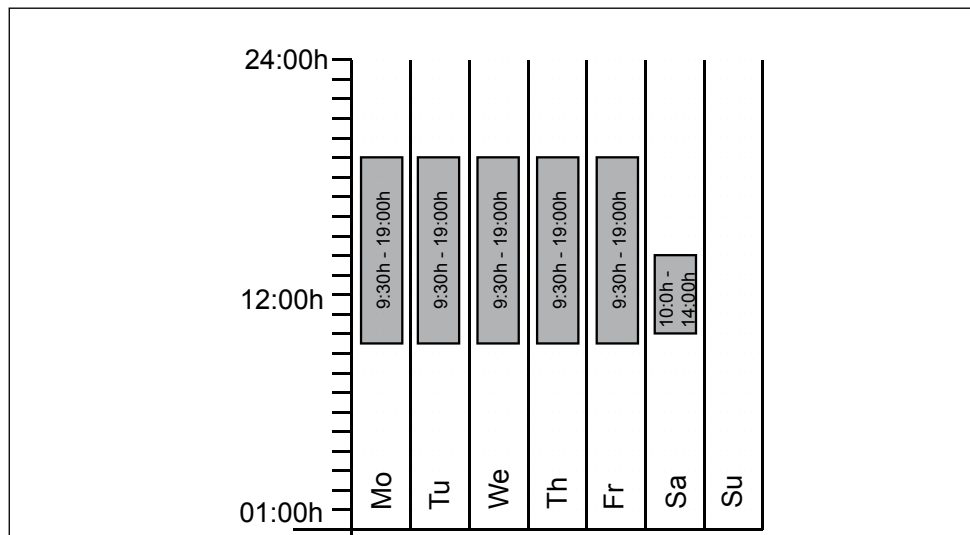

Fig. 21 Operation with week time switch (example)

1. Setting the week time switch operating mode

Hold the SET key down for approx. 3 seconds, the current operating mode then begins to flash. Select the week time switch operating mode with the push-turn control, while the SET key is held down.

Release the SET key, the control is now in the week time switch operating mode.



2. Switch on Mo-Fr at 09:30

Turning the push-turn control to the left, select the "MO-FR ON" icons (group working days).

Hold down the SET key and set the desired switch-on time with the push-turn switch to 9:30.



3. Switch off Mo-Fr at 19:00

Select "MO-FR OFF" (group working days) with the push-turn control.

Hold down the SET key and set the desired switch-off time with the push-turn switch to 19:00.



4. Switch on Sa at 10:00

With the push-turn control, select "SAT ON".
Hold down the SET key and set the desired switch-on time with the push-turn switch to 10:00.

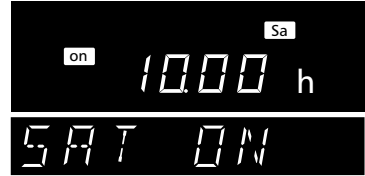

5. Switch off Sa at 14:00

With the push-turn control, select "SAT OFF".
Hold down the SET key and set the desired switch-off time with the push-turn switch to 14:00.



5.10.5 Operation with PC/laptop (optional)

If equipped with the communication or premium module, the incubator can optionally be used, controlled and programmed with a PC/laptop. It has corresponding communication interfaces for this purpose (see page 13 and page 55).



Operation is described in a separate manual. It is delivered with the incubator for the relevant models.

5.11 During operation

Regularly check the water level. If necessary, add distilled water.

Warning messages during operation: See Page 38.









CO₂ mode

In the heating up phase, the CO₂ controller is initially deactivated. The CO₂ intake is interrupted during this period. About 5 minutes after the setpoint temperature has been reached, the CO₂ control begins measuring and CO₂ gas is let in to the chamber via a sterile filter (the valve on the gas bottle must be open). To ensure a homogenous distribution of the CO₂ gas in the interior, the gas is piped in above the chamber fan. The setpoint can be adjusted in 0.1 % steps from 0 to 10% (for models with CO₂ or premium modules 0 to 20 %)

- After a sterilisation procedure, and in cycles every 24 hours, an automatic zero balance adjustment is carried out. This automatic zero balance adjustment is completed after a few minutes.

Displays in CO₂ mode:

	<p>HEAT UP is shown during the heating up phase of the CO₂ sensor. In the CO₂ display, CO₂ is shown.</p>
	<p>AUTOZERO - DO NOT OPEN DOOR is displayed during the zero balance adjustment.</p>

	<p>After the setpoint temperature has been reached, the CO₂ concentration is displayed in %, depending on the setting. IN 1 indicates that gas bottle 1 is active.</p>
	<p>Is displayed if the CO₂ concentration exceeds the defined setpoint by at least 1 % for more than 3 minutes. If the concentration is higher, the CO₂ display and the  icon flash.</p> <p>In this case you should open the door for 30 sec. and wait to see if the controller steadily adjusts to the setpoint. If the error occurs again, contact Customer Service.</p> <p> This monitoring function only starts to work once the CO₂ setpoint has been reached.</p>
	<p>CO₂ EMPTY is displayed if gas bottle 1 and/or 2 is/are empty. In this case, you should connect new gas bottles (see page 26).</p> <p> The pressure in the gas bottles is a constant approx. 57 bar at 20 °C ambient temperature. It is not possible to determine how full the bottle is through the pressure, since the pressure only drops immediately before the bottle is completely empty.</p>
	<p>The CO₂ supply is automatically interrupted when the outer doors are opened. DOOR OPEN is indicated in the text display.</p>
	<p>is displayed if the N₂ supply is interrupted. In this case, check if the N₂ bottle is correctly connected and if the valve is open.</p> <p>If that does not solve the problem, you should connect a new gas bottle (see page 23).</p>

Automatic switch-over of CO₂ gas bottles (only for models with comfort or premium modules)

The automatic switch-over of gas bottles guarantees an uninterrupted supply with CO₂ gas when two independent supply systems are connected.

- ▶ Gas bottle 1 is always the main supply bottle.
- ▶ Gas bottle 2 is always the reserve bottle.

Operation is only possible with one bottle. In this case it must be connected to IN1 (see also Fig. 4 on page 13).

- To be on the safe side, a freshly filled CO₂ gas bottle should always be used. So if the gas in bottle 1 is used up, you connect the opened bottle to IN1 and the newly filled bottle as a reserve bottle to IN2.

The hose connection system used by Memmert shuts off automatically if a connection hose is pulled off. You should still always close the stop valve on the gas bottle if a bottle is empty or not connected.

IN 1	lights up when gas bottle 1 is active. If gas bottle 1 is empty, there is an automatic switch-over to the reserve bottle.
IN 2	lights up after the switch-over to gas bottle 2 (reserve bottle). Switching over to the reserve bottle is marked by a short repeated acoustic signal (about 3 seconds long) (the default after switching on is gas bottle 1).

In the following cases, a switch-over is made from reserve bottle 2 back to the main supply bottle 1:

- ▶ if the reserve bottle is empty
- ▶ each time after the appliance is switched on
- ▶ after every change of the CO₂ setpoint

Humidity limit control

A humidity limit control prevents the formation of condensation water in the chamber and at the same time ensures that the setpoint humidity is quickly reached, with short recovery times.

The maximum achievable humidity can be adjusted in the standard model from 88 to 97% rh.

Active humidity control (only for models with humidity module)

The active humidity control guarantees that setpoint humidity is quickly reached, without the use of water trays.

In the heating up phase, the humidity control is initially deactivated. Approx. 5 minutes after the setpoint temperature is reached, the humidification and dehumidification control starts working. The setpoint can be set from 40 to 97 % rh. The humidity setpoint can also be adjusted during the transient state. For humidification, water is let into the chamber via a dosing pump. To avoid the formation of germs, the steam is first heated to approx. 140 °C. Dehumidification takes place through the supply of dry air via a sterile filter.

- If no humidity is required in the chamber, the humidity control can be deactivated by setting it to OFF.

5.12 Ending operation

1. Switch off appliance. To do this, press the main switch on the operating panel so that it clicks into place in the appliance (see Fig. 22).
2. Close the valve(s) of the gas bottle(s).
3. Open the door (see page 25).
4. Remove the chamber load.
5. For appliances with the basic model:
Remove and empty the water trays. Fill water trays and insert them only when the appliance is next used.
For incubators with a humidity module, empty the water tanks if the incubator is not used for several days.

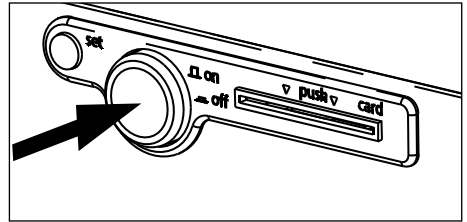



Fig. 22 Switching off incubator



6. Warning messages and malfunctions

6.1 Warning messages

i An intermittent tone is also set off by the warning messages. This can be temporarily switched off by pressing the SET key.

	DOOR OPEN if the door of appliance is opened for longer than 3 minutes.	Remedy: Close the door
----------------------------------------------------------------------------------	-------------------------------------------------------------------------	------------------------

Error in the temperature control system (see also Chapter "Temperature monitoring" on page 45):

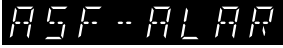
	TB ACTIVE - temperature limiter triggered if the temperature limiter responds	Remedy: Switch off the appliance and leave to cool down. If the error occurs again after switching the appliance back on: Switch off the appliance and Contact the customer service
	HI-ALARM! - overtemperature alarm limit max exceeded if overtemperature protection responds	Remedy: Check the setting of the MAX temperature monitoring (see Chapter "Temperature monitoring" on page 45.
	LO-ALARM! - undertemperature alarm limit min crossed if undertemperature protection responds	Remedy: Check the setting of the MIN temperature monitoring (see Chapter "Temperature monitoring" on page 45.
	ASF ALARM! - temperature outside tolerance band if automatic monitoring function responds	Remedy: Check the setting of the ASF temperature monitoring (see Chapter "Automatic temperature monitor (ASF)" on page 48.

Error in humidity system (only for appliances with humidity module)

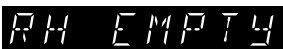
	if the water supply is defective	Remedy: Check that the water supply hose is properly connected. Fill the water supply tank with distilled water if it is empty.
------------------------------------------------------------------------------------	----------------------------------	---------------------------------------------------------------------------------------------------------------------------------

RH OVER	If humidity exceeds the preset setpoint for longer than 30 minutes.	Remedy: Open door for 30 sec. and wait to see if the controller steadily adjusts to the setpoint. If the error occurs again, Contact the customer service.
---------	---------------------------------------------------------------------	------------------------------------------------------------------------------------------------------------------------------------------------------------

Error in CO₂ system:

CO ₂ EMPTY	if the CO ₂ supply is defective	Remedy: Set CO ₂ setpoint value to 0, check stop valve of gas bottle(s) and ensure that they are properly connected; if gas bottle(s) empty, change gas bottles, set CO ₂ setpoint to desired value
CO ₂ OVER	If the CO ₂ concentration exceeds the defined setpoint by at least 1 % for more than 3 minutes.	Remedy: Open door for 30 sec. and wait to see if the controller steadily adjusts to the setpoint. If the error occurs again, Contact the customer service.

Error in O₂ system:

	if the N ₂ supply is defective	Remedy: check if the N ₂ bottle is correctly connected and if the valve is open. If that does not solve the problem, you should connect a new gas bottle (see page 23).
----------------------------------------------------------------------------------	-------------------------------------------	------------------------------------------------------------------------------------------------------------------------------------------------------------------------------------

6.2 System/appliance errors





Warning!

After removing covers, live parts may be exposed. You may receive an electric shock if you touch these parts. Malfunctions requiring intervention inside the appliance may only be rectified by electricians. You must read the separate service manual for the INCO incubator for this.

Do not try and rectify the error yourself, but contact an authorised customer service point for MEMMERT appliances or Contact the customer services department directly of the company MEMMERT (see page 2).

In case of enquiries, please always specify the model and appliance number on the nameplate (see page 15).

Error	Possible causes	Remedy
Nothing shows on the display although the incubator is switched on.	Power supply interrupted	Check power supply and fuse/safety switch.
	Appliance fuse or miniature fuse or controller faulty	Contact the customer service and read the service manual.
	Appliance error	
	Mainboard faulty	
Appliance cannot be operated	Incubator locked with user-ID card	Unlock incubator with user-ID card (see page 50).
	Push/turn control faulty	Contact the customer service and read the service manual.
No CO ₂ display shown in the CO ₂ module	Switched mode power supply SP 200 faulty	Contact the customer service and read the service manual.
 icon flashes ...	Temperature fuse (TWW, ASF) has responded	<ul style="list-style-type: none"> ▶ Increase temperature difference between monitoring and working temperature (see page 45). ▶ Replace Pt100 temperature sensor of monitoring controller if necessary (see Service manual)
... and RH EMPTY	Water supply tank empty	Set humidity setpoint to OFF, fill up distilled water, then reset humidity setpoint back to desired value.
... and RH EMPTY	Humidity setpoint exceeded	Open door for 30 sec. and wait to see if subsequently the controller steadily adjusts to the setpoint. If the error occurs again, Contact the customer service.
... and CO ₂ OVER	CO ₂ setpoint is exceeded	Open door for 30 sec. and wait to see if subsequently the controller steadily adjusts to the setpoint. If the error occurs again, Contact the customer service.
... and ERROR AUTOZERO	<ul style="list-style-type: none"> ▶ Autozero pump faulty ▶ CO₂ controller faulty 	Contact the customer service and read the service manual.
Error display (E...) in display	Appliance/system error	Contact the customer service and read the service manual.

Error	Possible causes	Remedy
Error message EOFF (is displayed for only 10 sec. after switching on)	Checksum error (error when saving setpoint values)	The error can be rectified just by the controller after a setpoint parameter has again been saved. If the error should continue occurring, or cannot be rectified: Contact the customer service and replace controller (see service manual)
Chamber fan without function	Miniature fuse or mains adapter faulty	Contact the customer service and read the service manual.
Heating icon  not on	▶ Ambient temperature too high	Setp the appliance up in a cooler room, minimum setpoint temperature = ambient temp. + 8 °C
	▶ Temperature in appliance higher than set setpoint temperature	Wait until appliance has cooled down.
 icon is permanently lit up	Temperature fuse has responded	<ul style="list-style-type: none"> ▶ Switch off appliance and leave to cool down ▶ Check temperature limiter The appliance is only operational again after it has cooled down and the error has been eliminated.
ERL O ₂ ERROR	Fault in oxygen calibration	Open the door for one minute and start calibration again. If the message appears gain: Contact the customer service.
ERROR O ₂ SENSOR	Oxygen sensor faulty	Contact the customer service

6.3 Power failure

In case of a power failure, the incubator operates as follows:

In normal and week time switch operating modes

After the power supply has been restored, operation is continued with the parameters set. The time and the duration of the power failure is documented in the log memory.

For remote operation

If there is a power failure in remote operation, the appliance starts in the normal operating mode for safety reasons and all setpoint values are changed to safe default values (see table). The programme can only be continued from the computer. The time and duration of the power failure are documented in the log memory.

Parameters	Default value
Temperature	20 °C
CO ₂	0 %
rh	OFF
O ₂ (only for models with O ₂ module)	OFF

7. Advanced functions

7.1 Printer

(only for models with communication or premium modules)

Incubators with a communication or premium module are equipped with a parallel printer port, as used in computers. Standard PCL3 compatible inkjet printers with a parallel port (e.g. HP DeskJet 5550 or HP DeskJet 9xx) can be connected to the printer interface on the rear of the appliance (see page).

Make sure that a shielded interface cable is used. The shielding must be connected to the plug casing.

The controller has an internal log memory (see page 58). The log data can be printed out in this mode via the connected printer.

If a colour printer is connected, the various graphs are printed out in colour.

For a printout, the GLP header is also printed automatically, containing the following details:

- ▶ Date of printout
- ▶ Period of log
- ▶ Consecutive page numbers
- ▶ Serial numbers and appliance name

Running the printing function:

Select the PRINT operating mode with the push-turn control, as described on page 28. By turning the push-turn control and holding down the SET key, the following parameters can be selected and altered one after another, as described in Chapter "Basic operation" on page 27:



Querying the date of the first print page

FIRST

Querying the date of the last print page

LAST

Starting graphical printout

GRAPH

Leaving the print menu and returning to the main menu

EXIT

7.2 Basic appliance settings (Setup)

(Setting options may vary depending on the appliance model)

In this operating mode, the basic settings for the appliance can be made. The time, date, day and year are set here, along with the settings for the horn, the address allocation, the monitoring units and the calibration.



By turning the push-turn control and holding down the SET key, the following parameters can be selected and altered one after another, as described in Chapter "Basic operation" on page 27:

Clock time in 24 hr. format

 Conversion to summer time is not automatic, but must be done manually.

Date

The controller contains a calendar which automatically accounts for the different lengths of months, and for leap years.

Weekday

Year

Adjustment range: from 2000 TO 2100

Acoustic signal at programme end

ENDSOUND

Setting: OFF or ON

Acoustic Signal for alarm, e.g. over/undertemperature

ALARM 50

Setting: OFF or ON

Communication address

Adjustment range: 0 to 15 (see Chapter "Communication interfaces" on page 55)

Tolerance band ASF

Adjustment range: 0.5 bis 5°C (see page 48)

Language

Setting: GERMAN, ENGLISH, FRANCAIS, ESPANOL AND ITALIANO

Corrective values (CAL 1-3, RH20, RH90) customer-side calibration of temperature and humidity (see Chapter "Calibration" on page 50)

Oxygen calibration (CAL O₂)
(only for models with O₂ module, see page 54)



Leave Setup

Save all settings and leave the SETUP mode.



The realtime clock, which is set in the SETUP, contains the date and clock time. It is used for logging purposes in accordance with GLP. Date and clock time are specified on the log printout. On graphical printouts, the time axis is labeled with the realtime. The clock is battery-buffered and independent of the mains connection. The integrated Lithium battery of the type CR 2032 has a lifetime of approx. 10 years.

7.3 Temperature monitoring

The monitoring temperature is measured via a separate Pt100 temperature sensor in the chamber interior. The monitoring unit is used to protect the chamber load and as a protection for the appliance and surroundings.

The appliance has a double overtemperature fuse (mechanical/electronic) in accordance with DIN 12880.

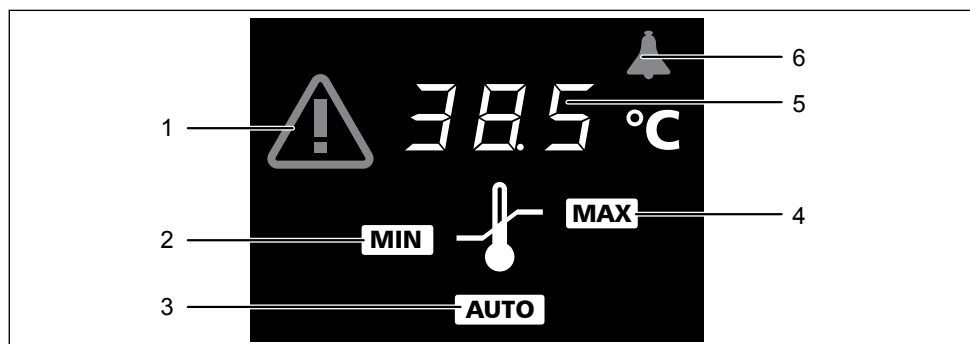

Fig. 23 Temperature monitoring display

- 1 Visual alarm icon
Lit up: TB alarm
Flashing: TWW alarm, ASF alarm
- 2 Undertemperature limit
- 3 Automatic temperature monitor (ASF, see page 48)
- 4 Overtemperature protection (TWW, TWB, see page 46)
- 5 Response temperature
- 6 Acoustic alarm icon

7.3.1 Mechanical temperature monitoring: temperature limiter (TB)

The incubator is equipped with a mechanical temperature limiter (TB) protection class 1 in accordance with DIN 12880.

If the electronic monitoring unit should fail during operation, and the factory preset maximum temperature is exceeded by approx. 20 °C, the temperature limiter, as the final protective measure, switches off the heating permanently. As a warning, the icon lights up.

Error rectification after the TB has been triggered:

1. Switch off appliance and leave to cool down
2. Contact the customer service and have the error rectified (e.g. replace temperature sensor).

The appliance is only operational again after it has cooled down and the error has been eliminated.

7.3.2 Electronic temperature monitoring (TWW)

Temperature monitoring can be adjusted independently of the operating modes.

The manually set monitoring temperature $\overline{\text{MIN}}$ and $\overline{\text{MAX}}$ the overtemperature control is monitored by an adjustable over/undertemperature controller (TWW) protection class 3.3 acc. to DIN 12880.

If the manually set monitoring temperature $\overline{\text{MAX}}$ is exceeded, the TWW takes over temperature control and begins to regulate the monitoring temperature (Fig. 21). The alarm icon flashes as a warning \triangle .

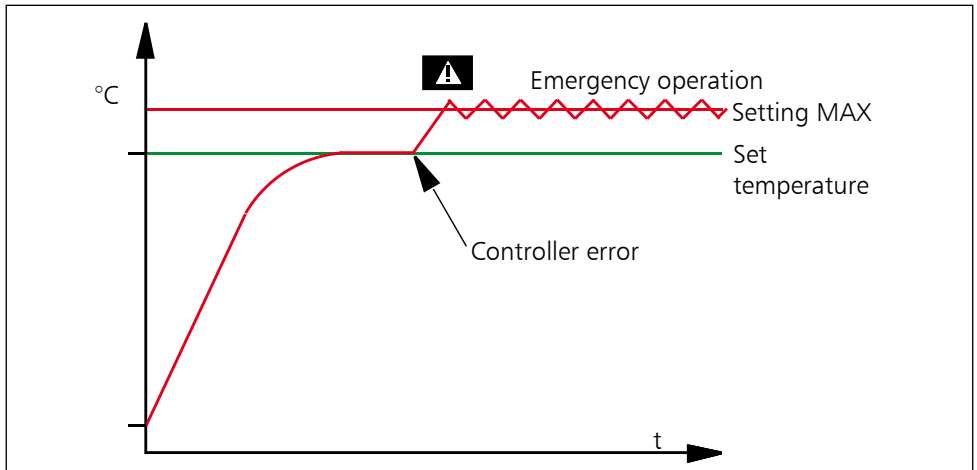

Fig. 24 Schematic diagram of how the TWW temperature monitoring functions

i The monitoring temperature must always be set sufficiently high above the maximum working temperature.

If the acoustic alarm is switched on in the SETUP, the TWW alarm is additionally signalled by an intermittent tone. If the SET key is pressed, the horn can be temporarily switched off until the next alarm event occurs.

Setting:

Overtemperature limit:

up to max. 10 °C above nominal temperature
(for details of the nominal temperature, see nameplate)

Setting:

1. Select the **MAX** icon with the push-turn control.
2. Hold down the SET key and set the desired temperature limit with the push-turn control (e.g. 385 °C).

Undertemperature limit:

Adjustment range: 10 °C below the minimum temperature of the appliance up to 10 °C above nominal temperature of the appliance (for details of the nominal temperature, see nameplate).

i The lower alarm limit value cannot be set higher than the top one. If no undertemperature limit is required, set the lowest temperature.

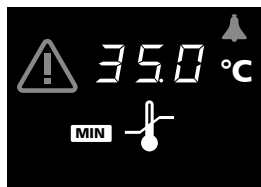

7.3.3 Automatic temperature monitor (ASF)

ASF is a monitoring device that automatically follows the set temperature setpoint within an adjustable tolerance band (Fig. 25).

The ASF is activated – if switched on – automatically if the actual temperature value reaches 50 % of the set tolerance band of the setpoint (in the example: 37 °C – 1.5 °C) reached for the first time (section A). The activation of the ASF is shown by the brightly lit **AUTO** icon.

When the temperature moves outside the set tolerance band around the setpoint (in the example in Fig. 25: 37 °C ± 3 °C) – e. g. if the door is opened during operation (section B of illustration) – the alarm is set off. This is shown by the flashing **AUTO** and **!** icons.

If the acoustic alarm is switched on in the SETUP, the ASF alarm is additionally signalled by an intermittent tone. If the SET key is pressed, the horn can be temporarily switched off until the next alarm event occurs.

The ASF alarm goes off automatically as soon as 50 % of the set tolerance band of the setpoint (in the example: 37 °C ± 1.5 °C) are reached again (section C).

If the temperature setpoint is altered, the ASF is automatically disabled temporarily (in the example: The setpoint is changed from 37 °C auf 30 °C, section D), until it has reached the tolerance range of the new temperature setpoint (section E).

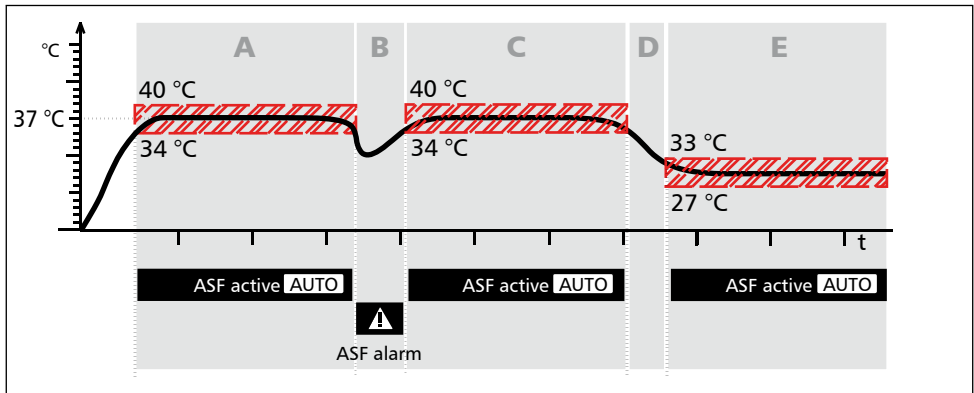
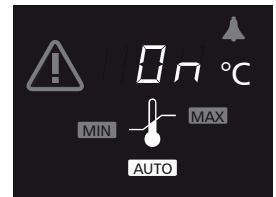

Fig. 25 Schematic diagram of how the ASF temperature monitoring functions

Switching on the automatic temperature monitor:

Select the AUTO icon with the push-turn control.

Hold down the SET key and set to **ON** with the push-turn control.



Switching off the automatic temperature monitor:

Select the AUTO icon with the push-turn control.

Hold down the SET key and set to **OFF** with the push-turn control.

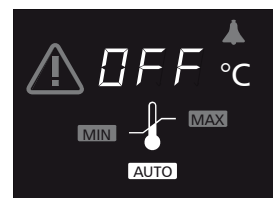

i The tolerance band for the ASF can be set in the SETUP in the range 0.5 ... 5 °C (see page 44).

7.4 Sterilisation chipcard

For decontamination, the incubator is equipped with a STERICard as standard (Fig. 26). The STERICard starts an automatic and predetermined sterilisation sequence.



Warning!
The incubator becomes very hot inside during the sterilisation procedure. Do not open the door.

Caution:
The sterilisation programme is not intended for sterilising the chamber load, but only for sterilising the interior of the appliance. The incubator is not a steriliser with respect to the Law on Medical Devices.

Make sure that the chamber is empty before the sterilisation procedure is started. Sliding shelves and removed water trays may also be sterilised.

To activate the STERICard, insert it into the chip card reader (see page 10) on the operating panel of the appliance and select the Start icon ► with the push-turn control while the SET key is held down.

As soon as the sterilisation procedure has been enabled, the automatic sterilisation procedure begins:

Ramp 1: Heating up to 160 °C

Ramp 2: Hold time 4 hours (after setpoint temperature has been reached)

Ramp 3: Cooling down to 70 °C

Ramp 4: Wait time of 10 minutes

i The automatic sterilisation programme cannot be changed.

After the sterilisation has been completed, STERILISATION OK is shown in the controller display. For documentation purposes, the sterilisation procedure is logged on the STERICard and can be read out with a computer/laptop.

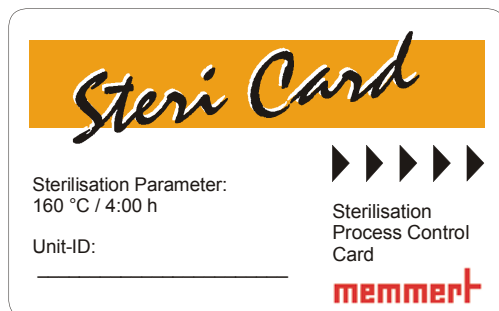

Fig. 26 STERICard

7.5 User ID card (optionally available as an accessory)

The device number of the incubator and a unique user number are stored in encrypted form on the user ID card (Fig. 27). The user ID card therefore works only in the appliance with the corresponding serial number.

To use it, insert the card into the chip card reader (see page 10) on the appliance operating panel.

If the user ID card has been inserted, the menu item **ID LOCK** also appears in the **SETUP** menu. If the setting is set to **ON**, the appliance is locked against all alterations once the chip card is removed.



Fig. 27 User ID Card

i Locking with the user ID card is displayed with the lit up icon on the operating panel.

Every login process with the user ID card is logged in the internal Flash memory of the controller.

7.6 Calibration

7.6.1 Temperature calibration

The incubator can be calibrated customer-specifically using three calibration temperatures of your choice:

- ▶ **CAL.1** Temperature calibration at low temperature (to 30°C)
- ▶ **CAL.2** Temperature calibration at medium temperature (from 30°C to 38°C)
- ▶ **CAL.3** Temperature calibration at high temperature (over 38°C)

For each selected balance point (Fig. 28) a positive or negative compensation correction value can be set between -2.9 °C and +2. 9 °C. There must be a difference of at least 10 °C between each of the individual balance points.

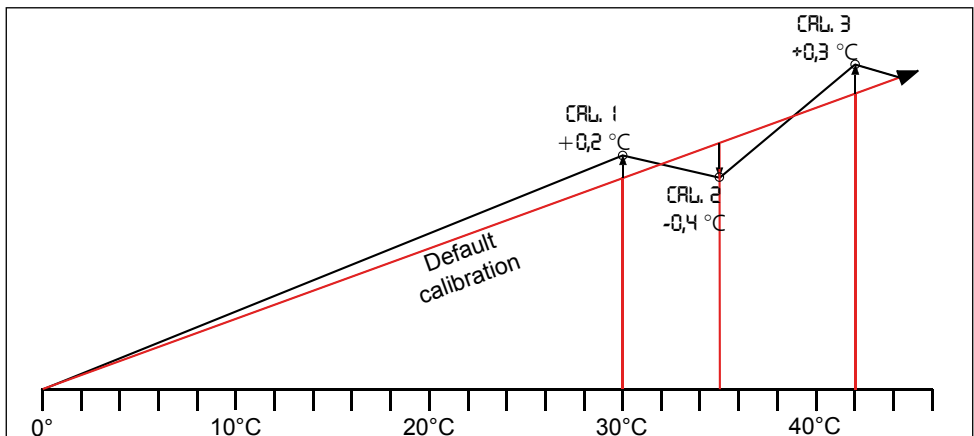

Fig. 28 Temperature calibration (example)

Setting:

1. Set compensation temperature in the SETUP (see page 44) and set accompanying compensation correction value to $0.0\text{ }^{\circ}\text{C}$.
2. With a reference instrument, measure the deviation in the stationary state in the selected compensation temperature.
3. Set the compensation correction value in the SETUP. If the measured reference temperature is too low, the compensation correction value must be set with a negative sign.
4. Perform a control measurement with the reference instrument.
5. Repeat the procedure for the other two balance points if necessary.

Example: The temperature deviation in the chamber load at $35\text{ }^{\circ}\text{C}$ should be corrected.

1. Set the compensation temperature CAL_2 IN THE SETUP TO $35.0\text{ }^{\circ}\text{C}$ and the accompanying compensation correction value to $0.0\text{ }^{\circ}\text{C}$:



2. With a calibrated reference instrument and at a set setpoint temperature of $35\text{ }^{\circ}\text{C}$ in normal operation, an actual temperature of $34.6\text{ }^{\circ}\text{C}$ is measured.
3. Set compensation correction value for CAL_2 in the SETUP to $-0.4\text{ }^{\circ}\text{C}$:



4. The reference instrument after the calibration procedure should now display $35\text{ }^{\circ}\text{C}$.
 5. With CAL_1 , another compensation temperature below CAL_2 can be programmed in the same way, and with CAL_3 , one lying above this.
- i** If all compensation correction values are set to $0.0\text{ }^{\circ}\text{C}$, the factory calibration settings are restored.

7.6.2 Humidity calibration

The incubator can be calibrated for the individual customer by means of two balance points at 20 and at 90 % relative humidity. For each selected balance point a positive or negative compensation correction value can be set between -5 % and +5 %.

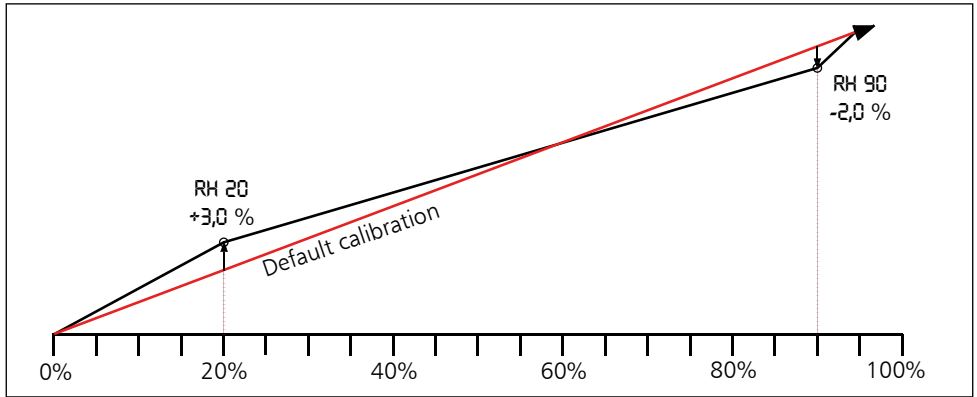

Fig. 29 Humidity calibration (example)

Setting:

1. Set the desired humidity balance point in the SETUP (see page 44) and set accompanying compensation correction value to 0.0 °C.
2. With a reference instrument, measure the deviation in the stationary state in the selected humidity balance point.
3. Setting the compensation correction value in the SETUP. If the measured reference humidity is too low, the compensation correction value must be set with a negative sign.
4. Perform a control measurement with the reference instrument.

The procedure can be performed with humidity balance points of 20% rh and 90% rh.

Example: Humidity deviation at 90 % should be corrected.

1. Set humidity balance point in the SETUP to RH 90 and set the accompanying compensation correction value to 0.0 %rh:



2. With a calibrated reference instrument, an actual humidity of 88% rh is measured at normal operation, with a set setpoint humidity of 90 %RH.
3. Set the compensation correction value in the SETUP for RH 90 TO -2.0 %RH:



4. The reference instrument should display 90.0% rh after the calibration procedure.

With RH 20 a further comparison can be programmed at 20 % relative humidity.

i If all compensation correction values are set to 0.0 % rh, the factory calibration settings are restored.

7.6.3 CO₂ calibration

Customer-side calibration of appliance on controller by means of three CO₂ points:

- ▶ CO₂ 5 CO₂ calibration at 5 % CO₂ content
- ▶ CO₂ 10 CO₂ calibration at 10 % CO₂ content
- ▶ CO₂ 15 CO₂ calibration at 15 % CO₂ content (only for models with CO₂ or premium modules)

For each selected balance point a positive or negative compensation correction value can be set.

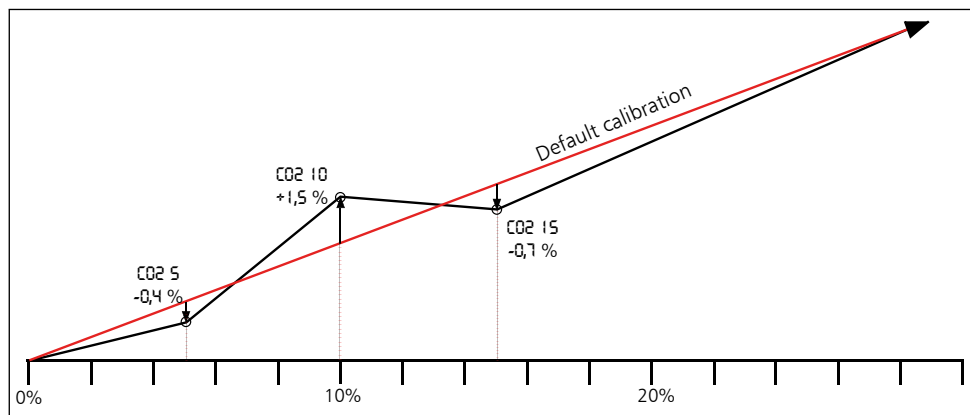

Fig. 30 CO₂ calibration (example)

Setting

5. Set the desired CO₂ balance point in the SETUP (see page 44) and set accompanying compensation correction value to 0.0 % rh.
6. With a reference instrument, measure the deviation in the stationary state in the selected CO₂ balance point.
7. Set the compensation correction value in the SETUP. If the measured reference CO₂ content is too low, the compensation correction value must be set with a negative sign.
8. Perform a control measurement with the reference instrument.
9. The procedure can be performed for the CO₂ balance points 5 %, 10 % and 15 % (15 % only for models with CO₂ or premium modules).

Example: CO₂ deviation in chamber load at 10 % should be corrected:

1. Set the CO₂ balance point in the SETUP to 00 10 and set the accompanying compensation correction value to 00 %:



2. With a calibrated reference instrument and at a set CO₂ content of 10.0 %, an actual CO₂ content of 11.5 % is measured.
3. Set the compensation correction value in the SETUP for 00 10 to 1.5 %:



4. The reference instrument should display 10 % after the calibration procedure.
- With 00 5 and 00 15, further calibrations can be programmed at 5 % and 15 % (15 % only for models with CO₂ or premium modules).

i If all compensation correction values are set to 00 %, the factory CO₂ calibration settings are restored.

7.6.4 Oxygen calibration

(only for models with O₂ module)

In the O₂ calibration, the oxygen proportion in the incubator at normal atmosphere is determined.

1. Switch off the O₂ module, if active. To do this, turn the push-turn control to the left until the O₂ display flashes. Hold down the set-key and turn the push-turn control until O₂ OFF is displayed. Release the set-key.
2. Set CO₂ setpoint value to 0% (see page 31).
3. Open the oven door and inner glass door, in case of four-part door, remove glass panes. Keep the doors open for at least one minute so that a normal atmosphere can form in the chamber. Close the doors again.
4. In the setup, select the item O₂ calibration with the push-turn control (CAL O₂ OFF). Hold down the set key and set to CAL O₂ ON with the push-turn control. Release the set key and leave the setup via EXIT.
Now, the oxygen content in the incubator is measured for about one minute. In the display, CAL O₂ ACTIVE can be seen. Do not switch off the oven while this is taking place.
5. When the calibration is finished, the oxygen content determined is shown in the display:



7.7 Communication interfaces

(only for models with communication or premium modules)

If the incubator is equipped with the communication or premium module, its log data can be read out with a computer/laptop. For this purpose, the incubator has corresponding communication interfaces on the rear of the appliance (see page 13).

To be able to use the RS 232, RS 485 And USB interfaces, the incubator must be assigned a unique device address in the SETUP, menu item ADDRESS (see page 44), via which the computer can communicate with the oven. The default setting is ADDRESS 0. Using this address, the appropriate incubator can be selected from the computer.

7.7.1 Communication Interface RS-232 C in accordance with DIN 12900-1

The computer can be connected with a shielded interface cable to the 9-pin interface on the rear of the appliance (see Fig. 31 and page 13). The shielding must be connected to the plug casing. If the serial port is not used, put on the cover included.

If several ovens are to be connected to a computer via RS-232-C interfaces, an appropriate interface on the computer and a separate cable are required for each oven (Fig. 32). The maximum cable length is 15 m.

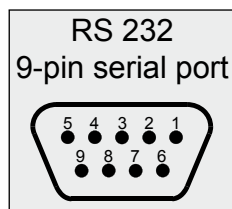

Fig. 31 RS-232-C interface

Pin allocation:

1	2	3	4	5	6	7	8	9
not occupied	RxD	TxD	not occupied	GND	not occupied	not occupied	not occupied	not occupied

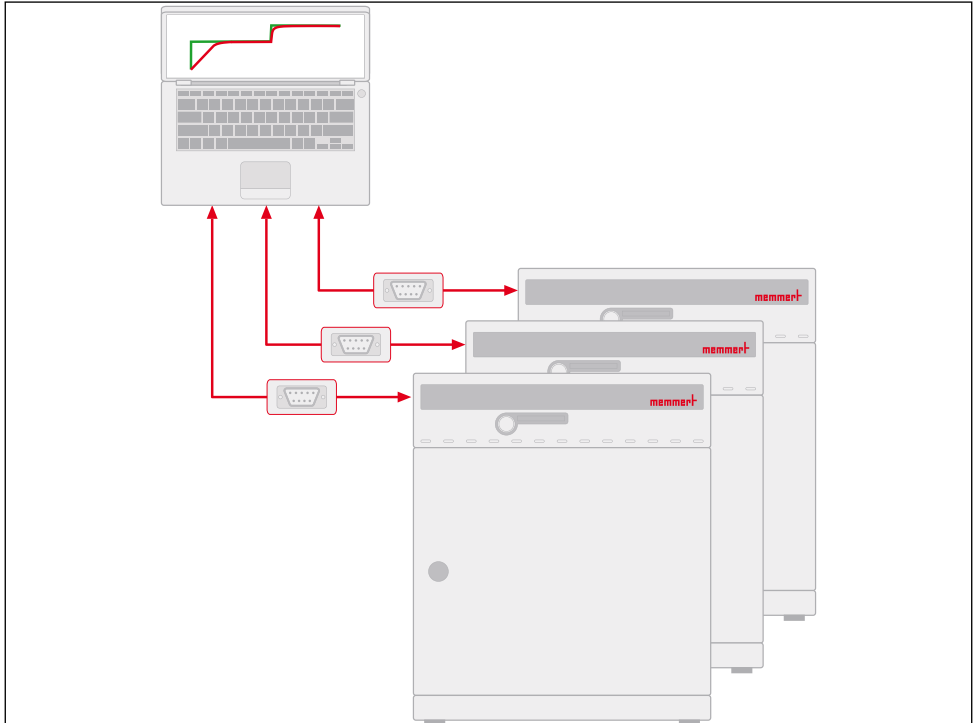

Fig. 32 Connecting incubators via the RS 232-C communication interface

7.7.2 Bus interface RS 485

If requested on the corresponding order, the oven can be fitted in the factory with a RS-485 interface instead of a RS-232-C interface. This enables the networking of several ovens (up to 16) with one computer via a shared two-wire cable (Fig. 34). The chamber must be given a unique device address in the SETUP submenu, menu item ADDRESS (see page 44), via which the computer communicates with the oven. A maximum of 16 devices can be addressed on the RS-485 bus.

The default setting is ADDRESS 0. Using this, the appropriate incubator can be selected and programmed from the PC.

The computer needs to be equipped with either an RS-485 interface or with an RS 232/RS 485 converter (Fig. 34). Connecting the wires is done individually with a shielded cable, depending on the installation site. The maximum total cable length is 150 m.

220 ohm terminating resistor must be connected to the last device.

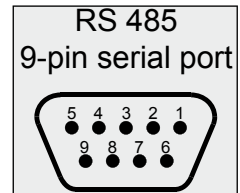

Fig. 33 RS-485 interface

Pin allocation:

1	2	3	4	5	6	7	8	9
not occupied	not occupied	A	not occupied	not occupied	not occupied	not occupied	B	not occupied

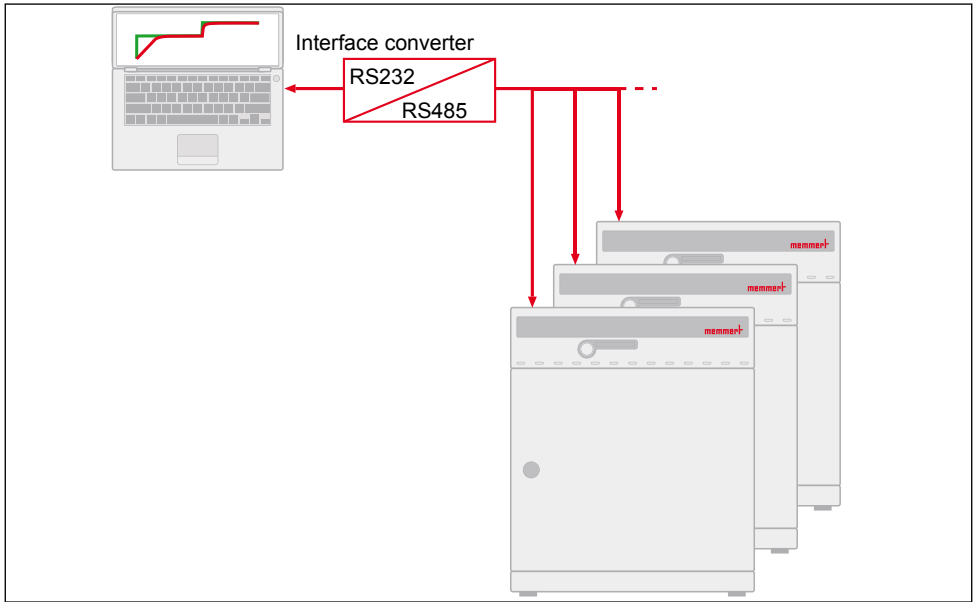

Fig. 34 Connecting incubators via the RS485 bus interface

7.7.3 USB interface

If several chambers are to be connected to a computer via USB interface, an appropriate interface on the computer and a separate cable are required for each chamber. The maximum cable length is 5 m.

7.7.4 Ethernet interface

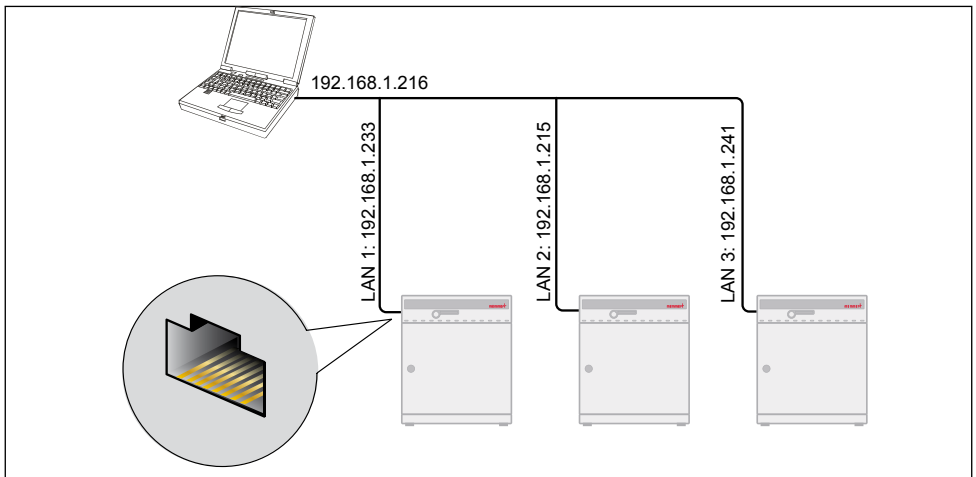

Fig. 35 Connecting one or more incubators to a network using an Ethernet interface (schematic diagram)

For identification purposes, each appliance connected must have its own unique IP address. Each chamber is delivered by default with the IP address 192.168.100.100. The program "XTADMIN", which can be found on the CD-ROM provided, can be used to change the IP address.



Setting the IP address is described in a separate manual.

7.8 Log memory

(only for models with communication or premium modules)

The controller continually logs all relevant measured values, settings and error messages at 1-minute intervals.

The internal log memory is listed as a ring memory, i. e. the oldest log data are always overwritten automatically with new data.

The logging function cannot be switched off, but is always active. The measured data are stored in the controller, safe from manipulation. Each dataset is stored with a unique timestamp.

The internal log memory has a size of 1024 kB. This corresponds to a storage capacity for about three months in permanent operation.

If the power supply is interrupted, the time of the power cut and the return of voltage are stored in the controller.

Reading in the log memory to the PC via USB interface

For documentation purposes, log data can be read out via an interface.



The log memory of the controller is not modified or deleted by the reading out.

Printing out log memory

(see also Chapter "Printer" on page 43)

For a printout, the GLP header is also printed automatically, and contains the following details:

- ▶ Date of printout
- ▶ Period of log
- ▶ Consecutive page numbers
- ▶ Serial numbers and appliance name



If the printer is not ready (e. g. ink cartridge or paper tray empty), no log data will be lost. Multiple printouts can also be made, since the log memory is not deleted after printing.

8. Maintenance and Servicing

8.1 Cleaning

**Warning!**

Danger of injury. Before any cleaning work, pull out the mains plug.

Regular cleaning of the easy-to-clean chamber interior prevents build up of material remains, which over time could impair the appearance and functionality of the stainless steel chamber.

To clean the interior, the fan cover can be removed by pulling it slightly forwards, after the two fixing screws have been screwed out (Fig. 36). The protective grid of the O₂ sensor can (if the model is equipped with a O₂ module) be taken off after the fixing screws have been removed (Fig. 37).

The metal surfaces of the chamber can be cleaned with normal stainless steel cleaning agents. Make sure that no rusty objects come into contact with the working chamber or with the stainless steel housing. Rust deposits lead to an infection of the stainless steel.

i If rust spots should appear on the surface of the working chamber, due to impurities, immediately clean and polish the affected area.

Do not clean the operating panel, the plastic input module and other plastic parts of the chamber with caustic or solvent-based cleaning agents.

8.2 Regular maintenance

Monthly

► For models with O₂ module: Perform oxygen calibration (see page 54).

Every three months

- Check that door seals fit tightly, adjust door if necessary (see page 60).
- In permanent mode: Grease the moving parts of the doors (hinges and lock) with thin silicone grease and check that the hinge screws are not loose.

Annually:

- Grease the moving parts of the doors (hinges and lock) with thin silicone grease and check that the hinge screws are not loose.
- Check that door seals fit tightly, adjust door if necessary (see page 60).



Fig. 36 To take off the fan cover, remove two screws

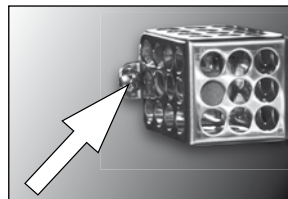

Fig. 37 O₂ sensor

8.3 Adjusting door

A well-closing door is indispensable for incubators. On Memmert appliances, the tight closing of the door is optimally guaranteed by a chamber seal and a door seal (see also page 10). In permanent operation, it is possible that the flexible seal material will begin to sag. To ensure that the door closes exactly despite this, an adjustment may be necessary (Fig. 38).

The top section (1) of the door hinge can be moved slightly in the direction of the arrow after the two screws (2) at the top and bottom of the door have been undone. Afterwards, tighten the screws down again.

Adjusting the door:

1. Undo the maggot screw (5) (with a jolting motion, as it is fixed with locking paint).
2. Adjust the door by turning the eccentric (3) with a screwdriver.
3. Apply locking paint to the maggot screw and re-tighten it.

The locking plate (Fig. 39) can also be adjusted in the direction of the arrows after undoing the screw (6).

1. Undo screw (6).
2. Move locking plate (7) in direction of arrow.
3. Tighten the screws again.

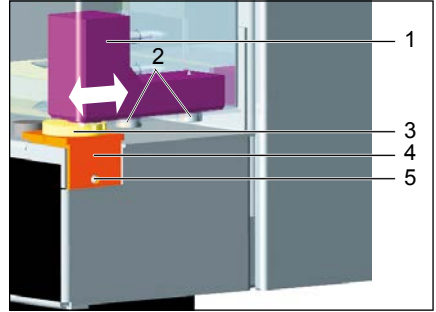

Fig. 38 Adjusting door
 1 Upper section of the door hinge
 2 Mounting bolts
 3 Eccentric tappet
 4 Eccentric socket
 5 Headless screw

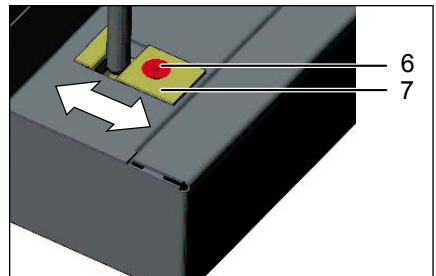

Fig. 39 Adjusting locking plate
 6 Screw
 7 Locking plate

8.4 Repairs and Service



Warning!

After removing covers, live parts may be exposed. You may receive an electric shock if you touch these parts. Disconnect the mains plug before removing any covers. Any work inside the unit may only be performed by qualified electricians.



Repairs and service work are described in a separate service manual for the INCO incubator.

9. Storage and Disposal

9.1 Storage

The incubator may only be used under the following conditions.

- ▶ Dry and in an enclosed, dust-free room
- ▶ Frost-free
- ▶ Disconnected from the power supply and gas supply

Undo gas bottle connections and close valves of gas bottles.

Gas bottles may be stored in closed rooms if these are sufficiently well ventilated.

For appliances with basic fittings:

Remove, empty and clean the water tray(s).

For appliances with the humidity module:

Undo hose connection of water supply tank; empty water tank.

9.2 Disposal

This product is subject to the Directive 2002/96/EC on Waste Electrical Electronic Equipment (WEEE) of the European Parliament and of the EU Council of Ministers. This appliance has been brought to the market after 13th August 2005 in countries which have already integrated this directive into their national laws. It may not be disposed of in normal household waste. To dispose, please contact your dealer or manufacturer. Any appliances that are infected, infectious or contaminated with materials that are a hazard to health are excluded from being taken back. Please observe the other regulations in this context.

Before disposing of the appliance, please render the door locking mechanism unusable, for example, to prevent playing children from being locked inside the appliance.

Note for Germany:

The appliance may not be left at public or communal recycling or collection points.

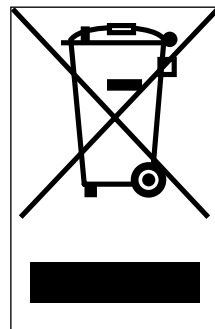

Index

- A**
- Accessories 18
 - Accidents 9
 - Acoustic signal 44
 - Additional modules 12
 - Adjusting door 60
 - Advanced functions 43
 - Ambient conditions 18
 - Appliance error 39
 - ASF 48
 - Automatic temperature monitor 48
- B**
- Base 21
 - Basic device settings 43
 - Basic equipment 11
- C**
- Calibration 44, 50
 - Chamber load 25
 - Changes 8
 - Checks 22
 - Chipcard 49
 - Cleaning 59
 - Clock time 44
 - CO₂ calibration 53
 - CO₂ setpoint 31
 - Communication address 44
 - Communication interfaces 55
 - Compensation temperature 51
 - Conformity 15
 - Connecting 22
 - Connection of external appliances 14
 - Connections 13
 - Conversions 8
 - Corrective values 44, 51, 53
 - Customer service 2
- D**
- Date 44
 - Declaration of conformity 15
 - Decommissioning 61
 - Delivery 19, 22
 - Design 10
 - Dimensions 17
 - Disposal 61
- Door** 25
- Door seals** 59
- E**
- EC Declaration of Conformity 15
 - Electrical connection 14
 - Electrical equipment 13
 - Electronic temperature monitoring 46
 - Emergency 9
 - Ending operation 37
 - ENDSOUND 44
 - Errors 39
 - Ethernet interface 57
 - Explosion protection 14
 - External devices 22
 - Extras 11
- F**
- Function 11
- G**
- Gas connection 14
 - Gas supply 26
- H**
- Hazards 7
 - How to set the IP address 58
 - Humidity calibration 52, 53
- I**
- Icons used 6
 - Intended use 14
 - Interface cable 43
 - Interface mode 28
 - Interfaces 55
 - Irregularities 8
- L**
- Language 44
 - Laptop 34
 - Length of lead 57
 - Loading 25
 - Log memory 42, 43
- M**
- Main switch 26
 - Maintenance 59
 - Malfunctions 8, 38
 - Manufacturer 2
 - Material 13
 - Memory 58
 - Messages 38
 - Minimum clearances 20
 - Monitoring temperature 45
- N**
- Nameplate 15
 - Normal mode 28, 29
- O**
- O₂ 17
 - O₂ module 12
 - O₂ setpoint 31
 - Operating modes 28
 - Operating mode - settings 28
 - Operating panel 27
 - Operating personnel 8, 25
 - Operation 25
 - Operation with PC/laptop 34
 - Operator 25
 - Oxygen calibration 45, 54
- P**
- Packaging material 19
 - Parameters 27
 - PC 34
 - Performance 16
 - Power failure 42
 - Power supply 22
 - Printer 43
 - Printing out log memory 58
 - Product safety 7
 - Pt100 temperature sensor 45
 - Push/turn control 26
 - Putting into Operation 22
- R**
- Realtime clock 45
 - Regular maintenance 59
 - Ring memory 58
 - RS-232 55
 - RS 485 56

- S**
- Safety regulations 6
 - Service 60
 - Servicing 59, 60
 - Setting parameters 27
 - Settings example normal mode 30
 - Settings example week time switch 33
 - Setup 19, 20, 43
 - Stacking frame 21
 - Standard accessories 18
 - Storage after delivery 20
 - Storage capacity 58
 - Switching off 26
 - Switching on 26
 - System impedance 22
- T**
- Technical data 16
 - Temperature calibration 50, 51
 - Temperature comparison 50
 - Temperature deviation 51
 - Temperature limiter (TB) 45
 - Temperature monitor 48
 - Temperature monitoring 45
 - Temperature monitoring (TWW) 46
 - Temperature sensor 45
 - Terms used 6
 - Tolerance band ASF 44
 - Transport 19
 - Transport damage 19
 - TWW 46
- U**
- Unpacking 19
 - USB interface 57
 - User ID card 50
- W**
- Warning messages 49
 - Water connection 22
 - Water tray(s) 26
 - Weekday 44
 - Week time switch 28, 31
 - Weight 16
 - What to do in case of accidents 9
- Y**
- Year 44

Memmert GmbH + Co KG | Postfach 1720 | D-91107 Schwabach | Tel. +49 (0) 9122-925-0 | Fax +49 (0) 9122-145-85 | E-Mail: service@memmert.com | www.memmert.com

05.11.2014

INCO/INCO med englisch

D23532