

# Operation

## Industrial Generator Sets

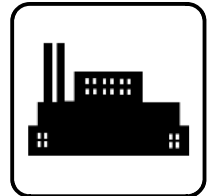

Models:

**20-2250 kW**

Controllers:

Decision-Maker™ 3+, 16-Light  
Software (Code) Version 1.10 or higher  
Decision-Maker™ 1

**KOHLER**<sup>®</sup>  
POWER SYSTEMS

**9001**  
**KOHLER**  
POWER SYSTEMS  
NATIONALLY REGISTERED

TP-6161 1/08f



# Table of Contents

<b>Product Identification Information</b> .....	<b>2</b>
<b>Safety Precautions and Instructions</b> .....	<b>5</b>
<b>Introduction</b> .....	<b>9</b>
Abbreviations .....	9
List of Related Materials .....	9
<b>Service Assistance</b> .....	<b>10</b>
<b>Section 1 Specifications and Features</b> .....	<b>11</b>
1.1 Introduction .....	11
1.2 16-Light Controller Features .....	11
1.2.1 Annunciator Panel Lamps .....	12
1.2.2 Auxiliary Fault Lamp .....	13
1.2.3 Fuses .....	13
1.2.4 Analog Meters and Gauges .....	13
1.2.5 Switches and Controls .....	14
1.2.6 Terminal Strips .....	14
1.2.7 DIP Switches .....	15
1.3 Expanded Decision-Maker 1 Controller .....	16
<b>Section 2 Operation</b> .....	<b>17</b>
2.1 Prestart Checklist .....	17
2.2 Generator Set Exercising .....	17
2.3 16-Light Controller Features .....	17
2.3.1 Normal Operation .....	17
2.3.2 Prime Power Mode Operation .....	18
2.3.3 Emergency Stopping .....	18
2.3.4 Fault Shutdowns .....	19
2.3.5 Controller Resetting After a Fault Shutdown .....	19
2.4 Expanded Decision-Maker 1 Controller .....	20
2.4.1 Generator Set Starting .....	20
2.4.2 Generator Set Stopping .....	20
2.4.3 Fault Shutdowns .....	20
2.4.4 Controller Resetting After a Fault Shutdown .....	20
<b>Section 3 Scheduled Maintenance</b> .....	<b>21</b>
3.1 Alternator Service .....	21
3.2 Engine Service .....	21
3.3 Service Schedule .....	22
3.4 Alternator Bearing Service .....	24
3.4.1 20-300 kW Models .....	24
3.4.2 350-2000 kW Models with Single- Bearing Alternator .....	24
3.4.3 1250-2000 kW Model with Two- Bearing Alternator .....	24
3.5 Diesel Fuel Systems .....	24
3.5.1 Bleeding Air from Fuel System .....	24
3.5.2 Subbase Inner Fuel Tank Alarm .....	25
3.6 Gas/Gasoline Fuel Systems .....	25
3.6.1 Gaseous Fuel System Concept .....	25
3.6.2 LP Liquid Withdrawal Fuel System Concept .....	26
3.6.3 LP Gas/Natural Gas Conversion for Straight Gas Fuel System .....	26
3.6.4 Fuel System Changeover Kits .....	27
3.6.5 Carburetor Adjustment .....	27
3.6.6 Fuel System Maintenance .....	27

# Table of Contents, continued

---

3.7	Cooling System	28
3.7.1	Coolant Level Check	28
3.7.2	Cooling System Component Inspection	28
3.7.3	Cooling System Drainage Procedure	28
3.7.4	Cooling System Flush and Clean Procedure	29
3.7.5	Cooling System Refilling Procedure	29
3.8	Radiator Fan Bolt Retorque	29
3.9	Radiator Fan Bearing Lubrication	30
3.10	Battery	31
3.10.1	Cleaning	33
3.10.2	Electrolyte Level Inspection	33
3.10.3	Specific Gravity Check	33
3.10.4	Charging	34
3.11	Detroit Diesel Engine Control Systems	34
3.11.1	Features	34
3.11.2	DDEC Engine Diagnostics	34
3.12	Engine Control Systems	35
3.13	Storage Procedure	35
3.13.1	Lubricating System	35
3.13.2	Cooling System	35
3.13.3	Fuel System	36
3.13.4	Internal Engine Components (Gas/Gasoline-Fueled Engines)	36
3.13.5	Exterior	36
3.13.6	Battery	36
<b>Section 4 Troubleshooting</b>		<b>37</b>
<b>Section 5 Generator Set Reconnection</b>		<b>41</b>
<b>Section 6 Accessories</b>		<b>47</b>
6.1	Accessories	47
6.1.1	Audiovisual Alarm (M)	47
6.1.2	Common Failure Relay Kit (M)	47
6.1.3	Controller Connection Kit (M)	47
6.1.4	Dry Contact Kit (Single-Relay) (M)	48
6.1.5	Dry Contact Kits (10-, 14-, and 20-Relay) (M)	48
6.1.6	Engine Prealarm Senders (M)	49
6.1.7	FASTCHECK Diagnostic Tester (M)	49
6.1.8	Float/Equalize Battery Charger Kit with Alarm Option (M)	49
6.1.9	Line Circuit Breaker	49
6.1.10	Low Fuel Switch (M)	50
6.1.11	Remote Annunciator Kit (M)	50
6.1.12	Remote Emergency Stop Kit (M)	50
6.1.13	Remote Serial Annunciator (M)	51
6.1.14	Run Relay Kit	51
6.1.15	Safeguard Breaker	51
6.2	Accessory and Prime Power Terminal Strip Connections (M)	52
6.3	Communication Module Kit and Gauge Driver Circuit Board	54
6.3.1	Communication Modules (Circuit Board) Versions	55
6.3.2	Circuit Boards Views	55
<b>Appendix A Abbreviations</b>		<b>57</b>

# Safety Precautions and Instructions

IMPORTANT SAFETY INSTRUCTIONS. Electromechanical equipment, including generator sets, transfer switches, switchgear, and accessories, can cause bodily harm and pose life-threatening danger when improperly installed, operated, or maintained. To prevent accidents be aware of potential dangers and act safely. Read and follow all safety precautions and instructions. **SAVE THESE INSTRUCTIONS.**

This manual has several types of safety precautions and instructions: Danger, Warning, Caution, and Notice.

## DANGER

Danger indicates the presence of a hazard that **will cause severe personal injury, death, or substantial property damage.**

## WARNING

Warning indicates the presence of a hazard that **can cause severe personal injury, death, or substantial property damage.**

## CAUTION

Caution indicates the presence of a hazard that **will or can cause minor personal injury or property damage.**

## NOTICE

Notice communicates installation, operation, or maintenance information that is safety related but not hazard related.

Safety decals affixed to the equipment in prominent places alert the operator or service technician to potential hazards and explain how to act safely. The decals are shown throughout this publication to improve operator recognition. Replace missing or damaged decals.

## Accidental Starting

### WARNING



**Accidental starting.  
Can cause severe injury or death.**

Disconnect the battery cables before working on the generator set. Remove the negative (-) lead first when disconnecting the battery. Reconnect the negative (-) lead last when reconnecting the battery.

**Disabling the generator set. Accidental starting can cause severe injury or death.** Before working on the generator set or connected equipment, disable the generator set as follows: (1) Move the generator set master switch to the OFF position. (2) Disconnect the power to the battery charger. (3) Remove the battery cables, negative (-) lead first. Reconnect the negative (-) lead last when reconnecting the battery. Follow these precautions to prevent starting of the generator set by an automatic transfer switch, remote start/stop switch, or engine start command from a remote computer.

## Battery

### WARNING



**Sulfuric acid in batteries.  
Can cause severe injury or death.**

Wear protective goggles and clothing. Battery acid may cause blindness and burn skin.

### WARNING



**Explosion.  
Can cause severe injury or death.  
Relays in the battery charger  
cause arcs or sparks.**

Locate the battery in a well-ventilated area. Isolate the battery charger from explosive fumes.

**Battery electrolyte is a diluted sulfuric acid. Battery acid can cause severe injury or death.** Battery acid can cause blindness and burn skin. Always wear splashproof safety goggles, rubber gloves, and boots when servicing the battery. Do not open a sealed battery or mutilate the battery case. If battery acid splashes in the eyes or on the skin, immediately flush the affected area for 15 minutes with large quantities of clean water. Seek immediate medical aid in the case of eye contact. Never add acid to a battery after placing the battery in service, as this may result in hazardous spattering of battery acid.

**Battery acid cleanup. Battery acid can cause severe injury or death.** Battery acid is electrically conductive and corrosive. Add 500 g (1 lb.) of bicarbonate of soda (baking soda) to a container with 4 L (1 gal.) of water and mix the neutralizing solution. Pour the neutralizing solution on the spilled battery acid and continue to add the neutralizing solution to the spilled battery acid until all evidence of a chemical reaction (foaming) has ceased. Flush the resulting liquid with water and dry the area.

**Battery gases. Explosion can cause severe injury or death.** Battery gases can cause an explosion. Do not smoke or permit flames or sparks to occur near a battery at any time, particularly when it is charging. Do not dispose of a battery in a fire. To prevent burns and sparks that could cause an explosion, avoid touching the battery terminals with tools or other metal objects. Remove all jewelry before servicing the equipment. Discharge static electricity from your body before touching batteries by first touching a grounded metal surface away from the battery. To avoid sparks, do not disturb the battery charger connections while the battery is charging. Always turn the battery charger off before disconnecting the battery connections. Ventilate the compartments containing batteries to prevent accumulation of explosive gases.

**Battery short circuits. Explosion can cause severe injury or death.** Short circuits can cause bodily injury and/or equipment damage. Disconnect the battery before generator set installation or maintenance. Remove all jewelry before servicing the equipment. Use tools with insulated handles. Remove the negative (-) lead first when disconnecting the battery. Reconnect the negative (-) lead last when reconnecting the battery. Never connect the negative (-) battery cable to the positive (+) connection terminal of the starter solenoid. Do not test the battery condition by shorting the terminals together.

## Engine Backfire/Flash Fire

<b>⚠ WARNING</b>

<b>Fire.</b> <b>Can cause severe injury or death.</b>
Do not smoke or permit flames or sparks near fuels or the fuel system.

**Servicing the fuel system. A flash fire can cause severe injury or death.** Do not smoke or permit flames or sparks near the carburetor, fuel line, fuel filter, fuel pump, or other potential sources of spilled fuels or fuel vapors. Catch fuels in an approved container when removing the fuel line or carburetor.

**Servicing the air cleaner. A sudden backfire can cause severe injury or death.** Do not operate the generator set with the air cleaner removed.

**Combustible materials. A fire can cause severe injury or death.** Generator set engine fuels and fuel vapors are flammable and explosive. Handle these materials carefully to minimize the risk of fire or explosion. Equip the compartment or nearby area with a fully charged fire extinguisher. Select a fire extinguisher rated ABC or BC for electrical fires or as recommended by the local fire code or an authorized agency. Train all personnel on fire extinguisher operation and fire prevention procedures.

## Exhaust System

<b>⚠ WARNING</b>

<b>Carbon monoxide.</b> <b>Can cause severe nausea, fainting, or death.</b>
The exhaust system must be leakproof and routinely inspected.

**Generator set operation. Carbon monoxide can cause severe nausea, fainting, or death.** Carbon monoxide is an odorless, colorless, tasteless, nonirritating gas that can cause death if inhaled for even a short time. Avoid breathing exhaust fumes when working on or near the generator set. Never operate the generator set inside a building unless the exhaust gas is piped safely outside. Never operate the generator set where exhaust gas could accumulate and seep back inside a potentially occupied building.

**Carbon monoxide symptoms. Carbon monoxide can cause severe nausea, fainting, or death.** Carbon monoxide is a poisonous gas present in exhaust gases. Carbon monoxide is an odorless, colorless, tasteless, nonirritating gas that can cause death if inhaled for even a short time. Carbon monoxide poisoning symptoms include but are not limited to the following:

- Light-headedness, dizziness
- Physical fatigue, weakness in joints and muscles
- Sleepiness, mental fatigue, inability to concentrate or speak clearly, blurred vision
- Stomachache, vomiting, nausea

If experiencing any of these symptoms and carbon monoxide poisoning is possible, seek fresh air immediately and remain active. Do not sit, lie down, or fall asleep. Alert others to the possibility of carbon monoxide poisoning. Seek medical attention if the condition of affected persons does not improve within minutes of breathing fresh air.

## Fuel System

### ⚠ WARNING



**Explosive fuel vapors.**  
**Can cause severe injury or death.**

Use extreme care when handling, storing, and using fuels.

**The fuel system. Explosive fuel vapors can cause severe injury or death.** Vaporized fuels are highly explosive. Use extreme care when handling and storing fuels. Store fuels in a well-ventilated area away from spark-producing equipment and out of the reach of children. Never add fuel to the tank while the engine is running because spilled fuel may ignite on contact with hot parts or from sparks. Do not smoke or permit flames or sparks to occur near sources of spilled fuel or fuel vapors. Keep the fuel lines and connections tight and in good condition. Do not replace flexible fuel lines with rigid lines. Use flexible sections to avoid fuel line breakage caused by vibration. Do not operate the generator set in the presence of fuel

leaks, fuel accumulation, or sparks. Repair fuel systems before resuming generator set operation.

**Explosive fuel vapors can cause severe injury or death.** Take additional precautions when using the following fuels:

**Gasoline**—Store gasoline only in approved red containers clearly marked GASOLINE.

**Propane (LP)**—Adequate ventilation is mandatory. Because propane is heavier than air, install propane gas detectors low in a room. Inspect the detectors per the manufacturer's instructions.

**Natural Gas**—Adequate ventilation is mandatory. Because natural gas rises, install natural gas detectors high in a room. Inspect the detectors per the manufacturer's instructions.

**Fuel tanks. Explosive fuel vapors can cause severe injury or death.** Gasoline and other volatile fuels stored in day tanks or subbase fuel tanks can cause an explosion. Store only diesel fuel in tanks.

**Draining the fuel system. Explosive fuel vapors can cause severe injury or death.** Spilled fuel can cause an explosion. Use a container to catch fuel when draining the fuel system. Wipe up spilled fuel after draining the system.

**Gas fuel leaks. Explosive fuel vapors can cause severe injury or death.** Fuel leakage can cause an explosion. Check the LP vapor gas or natural gas fuel system for leakage by using a soap and water solution with the fuel system test pressurized to 6–8 ounces per square inch (10–14 inches water column). Do not use a soap solution containing either ammonia or chlorine because both prevent bubble formation. A successful test depends on the ability of the solution to bubble.

**LP liquid withdrawal fuel leaks. Explosive fuel vapors can cause severe injury or death.** Fuel leakage can cause an explosion. Check the LP liquid withdrawal gas fuel system for leakage by using a soap and water solution with the fuel system test pressurized to at least 90 psi (621 kPa). Do not use a soap solution containing either ammonia or chlorine because both prevent bubble formation. A successful test depends on the ability of the solution to bubble.

## Hazardous Noise

**CAUTION**



**Hazardous noise.  
Can cause hearing loss.**

Never operate the generator set without a muffler or with a faulty exhaust system.

**Engine noise. Hazardous noise can cause hearing loss.** Generator sets not equipped with sound enclosures can produce noise levels greater than 105 dBA. Prolonged exposure to noise levels greater than 85 dBA can cause permanent hearing loss. Wear hearing protection when near an operating generator set.

## Hazardous Voltage/ Moving Parts

**DANGER**



**Hazardous voltage.  
Will cause severe injury or death.**

Disconnect all power sources before opening the enclosure.

**WARNING**



**Hazardous voltage. Moving parts.  
Can cause severe injury or death.**

Operate the generator set only when all guards and electrical enclosures are in place.

**WARNING**



**Hazardous voltage.  
Backfeed to the utility system can cause property damage, severe injury, or death.**

If the generator set is used for standby power, install an automatic transfer switch to prevent inadvertent interconnection of standby and normal sources of supply.

**Grounding electrical equipment. Hazardous voltage can cause severe injury or death.** Electrocutation is possible whenever electricity is present. Ensure you comply with all applicable codes and standards. Electrically ground the generator set, transfer switch, and related equipment and electrical circuits. Turn off the main circuit breakers of all power sources before servicing the equipment. Never contact electrical leads or appliances when standing in water or on wet ground because these conditions increase the risk of electrocution.

**Installing the battery charger. Hazardous voltage can cause severe injury or death.** An ungrounded battery charger may cause electrical shock. Connect the battery charger enclosure to the ground of a permanent wiring system. As an alternative, install an equipment grounding conductor with circuit conductors and connect it to the equipment grounding terminal or the lead on the battery charger. Install the battery charger as prescribed in the equipment manual. Install the battery charger in compliance with local codes and ordinances.

**Connecting the battery and the battery charger. Hazardous voltage can cause severe injury or death.** Reconnect the battery correctly, positive to positive and negative to negative, to avoid electrical shock and damage to the battery charger and battery(ies). Have a qualified electrician install the battery(ies).

**Short circuits. Hazardous voltage/current can cause severe injury or death.** Short circuits can cause bodily injury and/or equipment damage. Do not contact electrical connections with tools or jewelry while making adjustments or repairs. Remove all jewelry before servicing the equipment.

**Engine block heater. Hazardous voltage can cause severe injury or death.** The engine block heater can cause electrical shock. Remove the engine block heater plug from the electrical outlet before working on the block heater electrical connections.

**Handling the capacitor. Hazardous voltage can cause severe injury or death.** Electrical shock results from touching the charged capacitor terminals. Discharge the capacitor by shorting the terminals together. *(Capacitor-excited models only)*

**Electrical backfeed to the utility. Hazardous backfeed voltage can cause severe injury or death.** Install a transfer switch in standby power installations to prevent the connection of standby and other sources of power. Electrical backfeed into a utility electrical system can cause severe injury or death to utility personnel working on power lines.

**Testing live electrical circuits. Hazardous voltage or current can cause severe injury or death.** Have trained and qualified personnel take diagnostic measurements of live circuits. Use adequately rated test equipment with electrically insulated probes and follow the instructions of the test equipment manufacturer when performing voltage tests. Observe the following precautions when performing voltage tests: (1) Remove all jewelry. (2) Stand on a dry, approved electrically insulated mat. (3) Do not touch the enclosure or components inside the enclosure. (4) Be prepared for the system to operate automatically. *(600 volts and under)*

**⚠ WARNING**



**Airborne particles. Can cause severe injury or blindness.**

Wear protective goggles and clothing when using power tools, hand tools, or compressed air.

**Servicing the generator set when it is operating. Exposed moving parts can cause severe injury or death.** Keep hands, feet, hair, clothing, and test leads away from the belts and pulleys when the generator set is running. Replace guards, screens, and covers before operating the generator set.

**Heavy Equipment**

**⚠ WARNING**



**Unbalanced weight. Improper lifting can cause severe injury or death and equipment damage.**

Do not use lifting eyes. Lift the generator set using lifting bars inserted through the lifting holes on the skid.

**Hot Parts**

**⚠ WARNING**



**Hot coolant and steam. Can cause severe injury or death.**

Before removing the pressure cap, stop the generator set and allow it to cool. Then loosen the pressure cap to relieve pressure.

**⚠ WARNING**



**Hot engine and exhaust system. Can cause severe injury or death.**

Do not work on the generator set until it cools.

**Servicing the alternator. Hot parts can cause severe injury or death.** Avoid touching the alternator field or exciter armature. When shorted, the alternator field and exciter armature become hot enough to cause severe burns.

**Servicing the exhaust system. Hot parts can cause severe injury or death.** Do not touch hot engine parts. The engine and exhaust system components become extremely hot during operation.

**Notice**

**NOTICE**

**This generator set has been rewired from its nameplate voltage to**



246242

**NOTICE**

**Voltage reconnection.** Affix a notice to the generator set after reconnecting the set to a voltage different from the voltage on the nameplate. Order voltage reconnection decal 246242 from an authorized service distributor/dealer.

**NOTICE**

**Canadian installations only.** For standby service connect the output of the generator set to a suitably rated transfer switch in accordance with Canadian Electrical Code, Part 1.



This manual provides operation instructions for 20–2250 kW generator sets equipped with the following controllers:

- Decision-Maker™ 3+, 16-Light
- Decision-Maker™ 1

Wiring diagram manuals are available separately. Refer to the engine operation manual for generator set engine scheduled maintenance information.

Information in this publication represents data available at the time of print. Kohler Co. reserves the right to change this publication and the products represented without notice and without any obligation or liability whatsoever.

Read this manual and carefully follow all procedures and safety precautions to ensure proper equipment operation and to avoid bodily injury. Read and follow the Safety Precautions and Instructions section at the beginning of this manual. Keep this manual with the equipment for future reference.

The equipment service requirements are very important to safe and efficient operation. Inspect the parts often and perform required service at the prescribed intervals. Maintenance work must be performed by appropriately skilled and suitably trained maintenance personnel familiar with generator set operation and service.

## Abbreviations

This publication makes use of numerous abbreviations. Typically, the word(s) are spelled out along with the abbreviation in parentheses when shown for the first time in a section. Appendix A, Abbreviations, also includes many abbreviation definitions.

## List of Related Materials

Separate literature contains communication and software information for the 16-Light Controller with communications not provided in this manual. Figure 1 lists the available literature part numbers.

Communication and Software Manual Description	Literature Part No.
16-Light Controller Spec Sheet	G6-30
Decision-Maker™ 1 Controller Spec Sheet	G6-29
Generator Set/Controller Wiring Diagram Manual	Multiple Part Numbers Contact your Distributor/Dealer
Modbus® Communications Protocol Operation Manual	TP-6113
Service Parts Controllers	TP-6009
Program Loader Software Installation	TT-1285
Remote Serial Annunciator (RSA)	TT-1377
Controller Service Replacement	TT-1310
Monitor III Converters, Connections, and Controller Setup	TT-1405
Monitor III Software Spec Sheet	G6-76
Monitor III Converter, Modbus®/Ethernet Spec Sheet	G6-79
Monitor III Software Operation Manual	TP-6347

**Figure 1** Related Literature

Several engine manufacturers provide engines with electronic controls. These electronic controls indicate fault codes in addition to the generator set controller. Use Figure 2 for literature part numbers relating to the identifying engine fault codes. For the latest literature part numbers, see the respective Parts Catalog.

Model	Literature Part No.	Description
30 kW and 80–125 kW GM	TP-6215	Engine ECM Service Manual
80–200 kW John Deere 4045/6068	TP-6285	Engine Operation Manual
275–500 kW Kohler Branded Engines	TP-6218	Engine Operation Manual
135–275 kW DDC Series 50/60 Gas	TP-5830	Natural Gas Generator Set Engine Operator's Guide
230–450 kW DDC Series 60	TP-6056	DDEC IV Application and Installation Manual
230–450 kW DDC Series 60	TP-5611	Engine Operator's Guide
450/500 kW DDC Series 2000	TP-6361	DDEC IV ECM Troubleshooting Guide
650–1000 kW DDC Series 2000	TP-6375	Engine Operating Instructions (MDEC)
650–1000 kW DDC/MTU Series 2000	TP-6502	Engine Operating Instructions (ADEC)
1250–2250 kW DDC/MTU Series 4000	TP-6503	Engine Operating Instructions (ADEC)
1350–2000 kW DDC/MTU Series 4000	TP-6237	Engine Operating Instructions (MDEC)

**Figure 2** Related Engine Literature

Modbus® is a registered trademark of Schneider Electric.

## Tech Tools

Use your SecurID to access the KOHLERnet and click on Tech Tools button to find the following topics:

- **Software** used by generator set controllers including updates and documentation references.

- **Network Communications** provides basics to terms, protocols, standards, wiring, configurations, and model.
- **Engine Electronic Control Module (ECM)** has information about electronic devices provided by the engine manufacturer to manage engine data.

## Service Assistance

---

For professional advice on generator set power requirements and conscientious service, please contact your nearest Kohler distributor or dealer.

- Consult the Yellow Pages under the heading Generators—Electric.
- Visit the Kohler Power Systems website at KohlerPower.com.
- Look at the labels and stickers on your Kohler product or review the appropriate literature or documents included with the product.
- Call toll free in the US and Canada 1-800-544-2444.
- Outside the US and Canada, call the nearest regional office.

### Headquarters Europe, Middle East, Africa (EMEA)

Kohler Power Systems  
3 rue de Brennus  
93200 Saint Denis  
France  
Phone: (33) 1 49 178300  
Fax: (33) 1 49 178301

### Asia Pacific

Power Systems Asia Pacific Regional Office  
Singapore, Republic of Singapore  
Phone: (65) 6264-6422  
Fax: (65) 6264-6455

### China

North China Regional Office, Beijing  
Phone: (86) 10 6518 7950  
(86) 10 6518 7951  
(86) 10 6518 7952  
Fax: (86) 10 6518 7955

East China Regional Office, Shanghai  
Phone: (86) 21 6288 0500  
Fax: (86) 21 6288 0550

### India, Bangladesh, Sri Lanka

India Regional Office  
Bangalore, India  
Phone: (91) 80 3366208  
(91) 80 3366231  
Fax: (91) 80 3315972

### Japan, Korea

North Asia Regional Office  
Tokyo, Japan  
Phone: (813) 3440-4515  
Fax: (813) 3440-2727

### Latin America

Latin America Regional Office  
Lakeland, Florida, USA  
Phone: (863) 619-7568  
Fax: (863) 701-7131

# Section 1 Specifications and Features

## 1.1 Introduction

The specification sheets for each generator set provide specific generator and engine information. Refer to the respective specification sheet for data not supplied in this manual. Consult the generator set service manual, installation manual, engine operation manual, and engine service manual for additional specifications.

## 1.2 16-Light Controller Features

The 16-light controller can operate in either the normal mode or the prime power mode. The prime power mode allows reduced controller current draw in applications without a battery charger, minimizing battery drain by the controller circuitry. See Section 2.3.2, Prime Power Mode Operation, for more information.

Figure 1-1 shows the 16-light (level 1) controller. The 16-light controller features include annunciator panel lamps, analog meters, switches and controls, and fuses and terminal strips. For identification and an explanation of the functions, see Sections 1.2.1 through 1.2.7.

**Note:** Some installations use modified 16-light microprocessor controllers with switchgear applications. These nonstandard controllers may have remote start and no time delay for engine cooldown circuitry. Consult the switchgear literature for configuration and function.

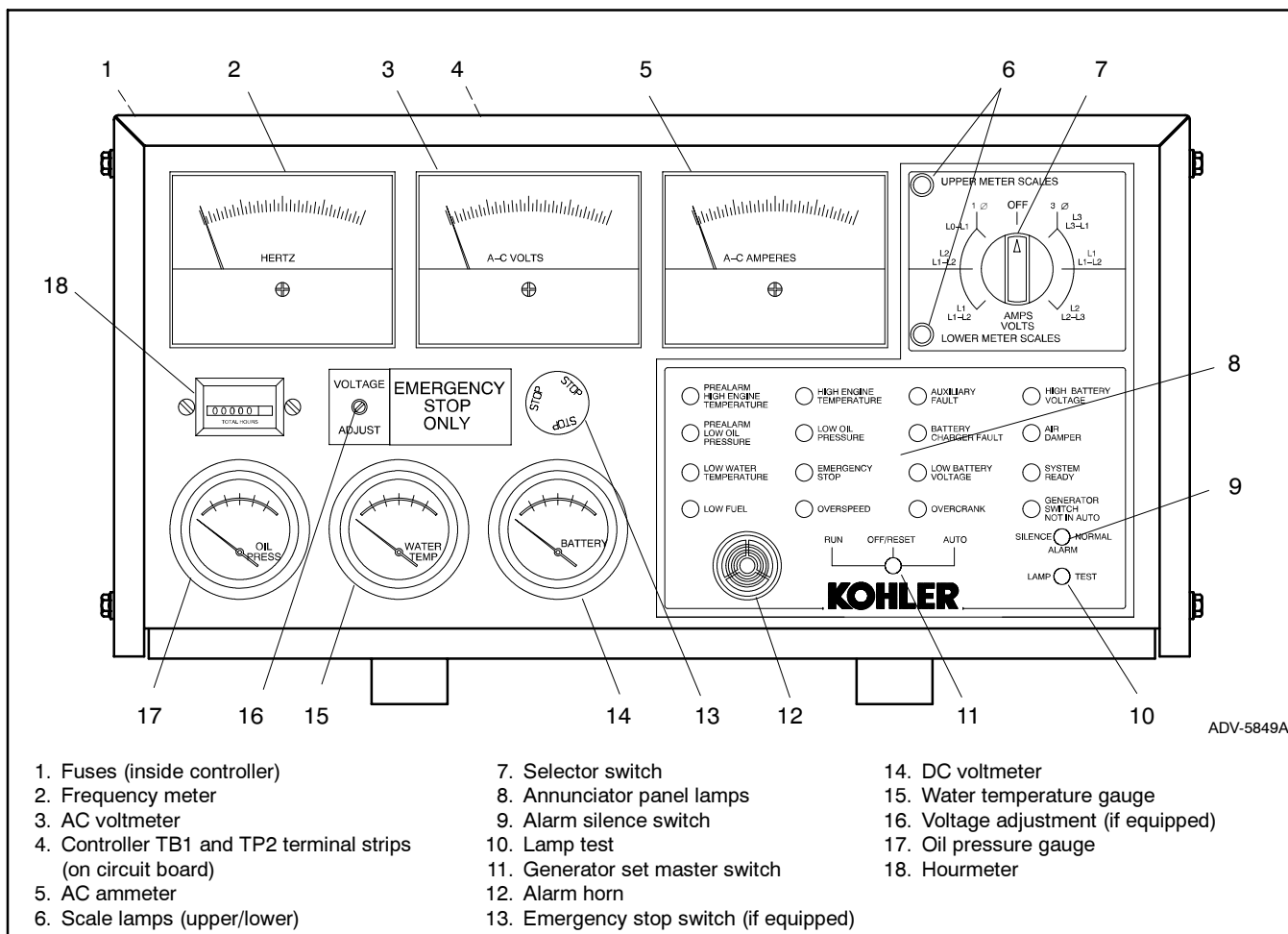

**Figure 1-1** 16-Light Decision-Maker 3+™ Controller

The 16-light controller with communications has a new circuit board GM28725 that is different in appearance and has additional functions from the earlier versions but is a **direct replacement for earlier version circuit boards including A-336415**. Features of the new circuit board include the following items:

- Red circuit board, previous versions are green.
- Terminal strips (TB1, TB2, and TB3).
- SW1 DIP switch (8 switches).
- Communication connector P21 for Modbus® to download new application program software or to connect the remote serial annunciator using RS-485 communications. Requires RS-485 to RS-232 converter for downloading application program.
- Communication connector P22 for J1939 engine communication.

**New Application Program Software.** Contact your local authorized distributor for application program updates when instructed to do so during troubleshooting and/or when adding specific accessories. Refer to TT-1285 Program Loader Software instruction for additional download information.

## 1.2.1 Annunciator Panel Lamps

Figure 1-2 lists the annunciator lamps included on each controller and describes the lamp functions.

Lamp	Description
Air damper	This light is not used on current standard products.
Auxiliary fault	Flashes or lights upon fault detection. Figure 1-3 describes auxiliary fault conditions.
High engine temperature	Lights if the engine has shut down because of high engine temperature. The shutdown occurs 5 seconds after the engine reaches temperature shutdown range.
Low oil pressure	Lamp lights if the generator set shuts down because of insufficient oil pressure. The shutdown occurs 5 seconds after the engine reaches temperature shutdown range.
Overspeed	Lamp lights if the generator set shuts down because the governed frequency on 50/60 Hz models exceeds 60/70 Hz.
Overcrank	Cranking stops and the lamp lights if the engine does not start after 30 seconds of continuous cranking or 75 seconds of cyclic cranking. See Section 2.3.1, Normal Operation. <b>Note:</b> The engine ECM may limit the crank cycle even if the controller is set to a longer time period. Cranking stops and the overcrank lamp lights after 25 seconds if the starter or engine does not turn (locked rotor). The overcrank lamp flashes if the speed sensor signal is absent for longer than one second.
Low water temperature	Lights if water temperature falls below the minimum preset temperature. This lamp may require an optional prealarm sender kit in order to function.
Battery charger fault	Lights if the battery charger malfunctions. This lamp requires an optional battery charger.
Emergency stop	Lights and the generator set shuts down if the optional emergency stop switch is energized either locally or from a remote location. The local emergency stop switch is standard on selected models.
Generator switch not in auto	Lights when the generator set master switch is in the RUN or OFF/RESET position.
High battery voltage	Lights if the battery voltage rises above preset level. An optional battery charger is required for the lamp to function.
Low battery voltage	Lights if the battery voltage drops below a preset level. This lamp requires an optional battery charger in order for the lamp to function.
Low fuel warning	Lights if the fuel level in tank approaches empty. This lamp requires a low fuel sensor in the fuel tank in order to function. On gas-fueled systems, this lamp lights if the gas line pressure drops below a preset level.
Prealarm high engine temperature	Lights if the engine temperature approaches the shutdown range. This lamp may require an optional prealarm sender kit.
Prealarm low oil pressure	Lights if the engine oil pressure approaches the shutdown range. This lamp may require an optional prealarm sender kit in order to function.
System ready	Lights when the generator set master switch is in the AUTO position and the system senses no faults. Indicates that the generator set is ready for operation.

**Figure 1-2** Annunciator Panel Lamps

## 1.2.2 Auxiliary Fault Lamp

The auxiliary fault lamp flashes or lights continuously to indicate different conditions. Figure 1-3 describes the auxiliary fault lamp conditions.

Generator Condition	Lamp Illumination	
	Flashing	Continuous
<b>Auxiliary Delay Shutdown.</b> Lamp lights and the engine shuts down 5 seconds after high oil temperature (P1-13), low coolant level (P1-10 [2-wire sender] or P1-14 [3-wire switch]), or auxiliary delay shutdown (P1-15) faults (if equipped) occur. These fault conditions are inhibited during the first 30 seconds after crank disconnect.		X
<b>Auxiliary Immediate Shutdown.</b> Lamp lights and the engine shuts down if activated by customer-supplied sensing devices connected to auxiliary immediate shutdown ports (P1-17 and P1-18).		X
<b>Emergency Stop Switch Reset.</b> Lamp lights if the optional emergency stop switch is reset while the generator set master switch is in the AUTO or RUN position. Place the generator set master switch in the OFF/RESET position to clear this fault.		X
<b>Low Fuel Shutdown (125RZG only).</b> Lamp lights and the engine shuts down if activated by the low fuel pressure shutdown switch connected to the <b>Auxiliary Immediate Shutdown</b> port P1-17. Place the generator set master switch in the OFF/RESET position to clear this fault.		X
<b>No AC Output.</b> Lamp flashes if the controller senses no AC output with the unit running (except during first 10 seconds after startup). When the controller senses AC output, the flashing stops and the lamp is unlit. Does not require manual reset.	X	
<b>Overvoltage Shutdown.</b> Lamp lights and the engine shuts down immediately if an overvoltage condition arises (if equipped with overvoltage shutdown kit).		X
<b>Underfrequency Shutdown.</b> Lamp lights and the engine shuts down if the engine speed drops below 5% of the nominal engine speed (1710 for 1800 rpm or 1425 for 1500 rpm) for a continuous 60-second period.		X

Figure 1-3 Auxiliary Fault Lamp Operation

## 1.2.3 Fuses

The fuses listed in Figure 1-4 protect the generator set circuitry.

Fuse	Description
F1	3-amp remote annunciator fuse protects the dry contact kit (if equipped).
F2	3-amp controller fuse protects the controller circuit board, speed sensor, and lamp circuit board.
F3	15-amp engine and accessories fuse protects engine/starting circuitry and accessories.

Figure 1-4 Controller Fuses

## 1.2.4 Analog Meters and Gauges

Figure 1-5 describes the meters and gauges located on microprocessor controllers.

Name	Description
AC voltmeter	Meter displays the AC output voltage. Use the selector switch to choose the output lead circuits.
AC ammeter	Meter displays the AC output amperage. Use the selector switch to choose the phase currents.
DC voltmeter	Meter displays the voltage of the starting battery(ies).
Frequency meter	Meter displays the frequency (Hz) of the generator set output.
Hourmeter	Hourmeter records the generator set total operating hours for reference in maintenance scheduling.
Oil pressure gauge	Gauge measures the engine oil pressure.
Scale lamps (upper/lower)	Lamps indicate which AC voltmeter and/or ammeter scales to read.
Water temperature gauge	Gauge displays the engine coolant temperature.

Figure 1-5 Analog Meters and Gauges

## 1.2.5 Switches and Controls

Figure 1-6 describes the switches and controls located on microprocessor controllers.

Name	Description
Alarm horn	Horn sounds if any fault or prealarm condition exists (except emergency stop, battery charger fault, high battery voltage, or low battery voltage). Place the generator set master switch in the AUTO position before silencing the alarm horn. See controller resetting procedure in Section 2.3.5, Controller Resetting After a Fault Shutdown.
Alarm silence switch	Switch silences the alarm during service. Place the generator set master switch in the AUTO position before silencing the alarm horn. To avoid reactivating the alarm horn, restore all alarm horn switches (controller, remote annunciator, and audiovisual alarm) to their normal positions after correcting the fault. See controller resetting procedure in Section 2.3.5, Controller Resetting After a Fault Shutdown.
Emergency stop switch	Switch (if equipped) immediately shuts down the generator set in emergency situations. Reset the emergency stop switch after shutdown by pulling the knob slightly outward. Use the emergency stop switch for emergency shutdowns only. Use the generator set master switch for normal shutdowns. The local emergency stop switch is standard on selected generator sets.
Generator set master switch	Switch functions as the controller reset and generator set operation switch. Refer to Section 2.3.1, Normal Operation, Section 2.3.2, Prime Power Mode Operation, and Section 2.3.5, Controller Resetting After a Fault Shutdown.
Lamp test switch	Switch displays the controller indicator lamps.
Selector switch	Switch selects the generator set output circuits to measure. When switched to a position with three circuit labels, the meters display the amperage on the lead shown in the upper label and the voltage between the two leads shown in the lower label. The AC ammeter and voltmeter function only with the switch in the ON position.
Voltage adjustment control, if equipped	Control fine tunes ( $\pm 5\%$ ) the generator set output voltage. Used with 20–400 kW permanent magnet/wound field alternator models only. The voltage adjustment on 350–2000 kW pilot-excited models is located in the generator junction box.

**Figure 1-6** Switches and Controls

## 1.2.6 Terminal Strips

Two terminal strips are mounted on the controller circuit board. See Figure 1-7 and Figure 1-8. Refer to Section 2.3.2, Prime Power Mode Operation, for information on enabling prime power mode.

Terminal Strip	Description
TB1/TB3	Terminal strip for connecting generator set accessories such as an emergency stop switch, a remote start/stop switch, audiovisual alarms, etc. Refer to the wiring diagrams for information on connecting accessories to the TB1 terminal strip.
TB2	Terminal strip for selecting the remote start/stop switch inputs and prime power mode.
P3/P7	Communication module connection for remote serial annunciator (RSA) or network communication.
P21	RS-485 communication connection for Modbus® to download new application program software or for connecting the remote serial annunciator.
P22	CAN (engine) communication connection.

**Figure 1-7** Controller Terminal Strips/Connections

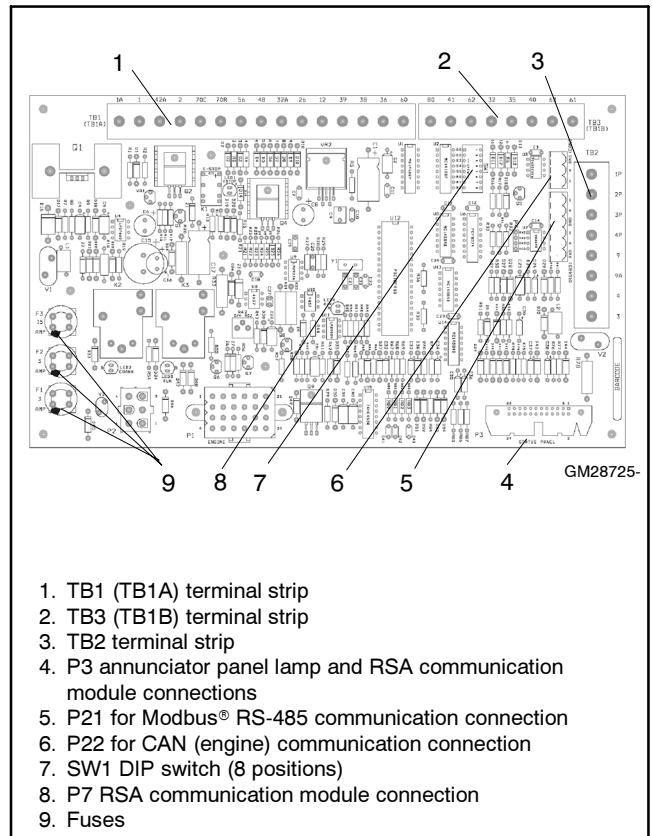

**Figure 1-8** Controller DIP Switches

Modbus® is a registered trademark of Schneider Electric.

## 1.2.7 DIP Switches

The controller circuit board contains eight DIP switches, see Figure 1-9.

DIP Switch	Description	Switch Position	
		Open	Closed
1	Overspeed selection	60 Hz	70 Hz
2	Temperature Cooldown Enable	Cooldown Disabled	Cooldown Functional
3	Crank Mode Selection	Cyclic	Continuous
4	Engine Comm. Setting	See selections for DIP switch 4 and DIP switch 5 below	
5	Engine Comm. Setting		
6	Modbus® Address Bit 0	Value = 0	Value = 2
7	Modbus® Address Bit 1	Value = 0	Value = 4
8	Modbus® Address Bit 2	Value = 0	Value = 8
4	No ECM	Open	
5		Open	
4	MDEC Comm.	Closed	
5	Isochronous	Open	
4	J1939 Communication	Open	
5		Closed	
4	MDEC Comm.	Closed	
5	Governor (VSG)	Closed	

Figure 1-9 DIP Switch Functions

**Note:** After setting DIP switches to the generator set application, be sure to *power down* and then *power up* the controller (disconnect the battery and then reconnect the battery of the generator set) or use the prime power switch, if equipped. The controller will NOT acknowledge the DIP switch change until after generator set controller is *powered up*.

Push down the end of the DIP switch near the OPEN label to open the switch, or push down the other end to close it. See Figure 1-10.

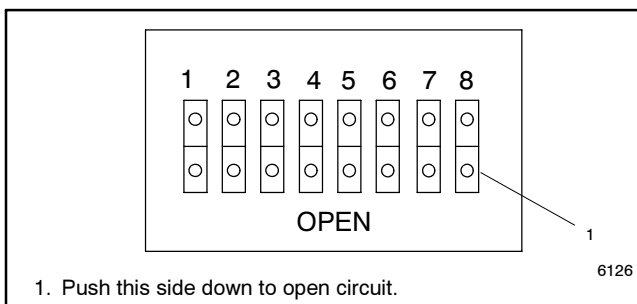

Figure 1-10 DIP Switch Open Position

Typically, the factory default settings have all the DIP switches in the closed position except the crank mode selection switch SW3 which is open for cyclic cranking. The overspeed selection switch SW1 is open on 50 Hz units. Be sure to select the correct DIP switch configuration for each generator set application.

**Overspeed Frequency (DIP Switch 1).** The generator set overspeed frequency is set using DIP switch 1. Select 70 Hz for 60 Hz voltages and 60 Hz for 50 Hz voltages.

**Temperature Cooldown (DIP Switch 2).** The generator set will continue to run during a five-minute cooldown cycle or shut down immediately. The choice is made using DIP switch 2.

**Engine Cranking (DIP Switch 3).** The controller is factory-set for cyclic cranking. To change to the continuous cranking mode, use DIP switch 3.

**Engine Configuration (DIP Switches 4 and 5).** See Figure 1-9 for the DIP switch positions based on engine configurations regarding non-ECM, MDEC, and J1939 engine communication selections.

**Modbus® Address (DIP Switches 6-8).** Each Modbus® device requires a unique address. Address numbers are created using a binary number system with DIP switches 6-8. Figure 1-11 shows the DIP switch position for each address number.

Modbus® Address	DIP Switches		
	6 Value = 2	7 Value = 4	8 Value = 8
1	Open	Open	Open
3	Closed	Open	Open
5	Open	Closed	Open
7	Closed	Closed	Open
9	Open	Open	Closed
11	Closed	Open	Closed
13	Open	Closed	Closed
15	Closed	Closed	Closed

Figure 1-11 Modbus® Device Address

## 1.3 Expanded Decision-Maker 1 Controller

For identification of the expanded controller's indicators and controls and their functions, refer to Figure 1-12.

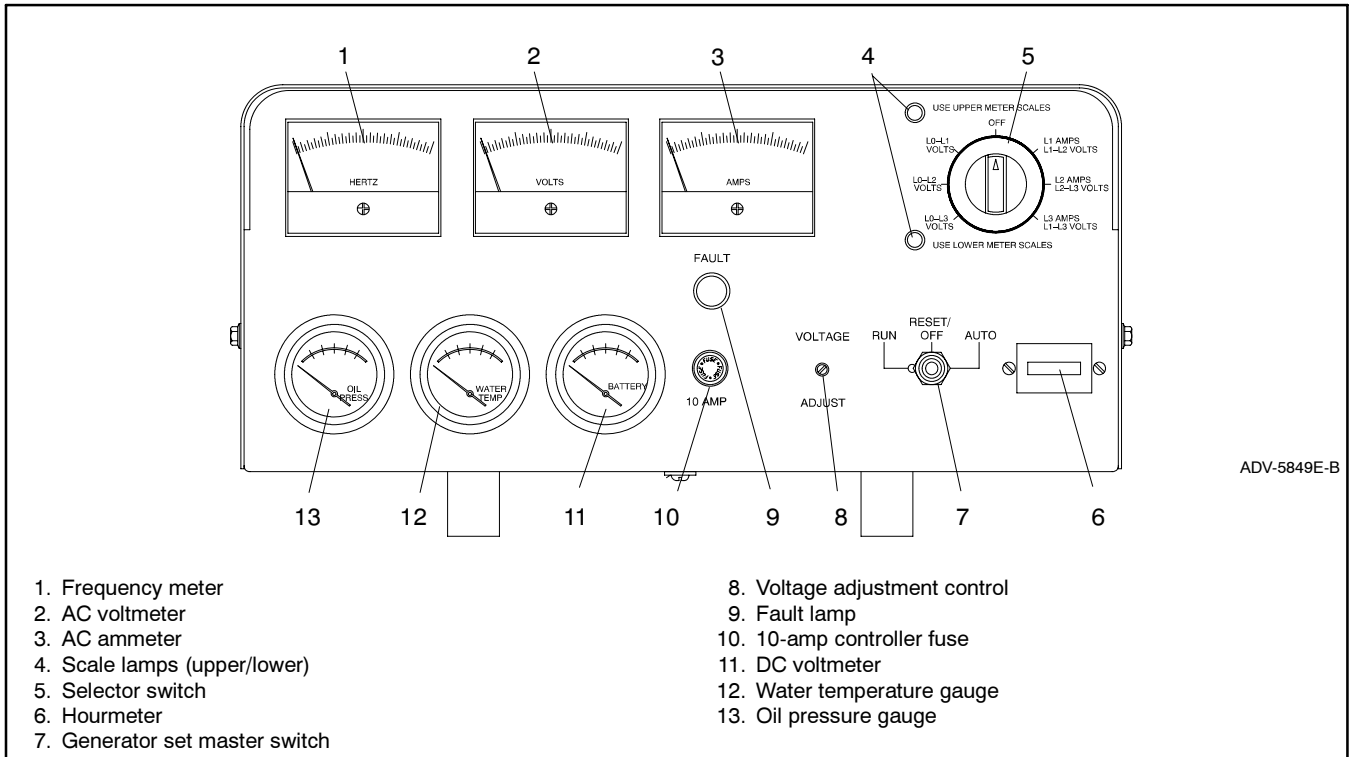

**Figure 1-12** Expanded Decision-Maker™ 1 Controller

Figure 1-13 and Figure 1-14 describe the controls and indicators located on the controller.

Item	Description
AC ammeter	Meter displays the AC output amperage. Use the selector switch to choose the phase currents.
AC voltmeter	Meter displays the AC output voltage. Use the selector switch to choose the output lead circuits.
DC voltmeter	Meter displays the voltage of the starting battery(ies).
Fault lamp	Lamp illuminates during engine shutdown if the engine shuts down because of one of the following faults: high engine temperature, low water level, low oil pressure, overcrank, or overspeed. See Section 2.4.3, Fault Shutdowns, for additional shutdown information.
Frequency meter	Meter displays the frequency (Hz) of the generator set output.
Generator set master switch	Switch functions as the controller reset and generator set operation switch.

**Figure 1-13** Controls and Indicators

Item	Description
Hourmeter	Hourmeter records the generator set total operating hours for reference in maintenance scheduling.
Oil pressure gauge	Gauge displays the engine oil pressure.
Scale lamps (upper/lower)	Lamps indicate which AC voltmeter and/or ammeter scales to read.
Selector switch	Switch selects the generator set output circuits to measure. When switched to a position with three circuit labels, the meters display the amperage on the lead shown in the upper label and the voltage between the two leads shown in the lower label. The AC ammeter and voltmeter function only with the switch in the ON position.
Voltage adjustment control	Control fine tunes ( $\pm 5\%$ ) the generator set output voltage.
Water temperature gauge	Gauge displays the engine coolant temperature.
10-amp controller fuse	Fuse protects the controller circuitry from short circuits and overloads.

**Figure 1-14** Controls and Indicators, continued



### 2.1 Prestart Checklist

To ensure continued satisfactory operation, perform the following checks or inspections before or at each startup, as designated, and at the intervals specified in the service schedule. In addition, some checks require verification after the unit starts.

**Air Cleaner.** Check for a clean and installed air cleaner element to prevent unfiltered air from entering the engine.

**Battery.** Check for tight battery connections. Consult the battery manufacturer's instructions regarding battery care and maintenance.

**Coolant Level.** Check the coolant level according to the cooling system maintenance information.

**Note: Block heater damage.** The block heater will fail if the energized heater element is not immersed in coolant. Fill the cooling system before turning on the block heater. Run the engine until it is warm, and refill the radiator to purge the air from the system before energizing the block heater.

**Drive Belts.** Check the belt condition and tension of the radiator fan, water pump, and battery charging alternator belt(s).

**Exhaust System.** Check for exhaust leaks and blockages. Check the silencer and piping condition and check for tight exhaust system connections.

Inspect the exhaust system components (exhaust manifold, exhaust line, flexible exhaust, clamps, silencer, and outlet pipe) for cracks, leaks, and corrosion.

- Check for corroded or broken metal parts and replace them as needed.
- Check for loose, corroded, or missing clamps and hangers. Tighten or replace the exhaust clamps and/or hangers as needed.
- Check that the exhaust outlet is unobstructed.
- Visually inspect for exhaust leaks (*blowby*). Check for carbon or soot residue on exhaust components. Carbon and soot residue indicates an exhaust leak. Seal leaks as needed.

**Fuel Level.** Check the fuel level and fill the tank(s) regularly to ensure adequate fuel supply.

**Ignition System.** Ensure that the ends of all spark plug wires are properly seated onto the coil/distributor and the spark plug.

**Lamp Test.** Press the lamp test button, if equipped, to verify that all controller LEDs illuminate.

**Oil Level.** Maintain the oil level at or near, not over, the full mark on the dipstick. Keep the oil level in the mechanical governor, if equipped, at or near the full level.

**Operating Area.** Check for obstructions that could block the flow of cooling air. Keep the air intake area clean. Do not leave rags, tools, or debris on or near the generator set.

### 2.2 Generator Set Exercising

Operate the generator set under load once each week for one hour. Perform the exercise in the presence of an operator if the generator set does not have a programmed exercise mode or an automatic transfer switch with an exercise option.

During the exercise period apply a minimum of 35% load based on the nameplate standby rating, unless otherwise instructed in the engine operation manual.

The operator should perform all of the prestart checks before starting the exercise procedure. Start the generator set according to the starting procedure in the controller section of this manual. While the generator set is operating, listen for a smooth-running engine and visually inspect the generator set for fluid or exhaust leaks.

### 2.3 16-Light Controller Features

#### 2.3.1 Normal Operation

**Local Starting.** Move the generator set master switch to the RUN position to start the generator set at the controller.

**Note:** The alarm horn sounds and the Not in Auto lamp lights when the generator set master switch is not in the AUTO position.

**Note:** The transient start/stop function of the 16-light controller prevents accidental cranking of the rotating engine. If the generator set master switch is momentarily placed in the OFF/RESET position and then is returned to the RUN position, the generator set slows to 750 rpm (25 Hz) and recranks before returning to rated speed.

**Automatic Starting.** Move the generator set master switch to the AUTO position to allow startup by an automatic transfer switch or a remote start/stop switch. Refer to the wiring diagrams for remote switch connection information.

The engine cranks up to 30 seconds continuously or 75 seconds cyclically (crank 15 seconds, rest 15 seconds, crank 15 seconds, etc.) before shutting down on an overcrank fault.

**Note:** The engine ECM may limit the crank cycle even if the controller is set to a longer time period.

Select the cyclic or continuous cranking mode on the controller circuit board. See Section 1.2.7 DIP switches.

**Stopping.** Run the generator set without load for 5 minutes to ensure adequate engine cooldown. To stop the generator set, place the generator set master switch in the OFF/RESET position and wait until the generator set stops completely.

**Note:** The generator set continues to run during a 5-minute cooldown cycle if a remote switch or automatic transfer switch signals the engine to stop.

**Note:** The controller circuit board DIP switches allow disabling the engine cooldown function.

### 2.3.2 Prime Power Mode Operation

The controller can operate in either the normal mode or the prime power mode. In prime power mode, the controller draws less current when the generator set master switch is in the OFF/RESET position, minimizing the battery drain. Use the prime power mode for installations that do not have a battery charger to help prevent discharging the battery when the generator set is not operating.

Moving the generator set master switch to the OFF/RESET position disables all controller functions. Moving the generator set master switch to the AUTO position restores controller functions.

**Enabling and Disabling the Prime Power Mode.** To enable the prime power mode, use jumpers to connect TB2-1P to TB2-2P, TB2-3P to TB2-4P, and TB2-3 to TB2-4. To deactivate the prime power mode, remove these jumpers. See Figure 1-7, Figure 1-8, and Figure 2-1.

Terminal	Purpose
1P	Prime power operation.
2P	Prime power operation.
3	Remote start ground. Connect transfer switch or remote start switch to TB2-3 and TB2-4.
3P	Prime power operation.
4	Remote start. Connect transfer switch or remote start switch to TB2-3 and TB2-4.
4P	Prime power operation.

**Figure 2-1** 16-Light Controller TB2 Terminal Strip

**Prime Power Starting.** The prime power mode provides local starting only at the controller. The AUTO position no longer functions as a remote start. When the generator set master switch is in the OFF/RESET position, the controller functions are inoperative. Move the generator set master switch to the AUTO position to start the generator set. Do not start the generator set with the master switch in the RUN position because the alarm horn will sound.

**Note:** Move the generator set master switch to the AUTO position to return controller functions to normal.

**Prime Power Stopping.** Move the generator set master switch to the OFF/RESET position to stop the generator set and power down the controller.

**Note:** The controller functions are inoperative when the generator set master switch is in the OFF/RESET position.

### 2.3.3 Emergency Stopping

Activate the controller emergency stop switch, if equipped, or the optional remote emergency stop switch for immediate shutdown.

Use the emergency stop switch(es) for emergency shutdowns only. Use the generator set master switch for normal shutdowns.

The unit shuts down and the controller emergency stop lamp lights if an operator activates either the local or remote emergency stop switch.

Use the following procedure to restart the generator set after shutdown by an emergency stop switch. Refer to Section 2.3.5, Controller Resetting After a Fault Shutdown, to restart the generator set following a fault shutdown.

### Emergency Stop Switch Resetting Procedure

1. Investigate the cause of the emergency stop and correct the circuit or wiring problem(s).
2. If the remote emergency stop switch was activated, reset the switch by replacing the glass piece. If the controller-mounted emergency stop switch (if equipped) was activated, reset the controller emergency stop switch by rotating the switch clockwise until it springs back to its original position.

**Note:** The controller auxiliary fault lamp lights if the generator set master switch is in the RUN or AUTO position during the resetting procedure.

3. Toggle the generator set master switch to the OFF/RESET position and then to the RUN or AUTO position to restart the generator set. The generator set does not crank until the resetting procedure is completed.

### 2.3.4 Fault Shutdowns

The generator set shuts down automatically under the fault conditions listed in Figure 2-2.

### 2.3.5 Controller Resetting After a Fault Shutdown

Use the following procedure to restart the generator set after a fault shutdown. Refer to Section 2.3.3, Emergency Stopping, to reset the generator set after an emergency stop.

1. Move the controller alarm horn switch to the SILENCE position. If equipped, the audiovisual annunciator alarm horn and lamp are activated. Move the audiovisual annunciator alarm switch to SILENCE to stop the alarm horn. The audiovisual annunciator lamp stays lit.
2. Disconnect the generator set from the load by using the line circuit breaker or the automatic transfer switch.

Fault	Description
High engine temperature	The high engine temperature shutdown shuts down the unit 5 seconds after a fault. The shutdown does not function during the first 30 seconds following startup. <b>Note:</b> The high temperature shutdown functions only when the coolant level is in the operating range.
Low coolant level, if equipped	The low coolant level shutdown shuts down the unit 5 seconds after the fault. The shutdown does not function during the first 30 seconds following startup.
Low oil pressure	The low oil pressure shutdown shuts down the unit 5 seconds after fault detection. The shutdown does not function during the first 30 seconds following startup. <b>Note:</b> The low oil pressure shutdown does not protect against low oil level. Check the oil level at the engine.
Overcrank	Overcrank shuts down the unit after 45 seconds of continuous cranking. Shutdown occurs after 75 seconds of cyclic cranking (crank 15 seconds, reset 15 seconds, crank 15 seconds, etc., for a total of 75 seconds). Shutdown occurs after 15 seconds if the engine or starter does not turn (locked rotor). <b>Note:</b> The controller has an automatic restart function. The generator set attempts to restart if the engine speed drops below 390 rpm (output frequency of 13 Hz). Continued low engine speed causes an overcrank fault condition.
Overspeed	Overspeed shuts down the unit immediately when governed frequency on 50/60 Hz models exceeds 60/70 Hz. <b>Note:</b> The controller circuit board DIP switches allow 50 Hz (60 Hz shutdown) or 60 Hz (70 Hz shutdown) selection.
Overvoltage, if equipped	Overvoltage shuts down the unit and lights the auxiliary lamp when voltage is at least 15% over the nominal voltage for longer than 2 seconds. <b>Note:</b> Overvoltage can damage sensitive equipment in less than 1 second. Provide separate overvoltage protection for online equipment requiring faster shutdowns.

Figure 2-2 Fault Shutdowns

3. Correct the cause of fault shutdown. See the Safety Precautions section of this manual before proceeding.
4. Start the generator set by moving the generator set master switch to the OFF/RESET position and then to the RUN position. If equipped, the audiovisual annunciator alarm horn sounds and lamp goes out.
5. Verify that the cause of the shutdown was corrected by test operating the generator set.
6. Reconnect the generator set to the load by using the line circuit breaker or the automatic transfer switch.

**Note:** Place the generator set master switch in the AUTO position before silencing the alarm horn.

7. Move the generator set master switch to the AUTO position for startup by remote transfer switch or remote start/stop switch. If equipped, move the audiovisual annunciator alarm switch to NORMAL.
8. Move the controller alarm horn switch to the NORMAL position.

## 2.4 Expanded Decision-Maker 1 Controller

### 2.4.1 Generator Set Starting

**Local Starting.** Move the generator set to the RUN position to immediately start the generator set.

**Automatic Starting.** Move the generator set master switch to the AUTO position to allow startup by the automatic transfer switch or the remote start/stop switch connected to controller terminals TB1-3 and TB1-4.

**Note:** The controller allows up to 30 seconds of continuous cranking before overcrank shutdown occurs.

**Note:** The engine ECM may limit the crank cycle even if the controller is set to a longer time period.

### 2.4.2 Generator Set Stopping

#### Local Stopping

1. Run the generator set at no load for 5 minutes to ensure adequate engine cooldown.
2. Move the generator set master switch to the OFF/RESET position. The engine stops.

#### Automatic Stopping

1. The automatic transfer switch (ATS) or other device disconnects the load from the generator set.
2. The generator set continues to run for a preset time if the ATS is equipped with an engine cooldown time delay.
3. The ATS opens the connection between controller terminals TB1-3 and TB1-4. The generator set shuts down if the generator set master switch is in the AUTO position.

### 2.4.3 Fault Shutdowns

The generator set shuts down automatically under the fault conditions shown in Figure 2-3 and cannot be restarted until the fault condition is corrected. Reset the controller after a fault shutdown.

The fault lamp does not stay lit after the generator set shuts down on a fault condition.

### 2.4.4 Controller Resetting After a Fault Shutdown

Use the following procedure to restart the generator set after a fault shutdown.

1. Disconnect the generator set from the load using the line circuit breaker or automatic transfer switch. See the Safety Precautions at the beginning of this section before proceeding.
2. Correct the cause of the fault shutdown. See the Safety Precautions at the beginning of this section before proceeding.
3. Start the generator set by moving the generator set master switch to RESET/OFF and then to RUN.
4. Verify that the cause of the shutdown has been corrected by test operating the generator set.
5. Reconnect the generator set to the load using the line circuit breaker or automatic transfer switch.
6. Move the generator set master switch to the AUTO position for startup by remote transfer switch or remote start/stop switch.

Fault	Description
High engine temperature	Shutdown occurs 5 seconds after the fault. The high engine temperature shutdown does not function during the first 5 seconds after startup. <b>Note:</b> The high temperature shutdown functions only when the coolant level is in the operating range.
Low coolant level	Shutdown occurs 5 seconds after the fault. The low coolant level shutdown does not function during the first 5 seconds after startup.
Low oil pressure	Shutdown occurs 5 seconds after the fault. The low oil pressure shutdown does not function during the first 5 seconds after startup. <b>Note:</b> The low oil pressure shutdown does not protect against low oil level. Check the oil level at the engine.
Overcrank	Shutdown occurs after 30 seconds of continuous cranking. Shutdown occurs 30 seconds after startup if there is no AC output.
Overspeed	Shutdown occurs immediately when the governed frequency on the 50 and 60 Hz models exceeds 70 Hz.

**Figure 2-3** Fault Shutdowns

## Section 3 Scheduled Maintenance

Under normal operating conditions, the generator set's alternator requires no normal service. Consult the prestart checklist in Section 2.1 for a list of routine checks.

### 3.1 Alternator Service

When operating the generator set under dusty or dirty conditions, use dry compressed air to blow dust out of the alternator while the generator set is running. Direct the stream of air through openings in the generator set end bracket.

### 3.2 Engine Service

Perform engine service at the intervals specified in the engine manufacturer's service literature. Contact an authorized service distributor/dealer to obtain service literature.

**Note:** Have maintenance work, including battery service, performed by appropriately skilled and suitably trained maintenance personnel familiar with generator set operation and service.

---

**⚠ WARNING**

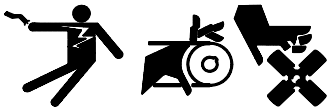

**Accidental starting. Can cause severe injury or death.**

Disconnect the battery cables before working on the generator set. Remove the negative (-) lead first when disconnecting the battery. Reconnect the negative (-) lead last when reconnecting the battery.

---

**Disabling the generator set. Accidental starting can cause severe injury or death.** Before working on the generator set or connected equipment, disable the generator set as follows: (1) Move the generator set master switch to the OFF position. (2) Disconnect the power to the battery charger. (3) Remove the battery cables, negative (-) lead first. Reconnect the negative (-) lead last when reconnecting the battery. Follow these precautions to prevent starting of the generator set by an automatic transfer switch, remote start/stop switch, or engine start command from a remote computer.

**⚠ WARNING**



**Hot engine and exhaust system. Can cause severe injury or death.**

Do not work on the generator set until it cools.

**Servicing the exhaust system. Hot parts can cause severe injury or death.** Do not touch hot engine parts. The engine and exhaust system components become extremely hot during operation.

**⚠ WARNING**



**Hazardous voltage. Moving parts. Can cause severe injury or death.**

Operate the generator set only when all guards and electrical enclosures are in place.

**Servicing the generator set when it is operating. Exposed moving parts can cause severe injury or death.** Keep hands, feet, hair, clothing, and test leads away from the belts and pulleys when the generator set is running. Replace guards, screens, and covers before operating the generator set.

### 3.3 Service Schedule

System—Component	Action					Interval
	Visually Inspect	Check	Change	Clean	Test	
<b>Fuel</b>						
Day tank level	X	X				Weekly
Flexible lines and connections	X		R			Weekly
Fuel level switch	X				X	Weekly
Main tank supply level		X				Weekly
Solenoid valve operation	X				X	Weekly
Transfer pump operation	X				X	Weekly
Water in system, remove		•		•		Weekly
Filter(s)			•			Quarterly
Gasoline supply			R			Six Months
Fuel piping	X					Yearly
Tank vents and return lines for obstructions		X				Yearly
<b>Lubrication</b>						
Oil level	•	•				Weekly
Crankcase breather	•		•			Quarterly
Change oil			•			First 50 Hours, Then Every 250 Hours
Replace filter(s)*			•			
<b>Cooling</b>						
Radiator fan bolt torque (1500-2800REOZDC with unit-mounted radiator)		X				Initially 8 Hours, Then Every 100 Hours
Air cleaner to room/enclosure		X				Weekly
Block heater operation		X				Weekly
Coolant level	•	•				Weekly
Flexible hoses and connectors	X	X				Weekly
Water pump(s)	•					Weekly
Fan and alternator belts	•	•	R			Monthly
Coolant temperature protection level					•	Six Months
Lubricate fan bearings (1200-2000 kW)	X	X				200 Hours or Six Months
Air ducts, louvers		X		X		Yearly
Coolant			•			Yearly
Heat exchanger				X		Yearly
Louver motors and controls	X			X	X	Yearly
Radiator exterior				X		Yearly
Water supply to heat exchanger		X				Yearly
<b>Exhaust Line</b>						
Drain condensate trap		X				Weekly
Leakage	X	X				Weekly
Insulation, fire hazards	X					Quarterly
Flexible connector(s)	X					Six Months
Excessive back pressure					X	Yearly
Hangers and supports	X					Yearly
<b>DC Electrical System</b>						
Battery charger operation, charge rate	X					Monthly
Battery electrolyte level		X				Monthly
Battery specific gravity, charge state					X	Monthly
Recharge after engine start		X				Monthly
Remove corrosion, clean and dry battery and rack	X			X		Monthly
Clean and tighten battery terminals	X	X				Quarterly
Tighten DC electrical connections		X				Six Months
<p>• Follow procedures and frequencies indicated in the engine manufacturer's maintenance manual. If not indicated, follow this service schedule. Some items may not apply to all generator sets.</p> <p>R Replace as necessary.</p> <p>X Action</p> <p>* Service more frequently if operated in dusty areas.</p>						

## Service Schedule, continued

System—Component	Action					Interval
	Visually Inspect	Check	Change	Clean	Test	
<b>AC Electrical System</b>						
Controller lamp test	X				R	Weekly
General inspection	X					Weekly
Circuit breakers, fuses†	X	X	R	X	X	Monthly
Wire abrasions where subject to motion	X	X				Quarterly
Safety and alarm operation		X			X	Six Months
Tighten control and power wiring connections		X				Yearly
Transfer switch main contacts†	X			X		Yearly
Voltage-sensing device/relay adjustment†		•			•	Yearly
Wire-cable insulation breakdown	X				X	3 Years or 500 Hours
<b>Engine and Mounting</b>						
General inspection	•					Weekly
Governor operation, lubricate moving parts	•	•				Monthly
Air cleaner service		•	•			Six Months
Choke, carburetor adjustment		•				Six Months
Governor oil (mechanical governor only)		•				Yearly
Ignition components	•			•		Yearly
Injector pump and injector flow rate, pressure, spray pattern		•			•	Yearly
Valve clearance		•				3 Years or 500 Hours
Bolt torque		•			•	3 Years or 500 Hours
<b>Remote Control System, etc.</b>						
Compartment condition	X			X		Weekly
Remote control					X	Monthly
Run generator set					X	Monthly
<b>Alternator</b>						
General inspection	X					Weekly
Rotor and stator	X			X		Yearly
Bearing condition	X	X	R			Yearly
Exciter	X	X		X		Yearly
Voltage regulator	X	X		X		Yearly
Measure and record resistance readings of windings with insulation tester (Megger®, with SCR assembly or rectifier disconnected)					X	Yearly
Blow dust out of alternator*	X			•		2 Years or 300 Hours
<b>General Condition of Equipment</b>						
Any condition of vibration, leakage, noise, temperature, or deterioration	X	X		X		Weekly
Ensure that system is set for automatic operation	X					Weekly
Interior of equipment room or outdoor weather housing	X			X		Weekly
<p>• Follow procedures and frequencies indicated in the engine manufacturer's maintenance manual. If not indicated, follow this service schedule. Some items may not apply to all generator sets.</p> <p>R Replace as necessary.</p> <p>X Action.</p> <p>* Service more frequently if operated in dusty areas.</p> <p>† Do not break manufacturer's seals or internally inspect these devices.</p>						

Megger® is a registered trademark of Biddle Instruments.

## 3.4 Alternator Bearing Service

Have an authorized service distributor/dealer perform service.

### 3.4.1 20–300 kW Models

Replace the end bracket bearing every 10,000 hours of operation in standby and prime power applications. Service the bearing more frequently if the annual inspection indicates excessive rotor end play or bearing damage. Replace the tolerance ring, if equipped, following end bracket removal. The sealed end bracket bearing requires no additional lubrication.

### 3.4.2 350–2000 kW Models with Single-Bearing Alternator

The alternator bearing requires lubrication at intervals specified in the generator set technical manual. Use Chevron SRI or equivalent antifriction, high-quality grease with a lubrication temperature range of  $-30^{\circ}$  to  $+175^{\circ}\text{C}$  ( $-22^{\circ}$  to  $+350^{\circ}\text{F}$ ).

### 3.4.3 1250–2000 kW Model with Two-Bearing Alternator

Refer to the generator set service manual for bearing maintenance information.

## 3.5 Diesel Fuel Systems

### 3.5.1 Bleeding Air from Fuel System

Bleed air from the fuel system after fuel system maintenance, such as replacing the fuel filter(s) using the hand prime pump kit, when equipped. The hand prime fuel pump eliminates the need for cranking the engine to bleed air from the fuel system.

**Note:** Bleed air from the fuel system according to the engine manufacturer's instructions. Trapped air in the fuel system causes difficult starting and/or erratic engine operation.

**Note:** Correct any fuel leaks encountered during the priming procedure.

1. Place the fuel valves in the fuel system prime position. Close the fuel valve located between the pipe tee and the engine. Open the fuel valves on each side of the fuel prime pump. See Figure 3-1.

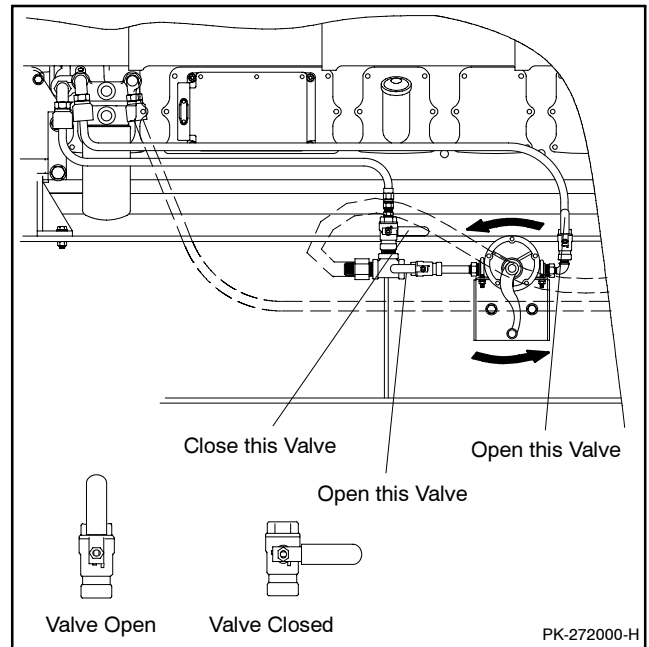

**Figure 3-1** Hand Prime Pump with Valve Positions for Fuel Priming (Generator Set Without a Fuel/Water Separator Shown)

**Note:** The illustration shows a generator set without a fuel/water separator. The valve location and position for a generator set equipped with a fuel/water separator is similar.

2. Loosen the bleed screw at the engine. Refer to the engine operation manual for location of the bleed screw(s). The bleed screw allows air to be expelled from the fuel system when the hand prime pump is operated.
3. Rotate hand prime pump handle counterclockwise until fuel flows from the bleed screw. Stop pumping.
4. Tighten the bleed screw. Wipe up any fuel leakage.
5. Place the fuel valves in the normal operation position. Open the fuel valve located between the pipe tee and the engine. Close the fuel valves on each side of the fuel prime pump.



### 3.5.2 Subbase Inner Fuel Tank Alarm

This kit provides for both audible and visual alarm from a location remote from the generator set if a leak is detected in the inner fuel tank of the double-wall subbase fuel tanks. See Figure 3-2. If the inner tank is leaking, a sensor installed in the outer tank sends an electrical signal to the alarm plate when the sensor becomes immersed in the fuel collecting in the outer tank. If a leak is detected, the alarm horn will sound and the fault lamp will light. The alarm horn is quieted by moving the alarm switch to the SILENCE position; the alarm lamp remains lit until the fault is corrected. See Figure 3-3 for troubleshooting information.

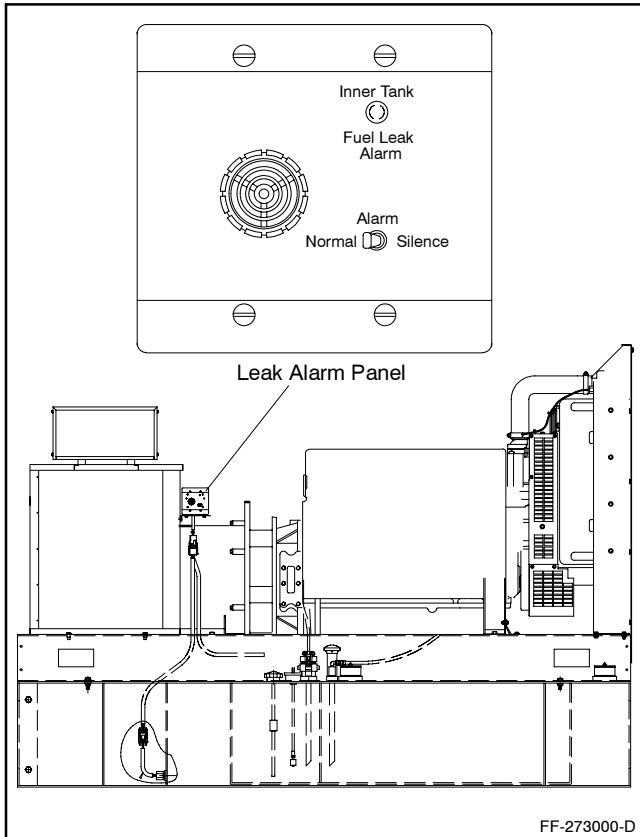

**Figure 3-2** Inner Fuel Tank Leak Alarm (20-300 kW Model Shown)

Alarm Switch Position	Float Switch Position	Observation
Normal	Open	The alarm horn and the lamp are not energized.
Normal	Closed	The alarm horn and lamp activate when a fuel leak occurs. If the alarm switch is moved to the silence position the lamp stays on until the fuel leak fault is corrected.
Silence	Open	The alarm horn sounds to alert the user that the alarm horn switch is not in the normal position and that the alarm horn will not sound should a fuel leak occur.

**Figure 3-3** Inner Fuel Tank Leak Alarm Troubleshooting

### Resetting Procedure

Use the following procedure to reset the alarm after a fault alarm.

1. Move alarm switch to the SILENCE position to stop alarm horn. Lamp will remain lit.
2. Disconnect generator set from load with line circuit breaker or automatic transfer switch.
3. Repair or replace the inner fuel tank.
4. Move generator set master switch to the OFF/RESET position and then to the RUN position for startup. Alarm horn sounds and lamp goes out.
5. Reconnect generator set to load via line circuit breaker or automatic transfer switch.
6. Move generator set master switch to the AUTO position for startup by remote transfer switch or remote start/stop switch. Move alarm switch to the NORMAL position.

## 3.6 Gas/Gasoline Fuel Systems

This section describes fuel systems that are not covered in the engine operation manual or engine service manual.

### 3.6.1 Gaseous Fuel System Concept

The gaseous fuel system uses a fuel valve with a solenoid to control the fuel flow to the fuel regulator. The generator set-mounted regulator reduces the fuel pressure as fuel passes to the carburetor. See Figure 3-4.

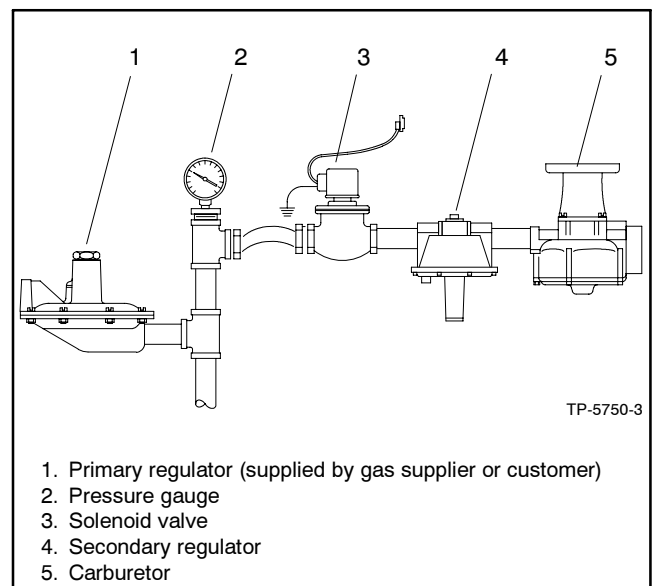

**Figure 3-4** Fuel Regulator and Valve, Typical

The carburetor/mixer controls the ratio of fuel to air under varying load and speed conditions. Because the carburetor receives fuel in a gaseous state, it does not have to vaporize the fuel. When switching from natural gas to LP gas or LP gas to natural gas, verify that the electronic governor maintains the rated engine speed (1800 rpm at 60 Hz or 1500 rpm at 50 Hz). If the engine speed is incorrect, refer to the generator set service manual for the governor adjustment procedure.

### 3.6.2 LP Liquid Withdrawal Fuel System Concept

With the LP liquid withdrawal fuel system, pressurized liquid LP fuel passes from the tank to a vaporizer. The vaporizer converts the liquid fuel to gas before sending it to the carburetor. The system also includes a fuel valve that shuts off the fuel flow when the engine stops. Contact an authorized service distributor/dealer for availability.

### 3.6.3 LP Gas/Natural Gas Conversion for Straight Gas Fuel System

Most models operate on either LP gas or natural gas fuel by performing the fuel conversion procedure. Some models require a different fuel kit when changing gas fuels. Consult your local generator set distributor/dealer for additional information.

Fuel conversion may decrease generator set output and affect exhaust emissions. Consult your local generator set distributor/dealer for additional information.

#### Fuel Conversion Procedure

When converting the generator set to operate with LP gas, remove the internal spring from the secondary regulator. Install the spring to operate the generator set on natural gas.

**Note:** Not all fuel regulators require spring and retainer removal for fuel conversion. A hang tag on the fuel regulator identifies the conversion procedure.

#### LP Fuel Conversion Procedure

Use the following steps to remove the internal spring from the fuel regulator:

1. Remove the fuel regulator cover plug. See Figure 3-5.

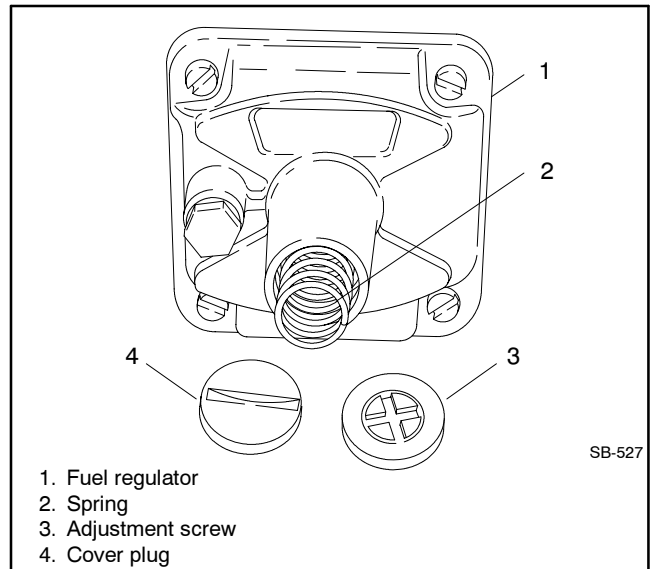

**Figure 3-5** Fuel Regulator, Typical

2. Remove the adjustment screw and spring from the fuel regulator. Save the adjustment screw and spring for possible conversion back to natural gas.
3. Reinstall the cover plug.

#### Natural Gas Fuel Conversion Procedure

Use the following steps to convert the generator set to natural gas:

1. Remove the fuel regulator cover plug. See Figure 3-5.
2. Replace the spring and adjustment screw.
3. Connect a manometer to check the fuel supply pressure on the carburetor side of the regulator downstream of any fuel system equipment accessories. The recommended fuel supply pressures are shown on the generator set spec sheet.
4. Adjust the fuel supply pressure with the generator set running at full load. Rotate the adjustment screw on the fuel regulator until the pressure indicated by the manometer matches the specified pressure. Use the lower pressure value if the generator set still provides good response and full power. Lower-than-specified pressures may result in poor response to load changes or lack of power.
5. Reinstall the cover plug.

### 3.6.4 Fuel System Changeover Kits

#### Automatic Changeover

A changeover fuel system kit provides automatic changeover from natural gas to LP gas vapor or from LP gas vapor to natural gas. The primary and backup fuels each have a secondary fuel regulator and a fuel valve. Typically, the primary fuel is natural gas; the backup fuel is LP gas vapor. When the generator set starts, the primary fuel valve opens and the backup fuel valve closes. The primary fuel line has a vacuum switch in series with a relay connected to the start/run circuit. When the primary fuel pressure drops below 0.6 kPa (1.4 oz./in.<sup>2</sup>) or 6.4 cm (2.5 in.) water column, a relay opens the backup fuel valve and closes the primary fuel valve. When the primary fuel pressure rises above 0.6 kPa (1.4 oz./in.<sup>2</sup>) or 6.4 cm (2.5 in.) water column, the generator set uses the primary fuel. Contact an authorized service distributor/dealer for kit availability.

#### Manual Changeover

A manual changeover fuel system allows manual changeover from gasoline to natural gas or LP gas, or from natural gas or LP gas to gasoline. Typically, the combination system uses gas as the primary, preferred fuel and gasoline in emergencies. If the primary fuel is unavailable (an empty fuel tank or fuel supply disruption), the system uses gasoline. A toggle switch on the generator set controls the fuel choice and energizes either a fuel solenoid and electric fuel pump for gasoline or a fuel valve for gas. Pull out the control cable for gasoline and push in the control cable for gas.

### 3.6.5 Carburetor Adjustment

Before adjusting the carburetor, verify that the engine compression and ignition system meet specifications. Do not adjust the carburetor to compensate for other engine disorders. If the engine speed is incorrect, adjust the electronic governor to achieve 1800 rpm (at 60 Hz) or 1500 rpm (at 50 Hz). Adjust the carburetor if governor adjustment alone does not result in the desired engine speed.

Adjusting the carburetor affects the engine fuel mixture. Routine carburetor adjustment is not necessary. However, if the carburetor is removed or tampered with, the carburetor may require adjustment to achieve optimum engine performance. Some engines have sealed carburetors that are not adjustable.

### Gasoline Carburetor Adjustment

Refer to the engine operation manual or engine service manual for gasoline carburetor adjustment information.

#### Gaseous Carburetor (Fuel Mixer) Adjustment Procedure

Use the following procedure to adjust the carburetor (fuel mixer).

1. Start the generator set and run it at approximately half load.
2. Adjust the engine fuel mixture screw (Figure 3-6) until the engine runs smoothly.
3. Apply varying loads and readjust the carburetor as necessary to achieve smooth engine performance at all load levels.
4. Stop the generator set.

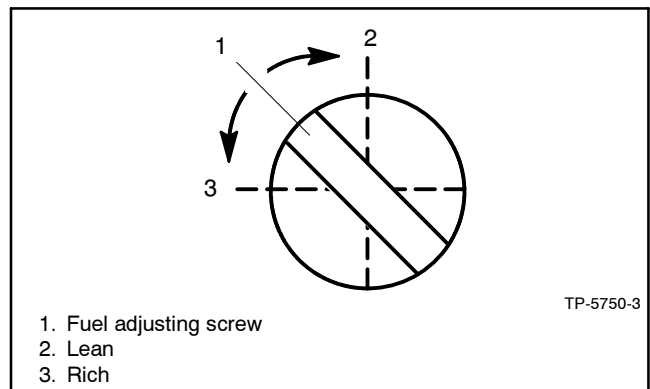

Figure 3-6 Fuel Mixture Adjustment, Typical

### 3.6.6 Fuel System Maintenance

#### Gasoline Models

Clean or replace the fuel filter at the specified interval. Service the filters more frequently if the engine runs roughly, as a clogged fuel filter can cause rough engine operation. Some models use a disposable inline fuel filter, which must be replaced. Other models have a fuel pump with an integral fuel filter that requires cleaning at the specified interval.

#### Gaseous Models

This fuel system requires no regular maintenance.

## 3.7 Cooling System

The cooling system maintenance information applies to radiator-cooled models and city-water-cooled (heat exchanger) models. The cooling systems function similarly even though they use different components. Radiator-cooled models have a radiator with a pressure cap and coolant recovery tank. City-water-cooled models have a heat exchanger and an expansion/surge tank with a pressure cap.

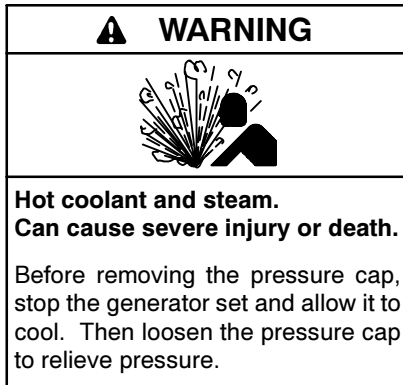

Allow the engine to cool. Release pressure from the cooling system before removing the pressure cap. To release pressure, cover the pressure cap with a thick cloth and then slowly turn the cap counterclockwise to the first stop. Remove the cap after pressure has been completely released and the engine has cooled. Check the coolant level at the tank if the generator set has a coolant recovery tank.

**Note: Engine damage.** Bleed the air from the cooling system to prevent overheating and subsequent engine damage.

**Note: Block heater damage.** The block heater will fail if the energized heater element is not immersed in coolant. Fill the cooling system before turning on the block heater. Run the engine until it is warm, and refill the radiator to purge the air from the system before energizing the block heater.

### 3.7.1 Coolant Level Check

Check the coolant level in the coolant recovery tank, if equipped. Maintain the coolant level between the high and low marks.

**Note:** Periodically check the coolant level by removing the pressure cap. Do not rely solely on the level in the coolant recovery tank. Add fresh coolant until the level is just below the overflow tube opening of the filler neck.

### 3.7.2 Cooling System Component Inspection

To prevent generator set shutdown or damage caused by overheating:

- Keep the cooling air inlets clean and unobstructed.
- Inspect the radiator's exterior for obstructions. Remove dirt and foreign material using a soft brush or cloth to avoid damaging the radiator fins.
- Check the hoses and connections for leaks. Replace any cracked, frayed, or spongy hoses.
- Check the condition and tension of the radiator fan and water pump belt(s). Follow the belt tension procedure in this manual and/or the engine operation manual.
- Check the pressure cap seal and replace a cracked or deteriorated cap. Remove dirt and other debris from the pressure cap and filler neck. The pressure cap raises the boiling point of the coolant, enabling higher operating temperatures. Replace a leaking pressure cap with one rated for the same pressure. The pressure cap rating usually appears on the pressure cap.

### 3.7.3 Cooling System Drainage Procedure

For optimum protection, drain, flush, and refill the cooling system at the intervals listed in the service schedule.

**Note:** Dispose of all waste materials (oil, fuel, coolant, filters, and gaskets) in an environmentally safe manner.

1. Deenergize the block heater, if equipped.
2. Remove the pressure cap to allow the entire system to drain and prevent air pockets from restricting coolant flow through the engine block.
3. Open the radiator and/or engine block coolant drain valve(s) and allow the system to drain.
4. If the inside of the radiator has mineral deposits or the used coolant contains dirt or grease, refer to Section 3.7.4, Cooling System Flush and Clean Procedure. If the cooling system does not have mineral deposits, go to Section 3.7.5, Cooling System Refilling Procedure.

### 3.7.4 Cooling System Flush and Clean Procedure

Use the instructions in the engine operation manual when available to flush and clean the cooling system. Otherwise, use the following procedure and the cooling system cleaner manufacturer's instructions.

1. Flush the cooling system with clean water.
2. If the inside of the radiator still has mineral deposits, use a radiator cleaner to remove the remaining deposits following the manufacturer's instructions.
3. Drain, clean, and flush the coolant recovery tank.

### 3.7.5 Cooling System Refilling Procedure

See the generator set spec sheet for coolant capacity.

**Note:** Do not add coolant to a hot engine. Adding coolant to a hot engine can cause the cylinder block or cylinder head to crack. Wait until the engine has cooled.

1. Remove the pressure cap.
2. Close radiator and/or engine block coolant drain valve(s) and tighten cooling system hose clamps.
3. Open the air-bleed petcocks, if equipped. Close the air-bleed petcocks when coolant begins to flow from them.
4. Add coolant additives or water pump lubricants according to the engine manufacturer's recommendations in the engine operation manual.
5. Fill the cooling system with the recommended coolant/antifreeze mixture of 50% ethylene glycol and 50% clean, softened water to inhibit rust/corrosion and prevent freezing.

**Note:** A coolant solution of 50% ethylene glycol provides freezing protection to  $-37^{\circ}\text{C}$  ( $-34^{\circ}\text{F}$ ) and overheating protection to  $129^{\circ}\text{C}$  ( $265^{\circ}\text{F}$ ). A coolant solution containing less than 50% ethylene glycol may not provide adequate freezing and overheating protection. A coolant solution containing more than 50% ethylene glycol can cause engine or component damage. Do not use alcohol or methanol antifreeze or mix them with the specified coolant. Refer to the engine operation manual for recommendations regarding the coolant mixture to use in extreme temperatures.

6. Replace the pressure cap.
7. Fill the coolant recovery tank to the low mark.
8. Operate the generator set until the thermostat opens when the upper cooling system hose warms.
9. Stop the engine and allow it to cool.
10. Remove the pressure cap.
11. Add coolant to bring the coolant level to just below the overflow tube opening of the filler neck.
12. Replace the pressure cap.
13. Maintain the coolant level in the coolant recovery tank between the high and low marks.

**Note:** Air pockets often form in the engine water jacket when the coolant system is refilled. Check the coolant level in the coolant recovery tank after each generator set operation and add coolant as necessary until the coolant level stabilizes. Then check the coolant at the interval specified in the service schedule.

14. Reenergize the block heater, if equipped.

## 3.8 Radiator Fan Bolt Retorque

*Adapted from Service Bulletin SB-683 12/07a.*

The radiator fan bolts must be initially checked after approximately 8 hours of operation and then rechecked after each 100 hours of operation. This scheduled service is required on all 1500-2800REOZDC unit-mounted radiator models using a 2743 mm (108 in.) diameter fan.

Perform the scheduled service steps in the order shown.

### Required Tools

- Socket wrench sets American Standard and Metric sizes
- Torque wrench, up to 203 Nm (150 ft. lb.)

### Procedure

1. Place the generator set master switch in the OFF/RESET position.
2. Disconnect the power to the battery charger, if equipped.

3. Disconnect the generator set engine starting battery(ies), negative (-) lead first.
4. Remove the fan guards, screens, and covers as necessary to access the radiator fan hardware.
5. Inspect the blades for cracks or other damage. Verify that all hardware is present. Replace as needed.
6. Retorque the (32 qty.) blade retention bolts/nuts to 136 Nm (100 ft. lb.). See Figure 3-7.

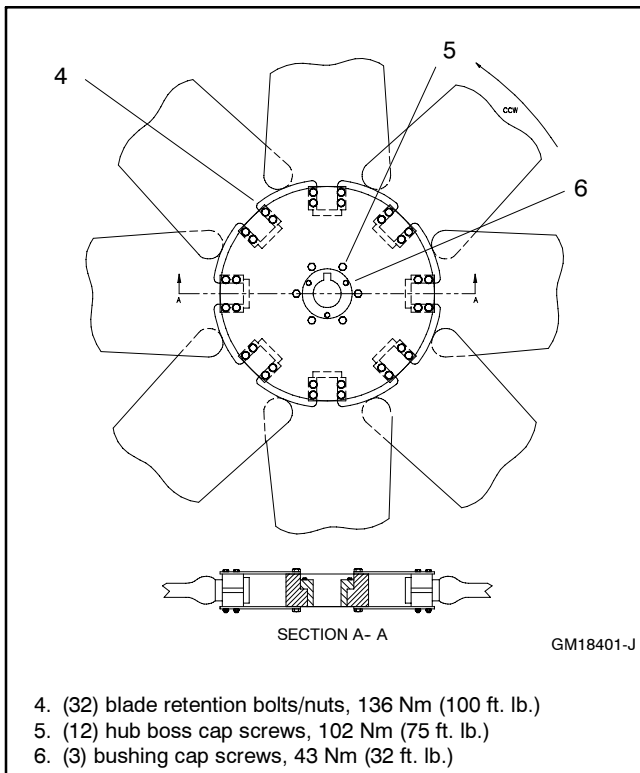

**Figure 3-7** Fan Hardware Location and Torque

7. Retorque the (12 qty.) hub boss cap screws to 102 Nm (75 ft. lb.). There are six screws on each side of the fan.
8. Retorque the (3 qty.) bushing cap screws to 43 Nm (32 ft. lb.).
9. Replace the fan guards, screens, and covers that were removed to access the radiator fan hardware.
10. Check that the generator set master switch is in the OFF position.
11. Reconnect the generator set engine starting battery, negative (-) lead last.
12. Reconnect power to the battery charger, if equipped.

13. Place the generator set master switch to the RUN position to start the generator set. Refer to the respective generator set operation manual as needed.
14. Listen and observe the fan operation.
15. **Immediately shut down the generator set if abnormal noise or fan assembly vibration is observed.** Correct the problem and go back to step 13.
16. After several minutes of generator set operation without abnormal noise or vibration, shut down the generator set by placing the generator set master switch to the OFF/RESET position.

### 3.9 Radiator Fan Bearing Lubrication

The following procedure applies only to 1200–2000 kW generator sets. Lubricate the radiator fan shaft and idler shaft bearings at every engine oil change to avoid bearing damage. Lubricate the bearings every 200 hours of operation when the generator set runs in ambient temperatures below 29°C (85°F) or when the generator set runs in a dusty and/or humid environment.

#### Lubrication and Drive Belt Adjustment Procedure

Lubricate the fan shaft and idler shaft bearings with a lithium-complex base, multi-purpose grease with antirust, antifoam, and extreme-pressure additives having a minimum dropping point of 204°C (400°F). Use Mobil Mobilith AW2 NLGI Grade 2 or equivalent.

1. Place the generator set master switch in the OFF/RESET position.
2. Disconnect the generator set engine starting battery(ies), negative (-) lead first, and disconnect power to the battery charger.
3. Remove the belt guards to expose the fan shaft and idler shaft bearings.
4. Inject grease into the two bearings on the fan shaft block and the two bearings on the idler shaft block using a grease gun until a 3–6 mm (0.13–0.25 in.) grease column shows at the bearing pressure relief port. See Figure 3-8.

**Note:** The fan shaft and idler shaft bearings have pressure relief ports to prevent bearing damage caused by overlubrication.

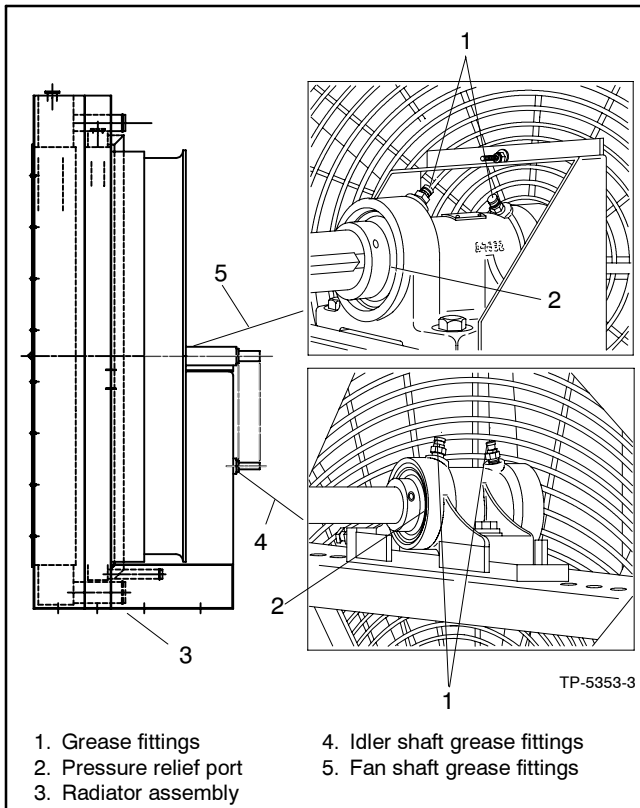

**Figure 3-8** Radiator Fan Bearings and Pressure Relief Ports, Typical

5. Remove excess grease from the bearing pressure relief ports.
6. Inspect the fan drive belt and replace if it is damaged or worn. Check the fan belt tension using a poly V-belt tension gauge and adjust the tension, if necessary. See Figure 3-9.

Generator Set Model	New Belt, N (lbf.)	Used Belt,* N (lbf.)
1200-2000 kW	2450-2890 (550-650)	1650-1910 (370-430)

\* A belt is considered used after 50 hours of service.

**Figure 3-9** Poly V-Belt Tension Specifications

7. Reinstall the belt guards using the original hardware.
8. Reconnect the generator set engine starting battery(ies), negative (-) lead last.
9. Test run the generator set for a few minutes and listen for belt noise (squeal) indicating a slipping belt. Stop the generator set.

If the belt slips after the belt tension procedure, clean the pulley surfaces and repeat the belt tension procedure. If slippage continues, replace the fan belt.

## 3.10 Battery

### **⚠ WARNING**



**Sulfuric acid in batteries.  
Can cause severe injury or death.**

Wear protective goggles and clothing. Battery acid may cause blindness and burn skin.

**Battery gases. Explosion can cause severe injury or death.** Battery gases can cause an explosion. Do not smoke or permit flames or sparks to occur near a battery at any time, particularly when it is charging. Do not dispose of a battery in a fire. To prevent burns and sparks that could cause an explosion, avoid touching the battery terminals with tools or other metal objects. Remove all jewelry before servicing the equipment. Discharge static electricity from your body before touching batteries by first touching a grounded metal surface away from the battery. To avoid sparks, do not disturb the battery charger connections while the battery is charging. Always turn the battery charger off before disconnecting the battery connections. Ventilate the compartments containing batteries to prevent accumulation of explosive gases.

**Battery short circuits. Explosion can cause severe injury or death.** Short circuits can cause bodily injury and/or equipment damage. Disconnect the battery before generator set installation or maintenance. Remove all jewelry before servicing the equipment. Use tools with insulated handles. Remove the negative (-) lead first when disconnecting the battery. Reconnect the negative (-) lead last when reconnecting the battery. Never connect the negative (-) battery cable to the positive (+) connection terminal of the starter solenoid. Do not test the battery condition by shorting the terminals together.

**Battery electrolyte is a diluted sulfuric acid. Battery acid can cause severe injury or death.** Battery acid can cause blindness and burn skin. Always wear splashproof safety goggles, rubber gloves, and boots when servicing the battery. Do not open a sealed battery or mutilate the battery case. If battery acid splashes in the eyes or on the skin, immediately flush the affected area for 15 minutes with large quantities of clean water. Seek immediate medical aid in the case of eye contact. Never add acid to a battery after placing the battery in service, as this may result in hazardous spattering of battery acid.

**Battery acid cleanup. Battery acid can cause severe injury or death.** Battery acid is electrically conductive and corrosive. Add 500 g (1 lb.) of bicarbonate of soda (baking soda) to a container with 4 L (1 gal.) of water and mix the neutralizing solution. Pour the neutralizing solution on the spilled battery acid and continue to add the neutralizing solution to the spilled battery acid until all evidence of a chemical reaction (foaming) has ceased. Flush the resulting liquid with water and dry the area.

Refer to this section for general battery information and maintenance. All generator set models use a negative ground with a 12-volt or 24-volt engine electrical system. Consult the generator set nameplate for the engine electrical system voltage. Consult the generator set spec sheet for battery capacity recommendations for replacement purposes. The wiring diagrams provide battery connection information. See Figure 3-10, Figure 3-11, and Figure 3-12 for typical battery connections, including multiple battery configurations.

After reconnecting the battery cables, coat the terminals with petroleum jelly, silicon grease, or other nonconductive grease.

**Note:** Some units require a reflective heat shield insulative sleeve on the battery cables and other wires that are fastened to the starter solenoid. This sleeve is a conductive material and must be secured approximately 25 mm (1 in.) away from the exposed cable terminal.

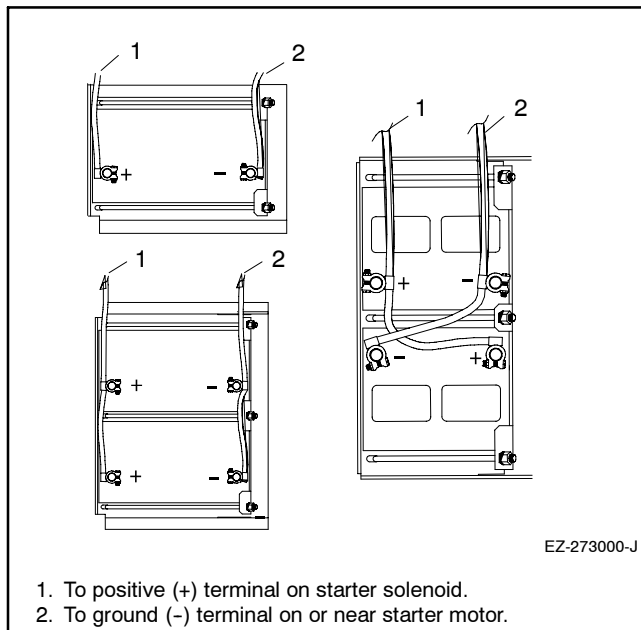

**Figure 3-10** 12-Volt Engine Electrical System Single Starter Motor Typical Battery Connection

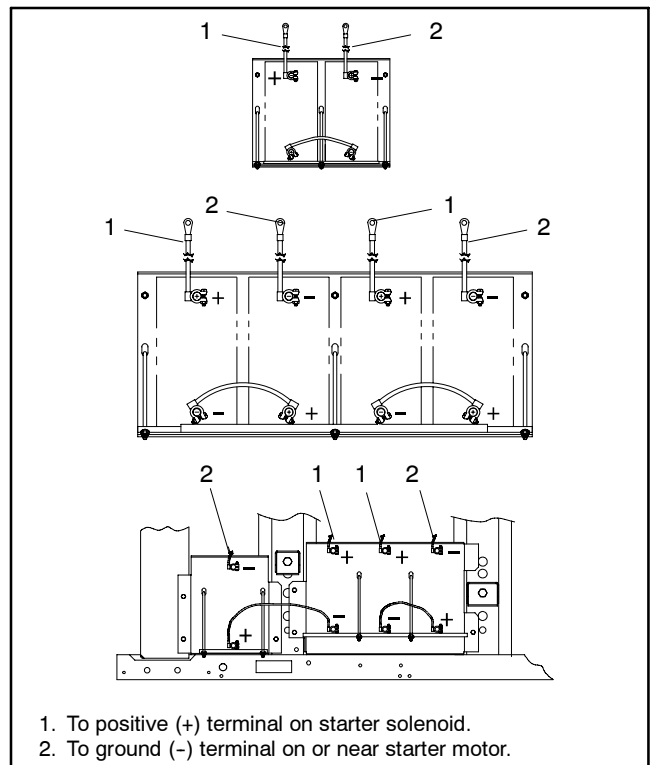

**Figure 3-11** 24-Volt Engine Electrical System Single Starter Motor Typical Battery Connection

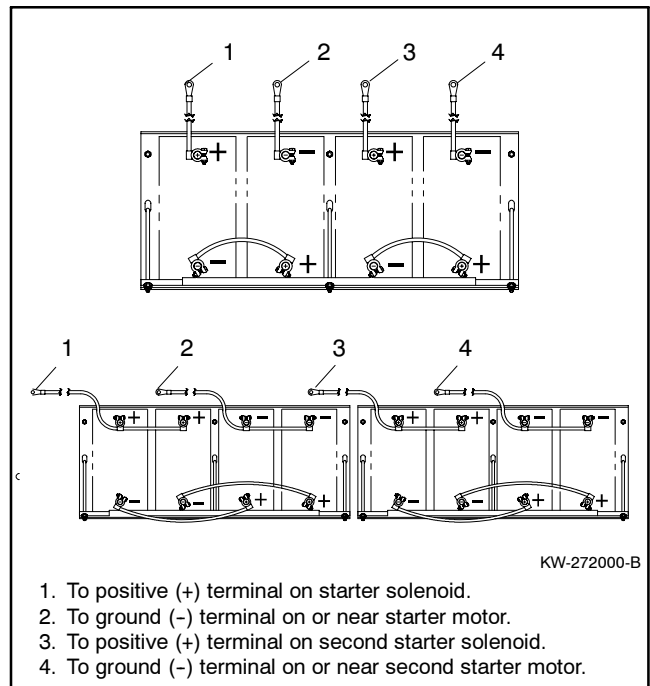

**Figure 3-12** 24-Volt Engine Electrical System Dual Starter Motors Typical Battery Connections



### 3.10.1 Cleaning

Clean the battery and cables and tighten the battery terminals according to the service schedule recommendations. Clean the battery by wiping it with a damp cloth. Keep electrical connections dry and tight.

If corrosion exists, disconnect the cables from the battery and remove the corrosion with a wire brush. Clean the battery and cables with a solution of baking soda and water. Do not allow the cleaning solution to enter battery cells. Flush the battery and cables with clean water and wipe the battery with a dry cloth.

### 3.10.2 Electrolyte Level Inspection

Check the electrolyte level and specific gravity of batteries that have filler caps. Maintenance-free batteries do not require electrolyte level checking or specific gravity testing.

Check the electrolyte level at the specified interval. Remove the filler caps and verify that the electrolyte level reaches the bottom of each filler hole. See Figure 3-13. Refill as necessary with distilled water or clean tap water. Do not add fresh electrolyte. Tighten the filler caps. After adding water during freezing temperatures, run the generator set 20–30 minutes to mix the electrolyte and the water to prevent battery damage from freezing.

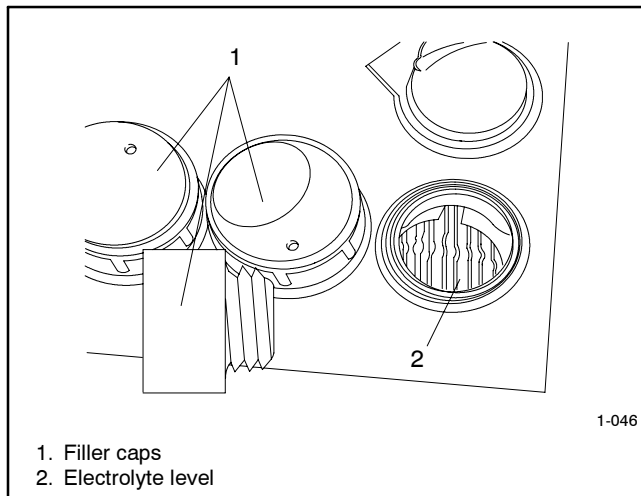

Figure 3-13 Battery Electrolyte Level Inspection

### 3.10.3 Specific Gravity Check

Use a battery hydrometer to check the specific gravity of the electrolyte in each battery cell of batteries with filler caps. Holding the hydrometer vertically, read the number on the glass bulb at the top of the electrolyte level or the number adjacent to the pointer. If the hydrometer used does not have a correction table, consult Figure 3-14.

Determine the specific gravity and electrolyte temperature of the battery cells. Locate the temperature in Figure 3-14 and correct the specific gravity by the amount shown. The battery is fully charged if the specific gravity is 1.260 at an electrolyte temperature of 26.7°C (80°F). Maintain the specific gravities between cells within ±0.01 of each other. Charge the battery if the specific gravity is below 1.215 at an electrolyte temperature of 26.7°C (80°F).

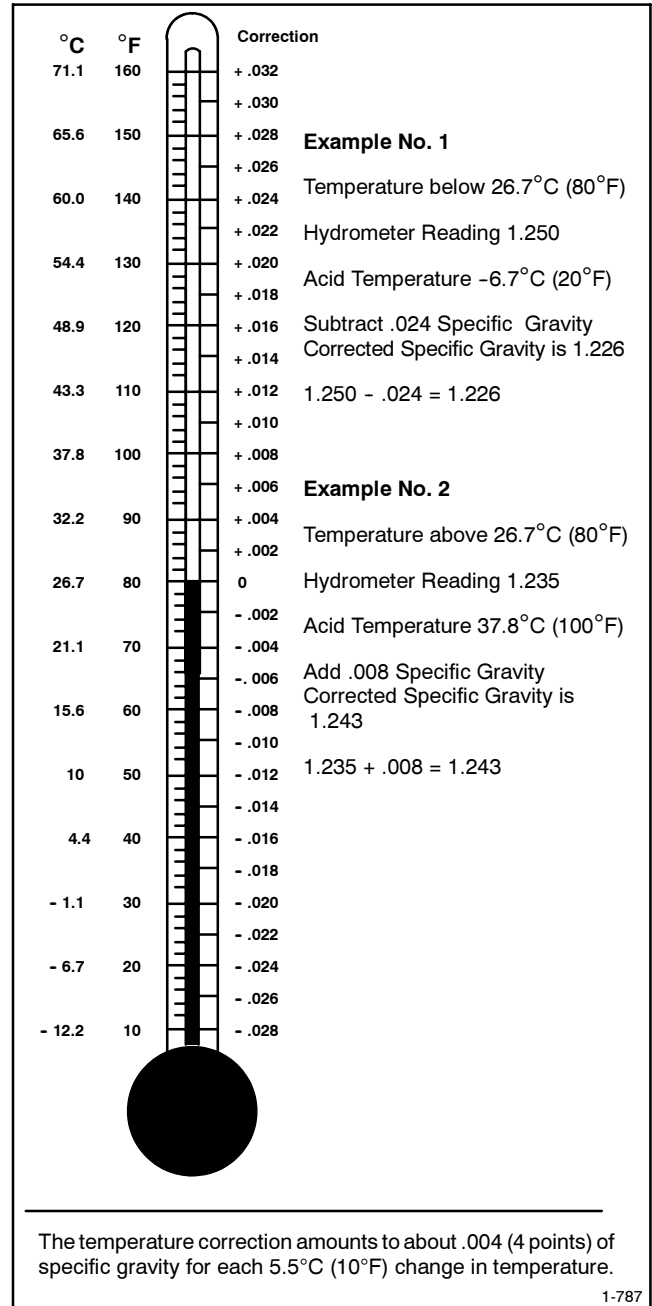

Figure 3-14 Specific Gravity Temperature Correction

**Note:** Some battery testers have four or five beads in a test tube. Draw electrolyte into the tube as with the battery hydrometer described in this section. Use the tester manufacturer's instructions. Figure 3-15 shows typical test results.

Number of Floating Beads	Battery Condition
5	Overcharged
4	Fully charged
3	A good charge
1 or 2	A low charge
0	A dead battery

**Figure 3-15** Bead-Type Test Interpretation

### 3.10.4 Charging

Use a battery charger to maintain a fully charged battery when the generator set is used in a standby application. The engine battery-charging alternator charges the battery only while the generator set is running.

**Note:** If the generator set is in a temporary prime power application in which the generator set has periods of inactivity, the controller circuitry may drain the battery. If there is no power source for a battery charger, place the controller in the prime power mode, if equipped, or disconnect the battery from the generator set.

## 3.11 Detroit Diesel Engine Control Systems

Some generator sets equipped with Detroit Diesel engines use a DDEC/MDEC system. Access the DDEC control box inside the generator set junction box to retrieve codes when performing routine maintenance or troubleshooting the engine.

**Note:** DDC/MTU engines with MDEC requires the following method:

- Use a personal computer software package available from the manufacturer with a translator to access stored codes. Follow the instructions provided with the software.

Use the following data for informational purposes only. Consult the engine literature for complete information regarding operation and troubleshooting. See List of Related Materials in the Introduction section. Contact an authorized service distributor/dealer for service or diagnostic equipment.

### 3.11.1 Features

The DDEC/MDEC system optimizes control of critical engine functions and protects against serious engine damage resulting from conditions such as the following:

- Low coolant level
- Low coolant pressure
- High coolant temperature
- Low oil pressure
- High oil temperature

The major components of the DDEC/MDEC system include the electronic control module (ECM) and engine sensors. The DDEC control box is located in the generator set junction box.

### 3.11.2 DDEC Engine Diagnostics

The DDEC engine protection system monitors engine sensors and electronic components and recognizes system malfunctions. Critical faults light the check engine (CEL) and stop engine (SEL) lamps on the control box. ECM memory software logs malfunction codes. Consult the engine operation manual or engine service manual to identify the stored failure code. See Figure 3-16 for the DDEC control box features.

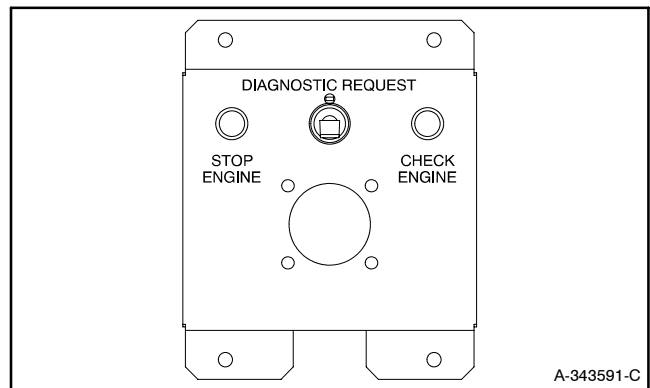

**Figure 3-16** DDEC Control Box

Access the stored codes in one of three ways:

- Place the switch in the DIAGNOSTIC REQUEST position. The CEL or SEL flashes to identify the failure.
- Use a hand-held diagnostic data reader (DDR). Place the switch in the DIAGNOSTIC DATA READER position. Plug the DDR into the control box. The DDR displays the stored failure codes.
- Use a personal computer software package available from the manufacturer with a translator to access stored codes. Follow the instructions provided with the software.

## Code Types

**Active code.** A code flashing on the SEL lamp indicates a fault currently exists.

**Inactive code.** A code flashing on the CEL lamp indicates a previous fault occurrence. The ECM memory stores inactive codes with time/date identification and the following information:

- First occurrence of each diagnostic code in engine operating hours.
- Last occurrence of each diagnostic code in engine operating hours.
- Total time in seconds that the diagnostic code was active.

## 3.12 Engine Control Systems

Some generator sets use an engine control system. Access the control box inside the generator set junction box to retrieve codes when performing routine maintenance or troubleshooting engine.

Use the following data for general informational purposes only. See the Engine Service Manual for complete information regarding operation and troubleshooting. Contact an authorized service distributor/dealer for service or diagnostic equipment.

### Engine Control Features

Engine control is an advanced-technology, electronic engine control system. The system optimizes control of critical engine functions and provides protection against serious engine damage.

The major components include the engine control module, engine sensors, and control box located in the generator set junction box.

See Figure 3-17 for the John Deere engine control box features.

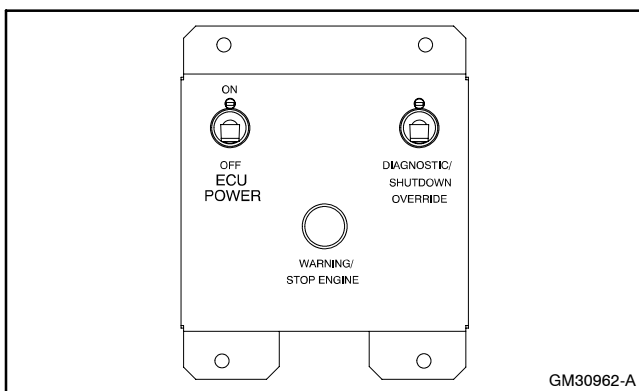

**Figure 3-17** John Deere Engine Control Box

See Figure 3-18 for the Kohler-branded D300, D350, D400, D450, and D500 engine control box features.

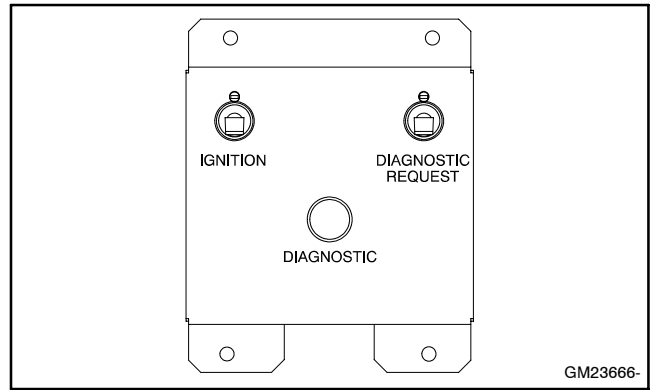

**Figure 3-18** Kohler-Branded Engine Control Box

## 3.13 Storage Procedure

Perform the following storage procedure before taking a generator set out of service for three months or longer. Follow the engine manufacturer's recommendations, if available, for fuel system and internal engine component storage.

### 3.13.1 Lubricating System

Prepare the engine lubricating system for storage as follows:

1. Run the generator set for a minimum of 30 minutes to bring it to normal operating temperature.
2. Stop the generator set.
3. With the engine still warm, drain the oil from the crankcase.
4. Remove and replace the oil filter.
5. Refill the crankcase with oil suited to the climate.
6. Run the generator set for two minutes to distribute the clean oil.
7. Stop the generator set.
8. Check the oil level and adjust, if needed.

### 3.13.2 Cooling System

Prepare the cooling system for storage as follows:

1. Check the coolant freeze protection using a coolant tester.

2. Add or replace coolant as necessary to ensure adequate freezing protection. Use the guidelines included in the engine operation manual.
3. Run the generator set for 30 minutes to redistribute added coolant.

### 3.13.3 Fuel System

Prepare the fuel system for storage as follows:

#### Diesel-Fueled Engines

1. Fill the fuel tank with #2 diesel fuel.
2. Condition the fuel system with compatible additives to control microbial growth.
3. Change the fuel filter/separator and bleed the fuel system. See the engine owner's manual.

#### Gasoline-Fueled Engines

1. Add stabilizer to the fuel system. Follow the manufacturer's recommended procedure.
2. Run the generator set for 15 minutes to ensure that the stabilized fuel reaches the carburetor.
3. Place the generator set master switch in the OFF/RESET position.
4. Close the fuel valve.

#### Gas-Fueled Engines

1. Start the generator set.
2. With the generator set running, shut off the gas supply.
3. Run the generator set until the engine stops.
4. Place the generator set master switch in the OFF/RESET position.

### 3.13.4 Internal Engine Components (Gas/Gasoline-Fueled Engines)

If you have access to a fogging agent or SAE 10 oil prepare the pistons and cylinders for storage as follows:

1. While the engine is running, spray a fogging agent or SAE 10 engine oil into the air intake for about two minutes until the engine stops.
2. Place the generator set master switch in the OFF/RESET position.

If a fogging agent is not available perform the following:

1. Remove the spark plugs.
2. Pour 15 cc (0.5 oz.) of engine oil into each spark plug hole.

**Ignition System Damage.** Refer to the engine operation manual for ignition system precautions before cranking the engine while the spark plug wires are disconnected.

3. Toggle the generator set master switch to crank the engine two or three revolutions to lubricate the cylinders.
4. Reinstall the spark plugs and torque them to specifications.

### 3.13.5 Exterior

1. Clean the exterior surface of the generator set.
2. Seal all engine openings except for the air intake with nonabsorbent adhesive tape.
3. To prevent impurities from entering the air intake and to allow moisture to escape from the engine, secure a cloth over the air intake.
4. Mask electrical connections.
5. Spread a light film of oil over unpainted metallic surfaces to inhibit rust and corrosion.

### 3.13.6 Battery

Perform battery storage after all other storage procedures.

1. Place the generator set master switch in the OFF/RESET position.
2. Disconnect the battery(ies), negative (-) lead first.
3. Clean the battery. Refer to Section 3.10.1 for the battery cleaning procedure.
4. Place the battery in a cool, dry location.
5. Connect the battery to a float/equalize battery charger or charge it monthly with a trickle battery charger. Refer to the battery charger manufacturer's recommendations.

Maintain a full charge to extend battery life.

## Section 4 Troubleshooting

---

This section contains generator set troubleshooting, diagnostic, and repair information.

Use the chart on the following page to diagnose and correct common problems. First check for simple causes such as a dead engine starting battery or an open circuit breaker. The chart includes a list of common problems, possible causes of the problem, recommended corrective actions, and references to detailed information or repair procedures.

Maintain a record of repairs and adjustments performed on the equipment. If the procedures in this manual do not explain how to correct the problem, contact an authorized distributor/dealer. Use the record to help describe the problem and repairs or adjustments made to the equipment.

Trouble Symptoms										Probable Causes	Recommended Actions	Section or Publication Reference*
Does not crank	Cranks but does not start	Starts hard	No or low output voltage	Stops suddenly	Lacks power	Overheats	Low oil pressure	High fuel consumption	Excessive or abnormal noise			
<b>Controller</b>										Controller circuit board(s) inoperative	Replace the controller circuit board.	Gen. S/M
x	x									Controller fault	Troubleshoot the controller. †	Gen. S/M
x	x			x						Controller fuse blown	Replace the blown controller fuse. If the fuse blows again, troubleshoot the controller. †	Section 2, W/D
x										Controller master switch inoperative	Replace the controller master switch.	—
x										Controller master switch in the OFF/RESET position	Move the controller master switch to the RUN or AUTO position.	Section 2
x										Engine start circuit open	Move the controller master switch to the RUN position to test the generator set. Troubleshoot the auto start circuit and time delays.	Section 2, W/D, Gen. I/M, S/M, ATS O/M, S/M
x										Controller interface to engine ECM	Check engine ECM and electrical wiring.	Eng. S/M, W/D
<b>Cooling System</b>												
						x		x		Air openings clogged	Clean the air openings.	—
						x				Coolant level low	Restore the coolant to normal operating level.	Section 3
						x				Cooling water pump inoperative	Tighten or replace the belt. Replace the water pump.	Eng. O/M or S/M
				x						High temperature shutdown	Allow the engine to cool down. Then troubleshoot the cooling system.	Sec. 3, Eng. O/M
				x						Low coolant level shutdown, if equipped	Restore the coolant to normal operating level.	Section 3
						x				Thermostat inoperative	Replace the thermostat.	Eng. S/M
<b>Electrical System (DC circuits)</b>												
x	x									Battery connections loose, corroded, or incorrect	Verify that the battery connections are correct, clean, and tight.	Section 3
x	x									Battery weak or dead	Recharge or replace the battery. The spec sheet provides recommended battery CCA rating.	Section 3, S/S
x	x									Starter/starter solenoid inoperative	Replace the starter or starter solenoid.	Eng. S/M
x				x						Engine harness connector(s) not locked tight	Disconnect the engine harness connector(s) then reconnect it to the controller.	W/D
				x						High water temperature switch inoperative	Replace the inoperative switch.	Gen. S/M or W/D
				x						Fault shutdown	Reset the fault switches and troubleshoot the controller.	Section 2
				x						High exhaust temperature switch inoperative	Replace the inoperative switch.	Gen. S/M or W/D

\* Sec./Section—numbered section of this manual; ATS—Automatic Transfer Switch; Eng.—Engine; Gen.—Generator Set; I/M—Installation Manual; O/M—Operation Manual; S/M—Service Manual; S/S—Spec Sheet; W/D—Wiring Diagram Manual

† Have an authorized service distributor/dealer perform this service.

Trouble Symptoms										Probable Causes	Recommended Actions	Section or Publication Reference*
Does not crank	Crank but does not start	Starts hard	No or low output voltage	Stops suddenly	Lacks power	Overheats	Low oil pressure	High fuel consumption	Excessive or abnormal noise			
<b>Engine</b>												
x										Engine ECM	Troubleshoot engine ECM and electrical.	Eng. S/M, W/D
x	x				x			x		Air cleaner clogged	Clean or replace the filter element.	Eng. O/M
x	x					x		x		Compression weak	Check the compression. †	Eng. S/M
			x		x	x		x		Engine overload	Reduce the electrical load. See the generator set spec sheet for wattage specifications.	S/S
									x	Exhaust system leak	Inspect the exhaust system. Replace the inoperative exhaust system components. †	I/M
									x	Exhaust system not securely installed	Inspect the exhaust system. Tighten the loose exhaust system components. †	I/M
		x			x			x		Governor inoperative	Adjust the governor. †	Gen. S/M
					x					Valve clearance incorrect	Adjust the valves. †	Eng. S/M
									x	Vibration excessive	Tighten all loose hardware.	—
	x	x			x					Ignition system inoperative (gas/gasoline only)	Check the ignition system (spark plugs, spark plug wires, etc.).	Eng. O/M
<b>Fuel System</b>												
x	x				x					Air in fuel system (diesel only)	Bleed the diesel fuel system.	Eng. O/M
x	x									Ether canister empty or system inoperative, if equipped (diesel only)	Replace or repair the ether starting system.	Eng. O/M
x				x						Fuel tank empty or fuel valve shut off	Add fuel and move the fuel valve to the ON position.	—
x					x			x		Fuel feed or injection pump inoperative (diesel only)	Rebuild or replace the injection pump. †	Eng. S/M
x					x					Fuel or fuel injectors dirty or faulty (diesel only)	Clean, test, and/or replace the inoperative fuel injector. †	Eng. S/M
x	x				x					Fuel filter restriction	Clean or replace the fuel filter.	Eng. O/M
x										Fuel solenoid inoperative	Troubleshoot the fuel solenoid. †	Eng. S/M
x					x					Fuel pressure insufficient (gas only)	Check the fuel supply and valves. †	S/S, Gen. O/M
x					x			x		Fuel injection timing out of adjustment (diesel only)	Adjust the fuel injection timing. †	Eng. S/M

\* Sec./Section—numbered section of this manual; ATS—Automatic Transfer Switch; Eng.—Engine; Gen.—Generator Set; I/M—Installation Manual; O/M—Operation Manual; S/M—Service Manual; S/S—Spec Sheet; W/D—Wiring Diagram Manual

† Have an authorized service distributor/dealer perform this service.

Trouble Symptoms										Probable Causes	Recommended Actions	Section or Publication Reference*
Does not crank	Cranks but does not start	Starts hard	No or low output voltage	Stops suddenly	Lacks power	Overheats	Low oil pressure	High fuel consumption	Excessive or abnormal noise			
<b>Alternator</b>												
			x							AC output circuit breaker open	Reset the breaker and check for AC voltage at the generator side of the circuit breaker.	—
x										Transfer switch test switch in the OFF position	Move the transfer switch test switch to the AUTO position.	ATS O/M
			x							Transfer switch fails to transfer load	Move the ATS test switch to the AUTO position. Troubleshoot the transfer circuit and time delays.	ATS O/M, S/M
			x							Wiring, terminals, or pin in the exciter field open	Check for continuity.	Gen. S/M, W/D
			x							Main field (rotor) inoperative (open or grounded)	Test and/or replace the rotor.†	Gen. S/M
			x							Stator inoperative (open or grounded)	Test and/or replace the stator.†	Gen. S/M
									x	Vibration excessive	Tighten loose components.†	—
			x	x						Voltage regulator digital settings incorrect (digital controller only)	Adjust the voltage regulator.	Sec. 2, Menu 11
			x	x						Voltage regulator inoperative	Replace the voltage regulator fuse, if the fuse blows again, troubleshoot the voltage regulator.	Gen. S/M
			x	x						Voltage regulator out of adjustment	Adjust the voltage regulator.	Gen. S/M
<b>Lube System</b>												
	x	x					x		x	Crankcase oil type incorrect for ambient temperature	Change the oil. Use oil with a viscosity suitable for the operating climate.	Eng. O/M
							x		x	Oil level low	Restore the oil level. Inspect the generator set for oil leaks.	Eng. O/M
										Low oil pressure shutdown	Check the oil level.	Eng. O/M

\* Sec./Section—numbered section of this manual; ATS—Automatic Transfer Switch; Eng.—Engine; Gen.—Generator Set; I/M—Installation Manual; O/M—Operation Manual; S/M—Service Manual; S/S—Spec Sheet; W/D—Wiring Diagram Manual

† Have an authorized service distributor/dealer perform this service.



## Section 5 Generator Set Reconnection

To change the voltage of 10- or 12-lead generator sets, use the following voltage reconnection procedure. Adjust the governor and voltage regulator for frequency changes. Consult the generator set service manual for frequency adjustment information.

**Voltage reconnection.** Affix a notice to the generator set after reconnecting the set to a voltage different from the voltage on the nameplate. Order voltage reconnection decal 246242 from an authorized service distributor/dealer.

**Equipment damage.** Verify that the voltage ratings of the transfer switch, line circuit breakers, and other accessories match the selected line voltage.

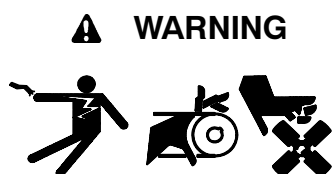

**Accidental starting.**  
**Can cause severe injury or death.**

Disconnect the battery cables before working on the generator set. Remove the negative (-) lead first when disconnecting the battery. Reconnect the negative (-) lead last when reconnecting the battery.

**Disabling the generator set. Accidental starting can cause severe injury or death.** Before working on the generator set or equipment connected to the set, disable the generator set as follows: (1) Turn the generator set master switch and switchgear engine control switch to the OFF position. (2) Disconnect the power to the battery charger. (3) Remove the battery cables, negative (-) lead first. Reconnect the negative (-) lead last when reconnecting the battery. Follow these precautions to prevent the starting of the generator set by an automatic transfer switch or a remote start/stop switch.

**Disabling the generator set. Accidental starting can cause severe injury or death.** Before working on the generator set or connected equipment, disable the generator set as follows: (1) Move the generator set master switch to the OFF position. (2) Disconnect the power to the battery charger. (3) Remove the battery cables, negative (-) lead first. Reconnect the negative (-) lead last when reconnecting the battery. Follow these precautions to prevent starting of the generator set by an automatic transfer switch, remote start/stop switch, or engine start command from a remote computer.

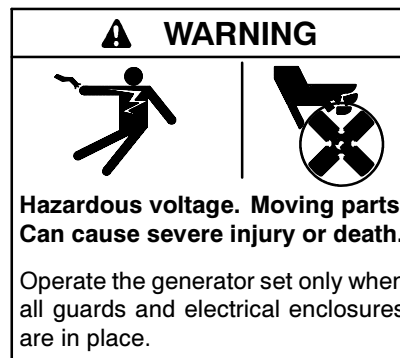

**Short circuits. Hazardous voltage/current can cause severe injury or death.** Short circuits can cause bodily injury and/or equipment damage. Do not contact electrical connections with tools or jewelry while making adjustments or repairs. Remove all jewelry before servicing the equipment.

Reconnect the generator set stator leads to change the output phase or voltage. Refer to the following procedure and the connection schematics shown in Figure 5-1, Figure 5-2, Figure 5-3, and Figure 5-4. Follow the safety precautions at the front of this manual and in the text and observe National Electrical Code (NEC) guidelines.

### Voltage Reconnection Procedure

1. Place the generator set master switch in the OFF/RESET position.
2. Disconnect the generator set engine starting battery, negative (-) lead first. Disconnect power to the battery charger (if equipped).
3. Use Figure 5-1, Figure 5-2, Figure 5-3, and Figure 5-4 to determine the generator set voltage configuration. Note the original voltage and reconnect as needed. Route leads through current transformers (CTs) and connect them according to the diagram for desired phase and voltage.

**Note:** Position current transformers CT1, CT2, and CT3 with the dot or HI side toward the generator set.

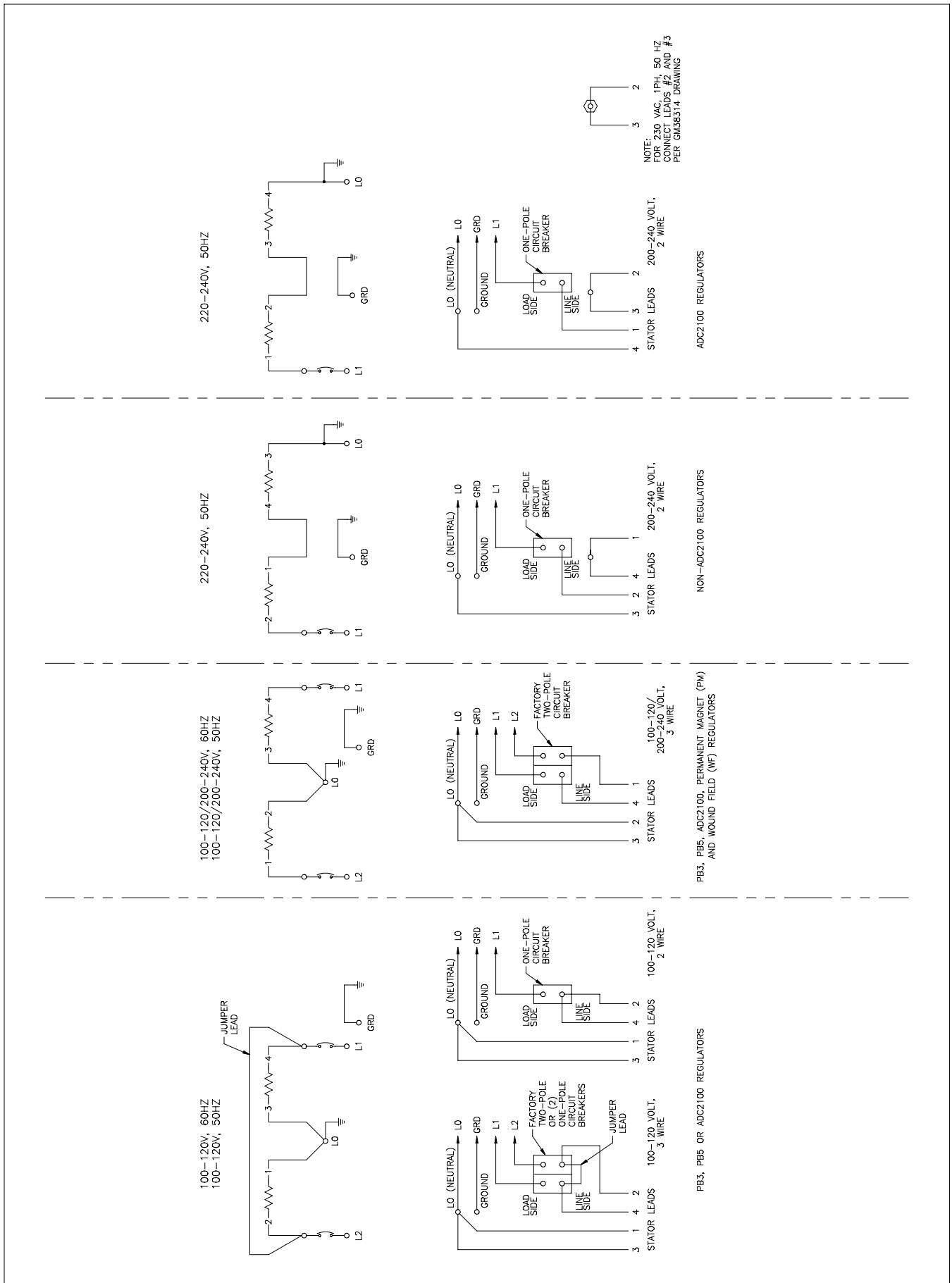

Figure 5-1 20-150 kW Permanent Magnet and Wound Field Single-Phase Alternators, ADV-5875A-H

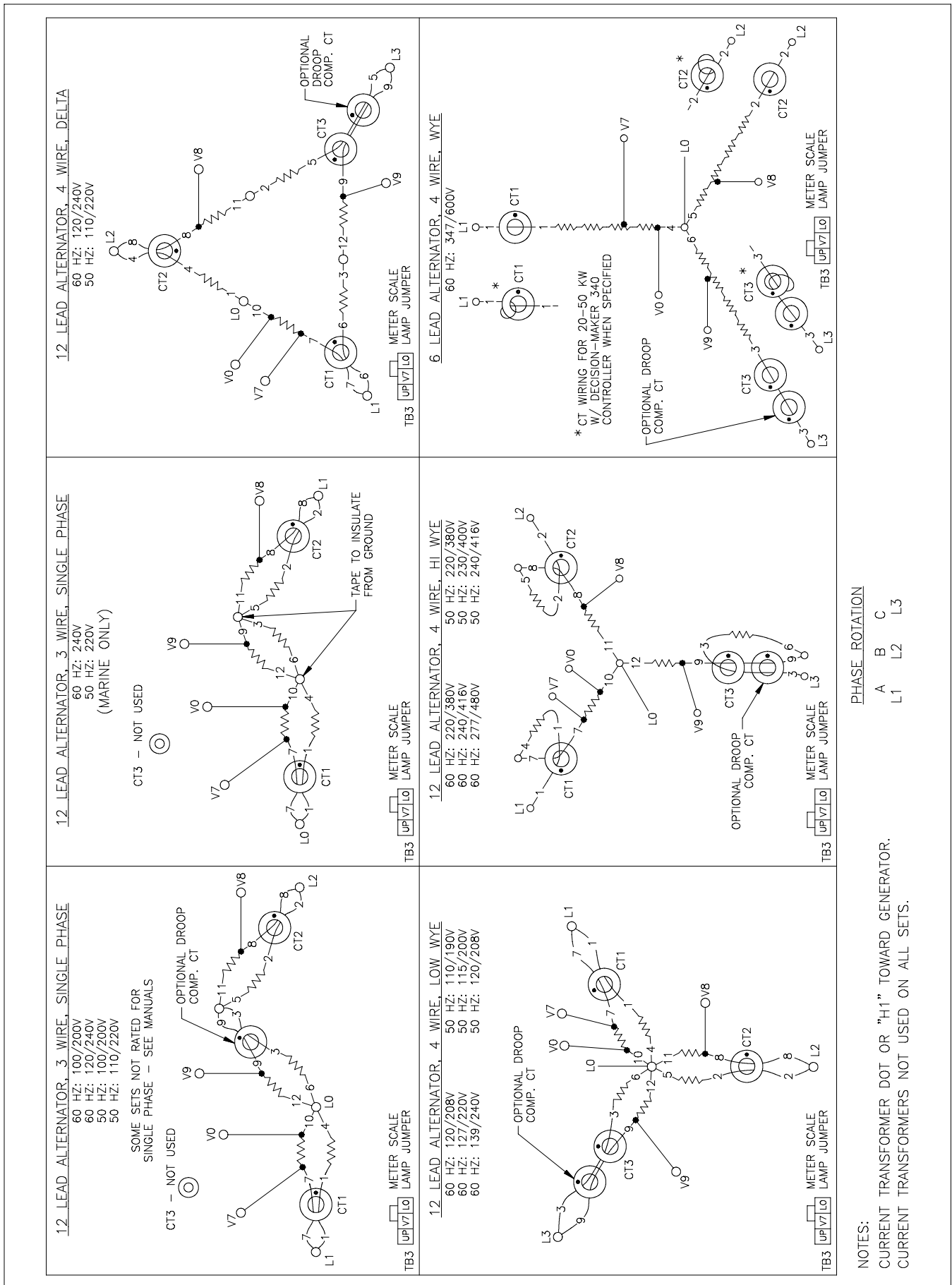

Figure 5-2 20-300 kW Permanent Magnet and 20-60 kW Wound Field Alternators, ADV-5875B-H

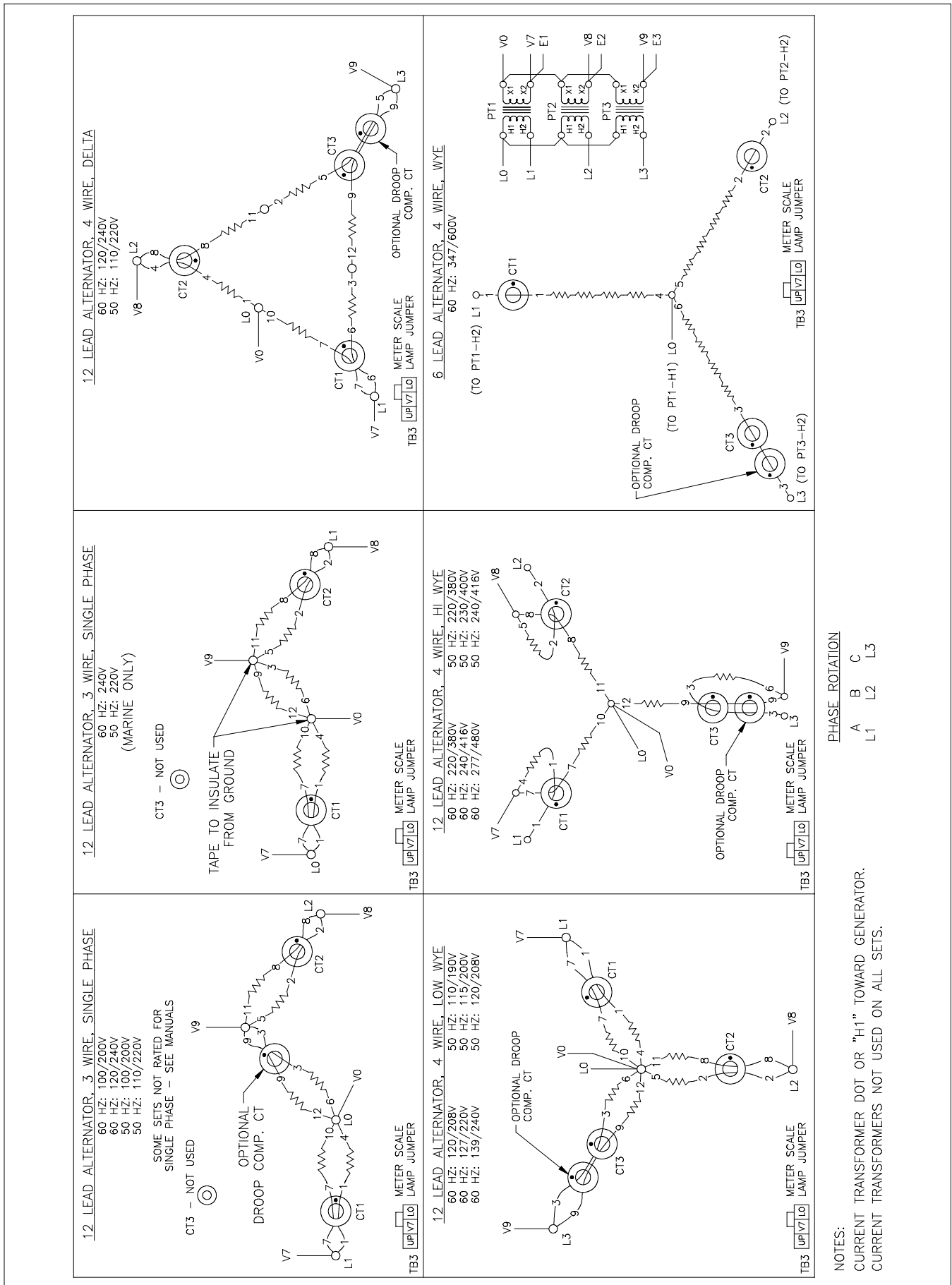

Figure 5-3 60 (with Oversize Alternator)-300 kW Wound Field Alternators, ADV-5875C-H

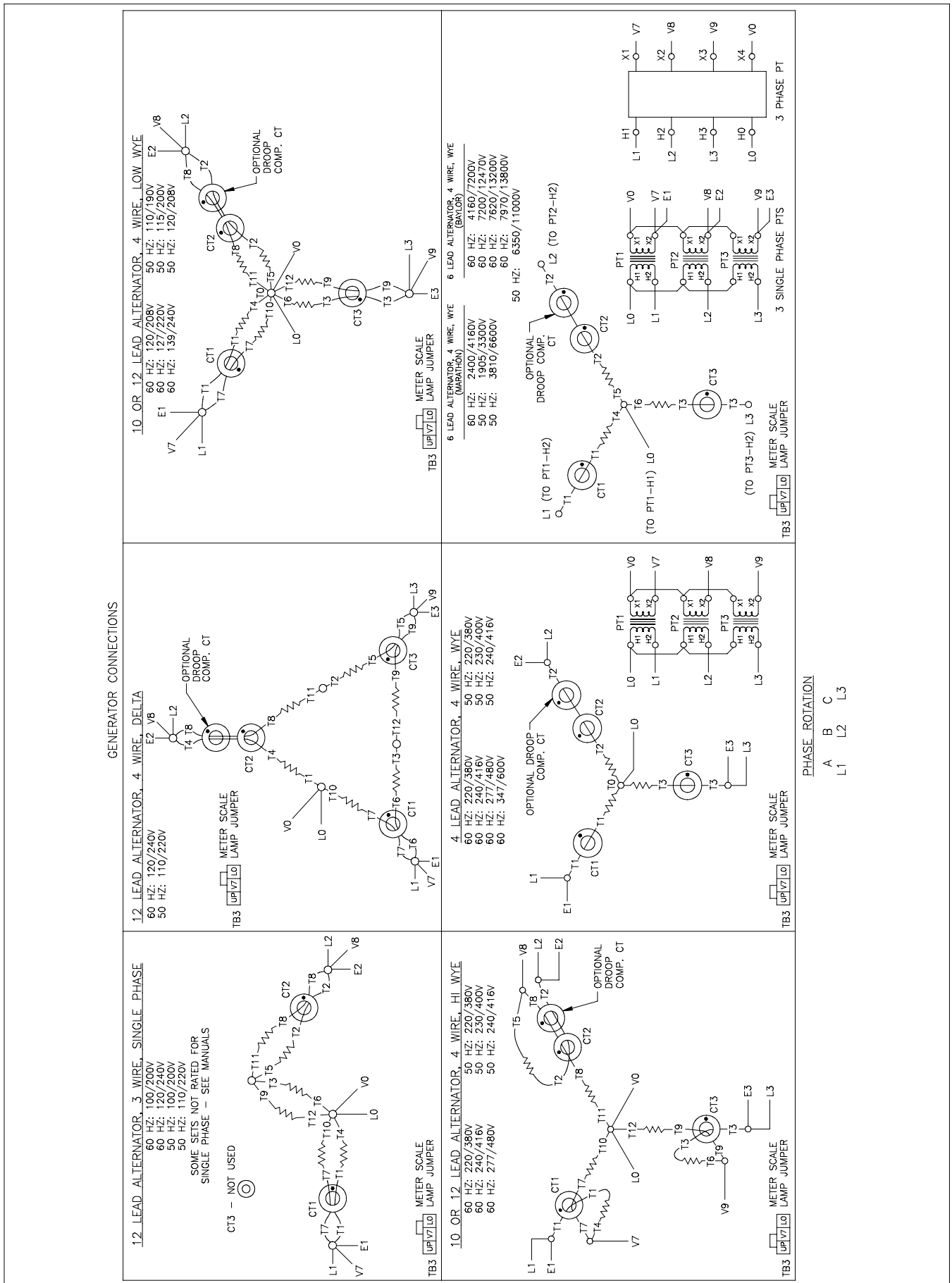
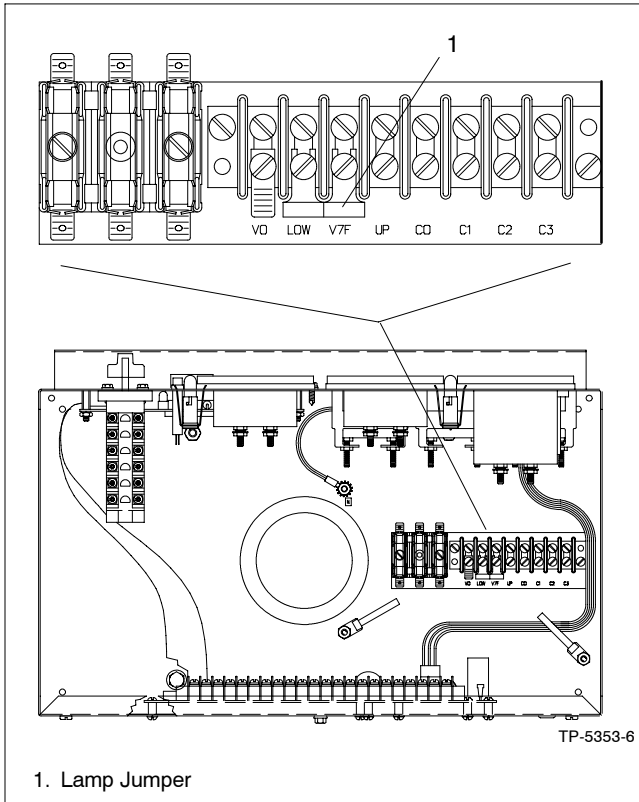

Figure 5-4 350-2000 kW Pilot-Excited, Permanent Magnet Alternator, ADV-5875D-H

- Remove the controller cover and reposition the meter scale lamp jumper (see Figure 5-5) to match the position for desired voltage (shown in Figure 5-1, Figure 5-2, Figure 5-3, and Figure 5-4). Replace the controller cover.



**Figure 5-5** Meter Scale Lamp Jumper

- Set the phase selector switch to the L1-L2 position (1-phase or 3-phase depending on generator set connection). Connect a voltmeter across leads L1 and L2 if the controller has no meters.

- Reconnect the starting battery, negative (-) lead last. Place the generator set master switch in the RUN position to start the generator set. Check the voltmeter to verify that the voltage changed to the desired value.
  - 20–300 kW Models: Adjust the voltage with the voltage adjustment control on the generator set controller front panel (or switchgear). See Figure 5-6.

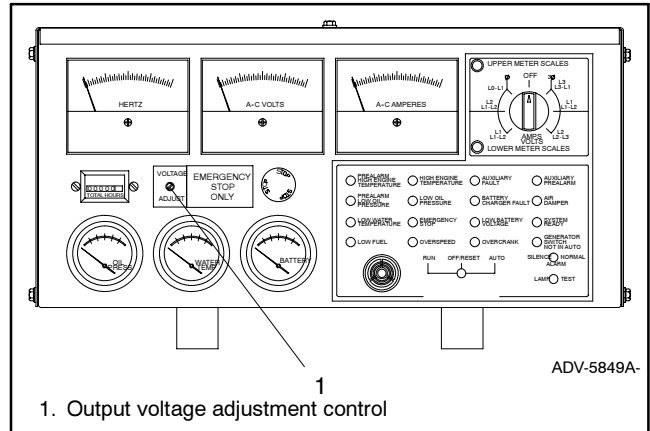

**Figure 5-6** Voltage Adjustment

- 350–2000 kW Models: Adjust the voltage with the voltage adjustment control on the voltage regulator (or switchgear). Use the applicable technical manual for voltage regulator adjustment.
- Stop the generator set after completing the voltage adjustment. Replace the controller cover.

6.1 Accessories

Several electrical accessories and controls help finalize installation, add convenience to operation and service, and establish state and local code compliance.

Accessories vary with each generator set model and controller. Select factory-installed and/or shipped-loose accessories. Kit and installation instruction part numbers change. Obtain the most current accessory information from your local authorized service distributor/dealer.

This section illustrates several accessories available at the time of print of this publication. Accessory kits generally include installation instructions. See the wiring diagrams manual for electrical connections not shown in this section. See the installation instructions and drawings supplied with the kit for information on the kit mounting location.

The instructions provided with the accessory kit supersede these instructions where there are differences. In general, run AC and DC wiring in separate conduit. Use shielded cable for all analog inputs. Observe all applicable national, state, and local electrical codes during accessory installation.

**Note:** The accessories with the (M) notation are available only on models with 16-light microprocessor controllers.

6.1.1 Audiovisual Alarm (M)

An audiovisual alarm warns the operator of fault shutdowns and prealarm conditions (except battery charger fault and low battery voltage) from a remote location. Audiovisual alarms include an alarm horn, an alarm silence switch, and a common fault lamp. See Figure 6-1.

**Note:** Use the audiovisual alarm with a dry contact kit.

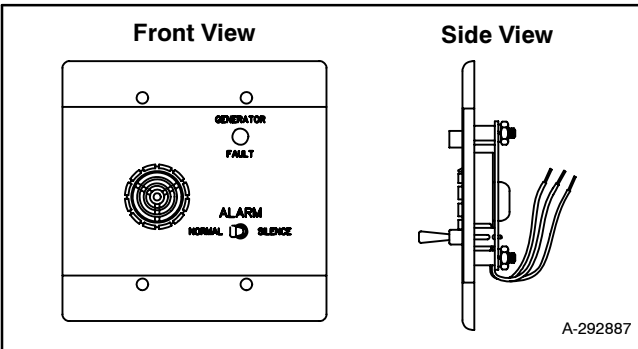

Figure 6-1 Audiovisual Alarm

6.1.2 Common Failure Relay Kit (M)

The common failure relay kit provides one set of contacts to trigger user-provided warning devices if a fault occurs. The common failure relay faults are user-defined.

Connect up to three common failure relay kits to the controller output. See Figure 6-2. See Section 6.2, Accessory and Prime Power Terminal Strip Connections, for terminal identification.

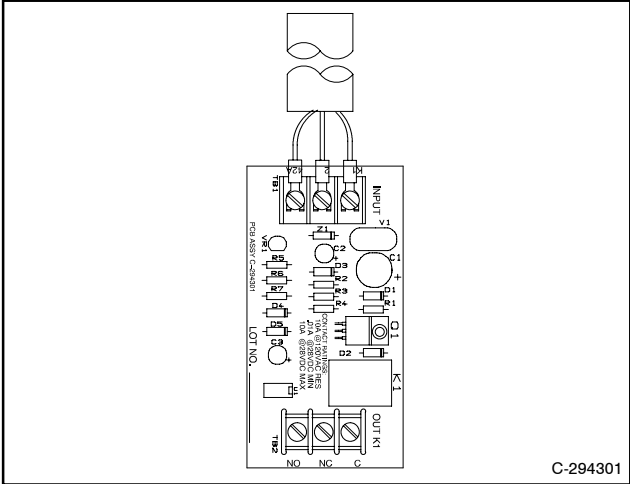

Figure 6-2 Common Failure Relay Kit

6.1.3 Controller Connection Kit (M)

The controller connection kit allows easy connection of controller accessories without accessing the controller terminal strip. The kit uses a 165-cm (65-in.) wiring harness to link the controller terminal strip(s) with a remote terminal strip located in the generator set junction box. With the exception of a few terminals the remote terminal strip is identical to that of the controller. Connect all accessories except the emergency stop kit to the connection kit terminal strip.

### 6.1.4 Dry Contact Kit (Single-Relay) (M)

The single-relay dry contact kit uses one set of contacts to trigger customer-provided warning devices if a fault condition occurs. Connect any controller fault output connection from the TB1 terminal strip to the single-relay kit. Use the single-relay dry contact kit as a common fault relay for signaling any of the following common fault conditions:

- Emergency Stop
- Auxiliary
- Overspeed
- Low Oil Pressure
- High Engine Temperature

Connect a maximum of three dry contact kits to a single controller output. See Figure 6-3.

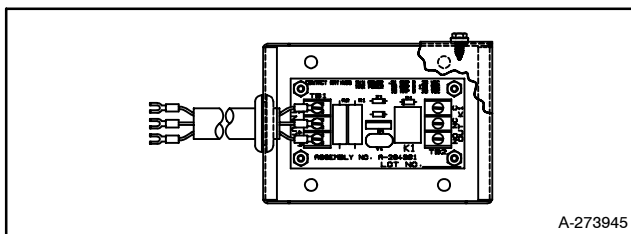

Figure 6-3 Single-Relay Dry Contact Kit, Typical

### 6.1.5 Dry Contact Kits (10-, 14-, and 20-Relay) (M)

Dry contact kits allow monitoring of the generator set system and provide the ability to activate warning devices and other customer-provided accessories. Available kits include 10, 14, or 20 sets of relay contacts for connecting customer-provided devices to desired generator set functions. The 20-relay kits can be used on 450 kW and larger generator sets. The 10-relay and 20-relay kits provide normally open and normally closed contacts. The 14-relay kit provides normally open contacts only.

Warning devices (lamp and/or audible alarms) and other accessories typically connect to the controller output connections listed below. A total of three dry contact kits may connect to a specific output connection on the controller. Figure 6-4 shows some typical dry contact kits mounted on an assembly panel for 450 kW and larger generator sets.

Typical 10- and 14-relay contact kit output connections include:

- Overspeed
- Overcrank
- High engine temperature
- Low oil pressure

- Low water temperature
- Auxiliary fault
- Anticipatory high engine temperature
- Anticipatory low oil pressure
- Emergency stop

Additional connections available with the 20-relay kits include:

- Battery charger fault
- Low battery voltage
- Low fuel level
- Engine trouble
- Not in AUTO
- System ready
- Common fault
- Overcrank
- Crank terminate
- Cooldown

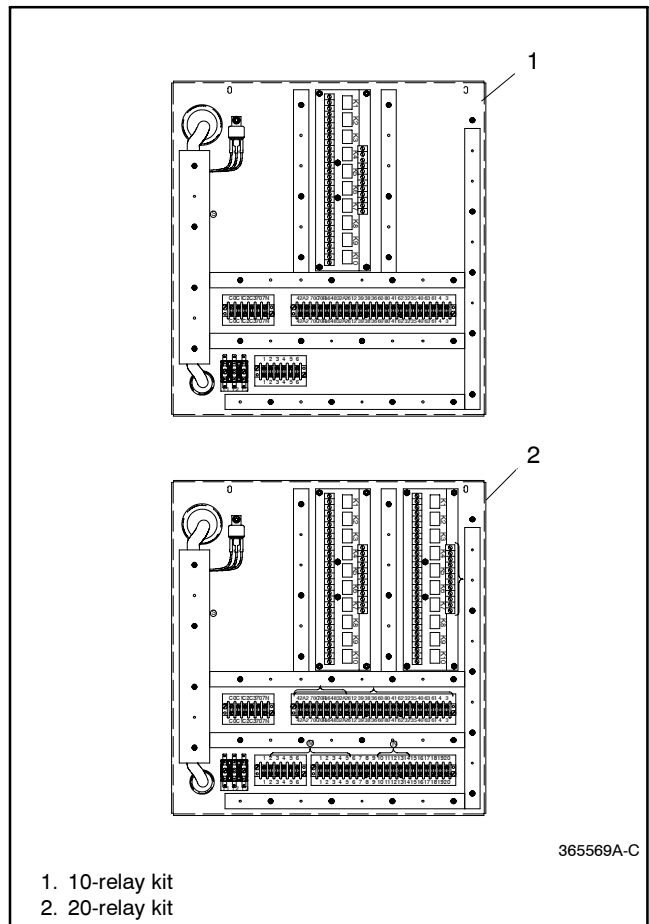

Figure 6-4 Dry Contact Kits (shown mounted on assembly panel for 450 kW and larger generator sets)



### 6.1.6 Engine Prealarm Senders (M)

Alert the user of low water temperature, approaching low oil pressure, and approaching high engine temperature. Kits for gas-fueled models include a low fuel pressure switch.

### 6.1.7 FASTCHECK Diagnostic Tester (M)

The FASTCHECK® diagnostic tester simulates engine operation to identify faults in the controller and engine circuitry. Use the FASTCHECK® when troubleshooting startup problems or to test and troubleshoot the controller when it is removed from the generator set. Perform tests without starting the generator set. FASTCHECK® functions are listed below; refer to Figure 6-5 to identify LEDs and switches.

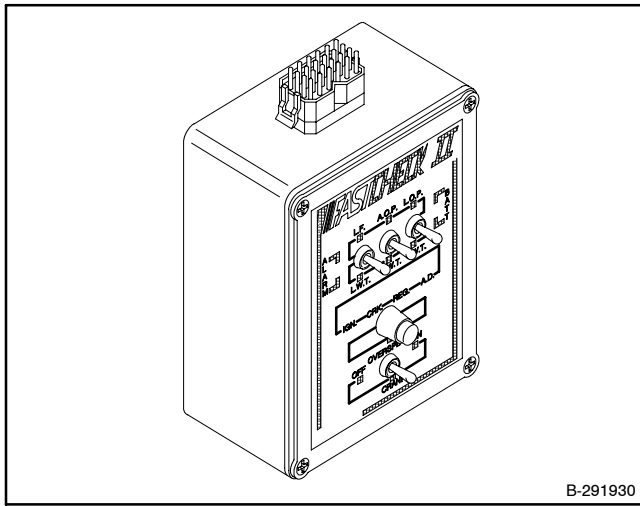

**Figure 6-5** FASTCHECK® Diagnostic Tester

LEDs on the FASTCHECK® illuminate to indicate the energizing of the following circuits:

- AC Voltage Regulator
- Battery Connection (correct polarity)
- Engine Ignition (gas/gasoline)
- Engine Crank
- Engine Antidieseling
- Engine Malfunction Alarm and/or Alarm Shutdown
- Fuel Solenoid (diesel)

Switches on the FASTCHECK® simulate the following:

- Anticipatory High Engine Coolant Temperature
- Anticipatory Low Engine Oil Pressure
- Engine Crank
- Engine Overspeed
- Engine Running
- High Engine Coolant Temperature
- Low Engine Coolant Temperature
- Low Engine Oil Pressure
- Low Fuel

### 6.1.8 Float/Equalize Battery Charger Kit with Alarm Option (M)

The float/equalize battery charger with alarm option provides battery charging to the engine starting battery(ies) and connects to the controller for fault detection. Battery chargers for 12- or 24-volt models are available as a generator set accessory.

See Figure 6-6. See Section 6.2, Accessory and Prime Power Terminal Strip Connections, for terminal identification.

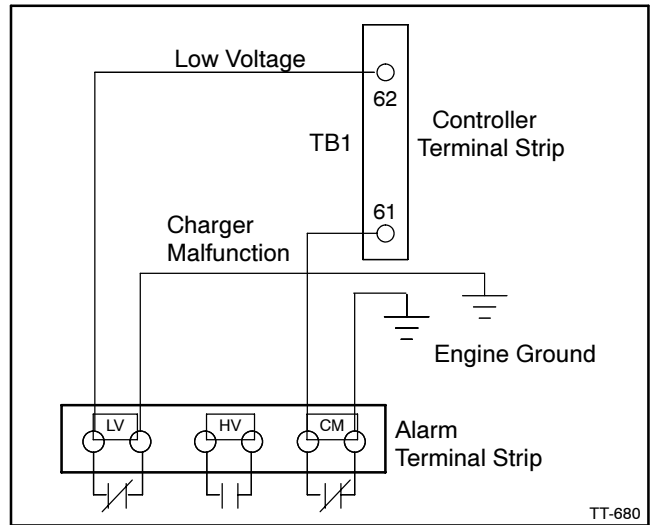

**Figure 6-6** Float/Equalize Battery Charger Connections

### 6.1.9 Line Circuit Breaker

The line circuit breaker interrupts generator output if an overload or short circuit occurs. Use the line circuit breaker to manually disconnect the generator set from the load during generator set service. See Figure 6-7.

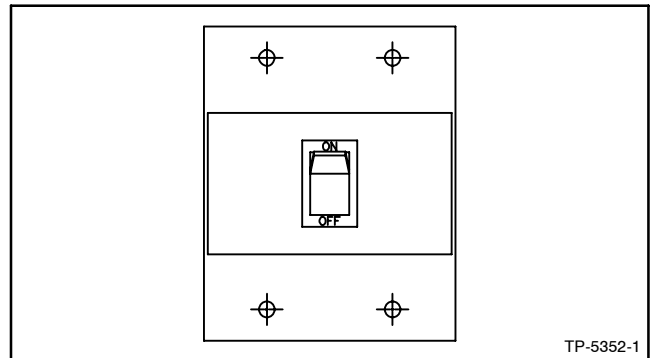
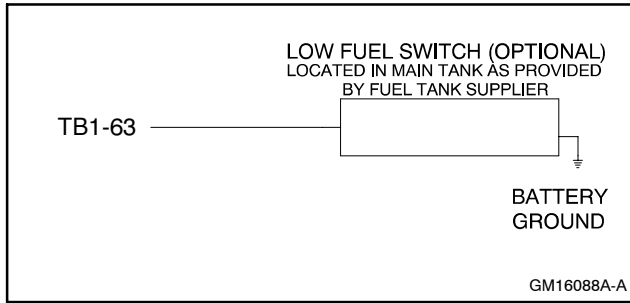

**Figure 6-7** Line Circuit Breaker

### 6.1.10 Low Fuel Switch (M)

Some gaseous-fueled models offer a low fuel pressure switch as part of the Engine Prealarm Senders kit. The low fuel pressure switch connects to the same terminal as the low fuel *level* switch on diesel- or gasoline-fueled models. See Figure 6-8 and Figure 6-9. See Section 6.2, Accessory and Prime Power Terminal Strip Connections, for terminal identification.

**Note:** The subbase fuel tank or main tank may include the low fuel level switch. The fuel tank supplier typically provides the low fuel level switch.



**Figure 6-8** Low Fuel Switch (Level or Pressure)

<b>Switch Rating</b>	12 volts DC minimum, 0.5 amp minimum
<b>Wiring Recommendation</b>	
<b>Gauge</b>	<b>mm (ft.)</b>
18-20	30.5 (100)
14	153 (500)
10	305 (1000)

**Figure 6-9** Switch Rating and Wiring Recommendation

### 6.1.11 Remote Annunciator Kit (M)

A remote annunciator provides convenient monitoring of the generator set's condition from a remote location. See Figure 6-10. The remote annunciator includes an alarm horn, alarm silence switch, lamp test, and the same lamp indicators (except air damper) as the 16-light controller, plus the following lamps:

**Line Power** lamp illuminates to indicate that the commercial utility is the power source.

**Generator Power** lamp illuminates to indicate that the generator set is the power source.

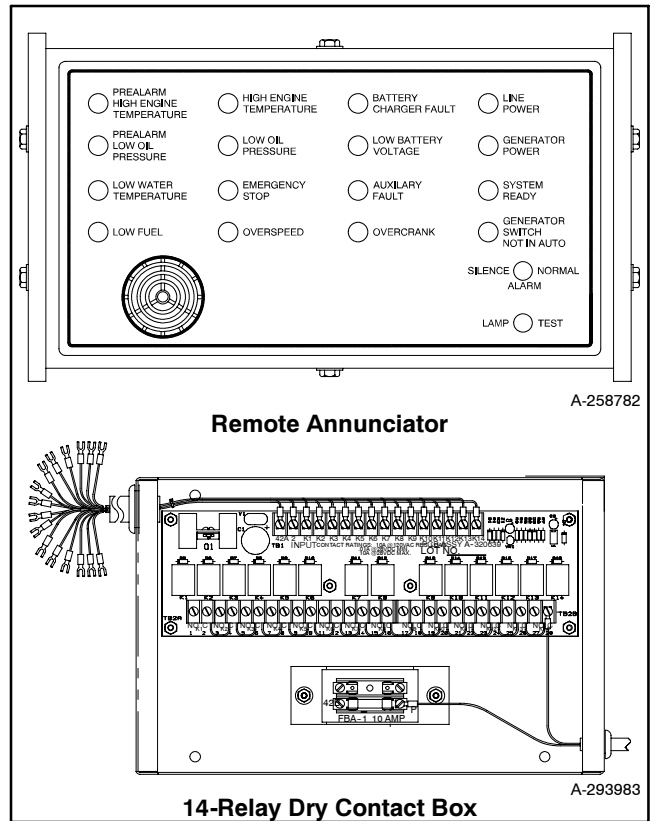

**Figure 6-10** Remote Annunciator with 14-Relay Dry Contact Box

### 6.1.12 Remote Emergency Stop Kit (M)

The emergency stop kit shuts down the generator set from a remote location in an emergency. See Figure 6-11. Activating the emergency stop switch lights the EMERGENCY STOP lamp and shuts down the unit. Before restarting the generator set, reset emergency stop switch by replacing the glass piece and reset the generator set by placing the master switch in the OFF/ RESET position. The switch holds a single replacement glass piece, which is available as a service part.

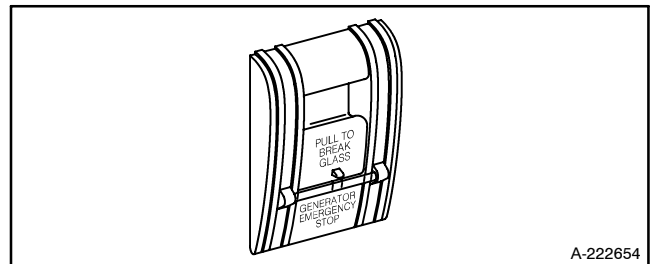

**Figure 6-11** Emergency Stop Kit

### 6.1.13 Remote Serial Annunciator (M)

The remote serial annunciator monitors the condition of the generator set from a location remote from the generator set. If a generator alarm condition occurs, the remote annunciator alerts the operator through visual and audible signals using a RS-485 controller connection. See Figure 6-12. Requires a controller communication module kit installed in the controller. See Figure 6-13.

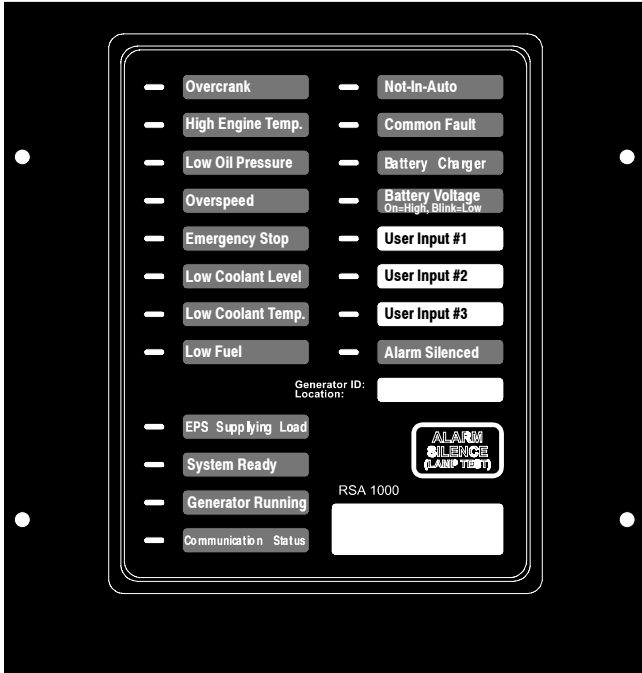

Figure 6-12 Remote Serial Annunciator (RSA)

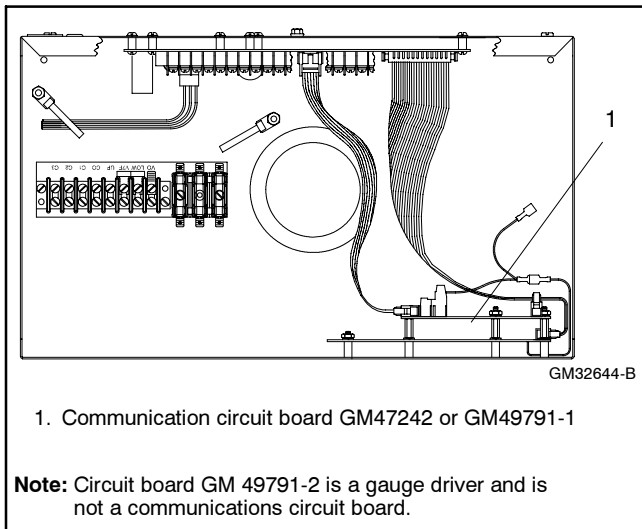

Figure 6-13 16-Light Controller with Installed Comm. Module (controller top view)

### 6.1.14 Run Relay Kit

The run relay kit includes three sets of contacts that energize only during generator set operation. The run relay kit can control air intake louvers, radiator louvers, alarms, and other signaling. See Figure 6-14.

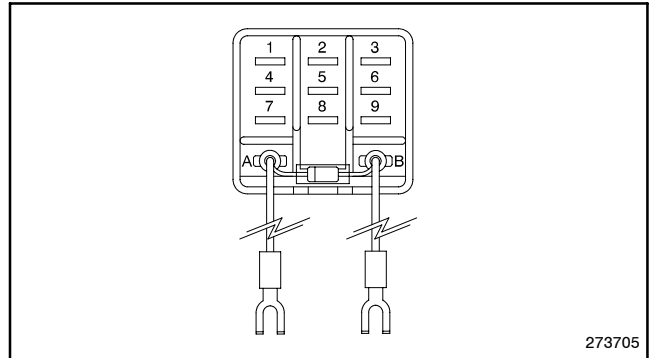

Figure 6-14 Run Relay Kit

### 6.1.15 Safeguard Breaker

The safeguard breaker senses output current on each generator phase and shuts off the AC voltage regulator if a sustained overload or short circuit occurs. It is not a line circuit breaker and does not disconnect the generator set from the load. See Figure 6-15.

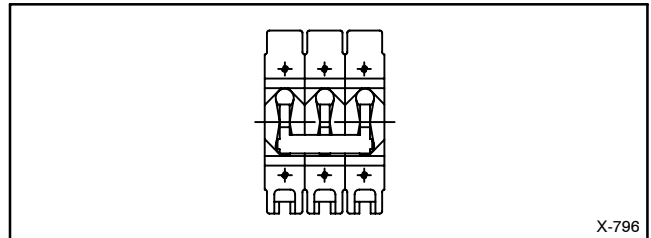

Figure 6-15 Safeguard Breaker

## 6.2 Accessory and Prime Power Terminal Strip Connections (M)

The 16-light controller circuit board has terminal strips for use in connecting a controller connection kit. Do not connect accessories directly to the controller terminal strip(s). Connect accessories to either a controller connection kit or dry contact kit. Connect the dry contact kit(s) to the controller connection kit. Connect alarms, battery chargers, remote switches, and other accessories to the dry contact kit relay(s).

The 16-light controller has two terminal strips, TB1 and TB2, on the controller circuit board, and prime power choices are made on TB2. See Figure 6-16 for controller configurations. See Figure 6-17 and Figure 6-18 for controller terminal strip identification.

Lower the controller circuit board panel until it is lying flat when connecting the dry contact kits to the controller TB1 terminal strip. Route dry contact relay leads through the controller grommet and guide loops to the circuit board terminal strip. Place the controller circuit board panel flat to ensure adequate slack in the dry contact relay leads. For specific information on accessory connections refer to the accessory wiring diagrams in the Wiring Diagram Manual and the instruction sheet accompanying the kit.

**Note:** Not all terminals are used for all generator sets (see appropriate wiring diagrams for specific generator set models).

**Note:** To use the prime power mode, use jumpers to connect TB2-1P to TB2-2P, TB2-3P to TB2-4P, and TB2-3 to TB2-4. To deactivate the prime power mode, remove these jumpers.

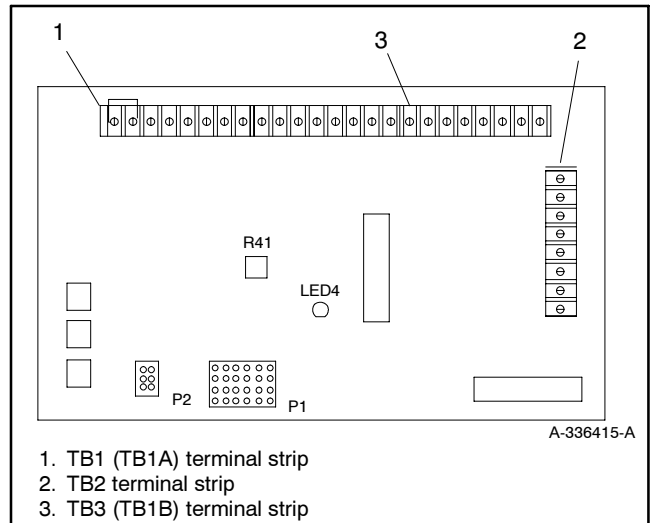

**Figure 6-16** TB1 and TB2 Terminal Strips on the 16-Light Controller

Terminal	Purpose
1P	Prime power operation.
2P	Prime power operation.
3	Remote start ground. Connect transfer switch or remote start switch to TB2-3 and TB2-4.
3P	Prime power operation.
4	Remote start. Connect transfer switch or remote start switch to TB2-3 and TB2-4.
4P	Prime power operation.
9	Crank mode selection (open: cyclic crank, ground: continuous crank). Connect TB2-9 to TB2-9A for continuous cranking; leave TB2-9 open cyclic cranking; see starting instructions in Section 2, Operation.
9A	Crank mode ground.

**Figure 6-17** 16-Light Controller TB2 Terminal Strip

Terminal on TB1 (TB1A) or TB3 (TB1B)	Purpose
1	Ground. Emergency stop relay (K4). Connect emergency stop across terminals TB1-1 and 1A. *
1A	Emergency stop relay (K4) coil; negative side. Connect emergency stop across terminals TB1-1 and 1A. *
2	Ground terminal.
12	Overcrank (OC) signal. †
26	Auxiliary (AUX) signal. †
32	Common fault/prealarm line 1. audiovisual alarm or common fault relay activated by OC, 12; AUX, 26; LWT, 35; HET, 36; LOP, 38; OS, 39; AHET, 40; ALOP, 41; and LF, 63 faults.
32A	Common fault/prealarm line 2. audiovisual alarm or common fault relay activated by AUX, 26; HET, 36; LOP, 38; OS, 39; and ES, 48 faults.
35	Low water temperature (LWT) signal.
36	High engine temperature (HET) signal. †
38	Low oil pressure (LOP) signal. †
39	Overspeed (OS) signal. †
40	Anticipatory high engine temperature (AHET) signal. †
41	Anticipatory low oil pressure (ALOP) signal. †
42A	Battery voltage (fuse #1 protected). Accessory power supply; Customer may also provide separate accessory power source.
48	Emergency stop (ES) signal. †
56	Air damper (AD) switch.
60	System ready signal. †
61	Battery charger fault. Connect battery charger alarm contact to activate fault lamp (active low) (if used).
62	Low battery volts. Connect battery charger alarm contact to activate fault lamp (active low) (if used).
63	Low fuel (LF) fault. Connect fuel level sensor to activate fault lamp (active low) (if used).
70C	Generator in cool down mode signal.
70R	Generator in running mode signal.
80	Not in auto signal. †

\* Connect jumper across terminals 1 and 1A if emergency stop switch is not used.  
† Use a remote annunciator and/or audiovisual alarm kit as an indicator with a dry contact kit connected to controller terminal strip TB1 (TB1A) and TB3 (TB1B).

**Figure 6-18** 16-Light Controller TB1 (TB1A) and TB3 (TB1B) Terminal Strips

## 6.3 Communication Module Kit and Gauge Driver Circuit Board

When a remote serial annunciator (RSA) is connected to a Decision-Maker™ 3+ controller, a communication module circuit board is required. See Figure 6-19 for location and connection.

The communication module circuit board location may also be occupied by an interface circuit board with gauge drivers required for some models\*. Do not confuse the function of these circuit boards.

\* See the Introduction section and refer to Tech Tools, Engine Electronic Module (ECM) for the latest applications.

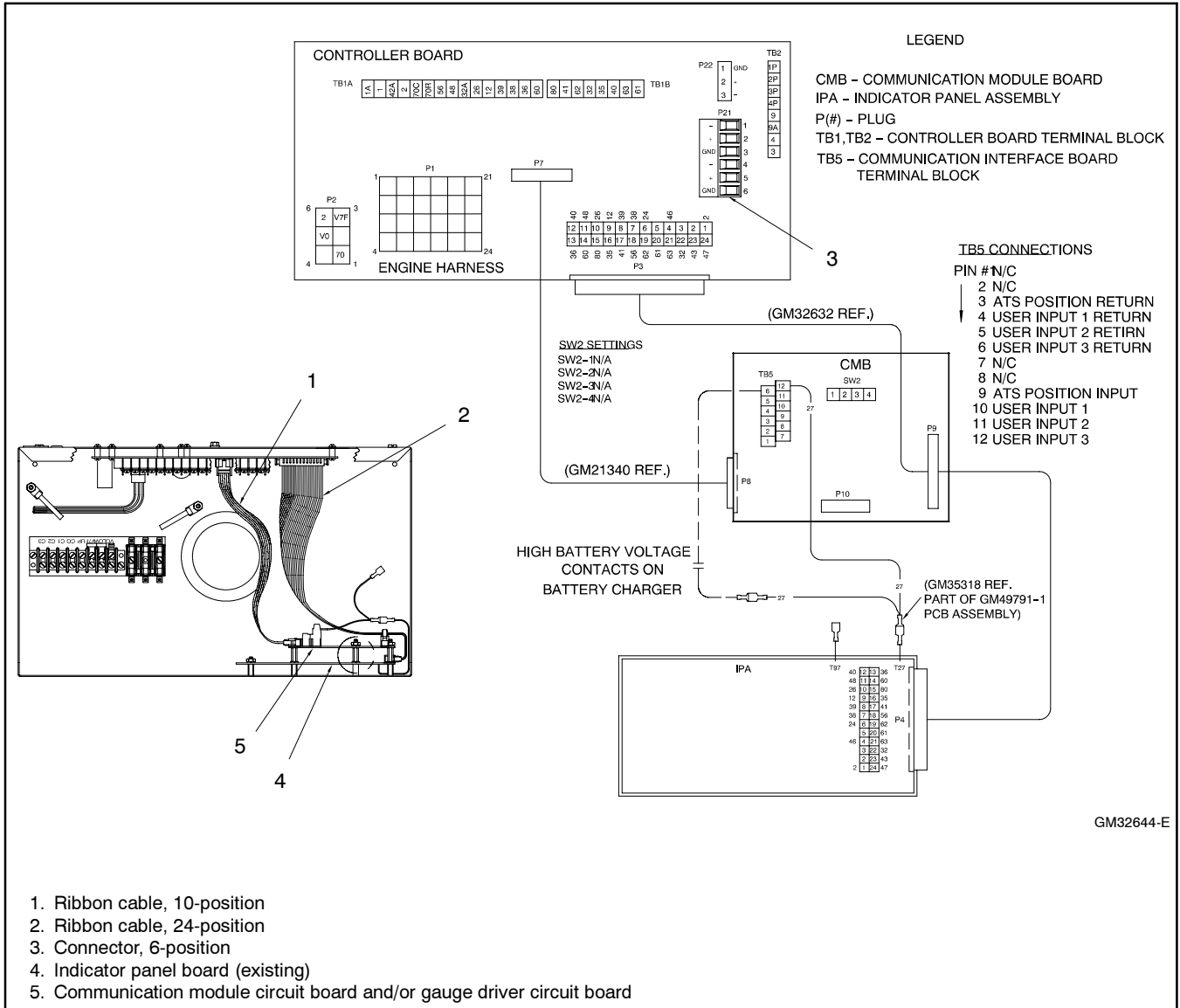
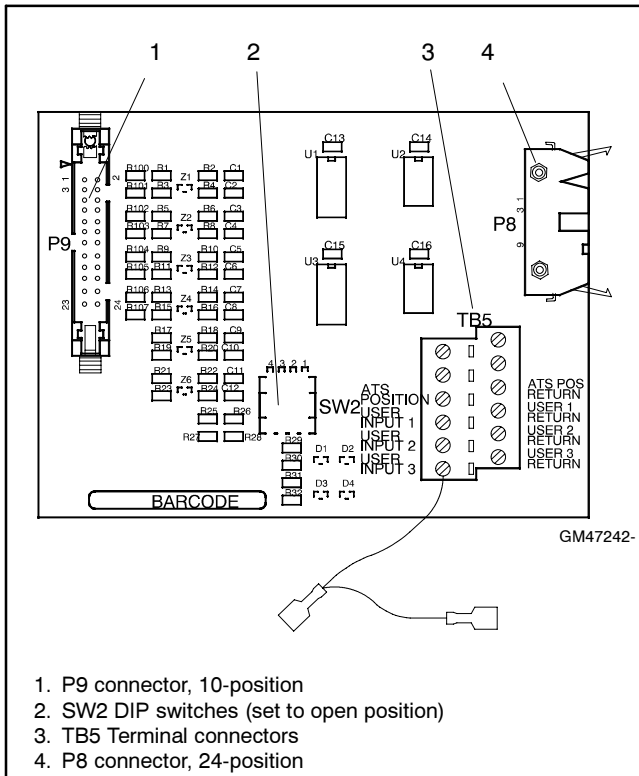

Figure 6-19 Communication Module Circuit Board Location and Connection

### 6.3.1 Communication Modules (Circuit Board) Versions

**GM47242 Circuit Board.** This is the communication module for all models except the 450/500REOZVB models and is superceded by GM49791-1. See Figure 6-20.



**Figure 6-20** Communication Circuit Board GM47242

**GM49791-1 Circuit Board.** This is the communication module for all models and includes the gauge driver provision needed to drive the oil pressure and water temperature gauges for some models (requires application software version 1.23 or later). See Figure 6-21.

**GM49791-2 Circuit Board.** This is the interface circuit board with the gauge drivers required on the 450/500REOZVB models only. For communication purposes replace GM49791-2 with GM49791-1. GM49791-2 is mounted in the communication module location but does not provide the communication function. See Figure 6-22.

### 6.3.2 Circuit Boards Views

Figure 6-20, Figure 6-21, and Figure 6-22 show the differences between the communication circuit boards and the interface circuit board with gauge drivers. The SW2 DIP switches should be set to the open position unless the instructions supplied with the kit indicate another configuration.

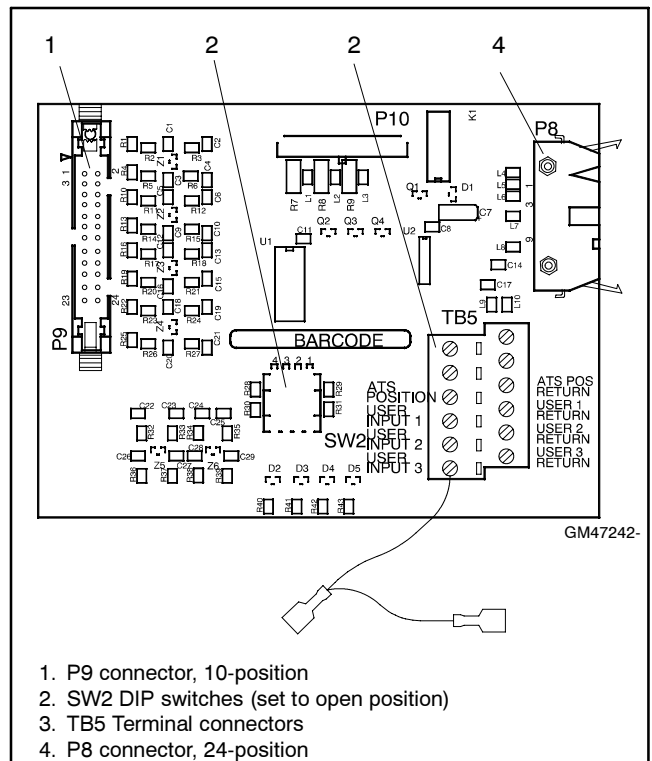

**Figure 6-21** Communication Circuit Board GM49791-1

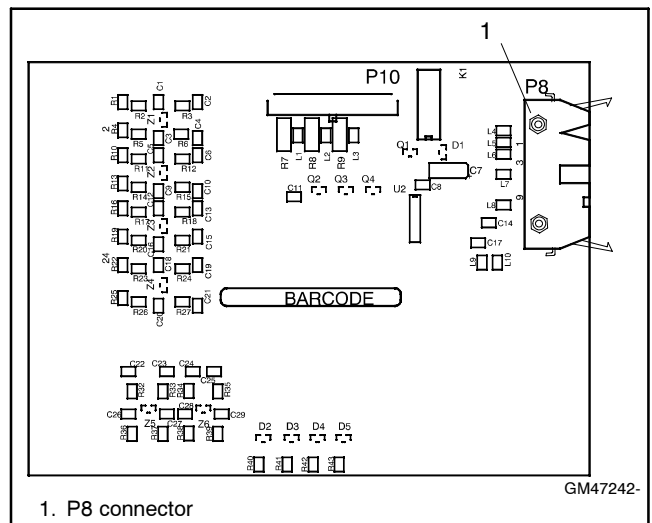

**Figure 6-22** Gauge Driver Circuit Board GM49791-2

# Notes



# Appendix A Abbreviations

The following list contains abbreviations that may appear in this publication.

A, amp	ampere	cfm	cubic feet per minute	est.	estimated
ABDC	after bottom dead center	CG	center of gravity	E-Stop	emergency stop
AC	alternating current	CID	cubic inch displacement	etc.	et cetera (and so forth)
A/D	analog to digital	CL	centerline	exh.	exhaust
ADC	advanced digital control; analog to digital converter	cm	centimeter	ext.	external
adj.	adjust, adjustment	CMOS	complementary metal oxide substrate (semiconductor)	F	Fahrenheit, female
ADV	advertising dimensional drawing	cogen.	cogeneration	fglass.	fiberglass
Ah	amp-hour	com	communications (port)	FHM	flat head machine (screw)
AHWT	anticipatory high water temperature	coml	commercial	fl. oz.	fluid ounce
AISI	American Iron and Steel Institute	Coml/Rec	Commercial/Recreational	flex.	flexible
ALOP	anticipatory low oil pressure	conn.	connection	freq.	frequency
alt.	alternator	cont.	continued	FS	full scale
Al	aluminum	CPVC	chlorinated polyvinyl chloride	ft.	foot, feet
ANSI	American National Standards Institute (formerly American Standards Association, ASA)	crit.	critical	ft. lb.	foot pounds (torque)
AO	anticipatory only	CRT	cathode ray tube	ft./min.	feet per minute
APDC	Air Pollution Control District	CSA	Canadian Standards Association	ftp	file transfer protocol
API	American Petroleum Institute	CT	current transformer	g	gram
approx.	approximate, approximately	Cu	copper	ga.	gauge (meters, wire size)
AQMD	Air Quality Management District	cUL	Canadian Underwriter's Laboratories	gal.	gallon
AR	as required, as requested	CUL	Canadian Underwriter's Laboratories	gen.	generator
AS	as supplied, as stated, as suggested	cu. in.	cubic inch	genset	generator set
ASE	American Society of Engineers	cw.	clockwise	GFI	ground fault interrupter
ASME	American Society of Mechanical Engineers	CWC	city water-cooled	GND, ⊕	ground
assy.	assembly	cyl.	cylinder	gov.	governor
ASTM	American Society for Testing Materials	D/A	digital to analog	gph	gallons per hour
ATDC	after top dead center	DAC	digital to analog converter	gpm	gallons per minute
ATS	automatic transfer switch	dB	decibel	gr.	grade, gross
auto.	automatic	dB(A)	decibel (A weighted)	GRD	equipment ground
aux.	auxiliary	DC	direct current	gr. wt.	gross weight
avg.	average	DCR	direct current resistance	H x W x D	height by width by depth
AVR	automatic voltage regulator	deg., °	degree	HC	hex cap
AWG	American Wire Gauge	dept.	department	HCHT	high cylinder head temperature
AWM	appliance wiring material	DFMEA	Design Failure Mode and Effects Analysis	HD	heavy duty
bat.	battery	dia.	diameter	HET	high exhaust temp., high engine temp.
BBDC	before bottom dead center	DI/EO	dual inlet/end outlet	hex	hexagon
BC	battery charger, battery charging	DIN	Deutsches Institut fur Normung e. V. (also Deutsche Industrie Normenausschuss)	Hg	mercury (element)
BCA	battery charging alternator	DIP	dual inline package	HH	hex head
BCI	Battery Council International	DPDT	double-pole, double-throw	HHC	hex head cap
BDC	before dead center	DS	disconnect switch	HP	horsepower
BHP	brake horsepower	DVR	digital voltage regulator	hr.	hour
blk.	black (paint color), block (engine)	E, emer.	emergency (power source)	HS	heat shrink
blk. htr.	block heater	ECM	electronic control module, engine control module	hsg.	housing
BMEP	brake mean effective pressure	EDI	electronic data interchange	HVAC	heating, ventilation, and air conditioning
bps	bits per second	EFR	emergency frequency relay	HWT	high water temperature
br.	brass	e.g.	for example ( <i>exempli gratia</i> )	Hz	hertz (cycles per second)
BTDC	before top dead center	EG	electronic governor	IC	integrated circuit
Btu	British thermal unit	EGSA	Electrical Generating Systems Association	ID	inside diameter, identification
Btu/min.	British thermal units per minute	EIA	Electronic Industries Association	IEC	International Electrotechnical Commission
C	Celsius, centigrade	EI/EO	end inlet/end outlet	IEEE	Institute of Electrical and Electronics Engineers
cal.	calorie	EMI	electromagnetic interference	IMS	improved motor starting
CAN	controller area network	emiss.	emission	in.	inch
CARB	California Air Resources Board	eng.	engine	in. H <sub>2</sub> O	inches of water
CB	circuit breaker	EPA	Environmental Protection Agency	in. Hg	inches of mercury
cc	cubic centimeter	ES	engineering special, engineered special	in. lb.	inch pounds
CCA	cold cranking amps	ESD	electrostatic discharge	Inc.	incorporated
ccw.	counterclockwise			ind.	industrial
CEC	Canadian Electrical Code			int.	internal
cert.	certificate, certification, certified			int./ext.	internal/external
cfh	cubic feet per hour			I/O	input/output
				IP	iron pipe
				ISO	International Organization for Standardization
				J	joule
				JIS	Japanese Industry Standard

k	kilo (1000)	MTBO	mean time between overhauls	rms	root mean square
K	kelvin	mtg.	mounting	rnd.	round
kA	kiloampere	MTU	Motoren-und Turbinen-Union	ROM	read only memory
KB	kilobyte (2 <sup>10</sup> bytes)	MW	megawatt	rot.	rotate, rotating
KBus	Kohler communication protocol	mW	milliwatt	rpm	revolutions per minute
kg	kilogram	μF	microfarad	RS	right side
kg/cm <sup>2</sup>	kilograms per square centimeter	N, norm.	normal (power source)	RTU	remote terminal unit
kgm	kilogram-meter	NA	not available, not applicable	RTV	room temperature vulcanization
kg/m <sup>3</sup>	kilograms per cubic meter	nat. gas	natural gas	RW	read/write
kHz	kilohertz	NBS	National Bureau of Standards	SAE	Society of Automotive Engineers
kJ	kilojoule	NC	normally closed	scfm	standard cubic feet per minute
km	kilometer	NEC	National Electrical Code	SCR	silicon controlled rectifier
kOhm, kΩ	kilo-ohm	NEMA	National Electrical Manufacturers Association	s, sec.	second
kPa	kilopascal	NFPA	National Fire Protection Association	SI	<i>Systeme international d'unites</i> , International System of Units
kph	kilometers per hour	Nm	newton meter	SI/EO	side in/end out
kV	kilovolt	NO	normally open	sil.	silencer
kVA	kilovolt ampere	no., nos.	number, numbers	SN	serial number
kVAR	kilovolt ampere reactive	NPS	National Pipe, Straight	SNMP	simple network management protocol
kW	kilowatt	NPSC	National Pipe, Straight-coupling	SPDT	single-pole, double-throw
kWh	kilowatt-hour	NPT	National Standard taper pipe thread per general use	SPST	single-pole, single-throw
kWm	kilowatt mechanical	NPTF	National Pipe, Taper-Fine	spec	specification
kWth	kilowatt-thermal	NR	not required, normal relay	specs	specification(s)
L	liter	ns	nanosecond	sq.	square
LAN	local area network	OC	overcrank	sq. cm	square centimeter
L x W x H	length by width by height	OD	outside diameter	sq. in.	square inch
lb.	pound, pounds	OEM	original equipment manufacturer	SS	stainless steel
lbm/ft <sup>3</sup>	pounds mass per cubic feet	OF	overfrequency	std.	standard
LCB	line circuit breaker	opt.	option, optional	stl.	steel
LCD	liquid crystal display	OS	oversize, overspeed	tach.	tachometer
ld. shd.	load shed	OSHA	Occupational Safety and Health Administration	TD	time delay
LED	light emitting diode	OV	overvoltage	TDC	top dead center
Lph	liters per hour	oz.	ounce	TDEC	time delay engine cooldown
Lpm	liters per minute	p., pp.	page, pages	TDEN	time delay emergency to normal
LOP	low oil pressure	PC	personal computer	TDES	time delay engine start
LP	liquefied petroleum	PCB	printed circuit board	TDNE	time delay normal to emergency
LPG	liquefied petroleum gas	pF	picofarad	TDOE	time delay off to emergency
LS	left side	PF	power factor	TDON	time delay off to normal
L <sub>wa</sub>	sound power level, A weighted	ph., ∅	phase	temp.	temperature
LWL	low water level	PHC	Phillips® head Crimptite® (screw)	term.	terminal
LWT	low water temperature	PHH	Phillips® hex head (screw)	THD	total harmonic distortion
m	meter, milli (1/1000)	PHM	pan head machine (screw)	TIF	telephone influence factor
M	mega (10 <sup>6</sup> when used with SI units), male	PLC	programmable logic control	TIR	total indicator reading
m <sup>3</sup>	cubic meter	PMG	permanent magnet generator	tol.	tolerance
m <sup>3</sup> /hr.	cubic meters per hour	pot	potentiometer, potential	turbo.	turbocharger
m <sup>3</sup> /min.	cubic meters per minute	ppm	parts per million	typ.	typical (same in multiple locations)
mA	milliampere	PROM	programmable read-only memory	UF	underfrequency
man.	manual	psi	pounds per square inch	UHF	ultrahigh frequency
max.	maximum	psig	pounds per square inch gauge	UL	Underwriter's Laboratories, Inc.
MB	megabyte (2 <sup>20</sup> bytes)	pt.	pint	UNC	unified coarse thread (was NC)
MCCB	molded-case circuit breaker	PTC	positive temperature coefficient	UNF	unified fine thread (was NF)
MCM	one thousand circular mils	PTO	power takeoff	univ.	universal
meggar	megohmmeter	PVC	polyvinyl chloride	US	undersize, underspeed
MHz	megahertz	qt.	quart, quarts	UV	ultraviolet, undervoltage
mi.	mile	qty.	quantity	V	volt
mil	one one-thousandth of an inch	R	replacement (emergency) power source	VAC	volts alternating current
min.	minimum, minute	rad.	radiator, radius	VAR	voltampere reactive
misc.	miscellaneous	RAM	random access memory	VDC	volts direct current
MJ	megajoule	RDO	relay driver output	VFD	vacuum fluorescent display
mJ	millijoule	ref.	reference	VGA	video graphics adapter
mm	millimeter	rem.	remote	VHF	very high frequency
mOhm, mΩ	milliohm	Res/Coml	Residential/Commercial	W	watt
MOhm, MΩ	megohm	RFI	radio frequency interference	WCR	withstand and closing rating
MOV	metal oxide varistor	RH	round head	w/	with
MPa	megapascal	RHM	round head machine (screw)	w/o	without
mpg	miles per gallon	rly.	relay	wt.	weight
mph	miles per hour			xfrm	transformer
MS	military standard				
ms	millisecond				
m/sec.	meters per second				
MTBF	mean time between failure				



**TP-6161 1/08f**

© 2004, 2005, 2006, 2007, 2008 by Kohler Co. All rights reserved.

# **KOHLER**<sup>®</sup> POWER SYSTEMS

KOHLER CO. Kohler, Wisconsin 53044  
Phone 920-565-3381, Fax 920-459-1646  
For the nearest sales/service outlet in the  
US and Canada, phone 1-800-544-2444  
KohlerPower.com

Kohler Power Systems  
Asia Pacific Headquarters  
7 Jurong Pier Road  
Singapore 619159  
Phone (65) 6264-6422, Fax (65) 6264-6455