

# **Water Specialist PR Control Valve Programming and Cover Drawing Manual**

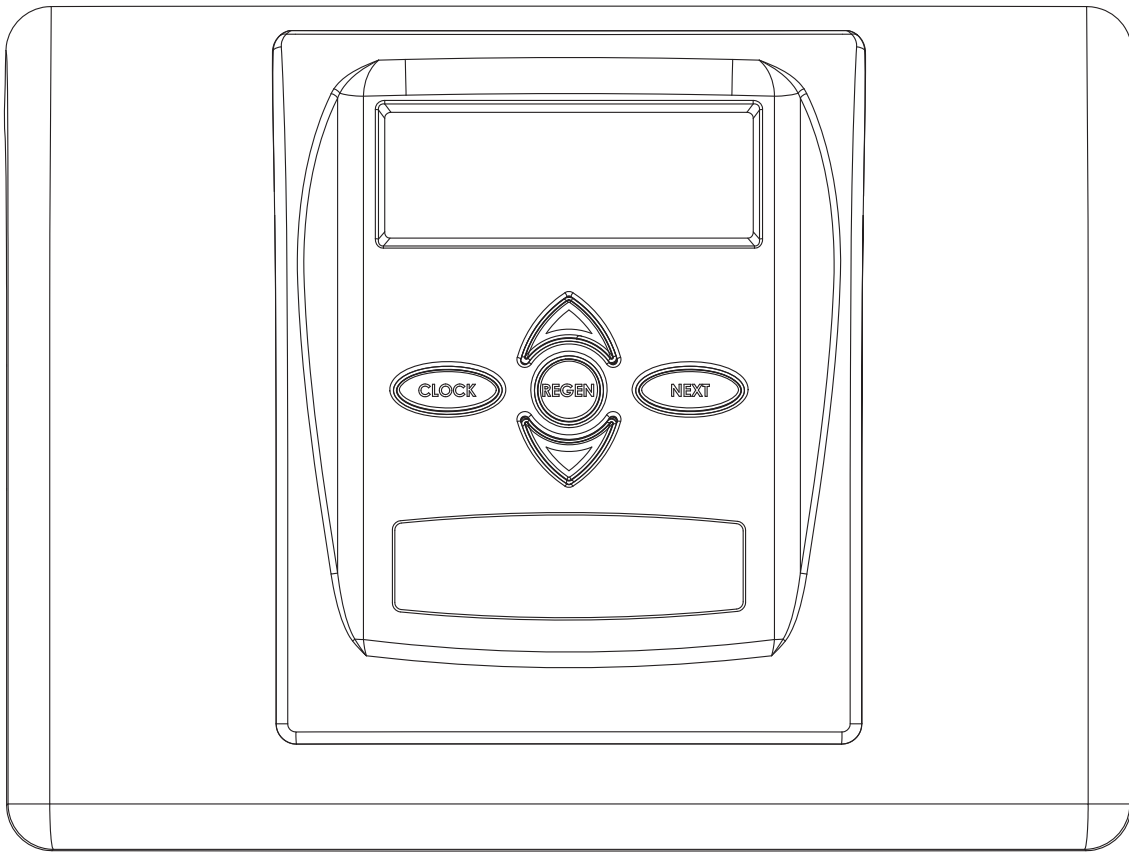



## Table of Contents

PR Front Cover and Drive Assembly.....	4
OEM General Programming Instructions .....	5
OEM Configuration Setup .....	7
OEM Softener System Setup .....	10
Setting Options Table.....	13
OEM Filter System Setup .....	14
Installer Display Settings .....	16
User Display Settings.....	17
Diagnostics.....	20
Valve History .....	21

### PR Front Cover and Drive Assembly

Drawing No.	Order No.	Description	Quantity
1	V3692-01PW	WS1LP FRONT COVER ASY PURITAN HSBY/BLK	1
2	V3107-01	WS1 MOTOR	1
3	V3106-01	WS1 DRIVE BRACKET & SPRING CLIP	1
4	V3757PR-BOARD	WS1THRU2L/2 PR PC BOARD REPLACE	1
5	V3110	WS1 DRIVE GEAR 12X36	3
6	V3109	WS1 DRIVE GEAR COVER	1
Not Shown	V3186	WS1 AC ADAPTER 110V-12V	1
	V3186EU	WS1 AC ADAPTER 220-240V-12V EU	
	V3186UK	WS1 AC ADAPTER 220-240V-12V UK	
	V3186-01	WS1 AC ADAPTER CORD ONLY	
Not Shown	V3690	WS1LP DRIVE BACK PLATE	1

Refer to Control Valve Service Manual for other drawings and part numbers.

Relay Specifications: 12V DC Relay with a coil resistance not less than 80 ohms. If mounting the relay under the cover check for proper mounting location dimensions on the backplate.

AC Adapter	U.S.	International
Supply Voltage	120 V AC	230V AC
Supply Frequency	60 Hz	50 Hz
Output Voltage	12 V AC	12 V AC
Output Current	500 mA	500 mA

Wiring For Correct On/Off Operation	
PC Board Relay Terminal Block	Relay
RELAY1	Coil -
COM	Coil +
RELAY2	Coil -

When replacing the battery, align positives and push down to fully seat.

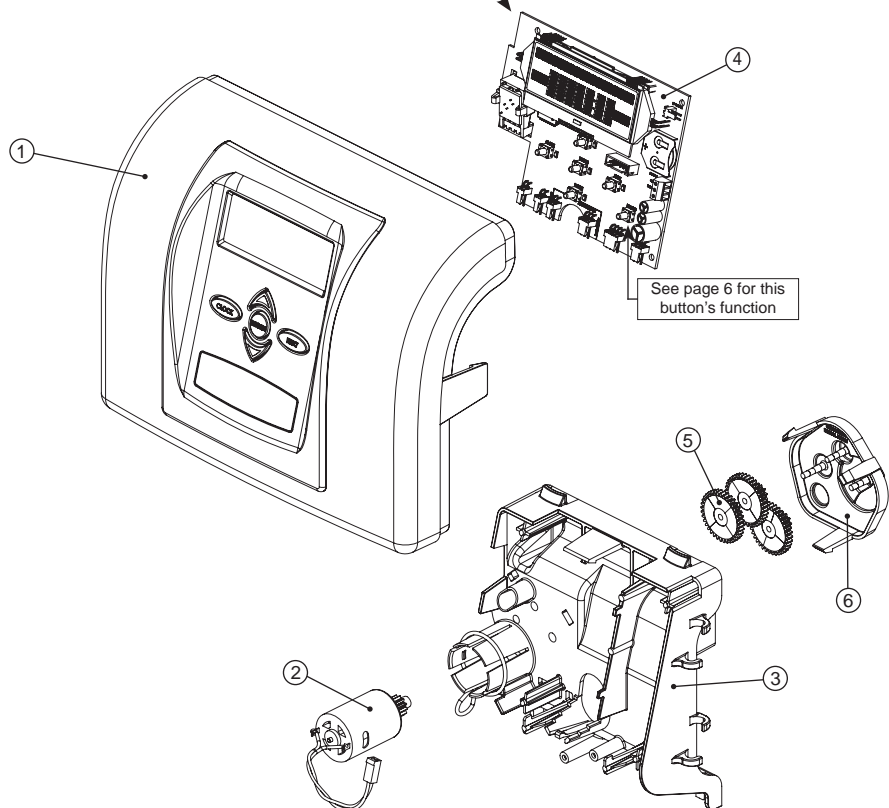
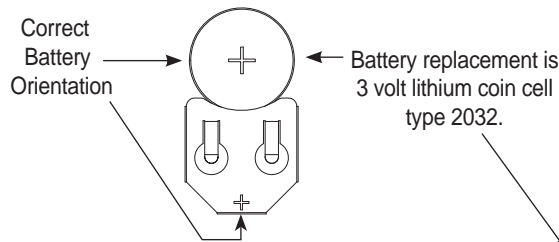
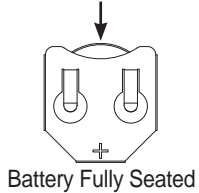

**OEM General Programming Instructions**

The control valve offers multiple procedures that allow the valve to be modified to suit the needs of the installation. These procedures are:

- OEM Configuration Setup
- OEM Softener System Setup
- OEM Filter System Setup
- Installer Display Settings
- User Display Settings
- Diagnostics
- Valve History

Tables 1 and 2 show cycle order when the valve is set up as a softener or filter.

**Table 1  
Regeneration Cycles Softening**

Downflow Regenerant Refill After Rinse	Downflow Regenerant Prefill	WS1PR only Upflow Regenerant Refill After Rinse	WS1PR only Upflow Regenerant Prefill
1 <sup>st</sup> Cycle: Backwash 2 <sup>nd</sup> Cycle: dn Brine 3 <sup>rd</sup> Cycle: Backwash 4 <sup>th</sup> Cycle: Rinse 5 <sup>th</sup> Cycle: Fill	1 <sup>st</sup> Cycle: Fill 2 <sup>nd</sup> Cycle: Softening 3 <sup>rd</sup> Cycle: Backwash 4 <sup>th</sup> Cycle: dn Brine 5 <sup>th</sup> Cycle: Rinse	1 <sup>st</sup> Cycle: UP Brine 2 <sup>nd</sup> Cycle: Backwash 3 <sup>rd</sup> Cycle: Rinse 4 <sup>th</sup> Cycle: Fill	1 <sup>st</sup> Cycle: Fill 2 <sup>nd</sup> Cycle: Softening 3 <sup>rd</sup> Cycle: UP Brine 4 <sup>th</sup> Cycle: Backwash 5 <sup>th</sup> Cycle: Rinse

**Table 2  
Regeneration Cycles Filtering**

Downflow Regenerant Refill After Rinse	No Regenerant
1 <sup>st</sup> Cycle: Backwash 2 <sup>nd</sup> Cycle: dn Regenerant Draw 3 <sup>rd</sup> Cycle: Backwash 4 <sup>th</sup> Cycle: Rinse 5 <sup>th</sup> Cycle: Fill	1 <sup>st</sup> Cycle: Backwash 2 <sup>nd</sup> Cycle: Rinse

The control valve with a water meter can be set for Demand Initiated Regeneration (DIR) only, Time Clock operation only or DIR and Time Clock which ever comes first, depending upon what settings are selected for Day Override and Gallon Capacity.<sup>1</sup> See Table 3.

If a control valve does not contain a meter, the valve can only act as a time clock, and day override should be set to any number and gallon capacity should be set to off.

**Table 3  
DIR/Time Clock Options**

DIR	Time Clock	Reserve Capacity	Softener	Filter		Settings <sup>2</sup>	
				Regenerant	Backwash Only	Days to REGEN	Gallon Capacity
Yes		Automatically calculated	Yes			Off	Auto
Yes		If desired enter a value less than estimated capacity	Yes	Yes	Yes	Off	Any Number
Yes	Yes	Automatically calculated	Yes			Any Number	Auto
Yes	Yes	If desired enter a value less than estimated capacity	Yes	Yes	Yes	Any Number	Any number
	Yes	None	Yes	Yes	Yes	Any Number	Off

For DIR Softeners, there are two options for setting the Gallons Capacity. The Gallons Capacity is automatically calculated if set to AUTO. Reserve Capacity is automatically estimated based on water usage if AUTO is used. The other option is to set the Gallons Capacity to a specific number. If a specific number is set, reserve capacity is zero, unless the value is manually set (i.e. the manufacturer intentionally sets the gallon capacity number below the calculated capacity of the system).

A unique feature of this control valve is the ability to display actual water usage for the last 63 days. The values are initially stored as “----”. This means the value is unknown. As days pass values are stored as “0” for no flow or the actual number of gallons. The counting of the gallons starts at the regeneration time. If no regeneration time can be set (i.e. when the valve is set for immediate regeneration) the counting of gallons starts at 12 a.m. Day 1 is yesterday, day 2 the day before yesterday, etc. As new values are added the oldest history disappears.

Another unique feature is that the valve automatically calculates a reserve capacity when set up as a softener with “Gallons Capacity” set to “AUTO” and the “Regeneration Time Option” set to “DELAY REGEN” or “DELAY + IMMEDIATE”. The actual reserve capacity is compared to the gallons capacity remaining immediately prior to the preset regeneration time. A regeneration will occur if the actual reserve capacity is less than the gallons capacity remaining. The actual reserve capacity is calculated by using the estimated reserve capacity and adjusting it up or down for actual usage.

The estimated reserve capacity for a given day of the week is the maximum value stored for the last three non-trivial water usages (i.e. more than 20 gallons/day) in seven day intervals.

<sup>1</sup> See Installer Display Settings, OEM Softener System Setup and OEM Filter System Setup for explanations of Day Override and Gallon Capacity.

<sup>2</sup> Days to REGEN and Gallon Capacity can not both be set to “OFF” at the same time.

To “lock out” access to diagnostic and valve history displays and modifications to settings except hardness, day override, time of regeneration and time of day by anyone but the manufacturer, press ▼, NEXT, ▲, and CLOCK in sequence after settings are made. To “unlock”, so other displays can be viewed and changes can be made, press ▼, NEXT, ▲, and CLOCK in sequence.

When in operation normal user displays such as time of day, volume remaining before regeneration, present flow rate or days remaining before regeneration are shown. When stepping through a procedure, if no buttons are pressed within five minutes, the display returns to a normal user display. Any changes made prior to the five minute time out are incorporated.

To quickly exit OEM Softener Setup, OEM Filter Setup, OEM Configuration Setup, Installer Display Settings, Diagnostics or Valve History press CLOCK. Any changes made prior to the exit are incorporated.

To clear the Service Call reminder, press the ▲ and ▼ buttons simultaneously while CALL is displayed.

**When desired, all information in Diagnostics, the Program and User Settings may be reset to defaults when the valve is installed in a new location. To reset, press NEXT and ▼ buttons simultaneously to go to the Softening/Filtering Type screen. Press ▲ and ▼ simultaneously to reset Diagnostics to zero and the Program and User Settings to defaults. The time will be reset to 12:00 P.M.**

Sometimes it is desirable to have the valve initiate and complete two regenerations within 24 hours and then return to the preset regeneration procedure. It is possible to do a double regeneration if the control valve is set to “DELAYED REGEN” or “DELAY + IMMEDIATE” in OEM Softener System Setup or OEM Filter System Setup. To do a double regeneration:

1. Press the “REGEN” button once. REGEN TODAY will flash on the display.
2. Press and hold the “REGEN” button for three seconds until the valve regeneration initiates.

Once the valve has completed the immediate regeneration, the valve will regenerate one more time at the preset regeneration time.

### Proportional Brining

If the system is set up as a prefill 1” upflow softener the control valve can also be set to normal or proportional brining.

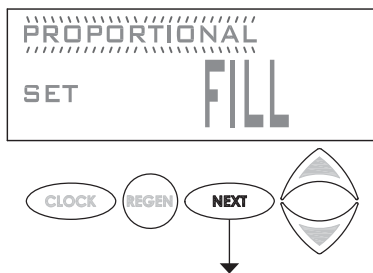

This step will appear after Step 7S and before Step 8S if the system is set up as a prefill upflow softener. The following options can be selected:

- NORMAL FILL - System always prefills with the salt level selected.
- PROPORTIONAL FILL - If proportional brining is selected, the actual salt fill time will be calculated by dividing the actual volume of treated water used by the full volumetric capacity, then multiplying this value by the maximum salt fill time.

Press NEXT to go to the next step. Press REGEN to return to the previous step.

### Backlight Control

As an energy-saving feature, the control will automatically turn off the display illumination after 5 minutes of keypad inactivity, or ½ minute after the last use of treated water. Any further keypad activity or water use will re-illuminate the display for ½ or 5 minutes. The Energy Saver feature default is ON.

The Master Illumination button is located in the lower right hand portion of the board. The purpose of the button is to manage the keypad backlights and the Energy Saver feature. When the keypad backlights are OFF, pressing and holding this button for about 5 seconds will turn the lights ON, and turn the energy-saver feature OFF, which will be indicated with a display “ENERGY SAVER OFF”. If the button is not held until the Energy Saver Off display is shown, the backlights for the display and the keypad will both go OFF after 5 minutes of no keypad activity. (The keypad backlights will remain OFF until either the Master Illumination or any keypad button is pressed to turn them back ON.)

## OEM Configuration Setup

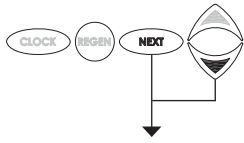
**STEP 1CS**

**Step 1CS** – Press NEXT and ▼ simultaneously for 3 seconds and release. Then press NEXT and ▼ simultaneously for 3 seconds and release. If screen in Step 2CS does not appear in 5 seconds the lock on the valve is activated. To unlock press ▼, NEXT, ▲, and CLOCK in sequence, then press NEXT and ▼ simultaneously for 3 seconds and release. Then press NEXT and ▼ simultaneously for 3 seconds and release.

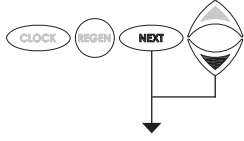
**STEP 2CS**

**Step 2CS** – Use the ▲ or ▼ to select 1.0 for 1” valve, 1.25 for 1.25” valve, 1.5 for 1.5” valve, 2.0L for 2L valve or 2.0 for 2” valve<sup>3</sup>. When 2.0L or 2.0 is selected, an additional screen will appear. It is used to select which size flow meter is to be used with the valve, 1.5, 2.0 or Variable Meter Calibration. When the Variable Meter feature is selected, enter the desired number of pulses per gallon that the flow meter will generate. Press NEXT to go to Step 3CS. Press REGEN to exit OEM cycle sequence.

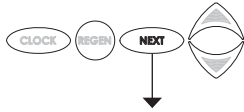
**STEP 3CS**

**Step 3CS** – When 2.0L or 2.0 are selected, an additional screen will appear. It is used to select which size flow meter is to be used with the valve, 1.5 or 2.0. Variable meter pulses of 0.1-150.0 PPG can also be selected. Press NEXT to go to Step 4CS. Press REGEN to return to previous step.

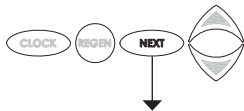

**Note:** When using the WS2 valve, if “2.0L” is set instead of “2.0”, when the valve is in regeneration and the piston drives to the “DRAW” cycle the piston will stall and generate a 102 error code. Clear the error code by pressing “NEXT” and “REGEN” buttons simultaneously until the valve resets, then re-program valve to proper valve type setting.

<sup>3</sup>When using the WS2 control valve, the circuit board software must have valve selection choices of 2.0 and 2.0L. The WS2 valve must be set for the 2.0 valve type during programming. If the software version does not have both the 2.0 and 2.0L selections, consult your equipment supplier for a replacement circuit board. When using the WS2L valve with older version software that does not have both 2.0 and 2.0L selection choices, the valve must be set to 2.0 during programming. If a WS2L valve is being used with newer version software that has both 2.0 and 2.0L selection choices, the valve must be set to 2.0L during programming.

**STEP 4CS**



Step 4CS - Allows selection of one of the following using the ▲ or ▼ buttons:

- the Control Valve to have no hard water bypass;
  - the Control Valve to act as an alternator; or
  - the Control Valve to have a separate source during the regeneration cycle.
- Select OFF when neither of these features are used.

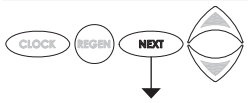

Only use Clack No Hard Water Bypass Valves or Clack Motorized Alternating Valves (MAV) with these selections. Clack No Hard Water Bypass Valves (1" or 1.25" V3070FF or V3070FM) are not designed to be used with the alternator or separate source functions. The V3063 and V3063BSPT motorized alternating valves are not designed to be used as a no hard water bypass or separate source inlet if the pressure differential is more than 60 psi.

Configuring the Control Valve for No Hard Water Bypass Operation:

Select nHbP for control operation. For no hard water bypass operation the three wire connector is not used.

Selection requires that a connection to MAV or a Clack No Hard Water Bypass Valve is made to the two pin connector labeled MAV MTR located on the printed circuit board. If using a MAV, the A port of the MAV must be plugged and the valve outlet connected to the B port. When set to nHbP the MAV will be driven closed before the first regeneration cycle that is not FILL or SOFTENING or FILTERING, and be driven open after the last regeneration cycle that is not FILL.



NOTE: If the control valve enters into an error state during regeneration mode, the no hard water bypass valve will remain in its current state until the error is corrected and reset.

Selecting the Control Valve to act as an alternator:

Prior to starting the programming steps, connect the three pin wire to each control valve board's three pin connector labeled "INTERCONNECT". Also connect the meter cord to either control valve to the three pin connector labeled "METER INPUT".			
Softener Valve Programming Steps			
OEM Cycle Sequence	Step 4CS	Set to ALTA Connect ALTA valve to the MAV's A port and connect the MAV's two pin wire connector to the two pin connector labeled "MAV MTR" on the ALTA valve	Set to ALTB Connect ALTB valve to the MAV's B port. No connections between the ALTB valve and the MAV are made.
Softener System Setup	Step 8S	Set to "AUTO"	Set to "AUTO"
Softener System Setup	Step 9S	Set regeneration time option to "IMMEDIATE".	Set regeneration time option to "IMMEDIATE".
Installer Display Setting	Step 3I	Set Days Between Regen to "OFF"	Set Days Between Regen to "OFF"

If set up for a filter, in Step 7F set Volume Capacity; in Step 9S select Regeneration Time Option "IMMEDIATE"; and in Step 3I select Days Between Regen "OFF".

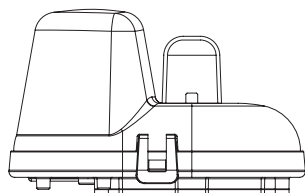

**Retracted**

Valve "A" in Service Position = MAV piston rod Retracted

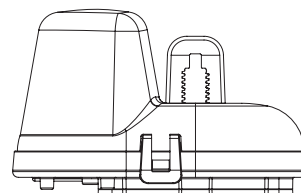

**Extended**

Valve "B" in Service Position = MAV piston rod Extended

**Note: Clack Twin Alternator Operations**

- Twin alternating systems can be programmed with a day override setting combined with the normal volume-based regeneration programming. A twin alternating system in this configuration will then regenerate based on the volume used or the day override if there is a period of low water usage.
- Twin alternating systems can be programmed as a time clock only based regenerating system. In this configuration, the days remaining are counted only on the unit that is in service. The unit in Stand-by Mode only notes days in diagnostics, which results in time clock only twin regeneration initiation.
- Twin alternating systems can be programmed for a delayed regeneration time. The system will allow an immediate transfer of the MAV to switch tanks and place a fully regenerated unit in service once a unit becomes exhausted. The exhausted unit will then be placed into Stand-by Mode and allowed to have a delayed regeneration at the pre-set time.



NOTE: If the control valve is in an error state during regeneration mode the MAV will close the B port and keep open the A port until the error is corrected and reset.

For Clack Corporation alternator systems using the WS1, WS1.25, WS1.5 and WS2L valves, there will be an option to delay the last two steps of regeneration (Rinse and Fill) until just prior to a return to Service. Upon completion of the initial regeneration steps, the valve will enter Standby. If the Delayed Rinse and Fill is not set to ON, the regeneration will proceed normally, without any delays between cycles.

For Clack Corporation alternator systems using the WS2 valve, when NEXT is pressed after selecting ALTA or ALTb, a display will allow the user to set the amount of pre-service rinse time for the stand by tank just prior to returning to service.

Configuring the Control Valve for Separate Source Operation:

Select Separate Source Enabled for control operation. For separate source operation the three wire connector is not used.

Selection requires that a connection to a Clack Motorized Alternator Valve (MAV) is made to the two pin connector labeled MAV MTR located on the printed circuit board. The C port of the MAV must be connected to the valve inlet and the A port connected to the separate source used during regeneration. The B port must be connected to the feed water supply.

When set to Separate Source Enabled the MAV will be driven closed before the first regeneration cycle, and be driven open after the last regeneration cycle.

NOTE: If the control valve enters into an error state during regeneration mode, the MAV will remain in its current state until the error is corrected and reset.

Press NEXT to go to Step 5CS. Press REGEN to return to previous step.

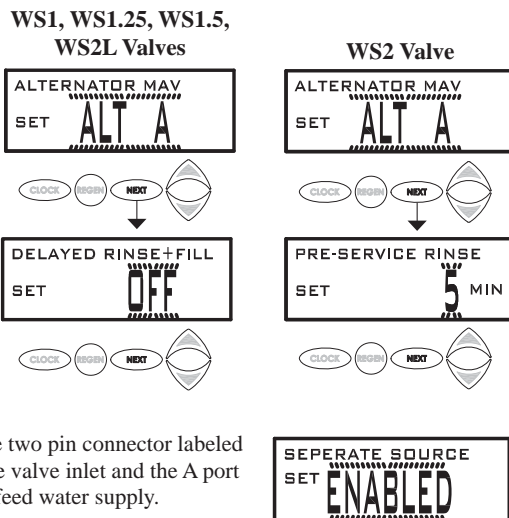

**Step 5CS** – Set Aux MAV Output to operate in one of three modes:

TIME – Output is activated at a set time after the start of regeneration, for a specified length of time.

SEP SOURCE: Allows Auxiliary MAV to switch positions before the start of regeneration and then switch back at the end of regeneration.

OFF – Deactivates this output.

Press NEXT to go to Step 6CS. Press REGEN to return to previous step.

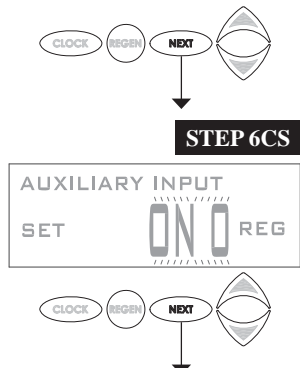

**Step 6CS** – Allows selection of an outside signal to control the initiation of a regeneration. Selection only matters if a connection is made to the two pin connector labeled DP SWITCH located on the printed circuit board.

OFF – Feature not used

NOTE: In a twin alternating system each control must have a separate dP signal or dP switch. One dP signal or one dP switch cannot be used for both controls.

ON 0 REG – If the dP switch is closed for an accumulative time of 2 minutes a regeneration will be signaled to the unit. In a twin alternating system the MAV will transition first to switch units so that the signaled unit can start regeneration. After the MAV is fully transitioned the regeneration begins immediately. Note: For WS1 – WS2L control valves programmed for twin alternating: if the dP function “ON 0 REG” is set, the Delayed Rinse and Fill feature is not available.

DELAY REG – If the dP switch is closed for an accumulative time of 2 minutes a regeneration will occur at the scheduled delayed regeneration time. In a twin alternating system once the dP switch is triggered the PC Board will display “REGEN TODAY” and when the delayed regen time comes the control will switch tanks and the triggered unit will then go into regeneration.

Note: For WS1 – WS2L control valves programmed for twin alternating: if the dP function “DELAY REG” is set, the Delayed Rinse and Fill feature is not available.

HOLD REG – If the dP switch is closed a regeneration will be prevented from occurring while there is switch closure. In a twin alternating system the regeneration of a unit can be prevented upon switch closure. If the unit depletes the capacity down to zero it will not be allowed to switch tanks to regenerate until the switch is open. Note: For WS1 – WS2L control valves programmed for twin alternating the Delayed Rinse and Fill feature can be set in conjunction with the “HOLD REG” if desired.

Press NEXT to go to Step 7CS. Press REGEN to return to previous step.

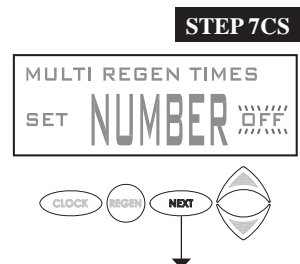

**Step 7CS** – Multiple Regenerations: Set the number of regenerations that will occur on the day of regeneration.

When this feature is active, two to four regeneration cycle times are possible on the scheduled multi-regeneration day. Multi-regeneration days are determined by the number of days set in the Day Between Regen Setting (Step 3D). OFF will cancel this feature and limit the amount of Regen Times to one. Display is only viewed if Step 9S or 5F is set to off.

Press NEXT exit Configuration Setup. Press REGEN to return to previous step.

OEM Softener System Setup

Softening Cycle Programs	Fill	Soft	BW	Draw UP	Draw DN	BW	Rinse	Fill
SOFTENING DN POST			X		X	X	X	X
SOFTENING DN PRE	X	X	X		X		X	
SOFTENING UP POST (1" Valve only)				X		X	X	X
SOFTENING UP PRE (1" Valve Only)	X	X		X		X	X	

Cycle	Units	Range	Default
Backwash	Minutes	1-120 or OFF	8
Rinse	Minutes	1-120 or OFF	4
Draw (UP or DN)	Minutes	1-180 or OFF	60
Fill (all except 2" valve)	LBS	0.1-200.0 or OFF	9.5
Softening	Minutes	1-480 or OFF	240
Fill (2" valve)	Minutes	01.-99.0 or OFF	6.0

If a 1" upflow control valve is programmed for prefill the proportional brining display will appear after the grains capacity display. (Step 7S).

**STEP 1S**

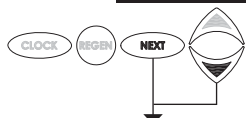

**Step 1S** – Press NEXT and ▼ simultaneously for 3 seconds and release. If screen in Step 2S does not appear in 5 seconds the lock on the valve is activated. To unlock press ▼, NEXT, ▲, and CLOCK in sequence, then press NEXT and ▼ simultaneously for 3 seconds and release.

**STEP 2S**



**Step 2S** – Choose the SOFTENING program desired (see table) using the ▼ or ▲ button. Press NEXT to go to Step 3S. Press REGEN to exit OEM Softener System Setup.



**STEP 3S**



**Step 3S** – Select the time for the first cycle using the ▼ or ▲ button. Press NEXT to go to Step 4S. Press REGEN to return to previous step.



**STEP 4S**



**Step 4S** – Select the time for the second cycle using the ▼ or ▲ button. Press NEXT to go to Step 5S. Press REGEN to return to previous step.



**STEP 5S**



**Step 5S** – Select time for the third cycle using the ▼ or ▲ button. Press NEXT to go to Step 6S. Press REGEN to return to previous step.



**STEP 6S**



**Step 6S** – Select the time for the fourth cycle using the ▼ or ▲ button. Press NEXT to go to Step 7S. Press REGEN to return to previous step.



**STEP 7S**

FILL	9.5	LBS
SET		

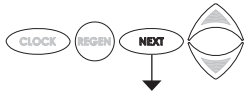

**Step 7S** – Select the LBS or MIN for the fifth cycle using the ▼ or ▲ button. When 2.0 is selected in Step 2CS, FILL is on minutes. WS2 valves are shipped from the factory with a refill flow control of 2.2 gpm (8.3 lpm). Press NEXT to go to Step 8S. Press REGEN to return to previous step.

**STEP 8S**

GRAINS OF CAPACITY	24.0	X1K
SET		

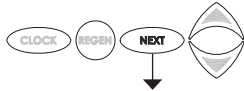

**Step 8S** –Set Grains Capacity using the ▲ or ▼ button. The ion exchange capacity is in grains of hardness as calcium carbonate for the system based on the pounds of salt that will be used. Calculate the pounds of salt using the fill time previously selected. Grains capacity is affected by the fill time. The grains capacity for the selected fill time should be confirmed by OEM testing. The capacity and hardness levels entered are used to automatically calculate reserve capacity when gallon capacity is set to AUTO. Press NEXT to go to Step 9S. Press REGEN to return to previous step.

**STEP 9S**

RESERVE CALCULATOR	AUTO	GAL
SET		

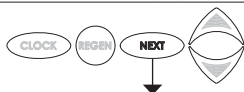

**Step 9S** – Set Volume Capacity using the ▲ or ▼ button. If value is set to:

- “AUTO” capacity will be automatically calculated and reserve capacity will be automatically estimated;
- “OFF” regeneration will be based solely on the day override set (see Installer Display Settings Step 3I); or
- “GALS BETWEEN REGEN” regeneration will be based off the value specified.

If “OFF” or a number is used, hardness display will not be allowed to be set in Installer Display Settings Step 2I. See Setting Options Table for more detail. Press NEXT to go to Step 10S. Press REGEN to return to previous step.

**STEP 10S**

DELAY+IMMEDIATE	REGEN
SET	



**Step 10S** – Set Regeneration Time Options using the ▲ or ▼ button. If value is set to:

- “DELAYED REGEN” means regeneration will occur at the preset time;
- “IMMEDIATE” means regeneration will occur immediately when the volume capacity reaches 0 (zero); or
- “DELAY + IMMEDIATE” means regeneration will occur at one of the following:
  - the preset time when the volume capacity falls below the reserve or the specified number of days between regenerations is reached whichever comes first; or
  - immediately after 10 minutes of no water usage when the volume capacity reaches 0 (zero).

See Setting Options Table for more detail. This screen is not viewed if Step 8S is set to OFF. Press NEXT to go to Step 11S. Press REGEN to return to previous step.

**STEP 11S**

RELAY 1 OFF	MODE
SET	



**Step 11S:** Set Relay 1 MODE operation using the ▲ or ▼ button. The choices are:

TIME: Relay activates at a set time after the start of a regeneration and then deactivates after a set period of time.

GALLONS: Relay activates after a set number of gallons have been used while in service, for a preset duration of time.

REGEN GAL: Relay activates every set number of gallons have been used while in service or during regeneration for a preset duration of time.

OFF: Deactivates this output.

Press NEXT to go to Step 12S. Press REGEN to return to previous step.

**STEP 12S**

RELAY 2 OFF	MODE
SET	

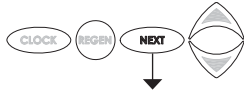

**Step 12S:** Set Relay 2 MODE operation using the ▲ or ▼ button. The choices are:

TIME: Relay activates at a set time after the start of a regeneration and then deactivates after a set period of time.

GALLONS: Relay activates after a set number of gallons have been used while in service, for a preset duration of time.

REGEN GAL: Relay activates every set number of gallons have been used while in service or during regeneration for a preset duration of time.

OFF: Deactivates this output.

Press NEXT to go to Step 13S. Press REGEN to return to previous step.

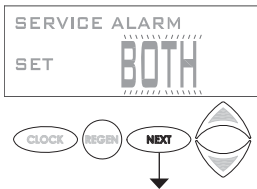
**STEP 13S**

**Step 13S:** Set scheduled service alarm using the ▲ or ▼. Available options are OFF, TIME, ON GAL or BOTH. Selecting OFF disables this feature. If OFF is selected press NEXT to exit OEM System Setup. If TIME, ON GAL or BOTH is selected press NEXT to select the TIME and/or ON GAL values. See Steps 14S and/or 15S. Press REGEN to return to the previous step.

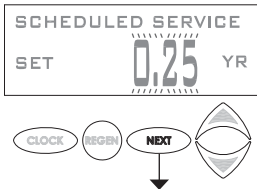
**STEP 14S**

**Step 14S:** Status display – Time remaining until Service Alarm generation. Only appears if TIME or BOTH is set in Step 13S. To change duration time, press and hold the ▲ and ▼ buttons for about 3 seconds until SET appears, and the number flashes. Use ▲ or ▼ to select the new value. Press NEXT to either exit OEM Softener System Setup or go to Step 15S if BOTH was selected in Step 13S. Press REGEN to return to the previous step.

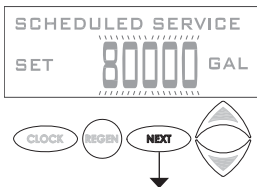
**STEP 15S**

**Step 15S:** Status display – Volume remaining until Service Alarm generation. Only appears if GAL or BOTH is set in Step 13S. To change the volume between service calls, press and hold the ▲ and ▼ buttons for about 3 seconds until SET appears, and the number flashes. Use ▲ or ▼ to select the new value. Press NEXT to exit OEM Softener System Setup. Press REGEN to return to the previous step.

**RETURN TO NORMAL MODE**

**Setting Options Table**  
Filters should only use shaded options.

Volume Capacity	Regeneration Time Option	Day Override	Result <sup>3</sup>
AUTO	DELAYED REGEN	OFF	Reserve capacity automatically estimated. Regeneration occurs when volume capacity falls below the reserve capacity at the next Regen Set Time
AUTO	DELAYED REGEN	Any number	Reserve capacity automatically estimated. Regeneration occurs at the next Regen Set Time when volume capacity falls below the reserve capacity or the specified number of days between regenerations is reached.
Any number	DELAYED REGEN	OFF	Reserve capacity <u>not</u> automatically estimated. Regeneration occurs at the next Regen Set Time when volume capacity reaches 0.
OFF	DELAYED REGEN	Any number	Reserve capacity <u>not</u> automatically estimated. Regeneration occurs at the next Regen Set Time when the specified number of days between regenerations is reached.
Any number	DELAYED REGEN	Any number	Reserve capacity <u>not</u> automatically estimated. Regeneration occurs at the next Regen Set Time when volume capacity reaches 0 or the specified number of days between regenerations is reached.
AUTO	IMMEDIATE	OFF	Reserve capacity <u>not</u> automatically estimated. Regeneration occurs immediately when volume capacity reaches 0. Time of regeneration will not be allowed to be set because regeneration will always occur when volume capacity reaches 0.
Any number	IMMEDIATE	OFF	Reserve capacity <u>not</u> automatically estimated. Regeneration occurs immediately when volume capacity reaches 0. Time of regeneration will not be allowed to be set because regeneration will always occur when volume capacity reaches 0.
AUTO	DELAY + IMMEDIATE	OFF	Reserve capacity automatically estimated. Regeneration occurs when volume capacity falls below the reserve capacity at the next Regen Set Time or regeneration occurs after 10 minutes of no water usage when volume capacity reaches 0.
AUTO	DELAY + IMMEDIATE	Any number	Reserve capacity automatically estimated. Regeneration occurs at the next Regen Set Time when volume capacity falls below the reserve capacity or the specified number of days between regenerations is reached or regeneration occurs after 10 minutes of no water usage when volume capacity reaches 0.
Any number	DELAY + IMMEDIATE	Any number	Reserve capacity <u>not</u> automatically estimated. Regeneration occurs at the next Regen Set Time when the specified number of days between regenerations is reached or regeneration occurs after 10 minutes of no water usage when volume capacity reaches 0.

<sup>3</sup> Reserve capacity estimate is based on history of water usage

OEM Filter System Setup

Filtering Cycle Programs	BW	Draw DN	BW	Rinse	Fill
FILTERING DN POST	X	X	X	X	X
FILTERING BW/RINSE			X	X	

Cycle	Units	Range	Default
Backwash	Minutes	1-120 or OFF	8
Rinse	Minutes	1-120 or OFF	4
Draw (DN)	Minutes	1-180 or OFF	60
Fill (all except 2" valve)	Gallons	0.01-20.00 or OFF	0.95
Fill (2" valve)	Minutes	01.-99.0 or OFF	6.0

**STEP 1F**

**Step 1F** – Press NEXT and ▼ simultaneously for 3 seconds and release. If screen in Step 2F does not appear in 5 seconds the lock on the valve is activated. To unlock press ▼, NEXT, ▲, and CLOCK in sequence, then press NEXT and ▼ simultaneously for 3 seconds and release.

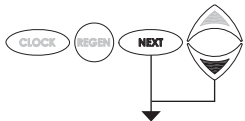

**STEP 2F**

**Step 2F** – Choose the FILTERING program desired using the ▼ or ▲ buttons. Press NEXT to go to Step 3F. Press REGEN to exit OEM Filter System Setup.

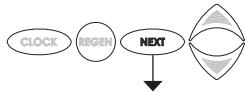

**STEP 3F**

**Step 3F** – Select the time for the first cycle (which in this example is BACKWASH) using the ▼ or ▲ button. Press NEXT to go to Step 4F. Press REGEN to return to previous step.

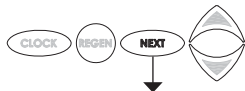

**STEP 4F**

**Step 4F** – Select the time for the second cycle (which in this example is RINSE) using the ▼ or ▲ button. Press NEXT to go to Step 5F. Press REGEN to return to previous step.



**STEP 5F**

**Step 5F** – Set Volume Capacity using the ▼ or ▲ button. If value is set to:

- “OFF” regeneration will be based solely on the day override set (see Installer Display/Settings Step 3I); or
- As a number, regeneration initiation will be based off the value specified.

See Setting Options Table for more detail. Press NEXT to go to Step 6F. Press REGEN to return to previous step.

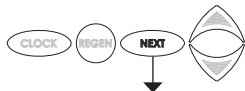

**STEP 6F**

**Step 6F** – Set Regeneration Time Options using the ▼ or ▲ button. If value is set to:

- “DELAYED REGEN” means regeneration will occur at the preset time;
- “IMMEDIATE” means regeneration will occur immediately when the volume capacity reaches 0 (zero); or
- “DELAY + IMMEDIATE” means regeneration will occur at one of the following:
  - the preset time when the volume capacity falls below the reserve or the specified number of days between regenerations is reached whichever comes first; or
  - immediately after 10 minutes of no water usage when the volume capacity reaches 0 (zero).

See Setting Options Table for more detail. Press NEXT to go to Step 7F. Press REGEN to return to previous step.

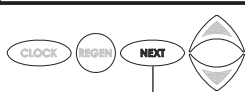

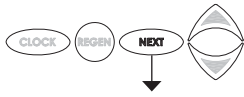
**STEP 7F**

**Step 7F** – Set Relay 1 MODE operation using the ▼ or ▲ button. The choices are:

**TIME:** Relay activates at a set time after the start of a regeneration and then deactivates after a set period of time.

**GALLONS:** Relay activates after a set number of gallons have been used while in service, for a preset duration of time.

**REGEN GAL:** Relay activates every set number of gallons have been used while in service or during regeneration for a preset duration of time.

**OFF:** Deactivates this output.

Press NEXT to go to Step 8F. Press REGEN to return to previous step.

**STEP 8F**

**Step 8F** – Set Relay 2 MODE operation using the ▼ or ▲ button. The choices are:

**TIME:** Relay activates at a set time after the start of a regeneration and then deactivates after a set period of time.

**GALLONS:** Relay activates after a set number of gallons have been used while in service, for a preset duration of time.

**REGEN GAL:** Relay activates every set number of gallons have been used while in service or during regeneration for a preset duration of time.

**OFF:** Deactivates this output.

Press NEXT to go to Step 9F. Press REGEN to return to previous step.

**STEP 9F**

**Step 9F** – Set scheduled service alarm using the ▼ or ▲. Available options are OFF, TIME, ON GAL or BOTH.

Selecting OFF disables this feature. If OFF is selected press NEXT to exit OEM System Setup. If TIME, ON GAL or BOTH is selected press NEXT to select the TIME and/or ON GAL values. See Steps 10F and/or 11F. Press REGEN to return to the previous step.

**STEP 10F**

**Step 10F** – Status display – Time remaining until Service Alarm generation. Only appears if TIME or BOTH are set in Step 9F. To change duration time, press and hold the ▼ and ▲ buttons for about 3 seconds until SET appears, and the number flashes. Use ▼ or ▲ to select the new value. Press NEXT to either exit OEM Filter System Setup or go to Step 11F if BOTH was selected in Step 9F. Press REGEN to return to the previous step.

**STEP 11F**

**Step 11F** – Status display – Volume remaining until Service Alarm generation. Only appears if GAL or BOTH are set in Step 9F. To change the volume between service calls, press and hold the ▼ and ▲ buttons for about 3 seconds until SET appears, and the number flashes. Use ▼ or ▲ to select the new value. Press NEXT to exit OEM Filter System Setup. Press REGEN to return to the previous step.

### Installer Display Settings

#### STEP 1I

**STEP 1I** - Press NEXT and ▲ simultaneously for 3 seconds.

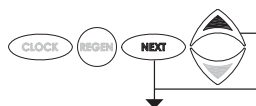

#### STEP 2I

**STEP 2I** – Hardness: Set the amount of hardness in grains of hardness as calcium carbonate per gallon using the ▲ or ▼ buttons. The default is 20 with value ranges from 1 to 150 in 1 grain increments. Note: The grains per gallon can be increased if soluble iron needs to be reduced. This display will not show if “FILTER” is selected in Step 2F or if ‘AUTO’ is not selected in Set Volume Capacity in OEM Softener System Setup. Press NEXT to go to step 3I. Press REGEN to exit Installer Display Settings.



#### STEP 3I

**STEP 3I** – Day Override: When volume capacity is set to “OFF”, sets the number of days between regenerations. When volume capacity is set to AUTO or to a number, sets the maximum number of days between regenerations. If value set to “OFF”, regeneration initiation is based solely on volume used. If value is set as a number (allowable range from 1 to 28) a regeneration initiation will be called for on that day even if sufficient volume of water were not used to call for a regeneration. Set Day Override using ▲ or ▼ buttons:

- number of days between regeneration (1 to 28); or
- “OFF”.

See Setting Options Table for more detail on setup. Press NEXT to go to step 4I. Press REGEN to return to previous step.



#### STEP 4I

**STEP 4I** – Next Regeneration Time (hour): Set the hour of day for regeneration using ▲ or ▼ buttons. AM/PM toggles after 12. The default time is 2:00 AM. This display will show “REGEN IMMEDIATE ON ZERO GAL” if “IMMEDIATE” is selected in Set Regeneration Time Option in OEM Softener System Setup Step 9S. Press NEXT to go to Step 5I. Press REGEN to return to previous step.

When Step 6CS is set to a value of two to four, additional regeneration time settings will be viewed. These displays are used to set additional times of day where a regeneration cycle may be initiated by the control as needed. When this feature is active a number (#1 - #4) will be added to the upper right corner of this display to indicate which of the additional regeneration time settings is currently being viewed.



#### STEP 5I

**STEP 5I** – Next Regeneration Time (minutes): Set the minutes of day for regeneration using ▲ or ▼ buttons. This display will not be shown if “IMMEDIATE” is selected in Set Regeneration Time Option in OEM Softener System Setup Step 9S. Press NEXT to go to Step 6I. Press REGEN to return to previous step. When this feature is active a number (#1 - #4) will be added to the upper right corner of this display to indicate which of the additional regeneration time settings is currently being viewed.



### RETURN TO NORMAL MODE

### Contact Screens

From Step 4I, press and hold both the CLOCK and ▲ button to change phone number and banner text.



**Phone Number** - Set phone number using the ▲ or ▼ arrow. Press NEXT to forward to the next digit. Press REGEN to return to previous digit.

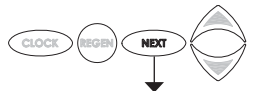

**Banner Text** - Set the banner text up to a maximum of 44 characters. Use the ▲ or ▼ to select letters of the alphabet or a number in the banner text. Press NEXT to forward to the next character or to exit the Installer Display Settings.





### User Display Settings

#### General Operation

When the system is operating, one of six displays may be shown. Pressing NEXT will alternate between the displays. One of the displays is always the current time of day. The second display is one of the following: days remaining or volume remaining. Days remaining is the number of days left before the system goes through a regeneration cycle. Capacity remaining is the gallons that will be treated before the system goes through a regeneration cycle. Pressing the ▼ button while in the Capacity Remaining or Days Remaining displays will decrease the capacity remaining in 10 gallon increments or the Days Remaining in 1 day increments, and will also increase the volume used impacting the recorded values in Diagnostics Steps 3D, 4D and 5D and Valve History, Step 4VH.

The third display shows the current treated water flow rate through the system. The fourth display will display contact screen information, if it was edited. The fifth display will show either dP or hold if the dP switch is closed. The sixth display indicates the user should call for service. The service display will not appear if OFF is selected in Step 12S of OEM Softener System Setup. To clear the Service Call reminder, press the ▲ and ▼ buttons simultaneously while the number and banner text screen is displayed.

If the system has called for a regeneration that will occur at the preset time of regeneration, the words REGEN TODAY will alternate with the header on the display.

If a water meter is installed, the water drop flashes on the display when water is being treated (i.e. water is flowing through the system).

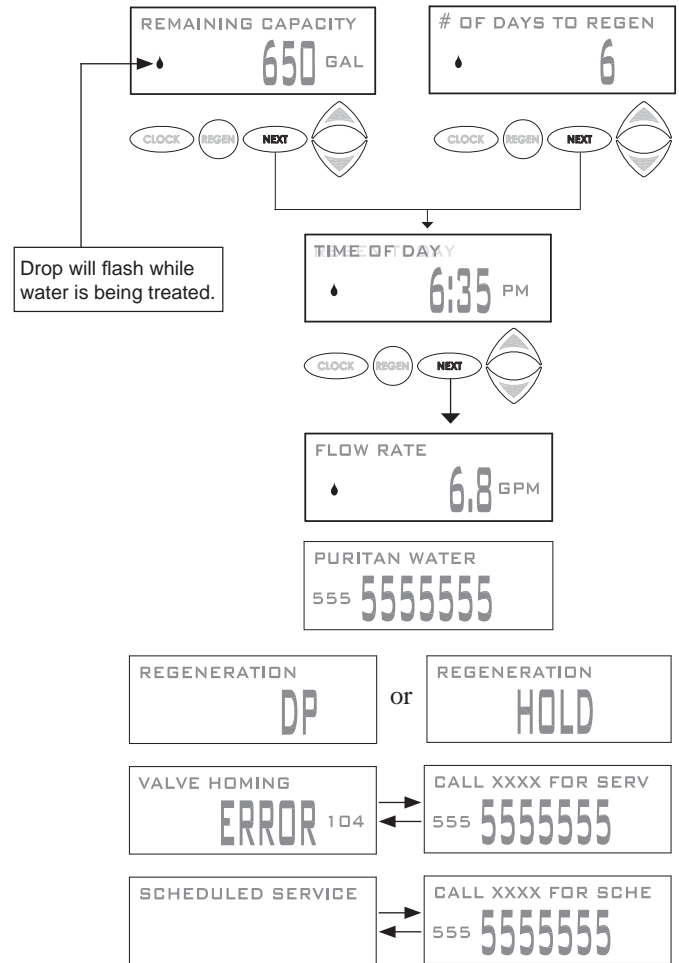

#### Regeneration Mode

Typically a system is set to regenerate at a time of low water usage. An example of a time with low water usage is when a household is asleep. If there is a demand for water when the system is regenerating, untreated water will be used.

When the system begins to regenerate, the display will change to include information about the step of the regeneration process and the time remaining for that step to be completed. The current cycle display will alternate with the regen time remaining screen. The system runs through the steps automatically and will reset itself to provide treated water when the regeneration has been completed.

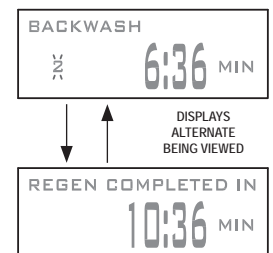

#### Manual Regeneration

Sometimes there is a need to regenerate the system sooner than when the system calls for it, usually referred to as manual regeneration. There may be a period of heavy water usage because of guests or a heavy laundry day.

To initiate a manual regeneration at the preset delayed regeneration time, when the regeneration time option is set to “DELAYED REGEN” or “DELAY + IMMEDIATE”, press and release “REGEN”. The words “REGEN TODAY” will periodically be shown on the display to indicate that the system will regenerate at the preset delayed regeneration time. If you pressed the “REGEN” button in error, pressing the button again will cancel the request. Note: If the regeneration time option is set to “IMMEDIATE” there is no set delayed regeneration time so “REGEN TODAY” will not activate if “REGEN” button is pressed.

To initiate a manual regeneration immediately, press and hold the “REGEN” button for three seconds. The system will begin to regenerate immediately. The request cannot be cancelled.

Note: For softeners, if brine tank does not contain salt, fill with salt and wait at least two hours before regenerating.

**Set Time of Day**

The user can also set the time of day. Time of day should only need to be set if the battery has been depleted because of extended power outages or when daylight saving time begins or ends. If an extended power outage occurs, the time of day will flash on and off which indicates the time of day should be reset. The non rechargeable battery should also be replaced.

**STEP 1U**

**STEP 1U** – Press CLOCK.



**STEP 2U**

**STEP 2U** - Current Time (hour): Set the hour of the day using ▼ or ▲ buttons. AM/PM toggles after 12. Press NEXT to go to Step 3U.

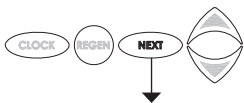

**STEP 3U**

**STEP 3U** - Current Time (minutes): Set the minutes of the day using ▼ or ▲ buttons. Press NEXT to exit Set Time of Day. Press REGEN to return to previous step.

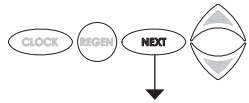

**RETURN TO NORMAL MODE**



REGEN PENDING will be displayed in Alternator Systems whenever a unit is waiting to initiate the first cycle step of regeneration.



STAND BY will be displayed in Alternator Systems when a valve is in Standby state.



DELAYED RINSE+ FILL PENDING will be displayed whenever a zero-capacity tank has transferred to an off-line state and is currently waiting to initiate the second portion of a regeneration cycle. Viewed only when Delayed Rinse and Fill is set to ON.

**Power Loss**

If the power goes out the system will keep time until the battery is depleted. If an extended power outage occurs, the time of day will flash on and off which indicates the time of day should be reset and the non rechargeable battery replaced. The system will remember the rest.

**Error Message**

If the word "ERROR" and a number are displayed contact the OEM for help. This indicates that the valve was not able to function properly. If the number and banner text display has been edited, the two displays will alternate.



## Diagnostics

**STEP 1D**

**STEP 1D** – Press ▲ and ▼ simultaneously for three seconds. If screen in step 2D does not appear in 5 seconds the lock on the valve is activated. To unlock press ▼, NEXT, ▲, and CLOCK in sequence, then press ▲ and ▼ simultaneously for 3 seconds.

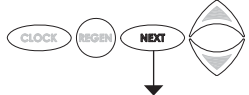
**STEP 2D**

**STEP 2D** – Days, since last regeneration: This display shows the days since the last regeneration occurred. Press NEXT to go to Step 3D. Press REGEN to exit Diagnostics.

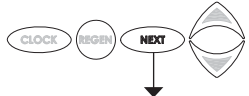
**STEP 3D**

**STEP 3D** – Volume, since last regeneration: This display shows the volume of water that has been treated since the last regeneration. This display will equal zero if a water meter is not installed. Press NEXT to go to Step 4D. Press REGEN to return to previous step.

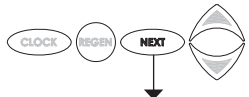
**STEP 4D**

**STEP 4D** – Reserve History Volume used for last 7 days: If the valve is set up as a softener, a meter is installed and Set Volume Capacity is set to “Auto,” this display shows 0 day (for today) and the reserve capacity. Pressing the ▲ button will show day 1 (which would be yesterday) and the reserve capacity used. Pressing the ▲ button again will show day 2 (the day before yesterday) and the reserve capacity. Keep pressing the ▲ button to show the capacity for days 3, 4, 5 and 6. The ▼ button can be pressed to move backwards in the day series. This screen is not displayed if filter, time clock, meter immediate, volume override or alternator regeneration is selected. Press NEXT at any time to go to Step 5D. Press REGEN to return to previous step.

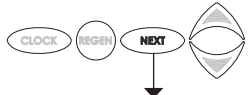
**STEP 5D**

**STEP 5D** - Volume, 63-day usage history: This display shows day 0 (for today), day 1 (for yesterday), etc., and the volume of water treated that day. Press the ▲ button to show the volume of water treated for the last 63 days. If a regeneration occurred on the day the letter “R” will also be displayed. This display will show dashes if a water meter is not installed. Press NEXT at any time to go to Step 6D. Press REGEN to return to previous step.

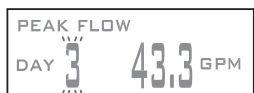
**STEP 6D**

**STEP 6D** – Flow rate, maximum last seven days: Use the ▲ or ▼ to display the maximum flow rate in gallons per minute that occurred in each of the last seven days. This display will equal zero if a water meter is not installed. Press NEXT to exit Diagnostics. Press REGEN to return to previous step.

**RETURN TO NORMAL MODE**

When desired, all information in Diagnostics, the Program and User Settings may be reset to defaults when the valve is installed in a new location. To reset, press NEXT and ▼ buttons simultaneously to go to the Softening/Filtering Type screen. Press ▲ and ▼ simultaneously to reset Diagnostics to zero and the Program and User Settings to defaults. The time will be reset to 12:00 P.M.

Valve History

**STEP 1VH**

**STEP 1VH** – Press ▲ and ▼ simultaneously for three seconds and release. Then press ▲ and ▼ simultaneously and release. If screen in step 2VH does not appear in 5 seconds the lock on the valve is activated. To unlock press ▼, NEXT, ▲, and CLOCK in sequence, then press ▲ and ▼ simultaneously for 3 seconds and release. Then press ▲ and ▼ simultaneously and release.

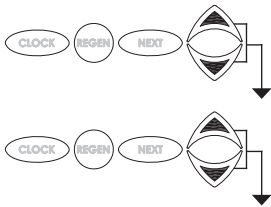

**STEP 2VH**

**STEP 2VH<sup>4</sup>** – Days, total since start-up: This display shows the total days since startup. Press NEXT to go to Step 3VH. Press REGEN to return to previous step.

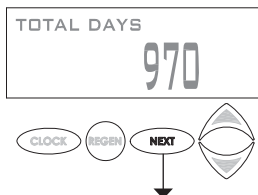

**STEP 3VH**

**STEP 3VH** – Regenerations, total number since start-up: This display shows the total number of regenerations that have occurred since startup. Press NEXT to go to Step 4VH. Press REGEN to return to previous step.

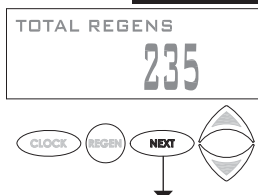

**STEP 4VH**

**STEP 4VH** – Volume, total used since start-up: This display shows the total gallons treated since startup. This display will equal zero if a water meter is not installed. Press NEXT to go to Step 5VH. Press REGEN to return to previous step.

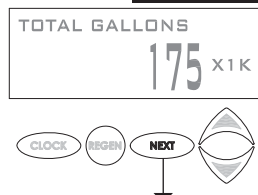

**STEP 5VH**

**STEP 5VH** – Flow rate, Total Peak Flow: This display shows the maximum flow rate since startup. Press NEXT to go to Step 6VH. Press REGEN to return to the previous step.

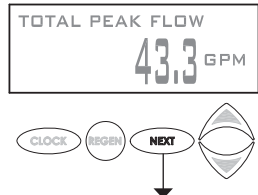

**STEP 6VH**

**STEP 6VH** – Total Errors: This displays the total number of errors detected since startup. Press NEXT to go to Step 7VH. Press REGEN to return to the previous step.

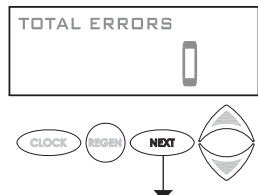

**STEP 7VH**

**STEP 7VH** – Log of the last 10 Error Codes generated by the control. Press the ▲ or ▼ button to view each error recorded. Press NEXT to exit Valve History. Press REGEN to return to the previous step.

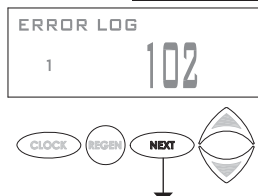

**RETURN TO NORMAL MODE**

<sup>4</sup> Values in steps 2VH through 7VH cannot be reset.





