



Clean Water Made Easy

[www.cleanwaterstore.com](http://www.cleanwaterstore.com)

## Fleck 2510 Greensand Installation & Start-Up Guide

Thank you for purchasing a Clean Water System! With proper installation and a little routine maintenance your system will be providing filtered water for many years.

Your new system comes with a printed Fleck Service manual, which along with this start-up guide will help guide you in the installation and start-up of your new system. The Fleck service manual covers other types of systems as well such as water softeners and filters, so there may be information in your Fleck service manual that does not pertain to your system. Please review this start-up guide entirely before beginning to install your system and follow the steps outlined for best results.



### Questions?

Call us toll-free: 1-888-600-5426 or 1-831-462-8500

Email us: [support@cleanwaterstore.com](mailto:support@cleanwaterstore.com)

See more information on our website: [www.cleanwaterstore.com/resources](http://www.cleanwaterstore.com/resources)



# Clean Water Made Easy

[www.cleanwaterstore.com](http://www.cleanwaterstore.com)

## Table of Contents

Packing List .....	2
Pre-Installation .....	3
Best Practices for Piping & Drain Installation .....	3
How Your Greensand Filter Works.....	4
Installation Instructions .....	7
Attaching the Perm Tubing to the Perm Solution Tank .....	10
Maintaining Your Greensand 2510 Filter System .....	12
Troubleshooting the Fleck 2510 Greensand Filter .....	14
More Troubleshooting Tips .....	15
Potassium Permanganate Not Being Sucked In During Regeneration .....	15
System Not Backwashing Adequately .....	16
Potassium Permanganate Tank with Float .....	16
Permanganate Tank Not Filling with Permanganate Solution .....	16
What To Do If Your Filter Tank Does Not Sit Level On the Floor.....	17
Using a Chlorine Feed to Regenerate the Greensand Media .....	18
Understanding Free vs. Total Chlorine .....	18
Fig 1: Typical installation showing chlorine pump, contact tank, Greensand filter and optional carbon filter .....	19
Setting Up a Chlorine Feed Pump .....	20
Starting Up Your New Greensand Plus Filter with Chlorine Feed .....	20

---

# Fleck 2510 Greensand Installation & Startup Guide

---

## Packing List

### Model Size: 1.0 Cubic Foot Greensand:

Quantity	Description
1	Fleck 2510 backwash control valve & bypass valve
1	Pipe connector kit (either 1" or ¾")
1	10" x 44" filter tank with distributor tube
1	Media funnel
1	12 lbs Gravel
2	½ cubic foot boxes of Greensand filter media
1	Potassium permanganate black solution tank

### Model Size: 1.5 Cubic Foot Greensand:

Quantity	Description
1	Fleck 2510 backwash control valve & bypass valve
1	Pipe connector kit (either 1" or ¾")
1	10" x 54" filter tank with distributor tube
1	Media funnel
1	16 lbs Gravel
3	½ cubic foot boxes of Greensand filter media
1	Potassium permanganate black solution tank

### Model Size: 2.0 Cubic Foot Greensand:

Quantity	Description
1	Fleck 2510 backwash control valve & bypass valve 1
1	Pipe connector kit (either 1" or ¾")
1	12" x 52" filter tank with distributor tube
1	Media funnel
1	20 lbs Gravel
4	½ cubic foot boxes of Greensand filter media
1	Potassium permanganate black solution tank

### Model Size: 2.5 Cubic Foot Greensand:

Quantity	Description
1	Fleck 2510 backwash control valve & bypass valve 1
1	Pipe connector kit (either 1" or ¾")
1	13" x 54" filter tank with distributor tube
1	Media funnel
1	35 lbs Gravel
5	½ cubic foot boxes of Greensand filter media
1	Potassium permanganate black solution tank

## Pre-Installation

1. Review your packing list and make sure you have received all the parts before beginning installation.
2. If you are going to be turning off the water to the house and you have an electric water heater, shut off the power to the water heater before beginning installation in case water heater is accidentally drained.
3. Pick a suitable location for your filter system on a dry level spot where it won't be exposed to freezing temperatures. A minimum of 20 PSI is required. Maximum pressure is 90 PSI.
4. Get all of your plumbing parts together before beginning installation. Installation typically takes 3 to 5 hours. However after installation the Greensand Filter must be allowed to run through a complete backwash and rinse cycle (also called 'regeneration'). You don't have to be present for this first backwash necessarily, but it does take 90 minutes.
5. After the system is installed and running, your water may be discolored, or full of sediment or rust, particularly if this is older piping that has been exposed to iron or manganese for some time. Typically this clears up over a day or two, but can persist for weeks if the pipe is old galvanized iron pipe that is corroded.

## Best Practices for Piping & Drain Installation

1. See typical installation (see Fig 1). The greensand filter is installed after the pressure tank.
2. Make sure to connect the inlet pipe to the Fleck 2510 inlet and the outlet to the outlet (see Fig 2). As you face the Fleck 2510 control from the front, the water enters on the right and exits on the left. From the back (see Fig 2) the water enters on the left. The inlet and outlet are attached to the bypass valve which is marked with arrows as well.
3. Make sure there is a working gate or ball valve before the Fleck 2510 Greensand filter and also one after as shown in the diagram. The pressure gauges are optional and not necessary but a hose bib (which is a faucet that you can attach a garden hose to) is strongly recommended after the Greensand Filter before the second ball valve. This makes it easy to rinse your new iron filter on start-up and gives you a place to test the water before it enters your household plumbing.
4. If you will be using copper piping, do not sweat the copper pipe directly on to the Fleck 2510 control valve. Avoid heating up the Fleck 2510 control valve plastic with the torch.

5. You do not need unions to install your Fleck 2510 control. If you need to remove it, the Fleck 2510 has quick-release couplings that make it easy to put the Greensand Filter on by-pass and remove the filter system from the piping.
6. The drain line tubing (not supplied) is connected to a drain from the drain outlet using flexible ½" ID tubing. Note that the drain can run up above the Fleck 2510 control and into a drain, it does not have to drain down, as the filter backwashes under line pressure from your well pump. Most plumbing codes require an air-gap connection, so that if your sewer or septic tank backs up, it cannot cross connect with the drain tubing.

## How Your Greensand Filter Works

See Fig 1. In greensand iron filter, the water enters the top of the tank and flows down through the media and up the distributor tube. Iron and manganese in the water turns to an oxidized particle upon contact with the media and is trapped in the media. During backwash, the water flow is reversed and water flows down the distributor tube and up through the media, lifting and expanding the greensand filter media, and removing all the iron and rust trapped in the filter. After the backwash stage, potassium permanganate solution is automatically drawn in from the potassium permanganate solution tank and slowly rinses through the greensand filter for 1 hour, and then the greensand media is thoroughly rinsed-to-drain. This entire automatic process, called 'regeneration' takes about 90 minutes. Typically the greensand filter is set to regenerate every 3 to 7 days, during the middle of the night when no water is being used.

Fig 1

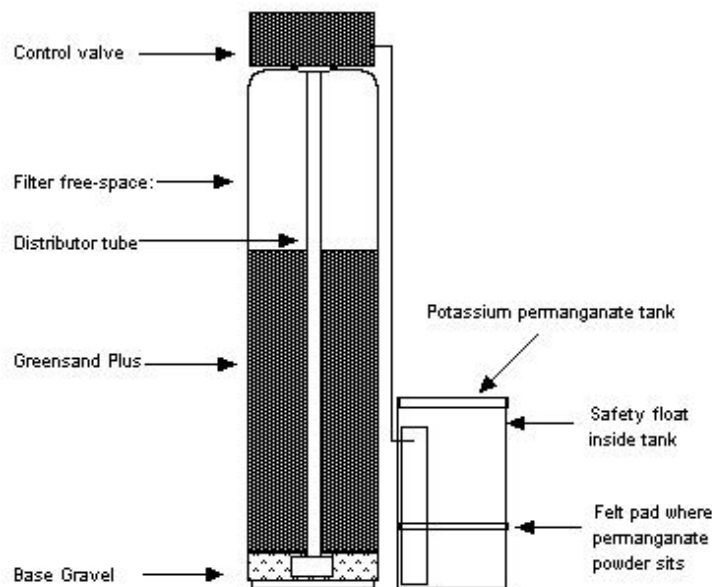
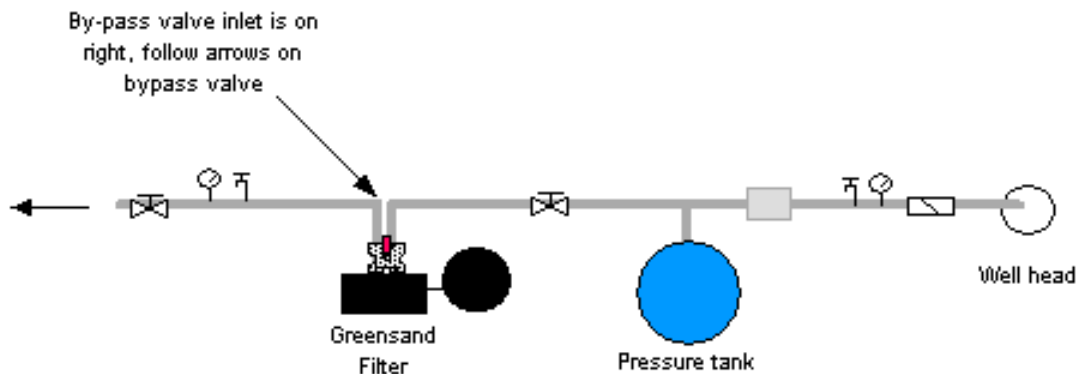
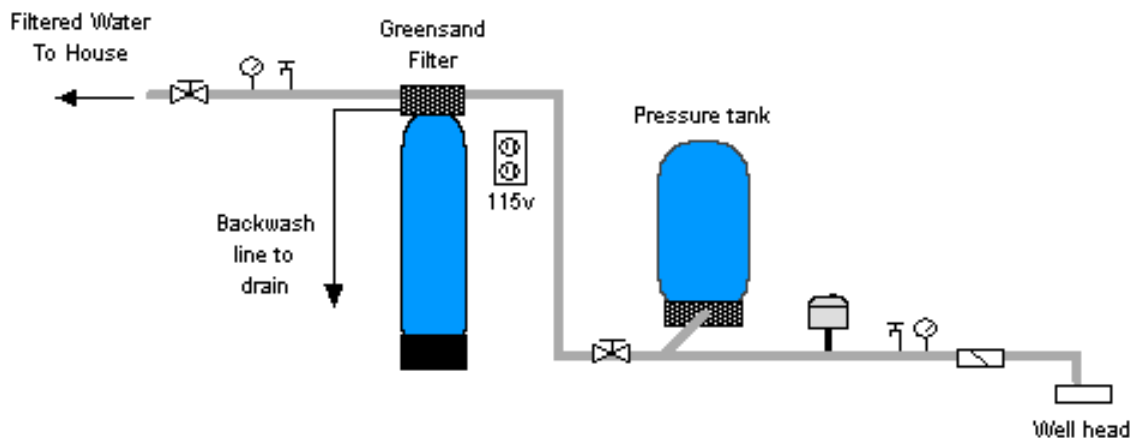

Fig 2 - Typical Greensand Fleck 2510 piping installation with ball valve and hose bib after the filter



- Key**
- |  |                |  |                    |
|--|----------------|--|--------------------|
|  | Water piping   |  | Hose bib           |
|  | Check valve    |  | Pressure switch    |
|  | Pressure gauge |  | Gate or ball valve |

Fig 3: Fleck 2510 from the rear showing the inlet and outlet end-connector fittings 1" or 1-1/4" NPT in Noryl plastic. Brass end-connectors are also available for connecting to copper tubing.



Fig 4: Fleck 2510 Side View



## Installation Instructions

1. Unscrew by hand the entire Fleck 2510 control valve from top of tank if it was shipped screwed on. Place distributor tube in tank if not already inside tank. If not already done, make sure blue cap is on top of distributor tube, or wrap the top of distributor tube with electrical or duct tape. The idea is we do not want gravel or media to go down the distributor tube.

**Plug or tape top of distributor tube when adding media to prevent media from entering. Remove when finished.**



2. Add filter gravel supplied first, using the funnel sent with the greensand filter.
3. Next add greensand media. Tank will be approximately 2/3 to the 3/4 full.
4. Remove cap or tape from top of distributor tube. Be careful not to pull up distributor tube when removing cap or tape.
5. Attach plastic top screen to the under-side of the Fleck 2510 control valve. It is a funnel-shaped plastic screen that snaps on to the control valve and prevents resin from being backwashed out to drain during the regeneration cycles.

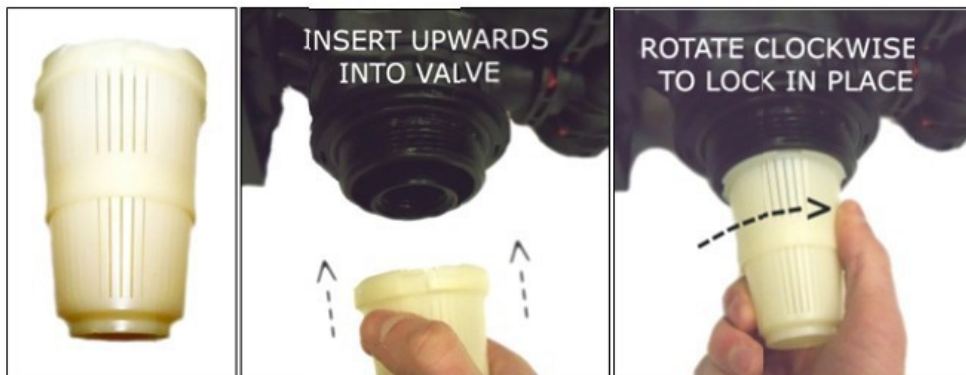



## Fleck 2510 Greensand Installation & Startup Guide

- NOTE Regarding Teflon tape and pipe sealants: It is OK to use Teflon tape and pipe sealant on the water pipe connector threads, where you attach your pipes or plumbing to the Fleck 2510. DO NOT USE any Teflon tape or pipe joint compound on the tank itself or on the threads where the Fleck 2510 threads into the tank.
- Install the Fleck 2510 backwash control-timer valve on to the top of the filter tank by hand, do not over-tighten. Tighten with hands, there is no need for a pipe wrench or other wrench.
- See the bypass image below. Note that the detached threaded pieces are the pipe connectors and the other end is what gets attached to the control valve. The nuts and steel brackets are what join the pipe connectors to the bypass. Do not remove this bracket. Just turn knobs (1). Fleck 2510 is usually shipped in by-pass position. Leave in by-pass position for now.

### Fleck 2510 Bypass (1) & Pipe Connectors (2)

BY-PASS VALVE - Shown in By-Pass Mode

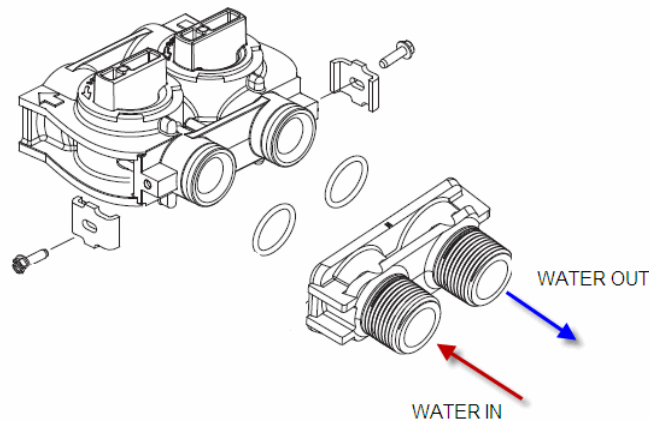

Service Mode



Bypass Mode

---

## Fleck 2510 Greensand Installation & Startup Guide

---

9. Lubricate the by-pass valve o-rings only on the pipe connectors with some vegetable oil or silicone grease and connect the bypass assembly to the Fleck 2510 control by sliding the bypass valve firmly into the body of the Fleck 2510. Once bypass is in far enough, you will be able to easily tighten the screws onto the steel brackets. **DO NOT USE OIL OR PETROLEUM GREASE ON ANY PART OF THE FLECK 2510 CONTROL VALVE.** O-rings are OK to lubricate but not the main tank threads.
10. Make sure the by-pass valve is in the bypass position when starting the installation. Follow the IN and OUT arrows on the bypass valve and control valve for proper connection of in and out water piping. Leave in the BY-PASS position for now.
11. Now install your water pipes to the Fleck 2510 bypass end connectors. Our preferred method is to wrap the pipe threads with 2 or 3 wraps of Teflon tape, then apply a thin coating of white non-hardening Teflon joint compound paste (available at all hardware stores) before attaching the pipe fittings. Make sure inlet is installed to the "In" pipe connector on the bypass valve and outlet is on the "Out" connector. **Note:** Arrows on bypass valve should be visible from the top of the bypass valve.
12. Connect some flexible tubing from the drain connection on the Fleck 2510 control valve to a suitable drain such as a septic tank or drain to a sewer. It is OK to run the drain line up and over the Fleck 2510 Greensand filter up to 4 feet above the top of the tank. If the drain line will be more than 20 feet, and especially if your system is a 2.0 or 2.5 cubic foot size, use larger diameter tubing such as  $\frac{3}{4}$ " or 1". Note that it is desirable to be able to run the drain line into a bucket in order to test the backwash flow rate in the future. This is why hard piping the drain line is discouraged, however, if you do use hard PVC piping for the drain line, and you are able to remove the hard PVC drain piping and attach flexible tubing should you ever desire for testing purposes, it is OK to use rigid PVC pipe for the drain. Make sure the drain tubing is firmly clamped to the barbed fitting with a hose clamp to prevent leaks.
13. For the 2.5 cubic foot and larger systems only: use external drain backwash flow control. If you have a 1.0 or 1.5 cubic foot or 2.0 cubic foot size, the flow control is internal and there is no external flow control. Wrap some Teflon tape on the black drain fitting, and screw on the flow control.

### Stainless Steel Backwash Drain Flow Control (2.5 Cubic Foot Systems Only)



- Next, connect the solution tank to the Fleck 2510 control valve with the black tubing, provided with the POT-PERM tank.

### Attaching the Perm Tubing to the Perm Solution Tank & the Fleck 2510 Brine Valve



*Brass Brine Injector Nut with White Compression Ring*

- Begin by sliding the brass brine injector nut on to the brine tubing by putting the tubing through the non-threaded side of the nut. Next, slide the white compression ring on to the tubing with the wider diameter going on first. Slide this in to the brine injector nut and place the brine tubing into the brine valve. Finally, push the brine injector nut, which now has the compression ring inside of it, on to the threading of the brine valve and rotate the nut clockwise, screwing it on to the brine valve. Tighten it down to finger tightness. The tubing should be firmly attached and not slide out if pulled on.

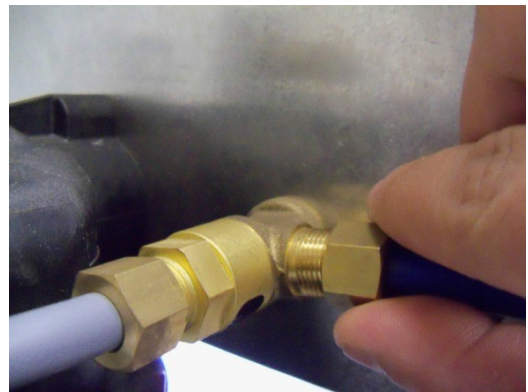

- To connect the brine line to the perm solution tank, slide the plastic perm solution tank nut on the brine tubing through the non-threaded side of the nut. Next, slide the black (or clear) compression ring with the narrower diameter going on first. Then slide the taller, white compression ring onto the tubing with the wider diameter going on first. The two compression fittings should lay flush against each other on the tubing. Slide them into the perm solution tank nut and place the tubing into the tank valve. Push the solution tank nut with the compression rings inside, onto the threading of the tank valve and rotate the nut clockwise, screwing it onto the tank valve. Tighten it down to finger tightness. The tubing should be firmly attached and not slide out if pulled on.



17. Add enough clean water to the pot perm solution tank to bring water level about 1" above the felt pad. Add one 2 or 5-lb jug of potassium permanganate granules to the potassium perm tank by pouring it directly on top of the white felt pad. Do not pour permanganate down the white plastic brine well where the black line is attached.
18. See the over-flow barbed fitting on the side of the perm tank. You do not have to connect this to a drain. If the safety float were to malfunction, there is a small chance that pot perm solution will drip out of this fitting. If this would cause a big mess where you have installed the greensand filter, hook some tubing to this and run to a bucket, floor pan or floor drain. Normally no pot perm solution will leak out of this fitting.
19. Now you are ready to turn on the water to the system. Turn on the water and leave on bypass and check for leaks. Leave the ball valve after the greensand filter closed, so water is still off to the house, but connect a garden hose and open up the hose bib after the greensand filter and allow the water to run. This will help to clear out any foreign material that may be in the pipes from the piping installation. If you do not have a valve installed after the greensand filter and you do not have a hose bib, you will need to turn the water on inside the house to let the water run. Use a bathtub or laundry sink or other fixture that does not have an aerator screen.
20. Leave the water running out of the garden hose at a slow rate. Now you can turn the bypass valve to the service position. First open the Inlet Side of the bypass valve. Second slowly open the Outlet Side of the bypass until it is in the full service position. The Fleck 2510 bypass valve knobs are a little stiff, so you can use a screw driver placed in the holes to turn the knobs. Make sure you are turning the bypass valve knobs in the correct direction which is clockwise as you look down on the bypass valve knobs.
21. Now turn on the garden hose to full force and let the water until it turns relatively clear. The water may be dark or black at first.

22. Open the timer cover and swing open the timer assembly to view the program wheel. 1 pin on the program wheel equates 2 minutes. The program wheel has come preset and does not need to be changed.

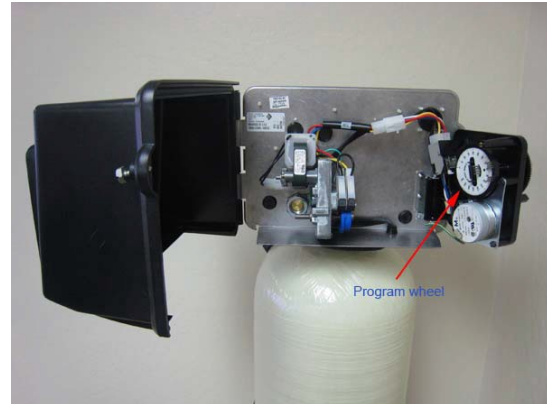

23. Before putting the filter into general use, the Greensand-Plus filter media needs to be backwashed and regenerated thoroughly with potassium permanganate.
24. Turn the manual regeneration control knob on the front of the timer assembly clockwise a few degrees until you hear and see the control valve go into the first position, or backwash position. By having the timer assembly open, you can see the program wheel on the back turn when the knob on the front is turned.
25. Allow for one full regeneration cycle (which includes a backwash, permanganate rinse and rapid rinse) to complete. This should take 90 minutes.
26. After the regeneration cycle is complete, turn the regeneration knob and allow the filter to go through an additional regeneration. Now that it has been able to complete the cycle, the permanganate tank will have enough water to cover the felt pad by one or two inches.
27. The frequency of the backwash is controlled by the 12-day skipper wheel on the front of the timer assembly. Typically, these filters backwash every 4 days for high levels of iron. If the pin is sticking out on the skipper wheel, then the filter will backwash on the night selected.

### Maintaining Your Greensand 2510 Filter System

#### Adding Potassium Permanganate:

Add one 5-lb jug of potassium permanganate every 3 - 4 months. Check the potassium permanganate solution tank and when you see the mound of potassium permanganate disappear after a few months, just add another 5-lb jug. In some cases, you won't see the mound, you might just see solution after a couple of weeks. This is OK, you still only need to add the potassium permanganate every 3 months in most cases. If you have it set to regenerate (backwash cycles) every 1 - 3 days, you might need to add it more frequently, perhaps every 2 months.

## Clean the Injector

Once a year, clean the permanganate solution tank and the brine injector.

1. Shut off water to filter or put filter on bypass.
2. Release water pressure by turning the center knob on the timer assembly by a few degrees clockwise.
3. Unplug the control valve from the electrical outlet.
4. Unscrew the bolts (#18 in the diagram) and using a small screwdriver, remove nozzle and throat (#15 and #14), unscrewing counter-clockwise. You may need to use a paper clip or other piece of wire to remove the lower nozzle once it is unscrewed.
5. Replace and/or clean parts #13, 14 and 15 in muriatic acid or vinegar.
6. Put the system back in service and plug in the control valve. Make sure the timer assembly is advanced so the piston is in the service position. If you are not sure, wait two hours until the timer assembly does this automatically.
7. Next clean the potassium perm tank by removing the felt pad and cleaning in muriatic acid, citric acid or vinegar, or better yet just replacing the felt pad if you want. Clean the float and rinse the pot perm tank out. It's better to use rubber gloves when you are doing this to avoid the possibility of staining your hands with potassium permanganate. If your hands do become stained you can clean them with vinegar or lemon juice.

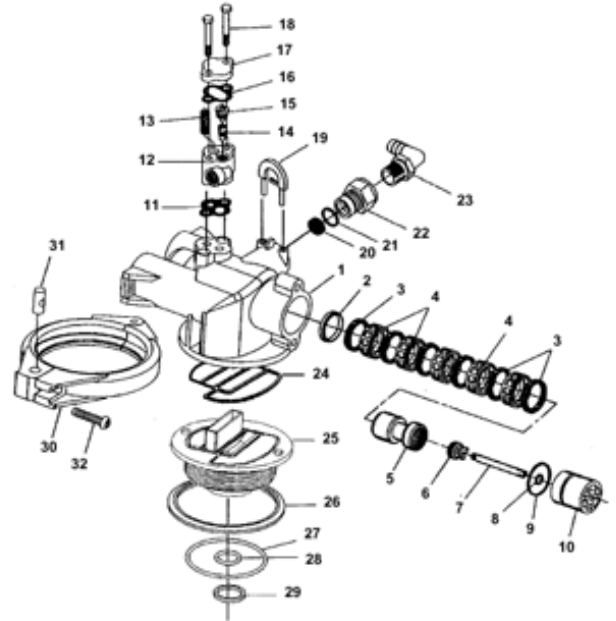



## Troubleshooting the Fleck 2510 Greensand Filter

PROBLEM/SYMPTOM	POSSIBLE CAUSE	SOLUTION
<p>Iron or manganese or sulfur odor in treated water after Greensand Filter</p>	<p>No permanganate in solution tank</p> <p>Not backwashing often enough</p> <p>Water being used when Greensand Filter is in a regeneration.</p> <p>Permanganate solution is not being sucked in during the regeneration brine cycle.</p> <p>Greensand media exhausted</p>	<p>Add permanganate powder to tank and regenerate greensand filter</p> <p>Set to backwash more frequently. Backwash twice in one day and re-check water.</p> <p>If any water is used during the 90 minute regeneration cycle, untreated water will enter household piping. Set time Greensand Filter regenerates to a time when no one will be using the water.</p> <p>Clean brine injector</p> <p>Clean potassium permanganate tank</p> <p>Replace permanganate support pad in permanganate tank</p> <p>Inadequate backwash flow. Make sure there that Greensand Filter is backwashing at the correct backwash flow rate (5 to 10 gallons per minute depending on size of filter).</p> <p>Low water pressure. Increase water pressure to unit by adjusting well pump pressure switch, or replacing well pump.</p> <p>Replace Greensand media with new Greensand.</p>
<p>Strong sulfur odor before and after Greensand filter</p>	<p>High levels of hydrogen sulfide gas in well water</p>	<p>In some cases, the greensand filter may need a chlorine feed (or ozone, oxygen or other oxidizer) prior to the filter. Make sure Greensand filter is working correctly, and try regenerating it once or twice a day for one week. If odor persists, replace Greensand media or add a chlorinator ahead of the Greensand Filter.</p>
<p>Pink water (permanganate) in household water</p>	<p>Inadequate backwash of Greensand Filter</p>	<p>Make sure Greensand Filter has adequate backwash at a good pressure and flow rate</p>

	Clogged brine injector Inadequate rinse time Too much permanganate	Clean or replace injector Set rinse cycle to longer time Lower float so that level of permanganate is lower in permanganate solution tank.
Potassium permanganate tank over-filling or over-flowing	Clogged brine injector	Clean or replace injector

## More Troubleshooting Tips

### Potassium Permanganate Not Being Sucked In During Regeneration

Most problems occur when the Fleck 2510 is not drawing in the potassium permanganate. Make sure the injector is drawing in the potassium permanganate:

1. Remove the permanganate solution tank tubing where it enters the Fleck 2510 control valve.
2. Turn the regeneration knob clockwise on the timer assembly until a backwash is started. After it is in a backwash cycle, turn the regeneration knob some more, and it will advance to the next cycle, which is the Brine Cycle, where it is supposed to suck in the permanganate solution.
3. If it is sucking strongly, check the potassium permanganate solution tank float inside the brine well and make sure there is no rubber bands around it, and that it is free of obstructions. In some cases it may need to be replaced or cleaned, if there is suction at the control valve, but no permanganate is being drawn in.
4. If there is NO suction at the control valve port where you removed the permanganate tubing, then the injector should be cleaned.
5. If the injector has been cleaned and there is still no suction check to make sure there is obstruction in the backwash line; that the backwash line does not go up and over the greensand filter more than several feet (which causes pressure loss and the injector not to work correctly); finally check to make sure there is enough pressure. If possible increase your water pressure to the iron filter from your well pump and see if a slightly increased pressure makes the injector work. We recommend a minimum 30 PSI but it does work better if there is 40 to 50 minimum PSI.



# Fleck 2510 Greensand Installation & Startup Guide

## System Not Backwashing Adequately

The other second main problem that may occur is if you do not have enough backwash flow rate to properly clean the greensand filter. You can verify the backwash flow rate by running the drain line into a bucket and timing it when the Fleck 2510 is in Cycle 1 or backwash. A 1.0 or 1.5 cubic foot system should have 5 gallons per minute and a 2.5 cubic foot system should have 10 gallons per minute of backwash.

## Potassium Permanganate Tank with Float

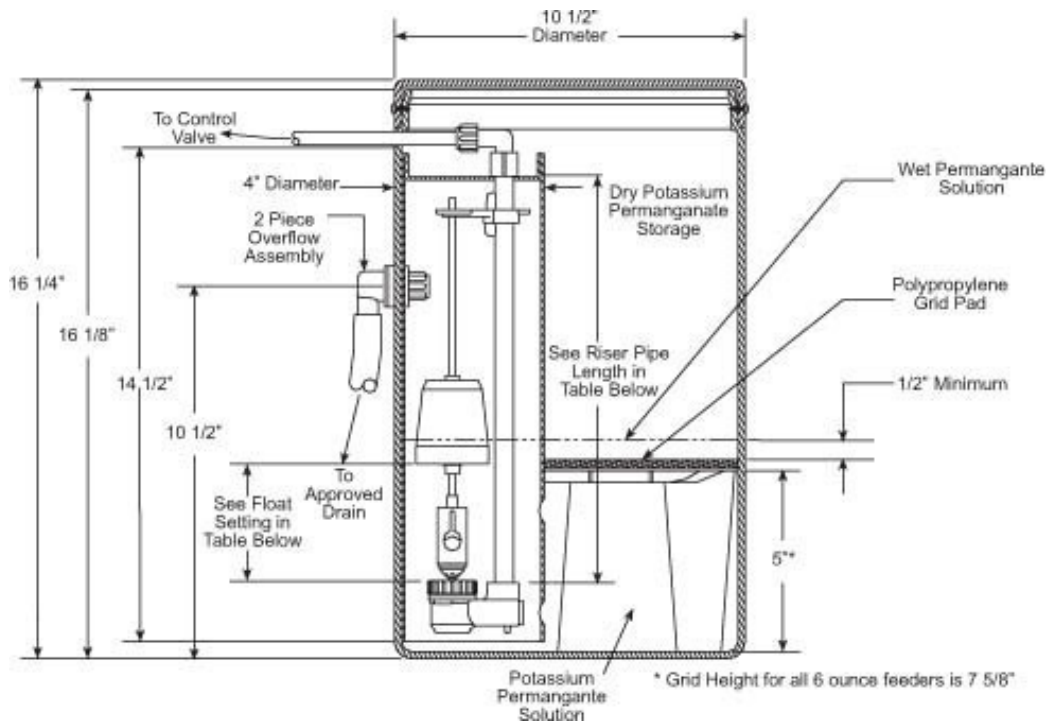

## Permanganate Tank Not Filling with Permanganate Solution

Potassium permanganate is a powder that is poured on top of the “grid pad” in the pot perm tank. During the brine fill cycle, water is added to the pot perm tank to make up the pot perm solution required for the next regeneration.

If your pot perm does not have ½” to 1” of solution above the grid pad, the first to check is to make sure it is filling the tank:

1. Disconnect the 3/8” black poly line at the pot perm tank or at the control valve.
2. Put the system into a regeneration cycle by turning the regeneration knob clockwise. You can advance to the Brine Fill cycle by turning the regeneration cycle further. Advance to the BF cycle.

---

## Fleck 2510 Greensand Installation & Startup Guide

---

3. If it IS filling, remove the safety float and make sure the air check ball is moving free and not stuck. A stuck float is often the cause of this problem and can be easily fixed. If the float is defective or older than 5 years, replace float.
4. If it is NOT filling during the Brine Fill (BF) cycle, then make sure there are enough minutes. It should be set for 12 minutes for standard size Clack pot perm tanks. If you have a larger commercial size tank, set for 20 minutes.
5. If it is still not filling, the brine valve may need to be cleaned. In the Fleck 2510 manual, in the diagram "Valve Assembly", disconnect the parts listed and clean them thoroughly.



### What To Do If Your Filter Tank Does Not Sit Level On the Floor

Your black filter tank base is not glued to the bottom of your tank. Occasionally tank bases will become crooked during shipment. If you find that that your tank does not sit level on the floor, you can easily adjust it by holding the empty tank and rapping it on a concrete or solid floor once or twice in order to level it.

### **Using a Chlorine Feed to Regenerate the Greensand Media**

However, in place of intermittent regeneration with potassium permanganate, the water can be chlorinated prior to the greensand filter in a process called 'continuous regeneration.

In order for the chlorine to work as a replacement for potassium permanganate there must be sufficient chlorine residual in the water and there must be a long enough contact time after the chlorine has been injected.

Fortunately this is easy to accomplish by installing a chlorinator and contact tank ahead of the iron filter.

For most residential and commercial applications we recommend using a liquid bleach injector that is a chlorinator that uses a small metering pump to pump in a bleach solution. This is because the chlorine dose is critical for successful operation. The chlorine dose can be easily controlled with a standard metering pump chlorinator whereas the does with a dry calcium pellet feeder is difficult to control.

The goal is to inject the chlorine automatically and have at least 5 minutes of contact time after the chlorine has been injected before the iron filter (see Fig 1). After the greensand filter you want to see a free-chlorine residual of 0.2 to 0.4 ppm.

### **Understanding Free-Chlorine vs Total Chlorine**

It is important to have a simple chlorine test kit where you can test the total chlorine and free chlorine. Chlorine combines with iron, manganese, hydrogen sulfide gas, bacteria and other contaminants in a process known as oxidation. As an example, say you were to add 2 ppm (same as saying 2 mg/L) of chlorine to some water and waited several minutes. You then measure the total-chlorine and find you have 2.0 ppm, but when you measure the free-chlorine, you find that the water has 0.5 ppm of free-chlorine. The difference between the 2.0 ppm of total chlorine and the 0.5 ppm of free-chlorine is 1.5 ppm. This is the "chlorine-demand." In other words your water has a chlorine-demand of 1.5 ppm. The 0.5 ppm of free-chlorine is that amount of chlorine that is left over that can still kill bacteria or be available.

By setting up your system correctly, you can have a small free-chlorine residual detected after the greensand filter. This insures that the greensand media will be properly and continually regenerated, which allows it work correctly and remove the iron and manganese. Proper chlorine residual and contact time also insures that the water is disinfected and prevents the spread of harmful bacteria and viruses if present, in addition to killing iron and sulfur bacteria which are commonly found in residential well water systems.

**Fig 1: Typical installation showing chlorine pump, contact tank, Greensand filter and optional carbon filter**

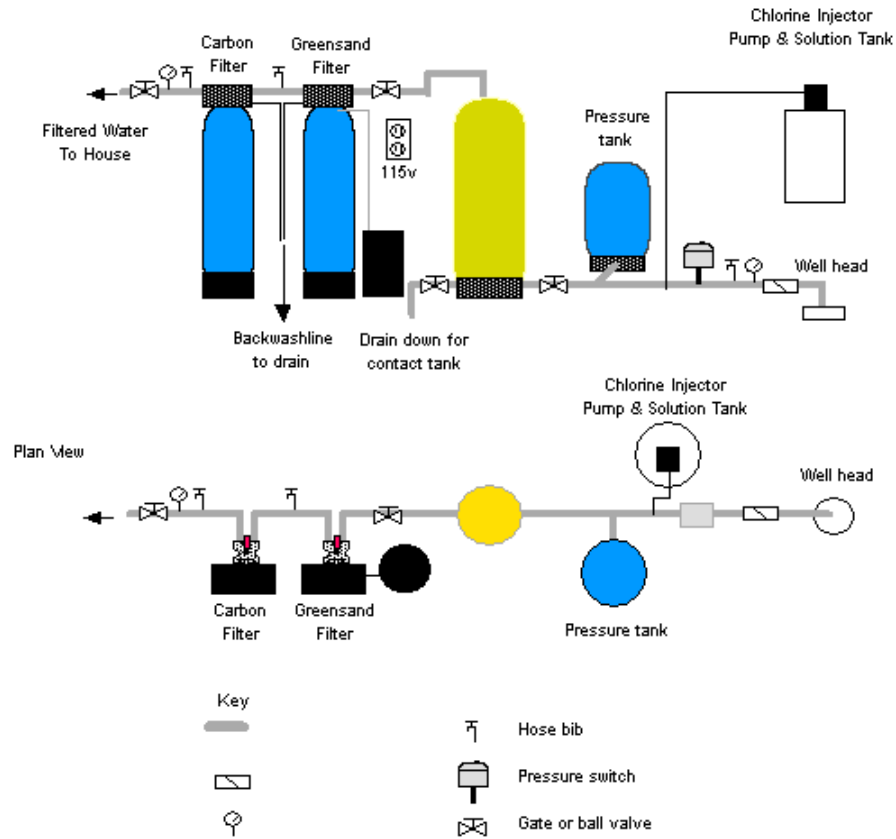

---

## *Fleck 2510 Greensand System Installation & Startup Guide*

---

### **Setting Up a Chlorine Feed Pump**

In Fig 1 the chlorine metering pump is 220v and is wired to the same 220v circuit as the well pump. When the well pump turns on, the chlorine metering pump also turns on and injects 1 to 2 ppm of chlorine for every 1 ppm of iron.

Chlorine Calculation and Setting the Metering Pump:

Assume 10 gallons per minute flow rate and 2 ppm of chlorine to be injected.

Assume a solution strength of 10,000 ppm, or 1 gallon of 10% to 12% pool chlorine for every 10 gallons of water.

$10 \text{ GPM} \times 2 \text{ PPM} \times 1440 \text{ (minutes in a day)} \text{ Divided by } 10,000 \text{ ppm} = 2.88 \text{ Gallons per Day}$

So assuming the above settings, you would need a metering pump that has an output of 2.8 gallons per day. For instance the Stenner 45MP2 has a maximum output of 3.0 gallons per day. So if your well has 10 gallons per minute, and you use a solution strength of 1 gallon of pool chlorine for every 10 gallons of water, and you set your 45MP2 to 90%, then you will be injecting approximately 2 ppm of chlorine into the water.

After you start up your chlorinator test the chlorine residual after the greensand filter, and before the carbon filter. You should have between 0.2 and 0.6 ppm of free-chlorine. If you have more or less, then you can adjust the Stenner pump, or adjust the solution strength.

TIP: start out with 1 or 2 gallons of solution in the solution tank, so you can easily change the solution strength if you need to.

### **Starting up Your New GreensandPlus Iron Filter with Chlorine Feed**

The Greensand media must be soaked in a chlorine bleach solution for several hours before being put into service. Follow the steps in the guide "Greensand Installation and Start-Up Guide" and backwash and rinse the media. Then turn up your chlorine injection pump to maximum setting, and allow it to pump in undiluted bleach so a higher concentration of bleach is pumped into the pipe. Allow this water to flow through the greensand filter, and then when the water has a high chlorine level inside the Greensand, turn it off and allow to sit for several hours. Backwash and rinse again before putting into service to clean out any excess chlorine.

After your greensand filter is online and in service make sure there is 0.2 to 0.8 ppm of free-chlorine residual in the water AFTER the greensand filter.