

## Table of Contents

<b>Introduction</b>	<b>3</b>
Welcome	3
Boss 302 history	4
Breaking-in your vehicle	5
<b>Boss® 302 Unique Features</b>	<b>6</b>
Unique features	6
<b>Driving your Boss® 302</b>	<b>9</b>
AdvanceTrac®	9
Driving through water	9
Ground clearance	9
Washing your vehicle	10
<b>Chassis</b>	<b>11</b>
<b>Tire Information</b>	<b>13</b>
Wheel lug nut torque	13
<b>Roadside Emergencies</b>	<b>18</b>
Wrecker towing	18
<b>Maintenance</b>	<b>21</b>
Battery	22
Engine oil	22
<b>Capacities and Specifications</b>	<b>24</b>
Refill capacities	24
Engine drivebelt	27

## **Table of Contents**

<b>Track Use Preparation</b>	<b>28</b>
<b>Warranty Coverage</b>	<b>31</b>

The information contained in this publication was correct at the time of going to print. In the interest of continuous development, we reserve the right to change specifications, design or equipment at any time without notice or obligation. No part of this publication may be reproduced, transmitted, stored in a retrieval system or translated into any language in any form by any means without our written permission. Errors and omissions excepted.

© Ford Motor Company 2011

2

## Introduction

### WELCOME

Congratulations on your decision to purchase the latest from Ford — the Boss® 302. If you've owned or leased a Ford product in the past, we're glad you're back. If this is your first Ford vehicle, welcome to the Ford family! We are confident that our dedication to performance, quality, craftsmanship and customer service will ensure many miles of exhilarating, safe and comfortable driving in your new Boss® 302.

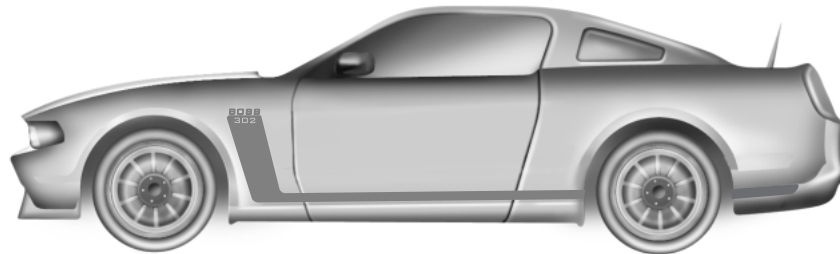

Your choice of a Ford product is an intelligent and informed one. Ford strives to build engaging vehicles that involve the driver in every aspect of the driving experience. Although performance is at the heart of every Ford vehicle, we go much further. Our goal is to deliver a comprehensive, complete vehicle, sweating the details such as the sound of the exhaust, the quality of the interior materials, and the functionality and the comfort of the seats, to ensure that the driver enjoys not only exceptional performance but an outstanding *driving environment* as well. In the Boss® 302, that philosophy is expressed by a sophisticated powertrain, outstanding chassis dynamics and significant interior and exterior enhancements.

This supplement complements your Mustang Owner's Manual and provides information specific to the Boss® 302. By referring to the pages listed in this supplement, you can identify those features, recommendations and specifications unique to your new vehicle. If there are any discrepancies between this supplement and the Mustang Owner's Manual, this supplement shall supersede the information found in the Mustang Owner's Manual.

## Introduction

### BOSS 302 HISTORY

The Ford Mustang isn't just a car – it's an American automotive icon. And of the more than 9 million Mustangs sold to date over the five different platform generations covering the past five decades, there is arguably one high-performance model that stands above the rest in both reverence and respect among enthusiasts, racers and collectors alike. That's the Boss® 302.

Many consider the 1969-70 model years to be the high-water mark of the so-called "Muscle Car era." Semon E. "Bunkie" Knudsen was hired as president in an effort to pump new blood into the Ford Motor Company product pipeline.

Bunkie set out to secure Ford corporate bragging rights once and for all with an all-new racing-inspired Mustang model. Knudsen wanted a Mustang race car to champion a hot, new Ford small-block V-8 that could power a competitive entry in the Trans Am road racing series. So he tagged designer Larry Shinoda with the task of designing what a production version of the new race car should look like.

Knudsen had ordered that his new road-racing Mustang not only be powerful, but also that it should be "absolutely the best-handling street car available on the American market." Shinoda came up with racy looks for the new Mustangs that he was designing for "the boss" – which was how he referred to Knudsen. Both the styling of "the Boss' car," and the name, stuck.

Enter the 1969 "Boss® 302" built to compete in the performance car arena. The Boss® 302 was built so that Ford could go out and win in Trans Am racing. Shinoda's design for the Boss® 302 included front and rear spoilers, racy side stripes, a matte-black hood and even rear window louvers – but it was performance that really helped sell the cars.

The Boss® 302 dazzled the enthusiast press, established a new level of interest in Ford performance, and became a force to be reckoned with on the racetrack. The Boss® 302 was edged out of winning the 1969 Trans Am racing series in the car's inaugural season. But Parnelli Jones and George Follmer piloted their Boss® 302 Mustangs to the victory circle more than any other team in the hotly contested 1970 campaign, giving Ford the manufacturer's championship, all while the road going versions were building "street cred."

## Introduction

The Boss® 302's DNA of a unique 5.0-liter powertrain, superlative handling and a direct link to racing had built a legacy over the years that has come to epitomize what a high-performance Mustang is all about. To Ford's credit, no new Mustang would wear that name again until such time that the factory could put together all three race-inspired ingredients in a way that remains true to the Boss® 302's heritage.

That time is now.

Today, the Boss® 302 Mustang rides again for 2013 – both in name and the spirit of the original. Our thanks to Knudsen for the Boss Mustang legend, and to Shinoda for the looks and even the name itself. And now our thanks go to the men and women at Ford who have worked so hard to make sure that the new Boss® 302 is a legitimately worthy, race-bred successor of a Mustang performance legend!

-- John M. Clor

Author, *Mustang Dynasty*

### **BREAKING-IN YOUR VEHICLE**

Your vehicle requires a break-in period. Drive your new vehicle at least 100 miles (160 km) before performing extended wide open throttle maneuvers and at least 1,000 miles (1,600 km) before performance/competition conditions. Vary your speed frequently in order to give the moving parts a chance to break in.

## Boss® 302 Unique Features

### UNIQUE FEATURES

#### Boss® 302

- Boss® 302 high performance V8 engine
- Forged pistons and rods
- Runners in the box intake manifold
- CNC machined high-flow ported aluminum cylinder heads
- Steel-backed high RPM clutch
- Unique steering tuning
- Unique chassis tuning with manually-adjustable dampers
- Brembo four-piston front brakes with unique high-performance rear brake pads
- Low expansion brake hoses
- Unique upper grille with removable foglight delete covers
- Unique low-gloss black reflective hood and body side stripes
- Boss® 302 interior package with unique interior finish panels and instrument cluster with TFT screen and Mustang Track Apps (Recaro® seats optional)
- Quad exhaust with rear and side exiting pipes
- Unique staggered width 19x9 inch and 19x9.5 inch wheels with summer only performance tires
- 3.73 rear axle ratio with limited slip (optional Torsen® differential)
- High performance radiator and engine oil cooler
- AdvanceTrac® stability enhancement system with sport mode specifically calibrated and race track tuned. Refer to the *Driving* section in your *Owner's Manual* for more information.
- **TRACKEY™** - After delivery, your Ford dealer can reprogram your engine control module to use the red key as a **TRACKEY™** . Once enabled, the **TRACKEY™** provides optimal racetrack performance via a unique engine calibration. See <http://www.trackey.ford.com> for more information.

## **Boss® 302 Unique Features**

### **Boss® 302 with Laguna Seca® Package**

- Unique Laguna Seca® chassis tuning with manually-adjustable dampers
- Unique steering tuning
- Rear seat delete (creating a two-seat configuration) with added brace for improved body stiffness
- Boss® 302 interior package with standard Recaro® seats
- Unique staggered width 19x9 inch and 19x10 inch wheels with R-compound summer only performance tires
- 3.73 rear axle ratio with standard Torsen® differential
- Unique Sterling Grey body/interior accents
- Unique lower grille featuring larger hex pattern (only on the Laguna Seca®)
- Unique low-gloss metallic grey reflective hood and body side stripes
- Additional Ford Racing parts
  - Front splitter (track use only - see Warranty information for more details) The front splitter included in the Laguna Seca® Package is intended for race track use only and is not legal for on-street driving. It may degrade crash performance and void the vehicle warranty. The front splitter must be installed by the customer.
  - Front brake cooling kit
  - Transmission cooling scoop

## Boss® 302 Unique Features

### INSTRUMENT CLUSTER

Standard cluster shown, metric similar. Refer to the *Information Displays* chapter of your *Owner's Manual* for information on menus and Track Apps usage.

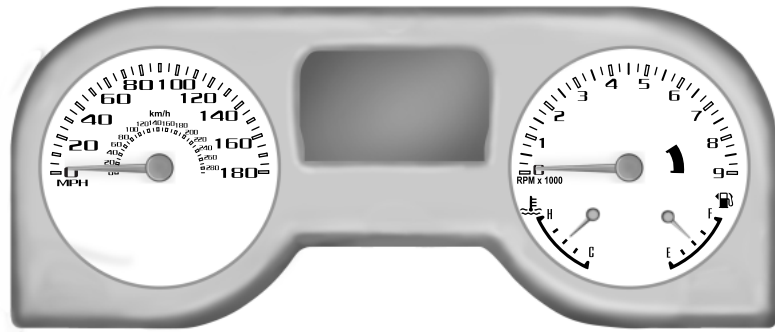



## Driving your Boss® 302

### ADVANCETRAC® STABILITY ENHANCEMENT SYSTEM

AdvanceTrac® sport mode

The AdvanceTrac® system provides an available sport mode specially calibrated for the Boss® 302 and its unique performance characteristics. This can be selected utilizing the stability control off switch. While in AdvanceTrac® sport mode, the selected steering option will be overridden and placed in sport mode. See the *Driving* section of the *Owner's Manual* for more information.

### DRIVING YOUR VEHICLE THROUGH WATER

The Boss® 302 has aerodynamic devices attached to the underbody designed to help control airflow for superior performance. Therefore, the driver must be especially careful to avoid driving through deep or standing water. If driving through deep or standing water is unavoidable, proceed very slowly. Never drive through water that is higher than the bottom of the wheel rims. Water may enter through the air intake due to the vacuum generated in the engine. Damage caused by the intake of water in the engine is not covered by the warranty. Refer to *Tire information* for more information.

### GROUND CLEARANCE



**Note:** Because of low vehicle ground clearance, use caution when approaching curbs/curb stops from the front and rear as vehicle damage will occur. Additionally, when crossing speed bumps or driveway curbs, Ford recommends approaching at a very low speed.

## Driving your Boss® 302

### WASHING YOUR VEHICLE

**Note:** Do not drive your vehicle through an automated, commercial car wash due to the vehicle's low ground clearance, tire width and track width. Wash your vehicle by hand, or by using a touchless commercial wash with no mechanical tracks on the floor. Do not use a commercial or high pressure wand on the striped surfaces or stripe edges.

### TRAILER TOWING



**WARNING:** Never tow a trailer with this vehicle. Your vehicle is not equipped to tow. No towing packages are available through an authorized dealer.

## Chassis

### SUSPENSION

- MacPherson strut with L-arm front suspension
- 8.8 inch solid rear axle with limited slip differential (3.73:1 ratio)

#### **Boss® 302:**

- 34.6 x 4.4 mm tubular front stabilizer bar
- 25.0 mm solid rear stabilizer bar
- Tokico twin tube adjustable shocks and struts
- 26.0 N/mm front and 32.4 N/mm rear coil springs

#### **Boss® 302 with Laguna Seca® package:**

- 34.6 x 4.4 mm tubular front stabilizer bar
- 26.0 mm solid rear stabilizer bar
- Tokico twin tube adjustable shocks and struts
- 24.0 N/mm front and 33.5 N/mm rear coil springs

### ADJUSTABLE SUSPENSION DAMPERS

Your vehicle has adjustable suspension dampers. The adjustment controls are located on top of the damping rods and can be adjusted with a small screwdriver. Remove the cap to access the control for the front strut.

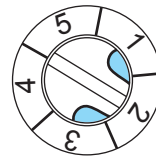

To access the rear shock, pull the carpet back in the trunk area. Then, lift the trim panel and pull rearward to expose the adjustable suspension damper.

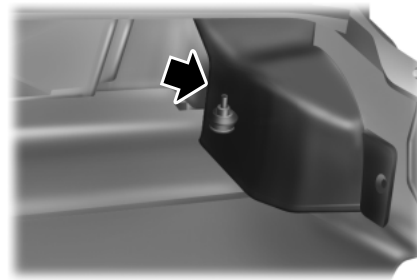

## **Chassis**

Position (1) has the lowest damping force which provides for a more comfortable ride. Position (5) has the highest damping force which provides more responsive handling. Position (2) is the factory setting (shown in graphic).

Left and right dampers should always be set to the same dial position. Front and rear can be adjusted independently to change vehicle response.

## Tire Information

### WHEELS

Your Boss® 302 is equipped with unique wheels matched to the tires. These wheels are more susceptible to damage due to their diameter, width and low profile tires. To avoid damage to your wheels:

- Maintain proper tire pressure (see *Tires* in this supplement).
- Do not drive your vehicle through an automated, commercial car wash due to the vehicle's low ground clearance, tire width and track width. Wash your vehicle by hand, or by using a touchless commercial wash with no mechanical tracks on the floor.
- When installing wheels, always torque lug nuts to specification with a torque wrench.
- Inspect your wheels for damage on a regular basis. If a wheel is damaged, replace it immediately.
- In the event that you encounter an abnormally harsh impact, inspect the outer edge of your wheels, both inside and out, for damage.

### Operating at High Speeds

Your Boss® 302 is capable of high speeds and is equipped with tires rated for the vehicle's maximum speed, electronically limited to 155 mph (250 km/h). Remember to drive safely, obey all traffic laws and only operate your vehicle at high speeds at locations equipped and designed to do so safely. Before operating your vehicle at high speeds:

- Ensure correct tire pressures (see *Tires* in this supplement).
- Inspect wheels and tires for wear and damage. Replace any damaged wheels or tires.
- Do not operate your vehicle at high speeds with more than two passengers or while carrying cargo.

### Wheel Lug Nut Torque Specifications



**WARNING:** When a wheel is installed, always remove any corrosion, dirt or foreign materials present on the mounting surfaces of the wheel or the surface of the wheel hub, brake drum or brake disc that contacts the wheel. Make sure that any fasteners that attach the rotor to the hub are secured so they do not interfere with the mounting surfaces of the wheel. Installing wheels without correct metal-to-metal contact at the wheel mounting surfaces can cause the wheel nuts to loosen and the wheel to come off while the vehicle is in motion, resulting in loss of control.

## Tire Information

Retighten the lug nuts to the specified torque at 500 miles (800 km) after any wheel disturbance (tire rotation, changing a flat tire, wheel removal, etc.).

Bolt size	Wheel lug nut torque*	
	ft-lb	N•m
½ x 20	100	135

\* Torque specifications are for nut and bolt threads free of dirt and rust. Use only Ford recommended replacement fasteners.

### IMPORTANT TIRE INFORMATION

Your vehicle is equipped with unique wheels and tires designed to enhance performance. To continue providing this performance, extra care must be taken when operating and maintaining your vehicle.

#### Wheels and Tires

Boss® 302	19 in. x 9.0 in. front, 19 in. x 9.5 in. rear cast aluminum wheels 255/40ZR19 front, 285/35ZR19 rear tires
Boss® 302 with Laguna Seca® Package	19 in. x 9.0 in. front, 19 in. x 10.0 in. rear lightweight cast aluminum wheels 255/40ZR19 front, 285/35ZR19 rear tires (ultra high performance)

#### Tires



**WARNING:** Snow tires must be the same size, load index, speed rating as those originally provided by Ford. Use of any tire or wheel not recommended by Ford can affect the safety and performance of your vehicle, which could result in an increased risk of loss of vehicle control, vehicle rollover, personal injury and death. Additionally, the use of non-recommended tires and wheels could cause steering, suspension, axle or transfer case/power transfer unit failure.

## Tire Information

The Mustang Boss 302 Laguna Seca package includes D.O.T. approved ultra high-performance summer tires with track capability. The rubber compounds used in these tires lose flexibility and may develop surface cracks in the tire tread area at temperatures below 20°F (-7°C). Always store your tires indoors at temperatures above 20°F (-7°C). If the tires have been subjected to 20°F (-7°C) or less, warm them in a heated space to at least 40°F (5°C) for at least 24 hours before installing them on a vehicle, or moving the vehicle with the tires installed, or checking tire inflation. Do not place tires near heaters or heating devices used to warm the room where the tires are stored. Do not apply heat or blow heated air directly on the tires. Always inspect the tires after storage periods and before use as outlined in the owner's manual. Ford does not recommend using the high performance summer tires on your Boss 302 or Boss 302 Laguna Seca edition when temperatures drop to approximately 40°F (5°C) or below, or in snow/ice conditions.



**WARNING:** If equipped with the Laguna Seca® Package, never drive with these tires in any wet conditions (rain, snow, ice, etc.) because they cannot channel water away and will slide risking serious injury.

- **Note:** Do not use tire chains on the original wheels and tires of your vehicle. The use of any type of tire chain on these tires may damage your vehicle.
- Always maintain your tire pressures according to the tire information placard on the driver's door jamb, using an accurate gauge.
- Tire pressures are specified "cold" and should be checked after the vehicle has been parked for at least 3 hours. Do not reduce pressure of warm tires.
- Check your tire pressure often to maintain it properly. Tire pressure can diminish over time and fluctuate with temperature.
- Do not overload your vehicle. Maximum vehicle and axle weights are listed on the tire information placard.
- Extra caution should be taken when operating the vehicle near its maximum load, including assuring proper tire pressure and reducing speeds.
- Extra caution should be taken when operating on rough roads to avoid impacts that could cause tire damage.
- In the event that you encounter an abnormally harsh impact, inspect your tires for damage.

## Tire Information

- Inspect your tires for damage on a regular basis. If a tire is damaged, replace it immediately.
- Proper suspension alignment is critical for maximum performance and optimal tire wear. If you notice uneven tire wear, have your alignment checked.
- When replacing tires, the only way to ensure original performance is to use the original equipment tire. If a different tire is used, it should be the same size, speed rating and load rating and be replaced as a set of four. Never mix tire brands.

### Winter Driving

The original equipment tires on your Boss® 302 are designed for high performance steering and handling. They are not designed for winter use on ice or snow and cannot be used with snow chains. If you will be operating your vehicle in these conditions, winter or all-season tires must be used.

Do not operate your vehicle above posted speed limits and never perform high speed driving with winter tires, even in clear, dry driving conditions.

### Tire Rotation

Because your vehicle is equipped with unique larger tires on the rear wheels, you can only rotate the tires side to side. You must not rotate tires in a crisscross pattern or front to rear. If you notice that the tires wear unevenly, have them checked.

The tires on your Boss® 302 should be rotated every 5,000 miles (8,000 km). This will help your tires wear more evenly, providing better tire performance and longer tire life.

The optional Laguna Seca® Package tires (255/40ZR19 front, 285/35ZR19 rear) are directional. Tire rotation is not recommended for directional tires.



## Tire Information

- Boss® 302 (non-Laguna Seca®) tire rotation (front tires at the top of the diagram)

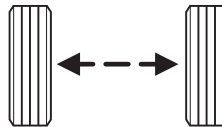
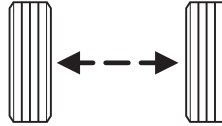

- Sometimes irregular tire wear can be corrected by rotating the tires.
- If your tires show uneven wear, ask an authorized dealer to check for and correct any wheel misalignment, tire imbalance or mechanical problem involved before tire rotation.
- After having your tires rotated, inflation pressure must be checked and adjusted to the vehicle requirements.

## Roadside Emergencies

### WRECKER TOWING

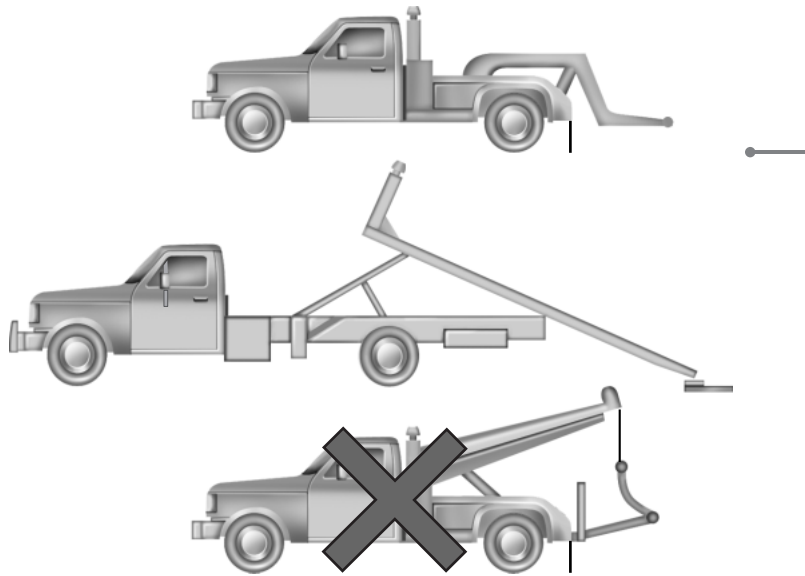

If you need to have your vehicle towed, contact your roadside assistance center or a professional towing service.

It is recommended that your vehicle be towed with a wheel lift and dollies or with flatbed equipment. When towing with a flatbed, 4x4 blocks must be used when loading/unloading your vehicle. Do not tow with a slingbelt. Ford Motor Company has not approved a slingbelt towing procedure.

**Note:** If the vehicle is towed by other means or incorrectly, vehicle damage may occur.

## Roadside Emergencies

### Wheel Lift

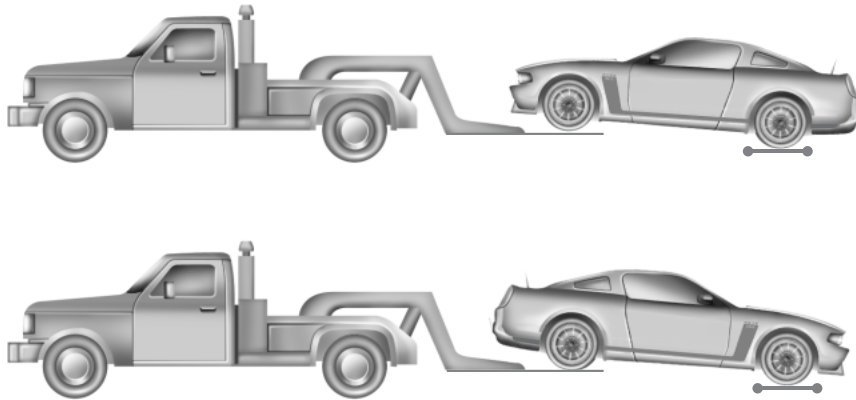

When towing the vehicle for front loading, the front tires must be 16 in. (41 cm) higher than the rear.

When towing the vehicle for rear loading, the rear tires must be 14 in. (35 cm) higher than the front.

## Roadside Emergencies

### Flatbed

The following diagram illustrates the maximum ramp angle allowable to load your vehicle on a flatbed. Vehicle damage may occur with greater angles.

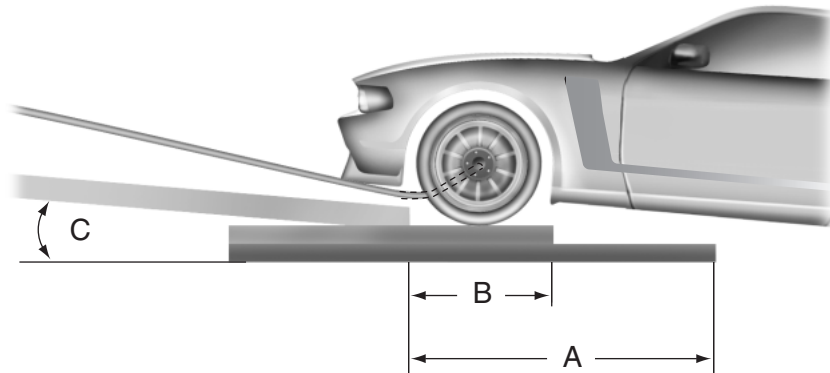

- A. 36 in. (91 cm) 4x4 loading block
- B. 18 in. (45.72 cm) 4x4 loading block
- C. 11.5° maximum

### **Securing the rear of the vehicle**

For flatbed towing, secure the rear of the vehicle by using axle straps or lasso straps around the rear axle. One strap is required on each side of the differential. **Note:** Using the standard T-slot attachment can damage the side exiting exhaust.

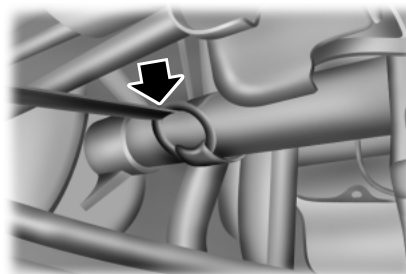

## Maintenance

### BOSS® 302 V8 ENGINE

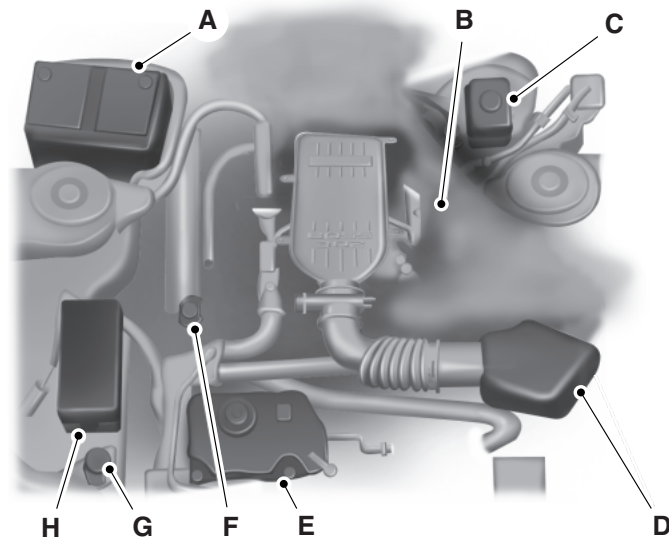

- A. Battery
- B. Engine oil dipstick
- C. Brake fluid reservoir
- D. Air filter assembly
- E. Engine coolant reservoir
- F. Engine oil filler cap
- G. Windshield washer reservoir filler cap
- H. Power distribution box

## Maintenance

### MOTORCRAFT PART NUMBERS

Component	Boss 302 engine
Engine drivebelt	JK6-678
Lightweight battery	BXT-96R-500

### ENGINE OIL RECOMMENDATION

Use Motorcraft® SAE 5W-50 full synthetic or an equivalent SAE 5W-50 full synthetic oil meeting Ford specification WSS-M2C931-B.

Do not use supplemental engine oil additives, cleaners or other engine treatments. They are unnecessary and could lead to engine damage that is not covered by Ford warranty.

Change your engine oil and filter according to the appropriate schedule listed in the *scheduled maintenance information*.

### DRIVETRAIN

Item	Description	
<b>Rear axle</b>	8.8 in. solid rear axle with limited-slip differential 3.73:1 ratio	
<b>Driveshaft</b>	2-piece steel	
<b>Transmission</b>	MT82 6-speed manual with integral clutch housing	
<b>Gear ratios</b>	<i>Gear</i>	<i>Ratio</i>
	1st	3.66
	2nd	2.43
	3rd	1.69
	4th	1.31
	5th	1.00
	6th	0.65
	Reverse	3.32

## Maintenance

### REAR SEAT DELETE PANELS (IF EQUIPPED)

In the event of battery failure, you can access the trunk area by doing the following:

1. Remove the two top fasteners by turning them counterclockwise.
2. Remove the trunk access panel (located behind the cross brace) by pulling it slightly down while pushing it rearward (toward the trunk).

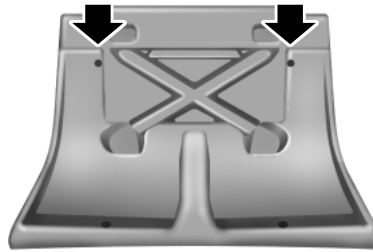

To remove the rear floor panel, do the following:

1. Remove the two top fasteners by turning them counterclockwise.
2. Lift the top of the two bottom fasteners with a flat-end screwdriver, then remove them.
3. Remove the rear floor panel.
4. Remove the trunk access panel (located behind the cross brace) by pulling it slightly down while pushing it rearward (toward the trunk).

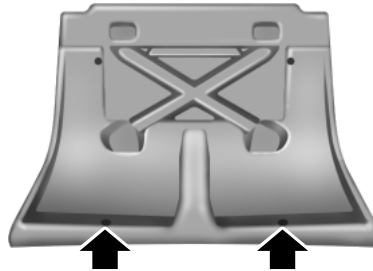

## Capacities and Specifications

### TECHNICAL SPECIFICATIONS

Item	Capacity	Ford part name or equivalent	Ford part number / Ford Specification
Brake fluid	Between MIN and MAX lines on reservoir	Motorcraft® High Performance DOT 3 Motor Vehicle Brake Fluid	PM-1-C / WSS-M6C62-A or WSS-M6C65-A1
Engine oil (includes filter change)	8.5 quarts (8.0L)	Motorcraft® 5W-50 Full Synthetic Motor Oil	XO-5W50-QGT / WSS-M2C931-B
Engine coolant <sup>1</sup>	15.2 quarts (14.4L)	Motorcraft® Orange Antifreeze/Coolant Prediluted	VC-3DIL-B (US) CVC-3DIL-B (Canada) / WSS-M97B44-D2
Rear axle lubricant <sup>2</sup>	5.0 pints (2.4L)	Motorcraft® SAE 75W-140 High Performance Synthetic Rear Axle Lubricant	XY-75W140-QL / WSL-M2C192-A
Rear axle fluid friction modifier	5 oz (148ml)	Additive Friction Modifier	XL-3 EST-M2C118-A
Fuel tank	16.0 gallons (60.5L)	—	—
Manual transmission fluid <sup>3</sup>	2.75 quarts (2.6L) <sup>3</sup>	Motorcraft® Full Synthetic Manual Transmission Fluid	XT-M5-QS / WSD-M2C200-C



## Capacities and Specifications

Item	Capacity	Ford part name or equivalent	Ford part number / Ford Specification
Windshield washer fluid	Fill as required	Motorcraft® Premium Windshield Washer Concentrate (US) / Premium Quality Windshield Washer Fluid (Canada)	ZC-32-A (US) CXC-37-(A, B, D, and F) (Canada) / WSB-M8B16-A2 / - -

<sup>1</sup>Add the coolant type originally equipped in your vehicle.

<sup>2</sup>Rear axle lubricants do not need to be checked or changed unless a leak is suspected, service is required, the axle assembly has been submerged in water, or when subjecting your car to high-speed and/or competition use. The axle lubricant and friction modifier should be changed any time the rear axle has been submerged in water. The axle lubricant and friction modifier should also be changed after the initial (first) hour of high-speed operation or if the vehicle is subjected to track or competition conditions; thereafter changing the axle lubricant and friction modifier every 12 hours (under these conditions).

Fill 1/4 - 9/16 inch (6-14 mm) below bottom of fill hole.

<sup>3</sup>Fill to within 1/8 inch (3 mm) of bottom of fill hole.

## Capacities and Specifications

### ENGINE INFORMATION

Item	Description
<b>Configuration</b>	90-degree V8 Aluminum block Aluminum high flow cylinder heads Engine weight - 444 lb. (201 kg)
<b>Bore x stroke</b>	92.2 x 92.7 mm (3.63 x 3.65 inches)
<b>Displacement</b>	302 cubic inches (5.0L)
<b>Compression ratio</b>	11.0:1
<b>Valve train</b>	Compact RFF (roller finger followers) Four valves per cylinder
<b>Cam timing</b>	Twin independent variable
<b>Fuel system</b>	Sequential mechanical returnless fuel injection
<b>Ignition system</b>	Coil on plug, two knock sensors
<b>Firing order</b>	1-5-4-8-6-3-7-2
<b>Throttle body</b>	Single bore 80 mm
<b>Pistons</b>	Forged aluminum
<b>Crankshaft</b>	Fully counterweighted forged steel
<b>Connecting rods</b>	High strength forged powder metal/floating pin
<b>Intake manifold</b>	Runners in a box composite
<b>Exhaust manifolds</b>	Pulse separated stainless steel tubular headers

## Capacities and Specifications

### Engine Drivebelt Routing

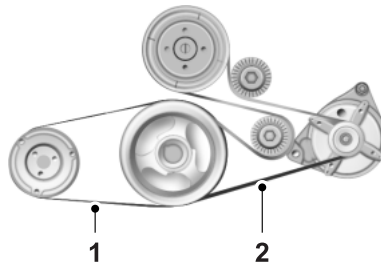

1. Short drivebelt is on first pulley groove closest to engine.
2. Long drivebelt is on second pulley groove farthest from engine.

## Track Use Preparation

### TRACK PREPARATION

The Boss® 302 and Boss® 302 Laguna Seca® edition have been rigorously proven out on race tracks. Below are recommendations for optimizing your Boss® 302 for a track day event.

- For optimal performance, premium fuel is recommended.
- Change brake fluid to Super DOT 4 to improve track performance of braking system (WSS-M6C65-A2), Ford part number (YS4Z-19542-AA).
- Install Ford Racing front brake cooling kit (M-2004-MB) to improve brake cooling (standard on Laguna Seca® edition).
- Remove rear brake dust shields to improve brake cooling.
- Install Ford Racing transmission cooling scoop (M-5025-MBR) to improve transmission cooling (standard on Laguna Seca® edition).
- During extended track sessions in extreme temperatures or conditions, your Boss 302 may require additional engine cooling actions. If the water temperature warning light illuminates, return to the paddock and let the vehicle return to normal operating temperature while idling before turning the engine off. Prior to the next session, remove the round fog light delete covers from the upper grille. This will allow more cooling air to the radiator and allow the car to run extended sessions in extreme heat. Visit [fordracing.com](http://fordracing.com) for additional parts to further enhance the powertrain cooling on your Boss 302.
- For extended track use, Ford recommends installing a rear differential cooler to improve rear axle cooling.
- The Ford Racing front splitter kit (M-16601P-MBA, standard on Laguna Seca® edition) can be installed to improve high-speed vehicle stability and handling. If the Ford Racing front splitter kit will be installed on a Boss 302 without the Laguna Seca® package, Ford recommends installing the Laguna Seca® edition rear spoiler in place of the standard rear spoiler to maintain aerodynamic balance. The unique lower grille from the Laguna Seca® edition should also be installed to accommodate the splitter support rods. This front splitter is intended for race track use only and is not legal for on-street driving. It may degrade crash performance and void the vehicle warranty. The front splitter must be installed by the customer.

## Track Use Preparation

- For track sessions, it is recommended to run 41 psi (283 kPa) hot for the original equipment manufacturer tires, front and rear.
  - Depending on track temperature, ambient temperature and driving style, you may need to reduce the starting tire pressure by as much as 4 psi (27 kPa).
  - The starting pressure may be lower in the rear tires relative to the front tires to achieve 41 psi (283 kPa) hot.
  - Reset tire pressures to placard recommended pressures before leaving the track.
- For improved track performance, Ford recommends **TRACKKEY™**, available through Ford Racing. See your local Ford dealer or go to <http://www.trackkey.ford.com> for more information (M-14204-MBTKA).
- Your Boss® 302 is equipped from the factory with Brembo 4-piston front calipers and unique, high-performance rear brake pads that will provide excellent performance under normal driving conditions. Ford recommends the following bedding procedure for race track driving be followed.

### **Brake burnishing procedure for race track driving**

If the vehicle has to be driven on a track (racing) or in severe driving conditions, the following steps must be performed on a closed course, not on public roads:

- Burnish: 30 burnish stops at 60-0 mph (96-0 km/h), 0.4g deceleration, one mile (1.6 km) between stops. If the vehicle has more than 200 miles (322 km) on the brakes, skip this step and proceed to the Fade stops.
- Fade: 20 fade stops, at 65-0 mph (105-0 km/h), 0.85g deceleration or just below ABS activity, no dwell between stops
- Cool down: Minimum of five mile (8 km) cool down route, if on public roads (no brakes) run at 60 mph (96 km/h)
- Recovery: 30 recovery stops at 60-0 mph (96-0 km/h), 0.4 g deceleration, one mile (1.6 km) between stops
- Cool down: Minimum of five mile (8 km) cool down route, if on public roads (no brakes) run at 60 mph (96 km/h)

## Track Use Preparation

### **Damper adjustment recommendations:**

- Boss® 302 - Set all four dampers to position (5) for all tracks.
- Boss® 302 Laguna Seca® edition - Set front dampers to position (5) and set the rear dampers to position (3), (4) or (5) depending on how smooth the track is or how much curbing the driver likes to use.
  - On a rough track, set the rear dampers to position (3).
  - On a smooth track with aggressive apex curbs, set the rear dampers to position (4), but only if the driver uses those curbs.
  - On a smooth track with mild FIA-type apex curbs, set the rear dampers to position (5).
- If the turn-in portions of the track are rough, reduce the front damper setting by one position until the Boss® 302 turns in on those rough portions.
- If the rear of the car is skipping over bumps during corner exit so that the driver has to reduce throttle input, reduce the rear damper setting by one position until the driver can apply appropriate throttle.

**Note:** Restore the vehicle to factory specifications prior to driving on public roads.

## Warranty Coverage

### WARRANTY COVERAGE

The Boss® 302 carries the same warranty as other Ford Mustang models, which is covered in its entirety in the Ford Motor Company Warranty Guide.

The three unique Laguna Seca® Package high performance parts (front splitter, front brake cooling kit, and transmission cooling scoop) are warranted by Ford Racing against defects in material and workmanship for 3 years / 36,000 miles (whichever occurs first) from the vehicle warranty start date; and are not covered by the terms of the New Vehicle Limited Warranty (as outlined in the Boss® 302 Laguna Seca – Dealer Installation Waiver).

Warranty service for the Boss® 302 can be obtained at any Ford dealer nationwide.

Ford does not recommend modifying or racing Ford vehicles, as they are designed and built to be driven as delivered from the factory. The Ford Motor Company Warranty Guide discusses vehicle usage and the installation of aftermarket parts and their effect on warranty coverage.

Please see the Warranty Guide for complete information.

In the event the vehicle is intended for track use, and the loss of warranty coverage is not of concern, the following vehicle durability modification is required:

- **Note:** Ford recommends that you change your axle lubricant and friction modifier after the initial (first) hour of high-speed operation or if the vehicle is subjected to track or competition conditions; thereafter changing the axle lubricant and friction modifier every 12 hours (under these conditions).
- **Note:** Ford recommends you change your oil and filter after your vehicle is subjected to track and/or competition conditions.

Additionally, perform multi-point inspection and the maintenance outlined in the 150,000 mile (240,000 km) normal maintenance schedule of the *scheduled maintenance information* after track use. Refer to the vehicle service manual for removal and installation procedures. Replace with Genuine Ford and Motorcraft® service parts as needed.

These modifications may not necessarily protect your engine from damage in competition conditions. Subjecting your vehicle to competition conditions even with these proposed modifications may render repairs non-reimbursable under the warranty.

