

NOTICE: This document contains references to Varian. Please note that Varian, Inc. is now part of Agilent Technologies. For more information, go to www.agilent.com/chem.



Ion Chamber Replacement for VS Series Leak Detector

*FIELD INSTALLATION
INSTRUCTIONS*

Part Number 699910016
Rev. A
December 2008

Varian Field Instruction Sheet

Ion Chamber Replacement for VS Series Leak Detector

Preface

Documentation Standards

This manual uses the following documentation standards:

NOTE



Notes contain important information.

CAUTION



Cautions appear before instructions, which if not followed, could cause damage to the equipment or data loss.

WARNING



Warnings appear for a particular procedure or practice which, if not followed correctly, could lead to serious injury or death.

Hazard and Safety Information

The common international symbols used in this manual and on the equipment are defined below.



OFF Supply (Power)



Earth (Ground) Terminal



ON Supply (Power)



Caution, Hot Surface



AC – Alternating Current



Caution, Risk of Electrical Shock



Warning, Risk of danger



Protective Conductor Terminal



Frame or chassis Terminal



Operators and service personnel must be aware of all hazards associated with this equipment. They must know how to recognize hazardous and potentially hazardous conditions, and know how to avoid them. The consequences of unskilled, improper, or careless operation of the equipment can be serious. Every operator or service person must read and thoroughly understand operation/maintenance manuals and any additional information provided by Varian. All warning and cautions must be read carefully and strictly observed. Consult local, state, and national agencies regarding specific requirements and regulations. Address any safety, operation, and/or maintenance questions to your nearest Varian office.

Solvents

WARNING



The mechanical components of leak detectors may be cleaned with one of the recommended solvents. When heated, sprayed, or exposed to high-temperature equipment, these solvents become flammable and explosive, causing serious injury or death. Do not use these solvents near a high-temperature source. Ventilate the working area with a blower and work in a large, well-ventilated room.

Solvents are irritants, narcotics, depressants and/or carcinogens. Their inhalation and/or ingestion may produce serious side effects. Prolonged or continued contact with the skin results in absorption through the skin and moderate toxicity. Always ensure that cleaning operations are carried out in large, well-ventilated rooms, and wear eye shields, gloves, and protective clothing.

Due to the effective cleaning nature of VacuSolv solvent and its residue-free properties, Varian' Component and Spectrometer Cleaning Kit (Part Number 670029096), used in accordance with the kit instructions, is recommended for cleaning spectrometer components. The kit can also be used for fine cleaning of other parts in the leak detector's vacuum system such as valves and fittings. No rinsing steps or high-temperature drying is required following cleaning with VacuSolv. Although appropriate precautions are advised, VacuSolv is compatible with most materials and does not contain toxic chemicals or CFCs (chlorofluorocarbons). Other acceptable solvents are isopropyl alcohol (IPA) or Dow Corning® OS-20.

To clean the leak detector plastic enclosure, the LCD display and Front Panel buttons, use only a soft cloth slightly dampened with water or a mild soap.

Do NOT use excess water or cleaning solvents of any kind.

Avoid splashing any cleaning solvents into the unit through the ventilation openings or Front Panel buttons. Wipe the surface with a dry lint-free cloth.

Vacuum Equipment and Cleanliness

Cleanliness is vital when servicing the leak detector or any vacuum equipment. There are some techniques that are more important in leak detector servicing than in general vacuum work:

CAUTION



Wear non-powdered, ESD-safe Nitrile or equivalent gloves to prevent skin oils from getting on spectrometer internal components.

O-ring Care

When removing, checking or replacing O-rings, keep in mind the following:

NOTE



Varian recommends replacing all O-rings during routine maintenance or during any maintenance procedure requiring that O-rings be removed.

CAUTION



Remove O-rings carefully with your fingers. Do not use metal tools for this task; this prevents scratching of any sealing surfaces.

- Wipe all O-rings clean with a lint-free cloth before installation to ensure that no foreign matter is present to impair the seal.
- Do not use grease or any other substance on O-rings that will come in contact with the vacuum surfaces.
- Do not use alcohol, methanol or other solvents on O-rings. Doing so causes deterioration and reduces their ability to hold a vacuum.
- Varian does not recommend the use of vacuum grease. If applicable, apply a small amount of Apiezon[®] L grease and wipe the O-rings shiny dry.

Metal Seal Care

CAUTION



Metal Seals must be replaced any time a spectrometer is opened. All fasteners must be installed and torqued per assembly procedure specifications. Remove Metal Seals carefully with your fingers or a soft tool. Metal tools scratch sealing surfaces.

- Metal Seals are supplied in pre-cleaned condition. No cleaning is required. If necessary, Metal Seals can be cleaned using the recommended solvents. Wipe Metal Seals clean with a lint-free cloth before installation to ensure that no foreign matter impairs the seal.
- Do not use grease or any other substance on Metal Seals that will come in contact with the spectrometer.

Spectrometer

CAUTION



Store the Ion Source/Preamplifier sub-assembly in a cool, dry area in a tightly sealed, ESD protected container. Wear non-powdered, ESD-safe Nitride or equivalent gloves when handling the spectrometer. Wash hands thoroughly after handling the spectrometer filaments and especially before smoking or eating.

The spectrometer and PCB's are static sensitive devices. Wear a grounding strap when performing any maintenance on these units and especially when performing maintenance of static sensitive parts.

CAUTION



The spectrometer operates at a very high vacuum produced by the high vacuum turbomolecular pump. Service of the spectrometer requires that this vacuum be vented to the atmosphere.

Equipment Required

- Extended Length M5 Allen Wrench
- Metric Allen Wrench Set (Range 1.5 mm to 10 mm)
- Needle nose pliers or tweezer
- M3 Phillips Head Screw Driver
- 1.5 mm Hex Driver
- 5 mm Hex Driver
- Torque Wrench (must be adjustable to 45 in-lbs (5.0 N-m) and 90 in-lbs (10.2 N-m))
- Digital Multimeter (Fluke 187 or equivalent)

Installation Procedure

NOTE



Inspect the new ion source kit for deformation, damage and filament coating flaking prior to installation. Do not install if damaged. Touching the filament under any condition will cause damage.

For clarity, some items have been omitted from views.

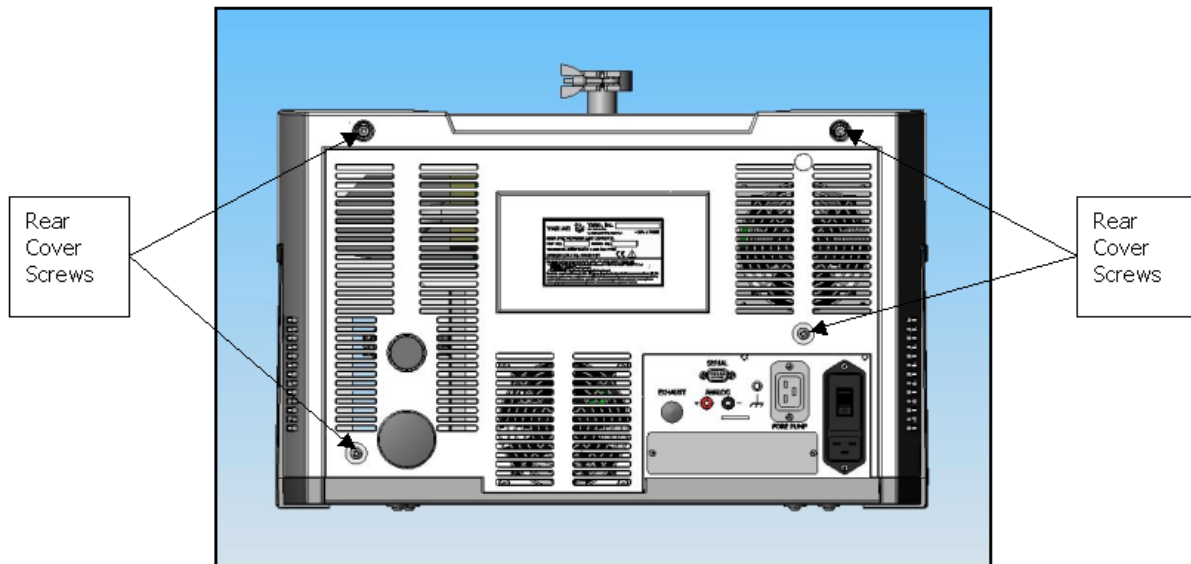

Figure 1: Rear Screws

1. Turn off the power switch located on the back of the unit and unplug.
2. Wait 30 seconds for the high voltage to dissipate.
3. Using an extended length M5 Allen wrench, remove the four screws holding the rear plastic cover (Figure 1: Rear Screws).
4. Detach the rear plastic cover from the unit.

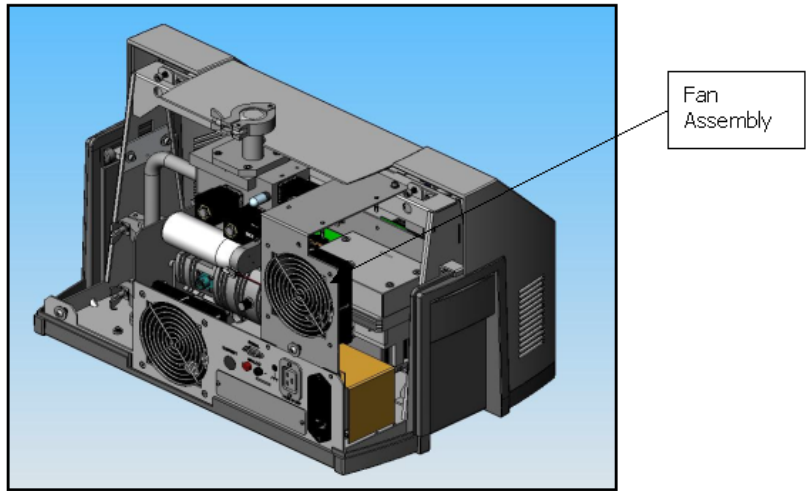

Figure 2: Fan Assembly

5. Disconnect the fan cable and remove the fan assembly by unfastening two wing nuts and one M4 socket head cap screw (Figure 2: Fan Assembly).

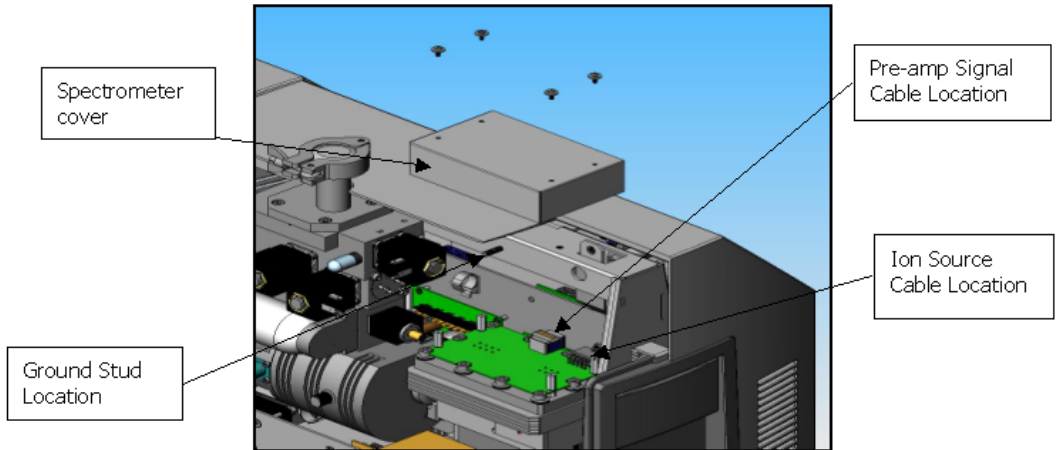

Figure 3: Cable Locations

CAUTION



Static sensitive device, ensure that personnel are properly grounded before proceeding.

6. Disconnect the spectrometer ground cable, the preamp signal cable and the ion source cable from the spectrometer (Figure 3: Cable Locations).

NOTE



Cables not shown for clarity.

7. Using an M3 Phillips screw driver, remove the spectrometer cover.

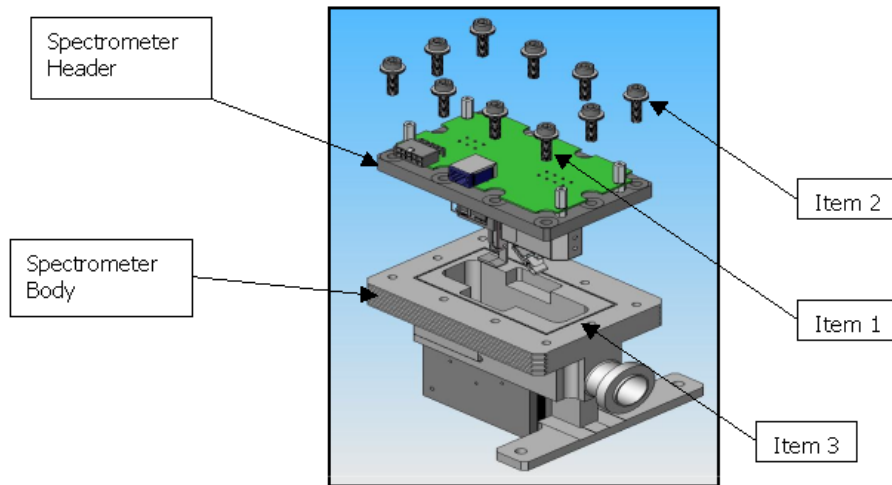

Figure 4: Spectrometer Exploded View

CAUTION



Wear non-powdered, ESD-safe Nitride or equivalent gloves (not included in kit) to prevent skin oils from getting on vacuum surfaces. Ensure that personnel are properly grounded before proceeding.

8. Use an M5 allen wrench to loosen screws (item 1) and carefully remove the spectrometer header from the body. The vacuum system vents to atmosphere as the screws are loosened. Retain the socket head cap screws (item 1) and the Belleville washers (item 2). See line item 21 for correct orientation of the Belleville washers (Figure 10: Direction of Cone).
9. Remove the metal gasket (item 3) and discard. Do not scratch the mating surface when removing the gasket. Do not attempt to reuse the gasket (Figure 4: Spectrometer Exploded View).
10. Examine the spectrometer cavity for discolored areas. If present, refer to the service manual for cleaning instruction.

CAUTION



This is a static sensitive device, ensure that personnel are properly grounded before proceeding.

11. Use an M1.5 Allen wrench to unscrew the six coupler screws and the collimator screw (Figure 5: Ion Support Assembly).

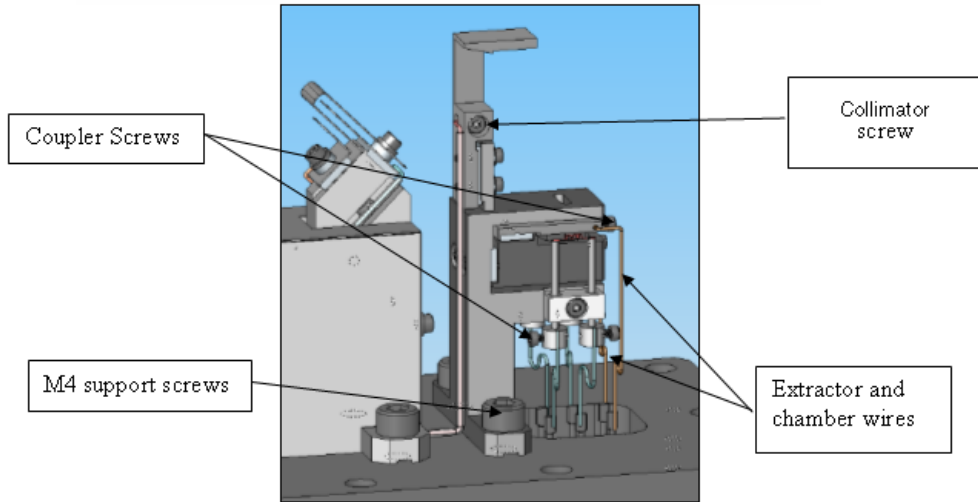

Figure 5: Ion Support Assembly

12. Remove the two M4 support screws (Figure 6: M4 Screws).

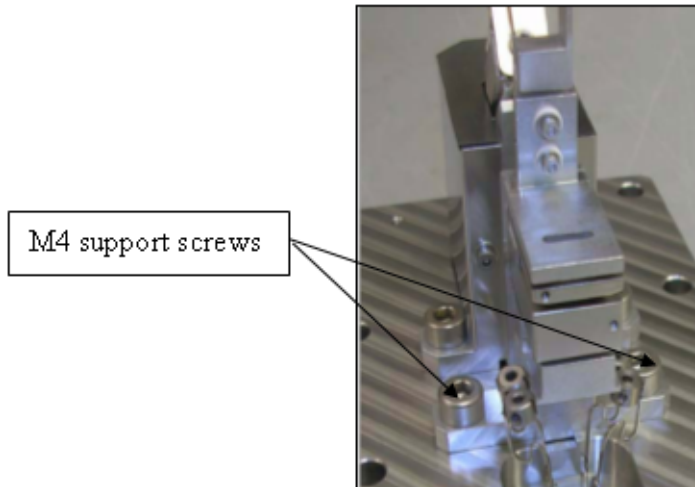

Figure 6: M4 Screws

13. Gently remove the ion assembly from the spectrometer header (Figure 7: Partial Pressure Plate).

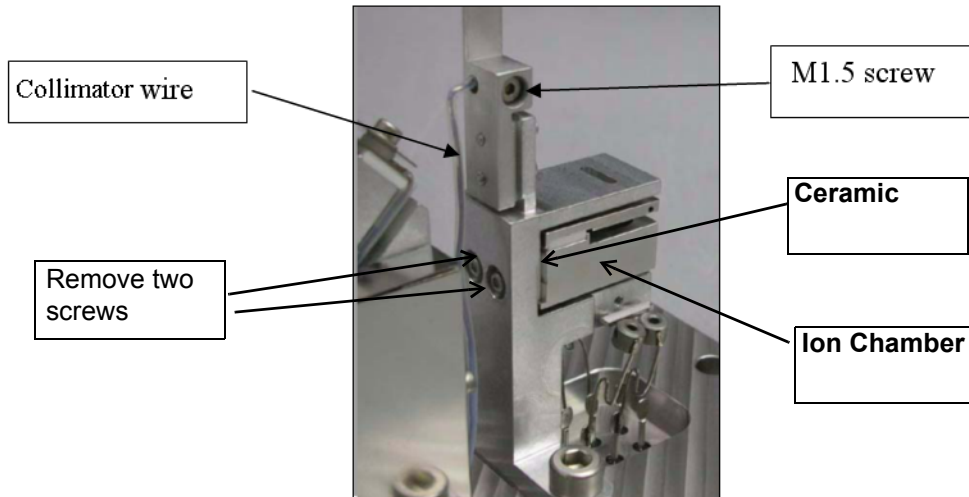

Figure 7: Partial Pressure Plate

14. Loosen the two screws on the rear and slide the ion chamber out.

15. Slide in the new ion chamber, aligning the ceramic spacer with the chamber. Tighten the two screws.

CAUTION Ensure that no damage is done to the filaments.



16. Position the ion support assembly onto the spectrometer header and align.

17. Secure to the spectrometer header using two M4 support screws.

18. Connect the collimator wire to the collimator plate using an M1.5 screw (Figure 7: Partial Pressure Plate).

19. Insert the chamber and extractor wires into the ion support assembly (Figure 8: Extractor Plate).

CAUTION Do not cut the wires by over tightening. Ensure that wires are contacting the assembly where required and that no short circuit exists.

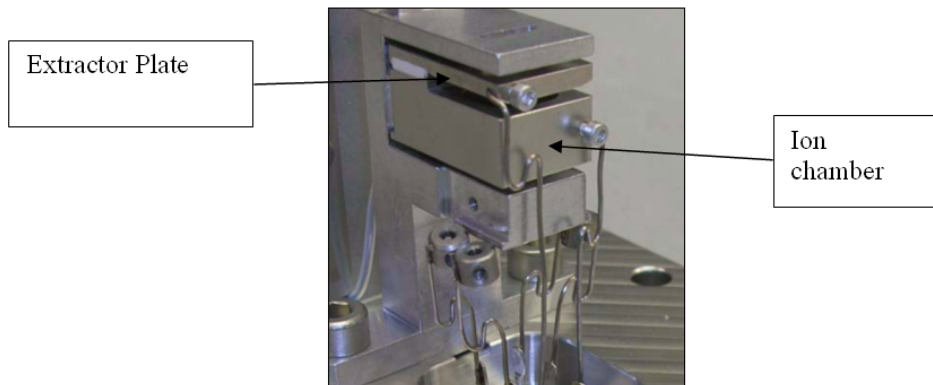

Figure 8: Extractor Plate

20. Clean the mating surfaces of the spectrometer body and header with Isopropyl alcohol and a clean lint free wipe.

NOTE



Varian recommends that you use the Vac-u-solv spectrometer cleaning kit (PN: 670029096).

21. Center replacement metal gasket inside the bolt pattern and outside of the body cavity. To prevent scratching of any sealing surface do not use metal tools for this task.
22. Guide the spectrometer header into pocket with the detector housing closest to the inlet (Figure 9: Spectrometer Alignment).

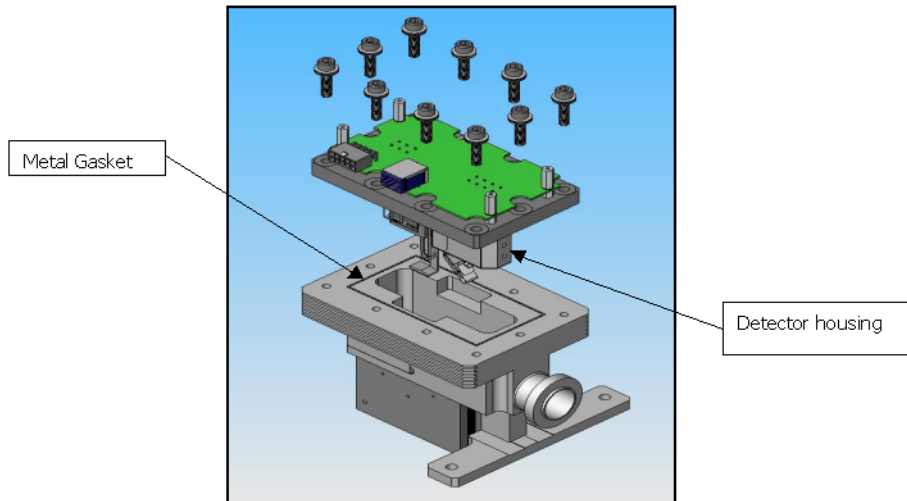

Figure 9: Spectrometer Alignment

23. Insert a screw with three Belleville washers into each hole and finger tighten (Figure 10: Direction of Cone).

NOTE



The cones of the Belleville washers should all point to the head of the screw.

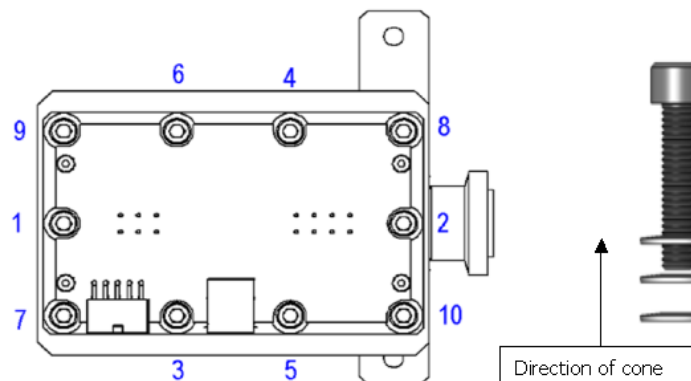

Figure 10: Direction of Cone

24. Following the pattern shown in Figure 10: Direction of Cone, torque screws to 45 in-lbs (5.0 N-m).
25. Re-torque screws to 90 in-lbs (10.2 N-m) following the same pattern. Go through the entire torque pattern twice to ensure the metal gasket is firmly compressed.
26. Wait a minimum of five minutes then torque the screws shown in pattern (Figure 10: Direction of Cone) to 90 in-lbs (10.2 N-m).
27. On the PCB, use the resistance meter to verify an open circuit between any two of the six ion source header pins (except FIL-1 to FIL-1 and FIL-2 to FIL-2 which should be 0.3 Ohms or less). Also verify an open circuit between the body of the spectrometer and any of the ion source header pins (Figure 11: Ion Source Header Pin Schematic). If there is continuity (short circuit) at any of the points, remove the header and inspect for shorting.

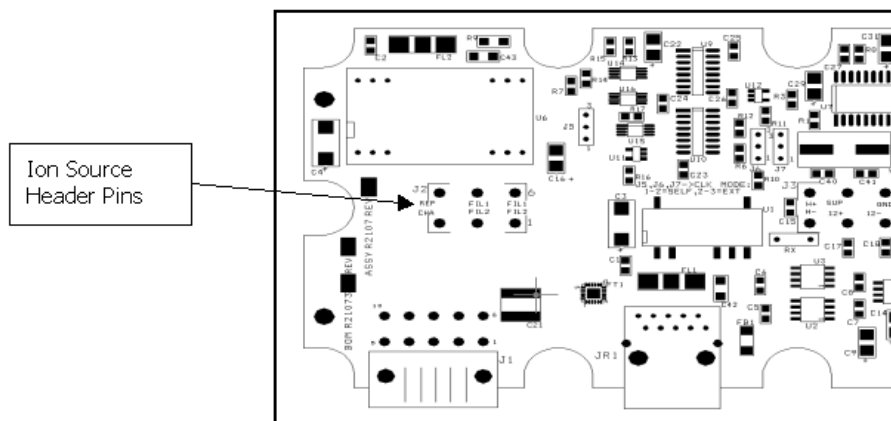

Figure 11: Ion Source Header Pin Schematic

28. Place the spectrometer cover over the header and align the holes (Figure 12: Ion Source Header Pin Locations).

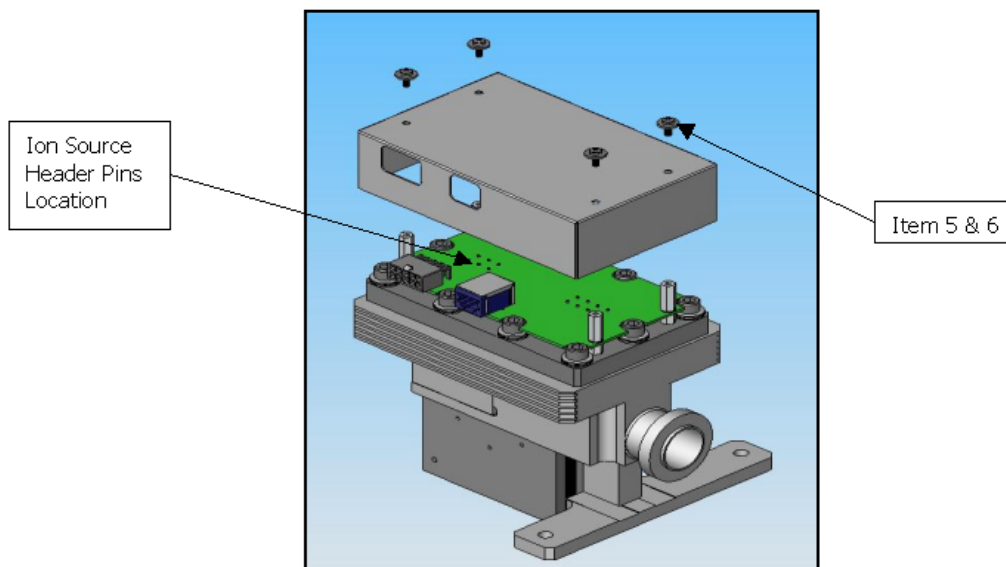

Figure 12: Ion Source Header Pin Locations

29. Install screws and washers (items 5 & 6), then tighten using a M3 Phillips screw driver (Figure 12: Ion Source Header Pin Locations).

30. Connect the spectrometer ground cable, the preamp signal cable and the ion source cable to the spectrometer cover.
31. Ensure that the vent valve on the turbo molecular pump (if installed) is tightened (Figure 13: Vent Valve).

NOTE

The vent valve is not installed on most turbo pumps.



Vent Valve

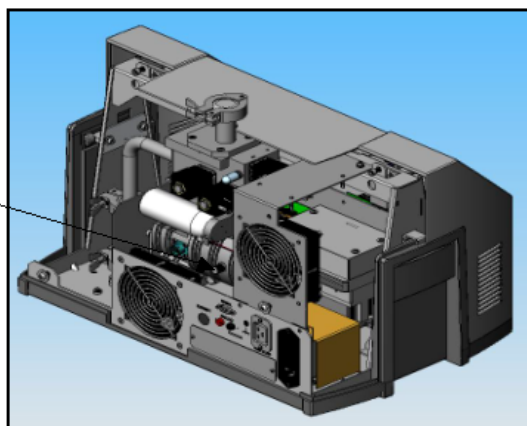

Figure 13: Vent Valve

32. Attach the fan assembly (Figure 2: Fan Assembly) by fastening two wing nuts and one M4 socket head cap screw. Then connect the fan cable to the unit.
33. Leak check the spectrometer to ensure a leak free joint.
34. Attach the rear cover and secure to the unit using existing hardware.
35. Power up the unit.
36. Watch the Home screen to verify that the *Spectube Pressure Wait* message progresses to *Stabilization Wait* and *System Ready* within ten minutes. Refer to the user manual if the system fails to reach the *System Ready* mode. The filament emission current normally operates at 0.8mA.
37. Use the display menus (MENUS, SET-UP, MANUAL TUNING, EMISSION) to set the emission to .8 mA.

NOTE

Varian recommends that you wait a minimum of 30 minutes for the vacuum system to clean up to obtain optimum calibration.



38. Calibrate the system per the user manual. For proper operation the system must be calibrated after opening the spectrometer or changing a filament.
39. If the system fails calibration, adjust the filament emission current as follows:
 - If gain is too low, there is too much signal; reduce emission current (by 0.1 - 0.2mA), then calibrate again.
 - If gain is too high, there is too little signal; increase emission, then calibrate again.
 The permitted emission current range is from 0.5 to 1.5 mA.
 When calibration is successful, filament replacement is complete.

Sales and Service Offices

Canada

Central coordination through: Varian, Inc.

121 Hartwell Avenue
Lexington, MA 02421
USA
Tel.: +1 781 861 7200
Toll-Free: +1 800 882 7426
Fax: +1 781 860 5437

China

Varian Technologies China, Ltd.

Room 1648
Central Tower South Wing
Beijing Junefield Plaza
No. 10 XuanWuMenWai Street
Beijing 100052
P. R. China
Tel.: +86 (10) 6310 8550
Toll-Free: 800 820 6556
Fax: +86 (10) 6310 0141

France

Varian s.a.

7 avenue des Tropiques
Z.A. de Courtaboeuf - B.P. 12
91941 Les Ulis cedex
France
Tel.: +33 (0) 1 69 86 38 84
Fax: +33 (0) 1 69 86 29 88

Benelux

Varian Vacuum Technologies

Herculesweg 8
4338 PL Middelburg
The Netherlands
Tel.: +31 118 671570
Fax: +31 118 671569

Germany & Austria

Varian Deutschland GmbH

Alsfelder Strasse 6
Postfach 11 14 35
64289 Darmstadt
Germany
Tel.: +49 (0) 6151 703 353
Fax: +49 (0) 6151 703 302

India

Varian India Pvt. Ltd.

205-A, "A" wing of Galleria
2nd floor, Hiranandani Gardens
Powai, Mumbai-400 076
India
Tel.: +91 22 2570 8595/8597
Fax: +91 22 2570 8599
Mobile: +91 98 679 55969

Italy

Varian, Inc.

via F.lli Varian 54
10040 Leini, (Torino)
Italy
Tel.: +39 011 997 9111
Toll-Free: 00 800 234 234 00
Fax: +39 011 997 9350

Japan

Varian Technologies Japan, Ltd.

8th Floor
Sumitomo Shibaura Building
4-16-36 Shibaura Minato-ku
Tokyo 108
Japan
Tel.: +81 3 5232 1253
Toll-Free: 0120 655 040
Fax: +81 3 5232 1710

Korea

Varian Technologies Korea, Ltd.

Shinsa 2nd Bldg. 2F
966-5 Daechi-dong
Kangnam-gu, Seoul
Korea 135-280
Tel.: +82 2 3452 2452
Toll-Free: 080 222 2452
Fax: +82 2 3452 2451

Mexico

Varian, S. de R.L. de C.V.

Concepcion Beistegui No 109
Col Del Valle
C.P. 03100
Mexico, D.F.
Tel.: +52 5 523 9465
Fax: +52 5 523 9472

Taiwan

Varian Technologies Asia, Ltd.

14F-6, No. 77, Hsin Tai Wu Road, Sec. 1
Hsi chih, Taipei Hsien
Taiwan, R.O.C.
Tel.: +886 2 2698 9555
Toll Free: 0800 051 342
Fax: +886 2 2698 96782

UK & Ireland

Varian Ltd.

6 Mead Road
Oxford Industrial Park
Yarnton, Oxford OX5 1QU
UK
Tel.: +44 (0) 1865 291570
Fax: +44 (0) 1865 291571

United States

Varian, Inc

121 Hartwell Avenue
Lexington, MA 02421
USA
Tel.: +1 781 861 7200
Toll-Free: +1 800 882 7426
Fax: +1 781 860 5437

Other Countries

Varian Vacuum Technologies

via F.lli Varian 54
10040 Leini, (Torino)
Italy
Tel: (39) 011 997 9 111
Fax: (39) 011 997 9 350

Customer Support and Service:

North America

Tel: 1 (800) 882-7426 (toll-free)
vtl.technical.support@varianinc.com

Europe

Tel: 00 (800) 234 234 00 (toll-free)
vtl.technical.support@varianinc.com

Japan

Tel: (81) 3 5232 1253 (dedicated line)
vtj.technical.support@varianinc.com

Korea

Tel (82) 2 3452 2452 (dedicated line)
vtk.technical.support@varianinc.com

Taiwan

Tel: 0 (800) 051 342 (toll-free)
vtw.technical.support@varianinc.com

Worldwide Web Site, Catalog and On-line Orders:

www.varianinc.com

Representatives in most countries



VARIAN