

TBird* Ventilator Series

SERVICE MANUAL

Bird Products Corporation

L1314 Rev. B

April 2000

*TBird is a registered trademark in the U.S. and some other countries.



Bird Products Corporation	MANUAL REVISION HISTORY	TBird Ventilator Series Service Manual
Date	Revision	Pages
November, 1996	Rev. A	
April, 2000	Rev. B	i, iv, v, xv Appendix , L1465



USER RESPONSIBILITY WARNING

This service manual is intended for use by Bird Products Corporation trained and authorized service personnel. Bird Products Corporation does not condone or approve of service activity on its products by other than Bird Products Corporation trained or authorized personnel. BIRD PRODUCTS CORPORATION IS NOT RESPONSIBLE FOR ANY UNAUTHORIZED REPAIRS, OR ANY REPAIRS MADE BY UNAUTHORIZED PROCEDURES.

Use of the incorrect part or the failure to exercise due care in the installation, removal, servicing, checkout or calibration of parts and equipment may result in damage or possible malfunction of the equipment. This may also result in damage to property and injury including death. The purchaser and installer of these parts shall bear full responsibility and liability for the above.

All maintenance performed within the applicable warranty period (see warranty card) must be authorized in advance by Bird Products Corporation service representative in order to retain the warranty status of the subject unit.

WARRANTY

THE TBIRD VENTILATORY SYSTEMS ARE WARRANTED TO BE FREE FROM DEFECTS IN MATERIAL AND WORKMANSHIP AND TO MEET THE PUBLISHED SPECIFICATIONS FOR TWO (2) YEARS OR 8,000 HOURS, WHICHEVER OCCURS FIRST.

The liability of Bird under this warranty is limited to replacing, repairing or issuing credit, at the discretion of Bird, for parts that become defective or fail to meet published specifications during the warranty period; Bird will not be liable under this warranty unless (A) Bird is promptly notified in writing by Buyer upon discovery of defects or failure to meet published specifications; (B) the defective unit or part is returned to Bird, transportation charges prepaid by Buyer; (C) the defective unit or part is received by Bird for adjustment no later than four (4) weeks following the last day of the warranty period; and (D) Bird's examination of such unit or part shall disclose, to its satisfaction, that such defects or failures have not been caused by misuse, neglect, improper installation, unauthorized repair, alteration or accident.

Any authorization of Bird for repair or alteration by the Buyer must be in writing to prevent voiding the warranty. In no event shall Bird be liable to the Buyer for loss of profits, loss of use, consequential damage or damages of any kind based upon a claim for breach of warranty, other than the purchase price of any defective product covered hereunder.

Bird warranties as herein and above set forth shall not be enlarged, diminished or affected by, and no obligation or liability shall arise or grow out of the rendering of technical advice or service by Bird or its agents in connection with the Buyer's order of the products furnished hereunder.

LIMITATIONS OF LIABILITIES

This warranty does not cover normal maintenance such as cleaning, adjustment or lubrication and updating of equipment parts. This warranty shall be void and shall not apply if the equipment is used with accessories or parts not manufactured by Bird or authorized for use in writing by Bird, or if the equipment is not maintained in accordance with a prescribed schedule of maintenance.

The warranty stated above shall extend for a period of two (2) years from date of shipment or 8,000 hours of use, for those products employing an hour meter, whichever occurs first, with the following exceptions:

1. Components for monitoring of physical variables such as temperature, pressure, or flow are warranted for ninety (90) days from date of receipt.
2. Elastomeric components and other parts or components subject to deterioration, over which Bird has no control, are warranted for sixty (60) days from date of receipt.
3. Internal and Optional External batteries are warranted for ninety (90) days from the date of receipt.

THE FOREGOING IS IN LIEU OF ANY WARRANTY, EXPRESSED OR IMPLIED, INCLUDING, WITHOUT LIMITATION, ANY WARRANTY OF MERCHANTABILITY, EXCEPT AS TO TITLE, AND CAN BE AMENDED ONLY IN WRITING BY A DULY AUTHORIZED REPRESENTATIVE OF BIRD.



Copyright Notice

Copyright © 2000 by Bird Products Corporation, Palm Springs, California.

This work is protected under Title 17 of the US Code and is the sole property of Bird Products Corporation. No part of this document may be copied or otherwise reproduced, or stored in any electronic information retrieval system, except as specifically permitted under US copyright law, without the prior written consent of Bird Products Corporation. For more information, contact:

World Headquarters

Bird Products Corporation
1100 Bird Center Drive
Palm Springs, CA 92262-8099
U.S.A

Phone: (760) 778-7200

(800) 328-4139

Fax: (760) 778-7274

Trademark Notices

TBird is a trademark of Bird Products Corporation. All other brand names and product names mentioned in this manual are trademarks, registered trademarks, or trade names of their respective holders.



PLEASE
Read this entire manual before
attempting to service the ventilator.

Attempting to service the ventilator without fully understanding its features and functions may result in unsafe operating conditions.

Read the Safety Information section located immediately after the *About This Manual* chapter. It lists warnings, cautions, and notes pertinent to the safe servicing of the ventilator.

If you have a question regarding the installation, set up, operation, or maintenance of the ventilator, contact:

Customer Services

Hours: 7:00 AM to 3:30 PM (PST)
Monday through Friday
Phone: (760) 778-7200
(800) 328-4139
Fax: (760) 778-7274

Technical Services

Hours: 7:00 AM to 5:00 PM (PST)
Monday through Friday
Phone: (760) 778-7200
Fax: (760) 778-7274

BIRD Helpline

Hours: 24 hrs, seven days a week
Phone: (800) 934-BIRD
(800) 934-2473

World Headquarters

Bird Products Corporation
1100 Bird Center Drive
Palm Springs, CA 92262-8099
U.S.A.

Phone: (760) 778-7200

Fax: (760) 778-7274

European Office

Bird Products Corporation
Rembrandtlaan 1b, 3723 BG Bilthoven
P.O. Box 299, 3720 AG Bilthoven
The Netherlands

(31) 30 2289 711

(31) 30 2286 244



This page intentionally left blank.



CONTENTS AT A GLANCE

	About This Manual	xiii
	Safety Information	xvii
Chapter 1	Introduction	1-1
Chapter 2	Maintenance.....	2-1
Chapter 3	Service Verification Tests.....	3-1
Chapter 4	Technical Troubleshooting	4-1
Chapter 5	Removal And Replacement	5-1
Chapter 6	Schematics	6-1
Chapter 7	Parts List	7-1
	Appendix	
	Index	
	Bulletins	

.....

TABLE OF CONTENTS

About This Manual

Purpose	xiii
Intended Audience	xiii
Organization	xiv
Finding Information	xv
Conventions	xv
For More Information	xv

Safety Information

Terms	xvi
Symbols	xvi
Warnings	xvii
Cautions	xviii

Chapter 1 - Introduction

What This Chapter Describes	1-1
What You Need To Service The Ventilator	1-1
Required Training Or Authorization	1-1
Required Tools	1-1
Required Power And Oxygen Sources	1-2

Chapter 2 - Maintenance

What This Chapter Describes	2-1
Recommended Schedule Of Maintenance	2-1
500 Hours Maintenance	2-2
5,000 Hours Maintenance	2-2
20,000 Hours Maintenance	2-3

Chapter 3 - Service Verification Tests

What This Chapter Describes	3-1
Service Verification Tests (SVT) Overview	3-1
Performing The SVT	3-2
Solenoid Test	3-5
Calibration	3-6
Airway Pressure Transducer Calibration	3-7
Turbine Differential Pressure Calibration	3-8
Exhalation Differential Transducer Calibration	3-9
Oxygen Pressure Transducer Calibration	3-9
Turbine Serial Number Entry	3-10
Watch Dog Test	3-10



Chapter 4 - Technical Troubleshooting

Monitor Window Messages	4-1
Event Detection Codes	4-11
General Malfunctions.	4-13
Power Supply Voltage Check.	4-17

Chapter 5 - Removal And Replacement

What This Chapter Describes	5-1
Table of Contents	5-2
Ventilator Left and Right Side Cover Removal	5-3
Top Cover	5-5
Program Memory Card Removal & Configuration Memory Removal	5-6
Left or Right Protective Cover	5-8
Power Supply Removal	5-9
Internal Batteries	5-10
Energy Storage Capacitor	5-10
Motor Controller PCBA	5-12
Watch Dog PAL.	5-13
Panel Encoder Assembly	5-15
Main PCBA	5-15
Display PCBA	5-15
Front Panel.	5-15
Control Panel	5-15
Overlay.	5-15
Control Panel/Overlay.	5-15
7 Segment Red Display	5-17
Dot matrix Displays.	5-17
Socketed LED	5-17
7 Segment Yellow Display.	5-17
Muffler/Filter Core Assembly	5-18
Exhalation Valve	5-19
Turbine Assembly	5-20
Blender Assembly	5-21
Fan Assembly	5-22
Fan Inlet Filter	5-22
Fan EMI Filter	5-22
Patient Assist Call	5-23
Standby/On Switch	5-24
Fuse Holder	5-24
Alarm Loudness Potentiometer	5-24
EMI/RFI Filter	5-24



Turbine Differential Pressure Transducer . . .	5-25
Exhalation Differential Pressure Transducer	5-25
Base Plate O-Rings	5-26
Anti-Suffocation Valve	5-26
Outlet Check Valve Assembly	5-27
Relief Valve Assembly	5-27
External Docking Bay	5-28
Wire Harness And Cable Assemblies	5-34

Chapter 6 - Schematics

Wiring And Pneumatic Schematic	6-1
Block	6-2
Power Supply	6-17
Main PCBA	6-23
Display PCBA	6-36
Blender PCBA	6-40
External Battery Charger	6-41
Patient Assist Call	6-42

Chapter 7 - Parts List

What This Chapter Describes	7-1
Turbine/Muffler Assembly	7-2
Front Panel Assembly	7-3
Rear Panel Assembly	7-4
Oxygen Blending Components	7-5
Base Assembly	7-7
Right/Left Side Assembly	7-8
Top Cover Assembly	7-9
Wire Harness And Cable Assemblies	7-10
Main PCB Assembly	7-11
Power Supply PCB Assembly	7-12

- Appendix
- Index
- Bulletins

.....

List Of Figures

Figure	Description	Page
3-1	Main PCBA	3-2
3-2	Special Functions Group	3-3
3-3	SVT Diagram	3-5
3-4	Solenoid Test	3-6
3-5	Airway Pressure Transducer	3-7
4-1	Power Supply	4-17
5-1	Ventilator Left and Right Side Cover Removal	5-3
5-2	Top Cover Removal.	5-5
5-3	Program Memory Card and Configuration Memory Card	5-6
5-4	Protective Side Covers	5-8
5-5	Power Supply Removal	5-9
5-6	Internal Batteries/Energy Storage Capacitor	5-10
5-7	Motor Controller.	5-12
5-8	Main PCB, Watch Dog PAL.	5-13
5-9	Front Panel Disassembly	5-14
5-10	Front Panel Encoder Removal.	5-15
5-11	Displays	5-17
5-12	Muffler/Filter Core Assembly	5-18
5-13	Exhalation Valve	5-19
5-14	Turbine Assembly	5-20
5-15	Blender Assembly	5-21
5-16	Fan Assembly	5-22
5-17	Patient Assist Call	5-23
5-18	Turbine Differential Pressure Transducer and Exhalation Differential Transducer	5-25
5-19	Base Plate O-Rings and Anti-Suffocation Valve	5-26
5-20	Outlet Check Valve Assembly and Relief Valve Assembly	5-27
5-21	Ventilator Base.	6-28
5-22	Docking Bay Assembly	5-29
5-23	8 Position Connector.	5-30
5-24	Right Side Cover	5-31
5-25	Power Supply PCBA	5-32
7-1	Turbine/Mufler Assembly	7-2
7-2	Front Panel Assembly	7-3
7-3	Rear Panel Assembly	7-4



List Of Figures (Continued)

7-4	Oxygen Blending Components	7-5
7-5	Base Assembly	7-6
7-6	Right/Left Side Assembly	7-8
7-7	Top Cover Assembly	7-9
7-8	Wire Harnesses And Cable Assemblies	7-10
7-9	Main PCB Assembly	7-11
7-10	Power Supply PCB Assembly	7-12

List Of Tables

Table	Description	Page
I	Manual Organization	xiv
1-1	Required Tools	1-1
2-1	Recommended Schedule of Maintenance	2-1
2-2	5,000 Hour Replacement Components	2-2
2-3	20,000 Hour Replacement Components	2-4
5-1	Wiring Connections	5-34

ABOUT THIS MANUAL

Purpose

This manual shows you how to diagnose, service, and repair the TBird ventilator series. After reading this manual, you will understand:

- What the ventilator is and how it works.
- What regularly scheduled maintenance should be performed and when it should be performed.
- What tools and equipment are required to service the ventilator.
- What software tests are available in the ventilator to help you troubleshoot and calibrate the ventilator.
- How to remove and replace the critical components of the ventilator.
- How to completely disassemble and reassemble the ventilator.
- How to calibrate transducers and other internal components to make sure the ventilator is working properly.
- How to do a performance check.
- A complete set of schematics, an exploded view of the system, and an illustrated parts list is included.

Intended Audience

This manual is written for Bird Products trained and authorized service personnel. It assumes you are familiar with Bird Product ventilators and have attended the TBird ventilator series training class.



WARNING



If you are not authorized by Bird Products to work on the TBird ventilator series, do not attempt to perform any of the procedures described in this manual. If you ignore this warning, you may create conditions that could be harmful to the patient, as well as void the warranty. **DO NOT SERVICE THE VENTILATOR UNLESS YOU HAVE BEEN TRAINED AND AUTHORIZED BY BIRD PRODUCTS TO DO SO.**

Organization

This manual is organized as described in Table I.

Table I. Manual Organization

#	Title	Description
1	Introduction	Introduces the TBird ventilators and lists the tools and equipment you will need to service the ventilator.
2	Maintenance	Shows the recommended schedule of maintenance and gives procedures for performing scheduled maintenance after 500, 5,000 and 20,000 hours of operation.
3	Service Verification Tests	Shows you how to run the Service Verification Tests that are built into the ventilator's software. These tests help you troubleshoot the ventilator or verify that it is working properly.
4	Technical Troubleshooting	Shows you how to troubleshoot the ventilator when it doesn't power up properly, a vent inop condition exists, or otherwise doesn't appear to be functioning properly.
5	Removal and Replacement	Shows you how to remove and replace the major critical components of the ventilator.
6	Schematics	Contains a complete set of schematics.
7	Parts List	Contains an exploded view diagram of the ventilator and illustrations of each replaceable component or assembly.



Note

Refer to the TBird Operator's Manuals, Appendix A for a glossary of terms.



Finding Information

This manual is designed to help you to quickly locate information. It features:

- **Table Of Contents:** Take a minute to look over the Table of Contents. It shows the material covered and the order in which it is covered. This will help you locate information more easily.
- **Running Headers:** The chapter title and primary topic covered on each page is printed in the upper, outer corner of the page to help you locate information by thumbing through the manual.

Conventions

The following print conventions are used in this manual:

- All front panel controls are printed in bold as follows: **Breath Rate**, **Tidal Volume**, and **Sensitivity**.
- All messages displayed in the monitor window or alarm window are printed in the following font: NO AC POWER, HIGH PRES, and KP $nn.n$ cmH₂O.

For More Information

For more information contact Bird Products Customer Service or Technical Support organizations at:

World Headquarters

Bird Products Corporation

1100 Bird Center Drive
Palm Springs, CA 92262-8099

U.S.A

Phone: (760) 778-7200

(800) 328-4139

Fax: (760) 778-7274



This page intentionally left blank.

.....

SAFETY INFORMATION

Please review the following safety information prior to operating the ventilator.

TERMS

- WARNINGS** identify conditions or practices that could result in serious adverse reactions or potential safety hazards.
- CAUTIONS** identify conditions or practices that could result in damage to the ventilator or other equipment.
- NOTES** identify supplemental information to help you better understand how the ventilator works.

SYMBOLS



This symbol indicates a **WARNING**.



This symbol indicates a **CAUTION**.



This symbol indicates a **NOTE**.



WARNINGS



Refer to the TBird Operator's Manuals for operator safety information and warnings. The following warnings apply any time you are servicing the ventilator.

- If you are not authorized by Bird Products to work on the TBird ventilator series, do not attempt to perform any of the procedures described in this manual. If you ignore this warning, you may create conditions that could be harmful to the patient, as well as void the warranty. **DO NOT SERVICE THE VENTILATOR UNLESS YOU HAVE BEEN TRAINED AND AUTHORIZED BY BIRD PRODUCTS TO DO SO.**
- The Service Verification Tests (SVT) must never be performed when the ventilator is connected to a patient and therefore require specific and deliberate action on the part of the technician to enable them.
- The procedure for calibrating the Exhalation Differential Transducer requires the use of external pressure sources and external pressure monitoring. Do not select this test unless the required equipment is available. External values applied during these tests will change internally stored information in the ventilator. Performance and accuracy will be affected if external test equipment is not of the specified accuracy.
- Electrical shock hazards are present within the ventilator even after AC power has been removed. It is recommended that the top cover be electrically unplugged to disconnect the batteries from the ventilator.
- Electrical shock hazards are present within the ventilator even after AC power has been removed. Pay particular attention to the large electrolytic capacitor mounted to the top cover.



CAUTIONS



Refer to the TBird Operator's Manuals for operator safety information and cautions. The following cautions apply any time you are servicing the ventilator.

- Performing the 5,000 hour maintenance requires access to the interior of the ventilator. It is intended to be performed by a Bird Factory Trained technician. The technician should be familiar with appropriate ESD (Electro-Static Discharge) prevention techniques to avoid damage to electronic components.
- Double check the pneumatic connection to the T DIFF transducer before applying pressure. If the 60 cmH₂O pressure is inadvertently applied to the X DIFF transducer it will be permanently damaged and require replacement.
- Appropriate measures to prevent ESD damage to electronic components must be taken:
 - Wear a properly grounded and tested anti-static wrist strap when handling Printed Circuit Boards (PCBs).
 - Work on an anti-static surface.
 - Always use anti-static material for packaging PCB's.
 - Attached to the top cover of the ventilator is a large energy storage capacitor that may have some residual charge. Use extreme care not to allow any conductive material to contact the electrical connections.
- The Power Supply is mounted to the right side cover of the ventilator. Removal must be done carefully to ensure that wire harnesses are not strained and that the Power Supply components are not allowed to contact electrically conductive materials of the ventilator including the shield coating on the inside of the ventilator.
- When handling the Program Memory Card and contacting the inside of the ventilator, precautions must be taken to avoid ESD damage. An anti-static wrist strap should be worn and correctly grounded while performing this procedure. At a minimum, always touch the copper colored coating inside of the chassis to equalize potential charges prior to placing the card in the ventilator.
- Before assembling the ventilator, be sure to double check the alignment of connector J5. Misalignment of this connector can cause catastrophic damage to the Power Supply and/or the Main PCB.
- Prior to cover removal, disconnect AC power from the wall source and ensure that the Stand By/On Switch is in the Stand By Position.



This page intentionally left blank.

CHAPTER 1 INTRODUCTION

What This Chapter Describes

This chapter describes what you will need to service the ventilator series. Please refer to the TBird VS/VSO₂ Operator’s Manual (P/N L1310) and the TBird AVS Series Operator’s Manual (P/N L1331) for complete information on the operation of the TBird ventilator series.

What You Need To Service The Ventilator

To service the ventilator, you need the following:

- Training or authorization from Bird Products.
- Required tools as specified below.
- Power and oxygen sources.

Required Training Or Authorization

Only Bird certified and authorized service personnel are permitted to service the ventilator. If you are not certified or authorized, please do not attempt to perform any of the service procedures listed in this manual.

Required Tools

All components of the TBird ventilator can be removed and replaced using the tools listed Table 1-1. These tools can be acquired from your local hardware store or supplier. Bird Product’s does not sell these tools.

Table 1-1. Required Tools

Phillips Cross-tip screwdriver
Pliers
Needle Nose Pliers
Thin Walled 11/32-inch socket or nut driver
IC removal tools
Anti-static wrist strap
Common screwdriver

Required Power And Oxygen Sources

To operate the ventilator you need a power source and oxygen source:

- **Power Source.** The ventilator operates from a standard 100, 110, 220, or 240 VAC. power source, the internal battery, or an optional external 48 VDC Supply (4 x 12 VDC batteries). The ventilator comes factory equipped with a built-in battery, capable of providing power during short-term patient transports or AC power interruptions. The optional external battery can be used for longer term support.
- **Pressurized Oxygen.** The compressed oxygen source must provide clean, dry, medical grade oxygen at a line pressure of 40 to 60 PSIG (2.8 to 4.2 bar).
- **Low Pressure Oxygen (VS only).** The low flow oxygen source must provide clean, medical grade oxygen at flows of 0 to 80 lpm and a pressure not exceeding 0.5 PSIG (0.35) bar.

CHAPTER 2 – MAINTENANCE

What This Chapter Describes

This chapter describes the recommended maintenance to be performed on the ventilator after 500, 5,000, and 20,000 hours of operation. After reading this chapter you will understand:

- What scheduled maintenance is required and when it is required.
- How to perform the required maintenance.

Recommended Schedule of Maintenance

The TBird ventilator is designed to operate for long periods of time with very little maintenance. Table 2-1 gives a recommended schedule for maintaining the ventilator and describes the tasks that should be performed at each of the scheduled maintenance times.

Table 2-1. Recommended Schedule Of Maintenance

Schedule	Maintenance
Every 500 Hours	Clean the air intake and fan intake filters, replacing them if necessary. Check the exhalation valve body, O-rings and diaphragm, replacing them if necessary. Refer to the TBird Operator's Manual, Chapter 9, Cleaning & Sterilization.
Every 5000 Hours	Perform extended maintenance, replacing specific internal and external components. Check out the ventilator and calibrate as required.
Every 20,000 Hours	Perform a complete maintenance procedure, replacing components that are approaching the end of their useful life.

This schedule assumes the ventilator is operating in a typical clinical setting. Environmental conditions may necessitate more frequent maintenance.

500 Hour Maintenance

Every 500 hours, perform the following:

1. Clean the air intake and fan intake filters, replacing them if necessary.
2. Check the exhalation valve body, O-rings and diaphragm, and replace them if necessary. Refer to the TBird Operator's Manual, Chapter 9, Cleaning & Sterilization.

5,000 Hour Maintenance

After 5,000 hours of operation, extended maintenance is required. During this maintenance, several internal and external components need to be replaced. The ventilator also needs to be checked out and, if necessary, calibrated.

Table 2-2. 5,000 Hour Replacement Components

Part	P/N
Muffler Tube O-Rings	30020
Muffler/Filter Cores	10365
Rear Inlet Filter	20819
Fan Filter	33749

To perform the 5,000 hours maintenance, do the following:



CAUTION



Performing the 5,000 hour maintenance requires access to the interior of the ventilator. It is intended to be performed by a Bird Factory Trained technician. The technician should be familiar with appropriate ESD (Electro-Static Discharge) prevention techniques to avoid damage to electronic components.

1. Remove the left and right side panels from the ventilator as described in Chapter 5, Removal & Replacement.



2. Remove and replace the Muffler/Filter Cores and O-Rings as described in Chapter 5, Removal & Replacement.

 **Note**

If the inlet filter to the turbine is found to be excessively dirty, the interval between replacement of the internal filter should be reduced to prevent malfunction or damage to the ventilator.

3. Reassemble the ventilator but do not install the left side panel so that the SVT may be performed later in this procedure.
4. Check the exhalation valve body, O-rings and diaphragm, and replace them if necessary. Refer to the TBird Operator's Manual, Chapter 9, Cleaning & Sterilization.
5. Replace the Fan Filter and the Air Inlet Filter. Refer to the TBird Operator's Manuals.
6. Perform the UVT as described in the TBird Operator's Manual and the SVT as described in this manual.
7. Ensure that DIP switch 1 is in the OFF position.
8. Reassemble the left side panel.
9. Perform the operational check as described in the TBird Operator's Manuals.

20,000 Hour Maintenance

After 20,000 hours of operation, the assemblies listed in Table 2-3 will require replacement. Refer to Chapter 5, Removal and Replacement for detailed instructions.

Prior to disassembly, the ventilator should be inspected for any external damage requiring additional replacement. Particular attention should be paid to the following:

- External hardware of the ventilator
- The Power Cord
- The Control Panel and Overlay

Any of these items that need replacement will have to be ordered in addition to the parts specified below.

As the ventilator is being disassembled, the interior of the ventilator should be inspected for the following:

- Accumulation of dust or lint
- Appearance of liquid entry into the ventilator
- Damage to electrical wiring by chafing or pinching
- Secure electrical connection
- Damage to tubing by chafing or kinking

If any of these conditions are found to be present, appropriate cleaning and replacement should be accomplished before proceeding or the unit should be returned to Bird Products for more extensive repair.

Table 2-3. 20,000 Hour Replacement Components

Part	P/N
Turbine	15430A
Muffler Tube O-Rings	30020
Turbine Base Gasket	20754
Manifold Base O-Rings	04358, 30018, 30023
Anti-Suffocation Valve	20651
Pressure Relief Valve O-Rings	30017, 30005
Outlet Check Valve and O-Rings	05625, 30005,30019
Exhalation Valve	15429
Muffler/Filter Cores	10365
Internal Batteries (4)	20811
Blender Assembly (VSO ₂ /AVS)	15433A
Fan	15500
Rear Inlet Filter	20819
Fan Filter	33749
O ₂ Bleed Tube	20927
O ₂ Inlet Hose	00666

After performing the 20,000 Hour Maintenance, the following procedures must be performed to help ensure that the ventilator is prepared to be returned to service.

Follow the instructions in the SVT section of this manual to perform the calibrations of the:

- a. Turbine Differential Transducer
 - b. Exhalation Differential Transducer
 - c. Airway Pressure Transducer
 - d. Oxygen Pressure Transducer (VSO₂/AVS).
1. Perform Transducer tests and the UVT as described in the TBird Operator's Manuals. This may indicate the presence of leaks which must be corrected prior to proceeding.
 2. Perform the operational check as described in the TBird Operator's Manuals.



This page intentionally left blank.

CHAPTER 3 – SERVICE VERIFICATION TESTS

What This Chapter Describes

The Special Functions programmed into the TBird Ventilator Series allow the operator to obtain information, change parameters, and perform calibrations that are not available during normal operation. Included are the following functions:

- Configure the ventilator
- Monitor pressure transducer operation
- Check the hour meter, software revisions, and event code history
- Test the visual displays, control panel, filters, and perform leak testing
- Manually control internal ventilator functions
- Calibrate the pressure transducers

Service Verification Tests (SVT) Overview



WARNING



The Service Verification Tests (SVT) must never be performed when the ventilator is connected to a patient and therefore require specific and deliberate action on the part of the technician to enable them.

The SVT incorporates all the features of the Special Functions and UVT capabilities as explained in the TBird Operator's Manual (P/N L1331) and adds the following features:

1. Manual Turbine Control. The Turbine can be controlled in terms of:
 - a) RPM
 - b) Flow
 - c) Pressure
2. Manual Oxygen Percentage Control
3. Manual Solenoid Control:
 - a) Auto Zero solenoids
 - b) Oxygen Blender solenoids
 - c) Inspiratory Hold Solenoid

- 4. Transducer Calibration:
 - a) Turbine Differential Pressure Transducer
 - b) Exhalation Differential Pressure Transducer
 - c) Airway Pressure Transducer
 - d) Oxygen Blender Pressure Transducer
- 5. Entry of turbine serial number:
 - a) Ensures that the proper turbine characterization information is being utilized for accurate delivery of pressure and flow.
- 6. Watch Dog Test:
 - a) This function forces a software malfunction and tests to see if it is properly handled.

These abilities allow simulation of a wide variety of situations and with the monitoring of transducer information can be a valuable troubleshooting tool.

Performing The SVT

To perform the SVT, you must access the inside of the ventilator. This is intended for use by a Bird Factory Trained technician. Additionally, it requires the use of test equipment whose accuracy is known and that have been recently calibrated. If the test equipment is not available, the unit should be returned to Bird Products for proper calibration.

- 1. Place the On/Standby switch to the Standby position. Refer to the Removal and Replacement section of this manual for removal of the sides and top of the ventilator.
- 2. Locate DIP Switch 1 on the Main PCBA.

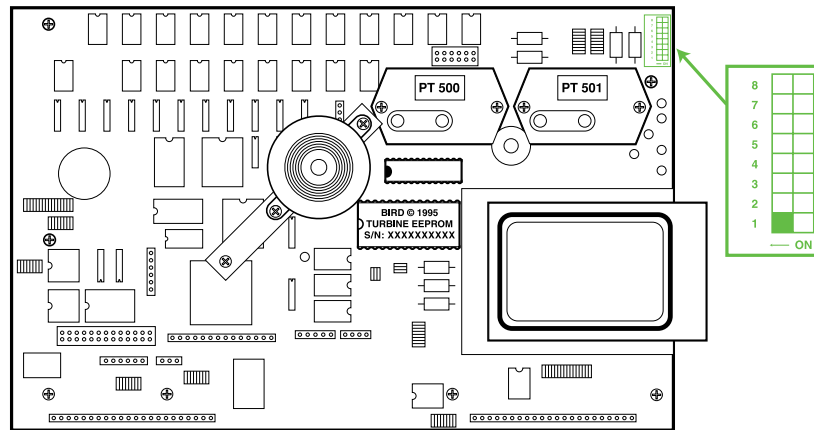

Figure 3-1. Main PCBA

3. Place DIP Switch 1 in the ON position. This is towards the inside of the ventilator as shown in Figure 3-1.
4. Turn the ventilator ON.

After the ventilator completes the Power On Self Test, the **Monitor Window** will display SVT ON.

 **Note**

When the SVT is entered, the audible alarm will be automatically enabled to alert the operator that this mode is being activated. Alarm Silence must be pressed to cancel the alarm.

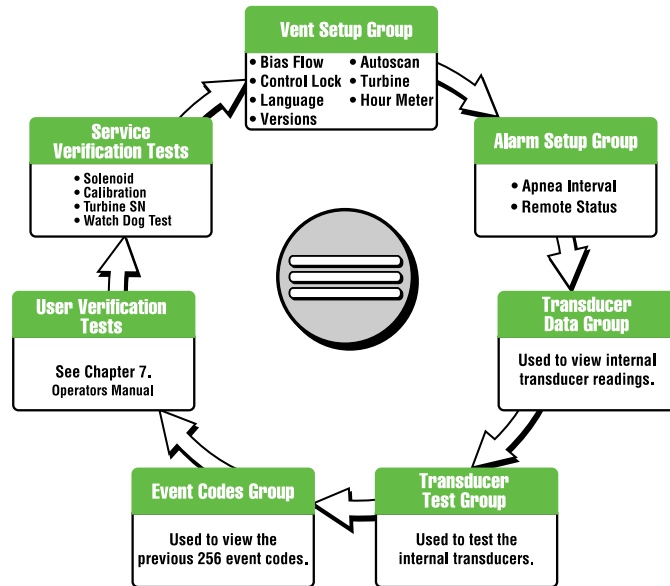

Figure 3-2. Special Functions Groups

As shown in Figure 3-2, all of the basic features of special functions and UVT are available. Rotating the *Set Value Knob* will display the available options in the **Monitor Window**:

SVT ON
VENT SETUP
ALARM SETUP
XDCR DATA
XDCR TESTS
EVENTS
UVT ON

While the ventilator is in the SVT mode, three or four control panel displays will be illuminated depending on the unit model.

The Tidal Volume display represents the RPM of the turbine. It may be changed by first pressing the button below the display and rotating the *Set Value Knob*.

The Peak Flow display represents the output of the turbine in LPM. This may be adjusted in the same way as the RPM.

The PEEP/CPAP window represents the pressure in the patient circuit and is developed by the control of the Exhalation Valve. This may be adjusted in the same way as the RPM. However, to see any pressure developed in the patient circuit, some flow value or turbine speed must be entered first.

With the VSO₂/AVS, the Oxygen Percentage window will be illuminated. Oxygen percentage may be set at any time some flow value and turbine speed has been activated.

While the turbine speed, turbine flow, or circuit pressure are being manually controlled, the pressure transducers may be monitored by selecting XDCR DATA and selecting the appropriate transducer. This may be useful in determining if there is a malfunction of the unit. Refer to the troubleshooting section of this manual for further information.

5. Rotate the *Set Value Knob* until SVT ON is displayed in the **Monitor Window**.

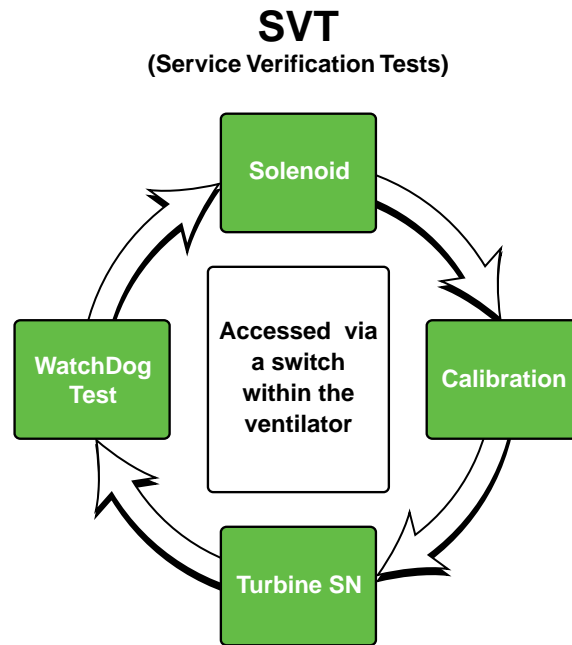

Note: During the SVT, Tidal Volume controls turbine RPM, Peak Flow controls turbine flow, PEEP/CPAP controls circuit pressure, and %O₂ controls the blender.

Figure 3-3. SVT (Service Verification Test)

Figure 3-3 shows the tests available when SVT is accessed within the special functions. Rotating the set value knob will display the available options in the monitor window.

Solenoid Test

1. Press the *Select Key*. The **Monitor Window** will display SOLENOID.
2. Press the *Select Key*.

Rotating the *Set Value Knob* will display the solenoids by name in the **Monitor Window**. When the *Select Key* is pressed, the solenoid selected will toggle between OFF (inactive) and ON (activated). Refer to Figure 3-4 for the solenoid being tested.

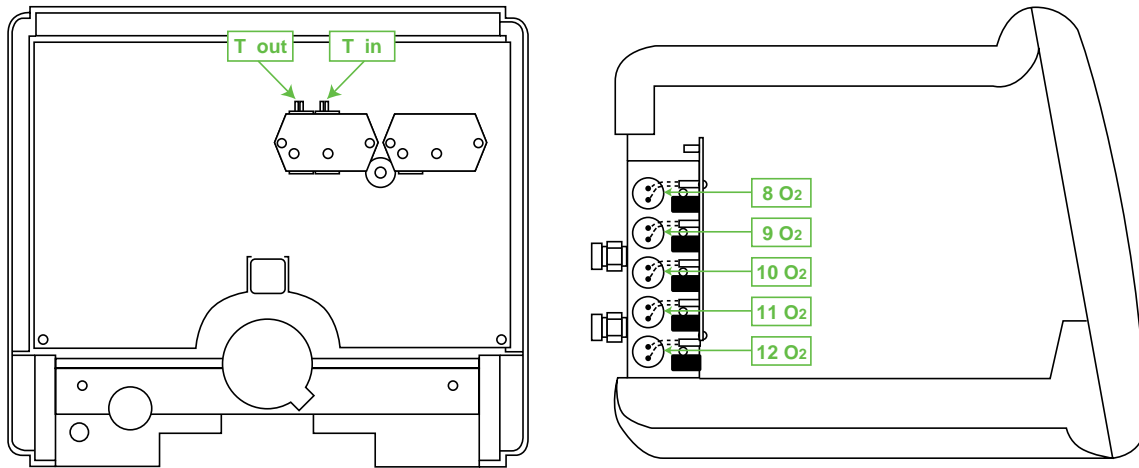

Figure 3-4. Solenoid Test

0 OCC OFF	Inspiratory Hold Valve (AVS only)
4 T OUT OFF	Turbine Outlet Auto Zero Solenoid
5 T IN OFF	Turbine Inlet Auto Zero Solenoid
6 XPRES OFF	Airway Pressure Auto Zero Solenoid
8 O2 OFF	Blender Solenoid, TBird™ VSO₂ and AVS
9 O2 OFF	Blender Solenoid, TBird™ VSO₂ and AVS
10 O2 OFF	Blender Solenoid, TBird™ VSO₂ and AVS
11 O2 OFF	Blender Solenoid, TBird™ VSO₂ and AVS
12 O2 OFF	Blender Solenoid, TBird™ VSO₂ and AVS
13 O2 OFF	Not Used

3. Press the *Set Value Knob* to display SOLENOID in the Monitor Window.

Calibration

Rotate the *Set Value Knob* until Monitor Window displays CALIBRATION.

Note

If you enter calibration within the first 60 seconds of ventilator operation, a waiting message will be posted. Once the waiting message clears, you may proceed with calibration.



WARNING



The procedure for calibrating the Exhalation Differential Transducer requires the use of external pressure sources and external pressure monitoring. Do not select this test unless the required equipment is available. External values applied during these tests will change internally stored information in the ventilator. Performance and accuracy will be affected if external test equipment is not of the specified accuracy.

 **Note**

During the calibration process, the manual control of the Turbine and Blender will be inhibited. This is indicated by the display of **OFF** in their display windows.

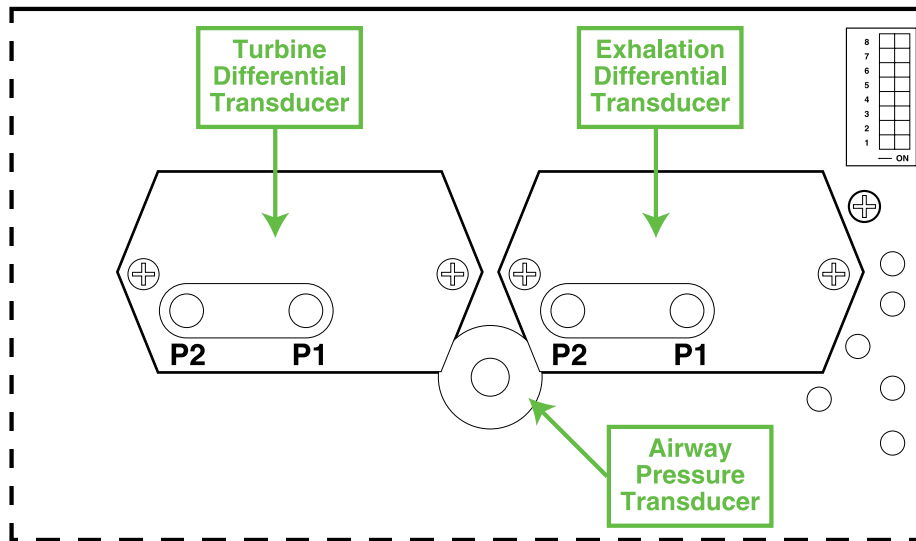

Figure 3-5. Airway Pressure Transducer

Airway Pressure Transducer Calibration

1. Press the *Select Key*. The Monitor Window will display \times PRES.

Referring to Figure 3-5, disconnect the tubing from the Airway Pressure Transducer.

2. Press the *Select Key* and the **Monitor Window** will display `XPRES 0`.
3. Press the *Select Key* to enter this value to ventilator memory and to advance the monitor display to read `XPRES 60`.
4. Connect an external source of 60 ± 0.6 cmH₂O to the Airway Pressure Transducer.
5. Press the *Select Key* to enter this value to ventilator memory.

If the values are within tolerance, the **Monitor Window** will display `XCAL OK`.

If the monitor display reads `XCAL NOT OK`, repeat the calibration with attention to the applied pressure.

To store the new calibration values in memory, press the *Select Key*. To ignore the new value, press the *Set Value Knob*.

Referring to Figure 3-5, replace the original tubing to the Airway Pressure Transducer.

Turbine Differential Pressure Calibration

1. Press the *Select Key* and the **Monitor Window** will display `TDIFF`.

Referring to Figure 3-5, remove the two (2) tubes from the Turbine Differential Transducer.

2. Press the *Select Key* and the **Monitor Window** will display `TDIFF 0`.
3. Press the *Select Key* to enter this value to ventilator memory and to advance the Monitor Display to read `TDIFF 60`.



CAUTION



Double check the pneumatic connection to the TDIFF transducer before applying pressure. If the 60 cmH₂O pressure is inadvertently applied to the X DIFF transducer it will be permanently damaged and require replacement.

Referring to Figure 3-5, connect an external source of 60 ± 0.6 cmH₂O to the P2 port on the Turbine Differential Transducer.

To store the new calibration values in memory, press the *Select Key*. To ignore the new value, press the *Set Value Knob*.

If the values are within tolerance, the **Monitor Window** will display TCAL OK.

If the Monitor Display reads TCAL NOT OK, repeat the calibration with attention to the applied pressure.

4. Replace the original tubing to the Turbine Differential Transducer.

Exhalation Differential Transducer Calibration

1. Press the *Select Key* and the **Monitor Window** will display XDIFF.

Referring to Figure 3-5, remove the two (2) tubes from the Exhalation Differential Transducer.

2. Press the *Select Key* and the **Monitor Window** will display XDIFF 0.
3. Press the *Select Key* to enter this value to ventilator memory and to advance the Monitor Display to read XDIFF 3.
4. Connect an external source of 3 ± 0.03 cmH₂O to the P2 port on the Turbine Differential Transducer.
5. To store the new calibration values in memory, press the *Select Key*. To ignore the new value, press the *Set Value Knob*.

If the values are within tolerance, the **Monitor Window** will display FCAL OK.

If the **Monitor Window** reads FCAL NOT OK, repeat the calibration with attention to the applied pressure.

6. Replace the original tubing to the Exhalation Differential Transducer.

Oxygen Pressure Transducer Calibration

1. Press the *Select Key* and the **Monitor Window** will display O2 CAL.

2. If oxygen is connected to the unit, turn off the pressure and disconnect it from the ventilator. Using a small screwdriver or similar tool, momentarily open the check valve in the O₂ inlet fitting to insure that any residual pressure is released.
3. Press the *Select Key* and the **Monitor Window** will read 02 0.
4. Press the *Select Key* to store the 0 pressure point in memory.
The **Monitor Window** will now read 02 50.
5. Attach a known 50 ± 0.1 psi source to one of the O₂ fittings at the rear of the ventilator.
6. Press the *Select Key* to store the 50 psi pressure point in memory.

Turbine Serial Number Entry

1. Press the *Select Key* and the **Monitor Window** will display TURBINE SN.



Note

Prior to performing the following procedure, record the serial number from the EEPROM supplied with the Turbine and the serial number from the label on the turbine.

2. Press the *Select Key* and the **Monitor Window** will be blanked. The serial number from the Turbine may now be entered by turning the *Set Value Knob* to the value desired. When the first digit is displayed, press the *Select Key* to advance to the second digit. Upon entry of the last digit, the unit will exit the entry mode.

Watch Dog Test

1. Rotate the *Set Value Knob* and the **Monitor Window** will display WDOG TEST.



Note

The Watch Dog test simulates an actual event that would take place if a malfunction of the microcomputer system had occurred. **Consequently the results of this test will force the ventilator into a VENT INOP state.** The only way to recover from this is to turn the ventilator off and back on again.

2. Press the *Select Key*.

The unit will go into an INOP state, all displays will be blank, the Vent Inop LED will be illuminated, and a steady audible tone will be generated.

3. Place the **On/Standby** switch in the Standby position and press the **Alarm Silence** key to silence the audible alarm.

To repeat any of the Special Functions, place the unit in the On position. If you are finished, restore DIP switch 1 to the off position and replace the covers on the unit.



This page intentionally left blank.

CHAPTER 4 — TECHNICAL TROUBLESHOOTING

Monitor Window Messages

This section of the service manual provides symptoms, definitions, and suggestions for the correction of problems that may be reported with the TBird Ventilator.

In all cases, the technician should first ensure that the ventilator is being used properly to eliminate any possible operator related problems.

When a problem is reported, all available information should be obtained as to ventilator settings, the type of patient circuit being used, the patients condition, and the details of the reported malfunction.

If the ventilator has been recently serviced, particularly if the covers have been removed for any reason, check all electrical and pneumatic connections for proper installation and orientation. Often a marginal connection may not show up immediately.

The first series of messages are those that the ventilator may display in the Monitor Window as a result of initial Power On Self Tests or those messages that are generated as a result of continuous monitoring while the ventilator is in operation.

Display	Page	Display	Page
APNEA	4-2	IOP RAM	4-7
BATTERY ON	4-2	IOP ROM	4-7
CHECK BKUP	4-2	IOP TIMER	4-7
CHECK EVENTS	4-2	IOP XRAM	4-7
CIRC FAULT	4-3	LIMITED	4-7
DEFAULTS	4-3	LOCKED	4-8
DPRAM 1	4-3	LOW BATTERY	4-8
DPRAM 2	4-3	LOW O ₂	4-8
EEPROM FAULT	4-3	LOW PRES	4-8
EXT BATTERY	4-3	LOW VOLUME	4-9
FAN FAULT	4-4	NEW SENSOR	4-9
FILTER	4-4	NO CAL DATA	4-9
FLASH UPDATE	4-4	POWER UP	4-9
FLOW CAL	4-5	RELEASE IOP	4-9
FLOW SENSOR	4-5	REMOTE FAULT	4-9
HIGH O ₂	4-6	ROM 1	4-9
HIGH PEEP	4-6	SRAM	4-10
HIGH PRES	4-6	TIMER	4-10
HW FAULT	4-7	TURBINE ROM	4-10
IOP CPU	4-7	WATCHDOG PAL	4-10
IOP DPRAM	4-7	XDCR FAULT	4-10
IOP IRAM	4-7		

**TECHNICAL TROUBLESHOOTING
MONITOR WINDOW MESSAGES**

Monitor Window	Description	Suggestion
APNEA	Time between detected inspirations has exceeded the set Apnea Interval.	<ol style="list-style-type: none"> 1. Evaluate patient status. 2. Verify that Apnea Interval is at appropriate setting. 3. Verify Sensitivity setting. 4. Perform Auto-Zero on Transducers. 5. Check/replace Flow Transducer.
BATTERY ON	<p>Operating on Battery Power (Internal or External Battery). This will occur if:</p> <ul style="list-style-type: none"> • AC power has been lost from the ventilator. • Internal wiring has become disconnected. • A power supply malfunction is simulating an AC loss. 	<ol style="list-style-type: none"> 1. Check power cord for secure connections. 2. Check fuse(s). 3. Check wall AC receptacle. 4. Check all internal connections associated with AC. (See Chapter 6, Schematics, of this manual.) 5. Replace power supply with a known functional unit.
CHECK BKUP	Ventilator has powered up in CPAP Mode or CPAP Mode is selected.	<ol style="list-style-type: none"> 1. Verify that Apnea Back Up ventilation parameters are appropriately set.
CHECK EVENTS	Errors have been detected forcing a machine reset. This is a prompt to investigate which events caused this to occur.	<ol style="list-style-type: none"> 1. Check the definition of the stored event codes as described in Appendix G of the TBird Operator's manuals and perform suggested remedies. 2. Contact Bird Certified Service Technician.

Monitor Window	Description	Suggestion
CIRC FAULT	<p>This may be caused by one of the following circumstances:</p> <ol style="list-style-type: none"> 1. The turbine differential pressure has exceeded the High Pressure Limit setting by an excessive amount. 2. A flow rate of 150 LPM has persisted for > 2 seconds. 3. A problem exists with one of the internal transducers. 	<ol style="list-style-type: none"> 1. Check for occlusions of the patient circuit. 2. Check the pressure transducers for possible drift. 1. Check for a disconnect in the patient circuit. 2. Check the pressure transducers for possible drift. 1. Check the transducer for possible drift.
DEFAULTS	<p>This will occur as an intended operation when the program memory or configuration memory cards are installed.</p> <p>It may also occur when ventilator parameters have reverted to internally stored values. EEPROM memory has been corrupted or is no longer functional.</p>	<ol style="list-style-type: none"> 1. Enter desired ventilator parameters. 1. Enter desired ventilator parameters. 2. Replace Main PCBA.
DPRAM 1	<p>POST detected a failure of the Dual Port Random Access Memory.</p>	<ol style="list-style-type: none"> 1. Replace Main PCB.
DPRAM 2	<p>POST detected a failure of the Dual Port Random Access Memory. Data read does not match data written.</p>	<ol style="list-style-type: none"> 1. Replace Main PCB.
EEPROM FAULT (Alert)	<p>EEPROM that stores ventilator settings will not accept additional information.</p>	<ol style="list-style-type: none"> 1. Replace Main PCBA.
EXT BATTERY	<p>Battery power has switched from the optional external battery to the internal battery.</p>	<ol style="list-style-type: none"> 1. Check that the external battery is connected securely. 2. Replace external battery with one which has been recently fully charged. 3. Connect the unit to AC power.

**TECHNICAL TROUBLESHOOTING
MONITOR WINDOW MESSAGES**

Monitor Window	Description	Suggestion
FAN FAULT	<p>Continuous ventilator status monitoring has detected that the cooling fan has stopped or is rotating at an unacceptably low rate of speed.</p>	<ol style="list-style-type: none"> 1. Check to see that there is nothing preventing or interfering with the fan's rotation. 2. Check the electrical connection from the fan to the Power Supply PCBA. 3. Replace the fan assembly.
FILTER (Alert)	<p>This alert appears when the ventilator hour meter is on even multiples of 500 as a reminder to check the inlet filters on the ventilator.</p>	<ol style="list-style-type: none"> 1. Clean or replace air inlet filter. 2. Pressing SELECT will clear this alert. However, if the ventilator is placed in standby and turned back on while the hour meter is still a multiple of 500, it will reappear.
FLASH UPDATE	<p>This is a normal message that is displayed when software changes are installed.</p> <p>It may also result if a comparison of the Configuration Memory Card and the IOP Flash Memory finds differences. An update will be attempted and if a difference is found again, the unit will be forced into an INOP state.</p>	<ol style="list-style-type: none"> 1. Replace Configuration Memory Card. 2. Replace Main PCB.

Monitor Window	Description	Suggestion
FLOW CAL (Alert)	<p>Internal or external leaks may be preventing a valid Flow Cal.</p> <p>Pressure Transducers may be out of calibration.</p>	<ol style="list-style-type: none"> 1. Perform a Manual Flow Cal Indicates a valid Flow Calibration has not been performed. This alert occurs when the Ventilator is Powered up. 1. Check for leaks in the patient circuit. 2. Check internal tubing to the Exhalation Pressure Transducer. 1. Perform Pressure Transducer calibrations as described in the SVT chapter of this manual.
FLOW SENSOR (Alert) (TBird AVS only)	<p>Ventilator cannot detect the presence of an AVS Exhalation Valve Body.</p> <p>TIRIS module is not operating correctly.</p>	<ol style="list-style-type: none"> 1. Verify that Exhalation Valve is correctly labeled as an AVS Valve Body. Installing a VS/VSO2 Valve body will cause this alert. 2. Reseat Exhalation Valve Body. 3. Replace Exhalation Valve Body 1. Contact Bird Certified Service Technician.

**TECHNICAL TROUBLESHOOTING
MONITOR WINDOW MESSAGES**

Monitor Window	Description	Suggestion
HIGH O ₂ (TBird AVS and VSO ₂ only)	Oxygen inlet pressure has risen above 65 psi. (This only occurs when FIO ₂ is set above 21% or 100% O ₂ 3 Min has been activated.)	<ol style="list-style-type: none"> 1. Reduce O₂ supply pressure below 65 psi. 2. Check calibration of O₂ Pressure Transducers described in the SVT chapter of this manual. 3. Replace Blender PCB.
HIGH PEEP	Pressure in the patient circuit is not returning to within +15 cmH ₂ O of the PEEP setting after an inspiration.	<ol style="list-style-type: none"> 1. Check patient circuit for occlusion in the expiratory leg. 2. Check exhalation manifold for proper assembly and patency of the exhalation diaphragm. 3. Check transducer calibration. 4. Replace exhalation valve body. 5. Replace exhalation valve.
HIGH PRES	The ventilator has attempted to exceed the High Pressure Alarm Setting.	<ol style="list-style-type: none"> 1. Evaluate patient status. 2. Evaluate setting of High Pressure Alarm. 3. Check for conditions with the patient circuit which may have decreased compliance. 4. Verify that front panel settings have not been changed. 5. Perform transducer calibration procedures as described in the SVT chapter of this manual.

Monitor Window	Description	Suggestion
HW FAULT	<p>This indicates that continuous monitoring has detected a Hardware Fault. This indicates one of two conditions:</p> <ol style="list-style-type: none"> 1. A DAC on the Main PCB has failed its self test. The Event Code 250 will be stored. 2. An over temperature condition has been detected on the Power Supply. The Event Code 251 will be stored. 	<ol style="list-style-type: none"> 1. Remove the ventilator from its current location and attempt operation in a different environment to eliminate external causitive factors. If the problem persists, the Main PCBA is suspected to be malfunctioning. 1. Check that the fan filter is not occluded and that the fan is operating. 2. Check that the thermistor attached to the Power Supply has not been damaged. 3. Replace the Power Supply.
IOP CPU IOP TIMER & IOP RAM	<p>POST detected that the IOP programmed operation, timers, or internal RAM has failed.</p>	<ol style="list-style-type: none"> 1. Replace Main PCB.
IOP DPRAM	<p>During POST the IOP has found that it cannot correctly access DPRAM.</p>	<ol style="list-style-type: none"> 1. Replace Main PCB.
IOP ROM	<p>During POST the IOP program memory was found to be different from flash memory. Checksum test failed.</p>	<ol style="list-style-type: none"> 1. Replace Main PCB.
IOP XRAM	<p>During POST an error has been detected in the testing of the extended memory area used by the IOP (AVS only).</p>	<ol style="list-style-type: none"> 1. Replace the Main PCBA.
LIMITED (Alert)	<p>Operator is attempting to set ventilator controls that conflict with each other.</p>	<ol style="list-style-type: none"> 1. Evaluate the settings of the control being changed with relation to the ones that are flashing.

**TECHNICAL TROUBLESHOOTING
MONITOR WINDOW MESSAGES**

Monitor Window	Description	Suggestion
LOCKED (Alert)	Operator has attempted to change a control setting while the ventilator has Control Locks on.	<ol style="list-style-type: none"> 1. Press the Set Value Knob to release the locking function. 2. Change Control Locks status in the Special Functions.
LOW BATTERY	<p>Power remaining in the internal battery has dropped to medium capacity. This is accompanied by an intermittent audible alert and may be reset.</p> <p>OR:</p> <p>Power remaining in the internal battery has dropped to low capacity. This is accompanied by a continuous audible alarm and cannot be reset.</p>	<ol style="list-style-type: none"> 1. Connect ventilator to a source of AC power. 2. Connect ventilator to an external battery. 3. Remove unit from service until internal batteries can be checked or replaced. 4. Check wiring from the internal batteries to the Power Supply for secure connection.
LOW O ₂ (TBird AVS and VSO ₂ only)	Oxygen inlet pressure has fallen below 35 psi. (This only occurs when FIO ₂ is set above 21% or 100% O ₂ 3 Min has been activated.)	<ol style="list-style-type: none"> 1. Increase O₂ supply pressure to above 35 psi. 2. Check calibration of O₂ Pressure Transducer. 3. Replace Blender PCB.
LOW PRES	The ventilator has failed to exceed the setting of the Low Peak Pressure alarm.	<ol style="list-style-type: none"> 1. Evaluate patient status. 2. Check patient circuit and exhalation valve body for leaks. 3. Evaluate the setting of the Low Peak Pressure alarm. 4. Verify that front panel settings have not been changed. 5. Perform transducer calibration procedures as described in the SVT chapter of this manual.

Monitor Window	Description	Suggestion
LOW VOLUME	Measured exhaled volumes have fallen below the Low Minute Volume setting.	<ol style="list-style-type: none"> 1. Evaluate patient status. 2. Verify that the front panel settings have not been changed. 3. Check for leaks in the patient circuit and exhalation valve body. 4. Verify the delivered volumes as shown in the procedure at the end of this chapter.
NEW SENSOR (Alert) (T-Bird AVS only)	New AVS Exhalation Valve Body has been detected.	<ol style="list-style-type: none"> 1. This is a normal function when a new valve is detected. If alert persists for more than one minute, treat the same as the Flow Sensor Alert.
NO CAL DATA (Alert)	Stored transducer calibration data does not match validation code stored in EEPROM.	<ol style="list-style-type: none"> 1. Perform transducer calibration procedures as described in the SVT chapter of this manual. 2. Replace Main PCB.
POWER UP	POST detected a malfunction in the MSP.	<ol style="list-style-type: none"> 1. Verify proper software installation. 2. Replace software. 3. Replace Main PCB.
RELEASE IOP	During POST the IOP has failed to initiate program instructions after being allowed to do so.	<ol style="list-style-type: none"> 1. Replace Main PCB.
REMOTE FAULT	<p>Malfunction of the Remote Alarm PCB.</p> <p>Information from internal remote alarm module is absent or invalid. (Remote alarm must be enabled.)</p>	<ol style="list-style-type: none"> 1. Replace the Remote Alarm PCB. 1. Check internal cable for proper connection. 2. Replace the Remote Alarm PCB.
ROM 1	<p>During POST an error has been detected in the MSP Program Memory (configuration memory card). CRC check failed.</p>	<ol style="list-style-type: none"> 1. Replace the Program Memory Card with one known to be functional. 2. Replace Main PCB.

**TECHNICAL TROUBLESHOOTING
MONITOR WINDOW MESSAGES**

Monitor Window	Description	Suggestion
SRAM	POST has detected a failure in the Static Random Access Memory.	1. Replace Main PCB.
TIMER	POST has detected a failure in the hardware timers that generate interrupts for the MSP.	1. Replace Main PCB.
TURBINE ROM	An error has been detected in the calibration data memory of the turbine EEPROM. Checksum test failed.	1. Replace Turbine and Turbine EEPROM.
WATCHDOG PAL	POST has detected a failure in the Watch Dog circuitry.	1. Replace Main PCB.
XDCR FAULT	A manual or automatic auto-zero of a transducer has been performed and it is outside of defined limits or a transducer has drifted in output.	<ol style="list-style-type: none"> 1. Determine which transducer is suspect by checking XDCR DATA or XDCR tests per the UVT section in the TBird Operator's Manuals. 2. Check exhalation flow sensor for occluded passages. 3. Check seals on exhalation flow sensor for damage. 4. Check the internal tubing to the pressure transducers and Auto Zero solenoids for occlusion or disconnects. 5. Perform transducer calibrations as described in the SVT section of this manual. 6. Replace either the Turbine differential transducer or the Exhalation differential pressure transducer as indicated by the XDCR DATA. 7. If the XDCR DATA indicates the patient circuit pressure transducer is malfunctioning, the Main PCBA must be replaced.

Event Detection Codes

The Event Codes are software routines that are constantly monitoring the operation of the ventilator. If these routines detect an anomalous condition or result of some function, this code records that occurrence to assist in determining what occurred and when it occurred.

Individual occurrences of events may not be significant as they can be generated by external influences and may not affect the operation of the ventilator. Repetitive occurrences may indicate the need for investigation of the problem.

There are 4 general causes for these codes to be generated:

- **System Monitoring**

There are some codes which do not indicate a problem has occurred but reflect changes in ventilator status. These codes are meant to indicate points in time that may be useful in determining a problem should it happen after one of these events. Examples of these are:

- 64 - Ventilator has powered up
- 67 - Ventilator has switched from AC to battery power
- 68 - External battery alert occurred
- 69 - Internal battery alert occurred

- **Environmental**

Environmental conditions are external to the ventilator and exceed established standards. In some cases these may influence the operation of the ventilator. Examples of these include:

- EMI (Electro-Magnetic Interference)
- RFI (Radio Frequency Interference)
- ESD (Electro-Static Discharge)
- AC electrical supplies
- Temperature
- Inadequate or erratic oxygen supplies (VSO₂/AVS only)

Environmental conditions are the easiest to eliminate and do not require the intervention of a biomedical technician. The course of action would be to move the ventilator a distance from the location where the problem occurred, use a different AC outlet, or use a different source of oxygen. If the problem is eliminated there is a good possibility that there was some external factor involved.

- **Hardware**

A hardware condition would be a mechanical or electronic problem internal to the ventilator. Examples include:

- Loose or improperly positioned electrical connections
- Leaks or misplacement of internal pneumatic connections
- Malfunctioning pneumatic or electronic components within the ventilator

These would require more in-depth investigation and the assistance of a Bird Factory Trained technician.

- **Software**

Due to the extensive processes in the creation, validation, and testing of software, and the continuous self checking that the ventilator performs, this type of situation is the least likely to be the basis of a problem. The previously discussed causes must be eliminated prior to pursuing a problem with the software used in the ventilator.

If a software problem is suspected, it must be reported to Bird Products Corporation along with all of the circumstances of the occurrence. This will enable a Bird technician to evaluate the situation and suggest possible corrective action.

Refer to Appendix G of the TBird Operator's Manuals for an explanatory list of event codes.

General Malfunctions

The following table is concerned with General Malfunctions. In all cases, first be certain that the unit is being operated properly and that the patient circuit and exhalation valve body / diaphragm are properly assembled and not damaged.

Symptom	Suggestions
Oxygen concentrations are high. (VSO ₂ /AVS only)	<ol style="list-style-type: none"> 1. Perform the blender transducer calibration as described in Chapter 3 of this manual, Service Verification Tests. 2. A solenoid on the blender may be leaking or stuck open. Remove blender from ventilator and apply 40-60 psi O₂. Check for flow coming out of the blender outlet. 3. Check the output flow of the turbine as described in Chapter 3 of this manual, Service Verification Tests, using the manual controls of the turbine. Low flow would indicate a need for turbine replacement. 4. Replace blender.
Oxygen concentrations are low. (VSO ₂ /AVS only)	<ol style="list-style-type: none"> 1. Perform blender transducer calibration as described in Chapter 3 of this manual. 2. A solenoid on the blender may not be opening or the drive circuitry may be malfunctioning. Check individual solenoid by manually opening each solenoid as described in Chapter 3 of this manual, Service Verification Tests. 3. Check the output flow of the turbine as described in Chapter 3 of this manual using the manual controls of the turbine. High flow would indicate a need for turbine replacement. 4. Replace blender.
Blender does not operate. (VSO ₂ /AVS only)	<ol style="list-style-type: none"> 1. Check cable from main PCBA to blender for proper connection and integrity. 2. Replace blender.
Monitored exhaled volumes are low	<ol style="list-style-type: none"> 1. Check for patient circuit leaks. 2. Check the setting of the over pressure relief valve. 3. Check passages in exhalation valve body for occlusion. 4. Ensure that a valid Flow Cal has been performed. 5. Replace exhalation valve body with a known functional unit. 6. Perform exhalation differential pressure transducer calibration.

Symptom	Suggestions
Monitored exhaled volumes are high	<ol style="list-style-type: none"> 1. This is normal when oxygen is introduced to the TBird VS. Evaluate Tidal Volume settings. 2. Perform Flow Cal procedure as described in the TBird Operator's Manuals. 3. Check passages in exhalation valve body for occlusion. 4. Replace exhalation valve body with a known functional unit and reevaluate Tidal Volume settings. 5. Perform transducer calibration procedures as described in Chapter 3 of this manual.
Delivered volumes are high	<ol style="list-style-type: none"> 1. This is normal when oxygen is introduced to the TBird VS. Evaluate Tidal Volume settings. 2. Perform transducer calibration procedures as described in Chapter 3 of this manual. 3. Replace turbine assembly.
Delivered volumes are low	<ol style="list-style-type: none"> 1. Check for leaks in the patient circuit, humidifier, or water traps. 2. Check the setting of the Over Pressure Relief Valve. 3. Check the exhalation valve body and diaphragm for mechanical integrity and proper installation. 4. Perform transducer calibration procedures as described in Chapter 3 of this manual. 5. Replace turbine assembly.
Sensitivity appears to be inaccurate or erratic	<ol style="list-style-type: none"> 1. Perform Flow Cal procedure as described in the TBird Operator's Manuals. 2. Check for leaks in the patient circuit. 3. Replace exhalation valve body and diaphragm. 4. Perform transducer calibration procedures as described in Chapter 3 of this manual.

Symptom	Suggestions
Unit is auto-triggering	<ol style="list-style-type: none"> 1. Perform Flow Cal procedure as described in the TBird Operator's Manuals. 2. Check patient circuit for leaks. 3. Check the setting of the over pressure relief valve. 4. If a test lung is being used, ensure that there is at least 5 cmH₂O/L/Sec resistance. 5. Check the exhalation valve body and diaphragm for proper installation and condition. 6. Perform transducer calibration procedures as described in Chapter 3 of this manual.
High and low pressure alarms do not seem to be accurate.	<ol style="list-style-type: none"> 1. Perform transducer calibration procedures as described in Chapter 3 of this manual. 2. Replace the Main PCB.
Peak flow does not seem to be accurate.	<ol style="list-style-type: none"> 1. Perform transducer calibration procedures as described in Chapter 3 of this manual. 2. Replace the turbine assembly.
A key or keys on the control panel do not appear to be functional.	<ol style="list-style-type: none"> 1. Check the keypad functions using the UVT procedure in the TBird Operator's Manuals. 2. Check the ribbon cables from the control panel to the Main PCB for secure connections. 3. Replace the control panel.
The ON indicator on the front panel illuminates red when the Power Switch is turned on. Ventilator is inoperative.	<ol style="list-style-type: none"> 1. This indicates a loss of some power supply voltage. 2. Check all of the connectors to the power supply for secure connections. 3. Check the fuses on the power supply PCB 4. Check the power supply voltages per the diagram in the back of this section. 5. Replace the power supply. 6. Replace the main PCB.

TECHNICAL TROUBLESHOOTING
GENERAL MALFUNCTIONS

Symptom	Suggestions
The ON indicator on the front panel illuminates amber (yellow) when the Power Switch is turned on. Ventilator is inoperative.	<ol style="list-style-type: none"><li data-bbox="519 399 1443 472">1. This indicates that the ventilator is not detecting a Program Memory card installed.<li data-bbox="519 472 1443 514">2. Install a known functional Program Memory Card.<li data-bbox="519 514 1443 588">3. Insure that the Program Memory Card is plugged into the rear slot and is securely seated in the receptacle.<li data-bbox="519 588 1443 630">4. Check for damage to the pins in the card receptacle.
Either the Internal or External Battery Charge Indicator is illuminated red and remains red for > 24 hours.	<ol style="list-style-type: none"><li data-bbox="519 661 1443 735">1. This indicates that one or both battery sets is not able to accept a charge and will not power the ventilator.<li data-bbox="519 735 1443 777">2. Check the fuse on the power supply. If it is open this may occur.<li data-bbox="519 777 1443 850">3. Replace the malfunctioning battery set with one that is known to function.

Power Supply Voltage Check

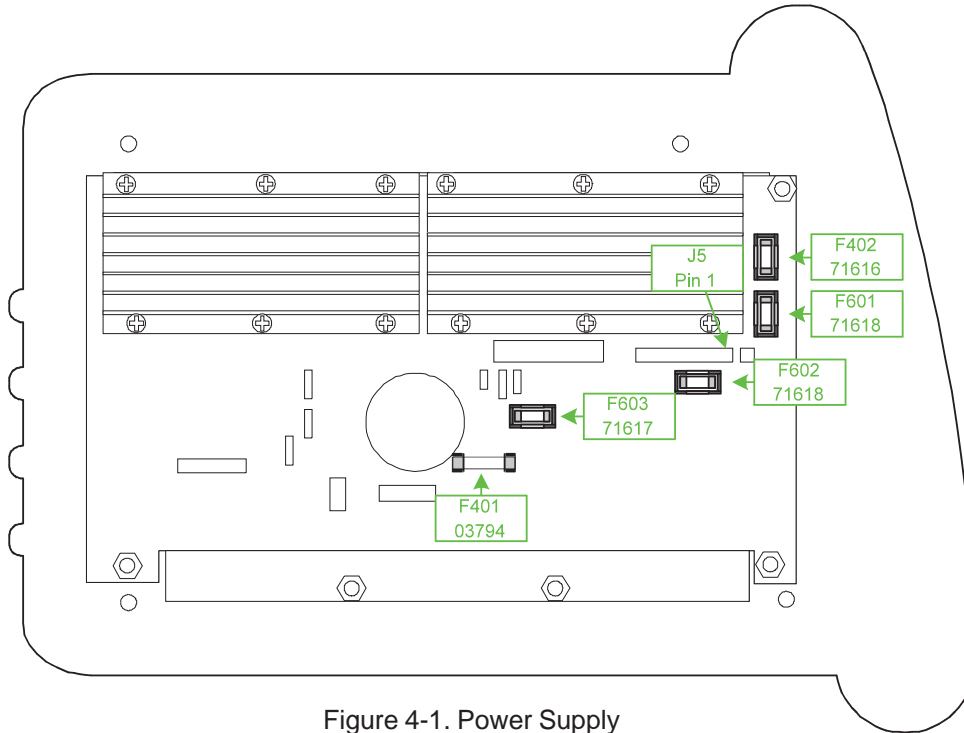

Figure 4-1. Power Supply

1. Locate connector J5.
2. Remove the white strain relief cap from the connector.
3. Connect the DVM ground to the ground stud on the rear panel of the ventilator.
4. Verify the voltages in accordance with the following table:

J5 Voltage

Pin 1	+5 Vdc \pm 6% (4.7 - 5.3 Vdc)	Pin 10	+48 Vdc \pm 6% (49.12 - 50.88)
Pin 2	+5 Vdc \pm 6% (4.7 - 5.3 Vdc)	Pin 11	Ground
Pin 3	Ground	Pin 12	+48 Vdc \pm 6% (49.12 - 50.88)
Pin 4	+8 Vdc \pm 6% (7.52 - 8.48 Vdc)	Pin 13	Int S+ (N/A-Internal Battery Sense)
Pin 5	+8 Vdc \pm 6% (7.52 - 8.48 Vdc)	Pin 14	Ext S+ (N/A-External Battery Sense)
Pin 6	Ground		
Pin 7	+24 Vdc \pm 6% (24.56 - 25.44 Vdc)		

J5 Voltage

Pin 8	+24 Vdc \pm 6% (24.56 - 25.44 Vdc)
Pin 9	Ground



This page intentionally left blank.

CHAPTER 5 – REMOVAL AND REPLACEMENT

What This Chapter Describes

This section of the TBird Ventilator Series Service Manual deals with the procedures for parts replacement within the TBird ventilator.

Tools Required:

- Common Screwdriver
- Phillips Cross-tip Screwdriver
- Common Pliers
- Needle Nose Pliers
- Anti-Static Wrist Strap
- Integrated Circuit Removal Tools
- Thin Walled 11/32" Socket or Nut Driver

In most cases, reassembly is simply a reversal of the disassembly process. If there are any special instructions they will be added at the end of the removal process.

The following **WARNINGS** and **CAUTIONS** should be read and understood before accessing the interior of the ventilator:



WARNING



Electrical shock hazards are present within the ventilator even after AC power has been removed. It is recommended that the top cover be electrically unplugged to disconnect the batteries from the ventilator.



CAUTIONS



Appropriate measures to prevent ESD damage to electronic components must be taken:

- Wear a properly grounded and tested anti-static wrist strap when handling PCB's.
- Work on an anti-static surface.
- Always use anti-static material for packaging PCB's.



Attached to the top cover of the ventilator is a large energy storage capacitor that may have some residual charge. Use extreme care not to allow any conductive material to contact the electrical connections.

Table of Contents

Part	Page
7 Segment Red Display	5-17
7 Segment Yellow Display	5-17
Alarm Loudness Potentiometer	5-24
Anti-Suffocation Valve	5-26
Base Plate O-Rings	5-26
Blender Assembly	5-21
Configuration Memory Card	5-6
Control Panel	5-15
Display PCBA	5-15
Dot Matrix Displays	5-17
EMI/RFI Filter	5-24
Energy Storage Capacitor	5-10
Exhalation Differential Pressure Transducer	5-25
Exhalation Valve	5-19
External Docking Bay	5-28
Fan Assembly	5-22
Fan EMI Filter	5-22
Fan Inlet Filter	5-22
Front Panel	5-14
Fuse Holder	5-24
Internal Batteries	5-10
Main PCBA	5-15
Motor Controller PCBA	5-12
Muffler/Filter Core Assembly	5-18
Outlet Check Valve Assembly	5-27
Overlay	5-15
Panel Encoder Assembly	5-15
Patient Assist Call	5-23
Power Supply Removal	5-9
Program Memory Card and Configuration Memory Card	5-6
Protective Cover Removal	5-8
Relief Valve Assembly	5-27
Socketed LED	5-17
Standby/On Switch	5-24
Top Cover	5-5
Turbine Assembly	5-20
Turbine Differential Pressure Transducer	5-25
Ventilator Left and Right Side Cover Removal	5-3
Watch Dog PAL	5-13
Wire Harness and Cable Assemblies	5-34

Ventilator Left and Right Side Cover Removal

For most removal and replacement operations, the covers must be removed from the ventilator. Note that it is necessary to remove the left and right side covers before the removal of the top cover can be accomplished.

 **CAUTION** 

Prior to cover removal, disconnect AC power from the wall source and ensure that the Standby/On Switch is in the Standby Position.

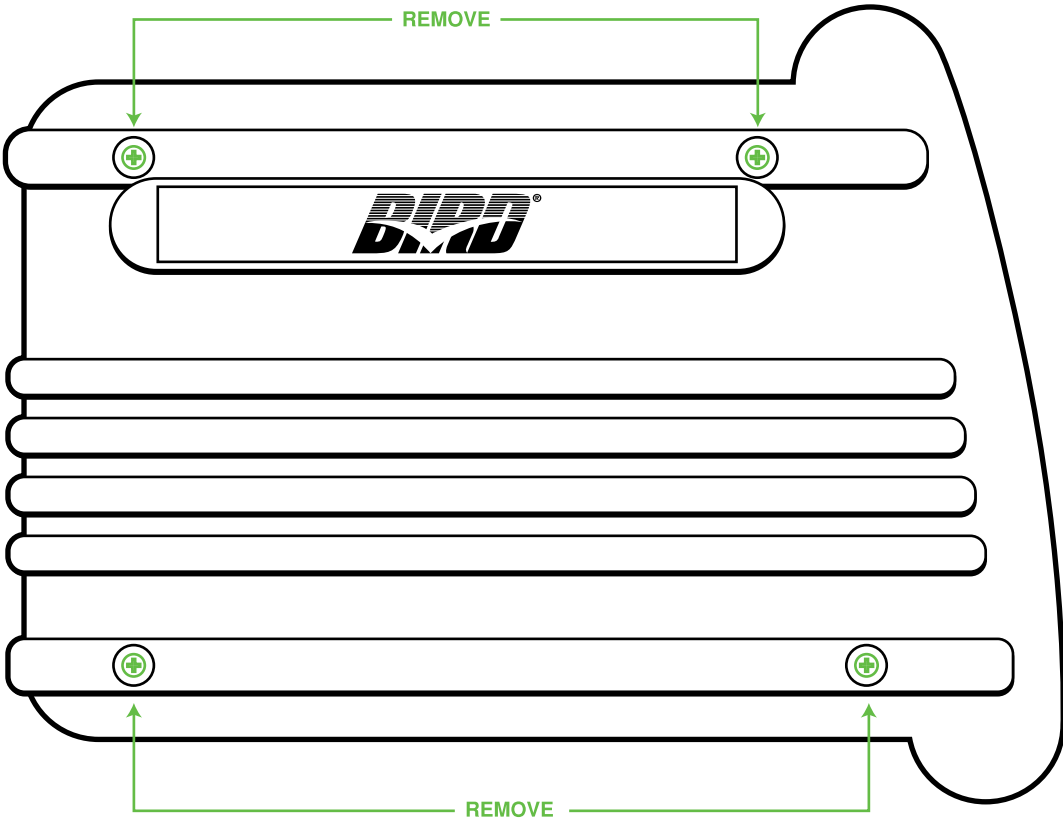

Figure 5-1. Ventilator Left and Right Side Cover Removal

Left Side Cover

1. Referring to Figure 5-1, use a Phillips screwdriver and remove the four (4) screws securing the left side cover.
2. Remove the left side cover and set aside.

Ventilator Left and Right Side Cover Removal (Continued)

Right Side Cover



CAUTION



The Power Supply is mounted to the right side cover of the ventilator. Removal must be done carefully to insure that wire harnesses are not strained and that the Power Supply components are not allowed to contact electrically conductive materials of the ventilator including the shield coating on the inside of the ventilator.

1. Using Figure 5-1 as a reference, remove the (4) Phillips screws securing the right side cover to the ventilator chassis.
2. Gently pull the right side panel away from the ventilator and set it on the work surface in a vertical position, leaning against the ventilator chassis.
3. Some insulating material may be used to hold the right side panel away from the chassis of the ventilator.



WARNING



Electrical shock hazards are present within the ventilator even after AC power has been removed. Pay particular attention to the large electrolytic capacitor mounted to the Top Cover.

Top Cover

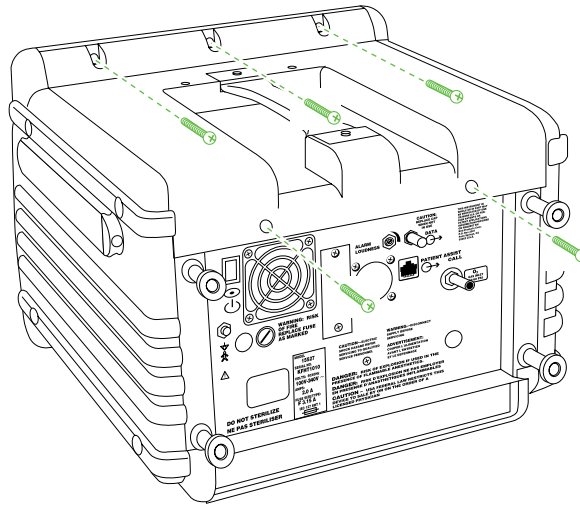

Figure 5-2. Top Cover Removal

1. Perform the procedure to remove the left and right side covers.
2. Referring to Figure 5-2, remove the three (3) screws from the top front of the ventilator.
3. Holding the top cover, remove the two (2) screws from the rear of the ventilator.
4. Lift the cover slightly in the rear and pull back and away from the ventilator.
5. Set the ventilator cover on the work surface at the rear of the ventilator.
6. Unplug the large white connector connected to the top cover, hold the locking tabs depressed and pull the opposite side of the connector. Set the top cover aside.

Program Memory Card and Configuration Memory Card



CAUTION



When handling the Program Memory Card or the Configuration Memory Card and contacting the inside of the ventilator, precautions must be taken to avoid ESD damage. An anti-static wrist strap should be worn and correctly grounded while performing this procedure. At a minimum, always touch the copper colored coating inside of the chassis to equalize potential charges prior to placing the card in the ventilator.

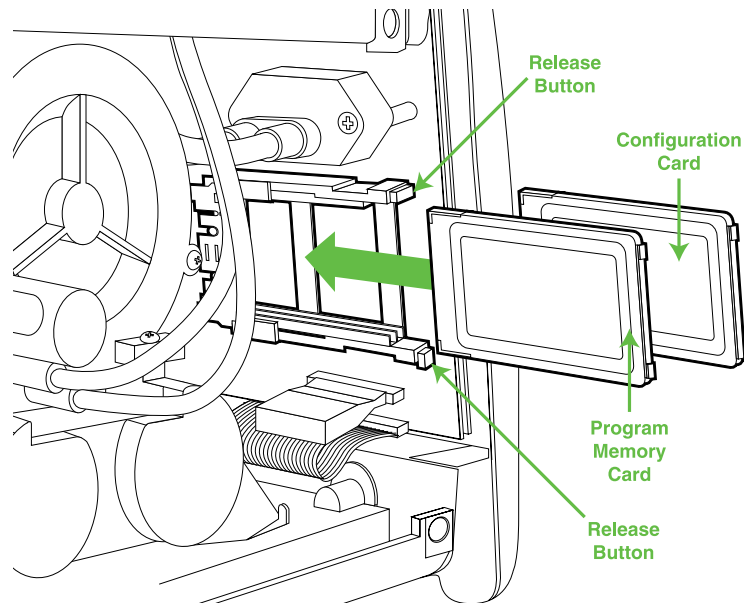

Figure 5-3. Program Memory Card and Configuration Memory Card

1. Remove AC Power from the ventilator wall source.
2. Verify that the **ON/STANDBY** switch in the rear of the ventilator is in the **STANDBY** position.
3. Refer to the procedure for the removal of the left side cover of the ventilator.
4. Referring to Figure 5-3, press the release button on the lower edge of the card receptacle to eject the Program Memory Card. Note the orientation of the Program Memory Card as it is removed from the ventilator.

Program Memory Card and Configuration Memory Card (Continued)

5. Referring to Figure 5-3, press the release button on the upper edge of the card receptacle to eject the Configuration Memory Card. Note the orientation of the Configuration Memory Card as it is removed from the ventilator.

Note

The Program Memory Card is installed in the rear card holder rails as viewed from the front of the ventilator. Installation in the front slot will do no damage but the ventilator will not operate and will show an amber/yellow illumination of the **ON** led on the front panel.

Note

The Configuration Memory Card is installed in the front card holder rails as viewed from the front of the ventilator. Installation in the rear slot will do no damage but the ventilator will not operate and will show an amber/yellow illumination of the **ON** led on the front panel.

1. Insert the replacement Program Memory Card in the rear slot with the label facing to the front of the ventilator and the arrow pointing up as shown on the label viewed from the front of the ventilator.
2. Insert the Configuration Memory Card in the front slot with the label facing to the front of the ventilator and the arrow pointing up as shown on the label viewed from the front of the ventilator.
3. Replace the left cover of the ventilator and perform the operational check as described in the TBird Operator's Manual.

Note

When the Program Memory Card contains a different version of software than was previously installed, the message **FLASH UPDATE** will be displayed in the monitor window as the parameters are read into the ventilators memory. Following this the ventilator will operate at default settings until new parameters are entered.

Protective Cover Removal

 **Note**

If a left or right protective cover is being replaced, be aware that it is composed of two sections; the pliable outer portion and the inner reinforcing plate. The side rail assemblies are NOT included. These items have individual part numbers. See Chapter 7, Parts List, of this manual for details.

1. Remove the selected cover completely from the ventilator.
2. If the right protective cover is being replaced, follow the procedure for removal of the power supply.
3. Remove the side rail assembly.

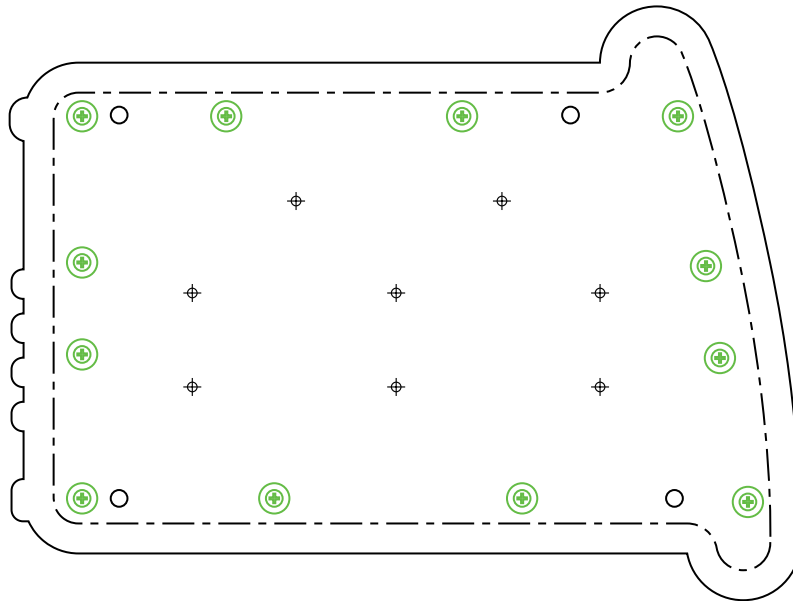

Figure 5-4. Protective Side Covers

4. Referring to Figure 5-4, remove the twelve (12) flat head screws from the reinforcing plate.
5. To separate the two portions, peel the pliable cover away from the reinforcing plate.
6. To re-assemble, align the plate with the protrusions and pull them through using pliers and reverse the disassembly process.

Power Supply Removal (P/N 50590)

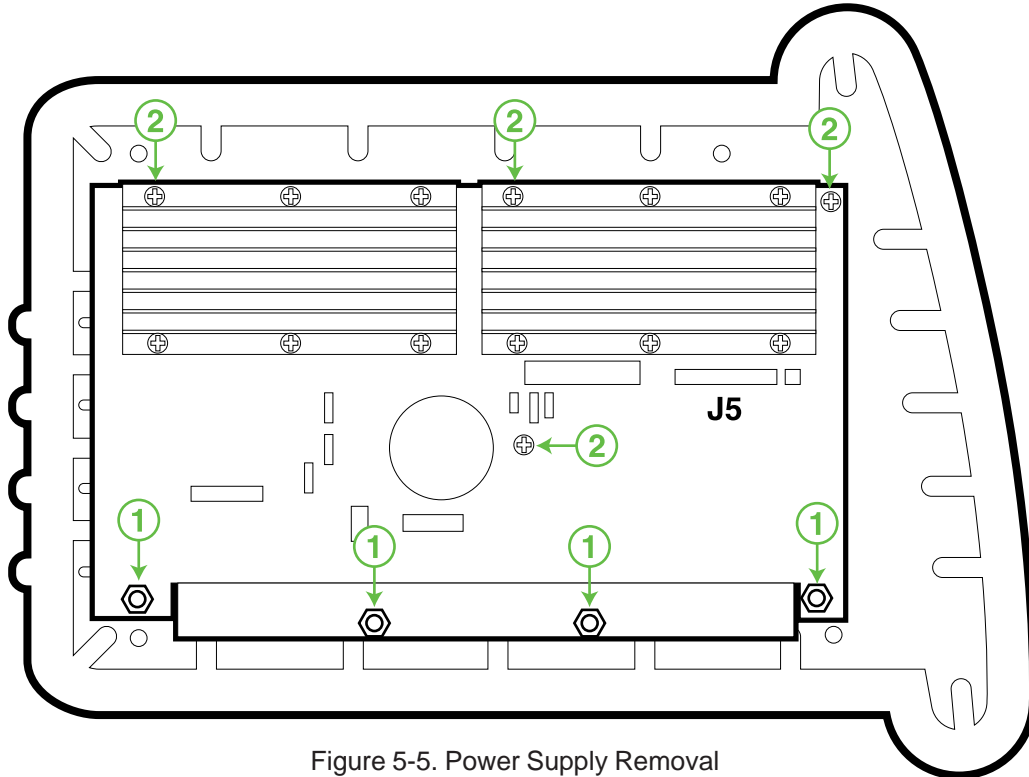

Figure 5-5. Power Supply Removal

1. Perform the procedure for removing right cover from the ventilator.
2. Remove the electrical connections to the Power Supply noting position and orientation.
3. Referring to Figure 5-5, remove the four (4) nuts (Figure 5-5, ref. 1) and four (4) screws (Figure 5-5, ref. 2) securing the Power Supply to the to the right side cover.
4. Place the Power Supply in anti-static packaging for shipment.



CAUTION



Before assembling the ventilator, be sure to double check the alignment of connector J5. Misalignment of this connector can cause catastrophic damage to the Power Supply and/or the Main PCB.

5. To install the replacement Power Supply, refer to Table 5-1, at the end of this section, for electrical connections and reverse the removal process.

Internal Batteries (P/N 68093)

Energy Storage Capacitor (P/N 64084)

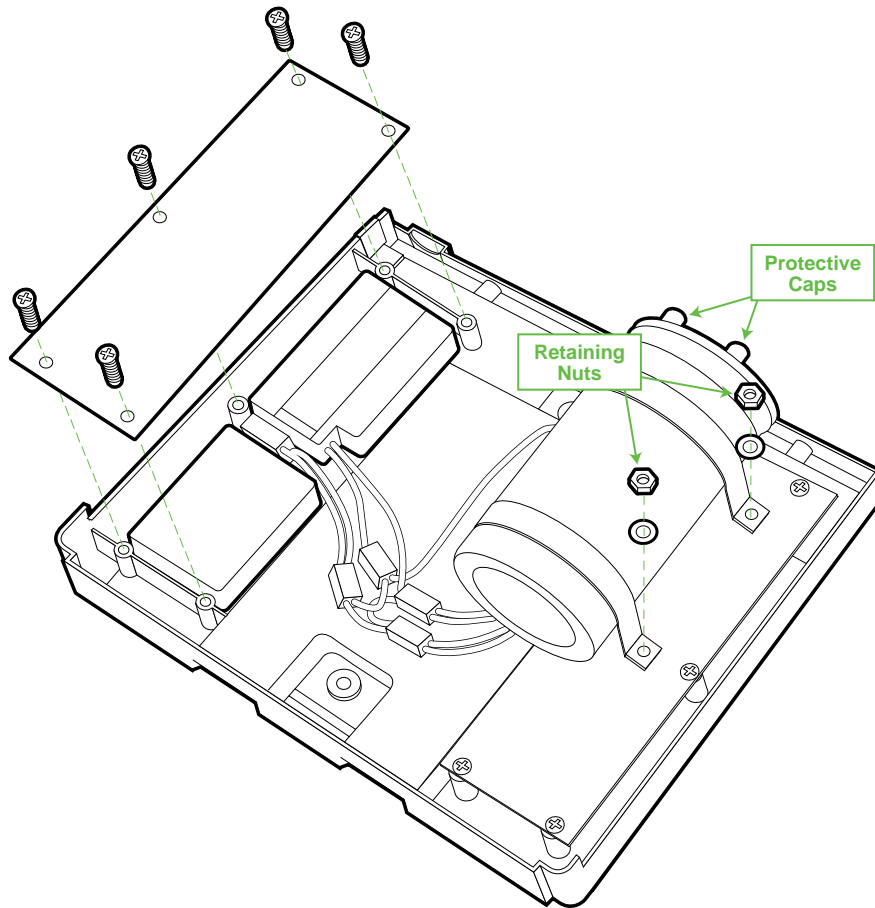

Figure 5-6. Internal Batteries / Energy Storage Capacitor

 **Note**

If it has been determined that one or more of the Internal Batteries are defective, it is recommended that all four (4) be replaced as a set. A defective battery may effect the life or performance of the remaining batteries.

1. Perform the procedure for the removal of the ventilator top and side covers.
2. To remove the batteries, refer to Figure 5-6 to remove the five (5) screws from the battery retaining plate.

Internal Batteries (P/N 68093) (Continued)

Energy Storage Capacitor (P/N 64084) (Continued)

 **Note**

To remove the batteries from the left side of the top cover, the large capacitor must be removed first.

3. To remove the Energy Storage Capacitor, remove two (2) of the nuts from the restraining straps, remove the electrical connections, and slide the capacitor from the straps.

 **Note**

When installing the capacitor, ensure that the white wires are connected to the positive (+) terminal and the black wires are connected to the negative terminal. Also note that the vent plug on the capacitor must be orientatied towards the top of the ventilator. Ensure protective caps are reinstalled on the capacitor terminals.

Motor Controller PCBA (P/N 71597)

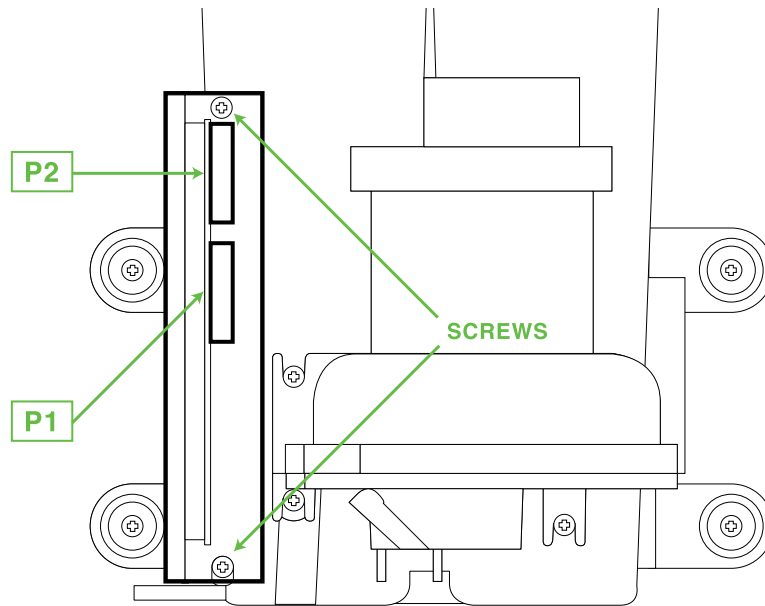

Figure 5-7. Motor Controller

1. Perform the procedures to remove the top and side covers from the ventilator.
2. Referring to Figure 5-7, remove connector P1 (coming from the Turbine) and P2 (coming from the Power Supply) from the Motor Controller noting the edges that engage the locking tabs.
3. Remove the two (2) screws securing the Motor Controller bracket to the muffler assembly.
4. Place the PCB in appropriate anti-static packaging for shipment.

 **Note**

When connector P2 is installed, a small electrical spark may be noticed. This is normal due to a residual charge remaining on system capacitors.

Watch Dog PAL (15532)

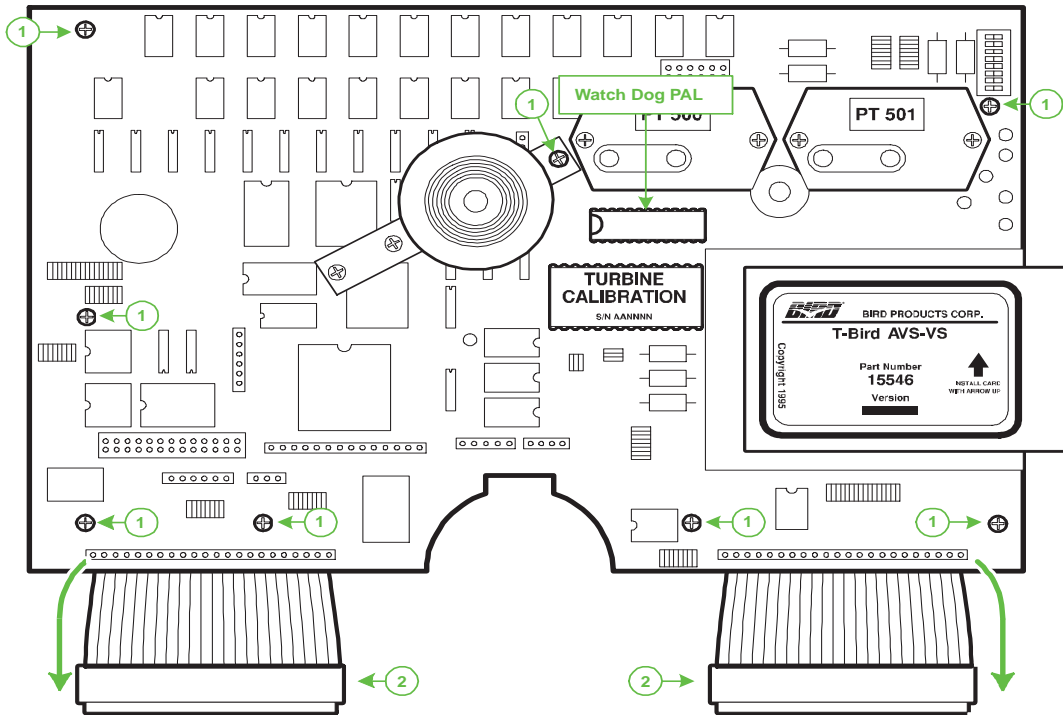

Figure 5-8. Main PCB, Watch Dog PAL

1. Perform the procedure to remove the top and side covers from the ventilator.
2. Referring to Figure 5-10 Ref. 1, remove the two (2) screws that secure the front panel assembly to the ventilator base and rock the front panel forward.
3. Referring to Figure 5-8, locate the Watch Dog PAL on the Main PCB.
4. Using an IC extraction tool, remove the PAL and place the chip in appropriate anti-static material.
5. Install the new PAL using caution as to proper pin alignment and position of pin 1 indicated by the notch in the PAL IC. Do Not rely on the orientation of the label for IC installation.

REMOVAL AND REPLACEMENT

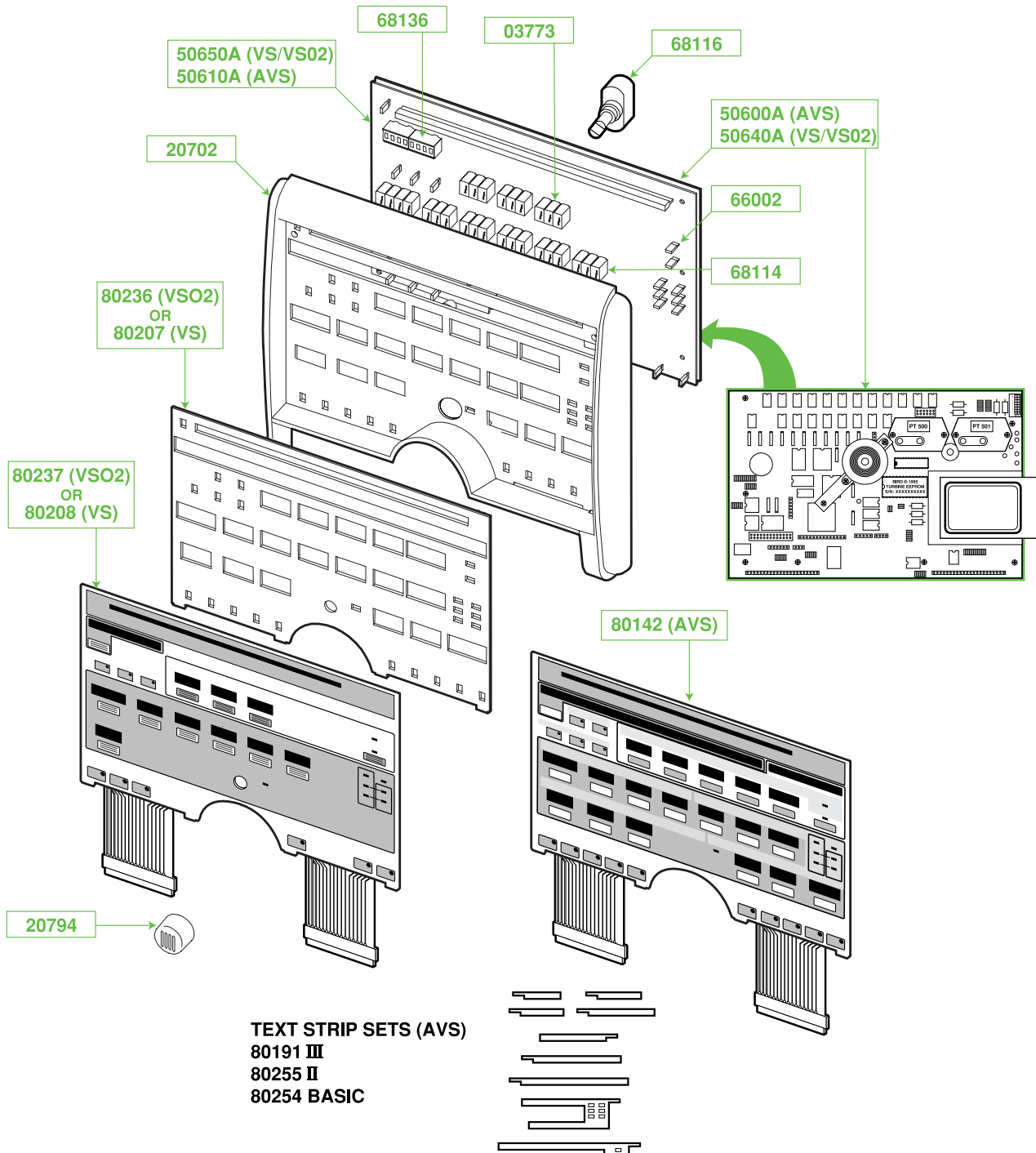

Figure 5-9. Front Panel Disassembly

Panel Encoder Assembly - P/N 68116
Main PCBA - P/N 50640A (VS/VS02) or P/N 50600A (AVS)
Display PCBA - P/N 50650A (VS/VS02) or P/N 50610A (AVS)
Front Panel - P/N 20702
Control Panel - P/N 80207 (VS) or P/N 80236 (VS₂)
Overlay - P/N 80208 (VS) or P/N 80237(VS₂)
Control Panel/Overlay - P/N 80142 (AVS)

1. Perform the procedure to remove the top and side covers from the ventilator.
2. To remove the Front Panel Encoder: Refer to Figure 5-9.
 - a) Remove the electrical connector from the rear of the panel encoder noting orientation.
 - b) Pull on the knob P/N 20794 to remove it from the encoder shaft.
 - c) Perform the procedure to remove the front panel and overlay from the ventilator without unplugging the cables to the Main PCB.
 - d) Using a 1/2" nut driver or socket, remove the mounting nut from the encoder P/N 68116 and remove the panel encoder through the inside of the ventilator.

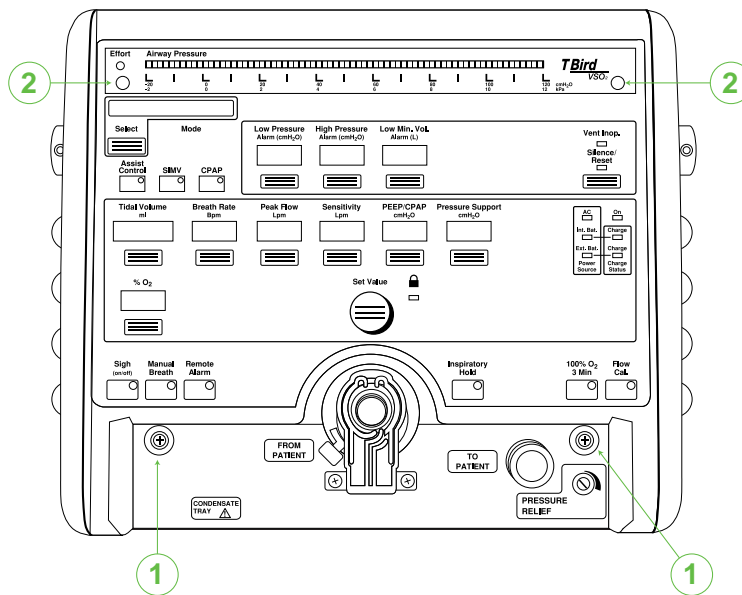

Figure 5-10. Front Panel Encoder Removal

3. To remove the control panel and overlay:
 - a) Disconnect the two (2) ribbon cables in the lower corners of the Main PCBA. (Refer to Figure 5-9.)

REMOVAL AND REPLACEMENT

- b) Remove the two (2) screws from the upper corners of the control panel (Refer to Figure 5-10 Ref. 2).
 - c) Using a small screwdriver in the screw holes, pull the upper edge of the control panel forward and up to disengage the retaining tabs at the bottom of the panel.
 - d) Gently remove the control panel with particular attention to the ribbon cables as they clear the slots in the front panel.
4. To remove the Main PCBA or Display PCBA:
- a) Disconnect the pneumatic and electrical connections from the Main PCBA.
 - b) Remove the two (2) screws from the lower part of the front panel (Refer to Figure 5-10 Ref. 1) and remove the front panel from the ventilator.
 - c) Remove the eight (8) screws securing the Main and Display PCBs to the front panel. Note that one (1) mounting screw is on the alarm. (Refer to Figure 5-8, Ref 1.)
 - d) Disconnect the two (2) ribbon cables attached to the lower corners of the Main PCBA. (Refer to Figure 5-8, Ref 2.)
 - e) Remove the Main and Display PCBs from the front panel.
 - f) Gently disengage the connector in the lower left corner of the of the two (2) PCBs.

Note

If returning the Main PCBA, do not return the Memory Cards or the Turbine Calibration EEPROM unless instructed to do so.

- g) Place the PCB in appropriate anti-static packaging for shipment.
5. To remove the front panel:
- a) Complete the 3 procedures at the beginning of this section.

7 Segment Red Display (P/N 03773)
Dot Matrix Displays (P/N 68136)
Socketed LED (P/N 66002)
7 Segment Yellow Display (P/N 68114)

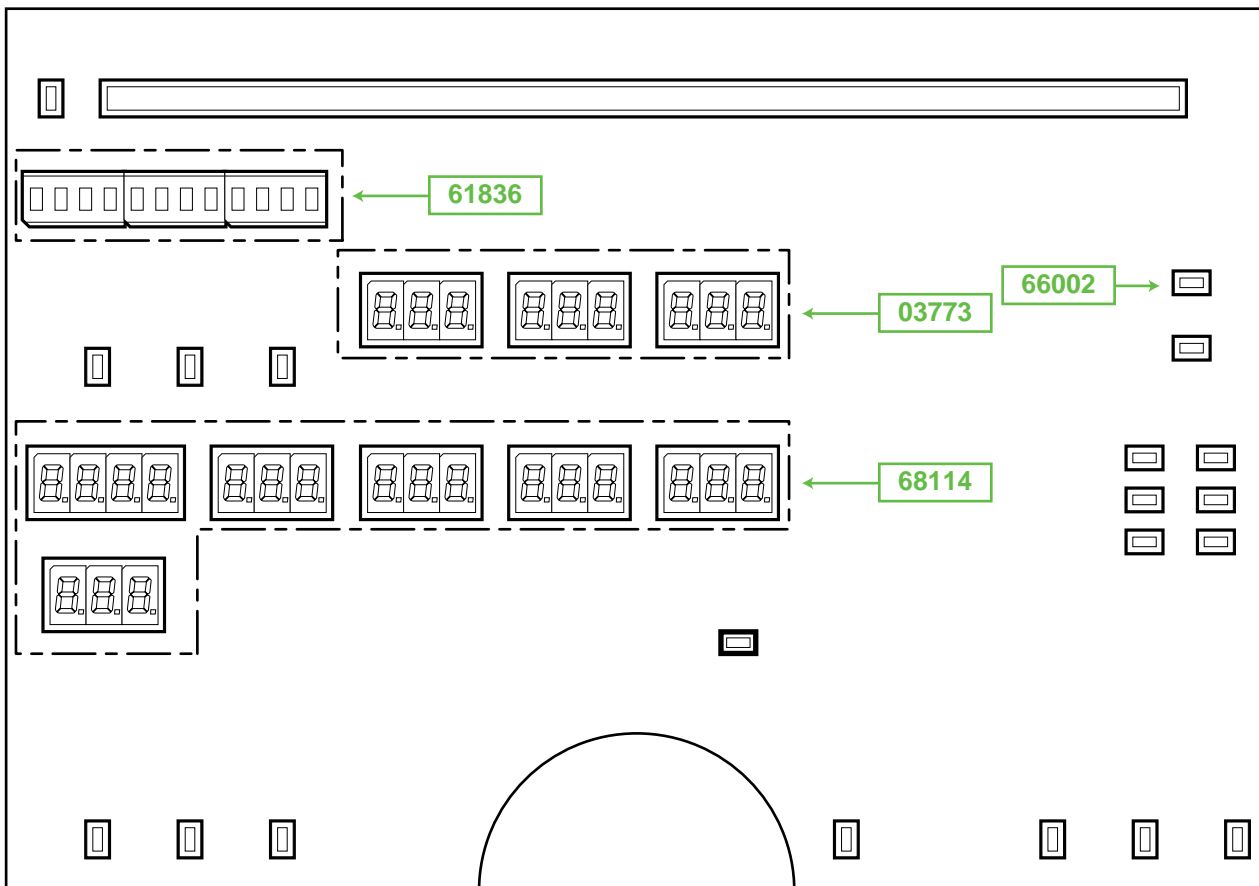

Figure 5-11. Displays

1. Perform the procedure to remove the covers from the ventilator.
2. After labeling or noting positions, remove the cables and pneumatic connections from the Main PCBA.
3. Perform the procedure for the removal of the Display PCBA.
4. Remove and replace the malfunctioning display element observing polarity and proper engaging of pins.

Muffler/Filter Core Assembly (P/N 10365)

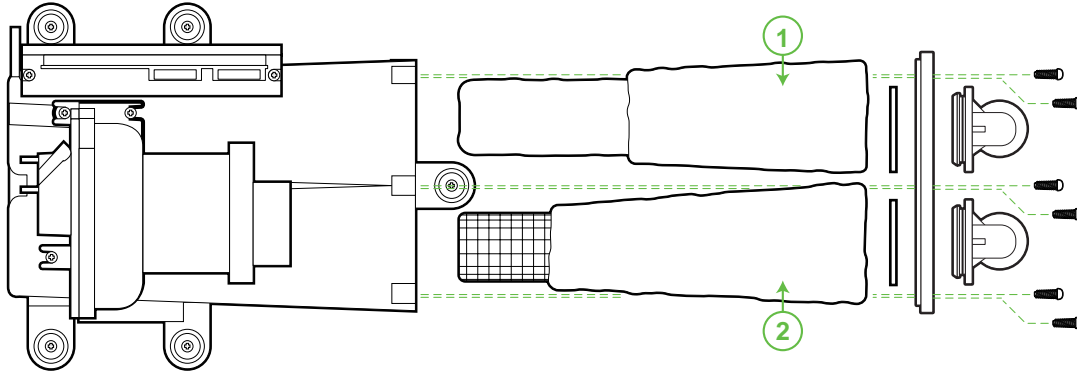

Figure 5-12. Muffler/Filter Core Assembly

1. Perform the procedure to remove the right side cover from the ventilator.
2. Remove connectors J1 and J5 (refer to Chapter 6, Schematics) from the Power Supply PCBA.
3. Swing the right side cover away from the unit.
4. Referring to Figure 5-12, remove the six (6) screws holding the end caps on the muffler tube and remove the caps and elbows as an assembly.
5. Using a pair of pliers, grasp the inner screen of the rear filter (Ref. 1) and using a clockwise pulling motion, remove the element from the tube.
6. Referring to Figure 5-12, insert the element with the filter into the tube using a clockwise insertion motion.
7. Remove and replace the remaining element (Ref. 2) as described above.



CAUTION



Before assembling the ventilator, be sure to double check the alignment of connector J5. Misalignment of this connector can cause catastrophic damage to the Power Supply and/or the Main PCB.

Exhalation Valve - (P/N 15429)

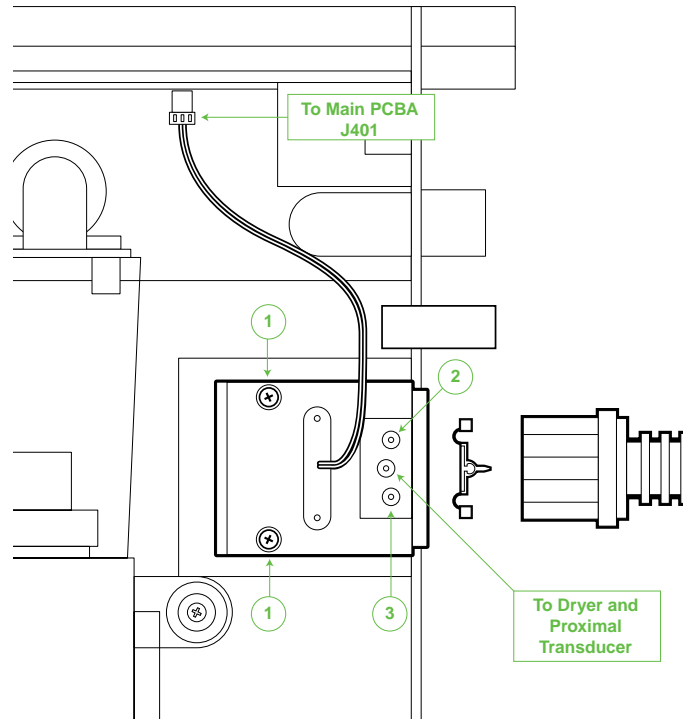

Figure 5-13. Exhalation Valve

1. Perform the procedure to remove the top and side covers from the ventilator.
2. Remove the Exhalation Body and Exhalation Diaphragm from the ventilator.

 **Note**

Referring to Figure 5-13, the two outside tubes should be labeled as 2 and 3 with plastic bands. If they are not, label these tubes with masking tape or make a drawing for correct assembly.

3. Remove the three (3) pneumatic tubes to the Exhalation Valve, labeling or noting their position for proper assembly.
4. Unplug the cable going to the Main PCBA, (refer to Chapter 6, Schematics, pg. 6-1) noting the orientation of the connector.
5. Remove the two (2) Phillips screws (Figure 5-13, ref. 1) from the top of the Exhalation Valve.
6. Lift the Exhalation Valve back and up to remove it from the ventilator.

Turbine Assembly - (P/N 15430A) (Includes Turbine EEPROM and Cable)

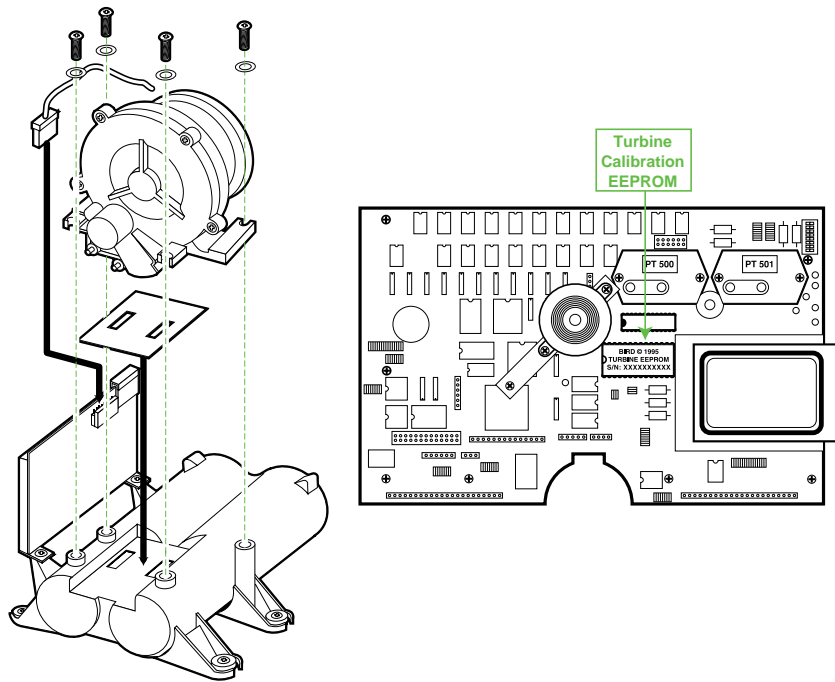

Figure 5-14. Turbine Assembly

1. Perform the procedure to remove the top and side covers from the ventilator.
2. Unplug the connector J701 (refer to Chapter 6, Schematics, page 6-1) from the Main PCBA.
3. Unplug connector P1 (refer to Chapter 6, Schematics, page 6-1) from the motor controller noting orientation.
4. Label and remove the two (2) pneumatic connections from the turbine.
5. Referring to Figure 5-14, remove the four (4) screws from the base of the turbine.
6. Lift the turbine assembly from the muffler tube, retaining the silicone gasket under the turbine for re-use.
7. Using masking tape, cover the inlet and outlet openings of the turbine and the muffler tube to prevent the entry of foreign material into the assemblies.
8. Using the EEPROM removal tool, remove the EEPROM from the Main PCBA and place into appropriate anti-static material.
9. Referring to Figure 5-14, install the new turbine EEPROM making sure that the notch is facing to the left and that pins are properly aligned and engaged. Do not rely on the position of the label for installation.
10. After installing the new turbine it will be necessary to enter the turbine serial number into the ventilators memory. Refer to Chapter 3, SVT, of this manual for instructions.

Blender Assembly - (P/N 15581) (TBird™ VSO₂ and AVS)

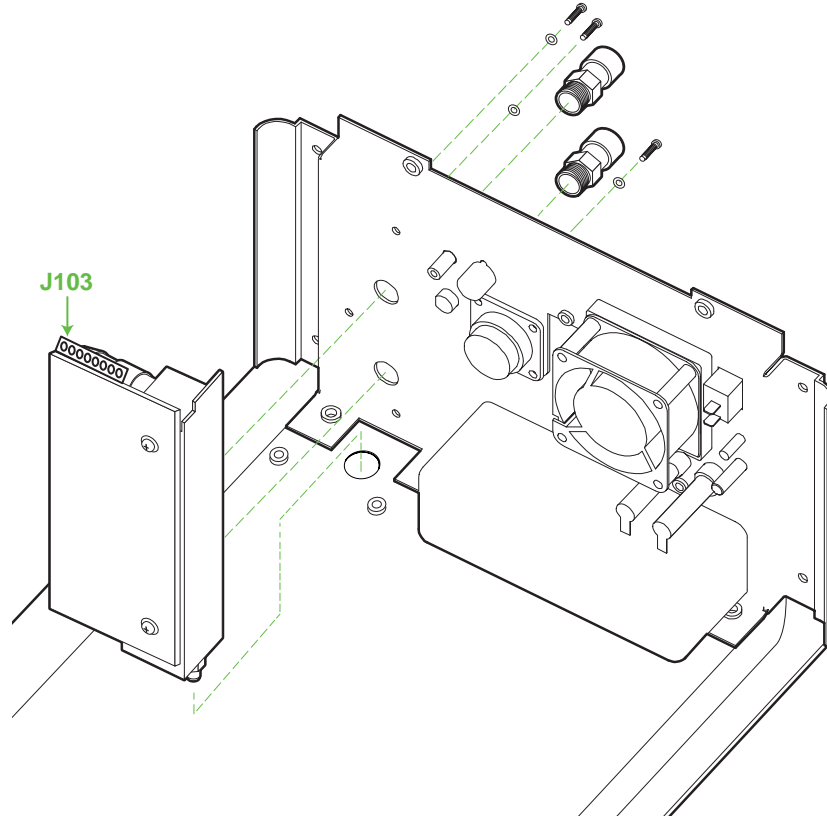

Figure 5-15. Blender Assembly

1. Perform the procedure to remove the top and side covers from the ventilator.
2. Remove the Rear Inlet Filter.
3. Reaching in through the filter cavity with needle nose pliers, disconnect the hose coming from the base of the blender.
4. Remove the electrical connector J103 from the blender noting orientation.
5. Referring to Figure 5-15, remove the pair of O₂ DISS fittings from the rear of the ventilator. Take precaution not to lose springs within the fittings.
6. Remove the two (2) screws from the rear of the ventilator that secure the blender to the chassis.
7. Lift the blender from the ventilator.
8. After installation of the replacement blender, perform the Oxygen Pressure Transducer calibration as described in Chapter 3, SVT, of this manual.

Patient Assist Call - (P/N 50570)

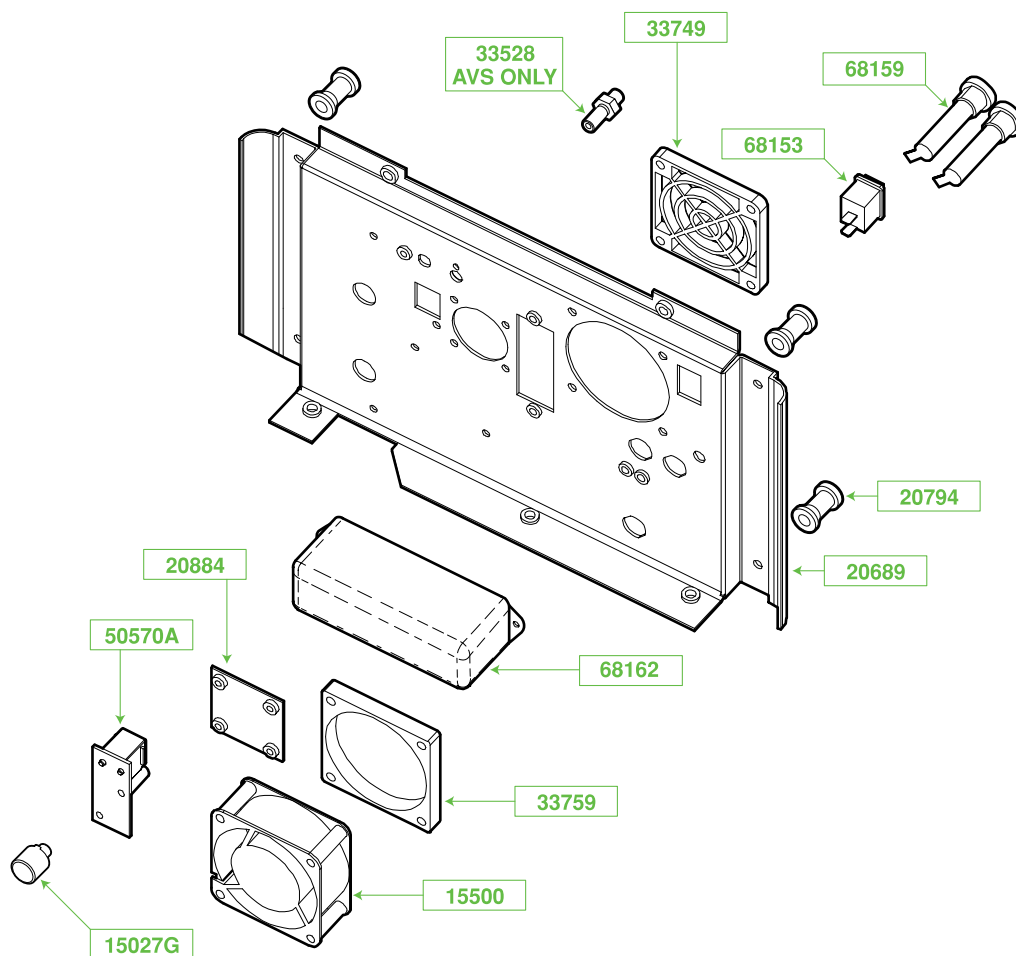

Figure 5-17. Patient Assist Call

Refer to Figure 5-17.

1. Perform the procedure to remove the covers from the ventilator.
2. Locate and remove the electrical connector from the Patient Assist Call PCBA, P/N 50570A noting its orientation.
3. Remove the two (2) screws securing the Patient Assist Call PCBA, P/N 50570A to the standoffs on the rear panel.
4. Remove the Patient Assist Call PCBA from the ventilator.

Standby/On Switch - (P/N 68153)

Refer to Figure 5-17.

1. Perform the procedure to remove the top and side covers from the ventilator.
2. Disconnect the brown and black wires from the switch.
3. Compress the retaining tabs on the top and bottom of the switch and slide it out of the rear of the ventilator.
4. Noting correct orientation, insert the new switch into the ventilator with the electrical connections towards the bottom of the unit.
5. Attach the brown and black wires to the switch and test for proper operation.

Fuse Holder - (P/N 68159)

Refer to Figure 5-17.

1. Perform the procedure to remove the top and side covers from the ventilator.
2. Noting their location, remove the two (2) wires from the fuse holder.
3. Loosen and remove the large nut on the inside of the back panel that secures the fuse holder to the panel.
4. Remove the fuse holder from the unit.

Alarm Loudness Potentiometer - (P/N 15027G)

Refer to Figure 5-17.

1. Perform the procedure to remove the top and side covers from the ventilator.
2. Unplug the alarm loudness cable from the Main PCB.
3. Remove the alarm loudness mounting nut from the rear of the unit and remove the control.

EMI/RFI Filter - (P/N 68162)

Refer to Figure 5-17.

1. Perform the procedure to remove the top and side covers from the ventilator.
2. Disconnect the wires from the filter and note the location.
3. Remove the two (2) nuts securing the filter to the rear of the ventilator and remove the filter from the ventilator.

**Turbine Differential Pressure Transducer - (P/N 68125)
Exhalation Differential Pressure Transducer - (P/N 68126)**

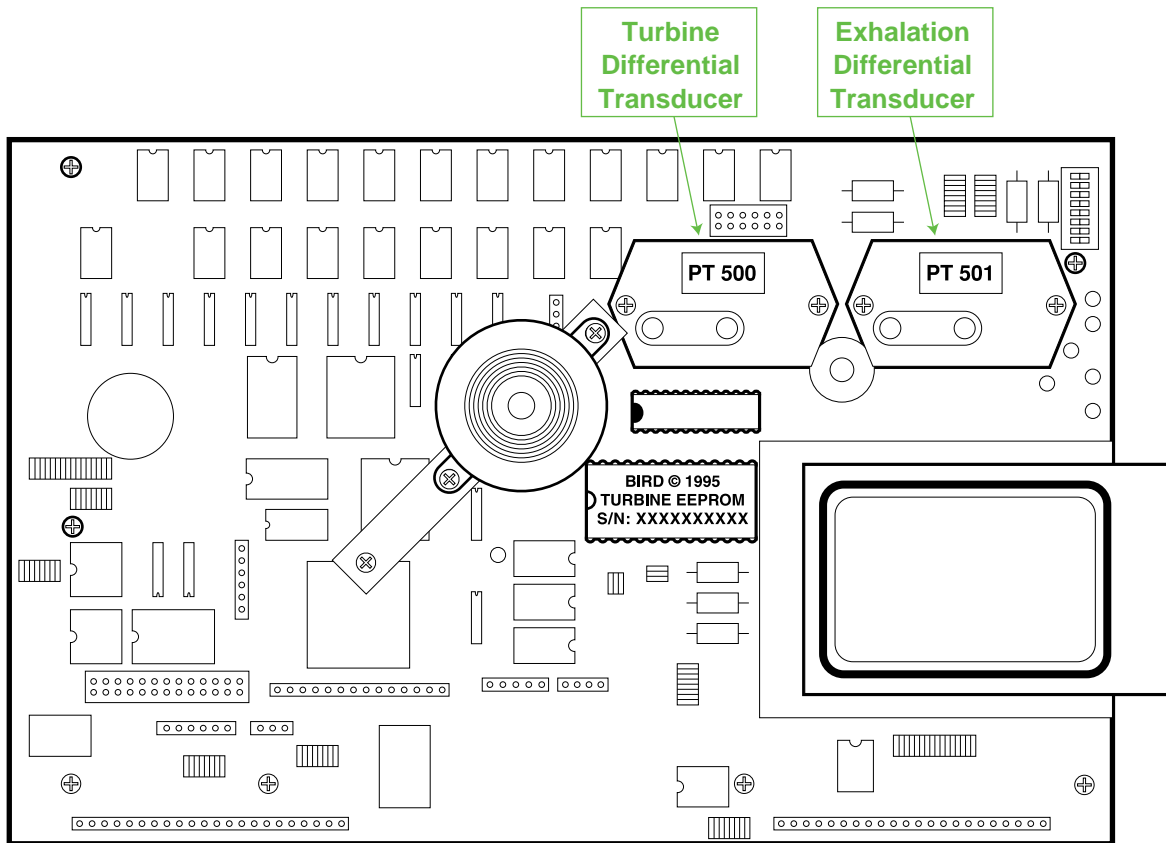

Figure 5-18. Turbine Differential Pressure Transducer and Exhalation Pressure Differential Transducer

1. Perform the procedure to remove the top and side covers from the ventilator.
2. Referring to Figure 5-18, label or note the position of the pneumatic connections to the pressure transducer and remove them.
3. Remove the two (2) screws retaining the pressure transducer to the Main PCBA.
4. Unplug the pressure transducer from the Main PCBA.
5. After installing the new transducer perform the transducer calibration procedure as described in Chapter 3, SVT, of this manual.

Base Plate O-Rings Anti-Suffocation Valve

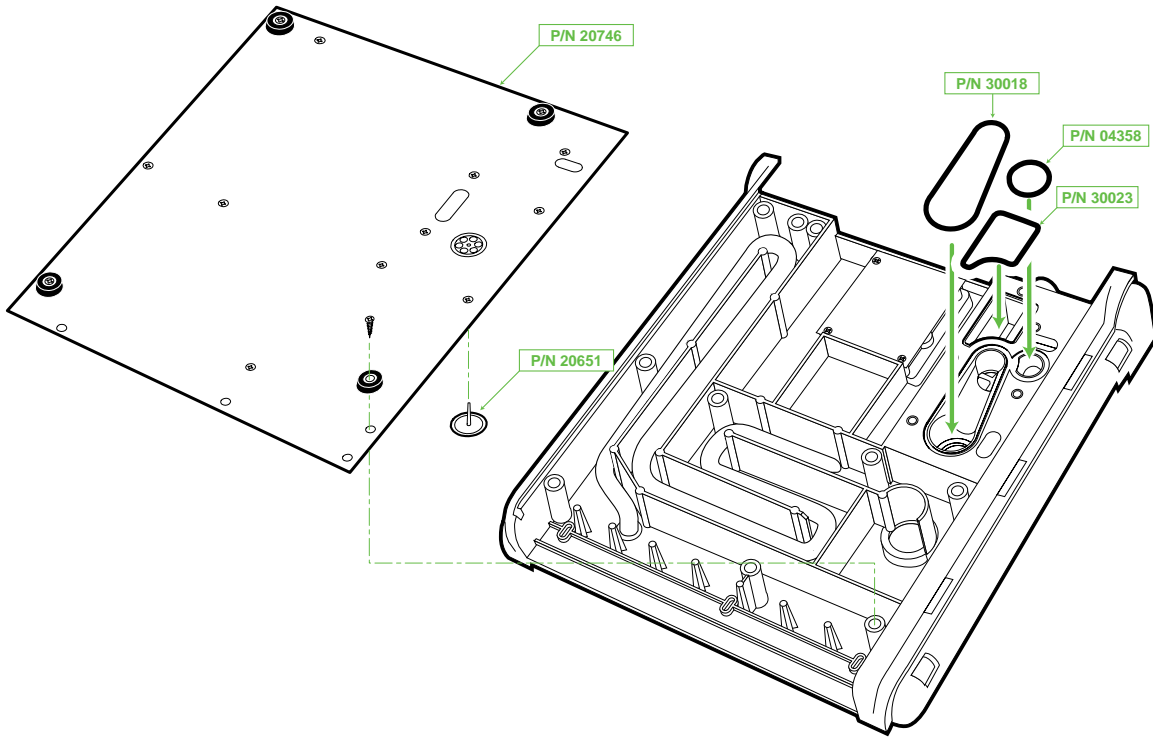

Figure 5-19. Base Plate O-Rings and Anti-Suffocation Valve

1. Place the ventilator upside down on the work surface.
2. Referring to Figure 5-19, remove the four (4) rubber bumpers from the base plate.
3. Remove the ten (10) screws securing the base plate to the ventilator chassis and remove the base plate.
4. If replacing the base plate o-rings, insert them into the lands as shown.
5. If replacing the anti-suffocation valve, place the tail of the valve from the inside of the base plate and pull the tail through using caution as not to break the tail.

Outlet Check Valve Assembly Relief Valve Assembly

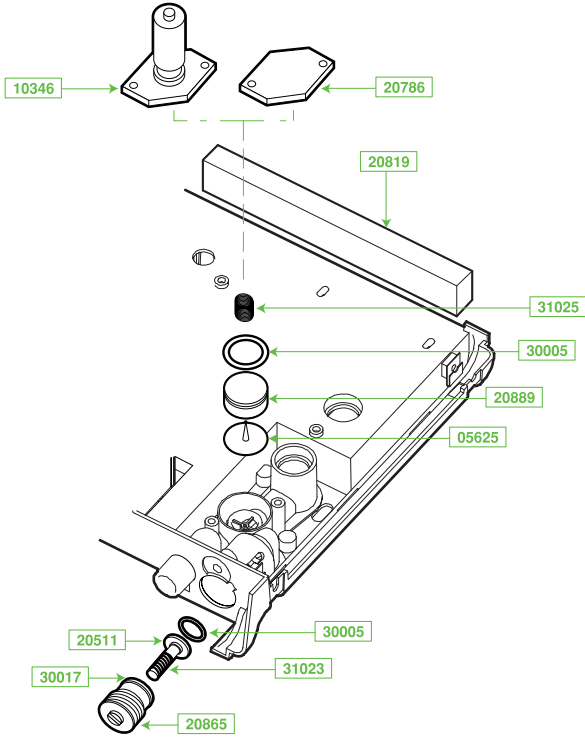

Figure 5-20. Outlet Check Valve Assembly and Relief Valve Assembly

1. To replace components of the Outlet Check Valve Assembly:
 - a) Perform the procedure to remove the right cover from the ventilator.
 - b) Referring to Figure 5-20, remove the cover plate (P/N 20786) using a short Phillips screwdriver and withdraw the components.

2. To replace components of the Relief Valve Assembly:
 - a) Perform the procedure to remove the top and side covers from the ventilator.
 - b) Perform the procedure to remove the front panel from the ventilator.
 - c) Referring to Figure 5-20, back out the Relief Valve Adjuster (P/N 20865) and remove it and its components from the ventilator.
 - d) When installing the Relief Valve, insure that the adjuster is screwed in sufficiently to avoid interference when the Front Panel is installed.

EXTERNAL DOCKING BAY



WARNING



Installation of the External Docking Bay requires access to the interior of the ventilator. It is intended to be performed by a Bird Certified Service Technician who is trained to work on the TBird Ventilator Series. Improper installation of the Docking Bay can damage the ventilator and void the warranty.

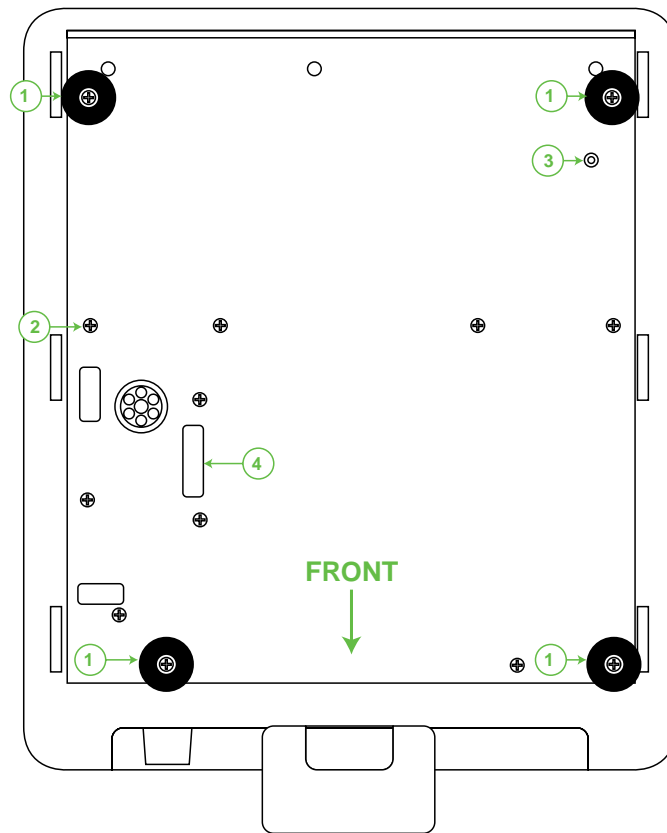

Figure 5-21. Ventilator Base

1. Remove the ventilator from external AC and ensure that the power switch is in the Standby position.
2. Turn the ventilator upside down and set it down on its top.
3. Referring to Figure 5-21, remove the following from the base of the ventilator:
 - Four (4) Rubber Bumpers – Ref. 1
 - Two (2) Screws– Ref. 2 & 3

- 4. Remove the external battery pack from the docking bay if installed.
- 5. Position the docking bay above the base of the ventilator.
- 6. Using the screw provided, attach the green/yellow wire with the ring terminal to the nut insert indicated in Figure 5-22, Ref. 1.

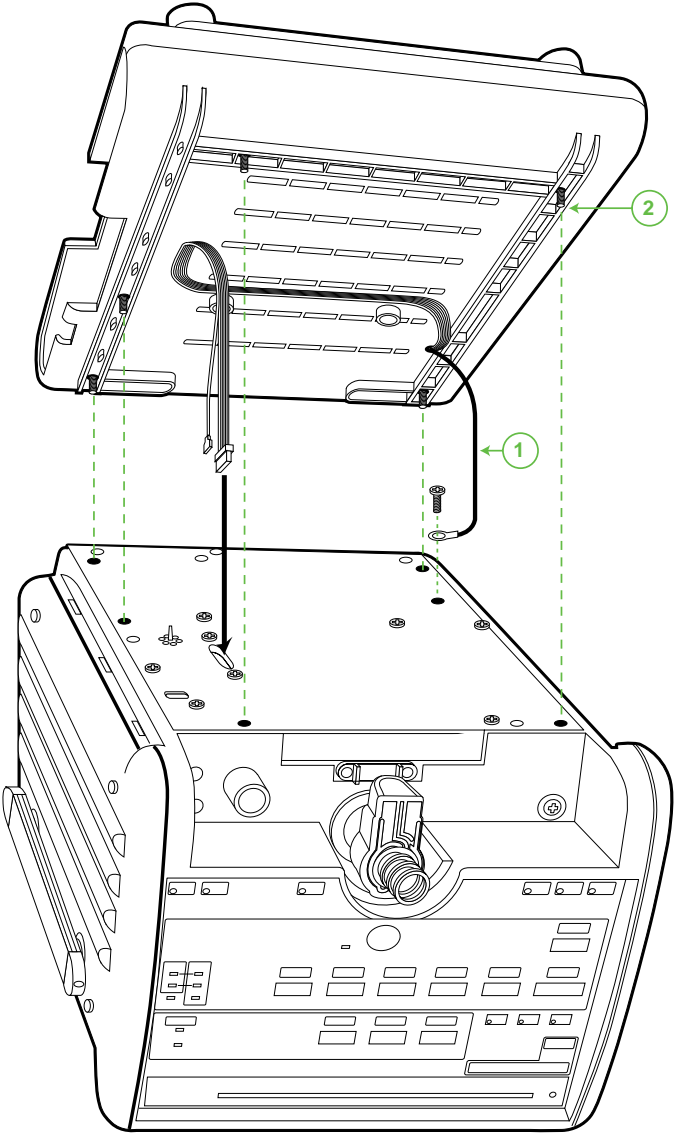

Figure 5-22. Docking Bay Assembly

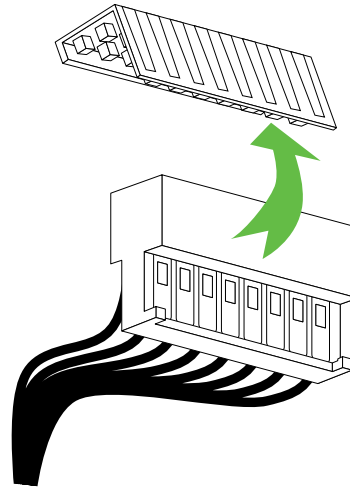

Figure 5-23. 8 Position Connector

7. Referring to Figure 5-23, remove the white plastic cover from the 8 position connector.
8. Starting with the 8 position connector, pass the cables from the docking bay through the slot in the base of the ventilator indicated in Figure 5-22.



CAUTION



When aligning the docking bay on the bottom of the ventilator, ensure that the cables are not pinched between the upper and lower mating surfaces.

- 9. Referring to Figure 5-22, align the captive retaining screws Ref. 2 with the mounting inserts where the rubber feet and screw Figure 5-21, Ref 2 were removed and tighten with the Phillips screwdriver.
- 10. Turn the ventilator back to the upright position.



CAUTION



The power supply of the ventilator is mounted to the side cover that is about to be removed. Pull it away from the ventilator slowly so as not to dislodge any electrical connections.

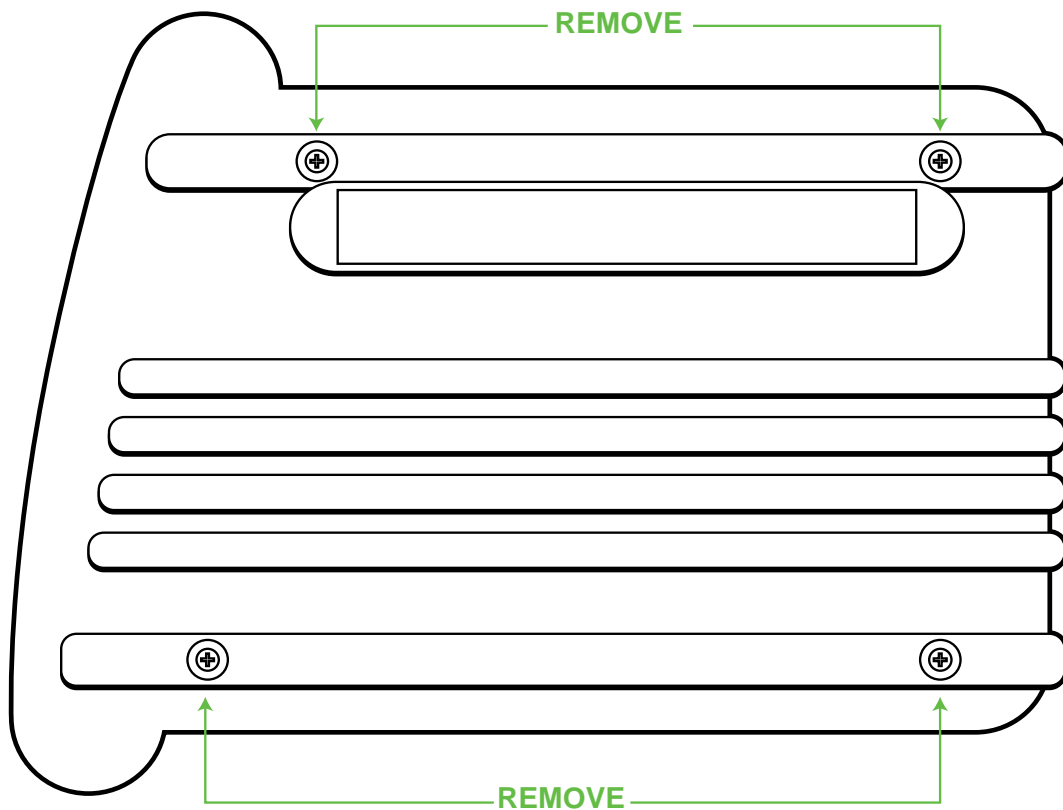

Figure 5-24. Right Side Cover

- 11. Remove the four (4) screws from the right side of the ventilator as shown in Figure 5-24.

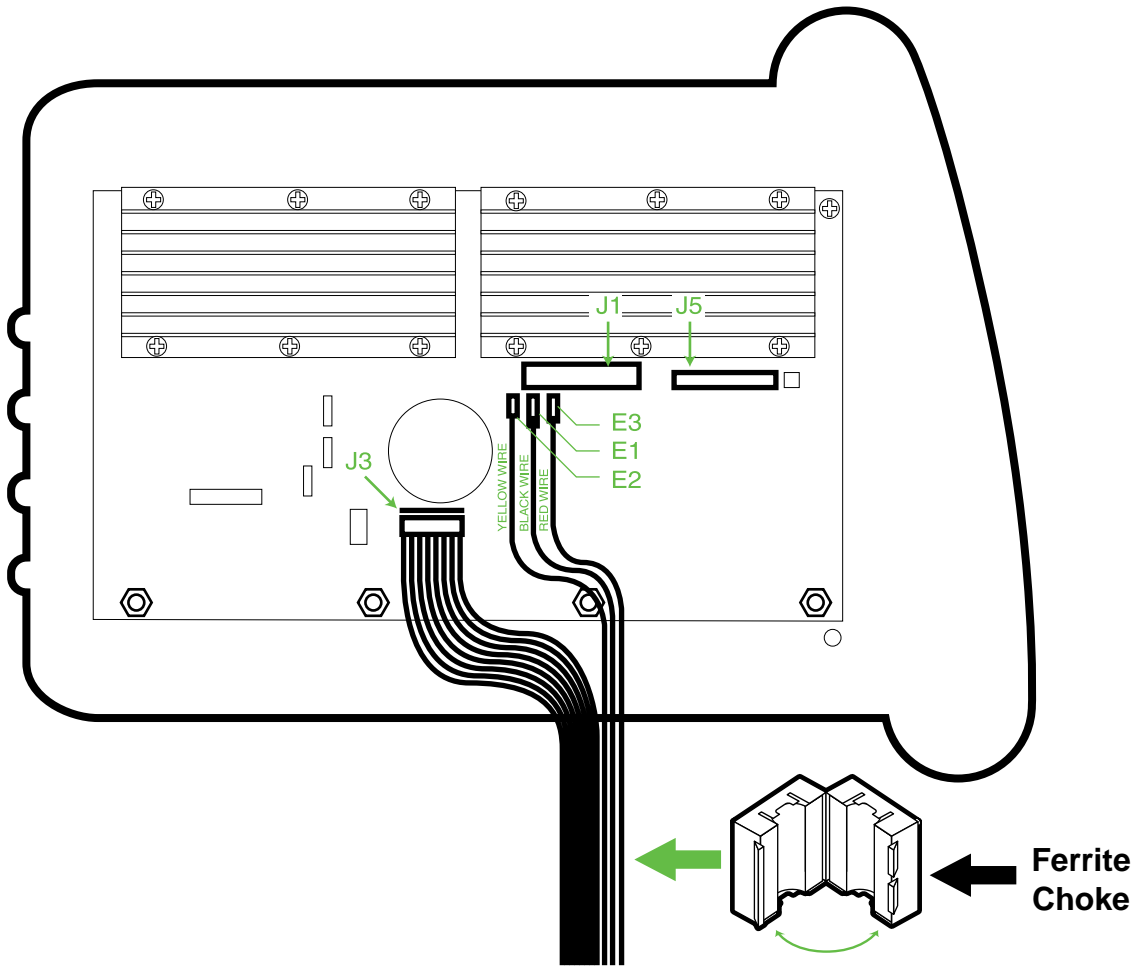

Figure 5-25. Power Supply PCBA

12. Remove connectors J5 and J1 from the power supply as indicated in Figure 5-25.
13. Un-snap the hinge on the Ferrite Choke provided with the docking bay and place it around the cables coming from the docking bay. Re-snap the hinge insuring that it is securely locked in place.
14. Replace the white cover onto the 8 position connector that was removed in step 6.

15. Move the right cover away from the ventilator and connect the cables coming from the docking bay to the power supply as indicated in Figure 5-25 and in accordance with the following:
 - The 8 position connector attaches to J3 with the locking tab in the upper position.
 - The black wire connects to terminal E1.
 - The yellow wire connects to terminal E2.
 - The red wire connects to terminal E3.
16. Connect the two harnesses to J1 and J5 that were previously removed.



CAUTION



Before assembling the ventilator, be sure to double check the alignment of connector J5. Misalignment of this connector can cause catastrophic damage to the Power Supply and/or the Main PCB.

17. Install the right side cover to the ventilator.
18. Install the external battery pack into the docking bay.
19. Plug the ventilator into AC power and verify that the charge indicators for both the internal battery and the external battery are illuminated (green or yellow).
20. Attach a patient circuit to the ventilator and turn it on.
21. Perform the checkout procedure as described in the TBird Operator's Manual.
22. Place the ventilator into Standby and allow the internal and external batteries to charge for approximately 11 hours.
23. Verify that both charge indicators are illuminated green after the 11 hour charge period.

Wire Harness and Cable Assemblies

 *Note*

Prior to removing a harness from the ventilator, it is advisable to label it first. Also note the connection points and the orientation of the locks or alignment key for proper installation. Refer to Table 5-1, below for further reference. Also, refer to the wiring diagram in the schematic section.

1. Remove the top and side covers from the ventilator.
2. Locate the harness to be removed and identify as required.
3. Unplug the ends or the cable or unplug one end of the cable and remove the attached hardware as required.
4. Refer to the following table for installation.

Table 5-1 - Wiring Connections

Part #	From	To
15027G	Rear Panel Alarm Loudness Control	Main PCBA J900
15489	Rear Panel Patient Assist Call Connector	Main PCBA J905
15490	Front Panel Encoder	Main PCBA J702
15492	Turbine Speed Encoder	Main PCBA J701
15493	Power Supply J1	Main PCBA J2
15494	Power Supply J5	Main PCBA J5
15497	Blender (TBird™ AVS and VSO ₂ Only)	Main PCBA J301
15499	Rear Panel Stand By/On Switch	Power Supply J7
15500	Rear Panel Fan	Power Supply J2
15501	Top Cover Harness	Power Supply J6 and Motor Controller PCBA P2
15507	Batteries and Energy Storage Capacitor	Harness 15501
15543	Line Fuse EL1 (Side Lug)	Power Supply EL1
15544	Neutral Fuse EL2 (Side Lug)	Power Supply EL2
15545	Rear Panel Ground Stud	Power Supply EE1
N/A	Turbine	Motor Controller PCBA P1
15584	EMI/RFI Filter (Case)	Rear Panel Ground Stud
15582	EMI/RFI Filter (Load)	Neutral Fuse EL2 (End Lug)
15583	EMI/RFI Filter (Load)	Line Fuse EL1 (End Lug)

INSERT CHAPTER 6 – SCHEMATICS HERE

CHAPTER 7 – PARTS LIST

What This Chapter Describes

This section of the TBird Ventilator Series Service Manual details the parts that are available for the repair of the ventilator.

It is intended for the Bird Factory trained bio-medical technician.

This section is composed in accordance with Bird's repair policy which excludes the following parts:

1. Any component soldered to PCB's
2. Component parts of electromechanical or pneumatic assemblies

If a part is not specifically included in this section, field repair is limited to the replacement of the next higher assembly containing this part.

Refer to the Removal & Replacement section of this manual for installation instructions.

After replacement of any part, a thorough check out of the ventilator is mandatory. This will verify that the original problem has been corrected and that no additional problems have been created by the repair process.

Base Assembly	7-6
Front Panel Assembly	7-3
Main PCB Assembly	7-11
Oxygen Blending Components	7-5
Power Supply PCB Assembly	7-12
Rear Panel Assembly	7-4
Right/Left Side Assembly	7-8
Top Cover Assembly	7-9
Turbine/Muffler Assembly	7-2
Wire Harnesses and Cable Assemblies	7-10

Turbine/Muffler Assembly

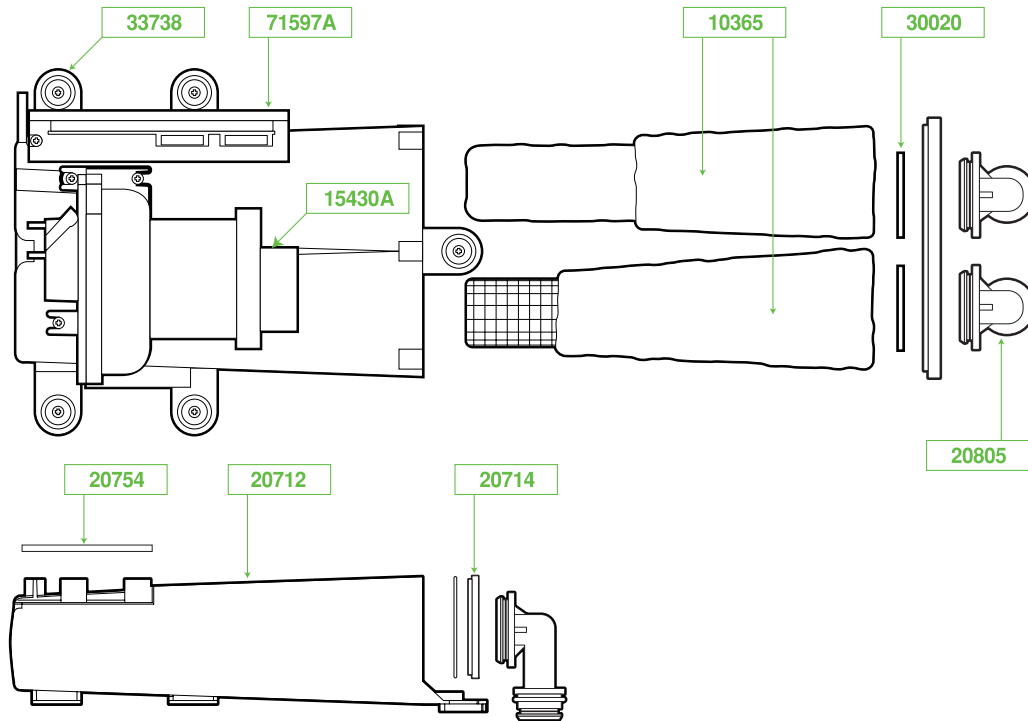

Figure 7-1. Turbine/Muffler Assembly

10365	• Muffler/Filter Core Assembly
15430A	• Turbine Assembly (Includes Turbine EEPROM and Harness)
20712	• Muffler Tube
20714	• Muffler Tube Cap
20754	• Turbine Base Gasket
20805	• 90 Degree Elbow
30020	• O-Ring
33738	• Isolator Grommet
71597A	• Motor Driver PCBA

Front Panel Assembly

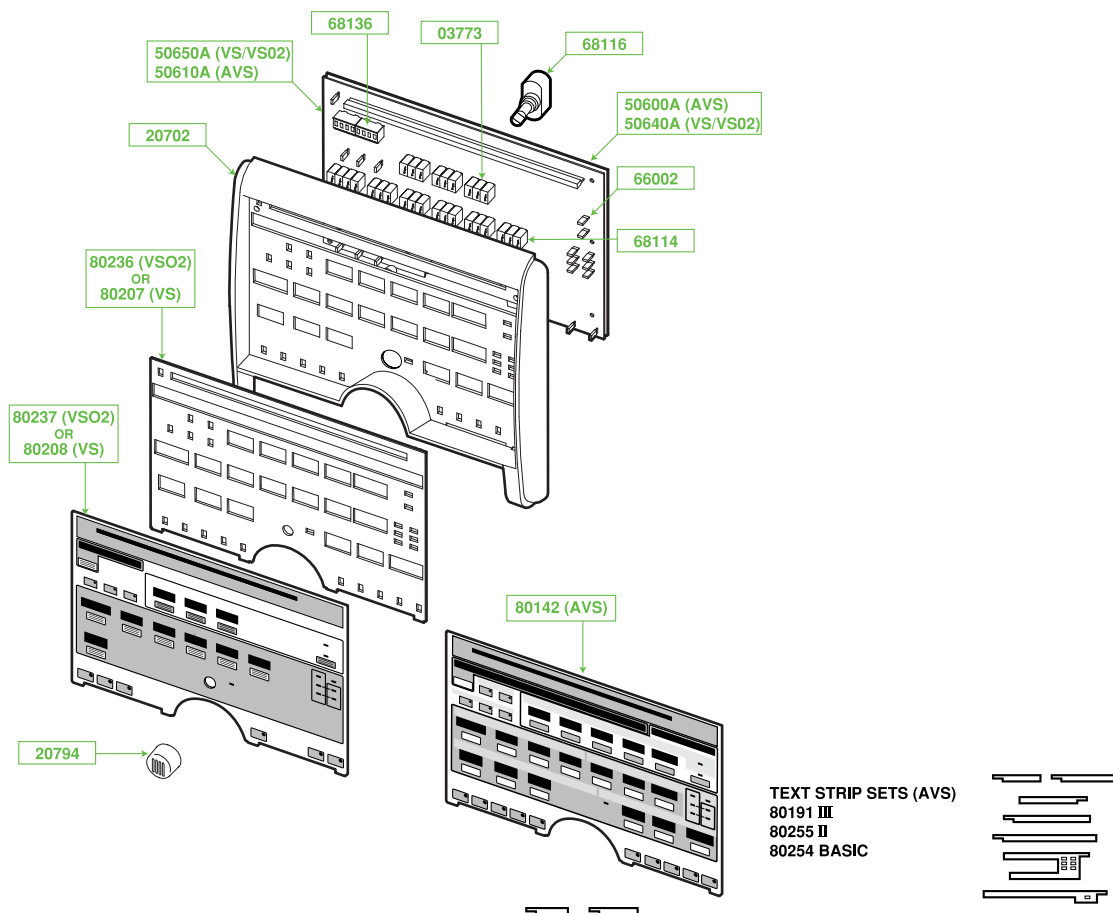

Figure 7-2. Front Panel Assembly

03773	7 Segment Display (Red)	68136	Dot Matrix Display
20702	Front Panel	80142	Control Panel (AVS)
20794	Control Knob	80191	Text Strips (AVS III)
50600A	Main PCBA (AVS)	80207	Control Panel, (TBird™ VS)
50610A	Display PCBA (AVS)	80208	Overlay, (TBird™ VS)
50640A	Main PCBA	80236	Control Panel, (TBird™ VSO ₂)
50650A	Display PCBA	80237	Overlay, (TBird™ VSO ₂)
66002	Rectangular Red LED (Vent Inop Only)	80254	Text Strips (AVS Basic)
68114	7 Segment Display (Yellow)	80255	Text Strips (AVS II)
68116	Optical Encoder		

PARTS LIST

Rear Panel Assembly

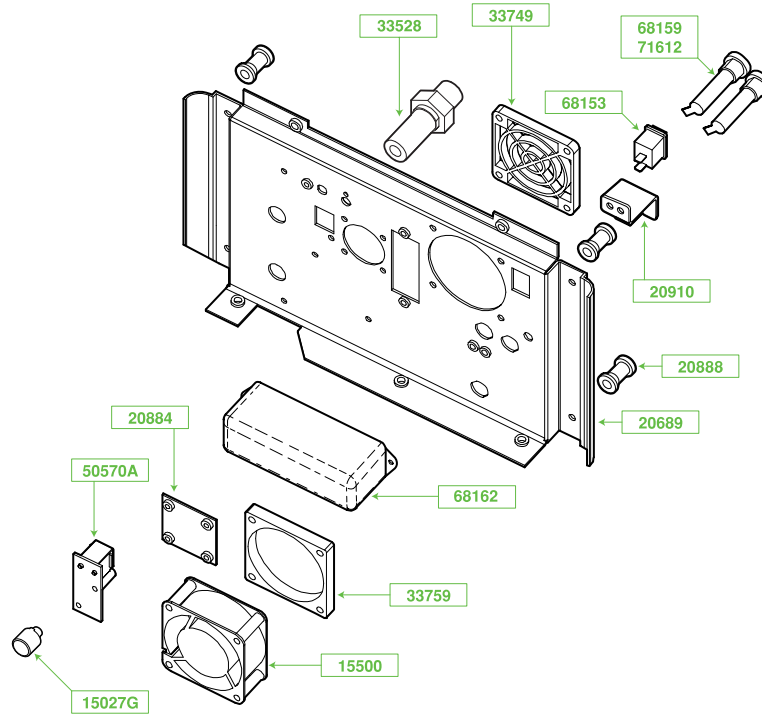

Figure 7-3. Rear Panel Assembly

15027G	Alarm Loudness Control (Includes Cable)
15500	Fan Assembly (Includes Cable)
68162	EMI/RFI Filter
20689	Rear Panel
20884	Cover Plate, Interface
33528	Optical Interface Connector (AVS only)
33749	Fan Air Filter w/ Grill
33759	Fan EMI Filter
50570A	Patient Assist Call PCB
68153	Stand By/On Switch
68159	Fuse Holder (two required)
71612	Fuse, 3.15 A (two required)
20946	Power Cord (Not Shown)
20888	Cord Wrap (four required)

Oxygen Blending Components

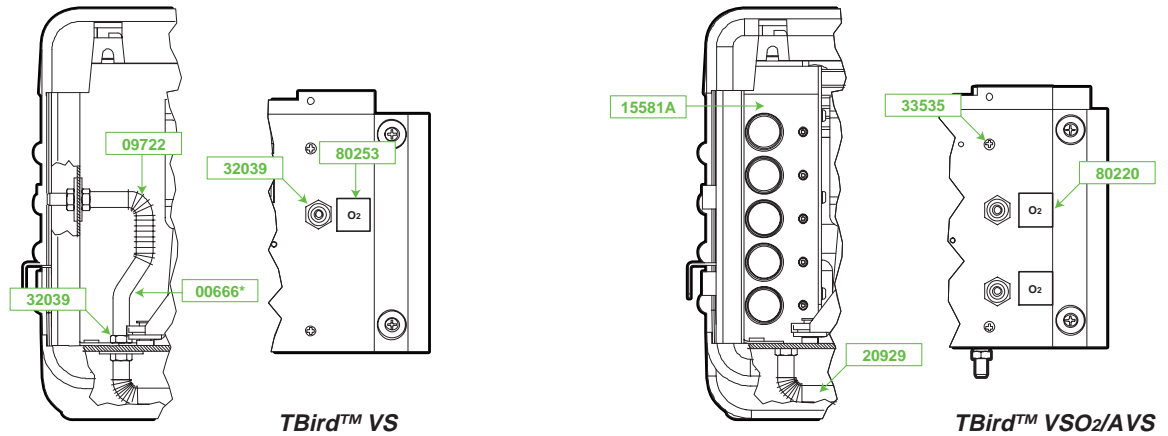

Figure 7-4. Oxygen Blending Components

00666*	1/4" ID Green Tubing (50 ft Bulk Only) (TBird VS)
09722	Spring
15581A	Blender Assembly
20929	O ₂ Bleed Tube
32039	Bulkhead Fitting
33535	Isolation Grommet (TBird VSO ₂ /AVS)
33772	Plug (TBird VS)
80220	Label (TBird VSO ₂ /AVS)
80253	Label (TBird VS)

*50 ft. bulk only

PARTS LIST

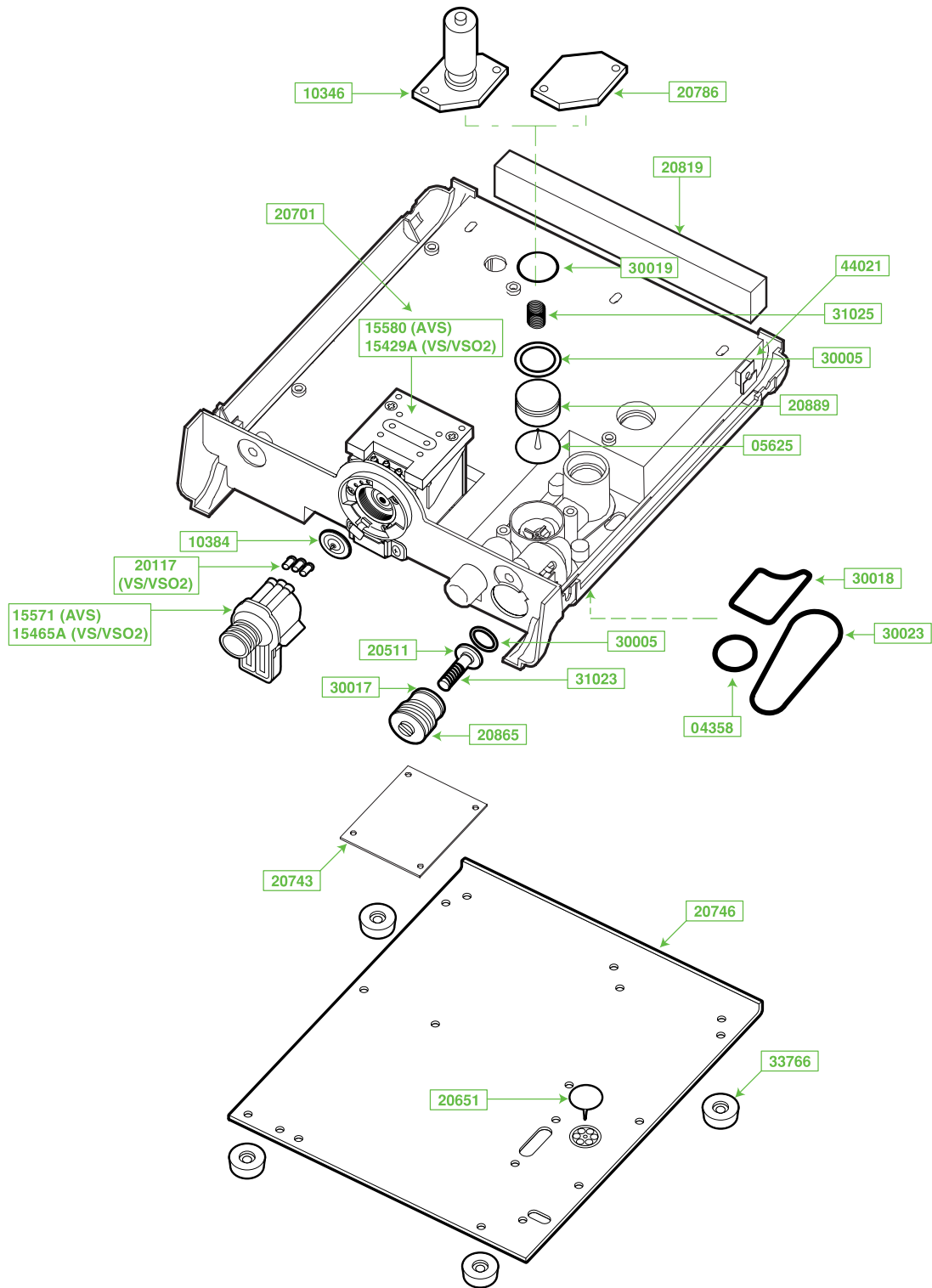

Figure 7-5. Base Assembly

Base Assembly

04358	O-Ring (Baseplate, .737" ID)
10384D	Exhalation Diaphragm/Poppet Assembly (10 pack)
15429A	Exhalation Valve
15465A	Exhalation Body/Flow Sensor Assembly (VS/VSO ₂)
20117	Barrel Seal
20511	Poppet
20743	Heating Duct Cover
20746	Baseplate
20819	Rear Inlet Filter
20865	Relief Valve Adjuster
30005	O-Ring, (Relief Valve Poppet)
30017	O-Ring, (Relief Valve Adjuster)
31023	Spring
30018	O-Ring (Baseplate, 2.3" ID)
30023	O-Ring (Baseplate, 1.612" ID)
33766	Rubber Bumper
44021	"U" Nut
20701	Base
15580A	Exhalation Valve (AVS)
15571A	Exhalation Body/Flow Sensor Assembly (AVS)
10346	Inspiratory Hold Solenoid
20786	Cover Inspiratory Hold
20651	Valve ¹³ / ₁₆ " Umbrella
05625	Valve 1.0" Umbrella
20889	Piston Inspiratory Valve
31025	Spring
30019	O-Ring

PARTS LIST

Right/Left Side Assembly

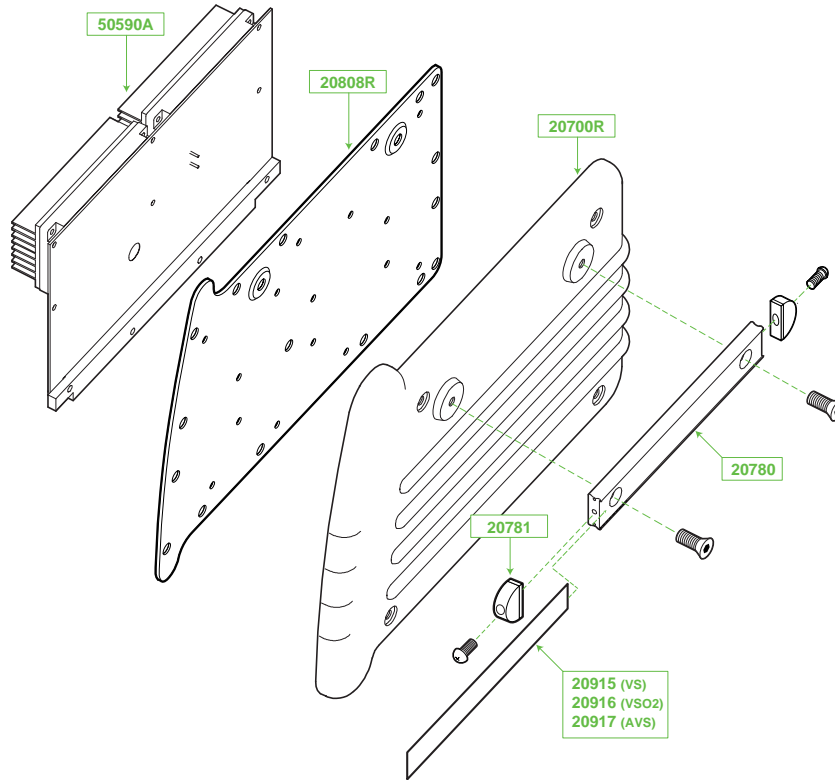

Figure 7-6. Right/Left Side Assembly

20700L	●	Left Side Panel (Not shown)
20700R	●	Right Side Panel
20780	●	Side Rail
20781	●	Rail End Cap
20808L	●	Left Side Panel Insert (Not Shown)
20808R	●	Right Side Panel Insert
20915	●	Side Rail Insert (VS)
20916	●	Side Rail Insert (VSO ₂)
20917	●	Side Rail Inserts (AVS)
50590A	●	Power Supply PCBA

Top Cover Assembly

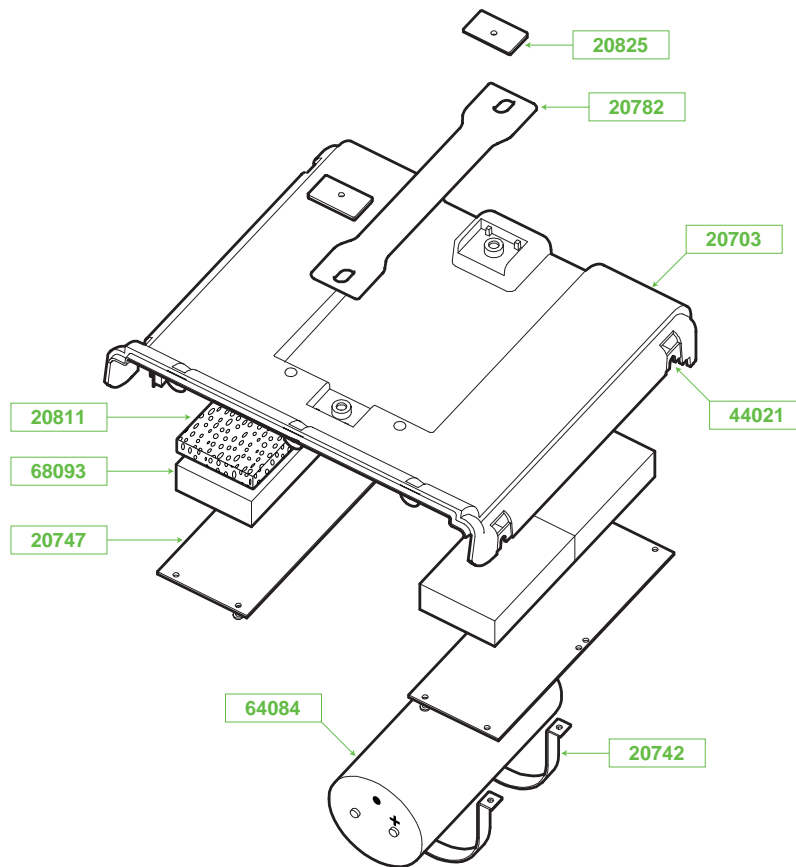

Figure 7-7. Top Cover Assembly

20703	• Ventilator Top Cover
20742	• Capacitor Bracket
20747	• Battery Cover
20782	• Handle
20811	• Foam Pad
20825	• Handle Retainer
44021	• "U" Nut
64084	• Capacitor
68093	• Battery, 12 Vdc, .3 Ah
80228	• Label, 12Vdc, .3Ah Battery (Not Shown)

Wire Harness and Cable Assemblies

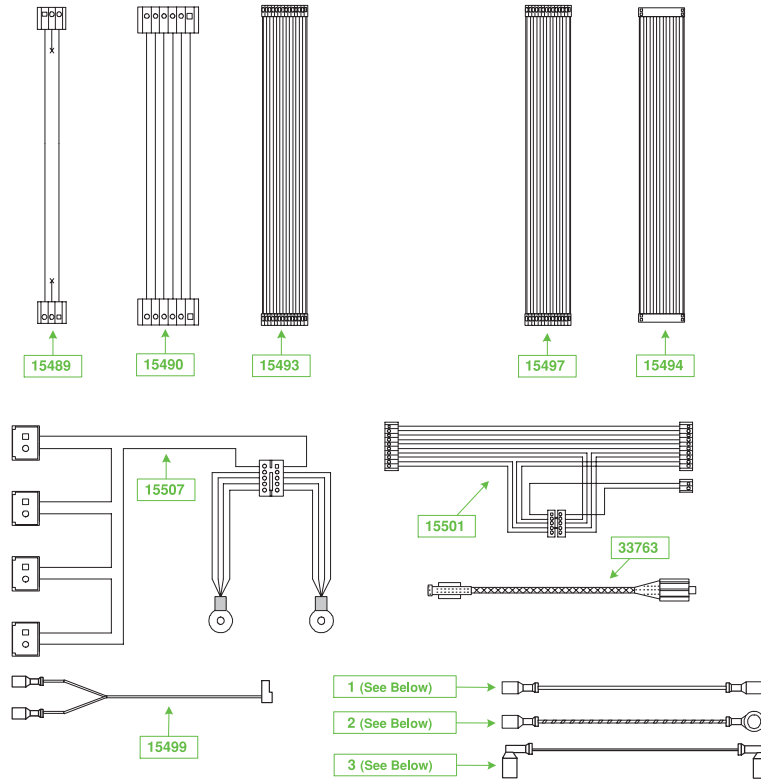

Figure 7-8. Wire Harnesses and Cable Assemblies

15489	● Patient Assist Call Cable Assembly
15490	● Panel Encoder Cable Assembly
15493	● Main/Power I Cable Assembly
15494	● Main Power II Cable Assembly
15497	● Main/Blender Cable Assembly (VSO ₂ /AVS Only)
15499	● On/Standby Cable
15501	● Motor Driver Cable Assembly
15507	● Top Cover Cable Assembly
15543	● ⑩ Cable Assembly, Line Fuse, Black
15544	● ⑩ Cable Assembly, Neutral Fuse, White
15545	● ④ Cable Assembly, Ground, Power Supply, Green/Yellow
15582	● ① Cable Assembly, Line, Fuse Filter
15583	● ① Cable Assembly, Neutral, Line Filter
15584	● ① Cable Assembly, Ground, Line Filter
33763	● Gas Dryer

Main PCB Assembly

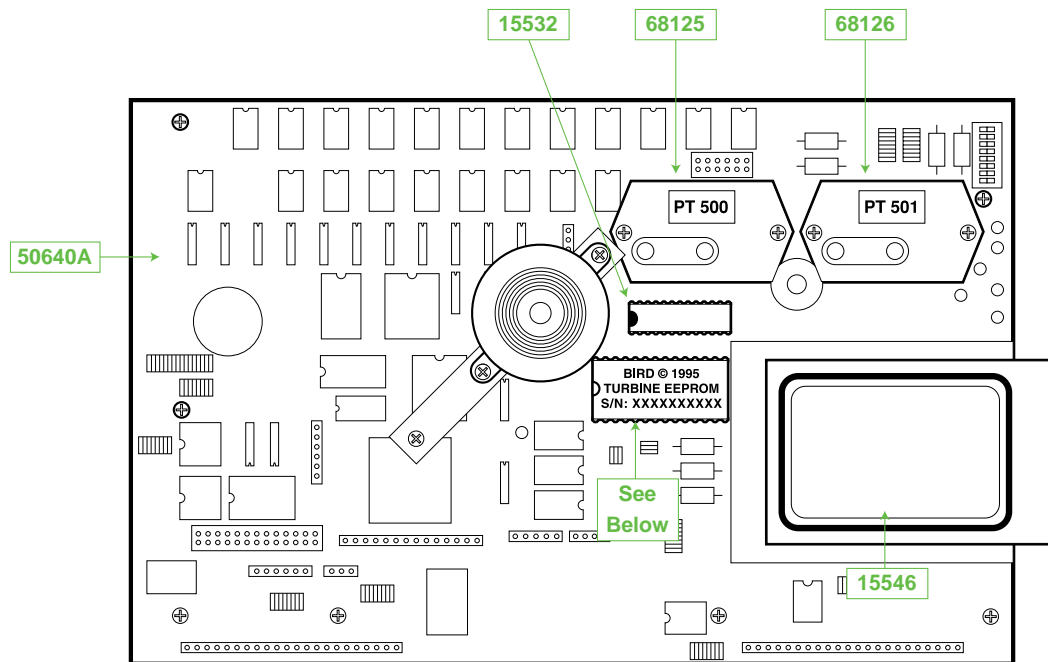

Figure 7-9. Main PCB Assembly

N/A	• Turbine Calibration EEPROM(Sold only with Turbine Assy 15430)
15532	• Programmed Watch Dog PAL
15546	• Program Memory Card
68125	• Turbine Differential Pressure Transducer
68126	• Exhalation Differential Pressure Transducer
50600A	• Main PCBA (AVS)
50640A	• Main PCBA (VS / VSO ₂)

Power Supply PCB Assembly

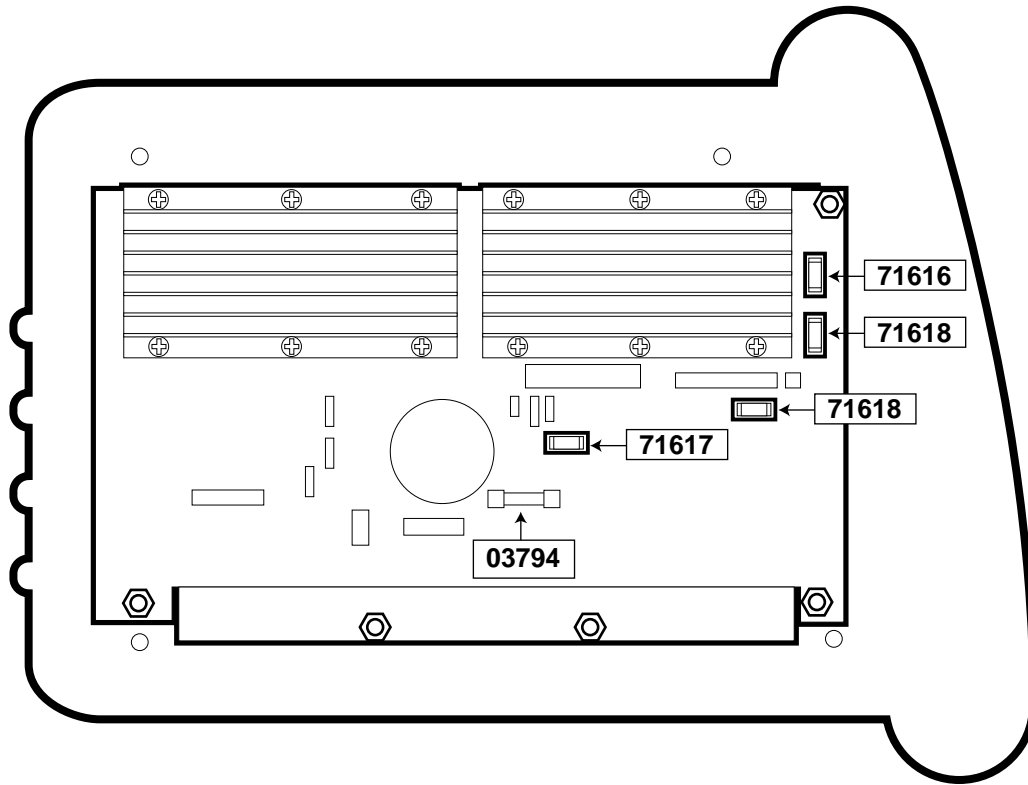

Figure 7-10. Power Supply PCB Assembly

03794	●	Fuse, F401, 5A, SB, 5x20 mm
50590A	●	Power Supply PCBA
71616	●	Fuse, F402, 1A, SB, SMT
71617	●	Fuse, F603, 2.5A, SB, SMT
71618	●	Fuse, F601 & F602, 3.5A, SB, SMT

INDEX

- 500 Hour Maintenance 2-1, 2-2
 - 5,000 Hour Maintenance 2-1, 2-2
 - 20,000 Hour Maintenance 2-1, 2-3
 - 7 Segment Display, Red 5-17
 - 7 Segment Display, Yellow 5-17
 - 8 Position Connector 5-30
- A —
- Alarm Loudness Potentiometer 5-24
 - Anti-Suffocation Valve 5-26
 - Apnea 4-2
 - Assist Call, Patient 5-23, 6-42
 - Auto-Triggering 4-15
- B —
- Base 5-28, 7-6
 - Base Plate O-Rings 5-26
 - Battery Charger, Schematic 6-41
 - Battery Charge Indicators 4-15
 - Batteries, Internal 5-10
 - Battery On 4-2
 - Blender 4-13, 5-21, 6-40
 - Blending Components 7-5
 - Block Diagram 6-2 thru 6-16
- C —
- Cable, Turbine 5-20
 - Cable, Wire 5-34, 7-10
 - Calibration, Airway Pressure Transducer 3-6, 3-8
 - Calibration, Exhalation Differential Transducer 3-9
 - Calibration, Oxygen Pressure Transducer 3-9
 - Calibration, Turbine Differential Transducer 3-9
 - Capacitor, Energy Storage 5-10
 - Check Bkup 4-2
 - Check Events 4-2
 - Circ Fault 4-3
 - Configuration Memory Card 5-6
 - Cover, Left Side 5-3, 5-8, 7-8
 - Control Panel 5-15
 - Cover, Protective 5-8
 - Cover, Right Side 5-4, 5-8, 5-31, 7-8
 - Cover, Top 5-5, 7-9
- D —
- Defaults 4-3
 - Delivered Volumes 4-14
 - Display, 7 Segment Red 5-17
 - Display, 7 Segment Yellow 5-17
 - Display, Dot Matrix 5-17
 - Display, PCBA 5-15
 - Display, PCBA, Schematics 6-36 thru 6-39
 - Docking Bay, Assembly 5-29
- DPRAM 1 4-3
 - DPRAM 2 4-3
- E —
- EEPROM Fault 4-3
 - EEPROM, Turbine 5-20
 - Electrical, Hazards, Precautions 5-1
 - EMI, Fan Filter 5-22, 5-24
 - Encoder, Panel 5-15
 - Energy Storage Capacitor 5-10
 - Environmental, Event Detection Codes 4-11
 - Event Detection Codes 4-11
 - Event Detection Codes, Environmental 4-11
 - Event Detection Codes, Hardware 4-12
 - Event Detection Codes, Software 4-12
 - Event Detection Codes, System 4-11
 - Exhalation Differential Transducer Calibration 3-9
 - Exhalation Differential Pressure 5-25
 - Exhalation Valve 5-19
 - External Battery 4-3
 - External Battery Charger, Schematic 6-41
 - External Docking Bay 5-29
- F —
- Fan, EMI Filter 5-22
 - Fan, Inlet Filter 5-22
 - Fan Fault 4-4
 - Filter 4-4, 5-24
 - Filter Core, Muffler 5-18
 - Flash Update 4-4
 - Flow Cal 4-5
 - Flow Sensor 4-5
 - Front Panel 5-14, 5-15, 7-3
 - Fuse Holder 5-24
- H —
- Hardware, Event Detection Codes 4-12
 - Harness, Wire 5-34, 7-10
 - High PEEP 4-6
 - High Pres (Alarm) 4-6
 - HW Fault 4-7
 - High O2 4-6
- I —
- Inlet, Fan Filter 5-22
 - Internal Batteries 5-10
 - IOP (CPU, Timer & RAM) 4-7
 - IOP DPRAM 4-7
 - IOP XRAM 4-7

- K —
- Keys 4-15
- L —
- LED 5-17
- Left Side Cover 5-3, 5-7, 7-8
- Limited (Alert) 4-7
- Locked (Alert) 4-8
- Low Battery 4-8
- Low O₂ 4-8
- Low Pres (Alarm) 4-8
- Low Volume (Alarm) 4-9
- M —
- Main PCBA 3-2, 5-15, 7-11
- Main PCBA, Schematic 6-23 thru 6-35
- Maintenance, 500 Hour 2-2
- Maintenance, 2,000 hour 2-3
- Maintenance, 5,000 hour 2-2
- Maintenance, 20,000 hour 2-4
- Maintenance, schedule 2-1
- Malfunctions, Auto-Triggering 4-14
- Malfunctions, Battery Charge Indicators 4-15
- Malfunctions, Blender 4-13
- Malfunctions, Delivered Volumes 4-14
- Malfunctions, General 4-13
- Malfunctions, Keys 4-15
- Malfunctions, Monitored Exhaled Volumes 4-13, 4-14
- Malfunctions, ON Indicator 4-15
- Malfunctions, Oxygen Concentrations 4-13
- Malfunctions, Peak Flow 4-15
- Malfunctions, Pressure Alarms 4-15
- Malfunctions, Sensitivity 4-14
- Memory Card, Program 5-6
- Messages 4-1
- Message, Apnea 4-2
- Message, Battery On 4-2
- Message, Check Bkup 4-2
- Message, Check Events 4-2
- Message, Circ Fault 4-3
- Message, Defaults 4-3
- Message, DPRAM 1 4-3
- Message, DPRAM 2 4-3
- Message, EEPROM Fault 4-3
- Message, Ext Battery 4-3
- Message, Fan Fault 4-4
- Message, Filter 4-4
- Message, Flash Update 4-4
- Message, Flow Cal 4-5
- Message, Flow Sensor 4-5
- Message, HW Fault 4-7
- Message, High O₂ 4-6
- Message, High PEEP 4-6
- Message, High Pres (Alarm) 4-6
- Message, IOP (CPU, Timer & RAM) 4-7
- Message, IOP DPRAM 4-7
- Message, IOP XRAM 4-7
- Message, Limited (Alert) 4-7
- Message, Locked (Alert) 4-8
- Message, Low Battery 4-8
- Message, Low O₂ 4-8
- Message, Low Pres (Alarm) 4-8
- Message, Low Volume (Alarm) 4-9
- Message, New Sensor 4-9
- Message, No Cal Data 4-9
- Message, Power Up 4-9
- Message, Release IOP 4-9
- Message, Remote Fault 4-9
- Message, ROM 1 4-9
- Message, SRAM 4-10
- Message, Timer 4-10
- Message, Turbine ROM 4-10
- Message, Watchdog Pal 4-10
- Message, XDCR Fault 4-10
- Monitored Exhaled Volumes 4-13, 4-14
- Monitor Window, Messages 4-1
- Motor Controller 5-12
- Muffler 7-2
- Muffler, Filter Core 5-18
- N —
- New Sensor 4-9
- No Cal Data 4-9
- O —
- ON Indicator 4-15
- ON Switch 5-24
- O-Rings 5-26
- Outlet Check Valve 5-27
- Overlay 5-15, 7-3
- Oxygen, Blending Components 7-5
- Oxygen Concentrations 4-13
- Oxygen Sources, required 1-2
- Oxygen Pressure Transducer Calibration 3-9
- P —
- Panel, Control 5-15
- Panel Encoder 5-15
- Panel, Front 5-14, 7-3
- Panel, Rear 7-4
- Patient Assist Call 5-23, 6-42
- Parts List 7-1
- PCBA, Battery Charger 6-41
- PCBA, Blender 6-40
- PCBA, Display 5-15, 6-36 thru 6-39
- PCBA, Main 5-15, 6-23 thru 6-35, 7-11

PCBA, Motor Controller 5-12
 PCBA, Power Supply 5-32, 6-17, 7-12
 Peak Flow 4-15
 Power Supply, Assembly 7-12
 Power Supply, Removal 5-9
 Power Supply, Schematic 6-17 thru 6-22
 Power Supply, Voltage Check 4-17
 Power Up 4-9
 Power, required 1-2
 Pressure Alarms 4-15
 Program Memory Card 5-6
 Protective Side Covers 5-8

— R —

Rear Panel 7-4
 Release IOP 4-9
 Relief Valve 5-27
 Remote Fault 4-9
 Replacement Components,
 maintenance 2-4
 Right Side Cover 5-4, 5-31, 7-8
 ROM 1 4-9

— S —

Sensitivity 4-14
 Side Cover, Left 5-3
 Side Cover, Right 5-4, 5-31, 7-8
 Socketed LED 5-17
 Software, Event Detection Codes 4-11
 Solenoid Test 3-5
 Special Functions 3-3
 SRAM 4-10
 Standby 5-24
 SVT (Service Verification Test) 3-1, 3-5
 SVT, Manual Turbine Control 3-1
 SVT, Manual Solenoid Control 3-1
 SVT, Transducer Calibration 3-1, 3-7,
 3-9
 SVT, Watch Dog Test 3-2
 Switch, Standby/On 5-24
 System, Event Detection Codes 4-11

— T —

Text Strip Sets 5-14, 7-3
 Tools, required 1-1, 5-1
 Top Cover 5-5, 7-9
 Transducer, Turbine Differential
 Pressure 5-25
 Transducer, Exhalation Differential
 Pressure 5-25
 Troubleshooting, Apnea 4-2
 Troubleshooting, Battery On 4-2
 Troubleshooting, Check Bkup 4-2
 Troubleshooting, Check Events 4-2
 Troubleshooting, Circ Fault 4-3
 Troubleshooting, Defaults 4-3

Troubleshooting, DPRAM 1 4-3
 Troubleshooting, DPRAM 2 4-3
 Troubleshooting, EEPROM Fault 4-3
 Troubleshooting, Ext Battery 4-3
 Troubleshooting, Fan Fault 4-4
 Troubleshooting, Filter 4-4
 Troubleshooting, Flash Update 4-4
 Troubleshooting, Flow Cal 4-5
 Troubleshooting, Flow Sensor 4-5
 Troubleshooting, High O2 4-6
 Troubleshooting, High PEEP 4-6
 Troubleshooting, High Pres (Alarm) 4-6
 Troubleshooting, HW Fault 4-7
 Troubleshooting, IOP (CPU, Timer & RAM)
 4-7
 Troubleshooting, IOP DPRAM 4-7
 Troubleshooting, IOP XRAM 4-7
 Troubleshooting, IOP XROM 4-7
 Troubleshooting, Limited (Alert) 4-7
 Troubleshooting, Locked (Alert) 4-8
 Troubleshooting, Low Battery 4-8
 Troubleshooting, Low O2 4-8
 Troubleshooting, Low Pres (Alarm) 4-8
 Troubleshooting, Low Volume (Alarm) 4-9
 Troubleshooting, No Cal Data 4-9
 Troubleshooting, New Sensor 4-9
 Troubleshooting, Power Up 4-9
 Troubleshooting, Release IOP 4-9
 Troubleshooting, Remote Fault 4-9
 Troubleshooting, ROM 1 4-10
 Troubleshooting, SRAM 4-10
 Troubleshooting, Timer 4-10
 Troubleshooting, Turbine ROM 4-10
 Troubleshooting, Watchdog Pal 4-10
 Troubleshooting, XDCR Fault 4-10
 Turbine, Assembly 5-20, 7-2
 Turbine, EEPROM and Cable 5-20
 Turbine Differential Pressure, Calibration
 3-8
 Turbine Differential Pressure Transducer
 5-25
 Turbine, Serial Number 3-2, 3-10

— V —

Valve, Anti-suffocation 5-26
 Valve, Exhalation 5-19
 Valve, Outlet Check 5-27
 Valve, Relief 5-27
 Voltage Check 4-17

— W —

Watch Dog, PAL 5-13
 Watch Dog, Test 3-10
 Window Messages, Monitor 4-1
 Wire Harness and Cable 5-34, 7-10
 Wiring, Pneumatic 6-1



This page intentionally left blank.



NO POSTAGE
NECESSARY
IF MAILED
IN THE
UNITED STATES

BUSINESS REPLY MAIL
FIRST CLASS PERMIT NO. 509 PALM SPRINGS, CA

POSTAGE WILL BE PAID BY ADDRESSEE

BIRD PRODUCTS CORPORATION
Attention: Tech Service Department
1100 Bird Center Drive
Palm Springs, CA 92262

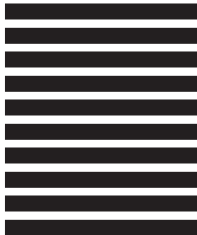

**TBird® Ventilator Series Service Manual,
L1314 Rev. B, Reply Card**

If you would like to receive future updated material for this manual, please fill out and return this card to Bird Products Corporation. Thank you.

Company: _____

Name: _____

Title: _____

Address: _____

Zip: _____ Telephone: _____

Date Manual was received: _____