

# Evaporative Humidifier/Cooler FA6 for AHU's

## Technical manual

FA6

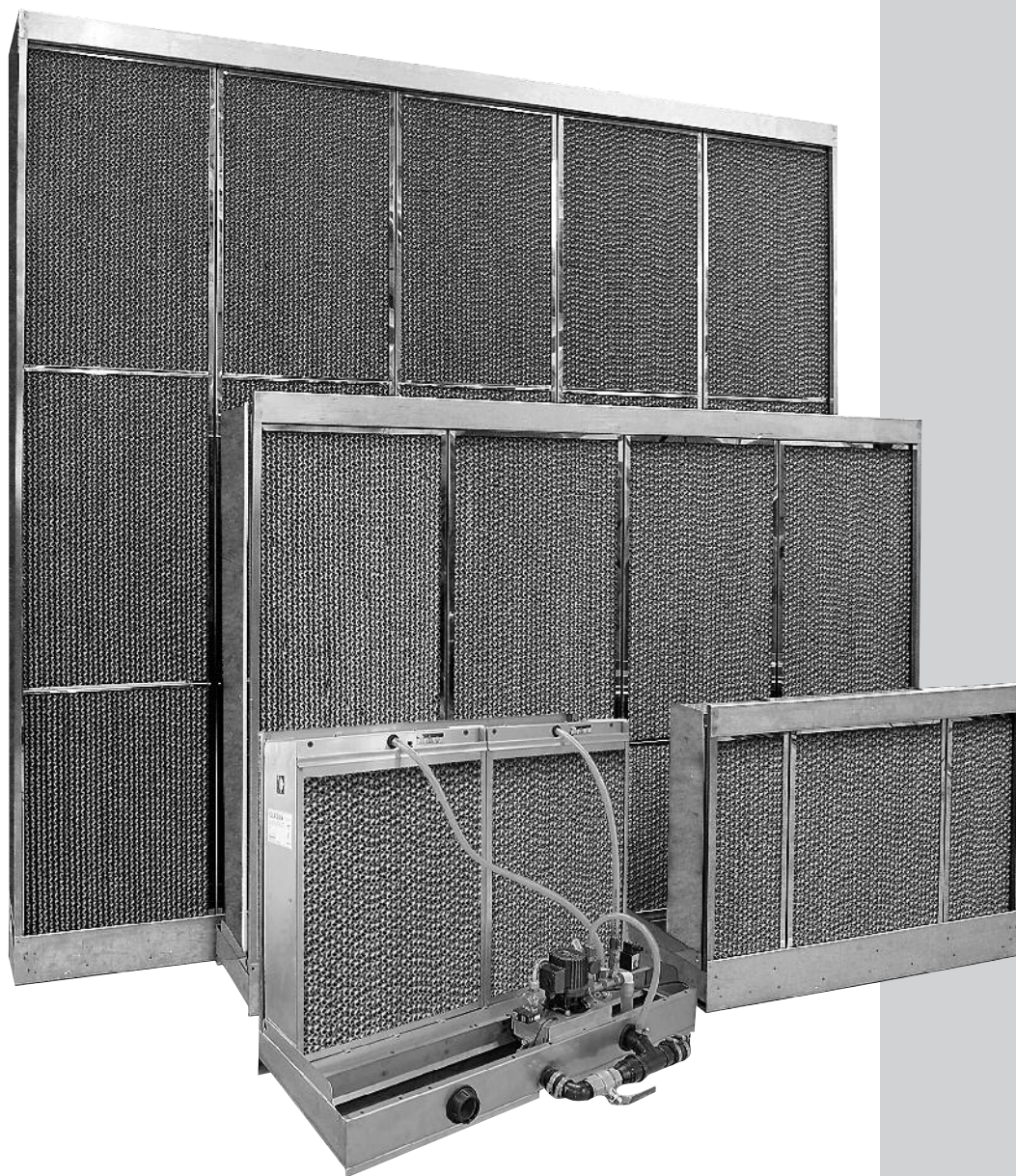

**Disclaimer**

Munters reserves the right to make alterations to specifications, quantities, dimensions etc. for production or other reasons, subsequent to publication.

The information contained herein has been prepared by qualified experts within Munters.

While we believe the information is accurate and complete, we make no warranty or representation for any particular purposes. The information is offered in good faith and with the understanding that any use of the units or accessories in breach of the directions and warnings in this document is at the sole discretion and risk of the user.

This manual has been prepared in English as original language.

# Contents

<b>FA6 Evaporative humidifier/Cooler Introduction</b>	<b>4</b>
Introduction	4
Technology basics	5
Standard sizes	5
Simple to install	5
Technical specification	6
<b>Design and operation</b>	<b>7</b>
Circulating-water models	7
Bleed-off flow	8
<b>Control system</b>	<b>9</b>
On/off control	
Step control	10
Face and by-pass control	10
Dew-point control	11
Options	11
<b>BMS integration and improved hygiene</b>	<b>12</b>
FA6 Clean Concept	
FA6 Dosing System	
FA6 UV sterilization system	
FA6cs Conductivity System	
<b>Dimensioning</b>	<b>12</b>
How to select your FA6	
Size selection program	
Dimensioning example	
<b>Charts for Humidifier sizing</b>	<b>13–14</b>
Dimensions, weight and pump sizes	15
<b>Water quality / data</b>	<b>16</b>
Table and example	16
Water from other sources	16
Total water consumption for direct-supply-water model – table	16
Pressure requirements at water supply connection point without CC unit	17
<b>Water consumption</b>	<b>18</b>
Direct water model	
Circulating water model	
Bleed-off factor	
Example	
<b>Water quality</b>	<b>18</b>
Water from other sources	
General water hardness conversion table	
<b>Ordering key</b>	<b>19</b>
<b>Design standards, approvals and certifications</b>	<b>19</b>

# FA6 Evaporative humidifier/cooler

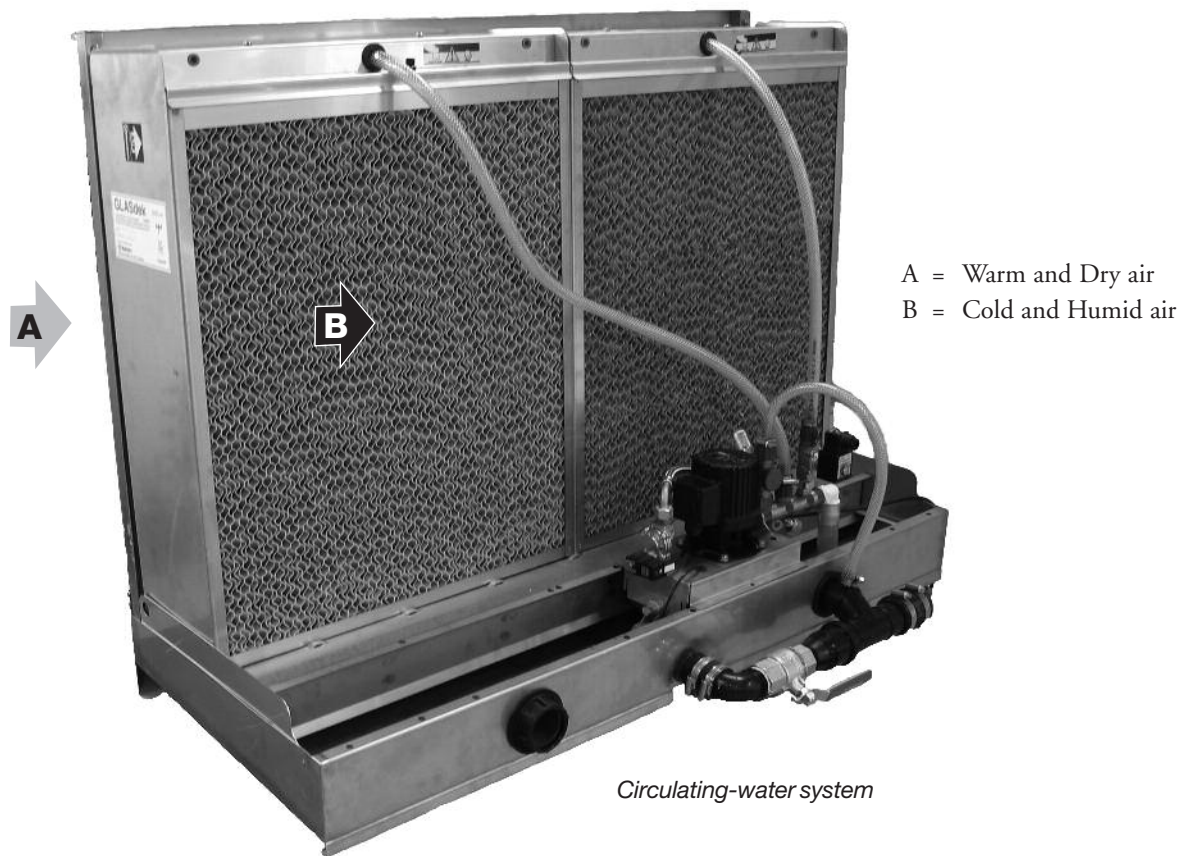

## Introduction

The Munters evaporative FA6 humidifier/cooler has been specially designed for integration into air-handling units within both residential and industrial buildings. The design is compact and sizes conform to all typical air handling units (AHU). The standard product line encompasses a wide range of sizes, options, for multistage control integrated droplet separator and three nominal humidity efficiencies of 65%, 85%, 95%.

There are also two different models for either direct water or circulating water. The airflow range is between 0.5 and 34 m<sup>3</sup>/s. The external dimensions of the smallest humidifier are 0.6 x 0.6 m; the largest 3x3 m. The recommended air velocity through the media is up to 3.5 m/s without the droplet separator (DropSTOP), and up to 4.5 m/s with Dropstop™.

- Air-flow range, 0.5–34 m<sup>3</sup>/s
- Nominal humidification efficiency: 65%, 85% and 95%
- Humidifier cassettes of non combustible GLASdek®
- Designed with circulation or direct water systems
- With or without droplet separator, DropSTOP™
- Adapted for dew-point, stepped, face and by-pass control, or On-Off control
- Complete emptying of bottom tray
- Simple maintenance
- Comprehensive accessories available.

# Technology basics

The heart of FA6 is a cassette made from inorganic non combustible evaporative media – GLASdek®. Water is supplied to the top of the GLASdek evaporative media via a distribution header. The water flows down the corrugated surface of the media. As the warm and dry air passes through the media it evaporates a proportion of the water and thus produces cold, humidified air. The rest of the water assists in washing the media, and is drained back to the tray. The energy that is needed for the evaporation is taken from the air itself. The air that leaves the humidifier is therefore humidified and cooled simultaneously without any external energy supply for the evaporation. This is in essence the adiabatic cooling process. It is very efficient and the consumption of energy is very low. It also allows the use of water straight from the tap with no need for water treatment (i.e. demineralisation plants). Minerals and pollutants stay behind in the GLASdek evaporative media to be washed away with the discharge water keeping the total humidification process pure.

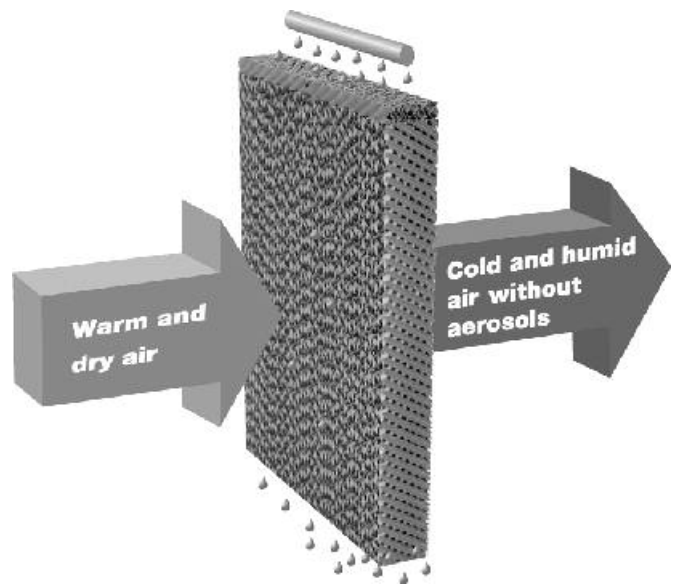

The principle of evaporative humidification and cooling (the adiabatic cooling process).

## Standard sizes

### Wide range of sizes

FA6 comes in a wide range of standard sizes that conform to all typical air handling unit dimensions. The individual units cover air volumes from 0.5-34 m<sup>3</sup>/s.

For very large air volumes a combination of units is selected in order to achieve the desired size. Non-standard sizes are available upon request. Selecting the optimal size is easy with the FA6 Dimensioning Program or your Munters contact person can help you.

### Simple to install

The FA6 is easy to install and easy to configure into both existing and new HVAC systems. For installation you need to have access to electricity (400V/50 Hz) and (230V/50 Hz) as standard for pump and solenoid valves. Pump for (230V/50 Hz) or (120V/60 Hz) and solenoid valves for (24V AC) are available as option.

Water supply (1-10 bar) and drainage (Ø 50 mm/2"). Connect to existing BMS/control system or Munters can supply a new control system for the control of humidifier/cooler. Due to its high performance and compact design it is the ideal replacement for older, less efficient humidifiers/coolers.

A, width [cm]	B, height [cm]								
	60	90	120	150	180	210	240	270	300
60	0.9	1.6	2.4						
90	1.2	2.3	3.4		Air volume [m <sup>3</sup> /s at 4.5 m/s]				
120	1.7	3.2	4.7						
150		3.9	5.8	7.6	9.5	11.3	13.2		
180		4.8	7.1	9.3	11.6	13.8	16.0		
210			8.1	10.7	13.3	15.9	18.5		
240			9.4	12.4	15.4	18.4	21.4	24.4	
270			10.5	13.8	17.2	20.5	23.9	27.2	
300			11.8	15.5	19.3	23.0	26.7	30.5	34.2

Customized sizes on request are available contact your Munters contact person.

# Technical specifications

Connection points and access space requirements for service

1. Supply air
2. Humidified air
3. Electrical connection point for pump
4. Cold-water connection female threaded coupling, 1/2" 18 mm
5. Discharge pipe with a rubber socket for piping with dimension d=50 mm / 2".
6. Access for inspection and servicing

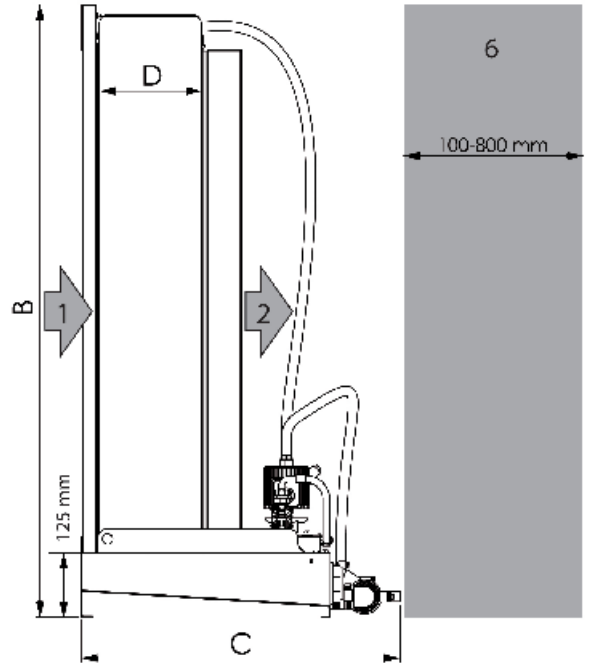
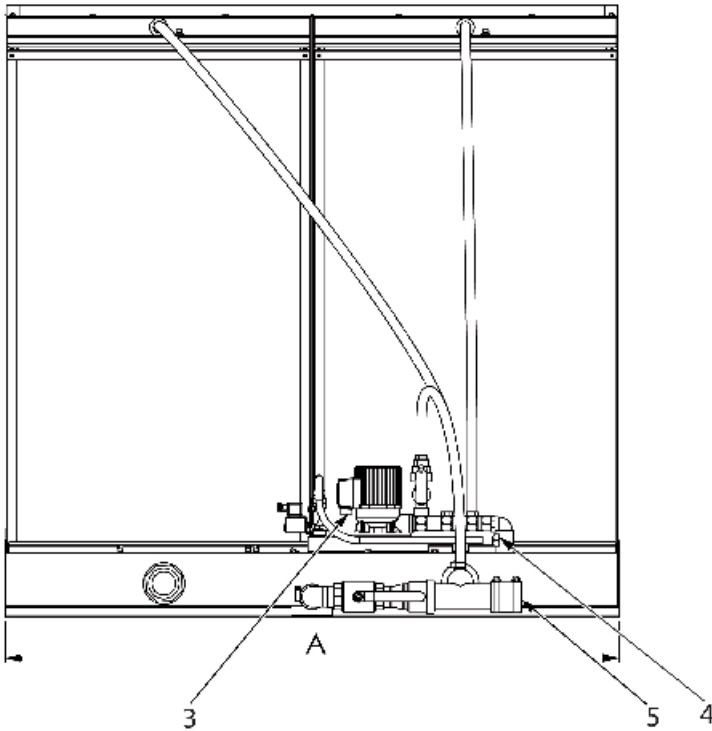

## Electrical data – circulation pump

Pump size (ref. p. 9)	Voltage V ±10%	Frequency Hz	Power W	Rated current A
8 KTF16	3-phase Δ230/Y400	50	49	0.26/0.15
9 KTF51	3-phase Δ230/Y400	50	75	0.38/0.22
10 KTF81	3-phase Δ230/Y400	50	140	0.71/0.41
11 KTF82	3-phase Δ230/Y400	50–60	220	0.95/0.55

## Sound attenuation\*

	Integral attenuation, dB							
	Octave band Hz							
	63	125	250	500	1,000	2,000	4,000	8,000
FA6-65	3	2	2	2	4	5	8	10
FA6-85	3	2	2	3	5	6	12	15
FA6-95	3	2	3	3	5	7	13	16

\*) Sound level for FA6 unit is not above 70 dB.

## Electrical – solenoid valve for step control

Voltage V ±10%	Frequency Hz	Power W
1-phase 230 V(AC)	50–60	43/24
24 V(AC)	50–60	15

## Maximum continuous operating temperature

	Air	Water
GLASdek	200 °C	40 °C
Mesh reinforced plastic hose	50 °C	50 °C
PVC pipes	50 °C	50 °C
Circulation pump ON	40 °C	80 °C
Circulation pump OFF	75 °C	80 °C

## Drain capacity

Bottom valve only	30 l/min
Overflow protection only	30 l/min
Bottom valve + overflow protection	60 l/min

Stated drain capacity is valid when using 50mm drain pipes.

## IP classes

Pump	54
Solenoid valve	65
Drain valve	54

# Design and operation

Two different types of systems are available *Circulating water* or *Direct water*.

## Circulating water FA6 units

A circulating water system is recommended to most applications/sizes to ensure low water consumption and low life cycle cost.

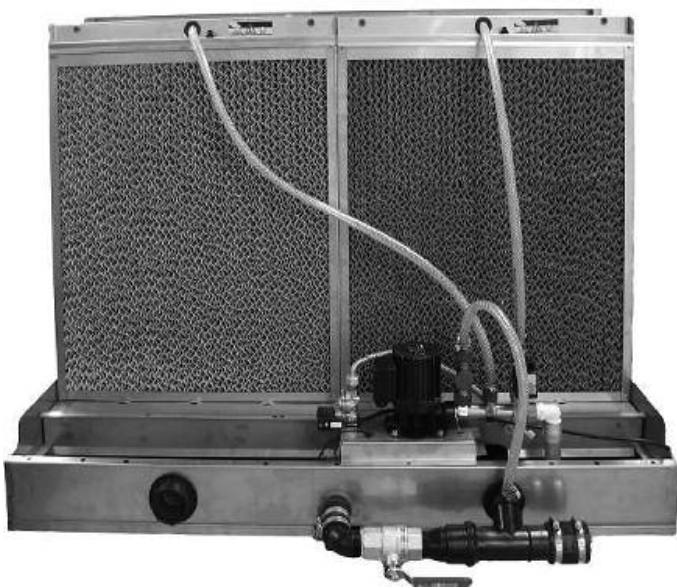

## Circulating-water models

The tray is filled with cold water from the mains and the water level is maintained by the level switch and solenoid valve. When there is a demand for humidification, the pump starts and delivers water to the water distribution assembly where it is supplied to the water distribution header. Each water distribution header assembly supplies sufficient water to the humidifier cassette. The water then flows down through the corrugated surface of the humidifier cassette. Some of the water is absorbed by the GLASdek<sup>®</sup> media and the rest runs down into the bottom tray. As the supply air passes through the media, a proportion of the water absorbed by the media evaporates on contact with the air to produce humidified air.

## Direct water FA6 units

Direct water systems are commonly used when the water quality is too poor for circulating systems or when the humidifiers' annual operation time is short. Direct water systems are not available in all sizes, see chart on page 17.

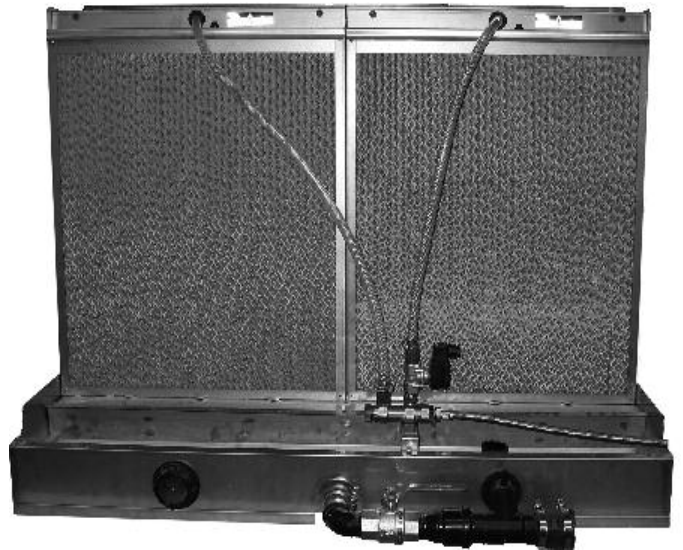

## Direct-water-supply models

The direct-water model does not have a water pump, therefore it is essential that the mains cold-water supply connected to the unit has adequate pressure and flow rate for the humidifier being installed. Mains cold water is supplied to the unit and is fed to the water distribution header via a constant flow valve. The constant flow valve ensures that the correct flow rate is supplied to the water distribution header of each cassette. The water flows downward through the corrugated surface of the humidifier cassette. Some of the water is absorbed by the GLASdek media and the rest runs down into the bottom tray. As the supply air passes through the humidifier, a proportion of the water absorbed by the media evaporates on contact with the air to produce humidified air. The water that reaches the bottom tray is discharged directly to the wastewater system through the discharge pipe.

# Design and operation

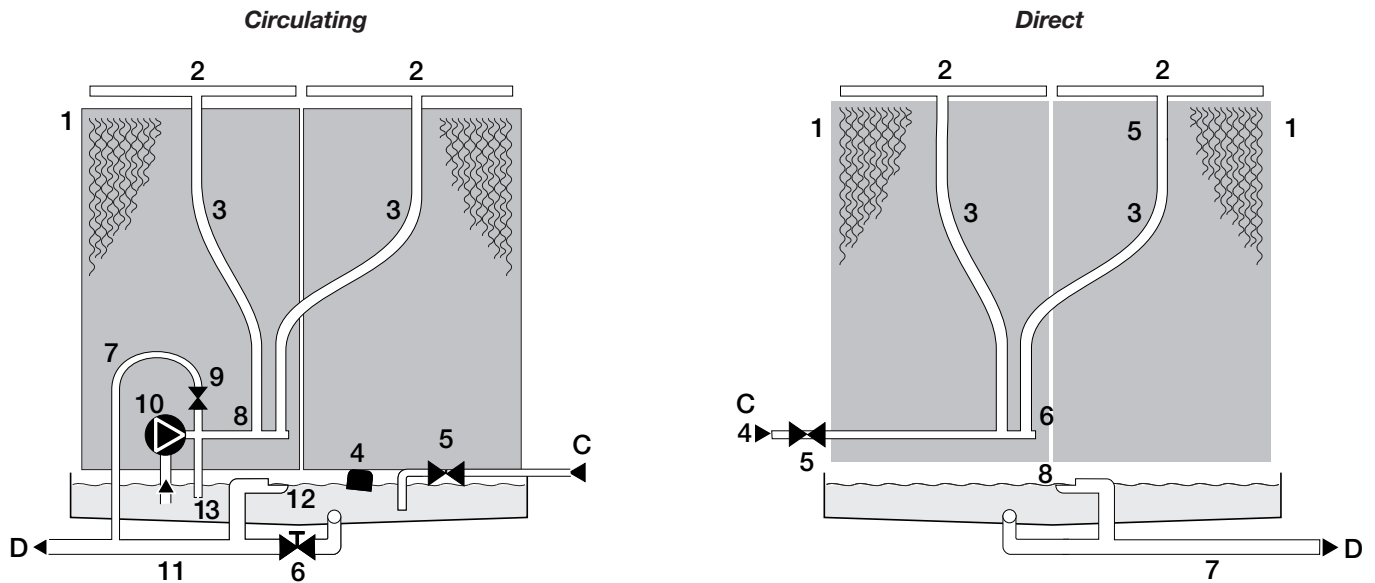

Function diagram

- |   |                                      |
|---|--------------------------------------|
| <b>C</b> Mains Cold-Water                   | <b>6</b> Reservoir Drain Valve       |
| <b>D</b> Discharge Water                    | <b>7</b> Bleed-off Drain             |
| <b>1</b> Humidifier Cassette                | <b>8</b> Water-Distribution Assembly |
| <b>2</b> Water-Distribution Header Assembly | <b>9</b> Bleed-off Control Valve     |
| <b>3</b> Water-Distribution Hose            | <b>10</b> Pump                       |
| <b>4</b> Level switch                       | <b>11</b> Discharge Pipe             |
| <b>5</b> Water inlet solenoid valve         | <b>12</b> Overflow Outlet            |
|   | <b>13</b> Pressure reduction         |

- |   |                                      |
|---|--------------------------------------|
| <b>C</b> Mains Cold-Water                   | <b>4</b> Mains Water Connection      |
| <b>D</b> Discharge Water                    | <b>5</b> Constant Flow Valve         |
| <b>1</b> Humidifier Cassette                | <b>6</b> Water Distribution Assembly |
| <b>2</b> Water-Distribution Header Assembly | <b>7</b> Discharge Pipe              |
| <b>3</b> Water-Distribution Hose            | <b>8</b> Overflow Outlet             |

## Bleed-off flow

Regular cold water from city mains contains a certain amount of minerals and salts, the concentration of which varies from place to place. During evaporation, pure water is released to the air. The minerals and salts remain in the water and are returned to the water reservoir. The concentration in the reservoir water therefore becomes higher than the supply water. If the mineral concentration (especially calcium) becomes too high, scale deposits may form on the surface of the media until they finally clog the humidifier. To combat the problem, a pro-

portion of the reservoir water must be drained and replaced with fresh water. The water that is drained off through the bleed-off valve via the bleed-off hose to the discharge pipe is called the bleed-off flow. The bleed-off flow rate is regulated using the bleed-off valve, so that the mineral concentration is kept at an acceptable level. Before the humidifier can be started up, the bleed-off flow rate must be calculated and set in accordance with the instructions on page 18 and in page 13 in FA6 installation/service manual.



# Control systems

There are four different Control systems available to control the humidity.

The FA6 can be easily controlled to address even the most demanding conditions.

The choice of control method depends mainly on the application and the desired accuracy of the system.

**On-Off** control system accuracy typical 5-10% relative humidity RH.

**Stage Control** controlling the individual cassettes, accuracy typical 3-5% RH.

**Face and By pass** the infinitely variable for very exact accuracy 1-2% RH.

**Dew point Control** measures the absolute humidity of the air from the humidifier and controls the pre-heater and re-heater to achieve the set value accuracy 1-2% RH.

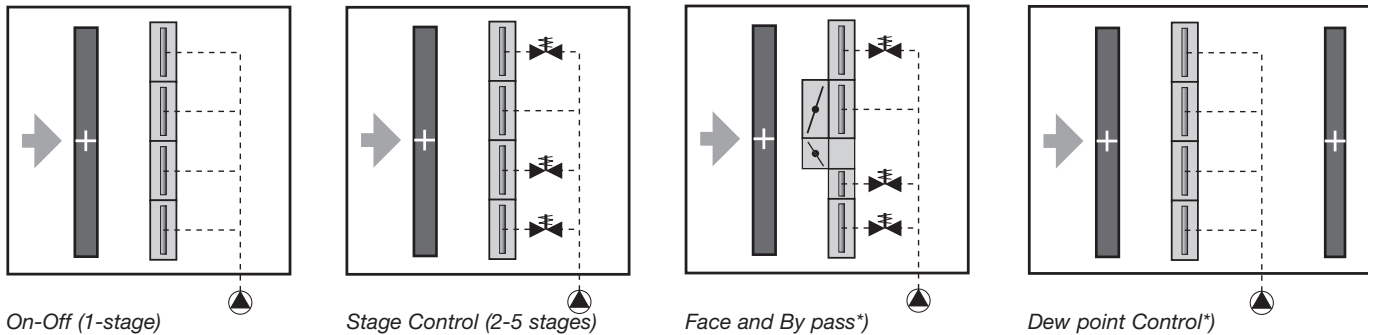

## On-off control

### Operation

The humidity sensor, GRh, measures the relative humidity in the room (or exhaust duct) and switches all the cassettes either on or off, to achieve a humidity level within the set lower and upper limit values.

The temperature sensor, GT, measures the temperature downstream of the supply-air fan and controls the preheater, to achieve the set value.

When humidity is required, the humidifier pump starts and all the cassettes are supplied with water. The RH level in the room rises relatively quickly to the set upper limit, since all the cassettes are in operation. The pump then stops and all the cassettes are taken out of operation. The RH level in the room then falls, reaching after some time the lower set value. The pump will then start again, stopping when the upper limit value has been reached.

The operating conditions of the system for varying ambient air humidity can be found in the ps chart.

### Control properties

An on-off control system provides an RH level in the room during the day that varies between the set maximum and minimum values independent of the humidity of the ambient air. The system starts and stops several times a day regardless of the actual humidity of the ambient air. The result in practice is a control accuracy of  $\pm 5-10$  percentage points RH.

### Operating time

Since the humidifier is greatly over-engineered for most of the year, the start and stop frequency will be high. The tighter the set tolerances (start and stop difference), the higher the start and stop frequency. In times of highly humid ambient air, the on interval for the humidifier is shorter than the off interval. When the humidity of ambient air is low, these conditions are reversed.

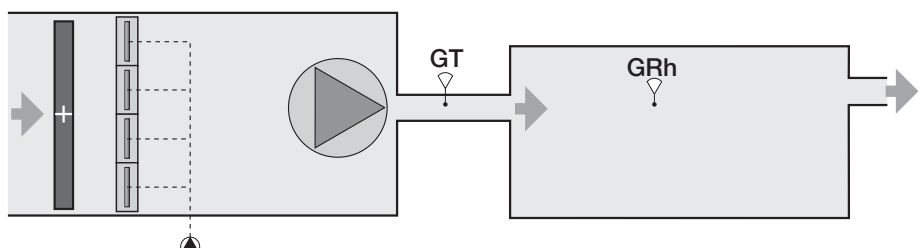

# Step control

## Operation

The humidity sensor, GRh, measures the relative humidity in the room (or exhaust duct) and opens the necessary solenoid valves, to achieve a humidity level within the set lower and upper limit values. The temperature sensor, GT (a mean-value type), measures the temperature downstream of the supply-air-fan and controls the preheater, to maintain the set value.

When humidity is required, the humidifier pump starts and the cassettes without solenoid valves are supplied with water. The dimensions of these cassettes are chosen so that the RH level in the room rises to just under the upper set limit value.

If the humidity of the ambient air drops, the RH level in the room falls. The relative-humidity sensor, GRh, opens the first solenoid valve when the level has reached the lower limit value. The size of the cassette for this solenoid has been chosen so that the RH level now rises again to just under the upper set limit value.

This sequence is repeated until all the solenoid valves are open. The operating conditions of the system for varying ambient air humidity can be found in the ps chart.

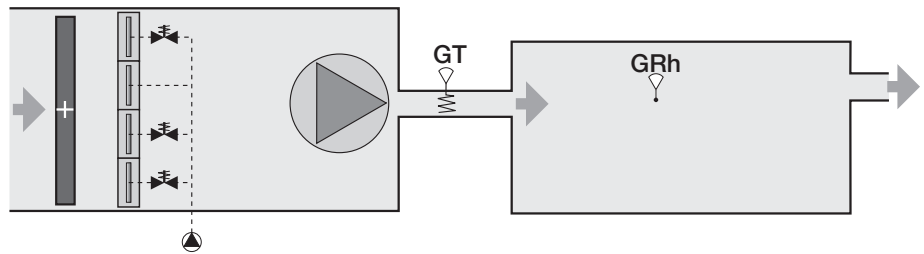

## Control properties

A system using step control provides RH level in the room during the day that varies between the set maximum and minimum values depending on the actual humidity of the ambient air. Four steps normally provide a control accuracy of  $\pm 3-5$  percentage points RH. The tighter the tolerances for set maximum and minimum values, the more steps are required.

## Operating time

A defined step relates to a certain humidity interval of the ambient air. During the spring, therefore, only one cassette is in operation. During the winter, four cassettes are in operation. Please see the diagram. This method of operation will minimize starts and stops. And this will increase the service life of the cassettes. Furthermore, the operating time for the cassettes is on average only half of what it is for the cassettes in a dew-point system.

# Face and by-pass control

## Operation

The humidity sensor, GRh, measures the relative humidity in the room (or exhaust duct) and opens the necessary number of solenoid valves as well as the face damper, or gradually closes the by-pass damper, to maintain the set value.

The temperature sensor, GT (a mean-value type), measures the temperature downstream of the supply-air fan and controls the preheater, to maintain the set value.

When humidity is required, the humidifier pump starts, supplying the cassette situated downstream of the face damper. When the face damper is fully open and there is a continued demand for humidification, one of the solenoid valves is opened and the face and by-pass dampers return to their original positions. Should additional humidity continue to be required, the face damper gradually opens and the by-pass damper closes to a corresponding degree. When the face damper has opened completely, the next solenoid opens and the face and by-pass dampers again return to their original positions.

This sequence is repeated until all the solenoid valves have opened. The operating conditions of the system for varying ambient air humidity can be found in the ps chart.

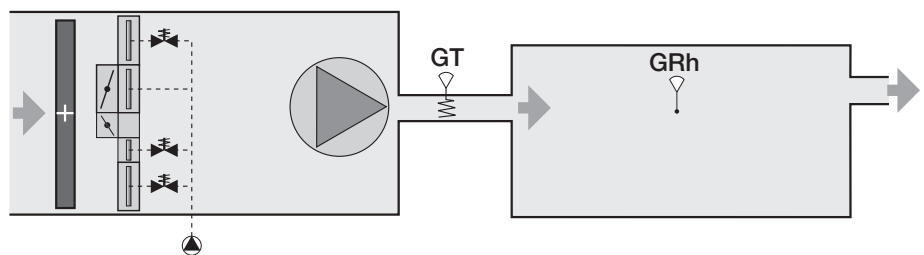

## Control properties

A Face and by-pass system provides an almost constant RH level in the room during the day regardless of the actual humidity of the ambient air. The result in practice is a control accuracy of  $\pm 1-2$  percentage points RH.

Note however that it is not possible to achieve the set humidity for the room, without pre-cooling, for conditions whereby the ambient air has a higher wet-bulb temperature than the room's wetbulb temperature.

## Operating time

This method of operation will minimize starts and stops and increase the service life of the cassettes. Furthermore, the operating time for the cassettes is on average only half of what it is for the cassettes in a dew-point system.

The system is highly cost effective compared with dew-point regulation, since there is no after-heater nor shunt unit.

# Dew point control

## Operation

The dew-point sensor GX, measures the absolute humidity of the air from the humidifier and controls the pre-heater to achieve the set value.

The temperature sensor, GT, measures the temperature of the supply air downstream of the inlet fan and controls the post heater to achieve the set value.

When humidity is required, the humidifier pump starts, and water is supplied to all the cassettes.

The operating characteristics of the system for varying ambient air humidity can be found in the ps. chart below.

## Control properties

A dew-point system provides an almost constant Rh level in the room during the day regardless of the actual humidity of the ambient air.

The result in practice is a control accuracy of  $\pm 1-2$  percentage points RH.

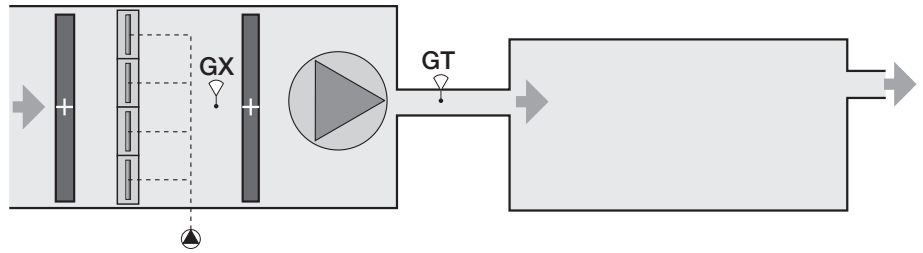

**Note** however that it is not possible to achieve the set humidity for the room, without pre-cooling, for conditions when the ambient air is above an imaginary line between the room dew point and the condition before the humidifier at design ambient air humidity.

## Operating time

Operation of the unit utilizes all of the humidifier cassettes as soon as a need for humidity exists.

**Note** A constant interval heat load is assumed for a constant room temperature. If this is not the case, a room-temperature sensor should be added.

# Options

The customer-order models and accessories below have been described only briefly.

Please contact your local Munters office for additional information.

## Height

The FA6 is available in special heights in case it is necessary to utilize the maximum height of the air-conditioning unit.

## High temperature

Direct water models can be adapted for high temperature applications (100 °C). Normally used in recirculation paint-booths where high temperatures occur during the drying cycle.

## Special cassette sets

Each standard size FA6 has a specific number of 300 mm or 600 mm wide cassettes. For applications requiring close control, two 300 mm cassettes may be used to replace a single 600 mm cassette. Additional solenoid valve must then be installed for each cassette.

## Pump motor and special electrical data

The standard pump has a motor designed for 3-phase, 400V/50 Hz operation or 3-phase 230V/50 Hz. Motors for 3-phase operation using other voltages and/or frequencies are available, as are motors for 1-phase, 230V/50 Hz and 120V/60 Hz operation.

## Constant-flow valves

Specially designed constant-flow valves for systems using direct-water are available. If a humidifier is to be used for indi-

rect evaporative cooling utilizing direct water, the constant-flow valves can be designed for half the nominal flow.

## Droplet separators

Used to eliminate the risk of carry-over due to high air velocities or turbulent airflow. They are very easy to install and do not change the FA6 humidifier's space requirement. Droplet separators are recommended for all installations with a face velocity over 3.5 m/s.

## Total Emptying of water distribution according to VDI 6022 German requirements.

Direct water units can be ordered with a special designed distribution pipe. The distribution pipe is equipped with motorized drain valve for automatic drainage.

For total emptying of distribution pipes after shutdown.

## External pump station

For extra high service availability Munters can supply an external pump station.

Contact your Munters Contact person for details

## Control system for step control

Control system for max 6 steps can be supplied. Number of steps depending on Humidifier size.

## Control system for face and Bypass

Control system for max 6 steps and two outputs for damper actuator can be supplied.

Number of steps depending on Humidifier size.

# BMS integration and improved hygiene

In most cases water treatments are not necessary, but in cases with poor water quality, it can be necessary to add a water treatment.

## FA6cc, Clean Concept

A bolt on enhancement for the FA6 humidifier that enables circulating water models to operate at optimum hygiene levels. The system incorporates a control panel with BMS connections, electronic level control and automatic drainage of the reservoir. The system has options for biocide dosing and conductivity controlled bleed-off. FA6cc is designed to exceed current legislation in relation to the control of bacteria in water systems in many countries – e.g. ACOP L8 in the U.K For more information, please refer to the FA6cc technical manual.

## FA6 Dosing system

The FA6ds, Dosing System is further enhancement of the FA6cc that enables time controlled, and/or externally controlled, dosing of biocides into the humidifier tray. The system is supplied with all the necessary parts required for connecting to the FA6 Evaporative Humidifier/Cooler, excluding the biocide with container.

## FA6 UV sterilization system

A recirculating water UV sterilization system kills harmful bacteria and viruses in water using UV light.

## FA6cs, Conductivity System

Enables conductivity controlled bleed-off. The system reduces water consumption and is especially effective with stage-controlled humidifier/coolers.

# Dimensioning

## How to select your FA6?

Selection of the right FA6 unit is easy with the advanced FA6 Dimensioning Program.

The program is based on weather data collected over many years for almost all locations globally. All you need to know are the following parameters:

- Air volume
- Duct dimensions or the cross-section of the AHU
- Design conditions (location)
- Required control accuracy
- Type of application (Humidification/Cooling)
- Required air conditions

## FA6 Dimensioning program

A Windows based program is available to help quickly select the right-sized FA6. The program provides correct humidity data and other relevant information required for the installation in question. The program can serve as a valuable supplement to this catalogue. Please contact your nearest sales office for additional information.

Result at design condition.	
Intake air	Preheat
Tdb °C: -12.1	46.0
Hum %: 50.0	7.1
Supply air	
Tdb °C: 22.0	
Hum %: 55.0	

Application	Humidification
Control mode	Step control
Selected unit	FA6-05-100-100-03-0-1
Unit weight wet/dry kg	210 / 98
Face velocity m/s	0.1
Pressure drop Pa	69
Efficiency %	95.3
Design utilization %	87.1
Design evaporation liters	4.77
Max supply water l/min	
Bleed off flow l/min	
Design parameters kW	546
Design parameters kW	
Design cooling °C	
Annual calculation	JA
Water quality test	NEJ

# Selection of humidifier size

Humidifier airflow range 0.5-4 m<sup>3</sup>/s

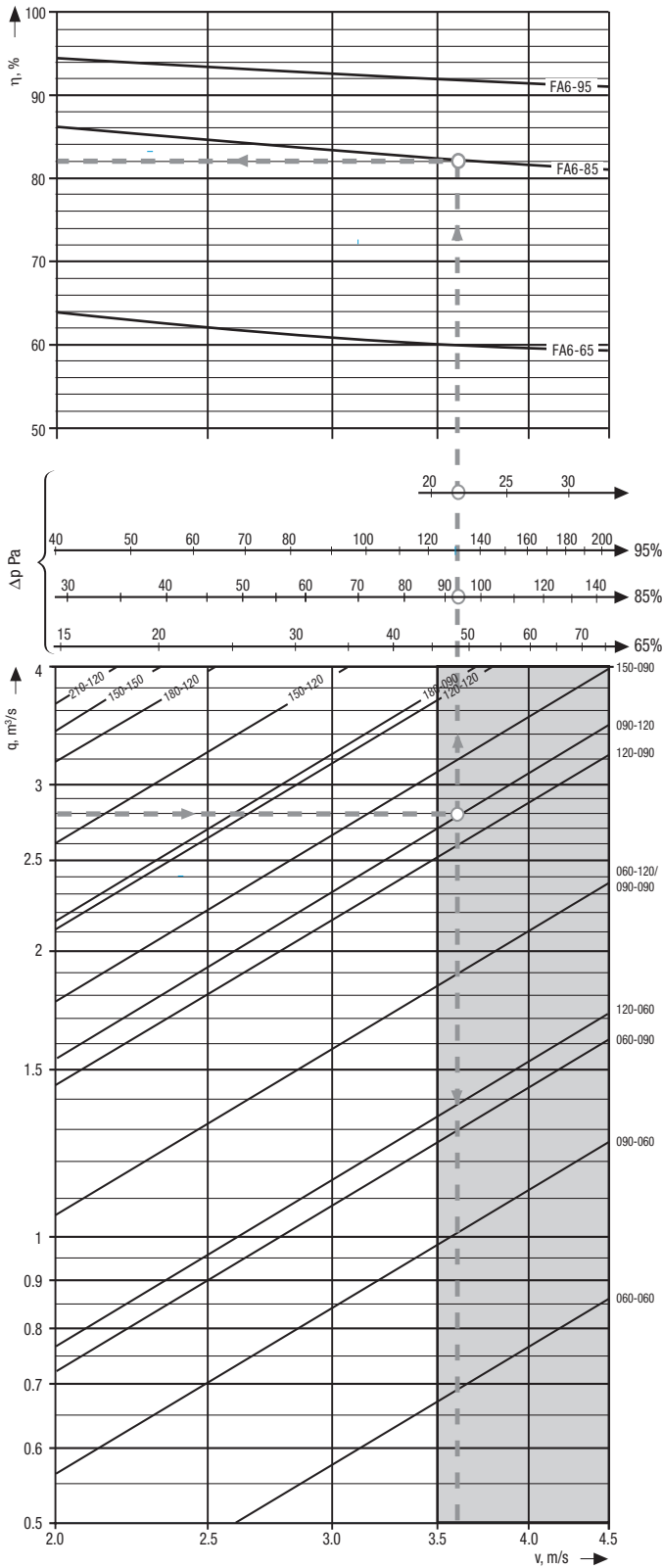

**Example** The diagram shows if the selected humidifier is the FA6-85-090-120 equipped with a droplet separator: Airflow,  $q = 2.8$  m<sup>3</sup>/s. Air velocity,  $v=3.6$  m/s. Pressure drop humidifier,  $\Delta p_{85\%} = 92$  Pa. Pressure drop droplet separator,  $\Delta p = 22$  Pa. Humidification efficiency,  $\eta=82\%$

# Calculating humidified air properties: Example

Humidification efficiency  $\eta=82\%$ .  
Supply air (winter) :  $t_0=-5$  °C and  $x_0= 2.0$  g/kg.

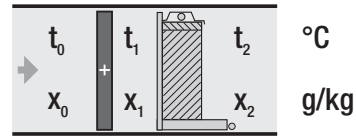

The outside supply air is pre-heated to:  $t_1=35$  °C and  $x_1 = 2.0$  g/kg, giving a wet-bulb temperature of  $t_w=14.6$  °C, and a saturated air content of  $x_w=10.4$  g/kg (see psychrometric chart below).

The condition of the humidified air downstream of the humidifier can be calculated as:  
 $x_2 = x_1 + \eta/100x (x_w - x_1) = 2.0 + 82/100x (10.4 - 2.0) = 8.9$  g/kg  
 $t_2 = t_1 + \eta/100x (t_w - t_1) = 35 + 82/100x (14.6 - 35) = 18.3$  °C

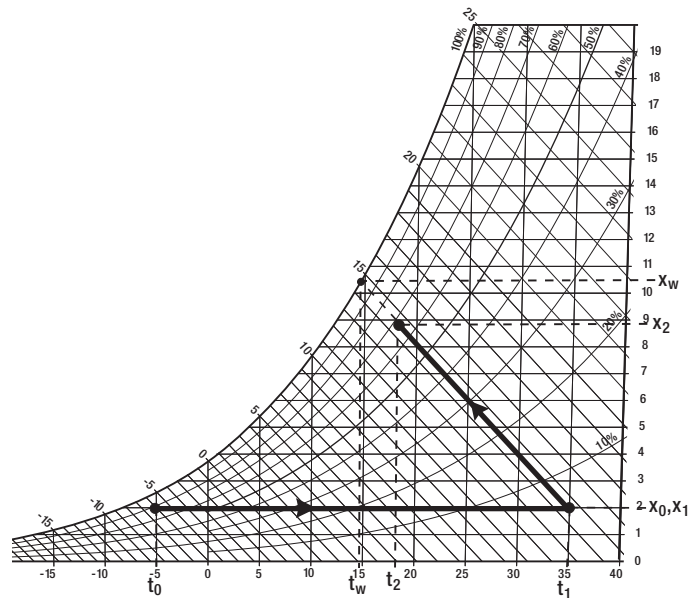

Definition of humidification efficiency,  $\eta$  %  
 $\eta = (x_2 - x_1) / (x_w - x_1) \times 100$

# Charts for selection of Humidifier sizes

Humidifier airflow range 4-10 m/s

Humidifier airflow range 10-30 m/s

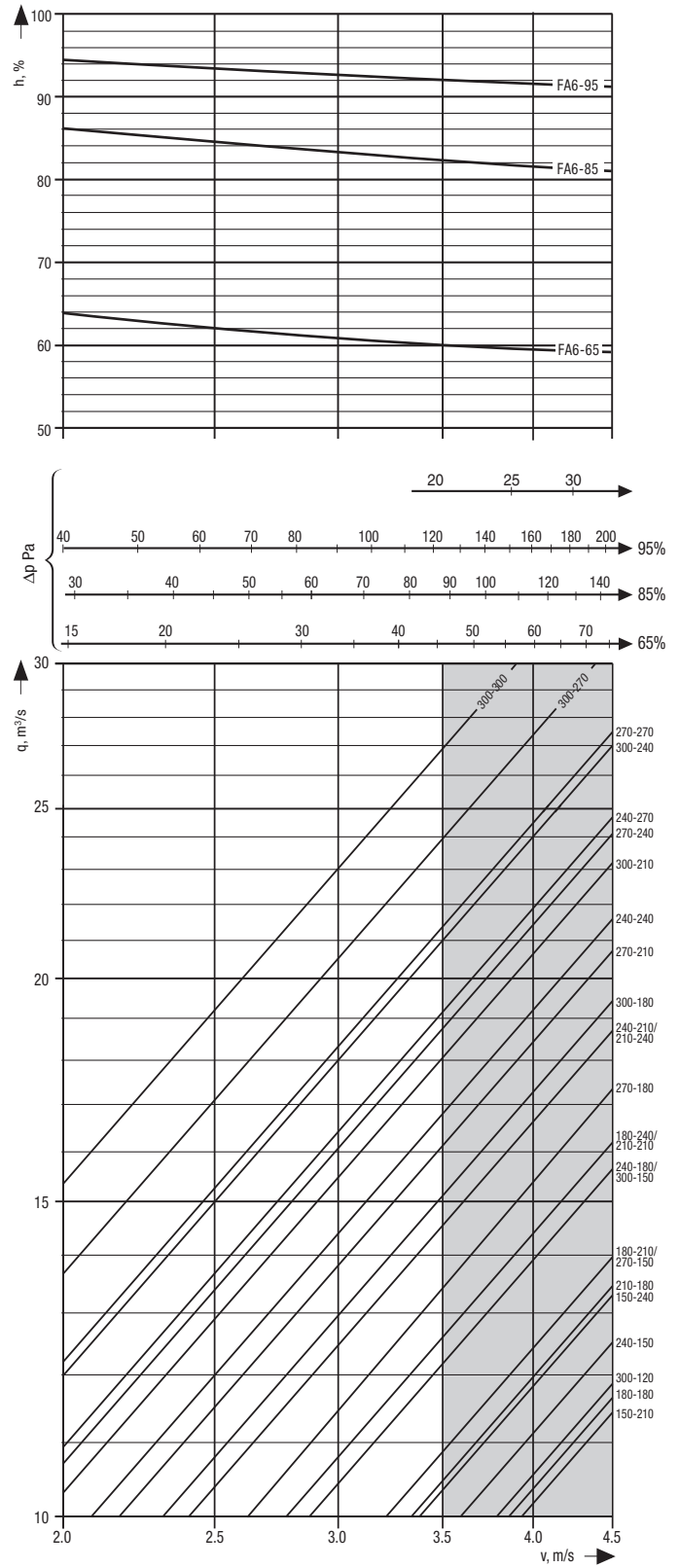
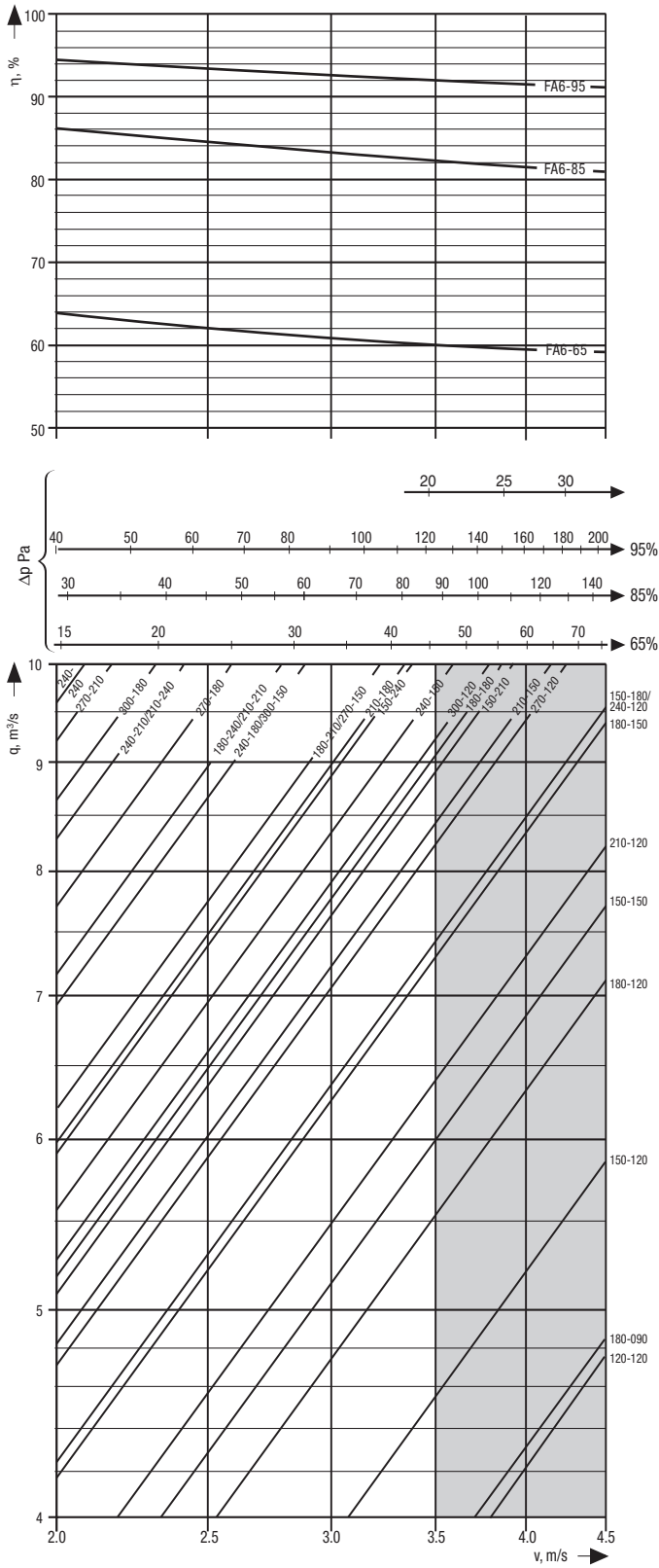

Droplet separator recommended for air velocities above 3.5 m/s.

## Dimensions, weights and pump sizes

Size	Dimensions mm				FA6-65			FA6-85			FA6-95		
					C=630 mm, D=100 mm			C=630 mm, D=200 mm			C=730 mm, D=300 mm		
	Qry cassettes		Pump size	Weight kg		Pump size	Weight kg		Pump size	Weight kg			
	Width	Width		Wet	Dry		Wet	Dry		Wet	Dry		
A	B	300mm	600mm										
060-060	600	600	1	1	8	44	23	8	50	26	8	58	28
060-090		900			8	49	26	8	57	30	8	70	33
060-120		1200			8	52	28	8	64	33	9	80	38
090-060	900	600	1	1	8	60	29	8	69	33	8	84	39
090-090		900			8	66	32	8	78	38	8	100	46
090-120		1200			8	73	35	8	91	43	9	116	53
120-060	1200	600	2	2	8	76	35	8	88	41	9	106	48
120-090		900			8	84	39	8	100	46	9	129	56
120-120		1200			8	92	42	8	115	52	9	148	64
150-090	1500	900	1	2	8	103	48	8	124	56	9	159	67
150-120		1200			8	113	51	8	142	62	9	184	79
150-150		1500			8	123	55	9	159	71	9	208	90
150-180		1800			8	134	60	9	178	79	9	237	102
150-210		2100			8	141	64	9	197	88	9	262	113
150-240		2400			8	150	68	9	212	95	10	286	123
180-090	1800	900	3	3	8	118	50	8	142	61	9	185	76
180-120		1200			8	134	59	8	169	74	9	218	91
180-150		1500			8	146	64	9	187	82	9	247	104
180-180		1800			8	158	70	9	210	92	10	281	118
180-210		2100			8	165	74	9	233	102	10	309	130
180-240		2400			8	177	79	9	250	109	10	338	142
210-120	2100	1200	1	3	8	156	68	9	197	86	10	254	107
210-150		1500			8	169	74	9	219	96	10	288	121
210-180		1800			8	184	81	9	245	108	10	328	138
210-210		2100			8	193	85	9	271	118	10	362	153
210-240		2400			8	206	91	9	292	128	11	395	167
240-120	2400	1200	4	4	8	175	75	9	221	95	10	286	118
240-150		1500			8	191	82	9	246	106	10	325	134
240-180		1800			8	206	89	9	276	119	11	370	153
240-210		2100			8	216	94	9	306	131	11	407	169
240-240		2400			8	232	101	9	329	141	11	446	185
240-270		2700			9	247	107	9	359	153	11	483	195
270-120	2700	1200	1	4	8	197	84	9	250	107	10	323	133
270-150		1500			8	241	91	9	278	119	10	366	152
270-180		1800			8	232	100	9	310	134	11	417	173
270-210		2100			8	244	106	9	345	148	11	461	192
270-240		2400			9	261	113	10	372	160	11	503	210
270-270		2700			9	277	120	10	405	174	11	554	231
300-120	3000	1200	5	5	8	216	91	9	274	116	11	355	145
300-150		1500			8	235	99	9	304	129	11	403	164
300-180		1800			8	254	108	10	341	145	11	459	186
300-210		2100			8	267	114	10	380	161	11	505	207
300-240		2400			9	286	122	10	408	173	11	554	227
300-270		2700			9	305	130	10	445	188	11	610	250
300-300		3000			9	336	141	10	462	222	11	638	309

*Humidifier with height over 210 cm are delivered disassembled.*

*Upon request other sizes can be delivered disassembled.*

# Water Quality /Data

Following page is based on FA6 with Clean concept control

**Total alkalinity as mg/l HCO<sub>3</sub><sup>-</sup>**

	10	20	30	40	50	60	70	80	90	100	125	150	175	200	250	300	350	400	450	500	
Total hardness as mg/l Ca <sup>2+</sup>	10	6.0	6.0	6.0	6.0	6.0	6.0	6.0	6.0	6.0	6.0	6.0	5.5	5.0	4.4	3.9	3.5	3.2	3.0	2.8	
	20	6.0	6.0	6.0	6.0	6.0	6.0	6.0	6.0	6.0	6.0	5.3	4.7	4.2	3.9	3.3	3.0	2.7	2.5	2.3	2.1
	30	6.0	6.0	6.0	6.0	6.0	6.0	6.0	6.0	5.6	5.2	4.5	4.0	3.6	3.3	2.9	2.5	2.3	2.1	1.9	1.8
	40	6.0	6.0	6.0	6.0	6.0	6.0	5.9	5.4	5.0	4.7	4.1	3.6	3.3	3.0	2.6	2.3	2.1	1.9	1.7	1.6
	50	6.0	6.0	6.0	6.0	6.0	6.0	5.5	5.0	4.6	4.3	3.7	3.3	3.0	2.7	2.4	2.1	1.9	1.7	1.6	1.5
	60	6.0	6.0	6.0	6.0	6.0	5.6	5.1	4.7	4.3	4.0	3.5	3.1	2.8	2.6	2.2	2.0	1.8	1.6	1.5	1.4
	70	6.0	6.0	6.0	6.0	6.0	5.3	4.8	4.4	4.1	3.8	3.3	2.9	2.6	2.4	2.1	1.8	1.7	1.5	1.4	1.3
	80	6.0	6.0	6.0	6.0	5.7	5.1	4.6	4.2	3.9	3.6	3.1	2.8	2.5	2.3	2.0	1.8	1.6	1.5	1.3	1.3
	90	6.0	6.0	6.0	6.0	5.5	4.8	4.4	4.0	3.7	3.5	3.0	2.6	2.4	2.2	1.9	1.7	1.5	1.4	1.3	1.2
	100	6.0	6.0	6.0	6.0	5.2	4.6	4.2	3.8	3.6	3.3	2.9	2.5	2.3	2.1	1.8	1.6	1.5	1.3	1.2	1.2
	125	6.0	6.0	6.0	5.6	4.8	4.3	3.9	3.5	3.3	3.0	2.6	2.3	2.1	1.9	1.7	1.5	1.3	1.2	1.1	1.1
	150	6.0	6.0	6.0	5.2	4.5	4.0	3.6	3.3	3.0	2.8	2.5	2.2	2.0	1.8	1.6	1.4	1.2	1.1	1.1	1.0
	175	6.0	6.0	5.9	4.9	4.2	3.8	3.4	3.1	2.9	2.7	2.3	2.1	1.9	1.7	1.5	1.3	1.2	1.1	1.0	0.9
	200	6.0	6.0	5.6	4.7	4.0	3.6	3.2	3.0	2.7	2.6	2.2	2.0	1.8	1.6	1.4	1.2	1.1	1.0	0.9	0.9
	250	6.0	6.0	5.2	4.3	3.7	3.3	3.0	2.7	2.5	2.3	2.0	1.8	1.6	1.5	1.3	1.1	1.0	0.9	0.9	0.8
	300	6.0	6.0	4.8	4.0	3.5	3.1	2.8	2.5	2.3	2.2	1.9	1.7	1.5	1.4	1.2	1.1	1.0	0.9	0.8	0.8
	350	6.0	5.9	4.6	3.8	3.3	2.9	2.6	2.4	2.2	2.1	1.8	1.6	1.4	1.3	1.1	1.0	0.9	0.8	0.8	0.7
	400	6.0	5.7	4.3	3.6	3.1	2.7	2.5	2.3	2.1	2.0	1.7	1.5	1.4	1.2	1.1	1.0	0.9	0.8	0.7	0.7
	450	6.0	5.4	4.1	3.4	3.0	2.6	2.4	2.2	2.0	1.9	1.6	1.4	1.3	1.2	1.0	0.9	0.8	0.8	0.7	0.7
	500	6.0	5.2	4.0	3.3	2.8	2.5	2.3	2.1	1.9	1.8	1.6	1.4	1.2	1.1	1.0	0.9	0.8	0.7	0.7	0.6

Cycles <2: Conductivity controlled bleed-off not recommended

Cycles <1.5: Direct water recommended

Cycles <1: Non-usable water

The table shows the maximum recommended cycles of concentration for different water qualities. Cycles of concentration = mineral concentration in humidifier water/mineral concentration in supply water. The cycle value is used to calculate the bleed off. If the cycle rate is 2 or lower, it is recommended that a direct water system be used instead of circulating water, or the supply water should be treated to improve the water quality. The conversion table below can be used to convert local measuring units to fit the table.

Total hardness (calcium hardness)	
°dH	°dH × 7.2 ⇒ mg/l Ca <sup>2+</sup>
°f	°f × 4.0 ⇒ mg/l Ca <sup>2+</sup>
°clark	°clark × 5.7 ⇒ mg/l Ca <sup>2+</sup>
ppm CaCO <sub>3</sub>	ppm CaCO <sub>3</sub> × 0.25 ⇒ mg/l Ca <sup>2+</sup>
Total alkalinity (carbonate hardness, bicarbonate)	
°dH	°dH × 21.8 ⇒ mg/l HCO <sub>3</sub> <sup>-</sup>
ppm CaCO <sub>3</sub>	ppm CaCO <sub>3</sub> × 1.2 ⇒ mg/l HCO <sub>3</sub> <sup>-</sup>
ppm NaOH	ppm NaOH × 1.5 ⇒ mg/l HCO <sub>3</sub> <sup>-</sup>
General	
Concentration	mg/l = g/m <sup>3</sup> = ppm
Conductivity	1mS/m = 10 µS/cm = 10 µMHO

The total water consumption (T) is the sum of the evaporated water quantity (E) and the bleed-off quantity (B). When estimating the evaporated water quantity, use the average running conditions for the installation.

## Example

Airflow	q = 2.8 m <sup>3</sup> /s
Average moisture content of supply air	x <sub>1</sub> = 2.0 g/kg
Average moisture content of humidified air	x <sub>2</sub> = 9.0 g/kg

Total hardness 80 mg/l Ca<sup>2+</sup>  
Total alkalinity 100 mg/l HCO<sub>3</sub><sup>-</sup>

- Cycles of concentration from table:  
C = 3.6
- Calculate the average evaporation:  
E = q × 60 × 1.2 × (x<sub>2</sub> - x<sub>1</sub>) / 1,000 = 2.8 × 60 × 1.2 × (9-2) / 1,000 = 1.41 l/min
- Calculate the bleed-off:  
B = E / (C-1) = 1.41 / (3.6-1) = 0.54 l/min
- The total water consumption can be calculated:  
T = E + B = 1.41 + 0.54 = 1.95 l/min

## Water from other sources

If the supply water is not classified as drinking water from the mains the following additional concentration limits are recommended.

Chlorides (mg/l Cl <sup>-</sup> )	Cl <sup>-</sup> × C < 200 mg/l
Sulphates ( mg/l SO <sub>4</sub> <sup>2-</sup> )	SO <sub>4</sub> <sup>2-</sup> × C < 300 mg/l
Bacteria rate (CFU/ml, KBE/ml)	CFU/ml × C < 1000

Multiply the concentration by the cycle ratio (C) and compare to the recommended limit. If the value is over the limit, reduce the cycle rate.

When using softened water, the total hardness can't be used for dimensioning the bleed-off. Instead use a conductivity limit of 1,000 µS/cm to calculate the cycle ratio. Supply conductivity × C < 1,000 µS/cm.

In poor water quality areas, a blend of treated water and raw water can be used to lower the mineral content. The water should be blended so that the conductivity >100 µS/cm. If the blended water is too clean it may leech the minerals out of the GLASdek<sup>®</sup>, cassettes and thereby seriously damage them.



## Total water consumption (T) for direct-supply-water model

Models	FA6-65	FA6-85	FA6-95
	T l/min	T l/min	T l/min
060-060	1.8	3.5	3.5
060-090	1.8	3.5	3.5
060-120	1.8	3.5	3.5
090-060	2.8	6.3	6.3
090-090	2.8	6.3	6.3
090-120	2.8	6.3	6.3
120-060	3.5	8.0	8.0
120-090	3.5	8.0	8.0
120-120	3.5	8.0	8.0
150-090	4.5	10.0	10.0
150-120	4.5	10.0	10.0
150-150	4.5	10.0	10.0
150-180	6.3	10.0	12.0
150-210	8.0	12.0	15.0
150-240	8.0	15.0	18.0
180-090	6.3	12.0	12.0
180-120	6.3	12.0	12.0
180-150	6.3	12.0	12.0
180-180	8.0	12.0	15.0
180-210	8.0	15.0	18.0
180-240	10.0	15.0	
210-120	6.3	15.0	15.0
210-150	6.3	15.0	15.0
210-180	8.0	15.0	18.0
210-210	10.0	15.0	
210-240	12.0	18.0	
240-120	8.0	15.0	15.0
240-150	8.0	15.0	15.0
240-180	10.0	15.0	
240-210	12.0	18.0	
240-240	12.0		
240-270	15.0		
270-120	10.0	18.0	18.0
270-150	10.0	18.0	18.0
270-180	10.0	18.0	
270-210	12.0		
270-240	15.0		
270-270	15.0		
300-120	10.0	18.0	18.0
300-150	10.0	18.0	
300-180	12.0	18.0	
300-210	15.0		
300-240	18.0		
300-270	18.0		
300-300			

 Special design with increased draining capacity is required.

## Pressure requirements at water supply connection point

	Pressure requirements	
	Circulating water	Direct water
Required min. pressure at connection point	500 kPa* (5.0 bar)	150 kPa (1.5 bar)
Permitted max. pressure at connection point	1,000 kPa (10.0 bar)	1,000 kPa (10.0 bar)

## Circulating water model

The total water consumption is the sum of evaporated water and the bleed-off. The bleed-off is a constant discharge flow that is necessary to maintain the mineral concentration in the tray at such a level that the service life of the humidifier cassettes may be optimised. The recommended amount of bleed-off depends on the quality of the supply water. If the water quality is not known a water analysis may be carried out, but it is often simpler to ask the local water company for analysis data. Based on tests performed and operating evaluations of various systems, Munters has established the following recommendations see page 18.

# Water consumption

## Direct water

The total water consumption is a sum of the total number of running hours. The table in page 17 specifies the maximum water consumption (l/min) when water supply is on.

## Circulating water model

The total water consumption is the sum of the evaporated water (E) and the bleed-off amount (B). The bleed-off is the constant discharge flow that is necessary to maintain the mineral concentration in the circulating water at such a level that the service life of the FA6 humidification cooling pad is optimised.

## Bleed-off factor

The bleed-off factor (B) is obtained from the quality diagram below if the water quality is known. A water analysis may be carried out, but it is often simpler to ask the local water company for analysis data.

If the bleed-off factor is above 2, it is recommended that a

direct water system is used instead of circulating water, or the water supply should be treated to improve the water quality.

## Example

Airflow	$q = 2.8 \text{ m}^3/\text{s}$
Average moisture content of supply air	$x_1 = 2.0 \text{ g/kg}$
Average moisture content of humidified air	$x_2 = 9.0 \text{ g/kg}$
Total hardness	100 mg/l $\text{Ca}^{2+}$
Total alkalinity	100 mg/l $\text{HCO}_3^-$

- Bleed-off factor from table:  $f_B = 0.3$
- Calculate the average evaporation:  
 $E = q \times 60 \times 1.2 \times (x_2 - x_1) / 1,000 = 2.8 \times 60 \times 1.2 \times (9 - 2) / 1,000 = 1.41 \text{ l/min}$
- Calculate the bleed-off:  $B = f_B \times E = 0.3 \times 1.41 = 0.42 \text{ l/min}$
- The total water consumption can be calculated:  
 $T = E + B = 1.41 + 0.42 = 1.83 \text{ l/min}$

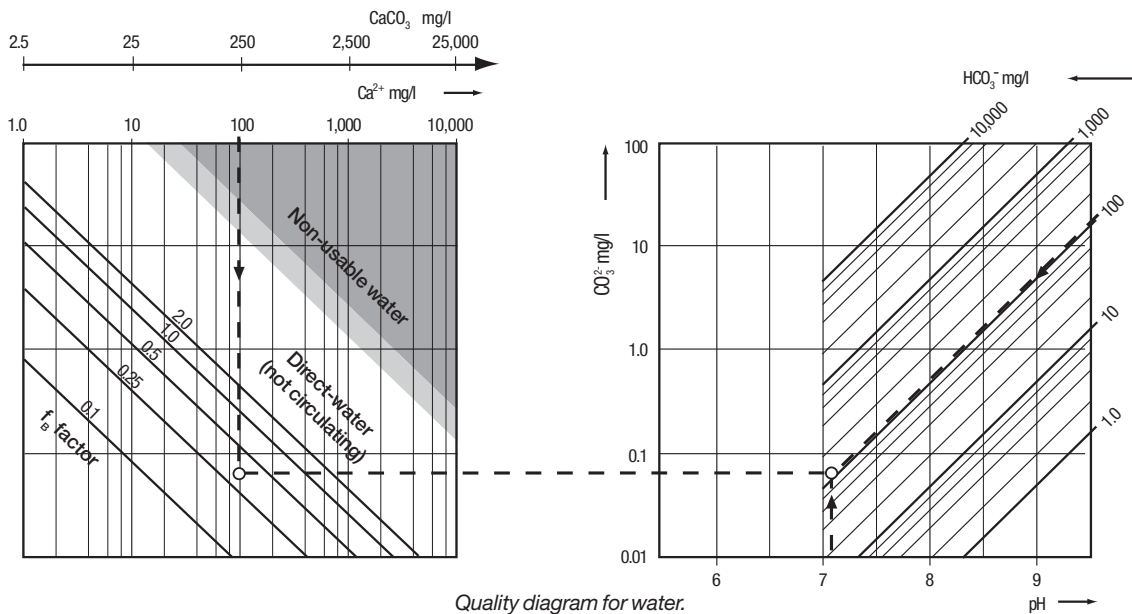

# Water quality

## Water from other sources

If the supply water is not classified as drinking water from the mains the following additional concentration limits are recommended.

Chlorides (mg/l $\text{Cl}^-$ )	$\text{Cl}^- \times C < 200 \text{ mg/l}$
Sulphates (mg/l $\text{SO}_4^{2-}$ )	$\text{SO}_4^{2-} \times C < 300 \text{ mg/l}$
Bacteria rate (CFU/ml, KBE/ml)	$\text{CFU/ml} \times C < 1000$

Multiply the concentration by the cycle ratio (C) and compare to the recommended limit. If the value is over the limit, reduce the cycle rate.

When using softened water, the total hardness can't be used for dimensioning the bleed-off. Instead use a conductivity limit of 1000  $\mu\text{S/cm}$  to calculate the cycle ratio. Supply conductivity  $\times C < 1000 \mu\text{S/cm}$ .

## General water hardness conversion table $\text{CaCO}_3$

Water condition	Hardness [dH]	$\text{CaCO}_3$ [mg/l]
Very soft	0–2	0–36
Soft	2–5	36–90
Normal	5–10	90–179
Hard	10–21	179–376
Very hard	>21	>376

In poor water quality areas, a blend of treated water and raw water can be used to lower the mineral content. The water should be blended so that the conductivity  $> 100 \mu\text{S/cm}$ . If the blended water is too clean it may leech the minerals out of the GLASdek<sup>®</sup>, cassettes and thereby seriously damage them.

# Ordering key

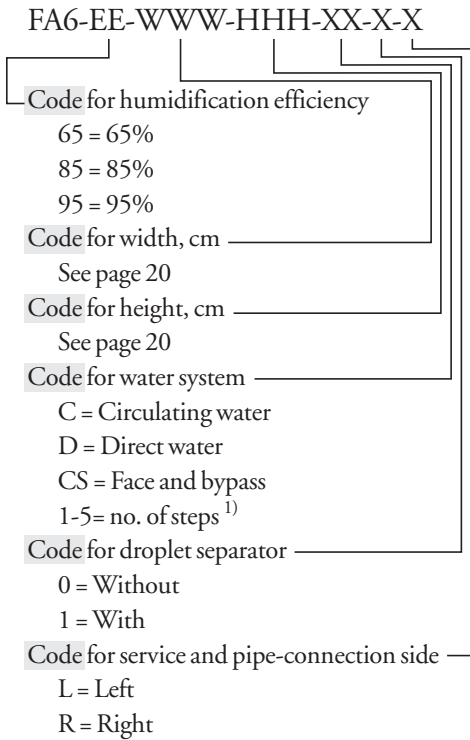

e.g., FA6-85-120-090-C1-0-L

## Comments

Humidifiers with height over 210 cm are delivered disassembled.

Upon request other size can be delivered disassembled.

The standard delivery does not include, water filter or water trap these parts can be ordered as accessories.

<sup>1)</sup>When the number of steps = 1, no solenoid valve is included for step control.

In the case of more steps than one, the number of solenoid valves depends on the number of cassettes in the humidifier. Your contact person at Munters will be able to furnish you with full details.

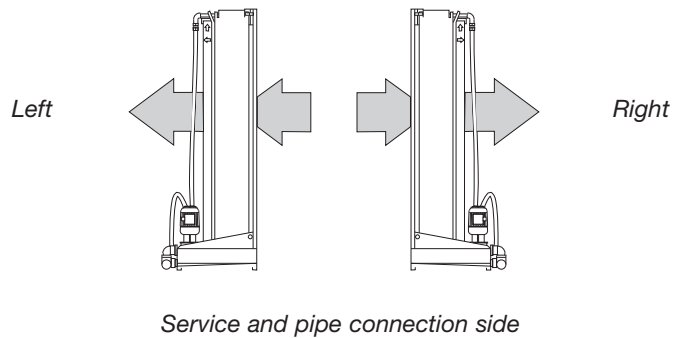

# Design standards, approvals and certifications

FA6 humidifier/Cooler is manufactured in accordance with the following Harmonized European standards and technical specifications.

- EN 60204-1 edition 3 Safety of machinery, electrical equipment of machines.
- EN 61000-6-3 edition 1 Electromagnetic compability EMC Emissions standard for Residential, commercial and light-industrial environments.
- EN 61000-6-3/A11 Electromagnetic compability EMC Emissions standard for Residential, commercial and light-industrial environments.
- EN 61000-6-1 Electromagnetic compability EMC Emissions standard for Residential, commercial and light-industrial environments.

It agrees, with the limitations that have been stipulated for machines, with the most important health and safety requirements of Machinery Directive 2006/42/EG and furthermore 2004/108/EC with guideline for Electromagnetic compability.

## Humidifier cassette

The glass-fiber material GLASdek<sup>®</sup> used for the humidifier cassette has been fire tested and classified as non-combustible material according to the test standard ISO 1182. The glass-fiber

material GLASdek<sup>®</sup> used for the droplet separator cassette has been fire tested and classified as nonflammable material class 1, according to BS 476: part 7, M1 according to the French CSTB, and class T1 according to JISA 1322, Japan. This corresponds to NordTestFire 004, class 1, and the German DIN 4102, part 1, class B1 in accordance with Svensk Standard (Swedish Standard) SS28418.

## Selection of materials

The major standard components of the Munters FA6 humidifier and their materials of construction are listed below.

- The frame, cassette profiles, pump bracket, pump filter, water distribution headers and bottom trough are manufactured from stainless steel, EN 1.4301.
- The humidifier cassettes and droplet separator are of nonflammable glass-fiber, GLASdek<sup>®</sup>.
- The water-distribution has PVC tubing.
- The water-distribution hoses are of mesh-reinforced soft plastic with PVC couplings.
- The circulation pump impeller and pump housing are of plastic (PPS).
- The constant flow valve is of brass.
- Discharge pipe is of polyethylene tubing.



Munters Europe AB, HumiCool Division, Isafjordsgatan 1, P.O. Box 1150, SE-164 26 Kista, Sweden. Phone +46 8 626 63 00, Fax +46 8 754 56 66.  
www.munters.com

**Australia** Munters Pty Limited, Phone +61 2 6025 6422, **Brazil** Munters Brasil Industria e Comercio Ltda, Phone +55 41 3317 5050, **Canada** Munters Incorporated, Phone +1 905 858 5894,  
**China** Munters Air Treatment Equipment (Beijing) Co. Ltd., Phone +86 10 80 481 121, **Denmark** Munters Turbovent, Phone +45 9862 3311, **Finland** Munters Oy, Phone +358 9 83 86 030,  
**France** Munters France S.A., Phone +33 1 34 11 57 50, **Germany** Munters Euroform GmbH, Phone +49 241 89 00 0, **India** Munters India, Phone +91 20 3052 2520, **Indonesia** Munters, Phone +62 818 739 235,  
**Italy** Munters Italy S.p.A., **Chiusavecchia** Phone +39 0183-52 11, Munters Italy S.p.A., **Mondovi** Phone +39 0174 560 600, **Japan** Munters K.K., Phone +81 3 5970 0021,  
**Kingdom of Saudi Arabia and Middle East** Hawa Munters, Phone +966 1 241 8808, **Korea** Munters Korea Co. Ltd., Phone +82 2 761 8701, **Mexico** Munters Mexico, Phone +52 818 262 54 00,  
**Russia** Munters Europe AB, Phone +7 812 448 5740, **Singapore** Munters Pte Ltd., Phone +65 744 6828, **South Africa and Sub-Sahara Countries** Munters (Pty) Ltd., Phone +27 11 997 2000,  
**Spain** Munters Spain S.A., Phone +34 91 640 09 02, **Sweden** Munters Europe AB, Phone +46 8 626 63 00, **Thailand** Munters Co. Ltd., Phone +66 2 645 2708 12, **Turkey** Munters Form Endüstri Sistemleri A.Ş.,  
Phone +90 322 231 13 38, **United Kingdom** Munters Ltd., Phone +44 845 644 3980, **USA** Munters Corporation **Fort Myers** Phone +1 239 936 1555, Munters Corporation **Mason** Phone +1 888 335 0100,  
**Vietnam** Munters Vietnam, Phone +84 8 825 6838, **Export & Other countries** Munters Europe AB, Phone +46 8 626 63 00.