

STENNER PUMPS

PERISTALTIC METERING PUMPS SINCE 1957

BASIC SERVICE MANUAL

CLASSIC SERIES

CLASSIC SERIES

BASIC SERVICE MANUAL

The Stenner Classic Series peristaltic metering pumps are mechanical and during their service life will require scheduled maintenance. The purpose of this manual is to identify the parts that will eventually require replacement, along with other maintenance basics. Best practice tips and corrective actions are also covered.

IMPORTANT ICONS USED IN THIS MANUAL



Factory Instructions



Important Information



Additional Information

TABLE OF CONTENTS

SECTION I - GENERAL INFORMATION

SAFETY INFORMATION	5
TOOL LIST AND CLEANING SUPPLIES	6
CLASSIC SERIES PUMP	7

SECTION II - INSTALLATION POINTS

INSTALLATION DIAGRAM	8
VERTICAL INSTALLATION	9
SUCTION AND DISCHARGE LINES	10
COMPRESSION SEAL	11

SECTION III - SUBASSEMBLY CONNECTIONS

RIVET AND SLOT IDENTIFICATION	12
SEPARATING SUBASSEMBLIES	13
RECONNECTING FEED RATE TO MOTOR	14
RECONNECTING PUMP HEAD TO FEED RATE	15

SECTION IV - PUMP TUBE

PUMP TUBE	16
PUMP TUBE BASICS	17
VISUAL REFERENCE	18
CONDITIONS THAT REDUCE PUMP TUBE LIFE	19-22
PUMP TUBE REMOVAL, REPLACEMENT AND CENTERING	23-27
IMPORTANT PUMP TUBE INFORMATION	28

SECTION V - FEED RATE CONTROL (FRC)

FEED RATE CONTROL	29
FEED RATE WEAR	30-31
FEED RATE PARTS REPLACEMENT	32-33

SECTION VI - MOTOR

MOTOR	34
CAUSES OF MOTOR MALFUNCTION	35
ROTOR ASSEMBLY REPLACEMENT	36
COIL REPLACEMENT	37-40
GEARS	41
GEAR SET IDENTIFICATION	42
GEAR WEAR	43
GEAR REPLACEMENT	44

SAFETY INFORMATION

 **NOTICE:** Before installing or servicing the pump, read the pump manual for all safety information and complete instructions. The pump is designed for installation and service by properly trained personnel.



WARNING HAZARDOUS VOLTAGE:

DISCONNECT power cord before removing motor cover for service. **Electrical service by trained personnel only.**



WARNING HAZARDOUS PRESSURE/CHEMICAL EXPOSURE



Use caution and bleed off all resident system pressure prior to attempting service or installation.



Use caution when disconnecting discharge line from pump. Discharge may be under pressure. Discharge line may contain chemical.



WARNING RISK OF CHEMICAL EXPOSURE:

Potential for chemical burns, fire, explosion, personal injury, or property damage. To reduce risk of exposure, the use of proper personal protective equipment is mandatory.

TOOL LIST AND CLEANING SUPPLIES

- #2 Phillips head screwdriver
- Flat head screwdriver
- 3/8" open end wrench (to change index pin lifter)
- AquaShield®
- Fantastik® or similar (non-citrus) all purpose cleaner
- Needle-nose pliers
- Utility knife



CLASSIC SERIES METERING PUMP

THREE BASIC SUBASSEMBLIES

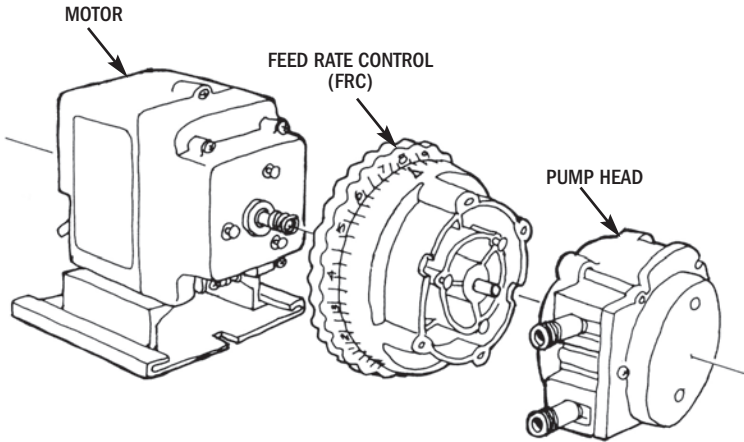

Use subassemblies in field for quick replacement.

INSTALLATION DIAGRAM

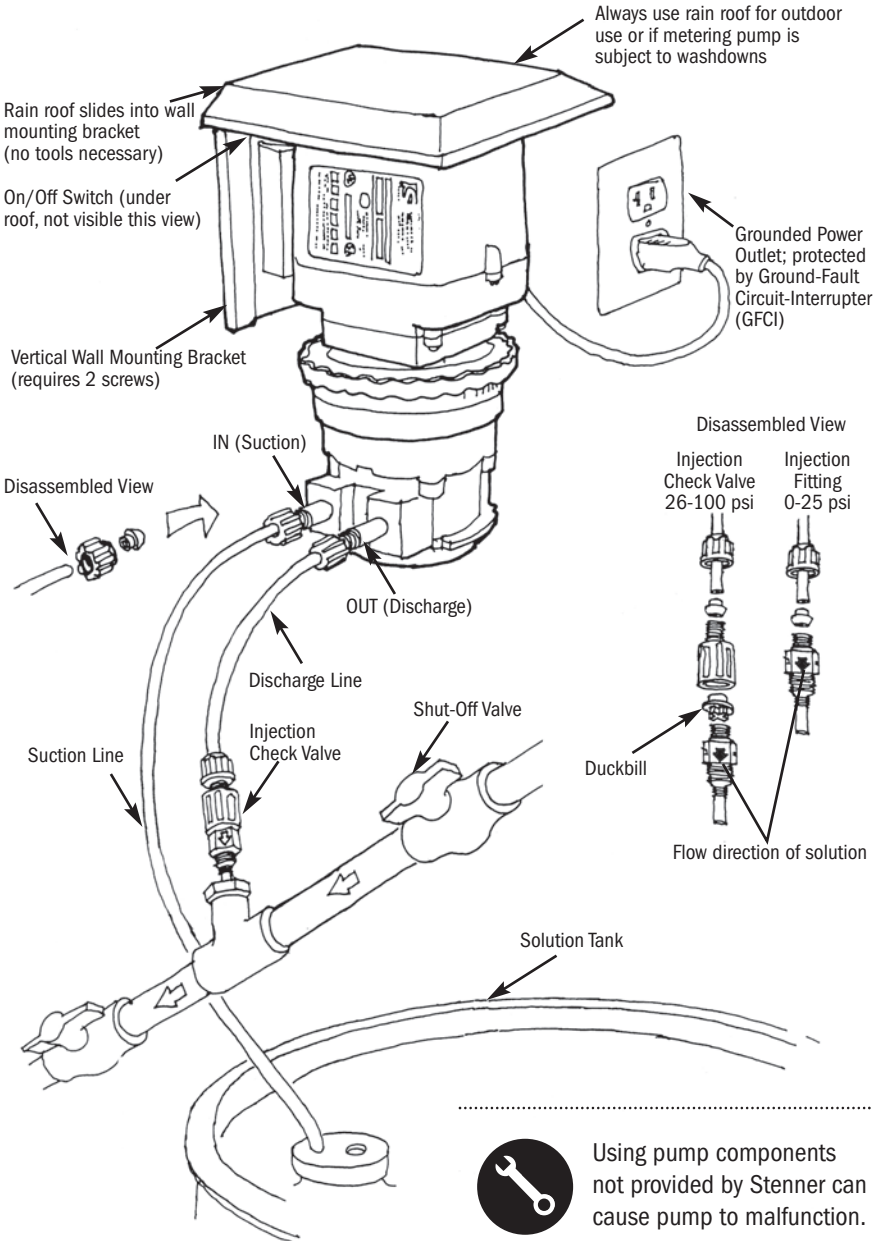

Using pump components not provided by Stenner can cause pump to malfunction.

VERTICAL INSTALLATION

Mount the pump vertically and use the spill recovery to drain chemical back to the tank in the event of tube failure. This will help prevent chemical from collecting in the tube housing and reduces spillage on the floor.

The pump motor is ventilated and water intrusion can cause motor damage. A rain roof is recommended for outdoor and wet environments.

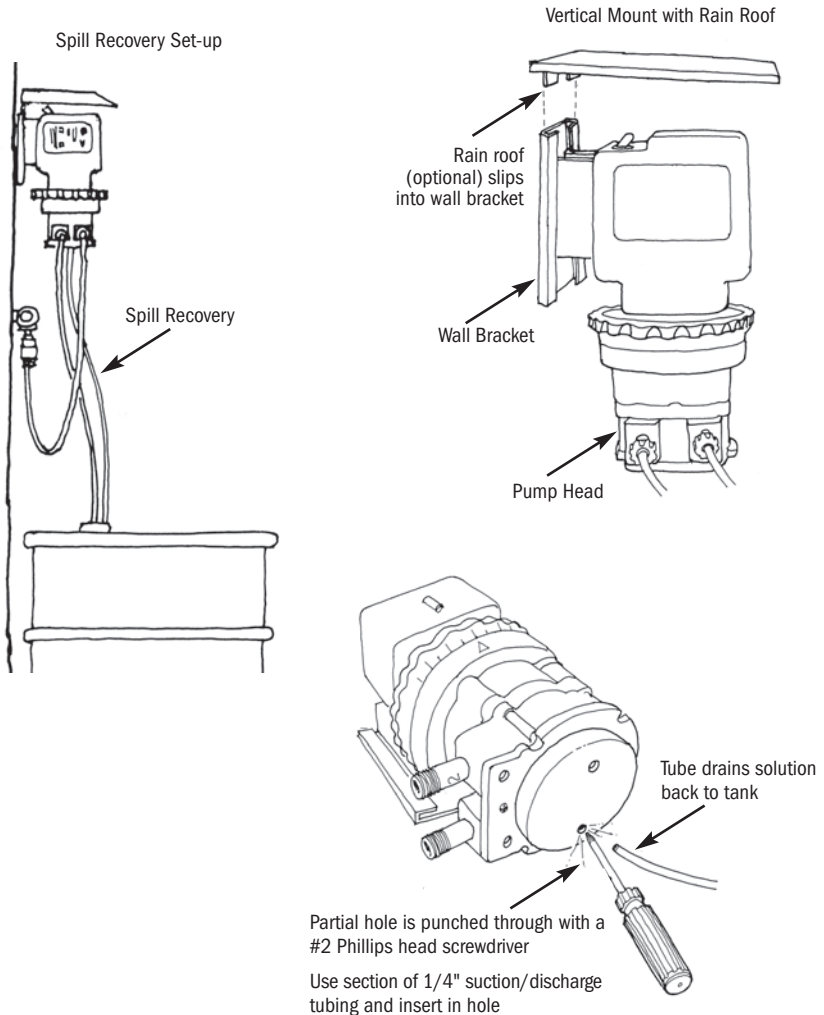

SUCTION AND DISCHARGE LINES

The suction line should be 3" from the tank bottom to prevent picking up sediment which can cause blockage in the check valve, duckbill and discharge line.

Allow slack in both the suction and the discharge lines so the pump tube fittings can flex. The slack prevents stress on the pump tube and fittings to help reduce the chance for breakage and leaks.

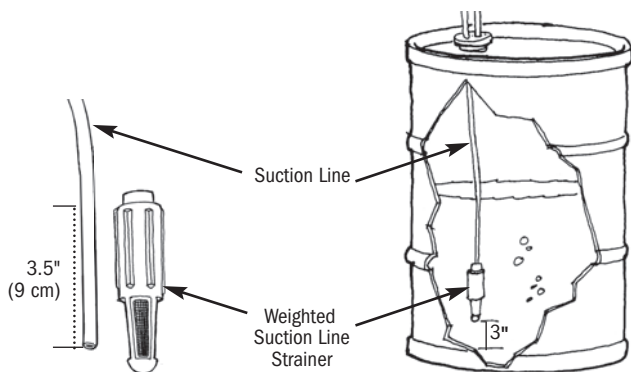

The suction line should not be inserted to the bottom of the weighted strainer. If the suction line becomes flush with the nose of the strainer, the pump may not prime due to blockage.



Use Stenner suction and discharge tubing, rain roof and UV gray tank for outdoor applications.

COMPRESSION SEAL

The suction and discharge lines are installed to the pump tube fittings with a compression type seal consisting of the connecting nut and ferrule. The beveled end of the ferrule should face the tube fitting and the suction and discharge lines should bottom into the tube fitting.

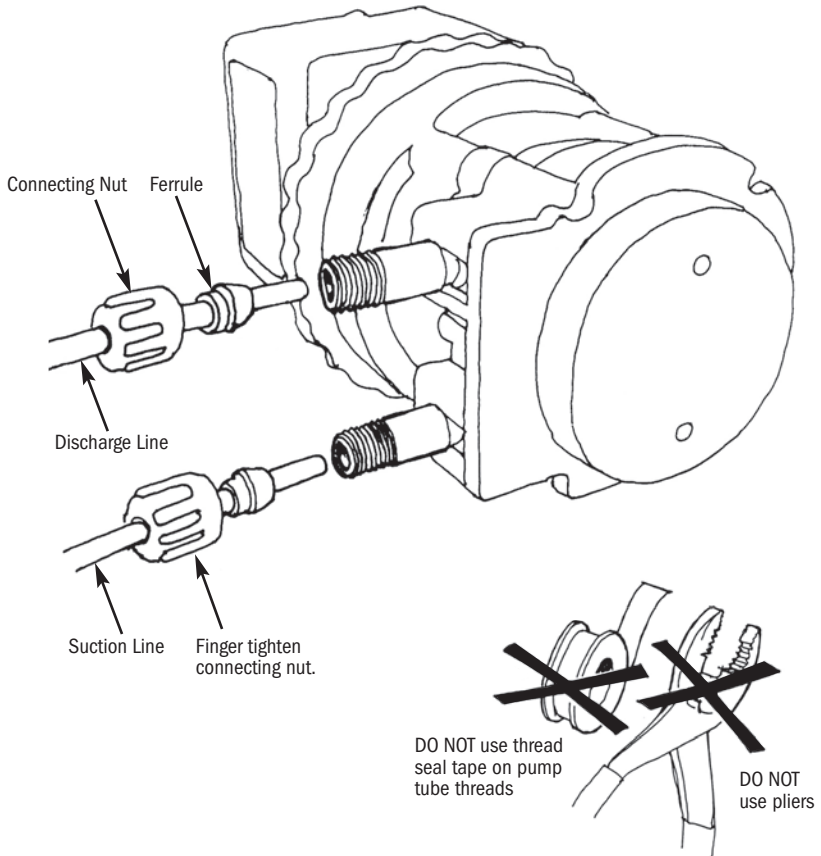

For 3/8" connections only. While stabilizing the tube fitting, attach female end of adapter to the tube fitting(s) (ferrule inside). Slide line through 3/8" connecting nut and finger tighten to male end of adapter. If leak occurs, gradually tighten the 3/8" connecting nut as required.

RIVET AND SLOT IDENTIFICATION

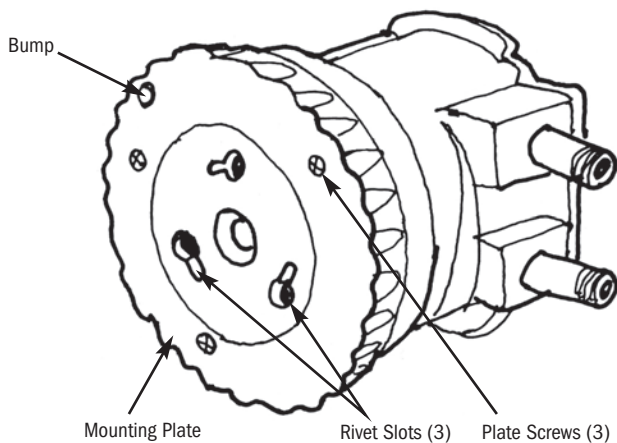
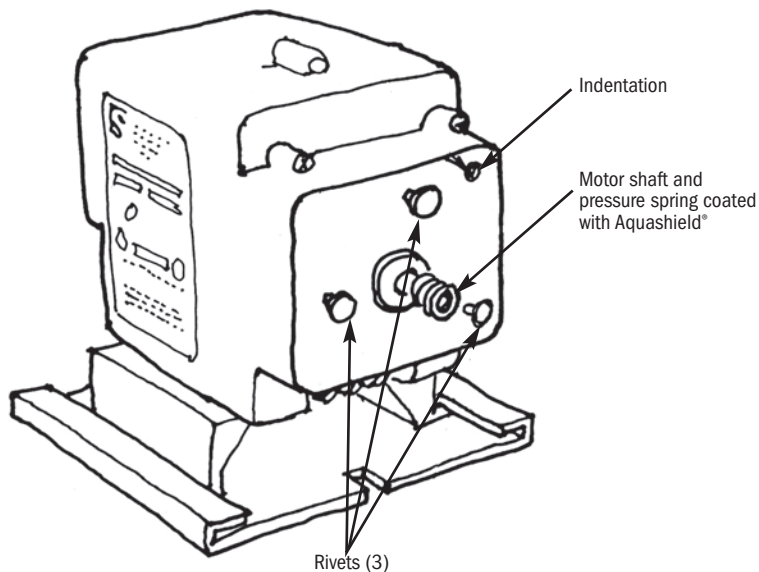

The pressure spring is not used with the fixed output pump.

SEPARATING SUBASSEMBLIES

1. Turn the pump off and unplug the power cord.
2. Hold the feed rate control section and turn the pump head clockwise until it stops.
3. Pull the pump head straight out.
4. Hold the motor assembly, grasp the feed rate control section and turn clockwise until it stops, and pull it straight out.

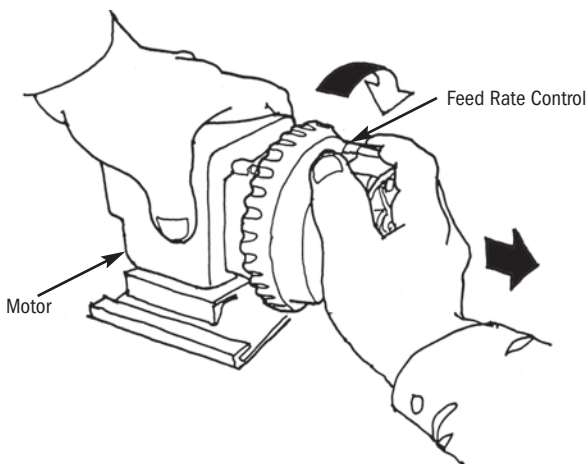
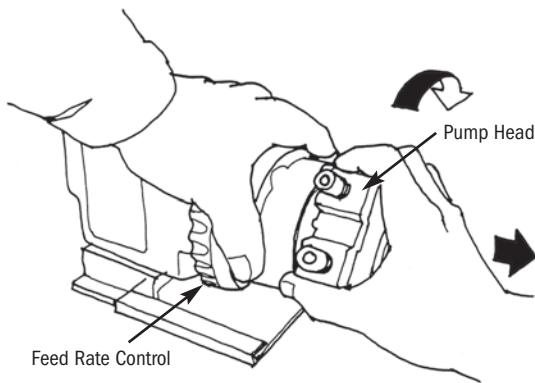

RECONNECTING FEED RATE TO MOTOR

1. Before reconnecting the feed rate control to the motor, confirm pressure spring is in place and place feed rate control on the shaft.
2. Turn the feed rate control counterclockwise to line up the flat side of the motor shaft (d shaft) with the flat side of the brass spider in the feed rate control and push towards the motor.
3. Push and turn the feed rate control until the rivets on the gear case are inside the rivet holes on the feed rate.
4. Turn counterclockwise until it locks into place and the bump on the feed rate mounting plate fits into the indentation in the gear case cover.

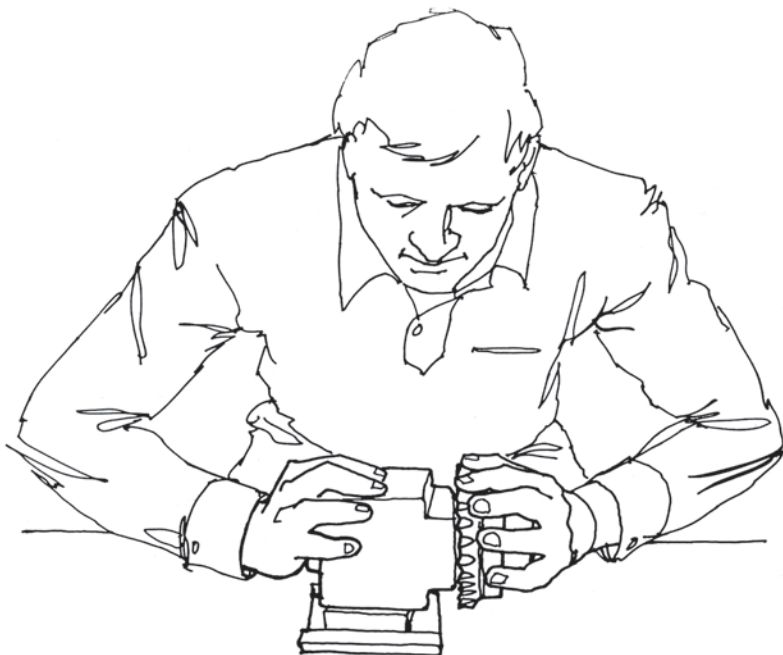

The arrow on the feed rate control should be on top and confirm the bump is in the indentation.

RECONNECTING PUMP HEAD TO FEED RATE

1. Put the pump head with main shaft into the feed rate control and turn it counterclockwise until the shaft falls into place.
2. Push the pump head toward the feed rate while turning it counterclockwise. Line up the rivet holes on the pump head with the rivets on the feed rate control.
3. Continue to push until the rivets are inside the holes and the snap lock engages.
4. Turn the pump head counterclockwise to secure the rivets in the rivet slots, firmly attaching the pump head.

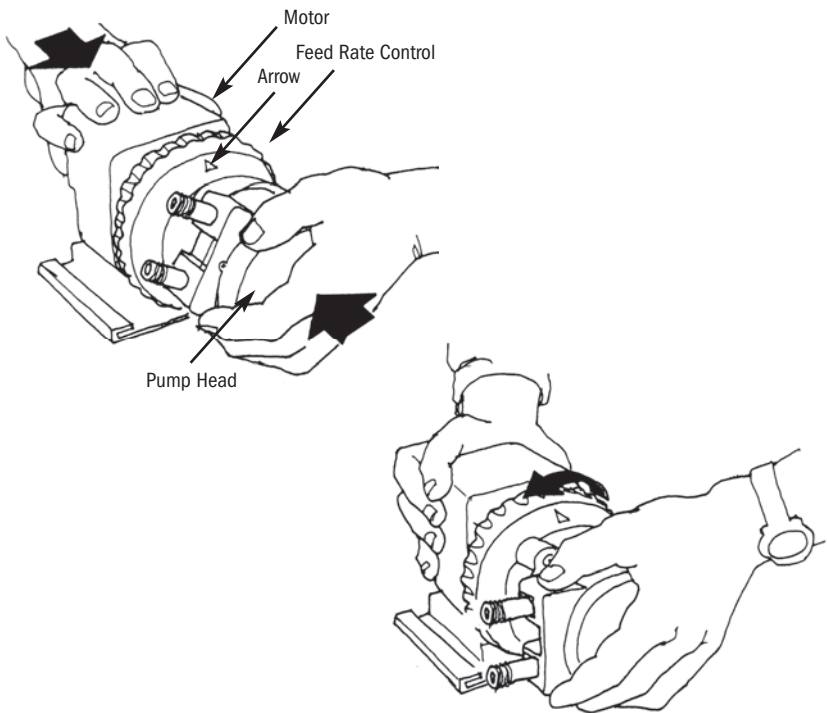
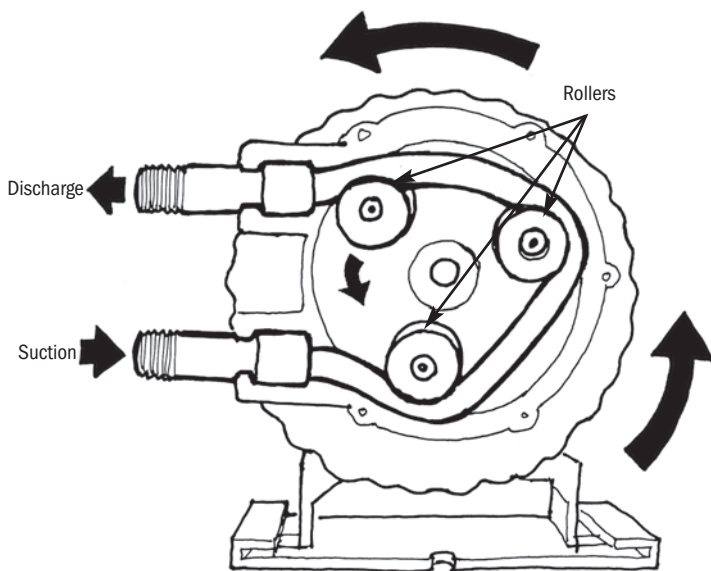

Illustration shows proper orientation of the pump head.

PUMP TUBE

Fluid is forced along by waves of contraction produced mechanically on flexible tubing. The tube is squeezed by two of the three rollers that move along the tube. As the roller moves, the compressed section generates a vacuum, creating a self-priming function. The remaining two rollers repeat the process and the rotation creates a pumping action that results in both suction lift and outlet pressure.



PUMP TUBE BASICS

The tube is the workhorse of the pump. It is perishable and will eventually stop functioning from natural wear or when it reaches the end of its service life. Indications of the end of service life are:

- Tube leaks
- Tube is fatigued causing a reduction or lack of output

The pump tube service life can be reduced by conditions of the application or the installation. These conditions are:

- Calcium or mineral deposits
- Sediment blockages
- Chemical incompatibility
- Corrosion
- Improper handling

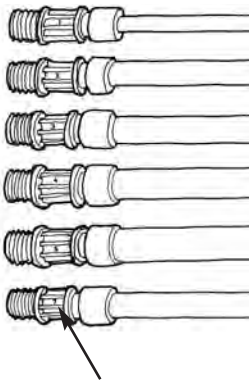

Tube number located on fitting

PUMP TUBE PRESSURE RATING

PUMP TUBE	0-25 psi (0-1.7 bar)	26-100 psi (1.8-6.9 bar) Check valve required
#1	✓	✓
#2	✓	✓
#3	✓	
#4	✓	
#5	✓	
#7*		✓

* Classic Single Head ONLY



For maximum pump tube life, always identify the reasons for the failure and correct the problem before a new tube is installed.

VISUAL REFERENCE

A diamond pattern that forms where the tube presses against the tube housing indicates excessive back pressure. Excessive back pressure can be caused by any blockage, a clogged duckbill or when the system pressure exceeds the pump tube pressure rating. An oval pattern indicates worn rollers and and/or the pump tube has reached the end of its service life. Pump tubes can rupture without either pattern apparent.

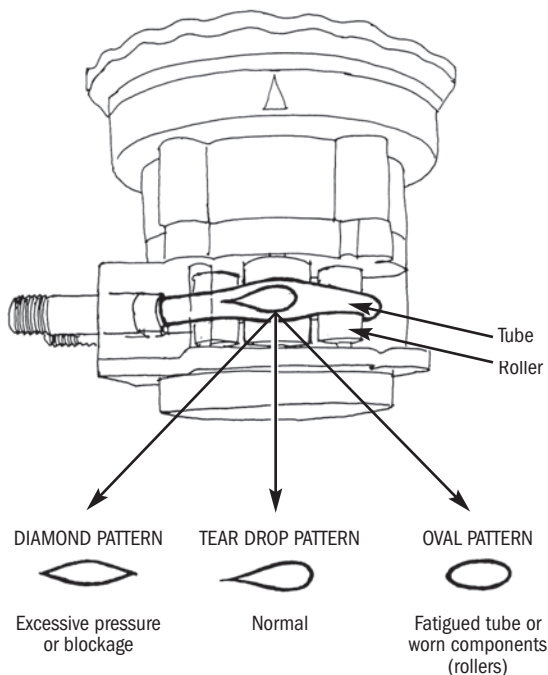

The most common tube problems are from a lack of routine maintenance. Always establish an application specific maintenance schedule.

CONDITIONS THAT REDUCE TUBE LIFE

IMPROPER TUBE HANDLING

- Not following factory tube replacement instructions.
- Storing tubes in high ambient temperatures or long term exposure to direct sunlight weakens tube material.
- Prior to installation, pre-stretching, lubricating the tube and/or roller assembly or pinching during installation, compromises the tube material.
- Excessive pulling of the tube fitting, during installation, can result in compromising the material. Allow the rollers to stretch tube into position according to the tube replacement instructions.
- Using pliers to center or secure connections can damage ferrules. The connecting nut must be finger tightened only.
- Using thread seal tape prevents ferrules from seating properly into tube fitting and can cause leaks.
- Not allowing enough slack in the suction and discharge lines so the tube fittings can flex puts stress on the tube and fittings.



DO NOT use thread seal tape or pliers on pump tube threads.



CONDITIONS THAT REDUCE TUBE LIFE continued

CRACKED PUMP HEAD

The tube housing can crack from wear, over tightening cover screws and long term chemical exposure due to incompatibility with the housing material (refer to *Chemical Resistance Guide*).

SEIZED ROLLERS IN THE ROLLER ASSEMBLY

Corrosive chemicals that collect on the roller bushings, as a result of atmosphere or tube failure, can result in seizing the rollers.

Corrective Action

1. Confirm chemical compatibility with housing and pump tube material.
2. Review factory recommended vertical pump installation.
3. In the event of tube rupture, rinse the chemical residue from the housing and roller assembly with factory recommended cleaners.
4. If tube housing is cracked, replace.

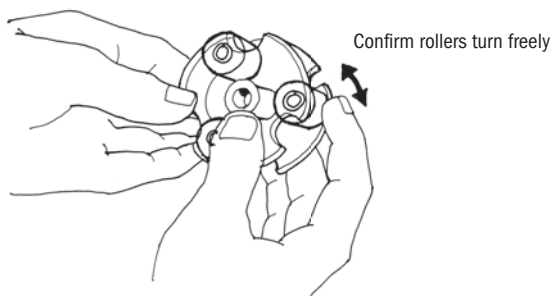

Normal roller wear can cause a lack of output as a result of the rollers' inability to fully squeeze the tube.

CONDITIONS THAT REDUCE TUBE LIFE continued

EXCESSIVE BACK PRESSURE AT THE POINT OF INJECTION

Calcium or mineral deposits in the injection fitting section of the check valve can cause blockage or restriction creating back pressure that exceeds the pump tube pressure rating.

Corrective Action

1. Insert a round shank screwdriver through injection fitting into the pipe to locate or break up accumulated deposits. If screwdriver can't be inserted, drill the deposit out of the injection fitting. Do not drill through the opposite pipe wall.
2. Replace duckbill.

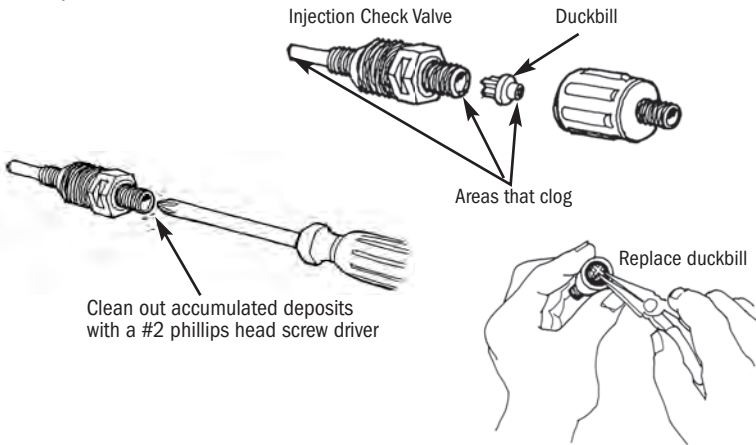

EXCESSIVE BACK PRESSURE AT THE POINT OF INJECTION

Insoluble sediments or particulates drawn through the suction line from the bottom of the tank can cause blockage or restriction in the check valve duckbill. These solids and excessive pressure can damage the pump tube.

Corrective Action

1. Replace suction and discharge tubing and clean sediment from tank bottom.
2. Position weighted strainer 3" from tank bottom.
3. Replace duckbill.



At every tube change, trim approximately 1" off the end of both the suction and discharge lines before installing new ferrules. Replace duckbill (26-100 psi applications) and ferrules with every new tube.

CONDITIONS THAT REDUCE TUBE LIFE continued

SPLIT ALONG SIDE OF THE TUBE

The tube rubbing against the edge of the tube housing can cause the side to split.

Corrective Action

Always follow the factory's tube replacement instructions which include centering the tube on the rollers.

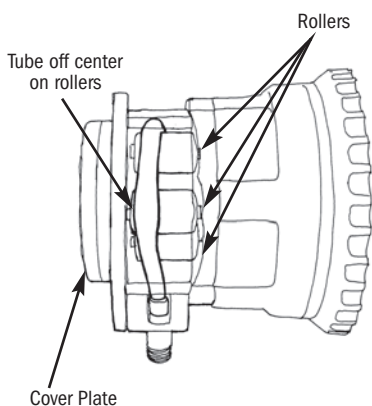

The tube will not center if it twists during installation or if the rollers are worn.



Refer to the Trouble Shooting guide in the *Classic Series Installation Manual* for more pump tube and pump head conditions and solutions.

REMOVE TUBE

1. Confirm pump is off. Remove and set aside cover and screws.
2. Set feed rate dial on setting L or 1.
3. Turn pump on and let it run until one of three roller assembly slots lines up with the tube fitting on the suction side.
4. Turn pump off.
5. Lift tube fitting out of housing slot and pull it toward center of roller assembly.
6. Turn pump on and allow roller assembly to jog while guiding tube, with tension, up and out of housing.
7. Turn pump off. Remove and discard pump tube.

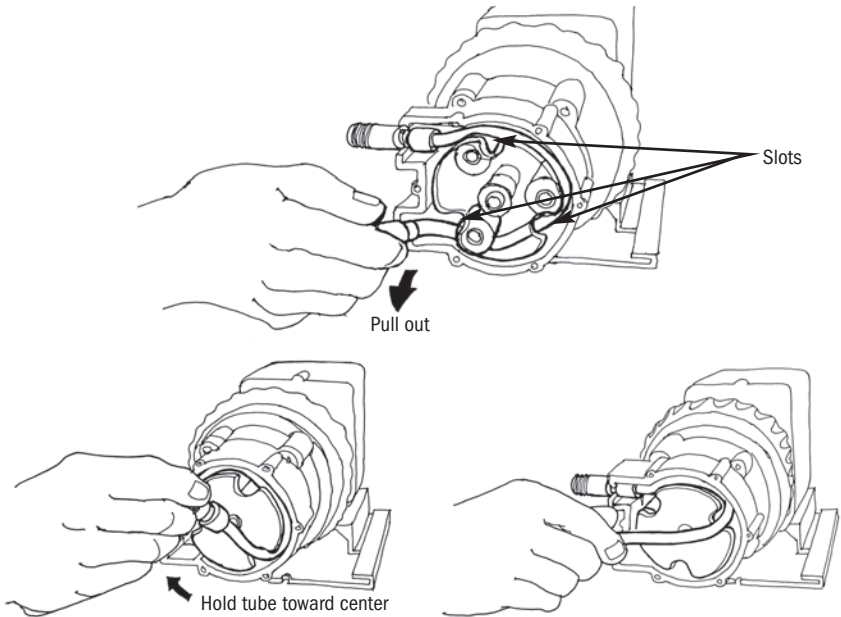

Prior to tube removal, pump water through tube to remove chemical.

REMOVE TUBE continued

8. Remove roller assembly, shaft, and housing.
9. Use non-citrus all-purpose cleaner to clean chemical residue from pump head housing, roller assembly and cover.
10. Check housing for cracks. Replace if cracked.
11. Ensure rollers turn freely. Replace roller assembly if the rollers are seized or worn or if there is a reduction or lack of output from the pump.
12. Reinstall clean tube housing. On an adjustable pump, install the shaft.
13. Apply AquaShield® to the shaft tip.
14. Install roller assembly.

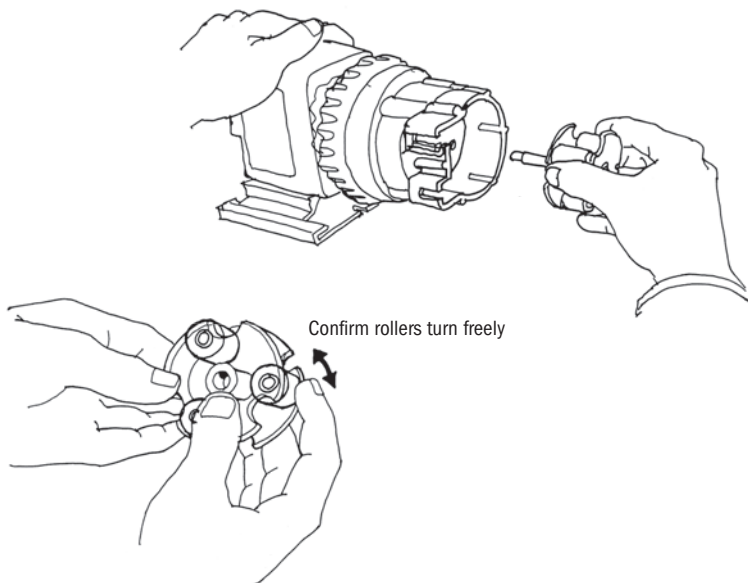

DO NOT lubricate pump tube or roller assembly.

INSTALL TUBE

1. Confirm the pump is off. Manually rotate the roller assembly counterclockwise to align one of three roller assembly slots with the suction side housing slot.
2. Place tube fitting into suction side slot of the housing and the roller assembly slot.
3. With pump setting on L, hold tube fitting and jog roller assembly by turning the pump on.

IMPORTANT! Avoid rotating wrist, which can result in a twisted tube that will not center.
DO NOT force tube and be careful of your fingers.

4. Guide tube with slight tension toward the center to prevent pinching between housing and roller assembly. If the tube is pinched during installation, discard.

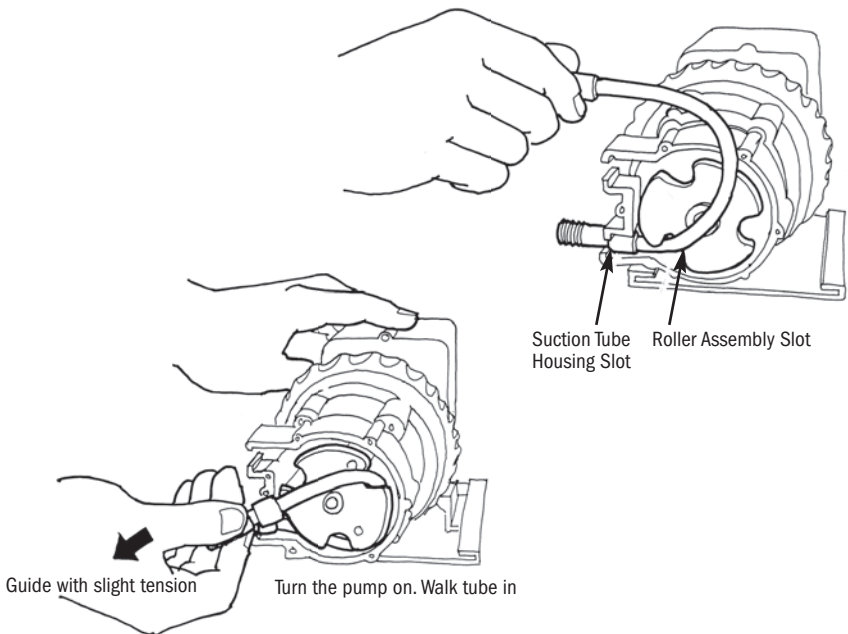

Identify the cause of tube failure prior to installing a new tube.



A used tube will have stretched approximately 3/4" and the new tube will appear to be stiff and short. Follow directions to allow rollers to stretch tube into place.

INSTALL TUBE continued

5. When tube reaches the discharge tube housing slot, turn pump off.
6. Turn dial ring to setting 10, hold tube fitting firmly, do not pull, and turn pump on.
7. Allow rollers to stretch tube into place while guiding tube into slot.
8. Turn pump off.
9. Apply a small amount of AquaShield® to cover bushing ONLY and replace cover and two screws. Leave the front screw between the fittings loose for centering the tube in the next step.

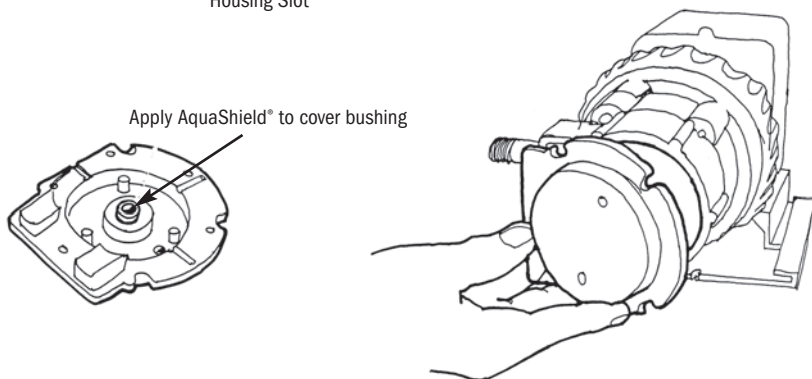
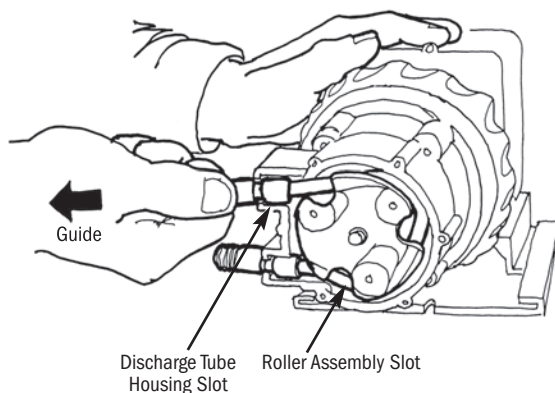

Cover screws are self-tapping and must be backed in to locate original threads before securing. If a screw boss is stripped, use alternate bosses and position opposite from each other. Never secure the cover plate with more than 2 screws.

CENTER TUBE

1. To center pump tube on rollers, set feed rate dial to setting 10. Turn pump on.
2. Turn the tube fitting on the suction side not more than 1/8 of a turn in the direction tube must move.
3. DO NOT let go of fitting until tube rides approximately in center of rollers.
4. Turn pump off, let go of fitting, and finger tighten cover screws.
5. Inspect the suction and discharge lines, point of injection, and check valve duckbill for blockages. Clean and/or replace as required.
6. Reconnect the suction and discharge lines.

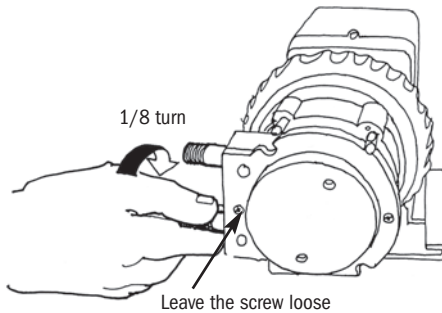

TUBE CHANGE FOR FIXED OUTPUT PUMP

To install a new tube in a fixed output pump, follow the instructions for the adjustable pump and utilize the on/off switch to jog the roller assembly in the absence of the feed rate control.

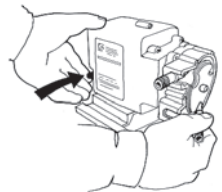

At every tube change, trim approximately 1" off the end of both the suction and discharge lines before installing new ferrules. Replace duckbill (26-100 psi applications) and ferrules with every new tube.

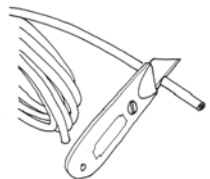

IMPORTANT TUBE INFORMATION

- Always follow factory tube replacement and centering instructions.
- Schedule a tube replacement at regular intervals according to the needs of the specific application.
- A used tube will have stretched approximately 3/4" and the new tube will appear to be stiff and short. Follow directions to allow rollers to stretch tube into place.
- Replace ferrules with every tube change, ferrules are the seal between the tube fitting and the connecting nut.
- Only finger tighten the connecting nut. Hold the tube fitting when tightening to prevent breaking the internal seal and the fitting from spinning inside the tube.
- For 26-100 psi applications, inspecting and replacing the duckbill at every tube change is recommended.
- Santoprene® pump tubes are not compatible with petroleum or oil-based products. Refer to the chemical resistance chart for compatibility or call the factory.



For maximum tube life, always identify the reasons for the failure and correct the problem before a new tube is installed.

FEED RATE CONTROL (FRC)

The feed rate control adjusts the output by utilizing a cam and spring loaded lifter system to control the rotation of the roller assembly according to the setting on the dial ring.

Inside the FRC is a brass spider assembly that consists of a pin with carbide tip and spring inside the holder attached to a lifter.

When the pump is on, the spider assembly rotates. When the lifter drops into the FRC channel, the pin engages the index plate rotating the roller assembly creating the pumping action.

When the lifter rides on the cam, the pin is lifted inside the holder. The roller assembly does not rotate, resulting in no pumping action.

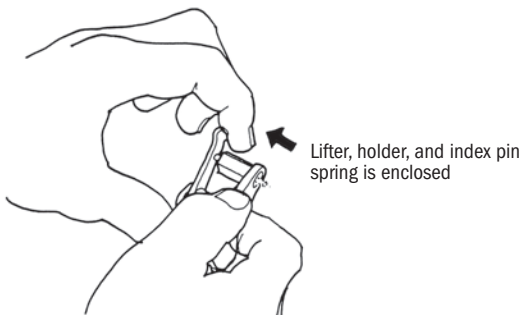
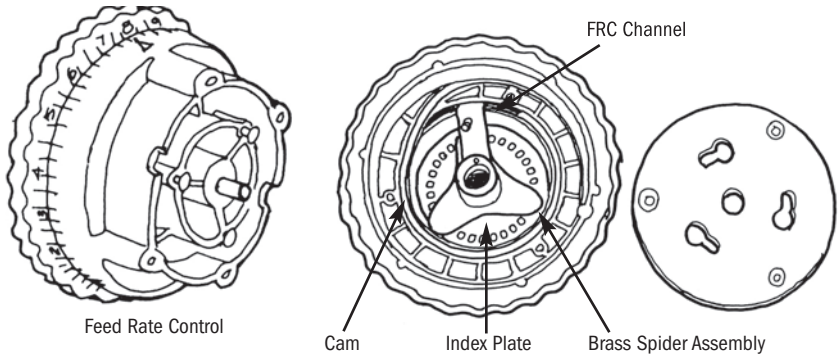

Index pin retracts when lifted.

FEED RATE CONTROL WEAR

Indication of wear is apparent when the feed rate control makes a skipping or ratcheting sound. The pump output is less than the desired setting.

GROOVE IN CAM

More cam is exposed to the rotation of the lifter at lower dial ring settings leading to cam wear and causing index malfunctioning. Higher settings will reduce cam wear. Inspect and replace cam as needed.

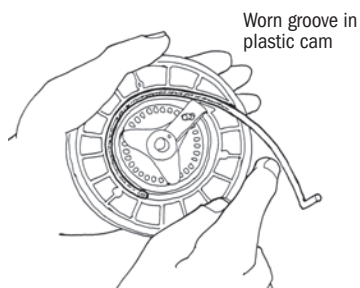

WORN LIFTER

If the lifter arm wears and flattens it may not fully lift the pin out of the index plate. The pin will make a ratcheting sound from dragging across the plate. The feed rate control will index inconsistently at different settings. Replace the lifter as needed.

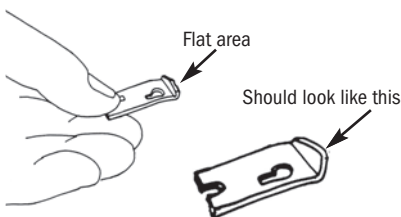

WORN INDEX PLATE

A worn cam or lifter can cause the index pin to drag across the index plate and elongate the holes. The pin will skip across the holes and cause index malfunction. The plate can be flipped to use the other side, or it may be replaced. Remember to grease with AquaShield®.

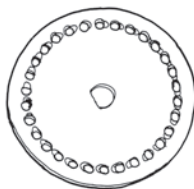

Index plate with elongated holes

Corrective Action

To reduce wear on the feed rate parts, specify the pump closest to its maximum output capacity within the needs of the application. Check the lifter, cam and index plate during scheduled maintenance.

FEED RATE CONTROL WEAR continued

SEIZED INDEX PIN AND/OR LIFTER ASSEMBLY

Water or chemical intrusion will corrode the pin and lifter causing them to seize; the feed rate will malfunction.

Corrective Action

1. Replace the index pin and/or lifter assembly as needed.
2. Review the factory recommended vertical installation.
3. Schedule a pump tube replacement at regular intervals according to the specific application. For 26-100 psi applications replace the duckbill at every tube change.

PARTS REPLACEMENT

1. Remove and set aside:
 - Three screws
 - Feed rate mounting plate
 - Dial ring (observe installed cam)
 - Brass spider assembly
 - Index plate
2. If required, remove index pin assembly by unscrewing with a 3/8" wrench and replace.
3. Flip worn index plate over OR install new index plate.
4. Clean out FRC channel before installing new cam.
5. Apply AquaShield® to lubricate the cam's angled tip.
6. To install the cam, feed the angled cam tip into the FRC channel and keep the 90° end in the up position. Place thumb over the cam to guide as it is inserted in the channel.
7. Continue to feed the cam in the channel until there is approximately a 1/2" gap between the cam tip and the beginning of the channel.

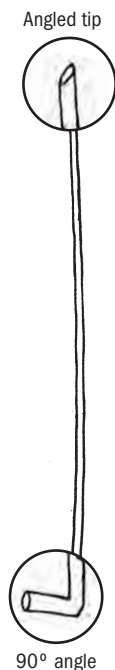
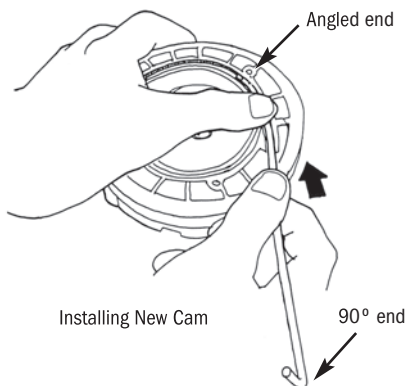
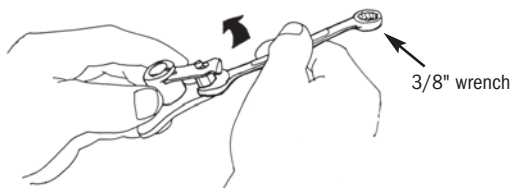

PARTS REPLACEMENT continued

8. Apply AquaShield® to the inside of the dial ring for easier turning.
9. Place dial ring boss onto the cam's 90° end.
10. While keeping the 90° end in the boss and the cam in the FRC channel, in a clockwise motion, place the dial ring onto the FRC housing and snap into place.
11. Apply AquaShield® to bottom of the FRC housing before placing index plate inside. Apply AquaShield® to the top of the index plate.
12. Place the spider assembly on the index plate. The lifter tip should be positioned in the 1/2" gap in the FRC channel.
13. To secure mounting plate, align its arrow with the FRC housing arrow and install the three screws.

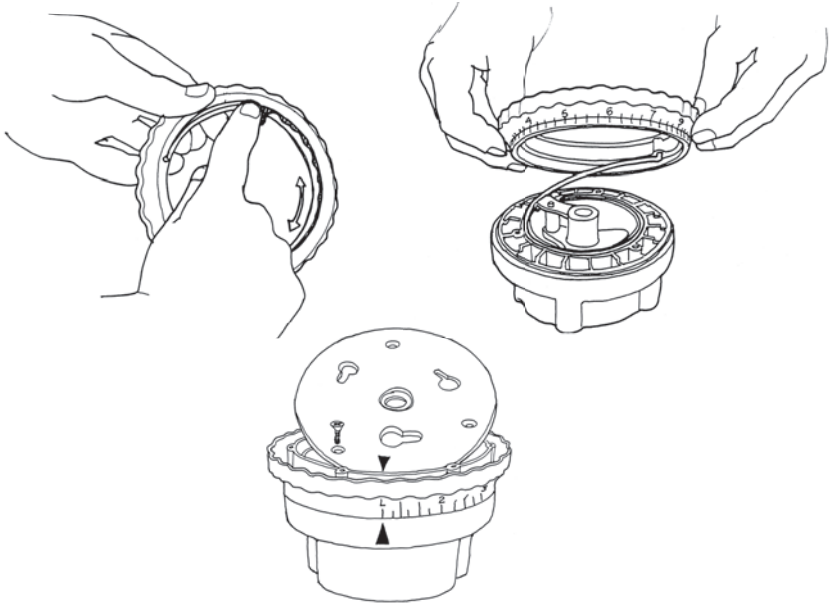

If the dial ring does not rotate from L to 10, the FRC mounting plate is in the wrong orientation.



The dial ring will be stiff or difficult to rotate if it lacks AquaShield® or the screws are over tightened. If the screws are too loose, the dial ring can inadvertently be turned to setting 10 by the motor.

MOTOR

The motor has a cylindrical rotor with shaft that is encased within a magnetic coil. When power is applied to the coil, the rotor rotates. The rotor's directional rotation is determined by the orientation of the copper shaded poles on the coil. The helical end of the rotor engages the series of gears in the gear case.

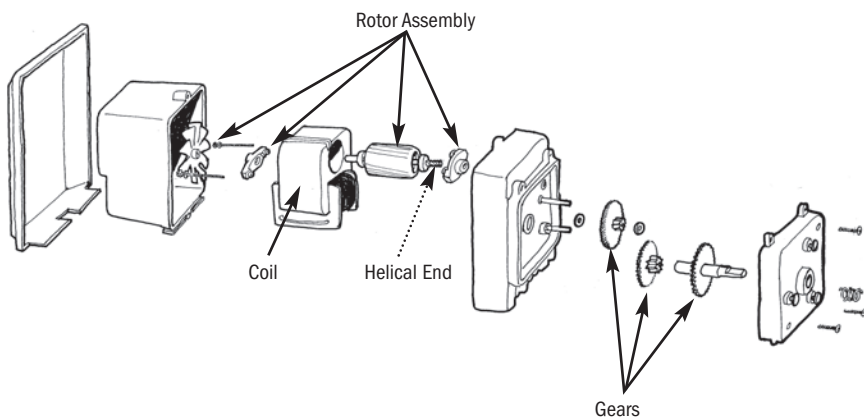
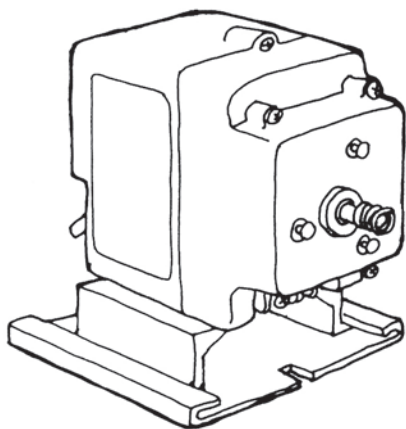

CAUSES OF MOTOR MALFUNCTION

WATER INTRUSION

The motor is fan cooled and needs proper ventilation while protecting it from water intrusion.

Corrective Action: Mount the single head pump vertically with pump head downward and use the rain roof in outdoor installations, in areas subject to wash downs, or in moist environments.

CHEMICAL VAPORS

The motor won't be able to rotate freely if the coil, rotor and bearing are rusted or corroded.

Corrective Action:

1. Avoid mounting the pump over an open solution tank.
2. Review vertical installation.

INCORRECT VOLTAGE

The motor voltage must match power supply to avoid a burned coil.

Corrective Action: Use a volt meter for confirmation.

DAMAGED BEARING BRACKETS

Cracked or broken bearing bracket(s) result in rotor mis-alignment that can cause the rotor to bind to the magnetic coil that may be evident by a humming sound.

Corrective Action:

1. Check the condition of the brackets and phenolic gear.
2. Replace parts as needed.



Refer to the Trouble Shooting guide in the *Classic Series Installation Manual* for motor conditions and solutions.

ROTOR ASSEMBLY REPLACEMENT

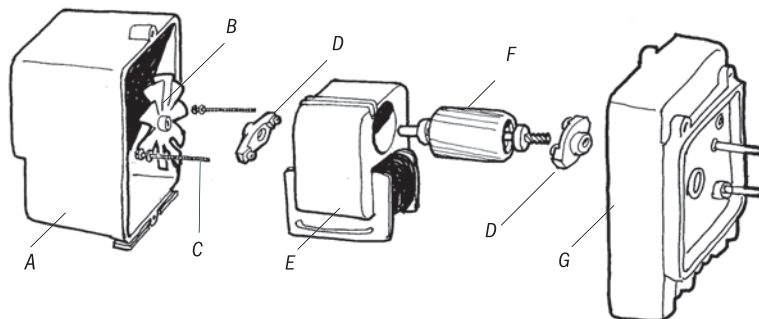

A rotor assembly includes B, D & F.

1. Remove and set aside:
 - Two motor housing screws (not shown)
 - Motor housing A
 - Plastic fan B (discard old fan)
 - Two coil screws and lock washers C
 - Coil (keep wires connected) E
2. Remove and discard the rotor F and two amber bearing brackets D.
3. Press the new amber bearing bracket D onto the threaded brass inserts in the back of the gear case G.
4. Install the new rotor F by inserting the shaft (helical gear side) onto the amber bearing bracket D.
5. Place the coil E (see Correct Coil Orientation) over the rotor F onto the bearing bracket D.
6. Snap into place the second bearing bracket onto the rotor.
7. Insert two coil screws with lock washers C and tighten.
8. Starting at an angle, press fan B (with hub side down) onto the rotor shaft.
9. Reinstall the two motor housing screws and tighten the self-tapping screws to secure the motor housing A.

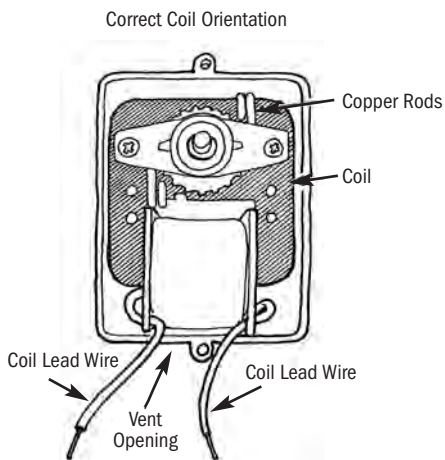

COIL REPLACEMENT

1. Disconnect power to pump.
2. Remove motor base. Remove two motor cover screws.
3. Invert the pump and use the pump head and feed rate control as a stand to work on the motor. See illustration.
4. Remove fan and set aside.

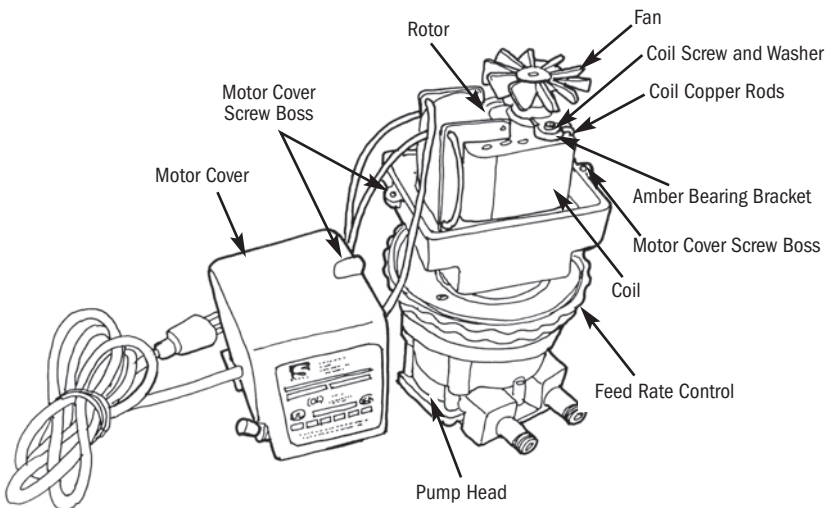
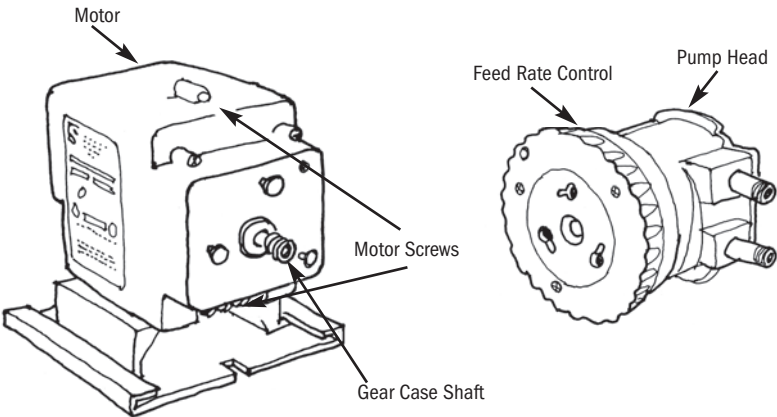

COIL REPLACEMENT continued

5. Disconnect ground wire (with eyelet) and set screw aside.
6. Cut the power cord and coil lead wires from motor cover at the wire nut (four cuts total). Set cover to the side.
7. Remove and set aside:
 - Two coil screws and washers from the rotor bracket
 - Plastic amber bearing bracket
8. Remove coil and discard.

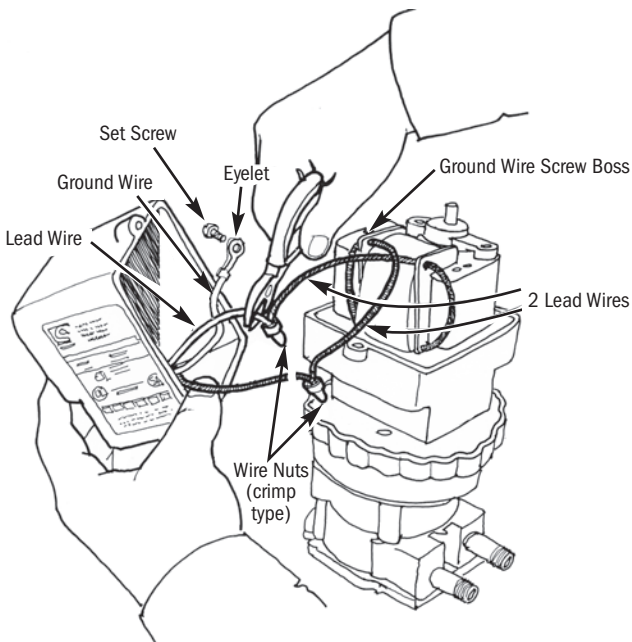

COIL REPLACEMENT continued

9. Install new coil over rotor on the remaining amber bracket. The correct orientation is with two copper rods in the upper right corner and the vent opening at the bottom of the gear case. Place bracket back on the rotor and securely seat into new coil. Install screws and washers and fasten bracket to coil.
10. With the metal band facing the bracket, press fan flush on rotor shaft.

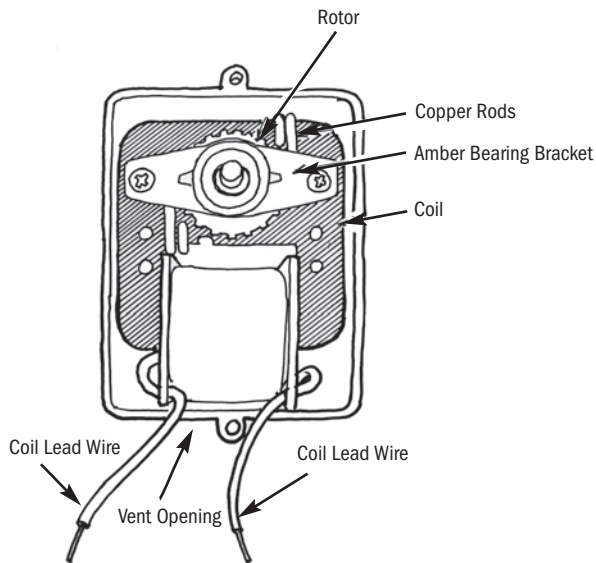

COIL REPLACEMENT continued

11. With wire strippers set at 16 gauge, strip approximately 1/2" from the power cord and on/off switch lead wires in the motor housing.
12. Secure ground wire (with eyelet) to motor coil.
13. Crimp the stripped lead wires to each of the new coil lead wires.
14. Tuck wire nuts into bottom of motor cover and secure cover back in place (before tightening, reverse cover screws to catch original threads).
15. Apply power to motor and test.

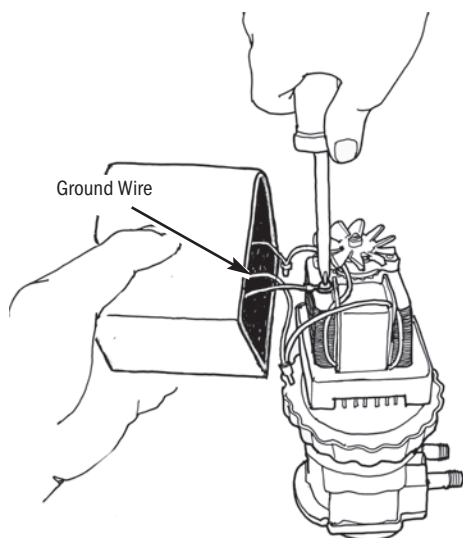
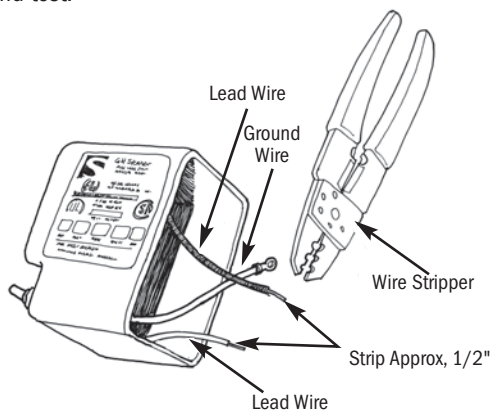

GEARS

Located in the gear case, the metal reduction gear and phenolic gear control the rpm of the feed rate and pump head. The 45 and 100 series delivers approximately 26 rpm and approximately 44 rpm for the 85 and 170 series. The motor shaft with gear drives the feed rate control.

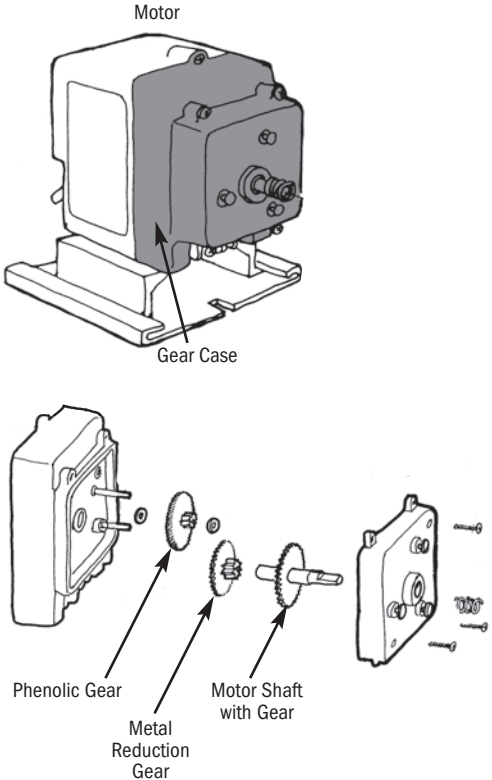

GEAR SET IDENTIFICATION

The illustrations show the diameters of the gears and pinions.

45 & 100 SERIES GEARS

Phenolic Gear

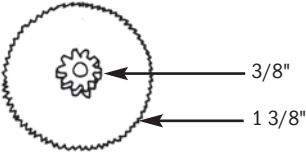

Metal Reduction Gear

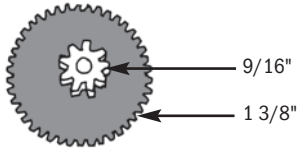

85 & 170 SERIES GEARS

Phenolic Gear

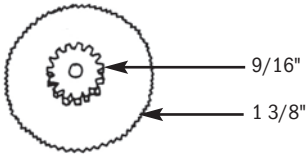

Metal Reduction Gear

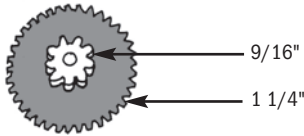

GEAR WEAR

Generally, gear failure can be caused by misalignment mainly due to the wear over the service life of the pump.

Check for the following conditions that can contribute to the phenolic gear stripping.

- Water or chemical intrusion
- Cracked bearing bracket
- Worn gear posts
- Worn gear case cover
- Rusted helical gear
- Insufficient lubrication

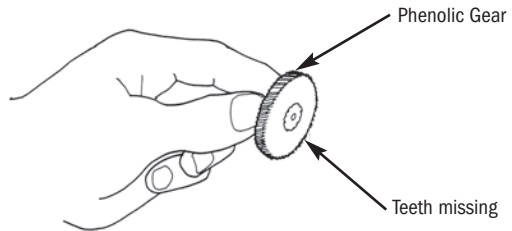

Corrective Action:

1. Review the vertical installation that includes using a rain roof in outdoor applications or wet environments.
2. Replace gears that show visible wear or corrosion.
3. Replace gear posts that are worn, rusted or corroded.
4. Inspect the gear case and cover for cracks or corrosion and replace as needed.
5. Inspect the helical gear at the end of the rotor. Buff off the rotor if rusted or replace the rotor assembly.
6. Lubricate with AquaShield®.



Apply a generous amount of AquaShield® to gear posts, pinions, gear rings and the main shaft with gear after doing service in the gear case.

GEAR REPLACEMENT

1. Remove four Phillips head screws from gear case cover.
2. Remove gear case cover.
3. Remove gears and inspect posts. To remove posts, grasp with pliers and pull straight out.
4. Wipe away old grease, check for rust or corrosion on the rotor shaft and remove with wire brush any visible rust or corrosion prior to replacing gears.
5. Install gear posts by tapping with rubber mallet until bottomed.
6. Apply AquaShield® on new gear posts before installing gears.
7. Install phenolic gear and spacer.
8. Install metal reduction gear and motor shaft with gear.
9. Use remaining AquaShield® on top of the three gears.
10. Re-attach gear case cover and four new screws, finger tighten the screws. Screws must be backed in to locate original threads before securing, to prevent stripping screw boss.

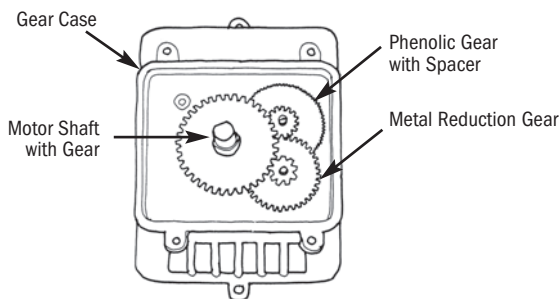
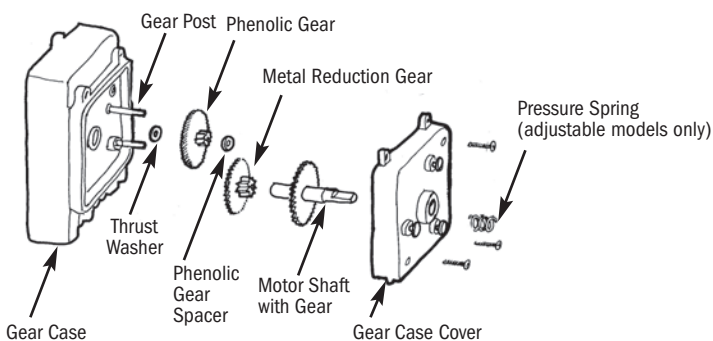





STENNER PUMP COMPANY

3174 DeSalvo Road
Jacksonville, Florida 32246

Phone: 904.641.1666

US Toll Free: 800.683.2378

Fax: 904.642.1012

sales@stenner.com

www.stenner.com

Hours of Operation (EST):

Mon.-Thu. 7:30 am-5:30 pm

Fri. 7:00 am-5:30 pm



Stenner products are proudly made in the USA

© Stenner Pump Company
All Rights Reserved

Illustrations by David Stiles
www.stilesdesigns.com