

Wexiödisk^W

RACK CONVEYOR DISHWASHER WD-151E - WD-421E

(translation of the original documentation)

Installation and user manual

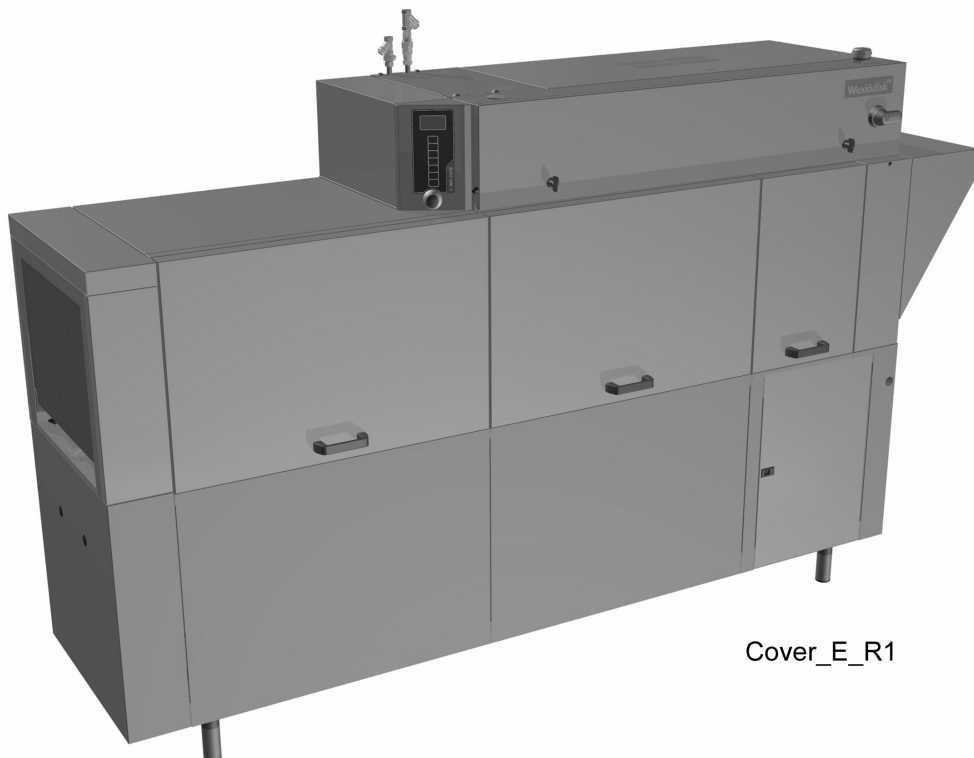

Cover_E_R1

| | |
|---|----------|
| 1. General information | 1 |
| 1.1 Symbols used in this manual | 1 |
| 1.2 Symbols on the dishwasher | 2 |
| 1.2.1 Machine marking | 2 |
| 1.3 Checking that the machine and the manual correspond | 2 |
| 2. Safety instructions | 3 |
| 2.1 General information | 3 |
| 2.2 Transport | 3 |
| 2.3 Installation | 3 |
| 2.4 Detergent and drying agent | 4 |
| 2.5 Operation | 4 |
| 2.5.1 Crushing risk | 4 |
| 2.5.2 Risk of slipping | 4 |
| 2.6 Cleaning | 4 |
| 2.6.1 Pressure washing | 4 |
| 2.6.2 The outside of the machine | 4 |
| 2.6.3 Cleaning the floor | 5 |
| 2.7 Repairing and servicing the dishwasher | 5 |
| 2.7.1 Safety instructions if the machine is not functioning | 5 |
| 2.8 Recycling the machine | 5 |
| 3. Installation | 6 |
| 3.1 General information | 6 |
| 3.2 Requirements for the installation site | 6 |
| 3.2.1 Lighting | 6 |
| 3.2.2 Ventilation | 6 |
| 3.2.3 Drains | 6 |
| 3.2.4 Space for servicing | 6 |
| 3.3 Transport and storage | 7 |
| 3.4 Unpacking | 7 |
| 3.5 Recycling the packaging | 7 |
| 3.6 Installation | 8 |
| 3.6.1 Positioning the machine | 10 |

| | |
|---|-----------|
| 3.7 Connections | 11 |
| 3.7.1 Electrical connection | 12 |
| 3.7.2 Water connection | 12 |
| 3.7.3 Steam connection (option) | 12 |
| 3.7.4 Drain connection | 13 |
| 3.7.5 Ventilation | 13 |
| 3.7.6 Installing extra equipment | 13 |
| 3.7.7 Setting the flows | 14 |
| 3.8 Installing detergent and drying agent equipment | 16 |
| 3.8.1 Electrical connection of the equipment | 17 |
| 3.8.2 Detergent dosing system | 18 |
| 3.8.3 Drying agent dosing system | 19 |
| 3.9 Trial run | 20 |
| 3.9.1 Start-up schedule | 20 |
| 3.10 Technical documentation | 22 |
| 4. Instructions for use | 23 |
| 4.1 Preparations | 23 |
| 4.1.1 The machine's design | 23 |
| 4.1.2 Preparations before filling | 25 |
| 4.1.3 Filling and heating the machine | 25 |
| 4.1.4 Filing and heating the machine using timer start (option) | 26 |
| 4.2 Using the machine | 27 |
| 4.2.1 Washing | 27 |
| 4.2.2 Guaranteed final rinse | 28 |
| 4.2.3 Emergency stop | 30 |
| 4.2.4 Changing the water | 30 |
| 4.3 After use – cleaning | 30 |
| 4.3.1 Daily cleaning | 31 |
| 4.3.2 Cleaning and checking each week or as required | 32 |
| 4.3.3 Cleaning in the event of an alarm or once a year | 33 |
| 4.3.4 Operating problems | 35 |
| 5. Technical information | 39 |

1. General information

Read the instructions in this manual carefully as they contain important information regarding the correct, effective and safe installation, use and servicing of the dishwasher.

Keep this manual in a safe place so that it can be used by other operators of the dishwasher.

The electronics in the machine are RoHS compatible.

1.1 Symbols used in this manual



This symbol warns of situations where a safety risk may arise. The instructions given should be followed in order to prevent injury.



This symbol on a component is a warning of electrical equipment. The machine is sensitive to electrostatic discharge (ESD), which is why a static electricity wristband must be used when handling the electronics.



This symbol explains the correct way to perform a task in order to prevent poor results, damage to the dishwasher or hazardous situations.



This symbol identifies recommendations and hints to help you to get the best performance from the machine.



This symbol explains the importance of careful and regular cleaning of the machine to meet hygiene requirements.

General information

1.2 Symbols on the dishwasher



This symbol on a component is a warning of electrical equipment. The component may only be removed by a qualified electrician. The machine is sensitive to electrostatic discharge (ESD), which is why a static electricity wristband must be used when handling the electronics.

1.2.1 Machine marking

The machine has two rating plates, one of which is placed at the bottom of one side of the machine and the other in the electrical cabinet. The technical information on the plates is also included on the machine's wiring diagram. The various rating fields show:

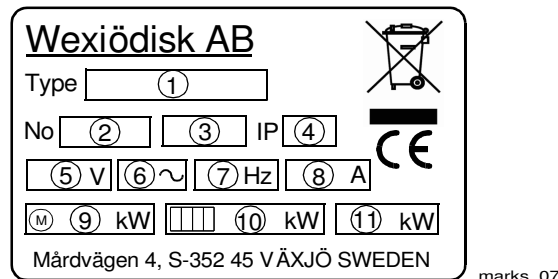

1. Machine type
2. Machine serial number
3. Year of manufacture
4. Enclosure protection class
5. Voltage
6. Number of phases with or without zero
7. Frequency
8. Main fuse
9. Motor output
10. Electrical heat output
11. Max. output

1.3 Checking that the machine and the manual correspond

Check that the type description on the rating plate corresponds with the type description on the front of the manual. If manuals are missing, it is possible to order new ones from the manufacturer or the local distributor. When ordering new manuals, it is important to quote the machine number found on the rating plates.

2. Safety instructions

2.1 General information

The machine is CE marked, which means that it complies with the requirements of the EU machinery directive with regard to product safety. Product safety means that the design of the machine will prevent personal injury or damage to property.



Modifying the equipment without the approval of the manufacturer invalidates the manufacturer's product liability.

To further improve safety during installation, operation and servicing, the operator and the personnel responsible for installing and servicing the machine should read the safety instructions carefully.



Switch off the machine immediately in the event of a fault or malfunction. The machine must only be serviced by trained engineers. The regular checks described in the manual must be carried out in accordance with the instructions. The machine must be serviced by a person authorised to do so by the manufacturer. Use original spare parts. Contact an authorised service company to draw up a programme of preventative maintenance. Dangerous situations may arise if the instructions above are not followed.

Before using the machine, ensure that personnel are given the necessary training in operating and maintaining the machine.

2.2 Transport



Handle the machine with care during unloading and transport to avoid the risk of it tipping over. Never lift or move the machine without using the wooden packaging to support the stand.

2.3 Installation



This symbol on a component is a warning of electrical equipment. The machine is sensitive to electrostatic discharge (ESD), which is why a static electricity wristband must be used when handling the electronics.



Water and steam pipes must only be connected by authorised personnel.



Water pipes must be connected in a way that complies with the current regulations of the local water supply authority. Check that the water and steam connections are tight before operating the machine.

Make sure that the mains voltage is the same as that indicated on the machine's rating plate.

Safety instructions

2.4 Detergent and drying agent



Only detergent and drying agent intended for industrial dishwashing machines must be used. NOTE! Washing-up liquid must not be used in the machine or for pre-treating items (soaking, pre-washing, etc.). Contact your detergent supplier regarding the choice of a suitable detergent.



Be aware of the risk of handling washing and drying agents. Protective gloves and safety glasses should be used when handling dishwasher detergent. Read the warning text on the detergent and drying agent containers as well as the detergent supplier's regulations.

2.5 Operation

2.5.1 Crushing risk



The reciprocating action of the feeding cradle might cause injuries at the in- and outfeed ends of the machine and also in the scullery equipment such as corner feeding, moving straight parts and conveyor bends connected to the machine.

2.5.2 Risk of slipping



Keep the floor dry to eliminate any risk of slipping. Mop up any water which has been spilled.

2.6 Cleaning



The temperature of the water in the tank is approx. 60 °C and contains detergent. Be careful when draining and cleaning the tank. Use protective gloves.

2.6.1 Pressure washing



The machine must not be cleaned with a pressure washer. If pressurised water is directed at the electrical cabinet, the water may penetrate the cabinet and damage the electrical equipment, which may affect the safety of the machine.

In order to satisfy current requirements, electrical components of approved enclosure classes are used. There is no enclosure class capable of withstanding high pressure.

2.6.2 The outside of the machine



Pressure washers and hoses must not be used to wash the outside of the machine. Water can penetrate into the electrical cabinet and the control panel and damage the equipment, which may affect the safety of the machine.

Safety instructions

2.6.3 Cleaning the floor



When the floor is being cleaned using a pressure washer, water can splash up under the machine and damage the components. These have not been designed to withstand being washed with water. Never use a pressure washer to clean the floor within 1 metre of the dishwasher without the special protective covers that are available to prevent splashing. Problems with splashing can also occur when using ordinary hoses.

2.7 Repairing and servicing the dishwasher



Disconnect the power supply before removing the front panel. Avoid touching hot pipes and the booster heater.

2.7.1 Safety instructions if the machine is not functioning



Check the following:

- Does the display show any error messages?
- Has the machine been used according to the instructions?
- Are all the removable parts in the correct place?
- Is the mains switch in the ON position?
- Are the fuses in the electrical cabinet undamaged? Ask the service personnel to check the fuses.

If this does not solve the problem, ask authorised service personnel to check the machine.

2.8 Recycling the machine



When the dishwasher has reached the end of its service life, it must be recycled in accordance with current regulations. Contact professionals who specialise in recycling.

3. Installation

3.1 General information



The machine must be installed by authorised personnel only.

Read these instructions carefully, as they contain important information regarding the correct installation method.

The instructions should be used together with the machine's wiring diagram and flow diagrams for water and steam.



The machine is CE marked. The CE mark is only valid for machines that have not been modified. If the machine is damaged as a result of the instructions not being followed, this invalidates the supplier's guarantee and the product liability.

3.2 Requirements for the installation site

3.2.1 Lighting

In order to ensure the best possible working conditions during installation, operation, servicing and maintenance, make sure that the machine is installed in a well-lit room.

3.2.2 Ventilation

The machine produces heat and steam when in operation. In order to ensure the best possible working conditions, a certain air change rate is required in the dish-washing room. The ventilation requirements for the room are dimensioned as per applicable standards.

3.2.3 Drains

There must be a floor drain for the machine's waste water and for water used for cleaning. The drain should be located under the machine's loading bench. The floor drain capacity can be found in the TECHNICAL SPECIFICATIONS.

3.2.4 Space for servicing

A 1-metre area should be left clear in front of the machine for servicing purposes. The area above the machine must not contain any equipment which could prevent the fitting, servicing and replacement of parts.

3.3 Transport and storage

Always transport the machine in an upright position.



Take care during transport, as there is a risk of the equipment tipping over.

NOTE: The machine must not be transported without a pallet or other support. Some form of support beam must always be used along the sides of the machine during transport. otherwise the machine may become damaged. When transporting the machine without a normal wooden pallet, always check that none of the components underneath the machine can be damaged.

If the machine is not being installed immediately, it must be stored in a frost-free area where the air is dry.

3.4 Unpacking

Check against the delivery note that all the units have been delivered.

Remove the packing material. Inspect the machine for any transport damage.

3.5 Recycling the packaging



Packaging must be disposed of or recycled in accordance with local regulations.

Installation

3.6 Installation

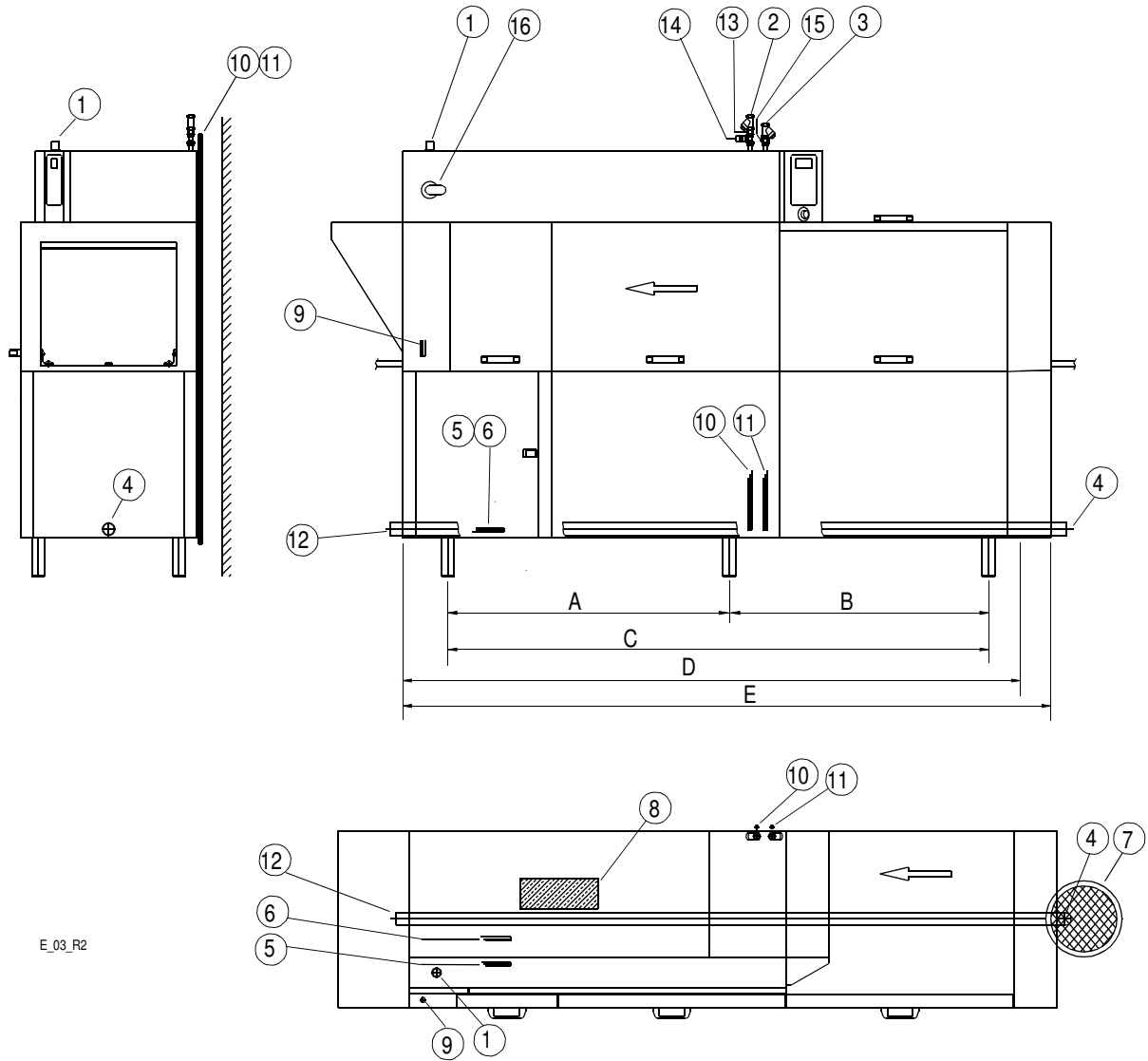

E_03_R2

Installation

1. Electrical connection
2. Cold water connection/filter
3. Hot water connection/filter
4. Drain connection
5. Steam connection
6. Condensation connection
7. Floor drain
8. Condensing battery exhaust fan
9. Alternative electrical connection
10. Alternative cold water connection
11. Alternative hot water connection
12. Alternative drain connection
13. Non-return valve
14. Vacuum valve
15. Detergent dosage outlet
16. Main switch

| | WD-151E | WD-211E | WD-241E | WD-331E | WD-421E |
|-----|---------|---------|---------|---------|---------|
| A | | | | 1360 | 2260 |
| B | | | | 1670 | 1670 |
| C | 1230 | 1830 | 2130 | 3030 | 3930 |
| D | 1535 | 2135 | 2435 | 3335 | 4235 |
| E * | 1655 | 2255 | 2555 | 3455 | 4355 |

* = Installation dimensions at bench height



Check that the overheating protection on the booster heater and the tank element are set to zero.

Installation

3.6.1 Positioning the machine

Remove the protective plastic on the sides which will be put against the wall.

Put the machine in position and check that it is horizontal using a spirit level. Adjust the height using the machine's legs.

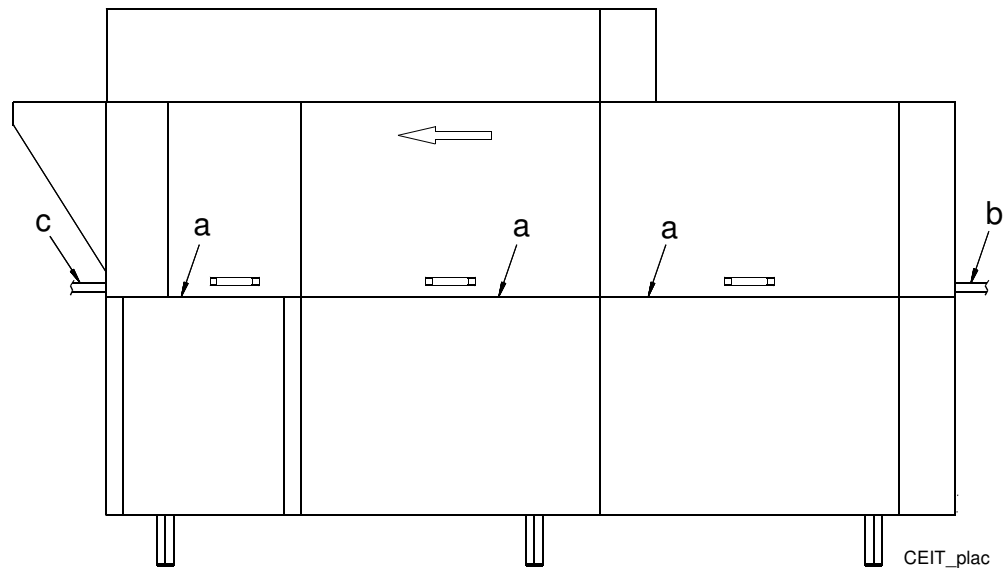

The machine must be evenly balanced and checked on three sides:

- On the cover edge of the front (a) (tank body).
- On the cover edge of the infeed (b).
- On the cover edge of the outfeed (c).

Once the machine has been filled with water, check that it is level. Close the doors and check that the tops of the doors are in a straight line. Adjust the machine using the legs.

Installation

3.7 Connections

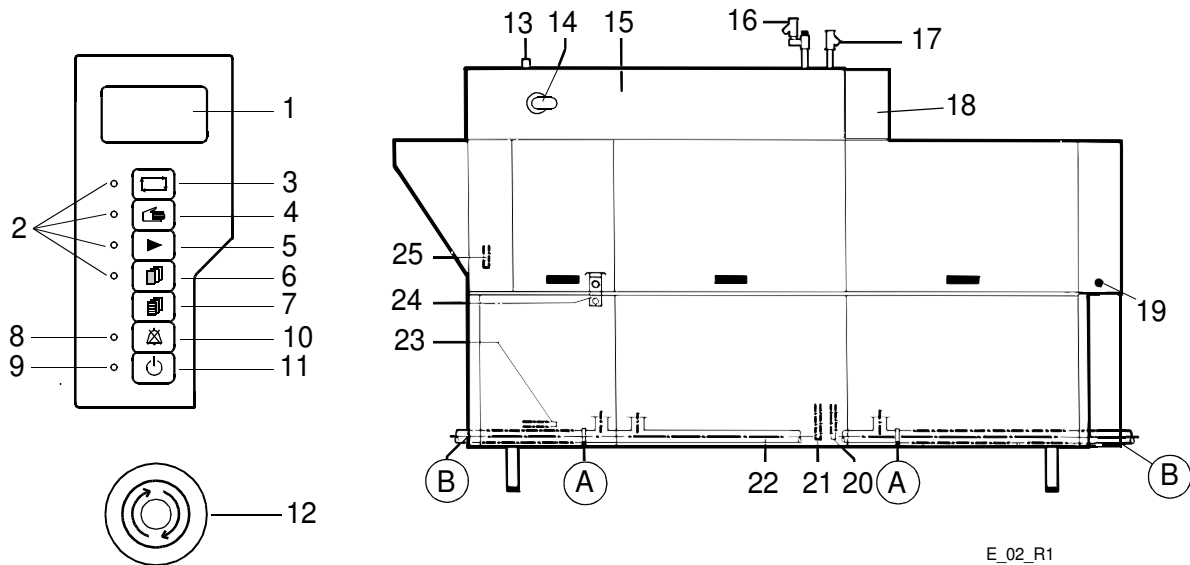

E_02_R1

Installation of the machine (the picture shows the WD-241E)

A=Drain connection

B=Hole in the end plate for the waste pipe

1. Display
2. LEDs which indicate that functions are enabled
3. Button for automatic operation
4. Button for manual operation
5. Button to the feed
6. Button for the diagnostics function.
7. Button for diagnostic messages
8. LED for indication of alarms
9. LED which lights when the power is switched on
10. Button for resetting alarm
11. On/Off
12. Emergency stop
13. Electrical connection
14. Main switch
15. Electrical cabinet
16. Cold water connection 5-12°C
17. Hot water connection 55-70°C
18. Solenoid valve box
19. Photocell for wash start
20. Alternative hot water connection (option)
21. Alternative cold water connection (option)
22. Drain connection, diameter 50mm.
23. Steam connection (option) Condensation connection (option)
24. Impulse arm for final rinse
25. Alternative electrical connection from floor

Installation

3.7.1 Electrical connection



This symbol on a component is a warning of electrical equipment. The part may only be removed by a qualified electrician or trained personnel.

Information about electrical connections can be found on the machine's wiring diagrams. The wiring diagrams are shown on the inside of the electrical cabinet door. Store the diagrams in the electrical cabinet after installation.

The machine has a built-in main switch (14). Connect the electric cable at (13). NOTE: In special cases certain dishwashers may have an electrical connection from the floor. The cable is then drawn behind the cover plate at (25).

Check the direction of rotation of the pump motors during operation when the tanks are full of water. The direction of rotation must conform without exception to the direction of the arrow on the pump. Stop the dishwasher immediately if the direction of rotation is incorrect and change two of the incoming phases.

An earth cable for potential equalisation is connected to the earth bolt on the stand. The connection is located on the beam by the final rinse zone and fitted with the following rating plate:

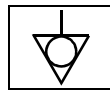

Rating plate for earth bolt

After completing the electrical installation, switch on the main switch and all circuit breakers.

3.7.2 Water connection

Connect the cold and hot water pipes according to the labels by the connection points (20,21). If the machine is connected to a hose, the internal diameter of the hose must be at least 12 mm.

The hot water connection is fitted with a filter. The cold water connection is fitted with a filter, non-return valve and vacuum valve. The connections have an internal thread.



A stopcock must be installed on the water supply pipes.

It is important that the water supply has sufficient pressure to ensure the correct flow of water to the machine. The required pressure can be found in the TECHNICAL SPECIFICATIONS. If the water pressure is too low, a booster pump must be fitted.

3.7.3 Steam connection (option)

If the machine is steam-heated, connect the pipes for steam and condensation water at (23).

Installation

3.7.4 Drain connection

The drain connection must consist of a 50 mm metal pipe that will withstand mechanical impact or a 50 mm plastic pipe. The floor drain capacity can be found in TECHNICAL SPECIFICATIONS.

The drain (22) can be fitted to the left or right. The drain is connected at (A) and run to the floor drain where it should flow freely above the water level.

Remove the perforated section of the end plate at (B) and pull the pipe through the hole.

3.7.5 Ventilation

The machine has a condensing battery connected to an exhaust fan to reduce the amount of steam released. Extractor fans for extracting steam can be installed above the infeed and outfeed openings, as well as above the area of the machine where steam is emitted from the condensing fan.

If a hood is fitted over the machine, it must cover both the infeed and the outfeed. The front of the hood must be positioned at least 500 mm in front of the machine to allow access for service and repairs.

3.7.6 Installing extra equipment

Limit switch

The limit switch is installed on the lower terminal block, which is placed in front of the chemical wash tank. When connecting, remove the existing clamp on the connection points. See the machine's wiring diagram. NOTE: The machine's voltage is 24V.

Conveyors

Installation of in- and outfeed equipment (conveyors, curves) is performed in accordance with the wiring diagram's main circuit instructions. This applies to machines equipped with a motor switch and contactors for this equipment.

Connection of supply voltage to the in- and outfeed equipment is performed in accordance with the wiring diagram's instructions. NOTE: The machine's voltage is 24V.



When fitting a motor switch and contactors, use the components on the wiring diagram and follow the connection instructions. This affects the manufacturer's liability - see "SAFETY INSTRUCTIONS."

Emergency stop

An additional emergency stop can be connected at the lower terminal block, which is placed in front of the chemical wash tank. Replace the existing clamp on the connection points with the connection for a new emergency stop. See the machine's wiring diagram. NOTE: The machine's voltage is 24V.

Installation

3.7.7 Setting the flows

| WD-151E | Flows, no 117078- | Cold water final rinse, no 117078- |
|---------------------------------------|----------------------|---------------------------------------|
| Y02 final rinse | 7,0 ± 0,2 l/min | 1,8 l/min |
| Overflow final rinse to chemical tank | 2 l/min | |
| Recirculating rinse | 5,0 + 0-0,3 l/min | |
| From M02 to the drain / PRM | 5,0 + 0-0,3 l/min | |
| Y05 cooling condensing battery | 3,7 ± 0,2 l/min | |

| WD-211E | Flows, no 117078- | Cold water final rinse, no 117078- |
|---------------------------------------|----------------------|---------------------------------------|
| Y02 final rinse | 7,0 ± 0,2 l/min | 1,8 l/min |
| Overflow final rinse to chemical tank | 2 l/min | |
| Recirculating rinse | 5,0 + 0-0,3 l/min | |
| From M02 to the drain / PRM | 5,0 + 0-0,3 l/min | |
| Y05 cooling condensing battery | 3,7 ± 0,2 l/min | |

| WD-241E | Flows, no 117078- | Cold water final rinse, no 117078- |
|---|----------------------|---------------------------------------|
| Y02 final rinse | 7,0 ± 0,2 l/min | 1,8 l/min |
| Overflow final rinse to chemical tank | 2 l/min | |
| Recirculating rinse | 4,4 + 0-0,3 l/min | |
| From M02 to tank 1 / PRM | 5,0 + 0-0,3 l/min | |
| Y05 cooling condensing battery + tank 1 | 3,7 ± 0,2 l/min | |

| WD-331E | Flows, no 117078- | Cold water final rinse, no 117078- |
|---|----------------------|---------------------------------------|
| Y02 final rinse | 7,0 ± 0,2 l/min | 1,8 l/min |
| Overflow final rinse to chemical tank | 2 l/min | |
| Recirculating rinse | 4,4 + 0-0,3 l/min | |
| From M02 to tank 1 / PRM | 5,0 + 0-0,3 l/min | |
| Y05 cooling condensing battery + tank 1 | 3,7 ± 0,2 l/min | |

| WD-421E | Flows, no 117078- | Cold water final rinse, no 117078- |
|---|----------------------|---------------------------------------|
| Y02 final rinse | 7,0 ± 0,2 l/min | 1,8 l/min |
| Overflow final rinse to chemical tank | 2 l/min | |
| Recirculating rinse | 4,4 + 0-0,3 l/min | |
| From M02 to tank 1 / PRM | 5,0 + 0-0,3 l/min | |
| Y05 cooling condensing battery + tank 1 | 3,7 ± 0,2 l/min | |

Final rinse

The final rinse flow is adjusted using the reducing valve which is in the solenoid box (18).

The machine feed must be running.

Activate the photocell (19) at the infeed end and the impulse arm (24) for the final rinse behind the final rinse door. Close the doors. Feed a number of baskets through the machine.

Press button (6). The display shows: SETPOINTS, DIAGNOSIS, RELAY TEST, STATISTICS. Select DIAGNOSIS by pressing button (6).

Press button (7) and scroll down until the text "DI16 CARD1 BV02 FLOW SENSOR" appears on the display. Read off the flow in litres/minute and, if necessary, adjust it using the reducing valve.

After checking and adjusting, press and hold button (6) until the corresponding LED goes out.

Reset the photocell and the impulse arm to the initial position.

To set the final rinse temperature, see the ADJUSTMENT INSTRUCTIONS.

3.8 Installing detergent and drying agent equipment

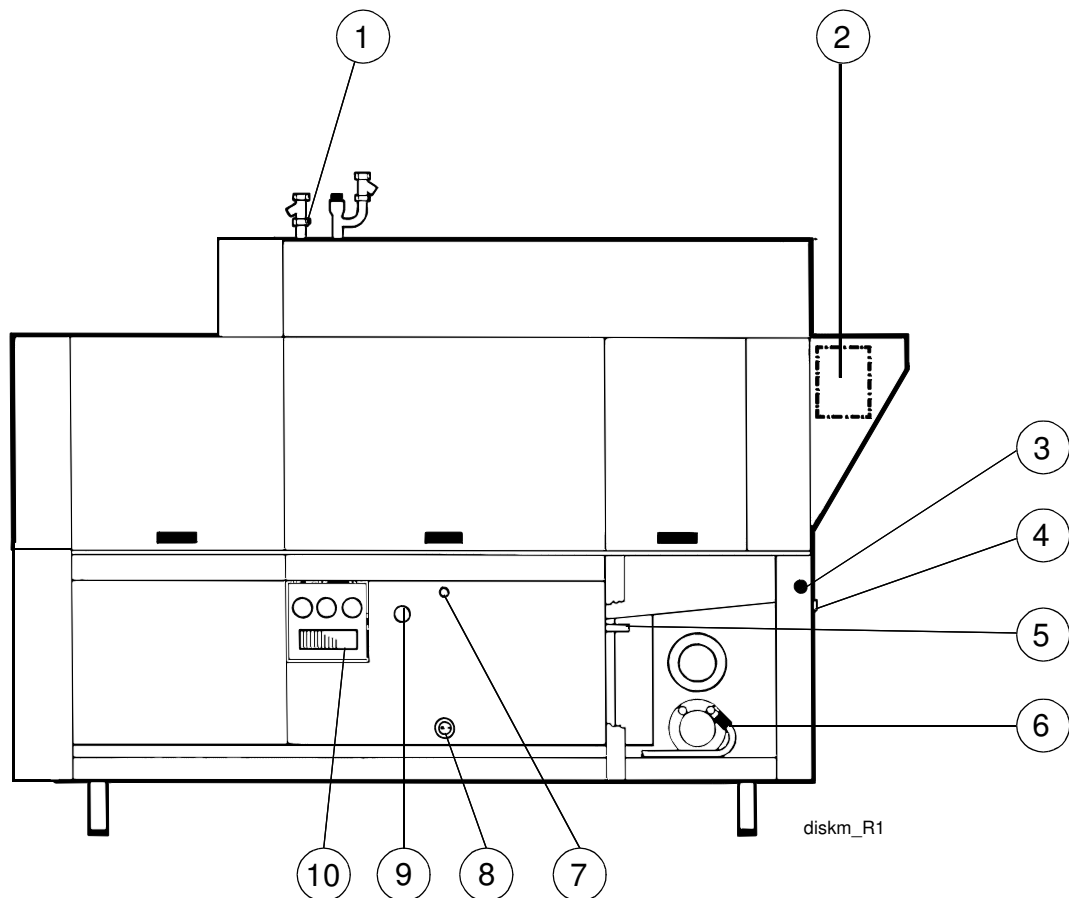

1. Hot water outlet
2. Alternative location of detergent equipment
3. Hole \varnothing 25 mm for hose intended for detergent in solid form
4. Hole \varnothing 19 mm for drying agent hose
5. Plugged connection \varnothing 18 mm for connecting hose for detergent in solid form
6. Drying agent dosage outlet
7. Plugged connection \varnothing 11 mm for liquid detergent
8. Plugged hole \varnothing 22mm for measuring cell. The measuring cell is connected in the terminal box (10).
9. "DETERGENT" sticker. The label is affixed to the inside rear wall of the chemical wash tank and indicates the alternative position of the detergent opening. Drill a hole from the back of the chemical tank through the plugged hole in the cover plate.
10. Terminal box with connections for detergent and drying agent.

Installation

3.8.1 Electrical connection of the equipment

The machine comes ready for fitting detergent and drying agent equipment, but this is not included with the machine.

To avoid making unnecessary holes in the machine, the equipment should be placed on the wall behind the machine on the outfeed side.

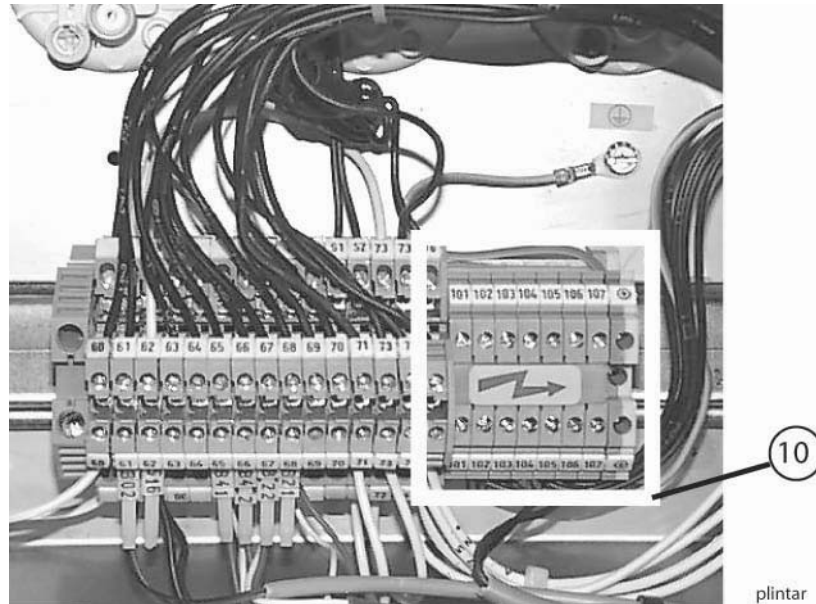

Connections for detergent and drying agent. NOTE: 230V

Installation

3.8.2 Detergent dosing system

The water outlet (1) for the detergent dosage is placed on the incoming hot water pipe.

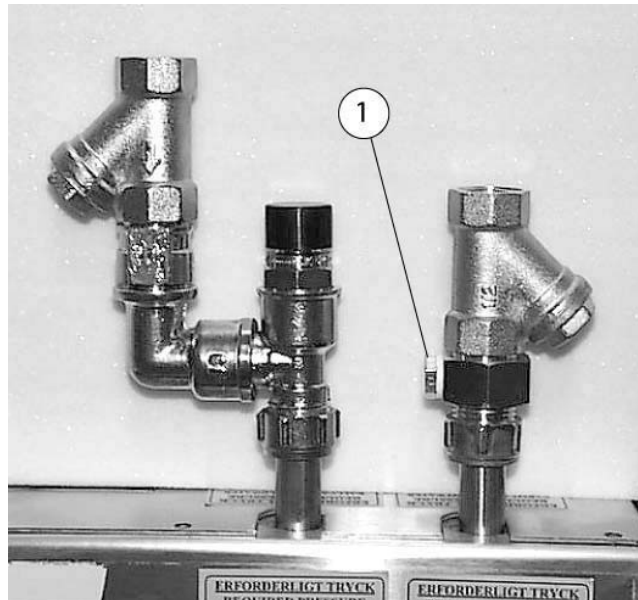

varmvatten

Hot water outlet

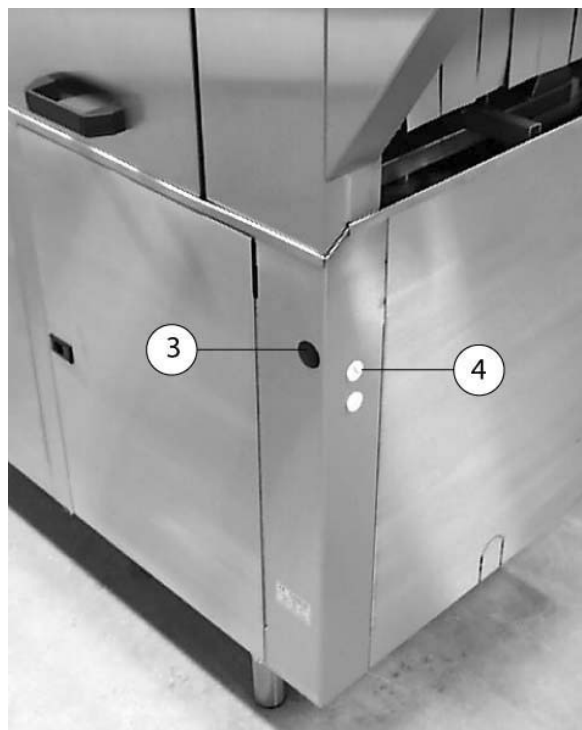

proppade

Plugged holes for hoses for detergent and drying agent.

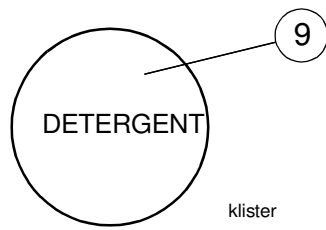

Adhesive label indicating alternative opening for detergent.

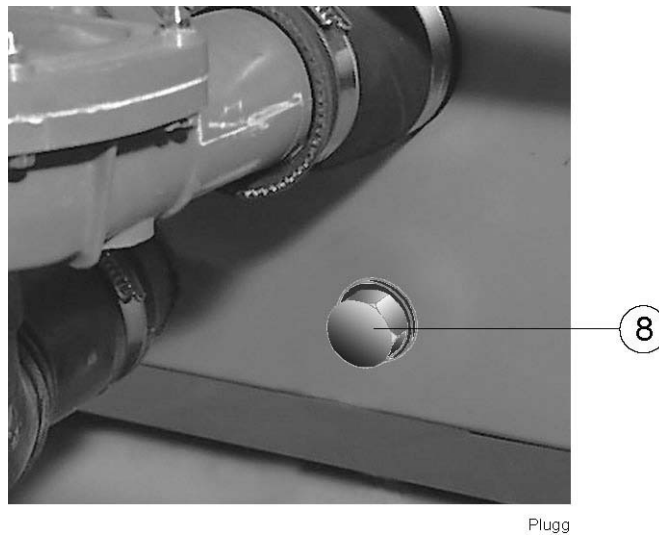

Plugged hole for measuring cell.

3.8.3 Drying agent dosing system

The connection for drying agent (6) is located next to the booster heaters.

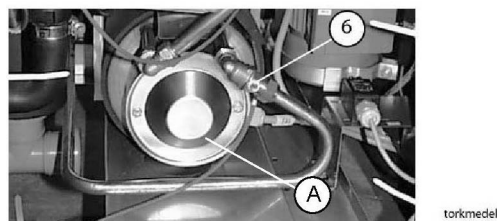

*Drying agent dosage outlet
A=Lower booster heater*

Installation

3.9 Trial run

Prepare the machine for a trial run by following the INSTRUCTIONS FOR USE. The instructions describe the measures that must be taken to prepare the machine for operation.

3.9.1 Start-up schedule

This should be completed and signed by the customer on start-up.

Machine type:

Machine serial number:

Installation date:

| |
|------------------|
| Customer: |
| Postal address: |
| Telephone: |
| Contact: |

| |
|----------------|
| Dealer: |
| Telephone: |
| Contact: |

| |
|------------------------------|
| Installation company: |
| Telephone: |
| Contact: |

| |
|-------------------------|
| Service company: |
| Telephone: |

| |
|----------------------------|
| Detergent supplier: |
| Telephone: |

| |
|------------------------------|
| End user's signature: |
| |

| |
|--------------------------------|
| Name in block capitals: |
| |

Read the installation and user manuals carefully. Then check the following points:

Installation

1. Check:

- Water, steam and drain connections
- That the machine is evenly balanced
- That the closed doors are in line
- That the benches, conveyor bend etc. are correctly fitted
- Detergent and drying agent
- Filters, level pipe, tank filter and curtains are in position
- The mini-switches for all the heating elements must be in the OFF position
- That the overheating protection on the booster heater and the tank element are set to zero

2. Filling the machine:

- Close the doors
- Switch on the main switch and press button (11)
- Start the filling process by pressing button (3) or (4)
- Fill the machine with water as per the INSTRUCTIONS FOR USE Note: It takes approximately 10 minutes to fill the system. In machines with ELECTRONIC, the booster heaters fill automatically when the doors are closed. The machine has a filling check function for the booster heaters. When the function is activated, a check is carried out to ensure that the booster heaters are full of water, before the element is switched on. Note: If the filling process is interrupted using the main switch, the check starts again from the beginning.
- When the filling check has been completed and all the tanks are full, the mini-switches for the booster heaters switch on.

3. Check the setting of the reference values:

- All the reference values are set to the recommended values on delivery.

4. Start the machine:

- Check the direction of rotation of the pumps NOTE: If the direction of rotation is wrong, the phase must be inverted on the incoming feed.
- Check that the overload switch on the feed cradle is functioning.

5. Lock the impulse arm and the photocell in the activated position:

- Run the machine continuously for 10 minutes. Check and adjust the temperature and water flow
- Final rinse (according to the table in the manual)
- Intermediate rinse (according to the table in the manual)
- Pre-rinse (according to the table in the manual)

6. Run a number of washes complete with loads and check that:

- The basket is in the correct position after the photocell
- There are no water leaks
- The door breaker works
- The limit switch is working
- Steam discharge from the machine
- The water temperatures are maintained
- The washed items are clean
- The washed items are dried

7. Final check: Empty the machine, press button (11) and switch off the power using the main switch:

- Re-tighten all the connections on the circuit breakers and relays
- Check that all the mini-switches and the motor cut-off switch are in the ON position.
- Display the maintenance instructions supplied with the machine.

8. Train the dishwashing staff

3.10 Technical documentation



To ensure that the machine is used correctly, it is essential that the documentation supplied with the machine is made available to the staff who will be using the machine. The installation and user manuals should be kept near the machine.

If the service manual is supplied with the machine, it should be given to the service engineer who is responsible for the machine.

If the spare parts manual is supplied with the machine, it should be given to the service engineer who is responsible for the machine.

If the WEB Tool manual is supplied with the machine, it must be kept near the machine.

Instructions for use

4. Instructions for use



All staff using the machine must be given training in how the machine works by the person responsible for staff safety.

The dishwasher should not be used by anyone suffering from a physical or mental illness.

Children should be supervised to ensure that they do not play with the machine.



Text messages appear on the machine's display which indicate what the machine is doing. The machine's reference values, which can be changed, and alarms of different types also appear on the display.

The machine is intended for washing items used to prepare and serve food, including various types of items for storing food. You should therefore use a detergent suitable for this type of washing.

4.1 Preparations

4.1.1 The machine's design

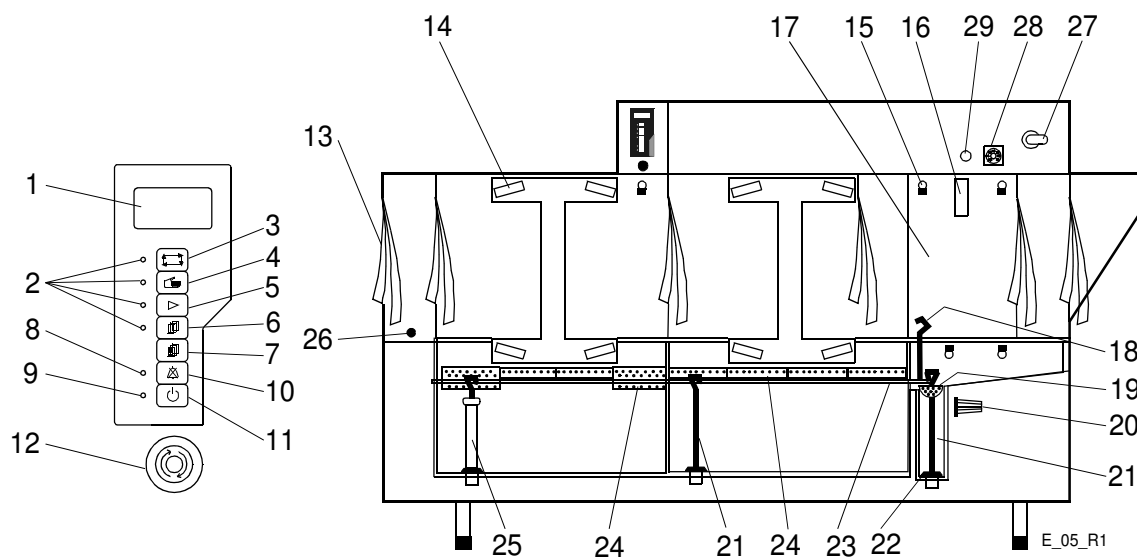

Instructions for use

1. Display
2. LEDs which indicate that functions are enabled
3. Button for automatic operation
4. Button for manual operation
5. Button to the feed
6. Button for the diagnostics function.
7. Button for diagnostic messages
8. LED for indication of alarms. If the LED flashes, the alarm can be reset by pressing button (10).
9. LED which lights when the power is switched on
10. Button for resetting alarm
11. On/Off
12. Emergency stop
13. Curtains
14. Wash arms
15. Rinse nozzle
16. Catch
17. Door
18. Lever for emptying the tanks
19. Filter for the final rinse
20. Filter
21. Outlet seal
22. Rubber sleeve
23. Lifting arm for level pipe and outlet seals
24. Filters
25. Level pipes
26. Photocell
27. Main switch
28. Timer for a timed start of the machine (option)
29. Button for activating the timer (option)

Instructions for use

4.1.2 Preparations before filling

Check:

- that the machine has been cleaned and that the stopcocks on the water supply are open
- that the main switch is switched on
- the amount of detergent and drying agent



NOTE: Washing-up liquid must not be used in the machine or for pre-treating items (soaking, pre-washing, etc.). Ordinary washing-up liquid must not be used in the machine or for soaking. It causes foam to form and produces poor washing results.

Fit:

- level pipe (25) and outlet seals (21). Hook them firmly in position on the lifting arm (23) and check that they are closed. The rubber sleeve (22) must seal against the base plate. Check that the rubber sleeve has not been damaged.
- strainers (19,24)
- curtains (13)

4.1.3 Filling and heating the machine

- Turn the main switch (27) to the ON position.
- Close the doors.
- Press button (11) to switch on the power supply.
- Start the filling process by pressing button (3) or (4). The filling and heating process will begin.
- When the machine is filled and heated, it starts and runs for a while to mix the detergent.
- When the detergent is mixed, the message on the display indicates that the feed should start. Start the feed by pressing the button (5).
- The machine is now ready to wash.



NOTE: The time it takes for the machine to fill and heat up to the right washing temperature varies between 5 and 30 minutes, and depends on the temperature of the incoming water.

Instructions for use

4.1.4 Filing and heating the machine using timer start (option)

The machine can be made ready for operation using timer start with automatic filling and heating at a set time.

- When using timer start, all removable components (level pipes, outlet seals, filters, curtains, etc.) must be in position and the doors must be closed.
- Switch on the power to the machine using the button (11). The corresponding LED lights up and the text in the display will indicate that the timer start has been activated.
- Enter the number of hours until the machine should start on the timer (28).
- Press the button (29) to start the timer.
- When the machine starts, the sequence of events appears on the control panel display. After filling and heating, the machine will start and run for a while to mix the detergent.
- Once the detergent is mixed, the display will indicate that feeding should start. Press the button (5) to start the conveyor belt.
- The machine is now ready to wash.

Timer functions

The timer scale can be adjusted, if required, to change the time range and time units that are displayed.

To adjust the scale, use a screwdriver on the two adjuster screws (A) and (C).

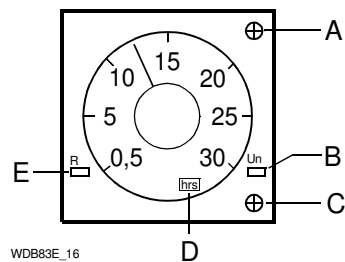

The timer functions

A=Adjuster screw for changing the time range of the scale. The screw has two positions. By turning it the scale can be adjusted to the time ranges of 0.2-12 and 0.5-30. Use the adjuster screw (C) to set the time unit to hours.

B=LED which flashes when the timer is activated and the countdown of the set time is in progress..

C=Adjuster screw for changing the time unit. Turn the screw with a screwdriver to change the setting of the timer scale to seconds, minutes or hours. The time unit is shown in the window (D).

D=Time unit display. The time units, which can be selected using the adjuster screw (C), are shown in the table below.

E=LED which indicates that the time countdown has finished.

The timer scale should preferably be set to hours if the timer start is to be used (time units "hrs" and "10 hrs" in the table). The table shows all the possible settings which can be displayed in the window (D), with examples of how you set the number of hours until the machine starts.

Instructions for use

| Setting the time unit | |
|---------------------------------------|--|
| The time unit shown in the window (D) | Example of settings |
| 0.1 s (seconds x 0.1)) | --- |
| sec (seconds) | --- |
| 10 s (seconds x 10) | --- |
| min (minutes) | --- |
| 10 m (minutes x 10) | --- |
| hrs (hours) | If the machine is to start in 10 hours time, set the timer dial to 10. The window (D) should display the time unit "hrs" which can be set using the screw (C). |
| 10 h (hours x 10) | If the machine is to start in 50 hours time, set the timer dial to 5. The window (D) should display the time unit "10 hrs" which can be set using the screw (C). |

4.2 Using the machine



DIN 10510 is a German standard which describes how the washing process must work in rack conveyor or flight type machines in order to ensure good washing results. Amongst other things, it recommends that the contact time should be around 120 seconds for normally soiled loads. The contact time is the time which the load spends in a wash or rinse zone with washing water containing detergent. In principle this means the period from when the load enters the pre-wash zone to when it is rinsed with clean water in the final rinse zone. The standard is a useful means of comparing the capacity and consumption of different dishwashers.

4.2.1 Washing

Feeding loads into the machine

- Before feeding dishware into the machine, soak dried-on food and remove large food particles. The items must not be soaked or pre-washed with ordinary washing-up liquid.
- Put the items in baskets. Plates and trays should be placed lengthways in the dishwasher. Canteens and large items should always be upended in special racks.
- Push the basket carefully towards the feed opening until the feed device hooks the basket in place.



Once the feed device begins to pull the basket into the machine, the basket must not be pushed manually. This may disturb the wash cycle, resulting in impaired wash results.

Leave the following gaps between the baskets when you feed them in:

- WD-151E=approx 50 cm.
- WD-211E=approx 30 cm.
- WD-241E=approx 25 cm.
- WD-331E=Hardly any gap (the baskets should be close together).
- WD-421E=Hardly any gap (the baskets should be close together).

Increase the distance if the items to be washed are heavily soiled.

Washing with automatic operation

For automatic operation, press button (3). The corresponding LED (2) lights up.



Button for automatic operation

Washing with automatic stop. The machine starts when a basket is pushed into it. The basket stays in the washing zone until the next basket pushes it onwards. The machine stops automatically after a set period of time if no new basket is fed in.

Start the feed by pressing the button (5).

Washing with manual operation

For manual operation, press button (4). The corresponding LED (2) lights up.



Button for manual operation

Washing without automatic stop. The machine starts straight away. Manual operation is a good idea when the items are heavily soiled. If you only feed in one basket, it stops and stays in the washing zone. The time in the zone is decided by the operator. The basket is pushed out of the machine when a new basket is fed in.

Start the feed by pressing the button (5).

4.2.2 Guaranteed final rinse

The temperature of the final rinse water is always correct and the right amount of rinse water is always used.

If the rinse temperature is too low, an alarm is triggered on the control panel. The machine continues washing until the right temperature is reached. However, the alarm can be reset in the meantime by pressing button (10) on the panel. The wash programme continues, but the machine will then rinse at a lower temperature. However, an alarm is displayed.

If the flow during the final rinse is too low, an alarm is displayed on the control panel. The alarm can also be set up to stop the machine. The factory setting is for an alarm only. If you need an alarm which stops the machine, the setting must be changed by a service engineer in the machine's software.

Instructions for use

4.2.3 Emergency stop

The machine has an emergency stop button (12). If the machine has been stopped during operation using the emergency stop button, the button must be re-set by turning it in the direction of the arrows. Then press the button (5) to restart the feed.

4.2.4 Changing the water

NOTE: The water in the wash tank must be changed regularly, otherwise foam will start to form and the washing results will deteriorate. If the filters are clogged with foam or if foam comes out of the waste pipe, the water must be changed immediately.

For best wash results, it is important that the water in the tanks is changed when it becomes too dirty. The water should always be changed if foam begins to form in the washing tanks.

- Switch the machine off by pressing button (11).
- Remove the filters (24) and drain the tanks by pulling the lever (18).
- When the tanks have been drained, close the level pipes and the outlet seals using the lever (18).
- Replace the filters.
- Refill the machine. See "Filling and heating the machine".

4.3 After use – cleaning



HACCP is a preventive inspection system which ensures that hygiene requirements are met during the washing process and the cleaning of the machine. As a result of its design, the machine meets strict hygiene requirements. Regular, thorough cleaning is also important from a hygiene perspective. Cleaning the machine carefully helps to ensure good washing results and reduces the risk of dirt accumulating inside the machine.

See the WEB Tool manual for the HACCP alarm options.

Instructions for use

4.3.1 Daily cleaning

Cleaning the inside of the machine

- Unhook the curtains (13) at the infeed end and wash them in a basket.
- Switch the machine off by pressing button (11).
- Empty the tanks by pulling the lever (18).
- Clean the filters (24), all the curtains (13), the level pipe (25), the outlet seals (21) and the rinse nozzles (15). Never leave the level pipes and outlet seals so that the rubber sleeve rests on a surface. The sleeve can become deformed leading to the risk of water leakage in the tanks.
- Clean the washer arm nozzles (14).
- Clean the doors (17). Wipe the rubber strips on the doors which are fitted at the top of the back of the doors.
- Rinse all the inside surfaces of the machine and clean the tanks.
- Finally, clean the strainer (19).
- Empty the final rinse tank and clean the filter (20). The filter is placed behind the lower door at the outfeed end. Unscrew the cover (A) and remove the filter (B). Clean the filter. Make sure that the cover seal provides a good seal when refitting.
- Refit the components.
- Leave the doors open.

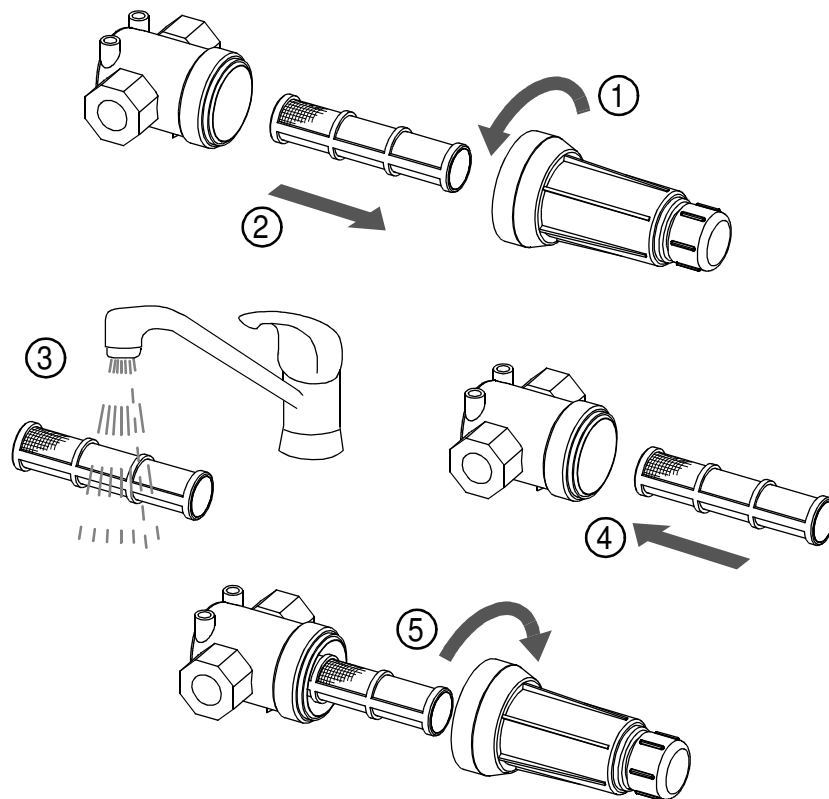

Rec_filter

Filter for final rinse

Instructions for use

Cleaning the outside of the machine

Wipe the outside of the machine with a soft, damp cloth.



If detergent is used, it must not contain abrasives. Detergents containing abrasives will damage the stainless steel panels.



The outside of the machine must not be hosed down. Water can enter the machine and damage the control panel and electrical equipment.

Incorrect cleaning methods

NOTE: If the incorrect cleaning method is used, this may damage the machine. The following points must be observed:



Do NOT use steel wool as it will cause corrosion to form in the machine.



Pressure washers can damage the machine and must NOT be used for cleaning purposes. Never use a pressure washer to clean the floor within 1 metre of the dishwasher without the special protective covers that are available to prevent splashing. The supplier cannot be held liable for any faults caused by the use of pressure washers on the machine and any such use will invalidate the warranty.

There is a risk of splashing even if the floor is hosed down.

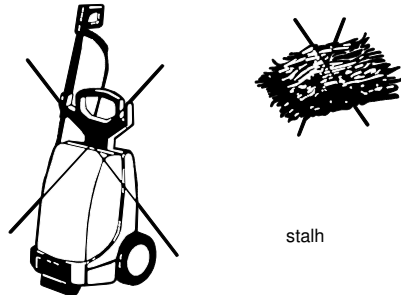

Steel wool and pressure washers must not be used for cleaning.

4.3.2 Cleaning and checking each week or as required

Weekly cleaning should be more thorough than daily cleaning. In addition to the daily cleaning measures, follow these instructions:

- Clean the washer arms (14). Brush and rinse the inside of the washer arms and clean the nozzles.
- Check and clean the rinse nozzles (15).
- Remove and clean the doors (17). Open the door, depress the catch (16) and lift the door vertically.
- Refit all cleaned components.
- Decalcify the machine when necessary.

Instructions for use

4.3.3 Cleaning in the event of an alarm or once a year

The machine's condensing battery (D) must be cleaned at least once a year or when an alarm with a message about cleaning the battery appears on the control panel display.

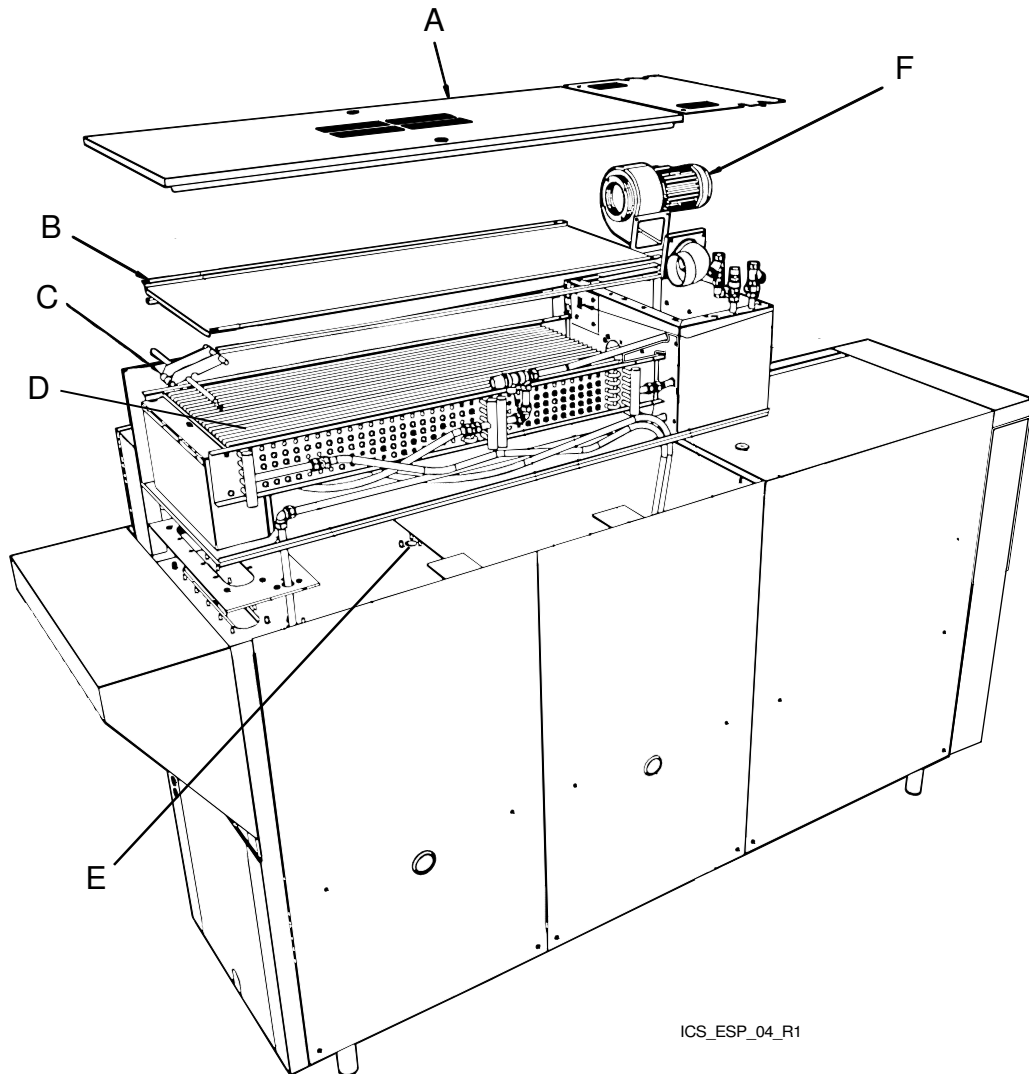

ICS_ESP_04_R1

A=Top panel
B=Cover plate
C=Lifting arm
D=Condensing battery
E=Drain F=Fan motor

Instructions for use



NOTE: When cleaning the battery and the base of the battery box, do not use more water than the drain (E) under the battery can remove from the machine. The battery must be cleaned with hot water at normal pressure. Do not aim the water directly at the fan motor (5) on the end of the battery. The electric motor may be damaged if it is rinsed with high-pressure water.

- Remove the top panel (A) on the condensing battery box.
- Remove the cover plate (B) from the condensing battery by unscrewing the wing nuts which fasten it in place. Lift up the condensing battery using the lifting arm (C) to make it easier to remove.
- Check from inside the machine that the drain (E) under the battery is not blocked.
- With the condensing battery removed, begin by cleaning the bottom plate of the battery box. Then check that the drain (E) is not blocked.
- Next clean the condensing battery (D). Rinse between the cooling fins from above. If the condensing battery is very dirty, a cleaning product with a neutral ph which will dissolve grease can be used. Check the drain.
- Finish by washing the base of the battery box again.
- Replace the condensing battery using the lifting arm (C), attach the cover plate securely (B) using the wing nuts, before fitting the top panel (A).

Instructions for use

4.3.4 Operating problems

Troubleshooting

In addition to the faults shown on the control panel, other faults can occur. The table below shows some faults which can be rectified by the operator. If the problem persists, contact authorised service personnel.

| Problem | Cause | Action |
|---|---|---|
| No indication on the control panel display when the power is switched on by pressing button (11). | The mains switch is off. | Turn on the mains switch. This is located on the door of the machine's electrical cabinet. |
| The machine does not fill with water. | The stopcock on the incoming water supply is closed. | Open the stopcock. |
| | The doors are open. | Close the doors. |
| The machine does not stop filling. | Level pipe or outlet seal not in place. | Fit the level pipe or outlet seal. |
| | The level pipe or one of outlet seals' rubber sleeves are not sealing against the bottom plate. | Check that the level pipe and drain seals are closed. Replace the rubber sleeves, if they are damaged. |
| The machine does not start washing. | The doors are not closed. | Close the doors. |
| | Outward feed conveyor limit switch has been activated. | Remove the basket from the limit switch. |
| The display indicates that one door is open. | An object is preventing the door from closing. | Remove the object. |
| Noise from the wash pump. | Low water level in the tank. | Check that the tank's level pipe or outlet seal are closed. Change the rubber sleeve if it is damaged. |
| | Foam in the tank. | Change the water. |
| The machine is not cleaning properly. | The rinsing and washing nozzles are clogged with dirt. | Check and clean the nozzles. |
| | There is too little detergent. | Check the amount of detergent. |
| | Foam formation in the washing tanks. | Check that the washing temperature is not too low and that the correct detergent is being used. Change the water if foam forms. |
| | Dirt has dried on the items to be washed. | Soak the items before washing. |
| | The water in the tanks is too dirty. | Change the water. |
| | The items are incorrectly positioned in the baskets. | Use the right type of basket for the items and put the items in the basket following the instructions in the section "Using the machine". |
| The items are tipped over in the baskets. | Curtains fitted incorrectly. | Fit the curtains correctly. |
| | Items positioned incorrectly in the baskets. | Put the items in the correct position. |
| | The items are too light. | Use a mesh grid to hold the items in place. |
| The washed items do not dry. | The rinsing nozzles are blocked. | Check and clean the nozzles. |
| | Too little drying agent. | Check the quantity of drying agent. |

When you contact service personnel, you will need to provide the following information:

- Machine model
- Machine serial number and installation date
- A brief description of the problem
- What happened immediately before the fault occurred

Instructions for use

Machine faults and user errors

Machine faults and user faults are indicated by messages on the display (1). The alarms indicated with a flashing LED (8) can be reset by pressing button (10) when the cause of the alarm has been rectified. Alarms that are indicated by the fact that LED (8) is lit but not flashing cannot be reset by the operator.

The following alarms can be dealt with by the operator. For other alarms, or if an alarm reset with button (10) recurs, authorised service personnel must be contacted.

| Alarm text | Cause | Action |
|---|---|---|
| (63) POWER SUPPLY FAILURE CHECK THE EMERGENCY SWITCH | The emergency stop button (12) is depressed. | Reset the emergency stop by turning it in the direction of the arrows. Restart the machine. |
| (1) EMERGENCY STOP ACTIVATED | The emergency stop button (12) is depressed. | Reset the emergency stop by turning it in the direction of the arrows. Start the feed by pressing button (5). |
| (100) NOMINAL VALUES RESTORED FROM UI | Internal memory corrupt. | Reset the alarm by pressing button (10). Contact service personnel. |
| (14) WEAK SIGNAL FROM PHOTOCELL START WASH CLEAN PHOTOCELL | Dirt on the photocell (26) inside the infeed hood. | Clean the photocell. The alarm in the display will disappear after cleaning. |
| (47) HACCP ALARM PUMP FUNCTIONALITY DEFECT PRESS RESET | One of the pumps is not working. | Reset the alarm using button (10). Contact service personnel. |
| (64) HACCP ALARM WRONG TEMPERAURE IN TANK PRESS RESET | The washing temperature in one of the tanks is too low. | Reset the alarm using button (10). Contact service personnel. |
| (67) HACCP ALARM WRONG TEMPERATURE IN BOILER PRESS RESET | The temperature in one of the booster heaters is too low. | Reset the alarm using button (10). Contact service personnel. |
| (72) HACCP ALARM WASHING DETERGENT FUNCTIONALITY DEFECT PRESS RESET | The detergent has run out. | Check and will with new detergent. Reset the alarm using button (10). |
| (78) HACCP ALARM FINAL RINSE DEFECT PRESS RESET | The water stopcock is closed. The rinse nozzles (15) for the final rinse are blocked. | Open the stopcock. Clean the nozzles. Reset the alarm using button (10). |
| (29) EXTERNAL ALARM INPUT ACTIVATED | | Reset the alarm using button (10). Contact service personnel. |
| (30) TIMEOUT FILLING OF TANKS PRESS RESET | The water stopcocks are closed. The level pipe (25) or the outlet seals (21) are not closed. The rubber sleeves are not sealing against the bottom plate. | Open the stopcocks. Close the level pipe and the outlet seals. Check the rubber sleeves. Reset the alarm using button (10). |

Instructions for use

| Alarm text | Cause | Action |
|--|---|--|
| (31) TIMEOUT HEATING TANKS AND BOILERS PRESS RESET | The heating process took too long. | Reset the alarm using button (10). Contact service personnel. |
| (32) BASKET IN FINAL RINSE ZONE OR SENSOR ERROR B02 PRESS RESET | Starting the machine with a basket in the final rinse zone. The impulse arm is activated. | Remove the basket. Reset the alarm using button (10). Contact service personnel. |
| (33) DOOR IS OPEN CLOSE DOOR | | Close the door and start the feed by pressing button (5). |
| (40) LOW LEVEL IN TANK 1 (PRE RINSE TANK) | The level pipe is not closed. The level pipe's rubber sleeve is not sealing against the bottom plate. | Close the level pipe. Check the rubber sleeve. |
| (41) LOW LEVEL IN TANK 2 (CHEM WASH TANK 1) | The level pipe or the outlet seal are not closed. The rubber sleeve does not seal against the bottom plate. | Close the level pipe or the outlet seal. Check the rubber sleeve. |
| (42) LOW LEVEL IN TANK 3 (CHEM WASH TANK 2) | The outlet seal is not closed. The outlet seal's rubber sleeve is not sealing against the bottom plate. | Close the outlet seal. Check the rubber sleeve. |
| (43) LOW LEVEL IN TANK 2/3 (CHEM WASH TANK 1/2) | The outlet seal is not closed. The outlet seal's rubber sleeve is not sealing against the bottom plate. | Close the outlet seal. Check the rubber sleeve. |
| (44) LOW LEVEL IN TANK 4 (CHEM WASH TANK 3) | The outlet seal is not closed. The outlet seal's rubber sleeve is not sealing against the bottom plate. | Close the outlet seal. Check the rubber sleeve. |
| (45) LOW LEVEL IN FINAL RINSE TANK | The outlet seal is not closed. The outlet seal's rubber sleeve is not sealing against the bottom plate. | Close the outlet seal. Check the rubber sleeve. |
| (51) OVERLOAD FEEDING ACTIVATED REMOVE OBJECT RESTART FEEDING | An object has stopped the feed. | Remove the item. Start the feed by pressing button (5). |
| (85) OVERLOAD FEEDING ACTIVATED PRESS RESET | | Reset the alarm using button (10). |
| (52) FEEDER LIMIT SWITCH ACTIVATED. REMOVE OBJECT FROM THE FEEDER LIMIT | A basket has activated the limit switch. | Remove the basket. The feed will start automatically. |
| (61) LOW TEMPERATURE IN TANK 2 (CHEM WASH TANK 1) | The temperature in tank 2 is too low. | Reset the alarm using button (10). Contact service personnel. |
| (62) LOW TEMPERATURE IN TANK 3 (CHEM WASH TANK 2) | The temperature in tank 3 is too low. | Reset the alarm using button (10). Contact service personnel. |
| (81) LOW TEMPERATURE IN TANK 4 (CHEM WASH TANK 3) | The temperature in tank 4 is too low. | Reset the alarm using button (10). Contact service personnel. |

Instructions for use

| Alarm text | Cause | Action |
|---|---|--|
| (66) LOW TEMPERATURE IN THE FINAL RINSE BOILER | The temperature in the booster heater is too low when the final rinse starts. | Reset the alarm using button (10). Contact service personnel. |
| (71) WASHING DETERGENT ALARM ACTIVE CHECK DETERGENT DEVICE | The detergent has run out. | Check and fill with new detergent. |
| (74) POWER GUARD ACTIVATED PART OF EQUIPMENT IS TURNED OFF | | OPTIONAL |
| (77) FINAL RINSE ERROR SENSOR ERROR FLOW METER BV02 | | Reset the alarm using button (10). |
| (76) FINAL RINSE ERROR NO FLOW IN THE MACHINE | The water supply is shut off. | Check that the stopcocks on the incoming water supply are open. Reset the alarm using button (10). |
| (75) FINAL RINSE ERROR LOW FLOW IN THE MACHINE | The rinse nozzles (15) for the final rinse are blocked. | Clean the nozzles. Reset the alarm using button (10). |
| (80) STRAINER STOPPED IN TANK 02. CLEAN FILTER AND PRESS RESET | The strainer (19) and the filter (20) in the final rinse zone are blocked. | Clean the filters. Reset the alarm using button (10). |
| (83) TIME FOR MAINTANANCE CONTACT YOUR MAINTANANCE SUPPLIER | | Contact service personnel. Reset the alarm using button (10). |

5. Technical information

The manufacturer reserves the right to make changes to the technical data.

| TECHNICAL DATA | |
|---|------|
| Pump motor, pre-wash (kW), WD-211E - WD-421E | 1,5 |
| Pump motor, chemical wash 1 (kW) | 1,5 |
| Pump motor, chemical wash 2 (kW), WD-331E - WD-421E | 1,5 |
| Pump motor, chemical wash 3 (kW), WD-421E | 1,5 |
| Pump motor, recirculating rinse (kW) | 0,11 |
| Heat recovery fan (kW) | 0,12 |
| Drive motor (kW) | 0,12 |
| Booster heater 1 (kW), WD-151E | 9 |
| Booster heater 1 (kW), WD-211E - WD-421E | 12 |
| Booster heater 2 (kW), WD-151E | 9 |
| Booster heater 2 (kW), WD-211E - WD-421E | 12 |
| Tank heater, chemical wash 1 (kW), WD-151E -WD-241E | 12 |
| Tank heater, chemical wash 1 (kW), WD-331E - WD-421E | 9 |
| Tank heater, chemical wash 2 (kW), WD-331E - WD-421E | 9 |
| Tank heater, chemical wash 3 (kW), WD-421E | 9 |
| Heat recovery, cooling surface (m ²) | 25 |
| Heat recovery fan, flow (m ³ /hour) | 100 |
| Tank volume, pre-wash (litres), WD-211E | 51 |
| Pump motor, pre-wash (litres), WD-241E - WD-421E | 77 |
| Tank volume, chemical wash tank 1 (litres) | 100 |
| Tank volume, chemical wash tank 2 (litres), WD-331E - WD-421E | 100 |
| Tank volume, chemical wash tank 3 (litres), WD-421E | 100 |
| Tank volume, final rinse tank (litres) | 6 |
| Weight, machine in operation (kg), WD-151E | 490 |
| Weight, machine in operation (kg), WD-211E | 625 |
| Weight, machine in operation (kg), WD-241E | 655 |
| Weight, machine in operation (kg), WD-331E | 900 |
| Weight, machine in operation (kg), WD-421E | 1020 |
| Enclosure class (IP) | 55 |

Technical information

| CAPACITY AND OPERATING DATA | |
|---|---------|
| Normal wash capacity (baskets/hour) *, WD-151E | 70-150 |
| Normal wash capacity (baskets/hour) *, WD-211E | 100-200 |
| Normal wash capacity (baskets/hour) *, WD-241E | 110-210 |
| Normal wash capacity (baskets/hour) *, WD-3351E | 150-230 |
| Normal wash capacity (baskets/hour) *, WD-421E | 150-230 |
| Capacity in accordance with DIN 10510 (baskets/hour), WD-151E | 80 |
| Capacity in accordance with DIN 10510 (baskets/hour), WD-211E | 120 |
| Capacity in accordance with DIN 10510 (baskets/hour), WD-241E | 140 |
| Capacity in accordance with DIN 10510 (baskets/hour), WD-331E | 190 |
| Capacity in accordance with DIN 10510 (baskets/hour), WD-421E | 245 |
| Cold water consumption, normal final rinse (litres/basket) | 1,8 |
| Steam consumption **, (kg/hour), WD-151E | 50 |
| Steam consumption **, (kg/hour), WD-211E -WD-241E | 60 |
| Steam consumption **, (kg/hour), WD-331E | 70 |
| Steam consumption **, (kg/hour), WD-421E | 75 |
| Surface temperature at a room temperature of 20 °C (°C) | 35 |
| Noise level (dB(A)) *** | 68 |

* Maximum capacity 240 baskets/hour.

** When the machine is steam-heated..

*** Measured 1 metre from the side of the machine.

| CONNECTION, ELECTRICALLY HEATED MACHINE | |
|--|------|
| Total connected power (kW), WD-151E | 32,6 |
| Total connected power (kW), WD-211E - 241E | 40,1 |
| Total connected power (kW), WD-331E | 47,6 |
| Total connected power (kW), WD-421E | 58,1 |
| Main fuse 400V 3N~ (A) *, WD-151E | 50 |
| Main fuse 400V 3N~ (A) *, WD-211E - WD-241E | 63 |
| Main fuse 400V 3N~ (A) *, WD-331E | 80 |
| Main fuse 400V 3N~ (A) *, WD-421E | 100 |
| Max. connection area 400V 3N~ (L1-L3, N, PE) Cu (mm ²) | 35 |

* Other voltages on request

Technical information

| CONNECTION, STEAM-HEATED MACHINE 150-250 kPa * | |
|--|------|
| Total connected power (kW), WD-151E | 1,85 |
| Total connected power (kW), WD-211E - WD-241E | 3,4 |
| Total connected power (kW), WD-331E | 4,85 |
| Total connected power (kW), WD-421E | 6,0 |
| Main fuse 400V 3N~ (A) **, WD-151E | 16 |
| Main fuse 400V 3N~ (A) **, WD-211E - WD-421E | 20 |
| Max. connection area 400V 3N~ (L1-L3, N, PE) Cu (mm ²) | 25 |
| Steam (internal thread), WD-151E- WD-241E | R ¾" |
| Steam (internal thread), WD-331E - WD-421E | R 1" |
| Condensing water (internal thread) | R ½" |

* Other pressures available on request.

** Other voltages on request

| WATER, DRAIN AND VENTILATION CONNECTION | |
|---|---------|
| Water quality, hardness (°dH) | 2-7 |
| Hot water connection 50-70 °C (internal thread) | R ½" |
| Cold water connection 5-12 °C (internal thread) | R ½" |
| Drain connection, PP pipe (ø mm) | 50 |
| Water capacity, pressure (kPa) | 250-600 |
| Water capacity, flow (litres/minute) | 11 |
| Floor drain, capacity (litres/second) | 3 |

| SIZE AND WEIGHT FOR TRANSPORT, STANDARD MACHINE * | |
|---|-------------|
| Size ** (LxWxH (m)), WD-151E | 2.1x0.8x2.0 |
| Size ** (LxWxH (m)), WD-211E | 2.7x0.8x2.0 |
| Size ** (LxWxH (m)), WD-241E | 3.0x0.8x2.0 |
| Size ** (LxWxH (m)), WD-331E | 3.9x0.8x2.0 |
| Size ** (LxWxH (m)), WD-421E | 4.8x0.8x2.0 |
| Weight ** (kg), WD-151E | 400 |
| Weight ** (kg), WD-211E | 510 |
| Weight ** (kg), WD-241E | 550 |
| Weight ** (kg), WD-331E | 680 |
| Weight ** (kg), WD-421E | 790 |

* Normal delivery fully assembled. If necessary, delivered in smaller components.

** Including packaging.

CE Declaration of Conformity

This declaration of conformity only refers to the machine/product in the condition in which it is supplied, not any additions or modifications made by the customer/user.

Manufacturer: Wexiödisk AB Mårdvägen 4 S-352 45 Växjö, Sweden Tel: +46 470 77 12 00 Fax: +46 470 237 52

Representative: BF Engineering Services LTD, Rekal doo, Agroznanje doo, Fastus ehf,
M/s Aishwarya Consolidates Pvt Ltd, Nakanishi Mfg Co Ltd, Martin Food Equipment Ltd

Compiler of technical documentation: Magnus Ericsson

Our machines are manufactured 2012 in accordance with applicable EU directives and we declare under sole responsibility that the following products:

Single tank dishwashers with accessories:

WD-4x, WD-6x, WD-7, WD-PRM6/7

Pot wash machines:

WD-12, WD-90x, WD-100GR

Tunnel dishwashers with accessories:

**WD-11, WD-151C/211C, WD-151E/211E/241E/331E/421E, WD-153/213/243/333/423
WD-215T, WD-PRM60/90, WD-T60/60F/80/120, WD-C90/180, WD-BF90/180**

Conveyor dishwashers*:

WD-B xxx, WD-xxCT, WD-40BRE, ACS-38/47

Special dishwashers*:

WD-18CW, WD-25BR, WD-25T, WD-8020/8020W/8020WL/9020/9020W, ACS 400HC, ACS 800

Conform to the following directives:

EU Declaration of Conformity

according to EU's Machinery Directive 2006/42/EG, annex IIA.

Harmonised standards

- EN 12 100-1 Machine safety: specification for general requirements, part 1
- EN 12 100-2 Machine safety: specification for general requirements, part 2.
- EN 60 204-1 Machine safety: electrical equipping of machines: general requirements

EU Declaration of Conformity

according to EU's Low-voltage directive 2006/95/EC.

Harmonised standards

- EN 60 529 Specification for degrees of protection provided by enclosures (IP code).

For products marked with *

- EN 60 204-1 Machine safety: electrical equipping of machines: general requirements

For other products

- EN 60 335-1 Safety of household and similar electrical appliances - General requirements.
- EN 60 335-2-58 Specification for safety of household and similar electrical appliances. Particular requirements. Commercial electric dishwashing machines.
- EN 50106 Safety - Particular rules for routine tests.

EU Declaration of Conformity

according to EU's EMC-directive 2004/108/EC.

Harmonised standards

- EN 61 000-6-2 Electromagnetic compatibility (EMC). Generic standards. Immunity standard for industrial environments.
- EN 55 014-1 Electromagnetic compatibility. Requirements for household appliances, electric tools and similar apparatus. (EMC) - Part 1: Emission

Växjö 2012-01-02

Torsten Nyberg
Managing Director