



# TECHNICAL INSTRUCTION

---

La San Marco S.p.a.

# PLUS 5

EN

ENGLISH



---

**cod. 7770.046**  
EDITION October 2009



# TABLE OF CONTENTS

INTRODUCTION AND GENERAL INSTRUCTIONS.....	3
INSTRUCTIONS FOR INSTALLATION .....	3
SPECIAL INSTRUCTIONS FOR USE AND MAINTENANCE .....	3
GENERAL CHARACTERISTICS .....	4
TEST REPORT ON ENERGY CONSUMPTION.....	4
MACHINE KEYPAD.....	5
ELECTRIC - HYDRAULIC CONNECTION.....	6
STARTING UP.....	7
ACCESS THE MAIN SETTING MENUS WITH PASSWORD OR SMART-CARD.....	11
PROGRAMMABLE PARAMETERS IN ACCORDING WITH SMART CARD OR PASSWORD.....	13
INFO-RESET .....	15
DOSES PROGRAMMING .....	19
SYSTEM MANAGER .....	27
MACHINE CONFIGURATION.....	28
MACHINE PARAMETERS.....	30
SYSTEM CLOCK SET-UP .....	33
DISPLAY REGULATION .....	34
SERVICE .....	35
SMART CARD MANAGER.....	40
CHANGE PASSWORD.....	42
GROUP MANUAL MOVEMENTS .....	43
TEST ACTUATORS.....	44
BOILER DRAINING .....	48
ALARM HISTORY .....	49
PRESET PARAMETERS .....	50
CLEANING PROCESS ABORT.....	51
TROUBLE SHOOTING .....	52
SPECIAL FUNCTIONS FOR MACHINE CALIBRATION .....	59
RECOMMENDATIONS FOR A CORRECT PREVENTIVE MAINTENANCE.....	61
CONTROL UNIT LEGEND.....	62

## INTRODUCTION AND GENERAL INSTRUCTIONS

Thoroughly read the instructions contained in this booklet because it gives important information regarding safety for installation, use and maintenance.

Keep this booklet in a safe and accessible place for further consultation.

This is a commercial appliance and must be installed and serviced only by La San Marco S.p.A. Authorised personnel

This machine must be used only for the purpose it was designed:

dispensing coffee, cappuccino and pouring hot water

Any other use is to be considered inappropriate and therefore dangerous.

The manufacturer declines all responsibility for damage caused by any improper, incorrect and unreasonable use of the machine.

The use of any electric appliance implies the observance of some fundamental rules.

More specifically:

- do not touch the appliance with your hands or feet wet or damp
- do not use the appliance with bare feet
- do not pull the power cord to disconnect the plug from the power socket
- do not leave the appliance exposed to the weather (rain, sun, frost)
- do not let children or untrained persons use the appliance.

Before carrying out any cleaning and maintenance, disconnect the appliance from the power supply, pulling the plug from the power socket and turning off the main switch.

In case of failure or malfunction turn the machine off and do not attempt to carry out any repairs or direct operations on the machine.

All repairs must be carried out in a La San Marco S.p.A Authorised Service Centre, using original spare parts only.

Failure to comply with the above recommendations will compromise the safety of the machine and the warranty conditions.

If this machine is no longer used, we recommend that it is made inoperative by disconnecting the power cord and water tube from the power supply, and all potentially dangerous parts are made harmless, especially to protect children who might use the machine for their games.

## INSTRUCTIONS FOR INSTALLATION

Installation must be carried out according to the manufacturer's instructions.

An incorrect installation can cause damage to persons, animals or things; the manufacturer declines all responsibility for such situation.

After unpacking check that the machine is not damaged.

If in doubt, do not use the machine and contact a La San Marco S.p.A Authorised Service Centre.

All packing materials (plastic wrapping, polystyrene, nails, etc.) are potentially dangerous and must be kept out of children's reach and disposed of in a safe manner for the environment.

Before connecting the machine to the power supply make sure that the rating information of the machine correspond to that of the power supply; if the power socket is not compatible with the plug of the machine (if supplied), replace the socket with a proper one, ensuring that the size of the cable is suitable for the absorbed power of the machine. If you replace the power cord, use an H07RN-F cord again.

Make sure that the voltage rating of the machine corresponds to that of the power supply, and that the power supply is adequate to additional power absorption of the machine.

After installing the main switch and fuses (see annex), connect the power cord of the machine to the main switch according to the attached electrical diagram.

The use of adapters, multiple power boards and extension cords is not recommended.

If it is absolutely necessary, then use only single or multiple adapters and extension cords which comply with current safety regulations, ensuring also that the electricity load capacity of the single adapters and extension cords and the maximum power rating of the multiple adapters is suitable.

The electrical safety of this machine can be guaranteed only if correctly connected to an efficient earth circuit as indicated by current electrical safety regulations.

It is necessary to check this fundamental safety prerequisite, and in case of doubt, ask a professionally qualified technician to check the circuit.

The manufacturer declines all responsibility for any damage caused by failure to earth the machine.

In order to avoid any dangerous overheating, we recommend that the power cord be fully unwound.

The power cord of this machine must not be replaced by the customer.

In case of damage to the cord, contact exclusively a La San Marco S.p.A. Authorised Service Centre.

Do not leave the machine connected unnecessarily.

Turn off the main switch of the machine when not in use.

Do not cover the ventilation openings of the machine.

Place the machine at an adequate distance from walls, objects, etc.

The machine must be connected to a system with a water pressure, which is not greater than 5 bar. (Kg/cm<sup>2</sup>).

If the pressure is greater, a pressure reducer must be installed.

Install a water softener above the machine.

### ENVIRONMENTAL CONDITIONS TO USE THE MACHINE

Environmental temperature: 5 – 45 °C (empty the hydraulic system in case of freezing)

Maximum humidity: 80% relative humidity

Water hardness: 5° eh, 7° dH, 13° Fh

## SPECIAL INSTRUCTIONS FOR USE AND MAINTENANCE

For a correct functioning of the machine it is fundamental to comply with the manufacturer's instructions, having qualified personnel to carry out ordinary maintenance and to check all safety devices.

Avoid exposing hands or other parts of the body to the coffee dispensing spouts or to the hot water nozzle. The water from the nozzle is very hot and can cause severe burns.

The water nozzle is very hot and therefore must be handled with care, holding it in the appropriate point.

Do not use the machine without water.

Do not leave the machine in rooms where the temperature is below zero °C or 32 °F without having first drained the boiler and the hydraulic circuit.

A softener needs to be used where the water is very hard and where the calcareous scaling is particularly extensive.

In any case, regularly check the boiler even where the water is not very hard, and if necessary, have the resistors and tubing descaled by specialised technicians.

**Failure to clean La San Marco S.p.A machines daily, especially for brewing unit and milk frother, using approved cleaning products and following specified cleaning procedure will result in void warranty and service contract.**

### NOTE:

**A) THE REGISTRATION AND TECHNICAL DATA PLATE OF THE MACHINE IS BEHIND THE GROUND BIN.**

**B) THE EQUIPMENT SHALL BE INSTALLED IN COMPLIANCE WITH FEDERAL, STATE AND LOCAL REGULATIONS.**

## GENERAL CHARACTERISTICS

MACHINES VERSION	PLUS 5
Number of coffee dispensing groups	1
Number of grinders	1/2
Number of dispensers/mixer	1/ 2
Number of product containers	1/ 2
Hot water dispenser	1
Maximum quantity of dispensable drinks per minute	2 Espresso 1 Coffee 1 Cappuccino 1 Choco
Maximum quantity of dispensable hot water per hour	10 l.
Machine width (mm)	325
Machine height (mm)	725
Machine depth (mm)	560
Net weight (Kg)	35
Coffee hopper capacity gr.	650
Container capacity choco sx. (lt.)	2
Container capacity topping dx. (lt.)	2
Coffee Boiler capacity (lt)	1
Steam Boiler capacity (lt)	1
Coffee Boiler resistor (W) for machine with rotation pump	1800
Coffee Boiler resistor (W) for machine with vibration pump	1200
Steam Boiler resistor (W)	1200
Voltage (V)	100V-1+N – 50/60Hz 120V-1+N – 50/60Hz 200V-1+N – 50/60Hz 200V-3 – 50/60Hz 220V-1+N – 50/60Hz 230V-1+N – 50/60Hz
Brewer group resistor PTC (W)	70

### Materials used:

- Stainless steel for boiler
  - Teflon/Copper for hydraulic tubes
  - Aluminium with stainless steel lining for the brewing group
  - Plastic for grinder with conic grinder blades.
  - Other accessories in food plastic which are in contact with the ground coffee or drink
  - Plastic for working area and cups tray.
- Painted metal or stainless steel for machine body

## TEST REPORT ON ENERGY CONSUMPTION

Machine type: PLUS 5 LM 230V 1N Coffee boiler heating element 1.8 KW, boiler 1 lt Steam boiler heating element 1.2 KW, boiler 1 lt Machine load 0,15 KW Environment temperature: 20°C	MEASUREMENT
1. HEAT UP PHASE To reach operational coffee boiler temperature, 90°C, in 2'.21" (min, sec) To reach operational steam boiler temperature, 124°C, in 6'.00" (min, sec)	Consumption 0.15 KW/h HU = 150 W
2. IDLE PHASE Stand by at coffee boiler 90°C and steam boiler 124°C during 24 hours	Consumption 3.2 KW/24h IM = 3200 W, 133,33 W/h
3. VENDING PHASE Delivery of No. 30 cups of coffee of 100ml, one cup every 2 minutes	L = ml 90 DV = ml 2700 VM = 350 W/h (vending phase) DT = 87,4° C (average drink temperature) ECPL = 129,6 W/h (energy consumption per litre)

## MACHINE KEYPAD

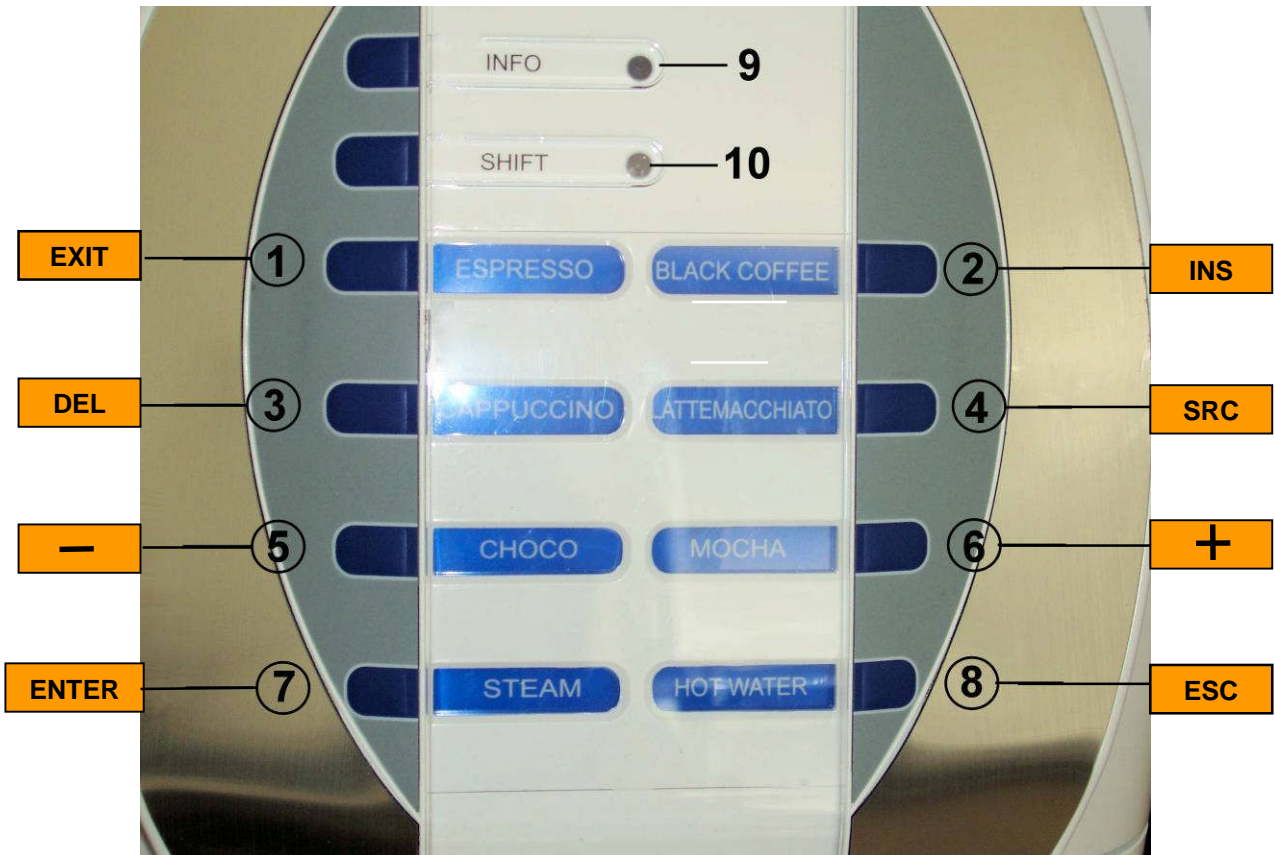

KEY REFERENCE	PLUS 5
1	EXIT ( edit ) / Espresso
2	INS ( Insert blank ) / Black coffee
3	DEL ( Delete character ) / Cappuccino
4	SCROLL / Latte macchiato
5	- / Choco
6	+ / Mocha
7	ENTER / Steam
8	ESC / Hot water
9	INFO
10	SHIFT /CLEAN

# ELECTRIC - HYDRAULIC CONNECTION

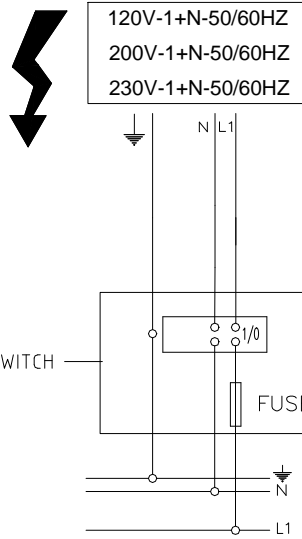
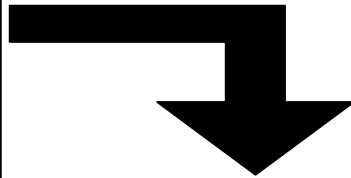

H2O OUT

WATER SOFTNER

WATER FILTRE

H2O IN  
(1-5 Bar)

## STARTING UP

**WARNING : ALL PARAMETERS THAT CONCERN THE STEAM BOILER WILL NOT BE DISPLAYED IN PLUS 5 EASY MACHINES.**

After having connected the machine to the water and electric networks, turn the switch on (see diagram).  
The display shows:

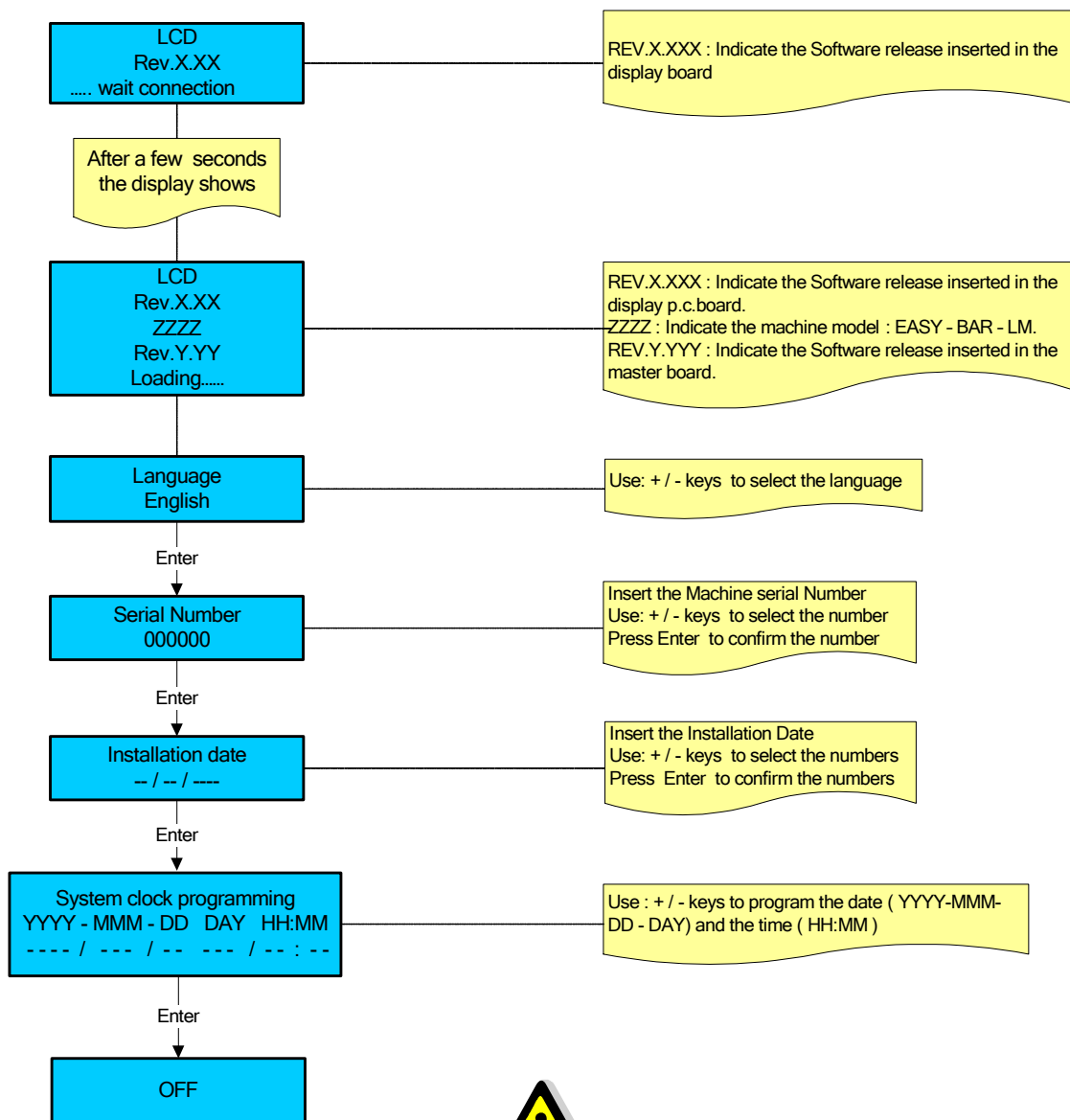

**WARNING:**

**A - If the language choice is not displayed, keep the machine in OFF mode; it is absolutely necessary to carry out a TECHNICIAN PRESET CONFIGURATION DATA procedure.**

**B - If a FACTORY PRESET CONFIGURATION DATA has been carried out , also the MACHINE CONFIGURATION parameters will be displayed . ( See the System manager paragraph ).**

keep key n°10 (shift) pressed and then press key n° 9 ( info), and the machine will set itself to on state.

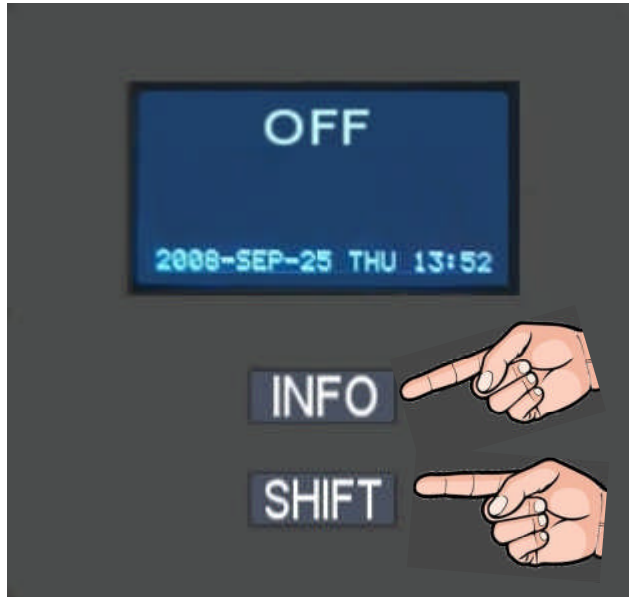

, the display shows:

Filling - up steam boiler

During this stage the steam boiler is being filled up.

**WARNING:** The solenoid valve of the steam nozzle automatically opens to release the air inside the boiler. When the steam boiler has been filled up, the display shows:

Filling - up coffee boiler  
Press T 1  
When water exits

During this stage the coffee boiler is being filled up

**WARNING:**

The upper piston of the coffee group positions itself inside the brewing chamber, and the coffee boiler starts filling up. When the coffee spout starts dispensing water, press the key dose N° 1 to confirm that the filling up procedure has been carried out. When the coffee boiler has been filled up, the display shows:

Steam      Coffee  
XXX °C      YYY °C

Where:

- XXX °C indicates the temperature of the steam boiler
- YYY °C indicates the temperature of the coffee boiler

**WARNING:**

**A) DURING THIS STAGE THE MILK FROTHER AND STEAM WAND SOLENOID VALVES WILL STAY OPEN UNTIL 95°C. THIS WILL RELEASE THE AIR FROM THE BOILER AND GENERATE STEAM.**

**B) WHEN THE BOILER TEMPERATURE OF 50°C ITS REACHED THE MACHINE CARRY-OUT A RINSING GROUP .THIS IS USEFULL TO RELEASE AIR FROM THE WATER COFFEE CIRCUIT; THE DISPLAY WILL SHOW :**

G.Auto cleaning

When the set-up temperature is reached , the keypad lights are on and the display shows:  
For machine configurations: Standard.

Select drink



For machine configurations: Self.  
The display shows:

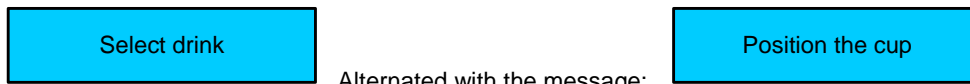

For machine configurations: waiters' card  
The display shows:

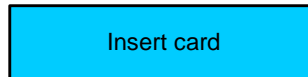

For machine configurations: Self + credit card  
The display shows:

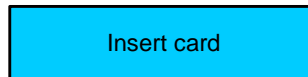

For machine configuration: Self with coin box.  
The display shows:

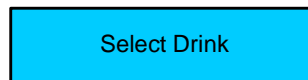

For machine configuration: Self with coin box + credit card.  
The display shows:

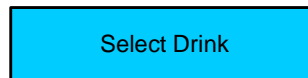

**WARNING:**

- a) For Self with coin box configuration the selections doses are enabled only when the set-up temperature of both boilers ( Coffee- Steam ) have been reached.
- b) To switch ON the machine on every type of Self – configuration, keep key n°10 (shift) pressed and then press key n° 9 ( info), before closing the machine front door .  
To switch OFF the machine, open the front door or place the smart card and keep key n°10 (shift) pressed and then press key n° 9 ( info), ; or keep key n°10 (shift) pressed for 5 seconds, and after insert the password, the display shows:

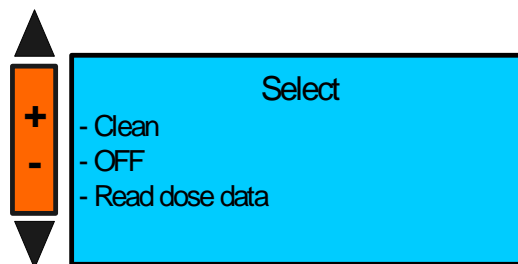

Press the key n°6 ( + ) to select OFF and then press the key n°7 ( Enter ) to confirm.

- c) In case of temporary voltage drop, the machine will be automatically turned back to the stage previous to the voltage drop.  
If the display shows:

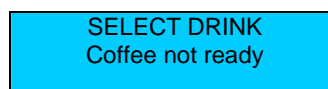

The displayed message indicates that the set up heating temperature in the coffee boiler has not been reached yet, and therefore coffee based dispensing are not enabled  
If the display shows:

**SELECT DRINK**  
 Steam not ready

The displayed message indicates that the set up heating temperature in the steam boiler has not been reached yet, and therefore milk based dispensing and hot water dispensing are not enabled. In both cases wait until the boiler has reached the set up heating temperature.

**SCHEMATIC SUMMARY OF STEAM AND COFFEE BOILER HEATING PHASE**

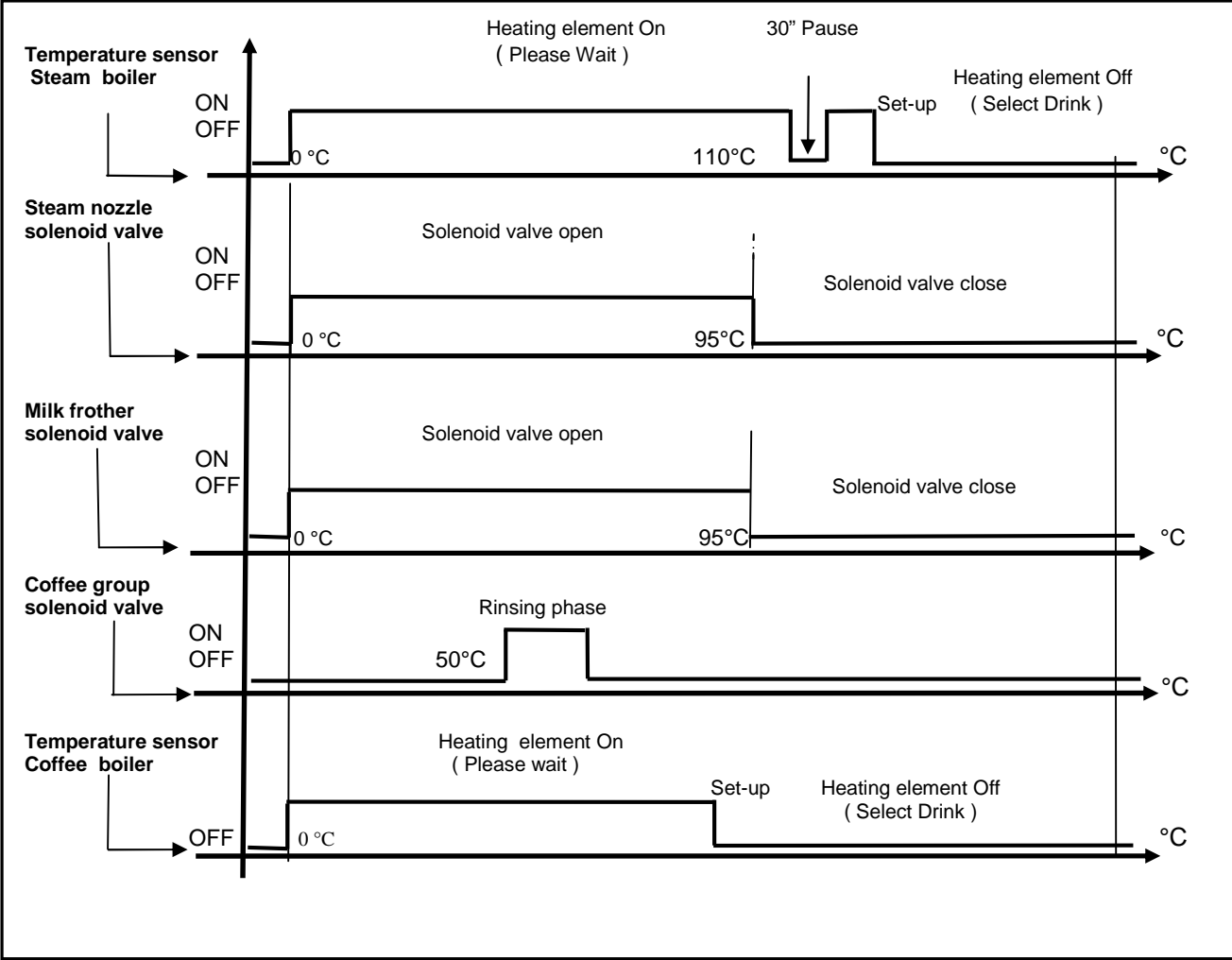

## ACCESS THE MAIN SETTING MENUS WITH PASSWORD OR SMART-CARD

### A) ACCESS THE MAIN SETTING MENUS WITH PASSWORD

To enter the programming environments, a password is required which define the access rights to the different environments.

The password must be composed with 5 numbers.

To insert the passwords proceed as follows:

- Turn the machine OFF
- Keep N°10 "SHIFT" key pressed for 5 seconds. The display shows:

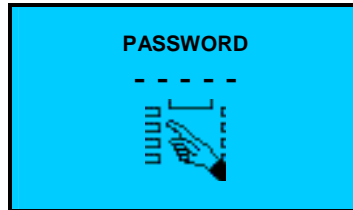

Enter one of the following passwords:

- Waiter                    6 1 1 1 1
- Roaster                   1 1 1 1 1
- Owner                    2 2 2 2 2
- Service                   3 3 3 3 3
- Technician                ( for Technician password contact the La San Marco S.p.A. Technical Service ).

After insert the password the display shows the main menu programming environments:

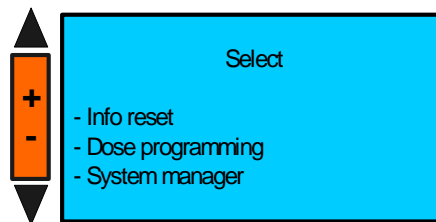

### KEY REFERENCE FOR PASSWORD

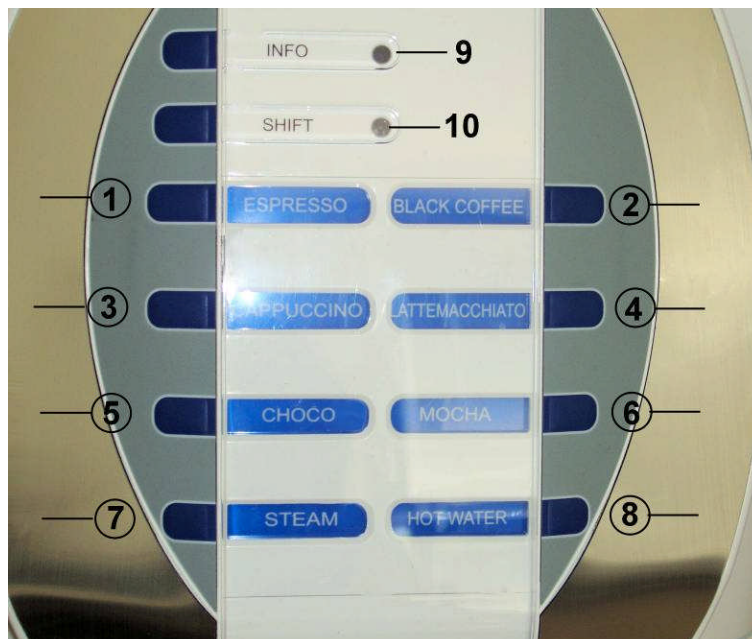

**B) ACCESS THE MAIN SETTING MENUS WITH SMART CARD.**  
( ONLY FOR MACHINES WITH TRANSPONDER INSTALLED )

To enter the programming environments , place one of the following smart cards above the proper reader with the led light on and the machine in off :

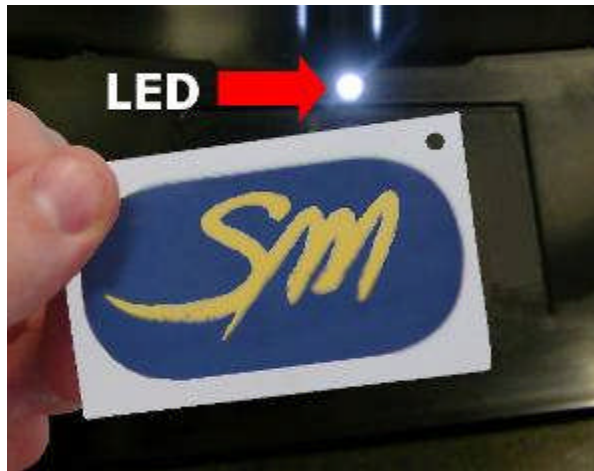

- WAITER SMART CARD
- ROASTER- SMART CARD
- OWNER SMART CARD
- SERVICE SMART CARD
- TECHNICIAN SMART CARD

if the inserted card it is correct the reader led light off .  
Keep N°10 "SHIFT" key pressed for 5 seconds. The display shows:

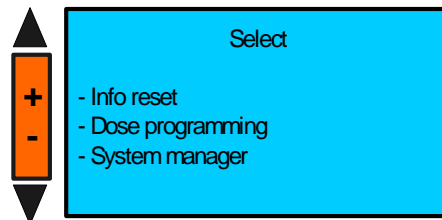

**WARNING:**

If you use a card having a card code different from the machine code, the reader light flash simultaneously.

**PROGRAMMABLE PARAMETERS IN ACCORDING WITH SMART CARD OR PASSWORD**

		WAITER	ROASTER	OWNER	SERVICE	TECHNICIAN
<b>INFO - RESET</b>						
Reard dose data	Douse counter A	X	X	X	X	X
	Douse counter B	X	X	X	X	X
System data	Group cleaning				X	X
	Whisk cleaning				X	X
	Milker cleaning				X	X
	Grinder cycles				X	X
	Water filter				X	X
	Group cycles				X	X
	Total group cycles				X	X
	Total machine cycles				X	X
<b>DOSE PROGRAMMING</b>						
	Dose slight Adj.	X	X	X	X	X
	Set doses				X	X
	Price set-up			X	X	X
	Grinder-milker calib.				X	X
	Instant dispenser Calib.					X
<b>MACHINE CONFIGURATION</b>						
	Pump type					X
	N° of Dispenser - Mixer					X
	Steam boiler					X
	Milker					X
	Milk pump					X
	Machine type					X
	Remote controller					X
<b>MACHINE PARAMETER</b>						
	Language				X	X
	Water tank				X	X
	Serial			X	X	X
	Ground N°	X	X	X	X	X
	Milk pump position				X	X
	Milk pump time pre				X	X
	Milk pump time post				X	X
	Rinse after milk dose					X
	Pause after milk					X
	Waiting time milk dose A - B					X
	Additional Milk					X
	Decimal price					X
	Scale factor price					X
	Multi vending					X
	Token					X
	Max credit on card					X
	Alarm detail					X
	Temp. Misure unit					X
	Coffee temperature	X°	X°	X°	X	X
	Steam temperature	X°	X°	X°	X	X
	Sequential heater				X	X
	Keyboard sound				X	X
	Gsm: Sim card pin				X	X
	Gsm: Service phone number				X	X
	Modem set-up parameters				X	X
	Remote password				X	X
	User vmessage	X	X	X	X	X
	Serial N°				X	X
	Installation date				X	X

<b>SYSTEM CLOCK PROGRAMMING</b>						
	YY-MM-DD Day HH:MM	X°	X°	X°	X	X
	Clock display			X	X	X
	Auto start -up			X	X	X
	On - Off			X	X	X
	Day Off			X	X	X
<b>DISPLAY REGULATION</b>						
	Contrast			X	X	X
	Display mode			X	X	X
	Default colour			X	X	X
<b>SERVICE</b>						
Clean/Rinse	Cleaning time	X		X	X	X
	Cycle cleaning alarm					X
	Group cleaning Programming					X
	Group auto rinsing		X	X	X	X
	Whisk cleaning program					X
	Whisk rinsing					X
	Milker cleaning program.					X
	Milker auto rinsing					X
Maintenance set -up						
	Waiter filter				X	X
	Machine service				X	X
	Grinders				X	X
	Group cycles				X	X
<b>SMART CARD MANAGER</b>						
	System code				X	X
	Credit load			X	X	X
	Enable/disable waiter N°			X	X	X
<b>CHANGE PASSWORD</b>						
	Roaster		X	X	X	X
	Owner			X	X	X
	Service				X	X
	Technician					X
<b>GROUP MANUAL MOVEMENTS</b>						
	Group manual movements				X	X
<b>TEST ACTUATORS</b>						
	Test actuators				X	X
	Milk pump speed				X	X
	Mixer test				X	X
	Dispenser test				X	X
	Exhaust fan test				X	X
<b>BOILER DRANING</b>						
	Boiler draining				X	X
<b>ALARM HISTORY</b>						
	Alarm history	X°	X°	X°	X	X
<b>PRESET CONF. DATA</b>						
	Preset configuration data				X	X

Where X indicate the available program and X° indicate the partial available program.

N.B. :

A) If the “ PRESET CONFIGURATION DATA “ is done with the Service smart card or password will be reseted only the service accessible parameters.

**INFO-RESET**

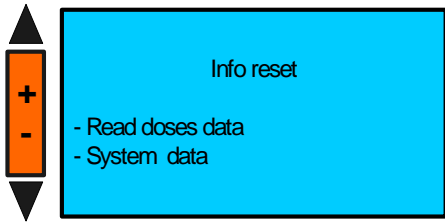

**A1) READ DOSES DATA ( Doses counter A/B )**

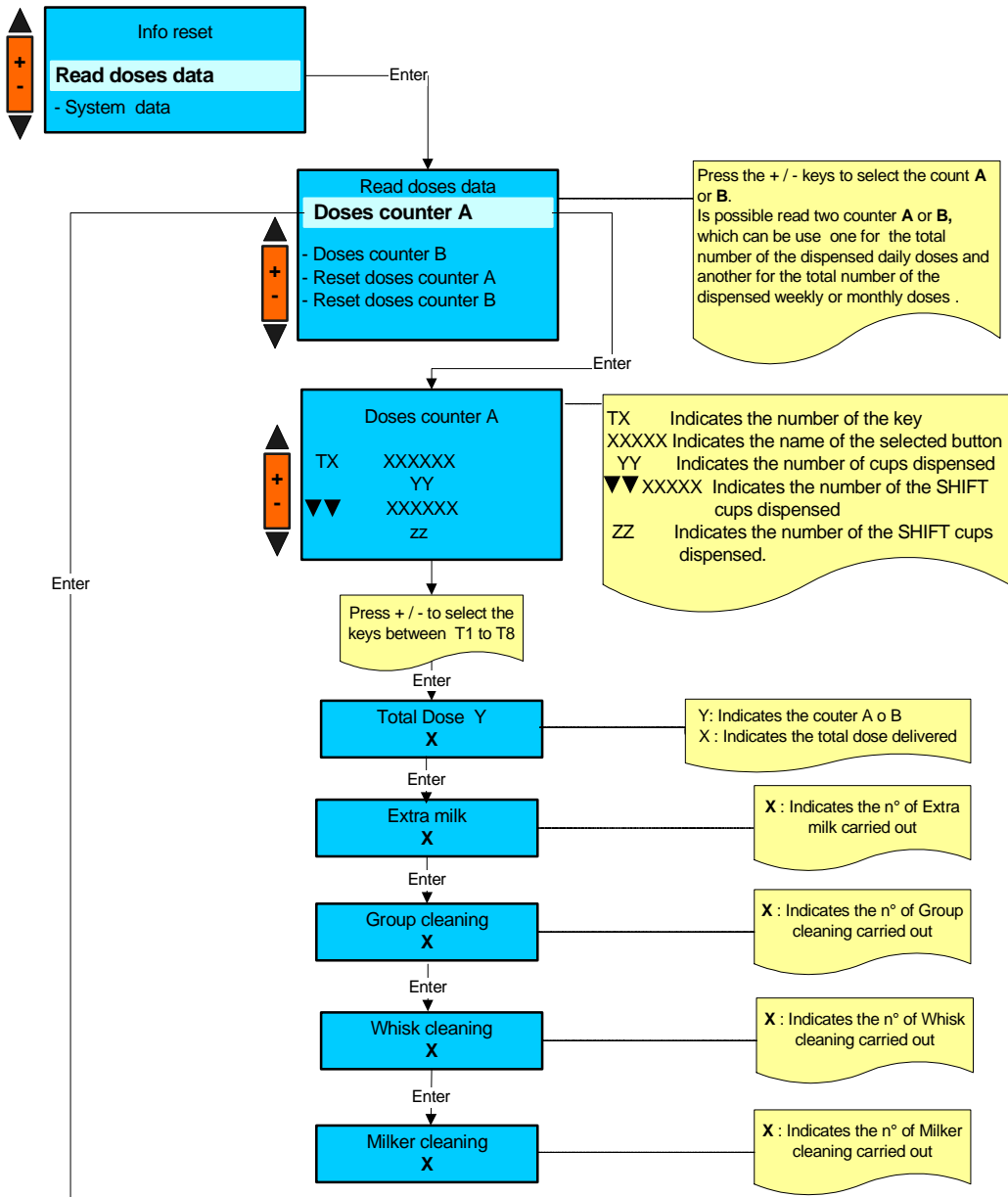

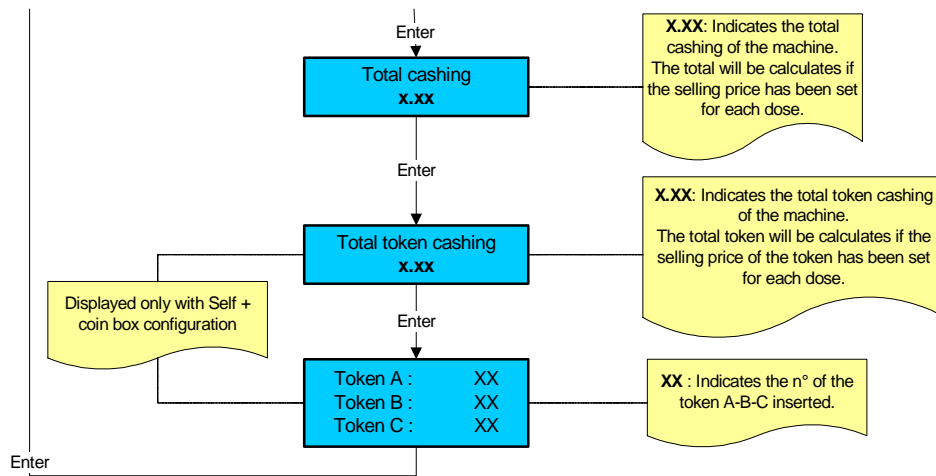

**A2) READ DOSES DATA ( Reset doses counter A/B )**

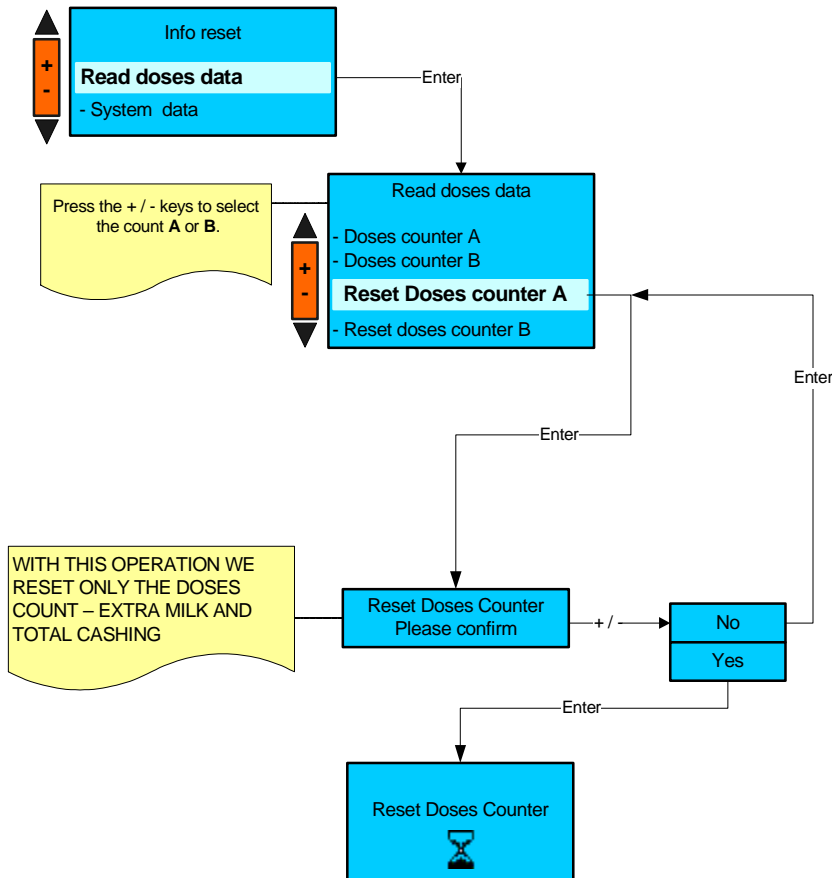



## B) INFO RESET SYSTEM DATA

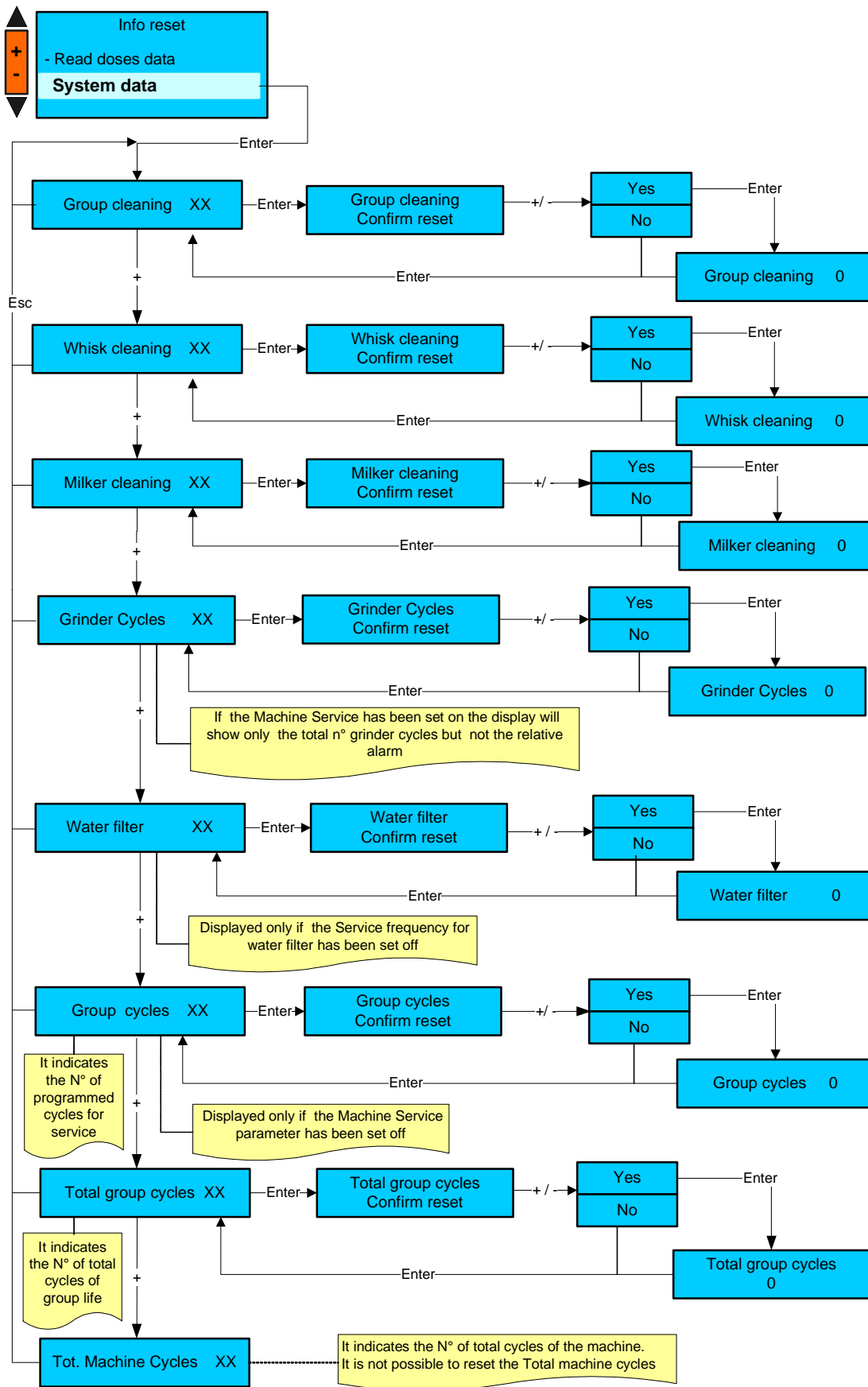

**THE FOLLOWING INFO ARE DISPLAYED ONLY WHEN THE CLOCK IS PROGRAMMED**

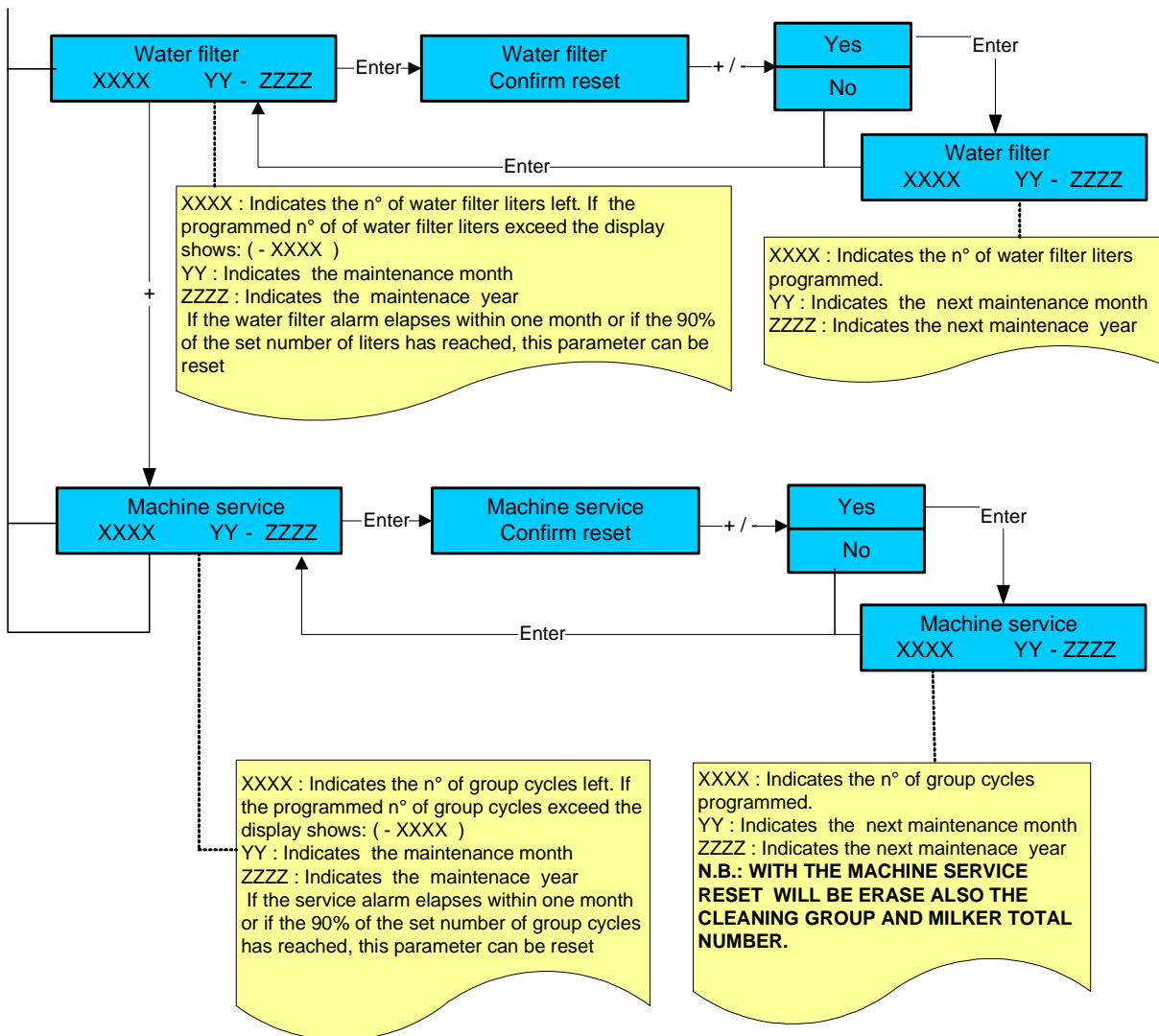

**WARNING:**

The owner's card can only enter total dose reset environment and water softener alarm reset.  
Environments: group cycles, M1 tools time, M2 tools time and water filter litres will be displayed only if values higher than 000 (zero) have been set during the programming stage.

# DOSES PROGRAMMING

**PLEASE NOTE :**  
**TO ACCESS TO THE DOSES PROGRAMMING THE MACHINE MUST BE AT THE SET-UP TEMPERATURE.**

Press the key No 5 (-) and No 6 (+) to select the parameter and then press the key No 8 (Enter) to confirm the selection.

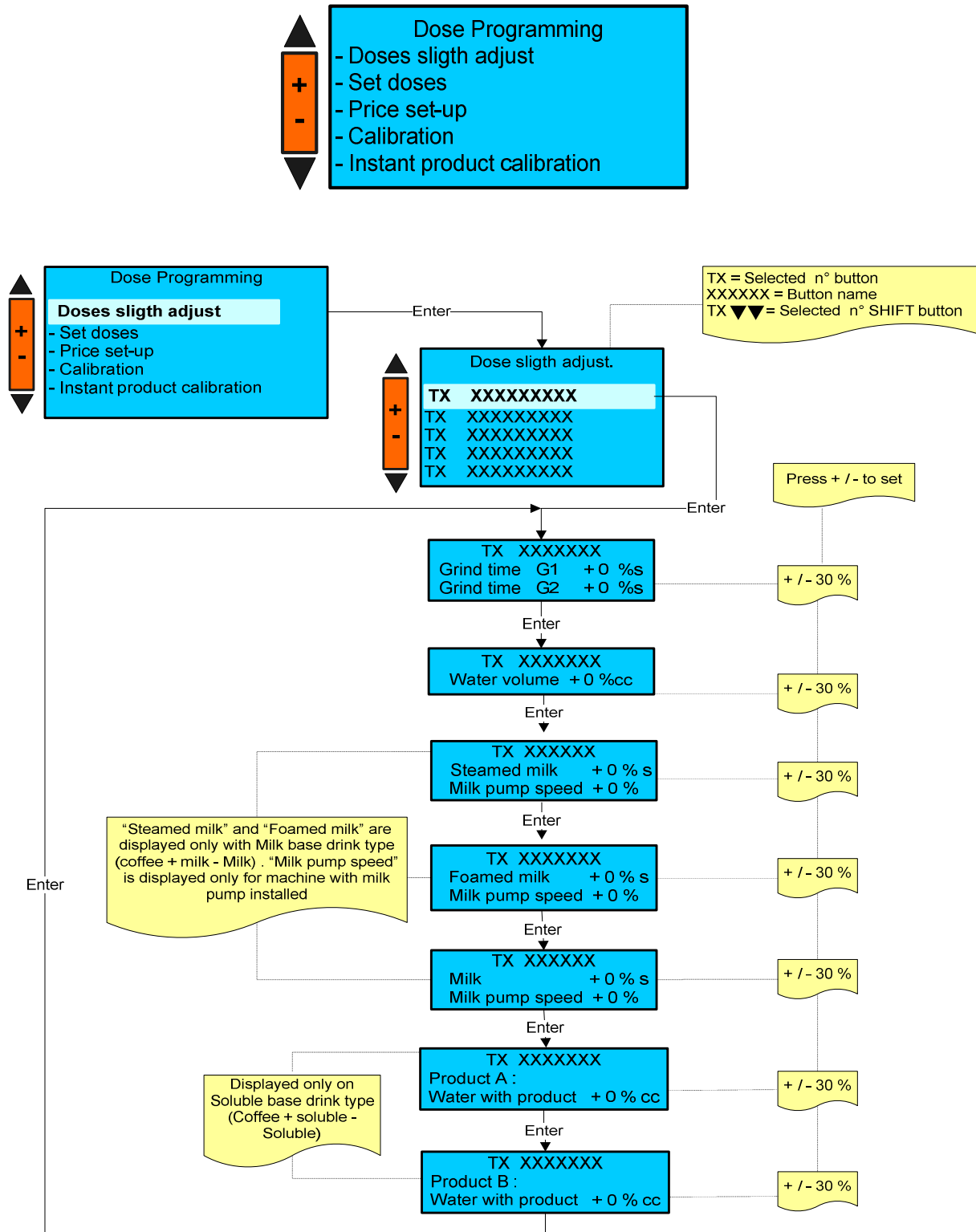

## A ) DOSES SLIGHT ADJUSTMENT

## B) SET DOSES

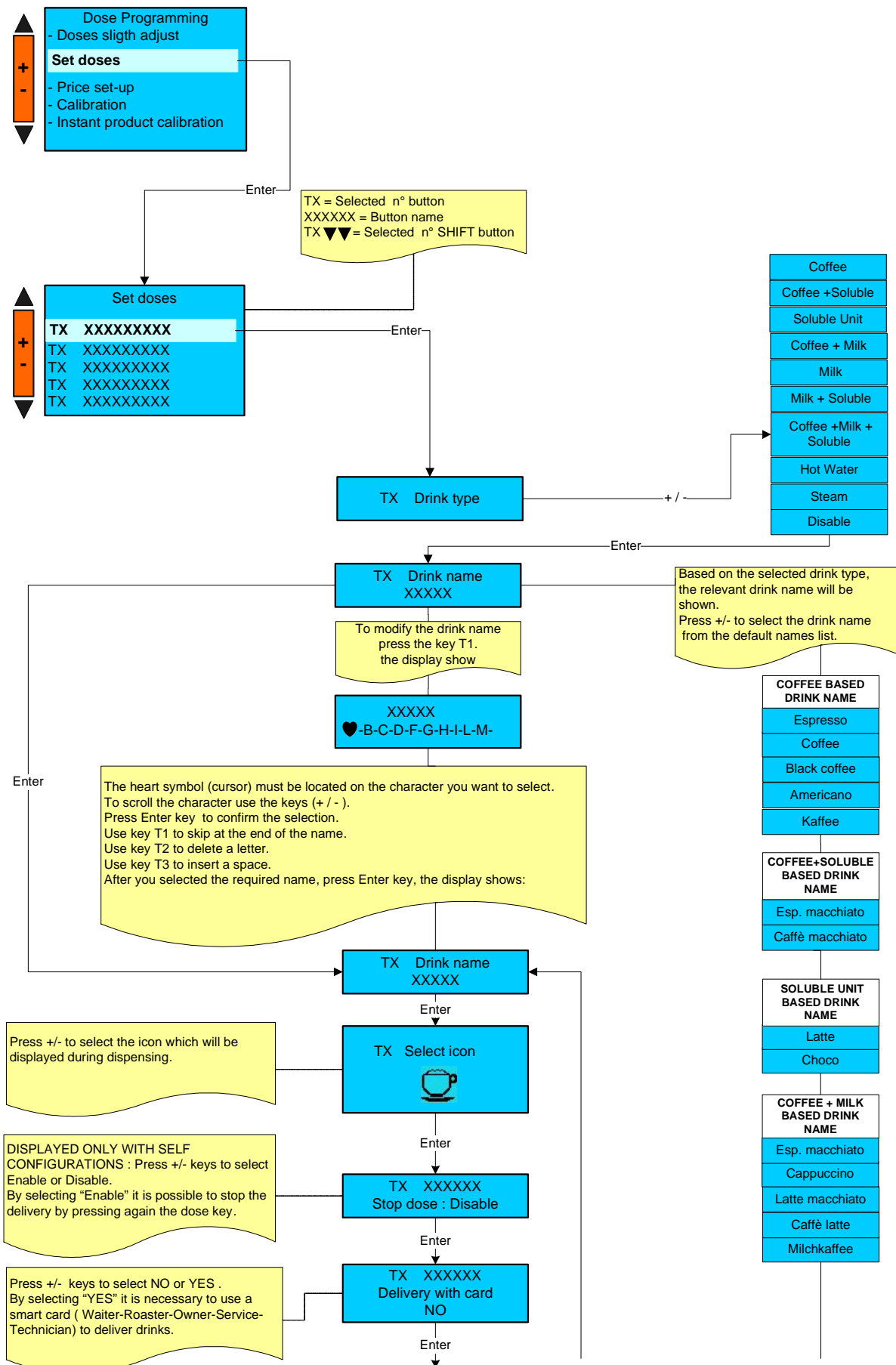

Press Enter key to go to the next programming doses level.  
( SEE FOLLOWING TABLE )

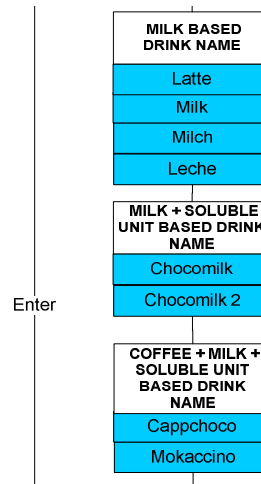

DOSE PARAMETERS	Coffee Drink type	Coffee+ Soluble Drink type	Soluble Drink type	Coffee+ Milk Drink type	Milk Drink type	Milk + Soluble Drink type	Coffee+ Milk + Soluble Drink type	Hot Water drink type	Steam
PRODUCT A : PRE	-	X	X	-	-	X	X	-	-
PRODUCT A : POST	-	X	X	-	-	X	X	-	-
PRODUCT B : PRE	-	X	X	-	-	X	X	-	-
PRODUCT B : POST	-	X	X	-	-	X	X	-	-
DECAFFEINATED	X	X	-	X	-	-	-	-	-
GRIND TIME G1-2	X	X	-	X	-	-	X	-	-
PRE-INFUSION ml. PAUSE sec.	X	X	-	X	-	-	X	-	-
WATER VOLUME ml.	X	X	-	X	-	-	X	X	-
EXTRA WATER ml.	X	X	-	X	-	-	X	-	-
START COLD WATER cc.	X	X	-	X	-	-	X	-	-
COLD WATER ml. ON	X	X	-	X	-	-	X	-	-
COLD WATER ml. OFF	X	X	-	X	-	-	X	-	-
PRODUCT A . COLD WATER Yes / No	-	X	X	-	-	X	X	-	-
PRODUCT A Water with product ml.	-	X	X	-	-	X	X	-	-
PRODUCT A Whisk speed Xx %	-	X	X	-	-	X	X	-	-
PRODUCT DENSITY A aaa gr./100ml (GGG gr./100 ml)	-	X	X	-	-	X	X	-	-
PRODUCT B . Water with product ml.	-	X	X	-	-	X	X	-	-
PRODUCT B . Whisk speed Xx %	-	X	X	-	-	X	X	-	-
PRODUCT DENSITY B aaa gr./100ml (GGG gr./100 ml)	-	X	X	-	-	X	X	-	-
Solu. Drink pause Sec.	-	X	X	-	-	X	X	-	-
COFFEE TEMPERATURE°C-°F	X	X	-	X	-	-	X	-	-
REPETITION CYCLE	X	-	-	-	-	-	-	-	-
COLD MILK : Enable/Disable MILK sec.	-	-	-	X	X	X	X	-	-
MILK PUMP SPEED Xx %	-	-	-	X	X	X	X	-	-
EXTRA MILK	-	-	-	X	X	X	X	-	-
STEAM MILK PRE sec MILK PUMP SPEED Xx %	-	-	-	X	X	X	X	-	-
FOAMED MILK PRE sec MILK PUMP SPEED Xx %	-	-	-	X	X	X	X	-	-
PAUSE MILK-COFFEE se	-	-	-	X	X	X	X	-	-
STEAM MILK POST sec MILK PUMP SPEED Xx %	-	-	-	X	X	X	X	-	-
FOAMED MILK POST sec MILK PUMP SPEED Xx %	-	-	-	X	X	X	X	-	-
CODE I/O	X	X	X	X	X	X	X	X	X
CODE I/O EXTRA-MILK	-	-	-	X	X	X	X	-	-
STEAM TIME	-	-	-	-	-	-	-	-	X
DELIVERY TEST	X	X	X	X	X	X	X	-	-

Depending on the drink type, the necessary dose parameters will be activated to set the drink.  
 Press the key N°7 (Enter) to confirm the modification carried out and shift to the next level.  
 Press the key N°6 (+) and No5 (-) to modify the level mode.  
 Press the key N°8 ( Esc) to return to the previous environment and/or exit.

**Please note:**

- A) Some dose parameters will be displayed only if the relevant component has been activated in the "MACHINE PARAMETERS" environments : **milker- interface i/o hartwall or coin mechanism.**
- B) For Coffee + Milk and Milk drink type the "repetition cycle "is not available.
- C) The "Milk pump speed and Cold milk parameters" will be displayed only for machine with the milk pump installed.

**PURGE FUNCTION**

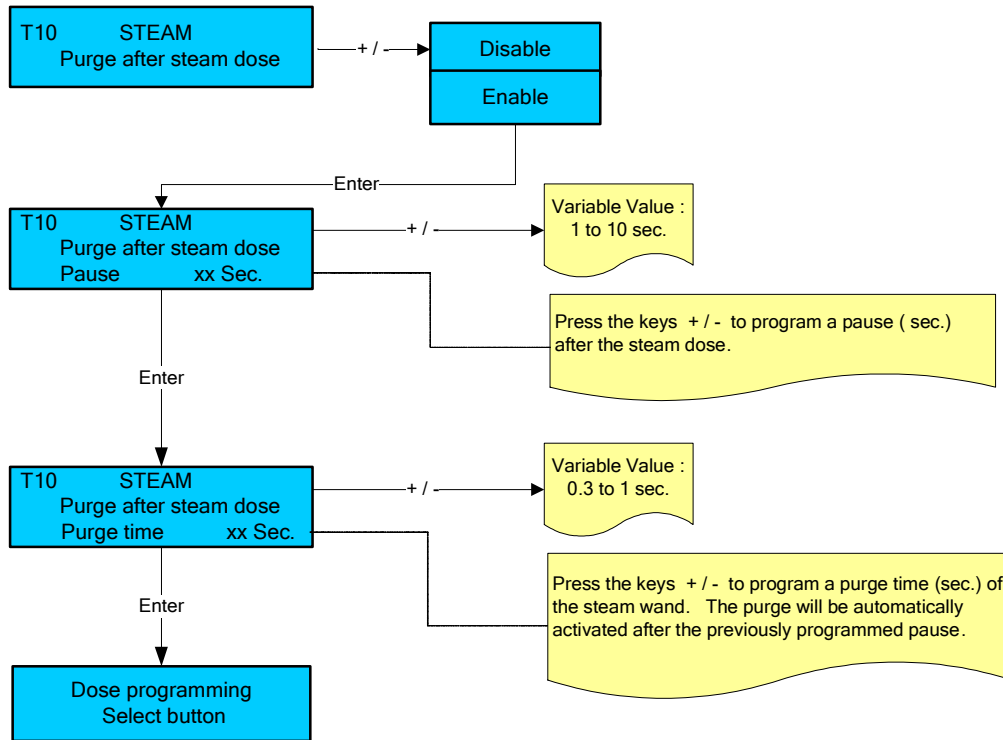

**C ) PRICE SET-UP**

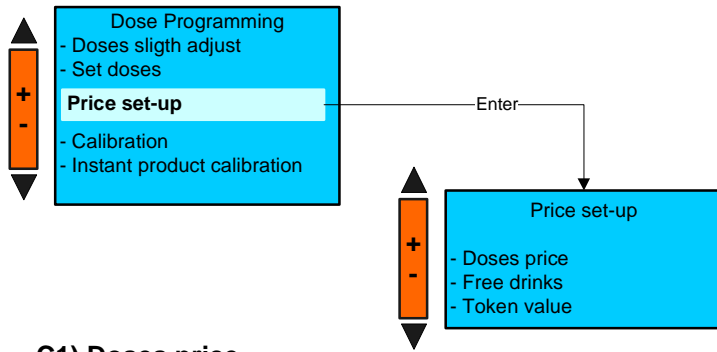

**C1) Doses price**

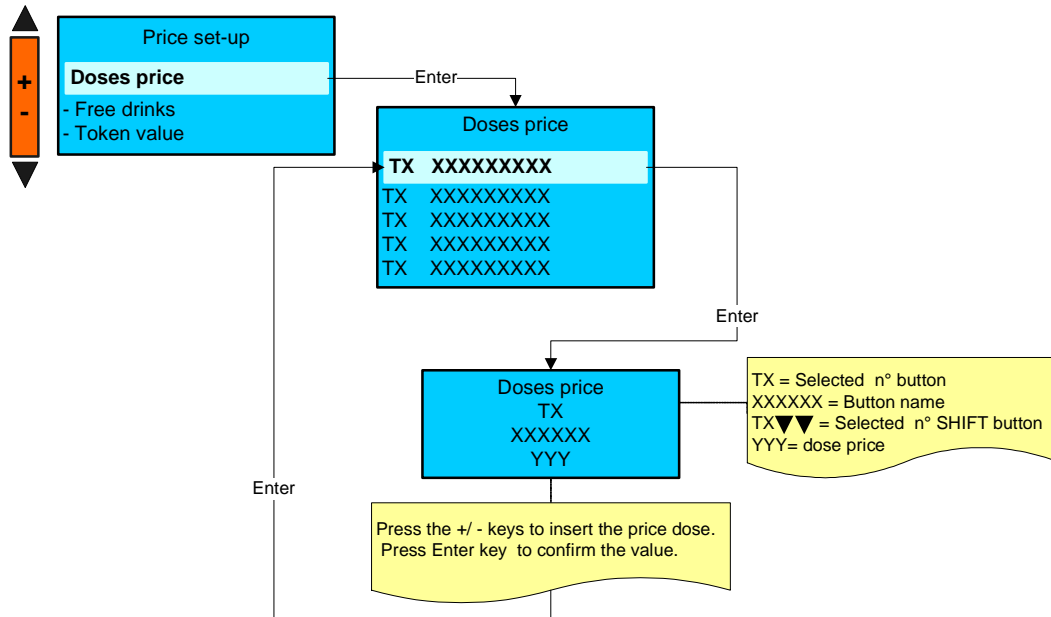

**C2) Free drinks**

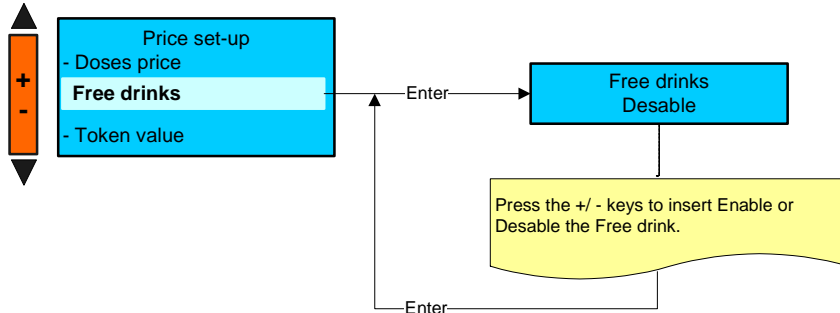

**C3) Token value**

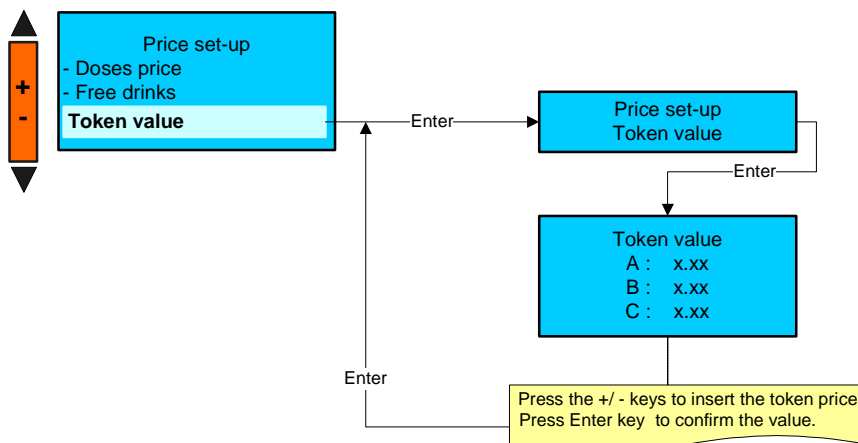

D ) CALIBRATION ( Grinder-Milker )

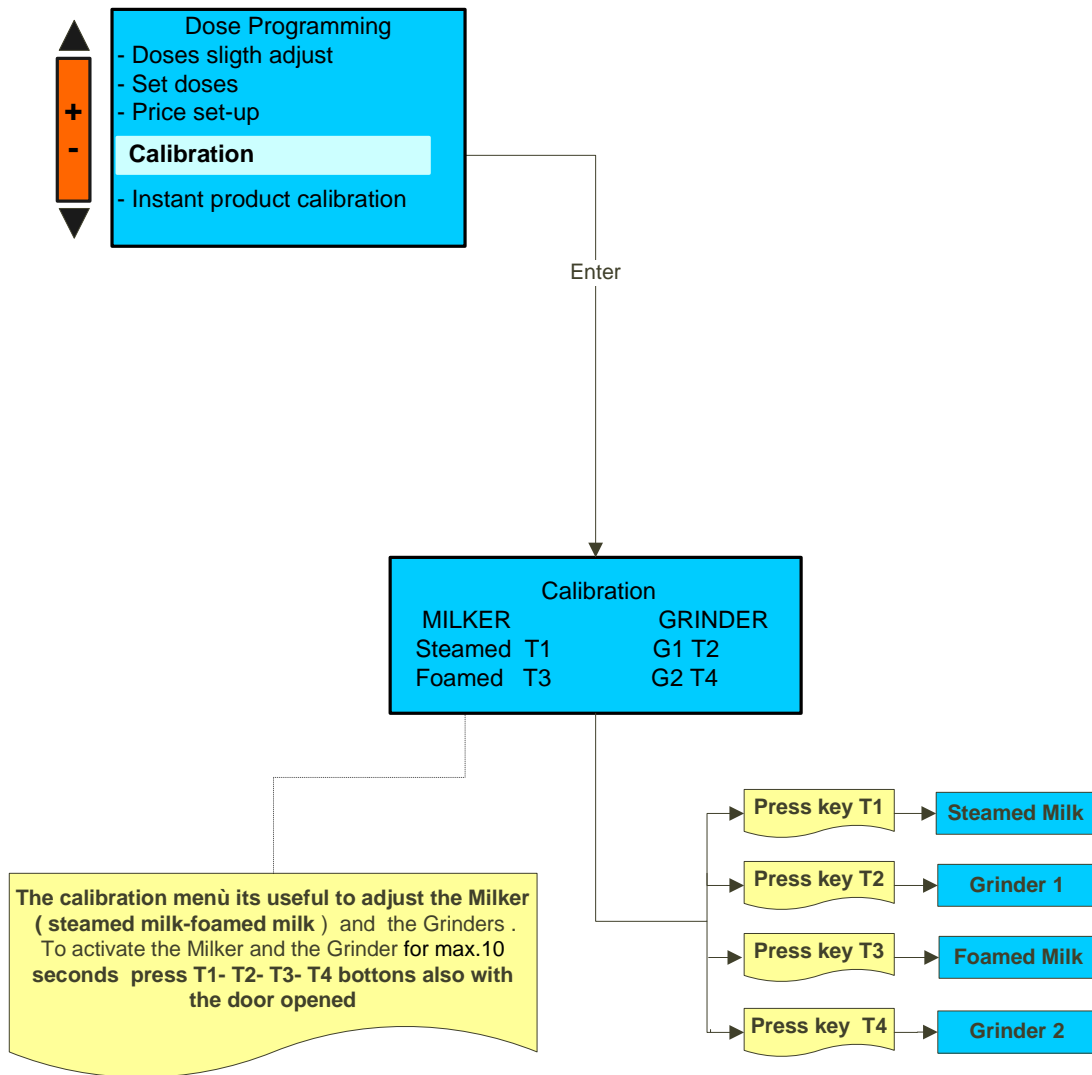

**WARNING:**  
The Milker calibration it is not displayed if there is the milk pump enabled.



**E) INSTANT DISPENSER CALIBRATION**

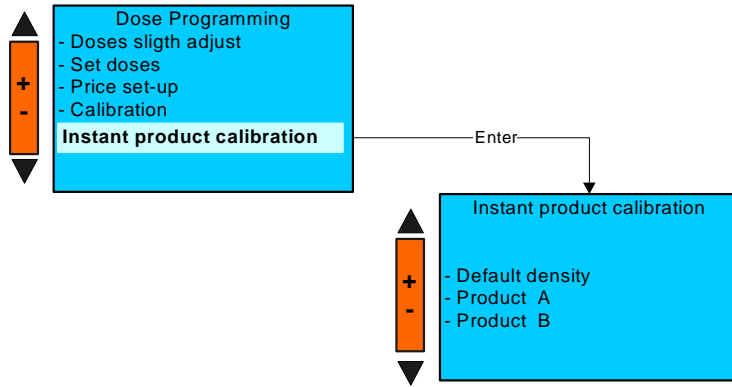

**E1) Default density**

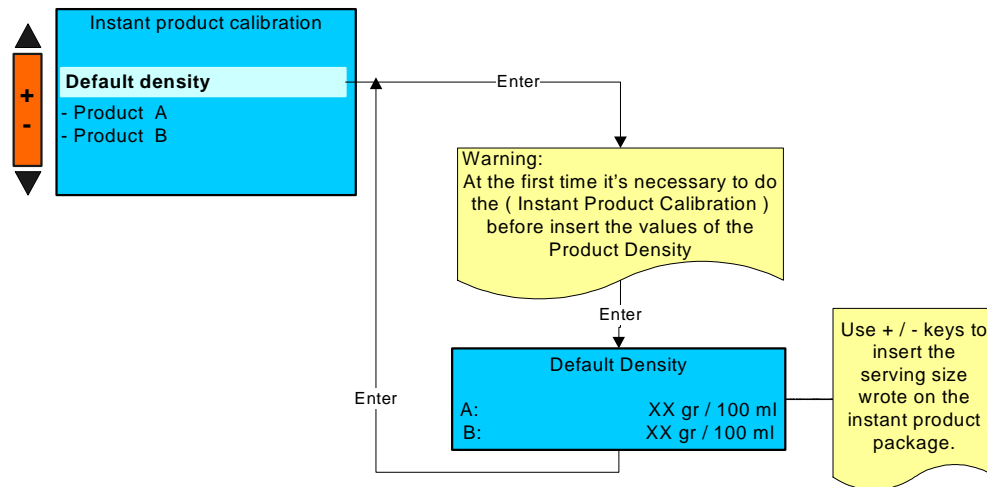

**E2) Product A**

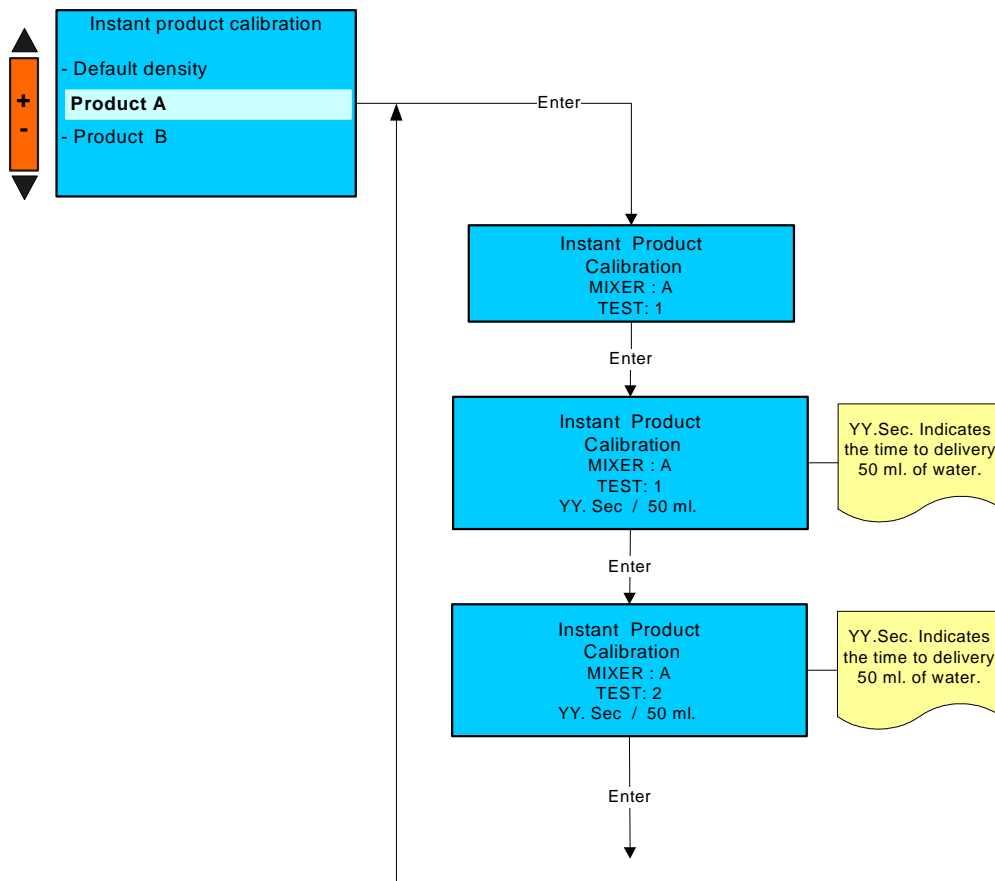

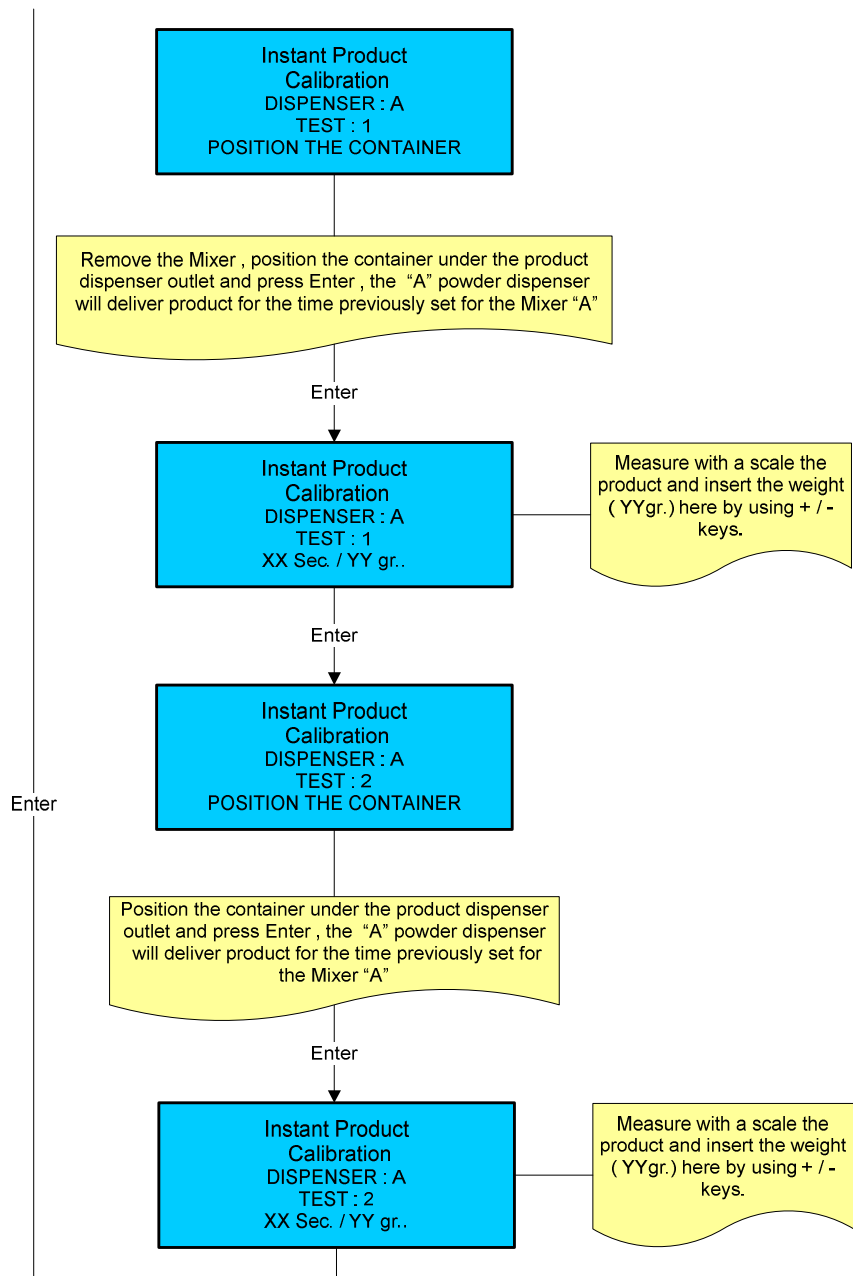

### E3) Product B

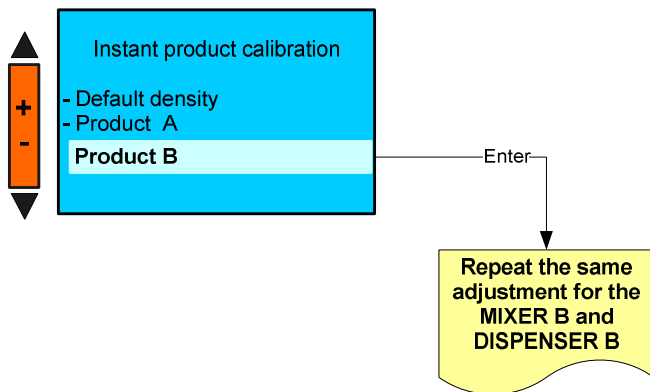

## SYSTEM MANAGER

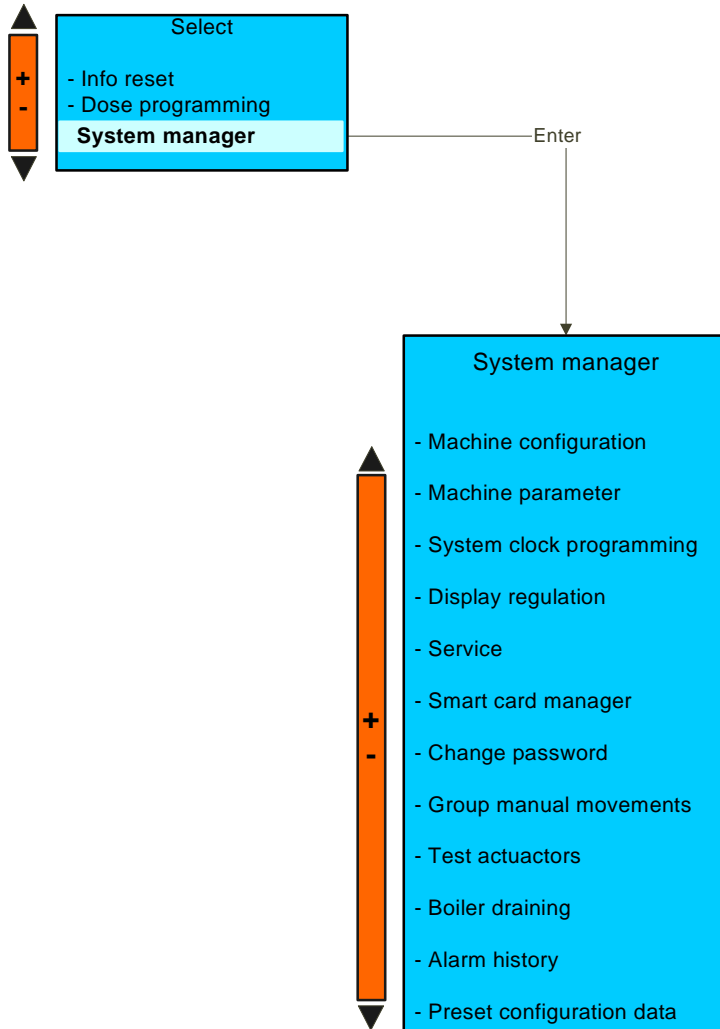

Press the key N°7 (Enter) to confirm entering the desired environment.  
Press the key N° 8 (Esc) to exit.

# MACHINE CONFIGURATION

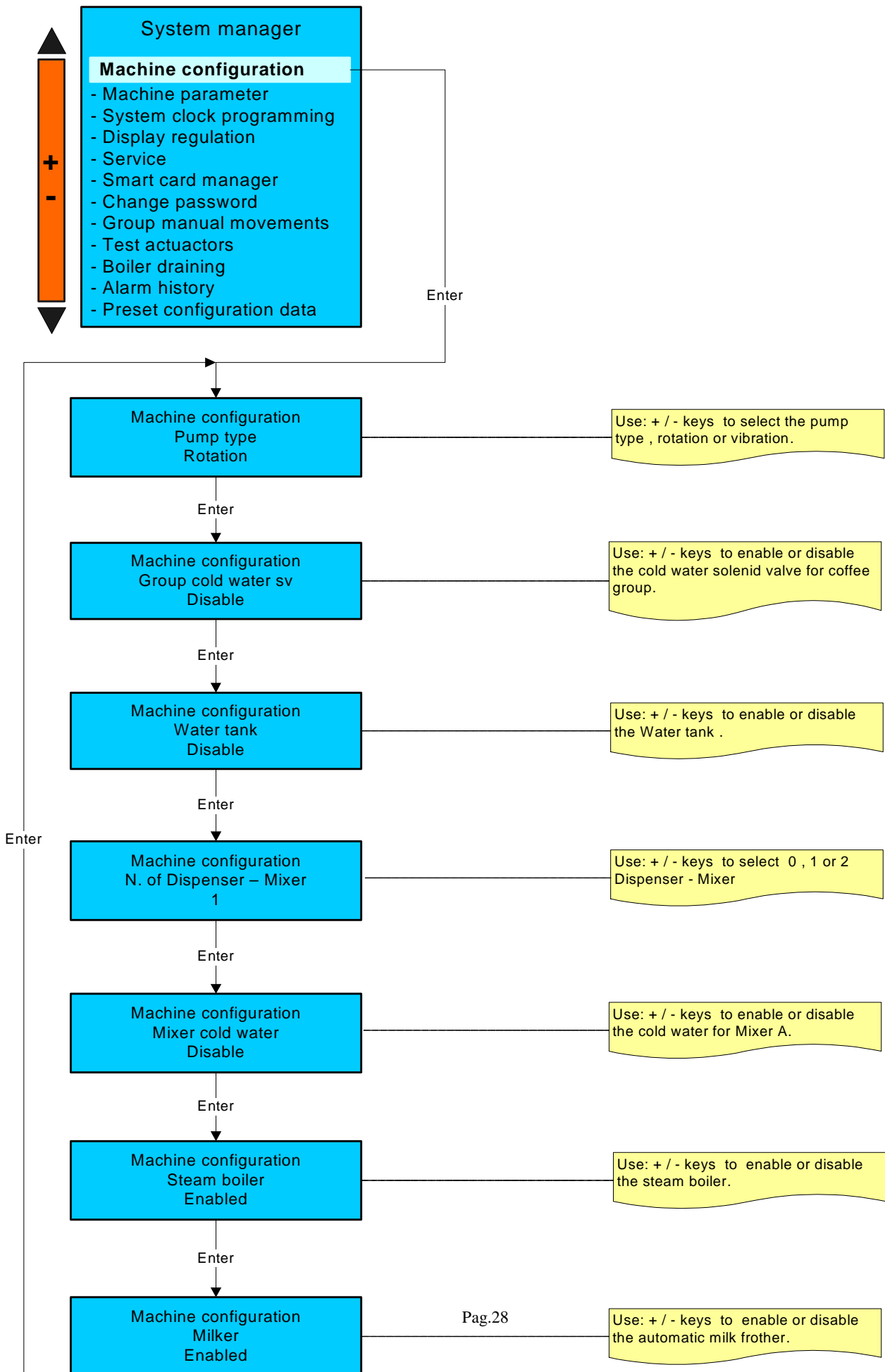

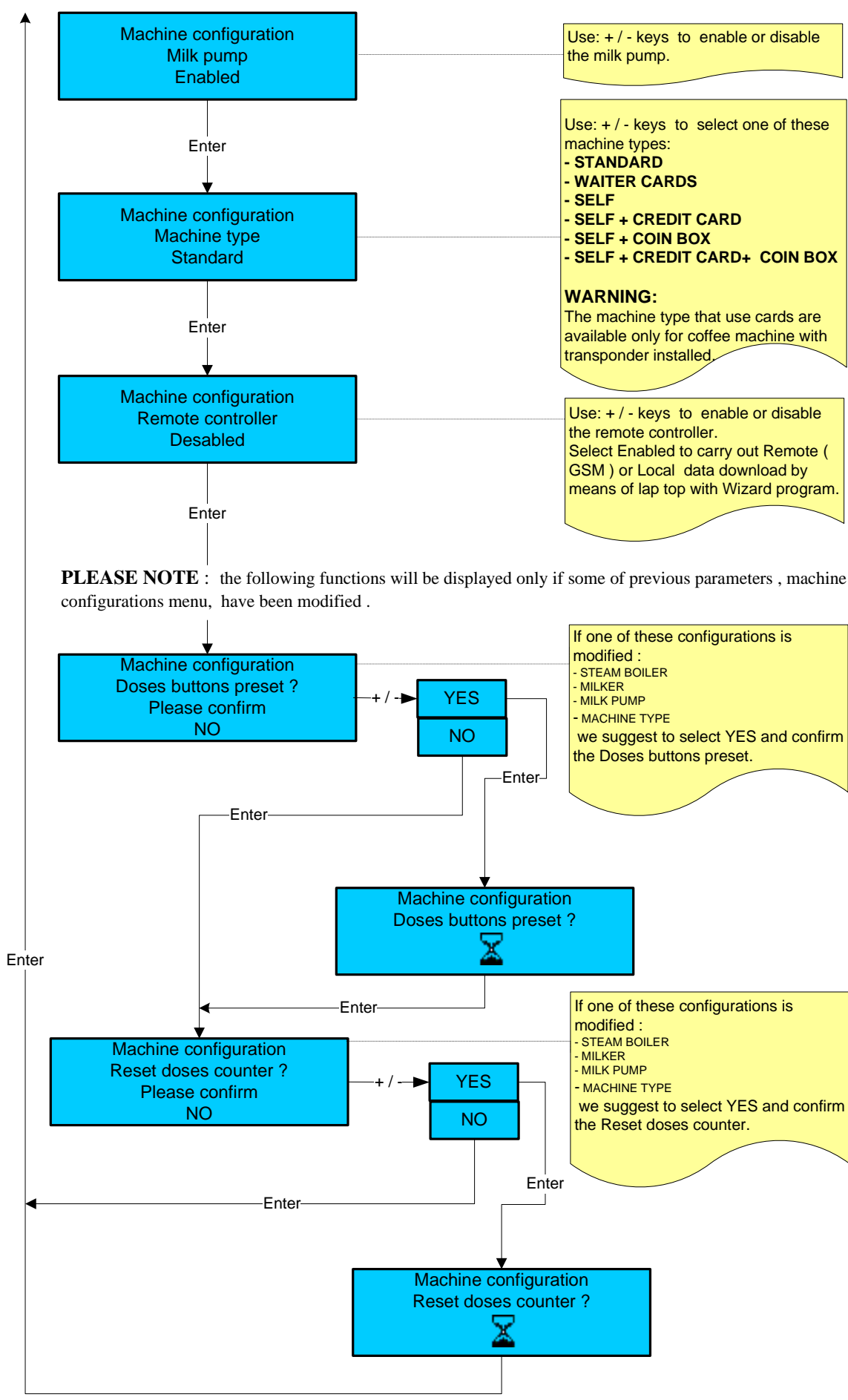

# MACHINE PARAMETERS

**PLEASE NOTE :**  
 some of the following parameters may not be displayed depending to the machine configuration previously programmed.

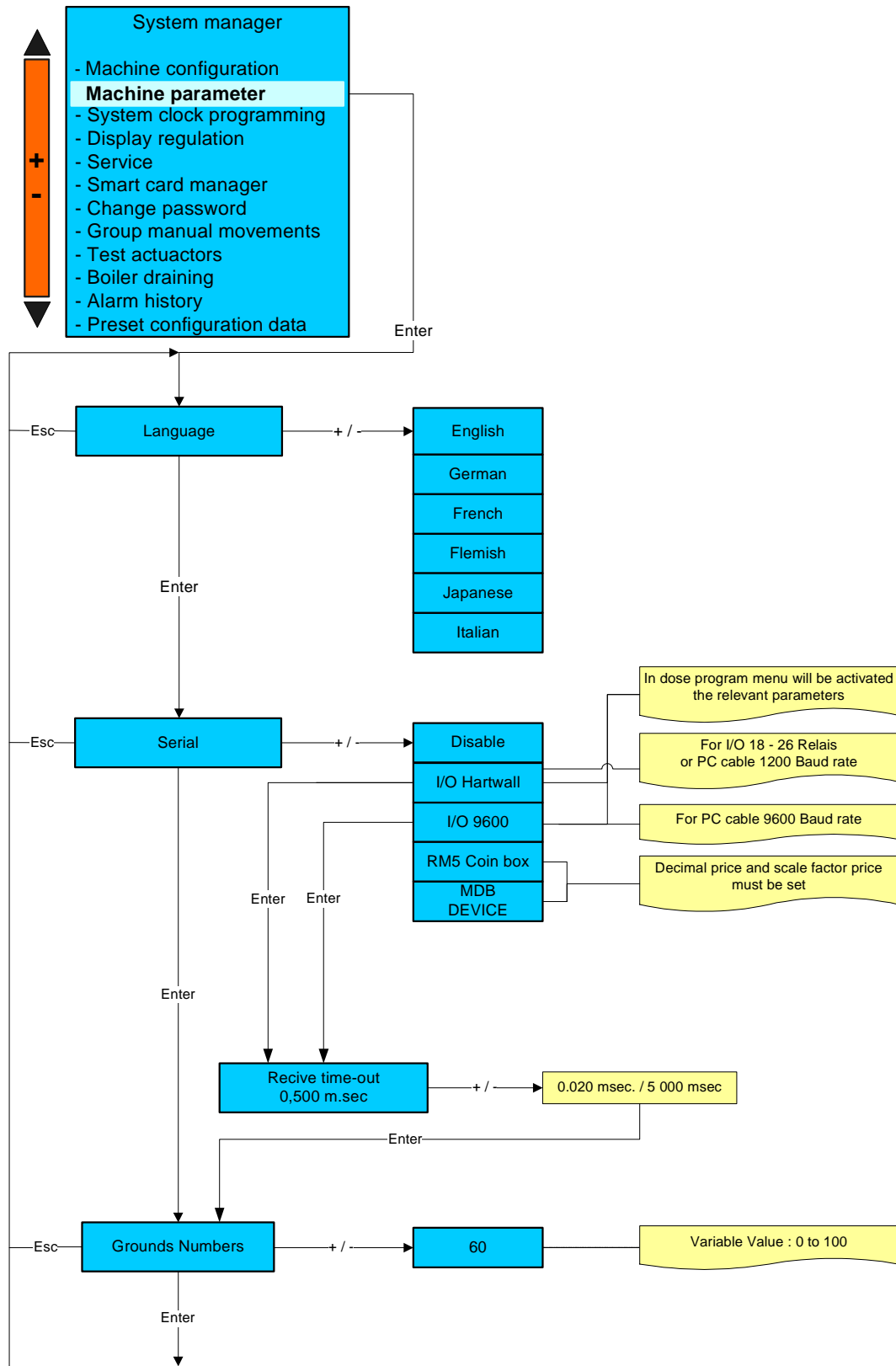

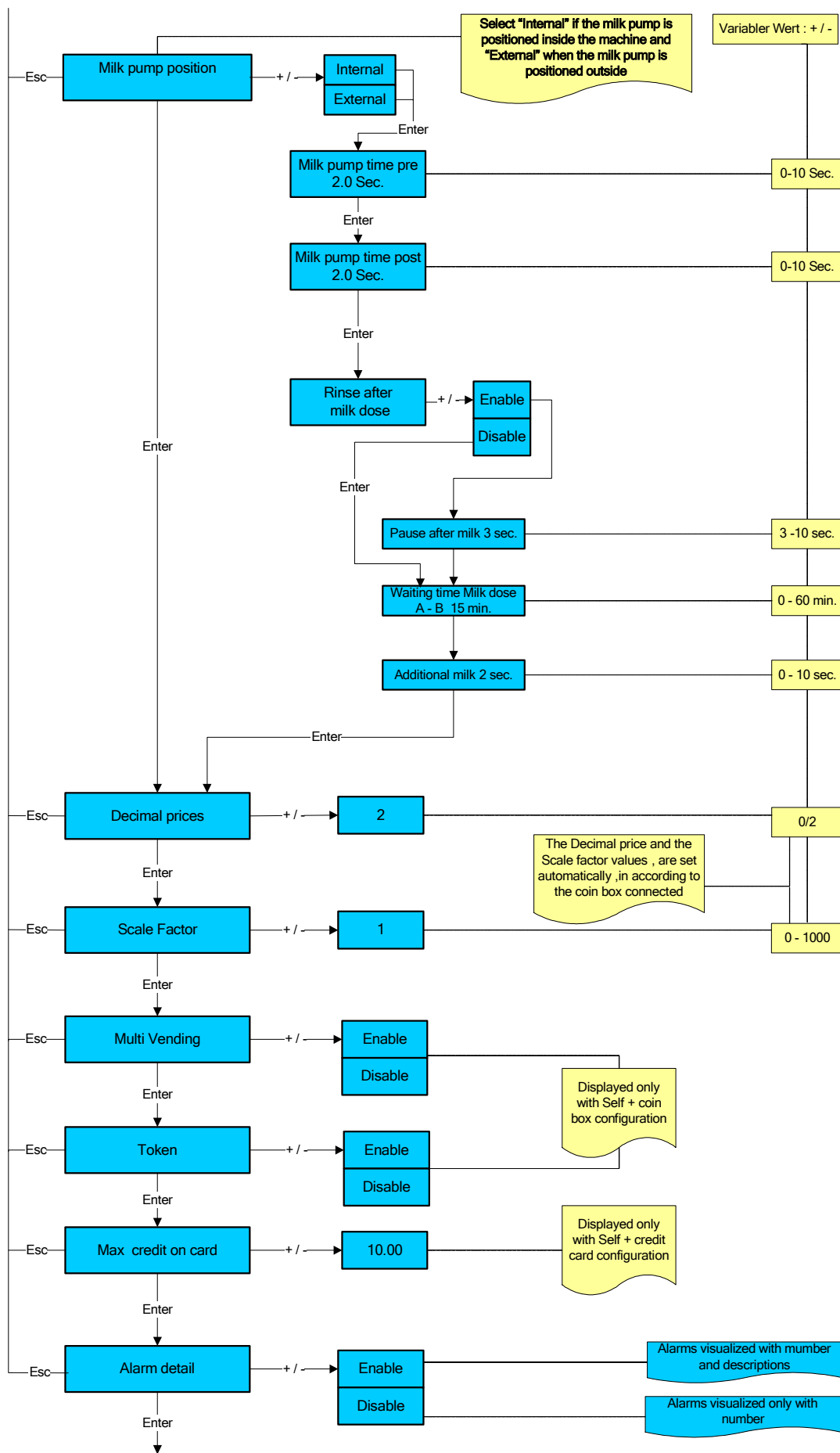

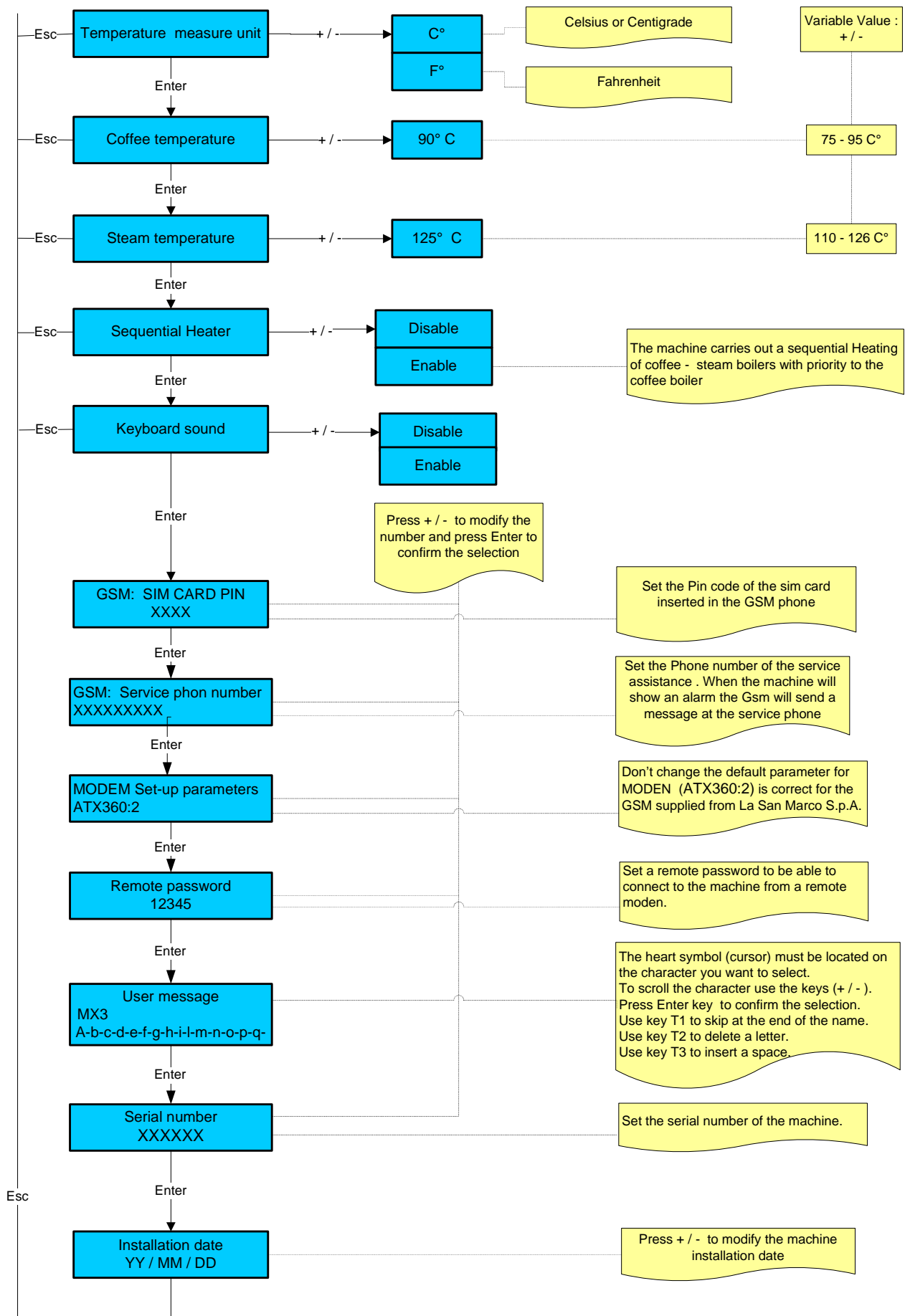

Please note: for machines without GSM it is possible to carry out a Local data download by setting the Serial number and the Remote password only. ( For more information see the Wizard manual ).



# SYSTEM CLOCK SET-UP

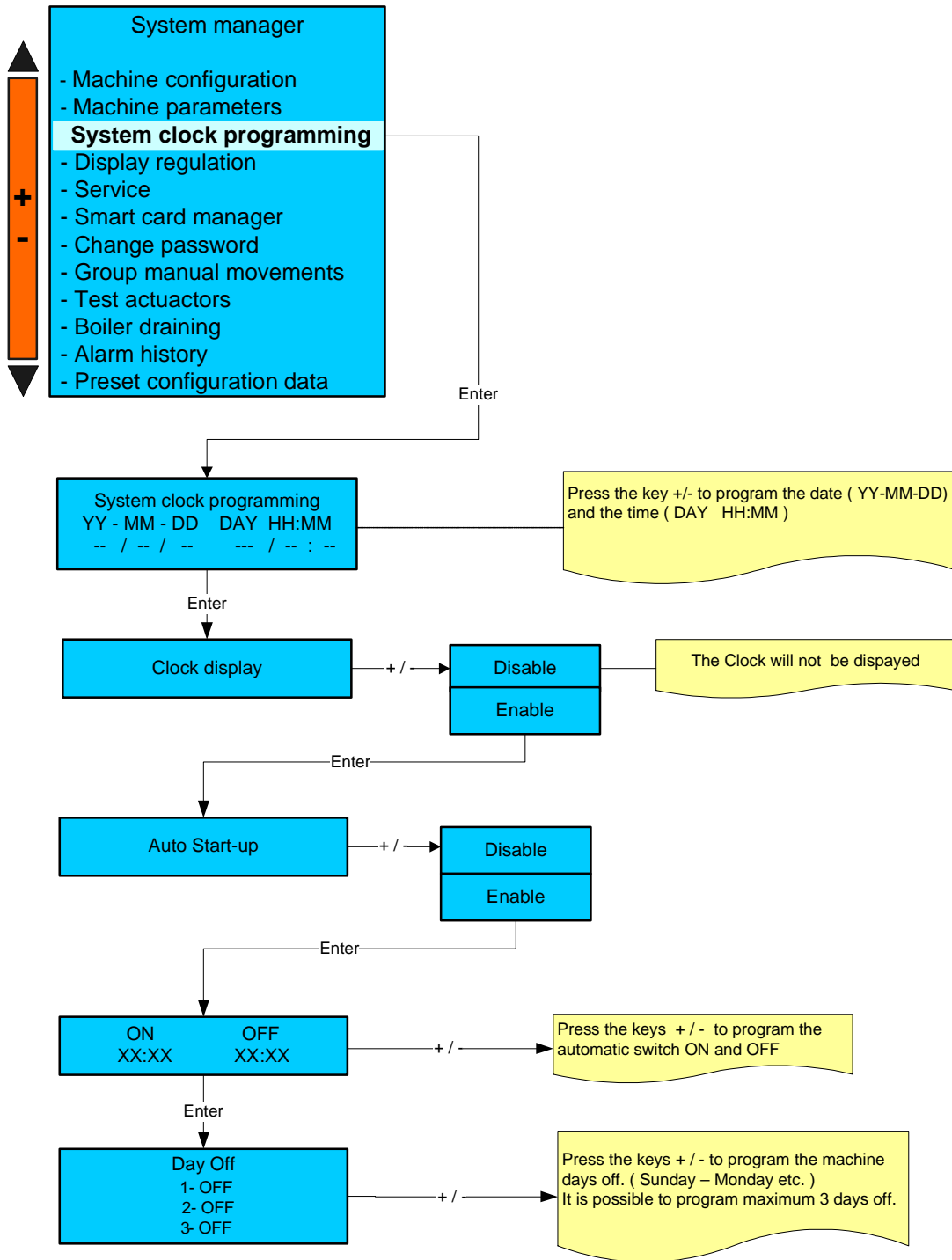

## DISPLAY REGULATION

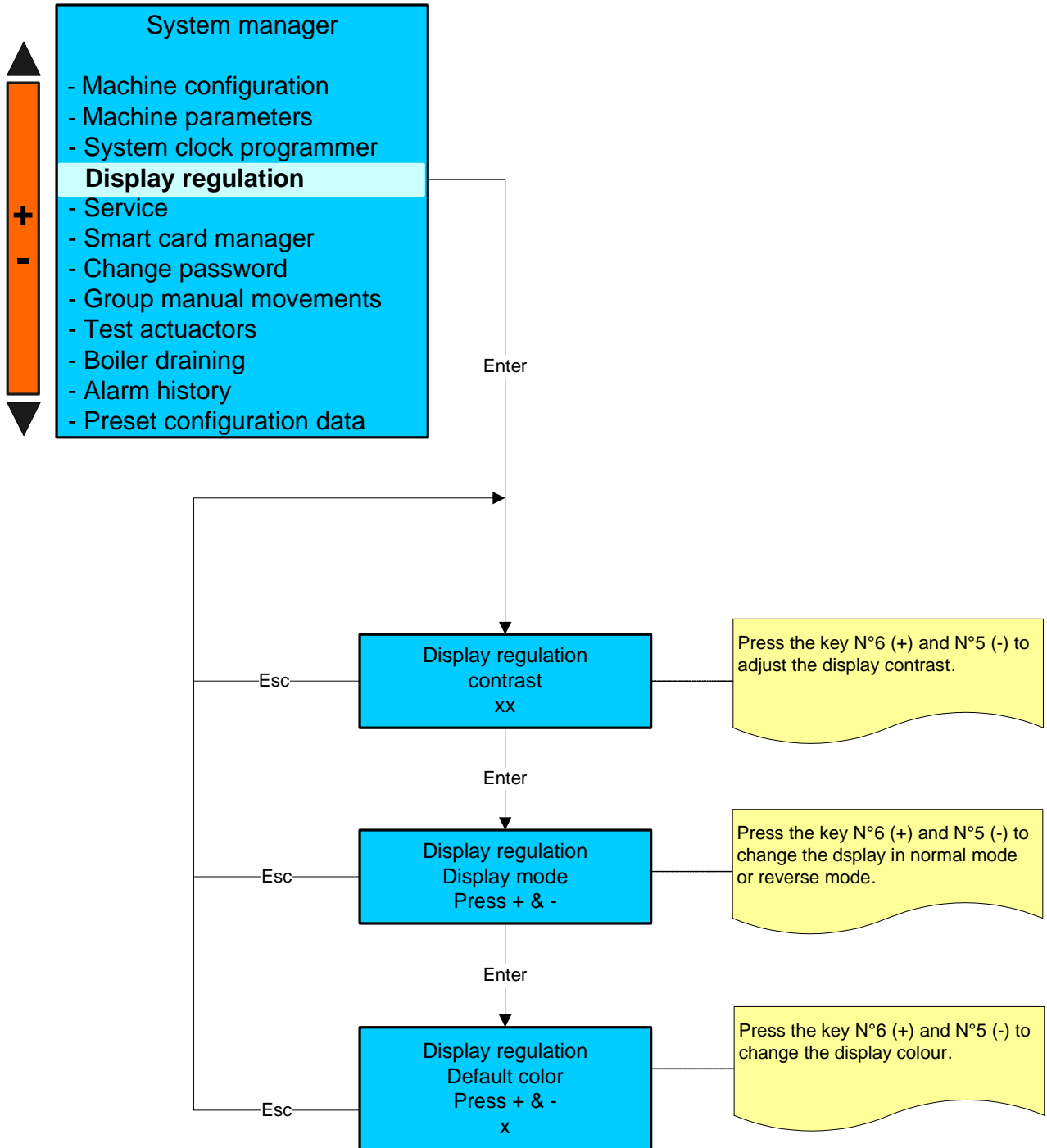

**SERVICE**

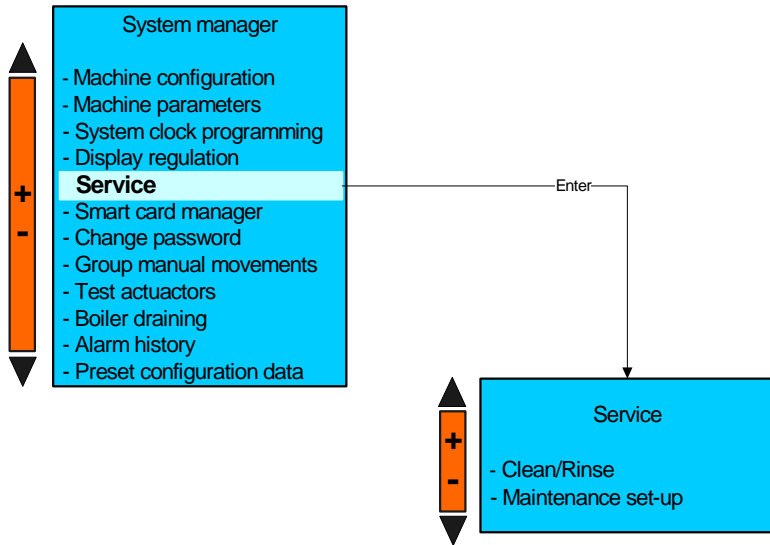

**Clean rinse**

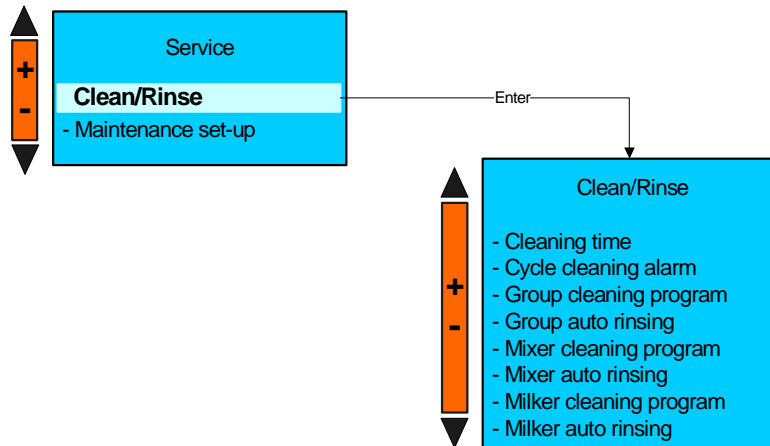

**Cleaning time**

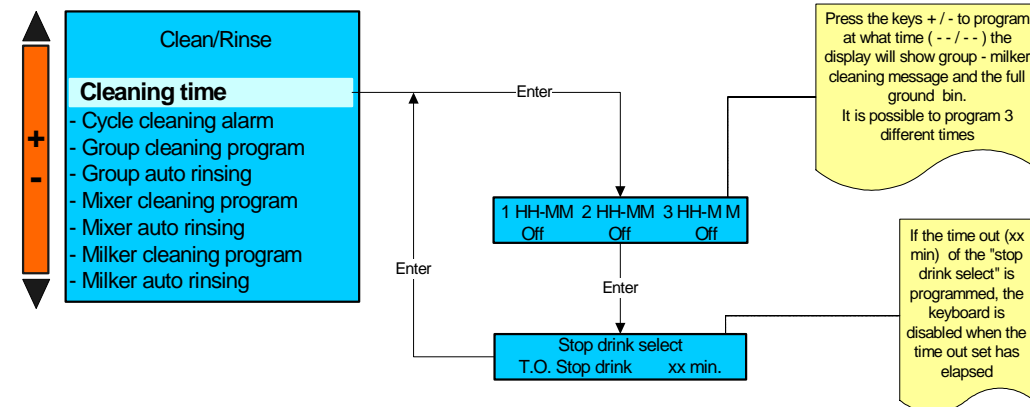

### Cycle cleaning alarm

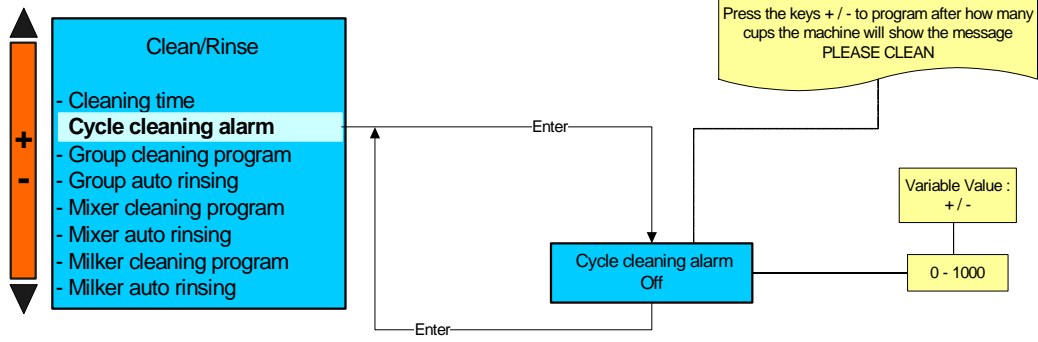

### Group cleaning program

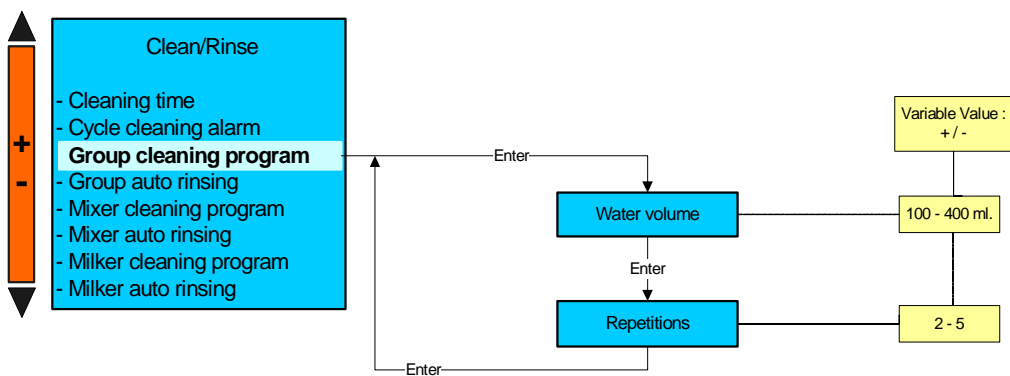

### Group auto rinsing

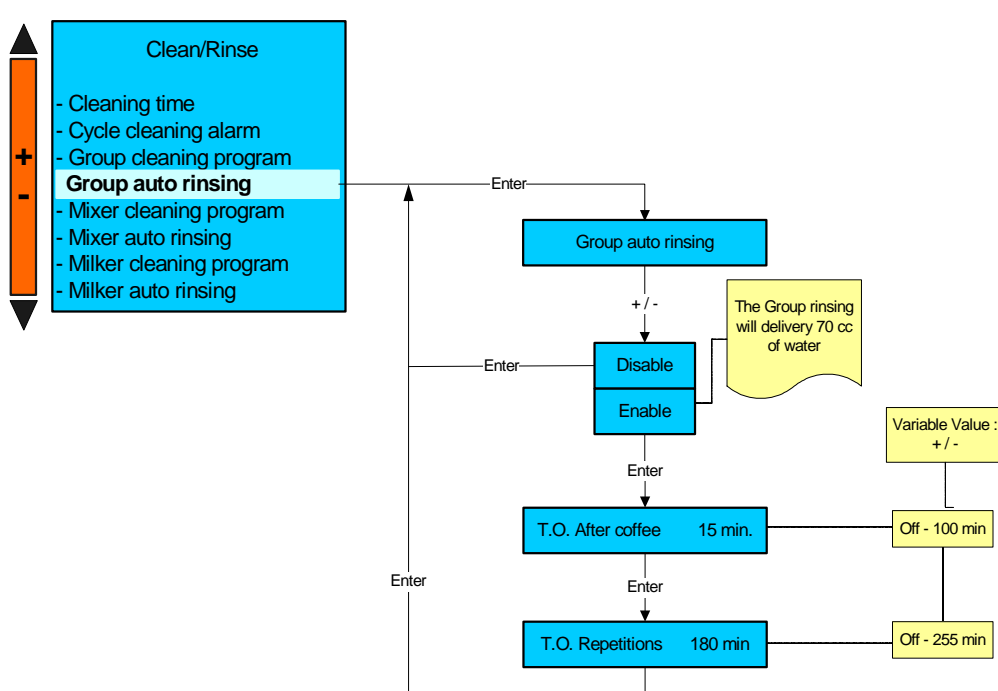

### Mixer cleaning program

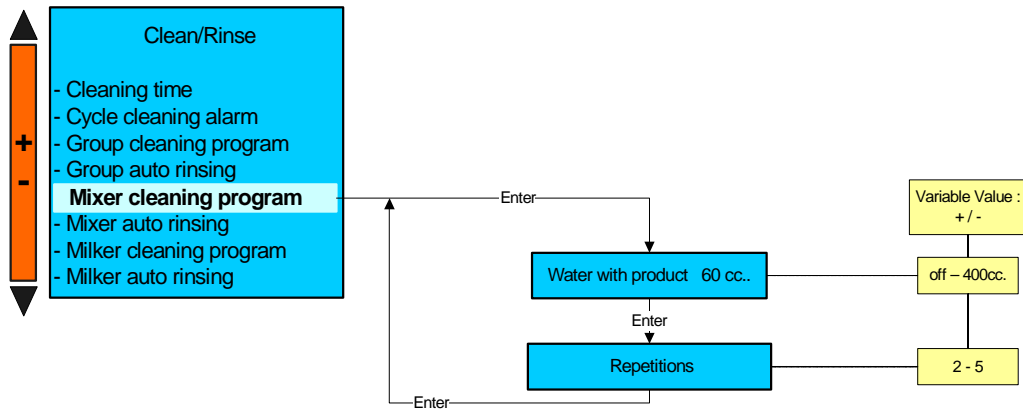

### Mixer auto rinsing

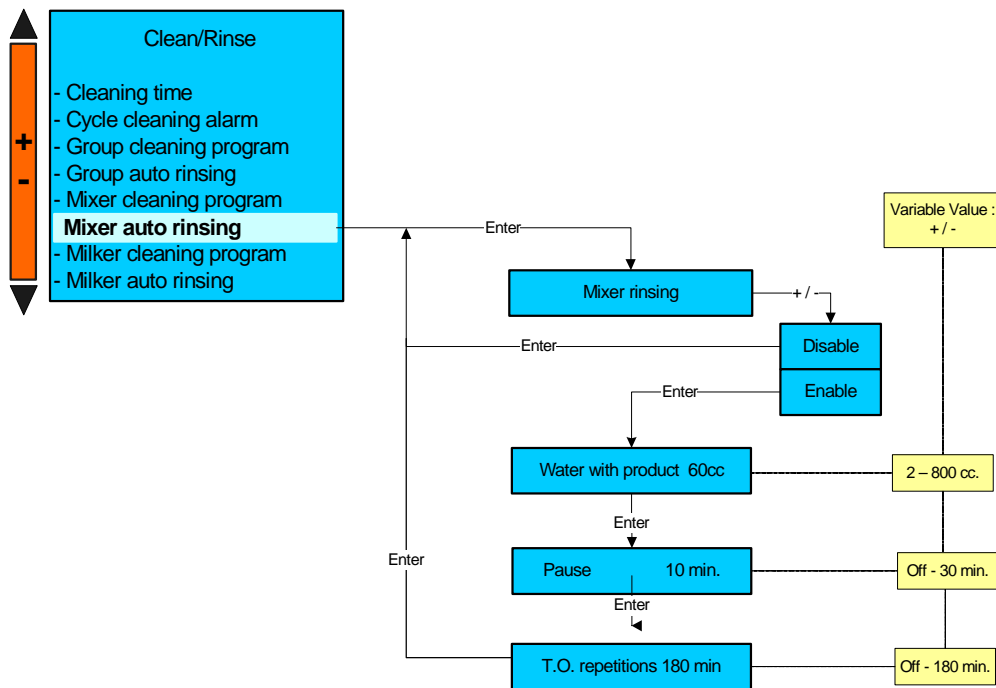

### Milker cleaning program

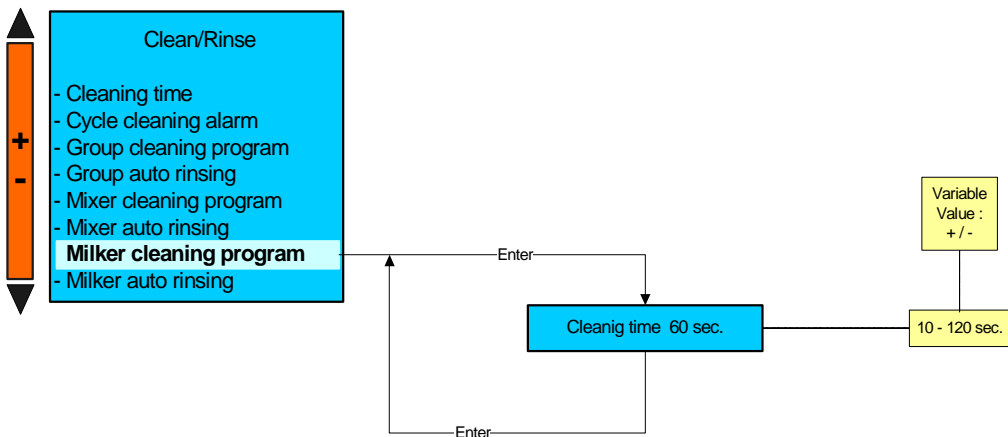

## Milker auto rinsing

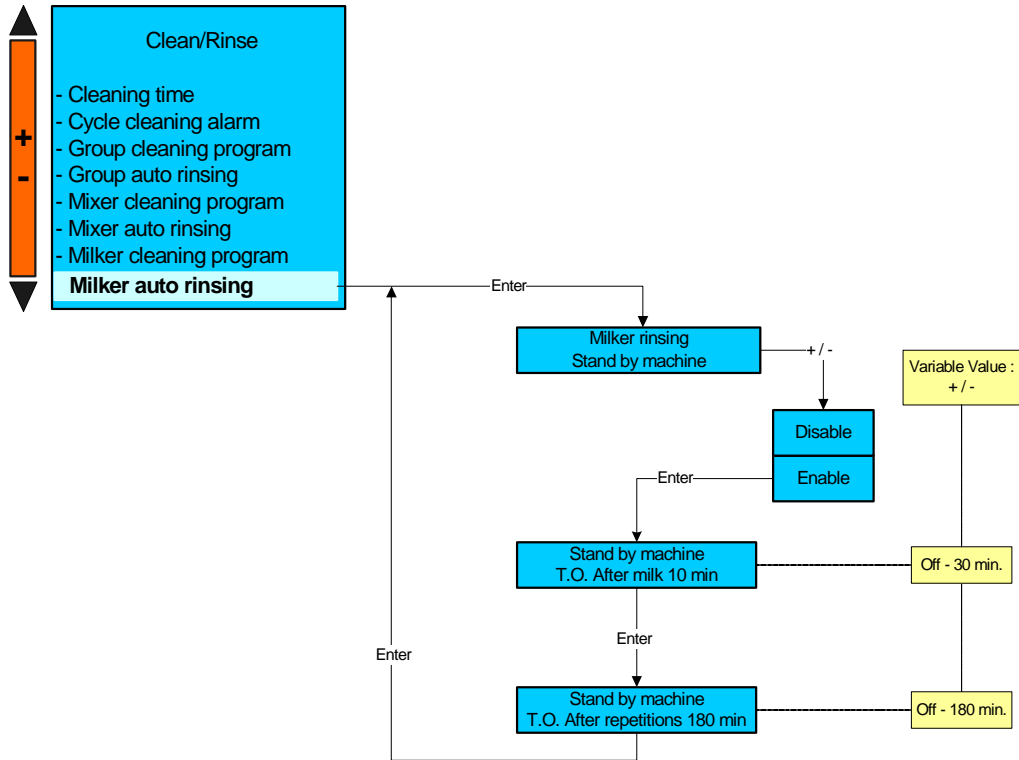

## Maintenance set-up

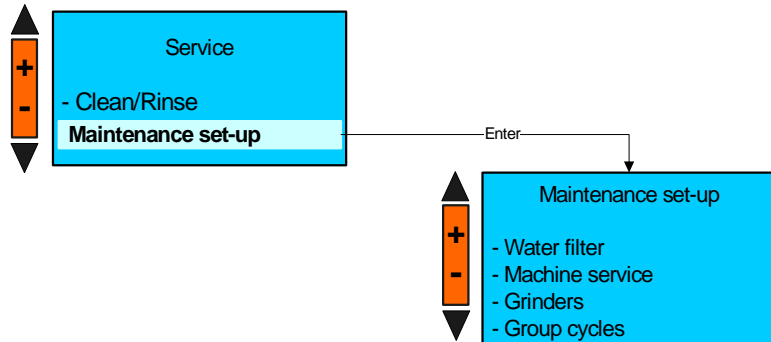

## Water filter

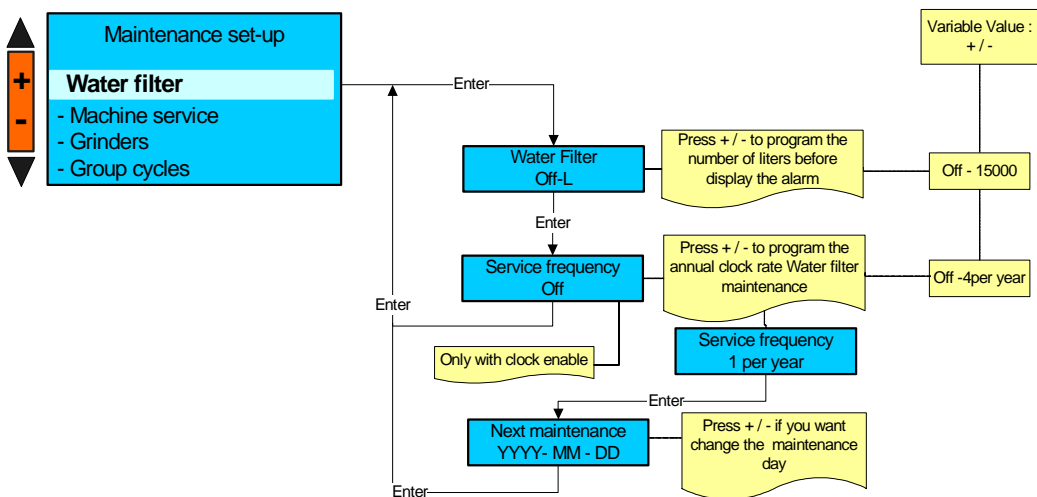

## Machine service

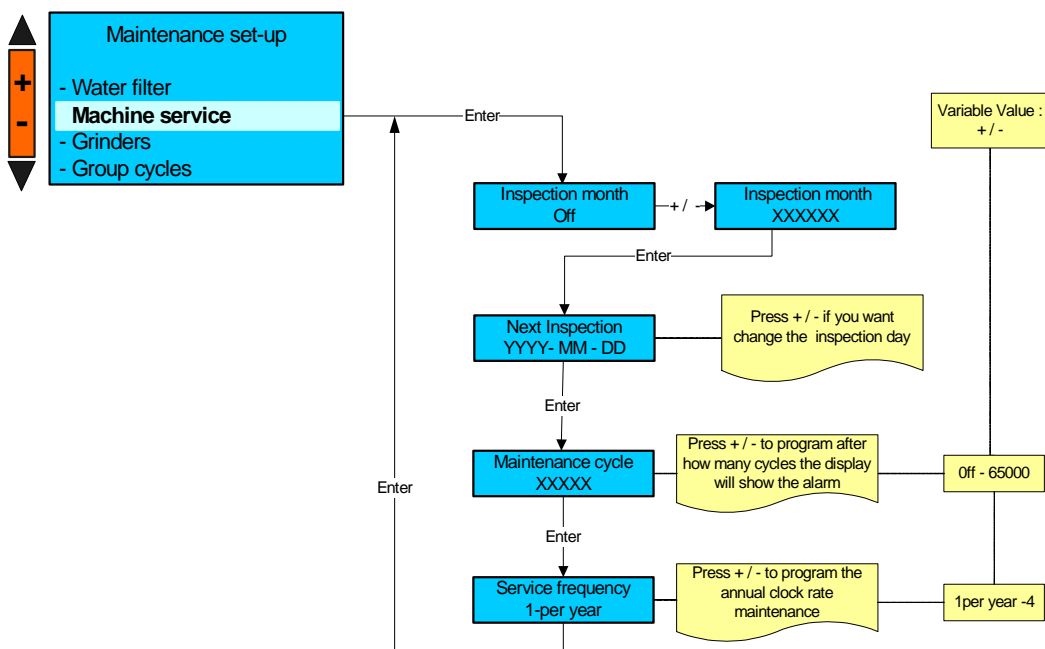

## Grinders

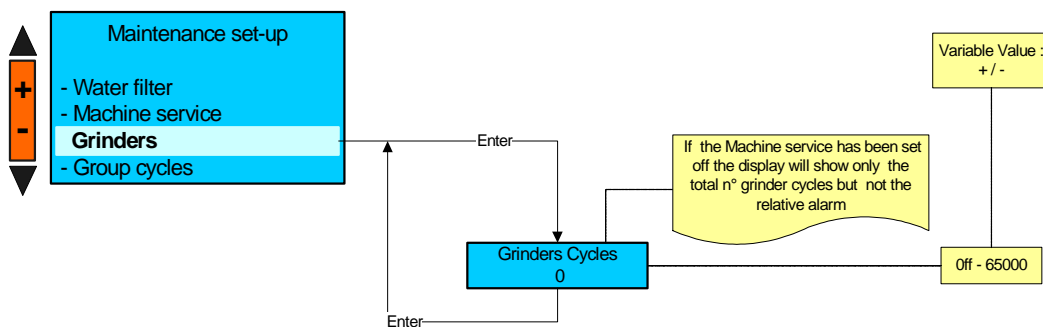

## Group cycles

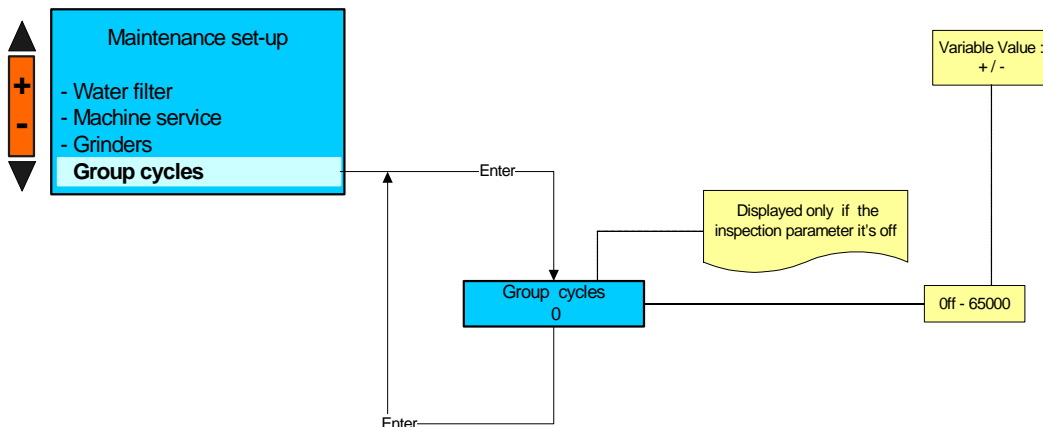

**SMART CARD MANAGER**

PLEASE NOTE:

A -THE SMART CARD MANAGER IS DISPLAYED ONLY FOR COFFEE MACHINE WITH TRANSPONDER INSTALLED.

B -TO CREATE A NEW CARD (TECHNICIAN – SERVICE – OWNER – ROASTER AND WAITER ) ITS NECESSARY USE AN EXTERNAL PC TOOL.

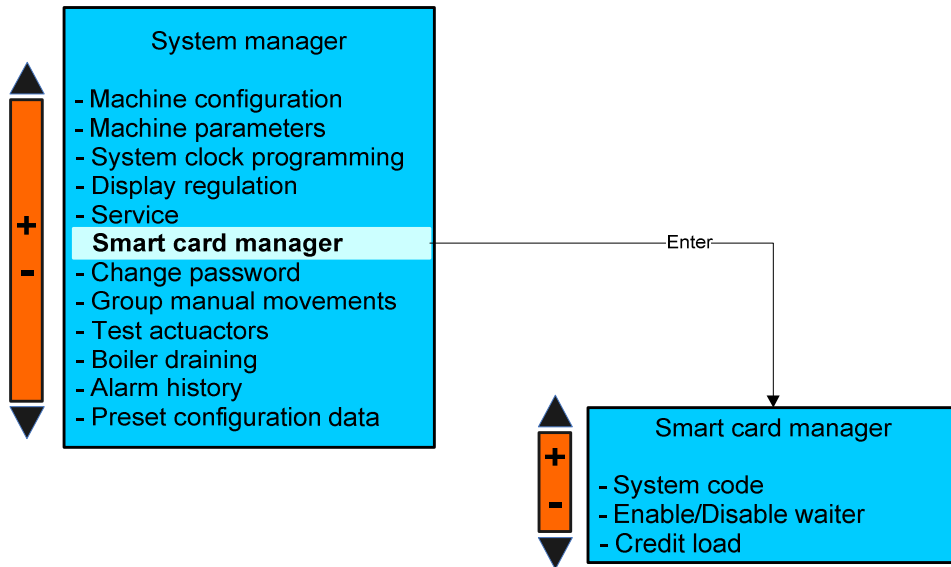

**System code**

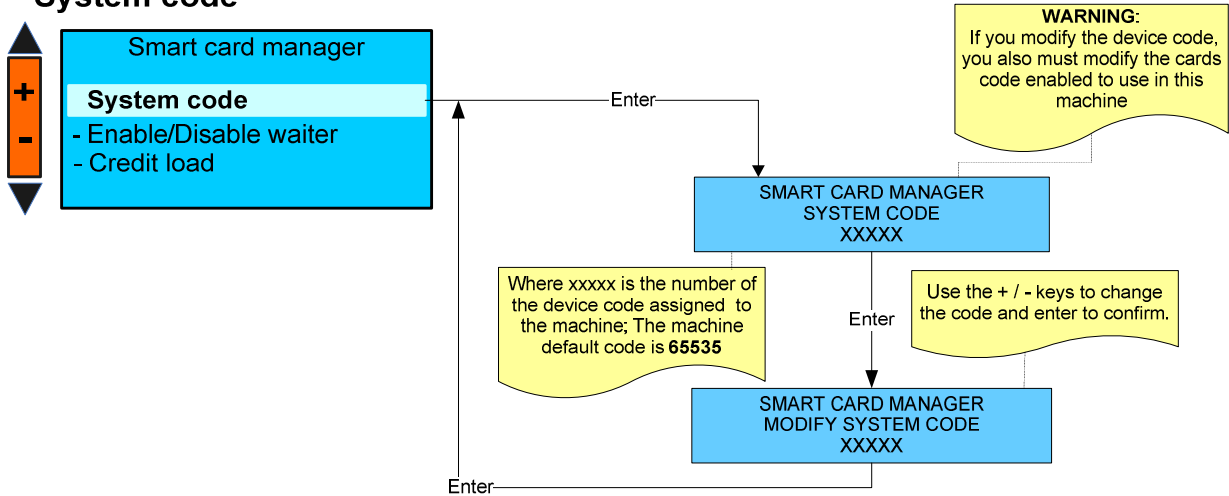

**Enable/Disable waiter**

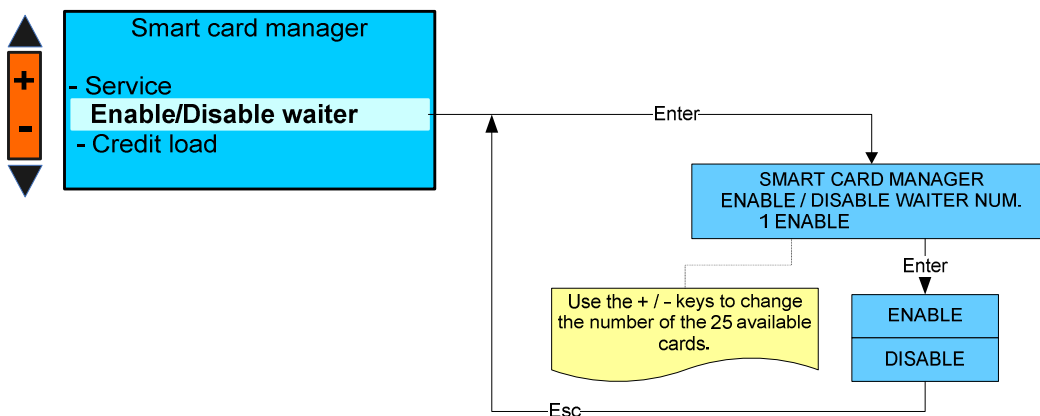



## Credit load

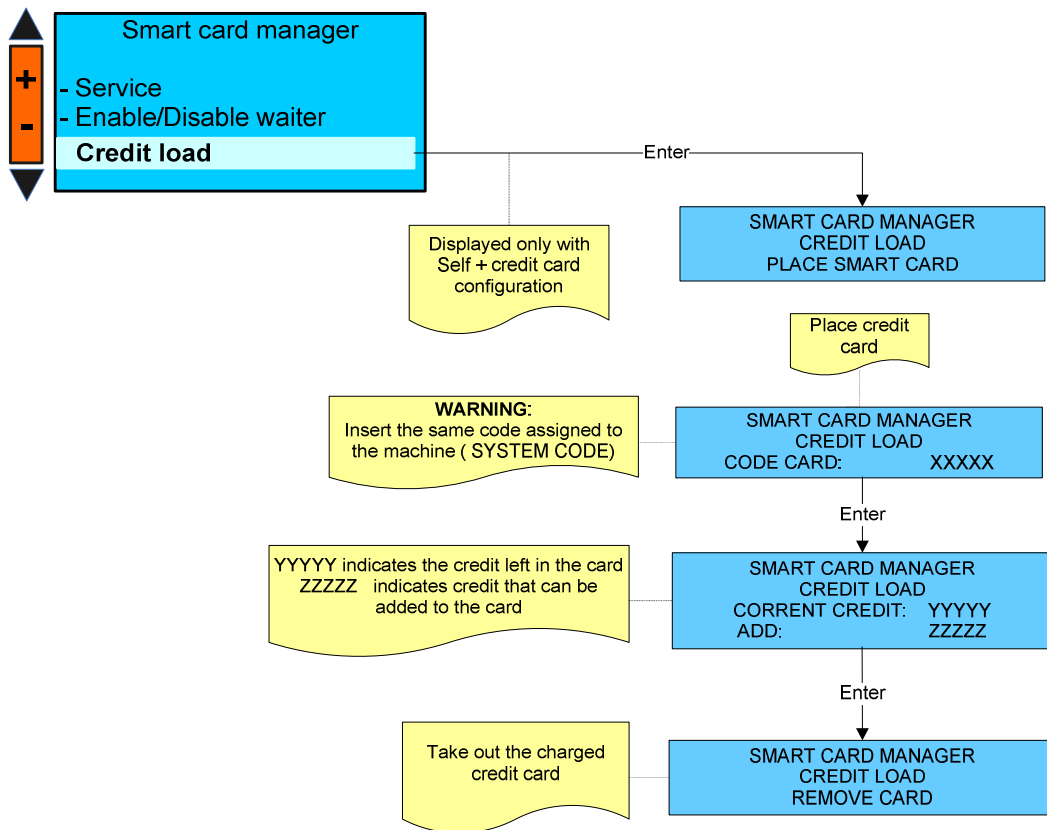

# CHANGE PASSWORD

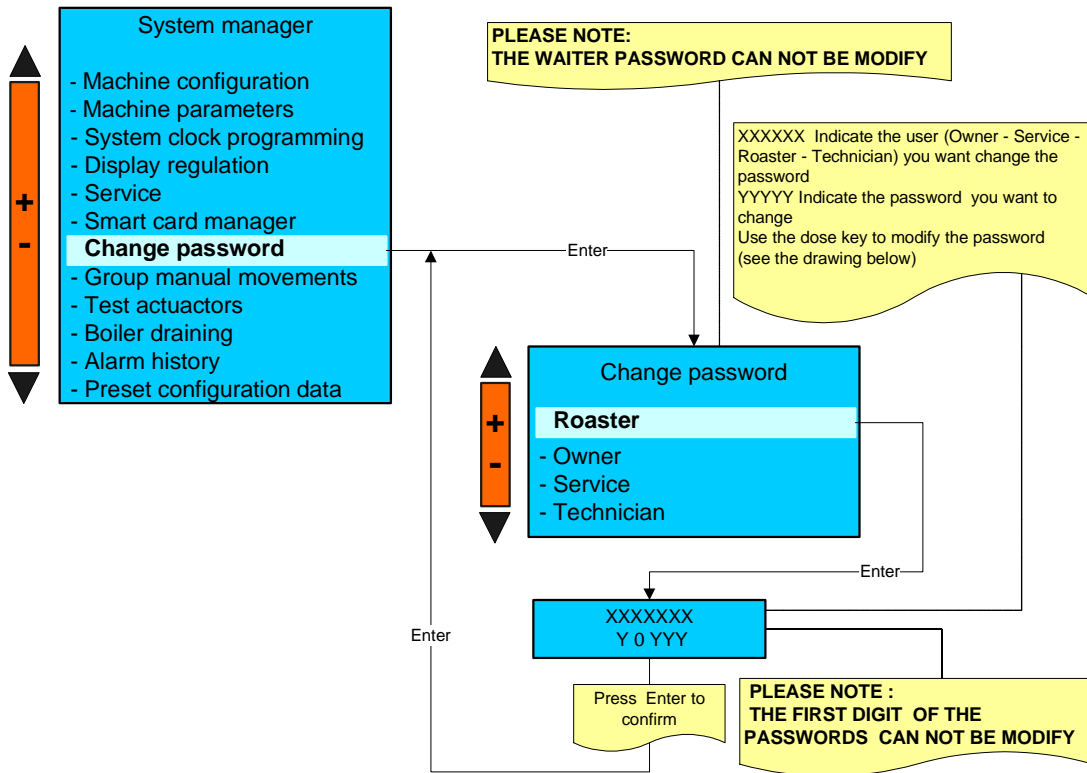

## KEY REFERENCE FOR PASSWORD

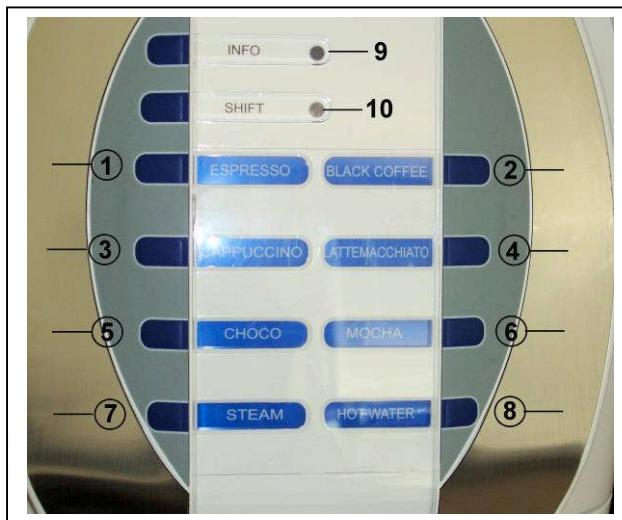

Following Password can be modify					
	Waiter	Roaster	Owner	Service	Technician
<b>Entered Password</b>	<b>Waiter</b>				
	<b>Roaster</b>		X		
	<b>Owner</b>		X	X	
	<b>Service</b>		X	X	X
	<b>Technician</b>		X	X	X

# GROUP MANUAL MOVEMENTS

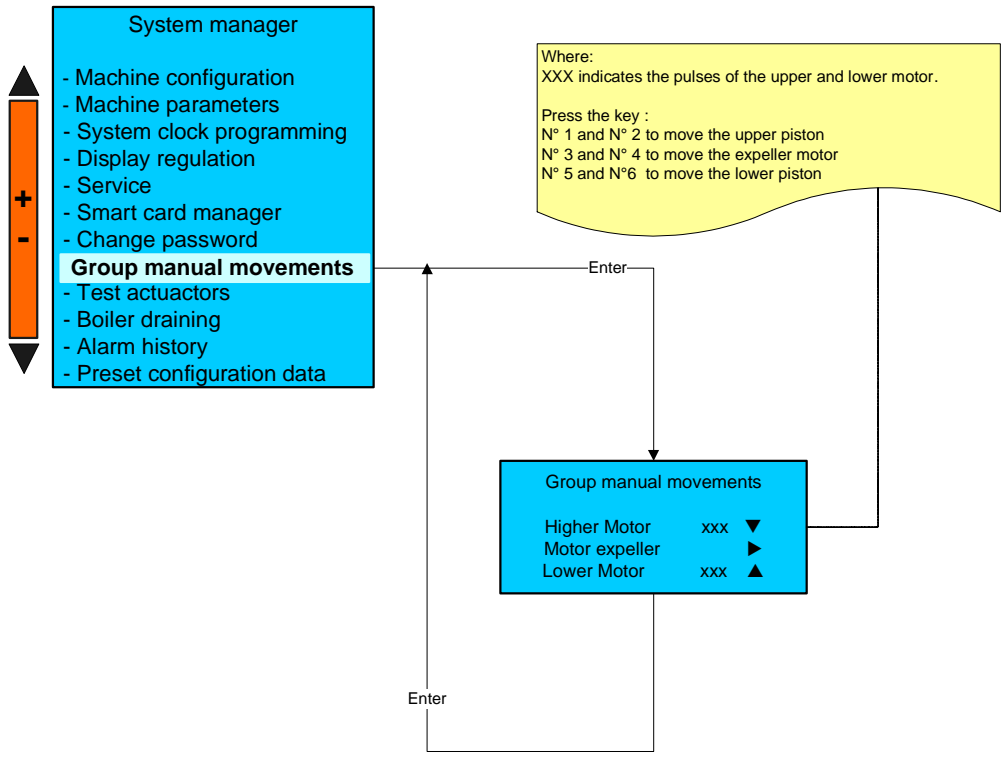

# TEST ACTUATORS

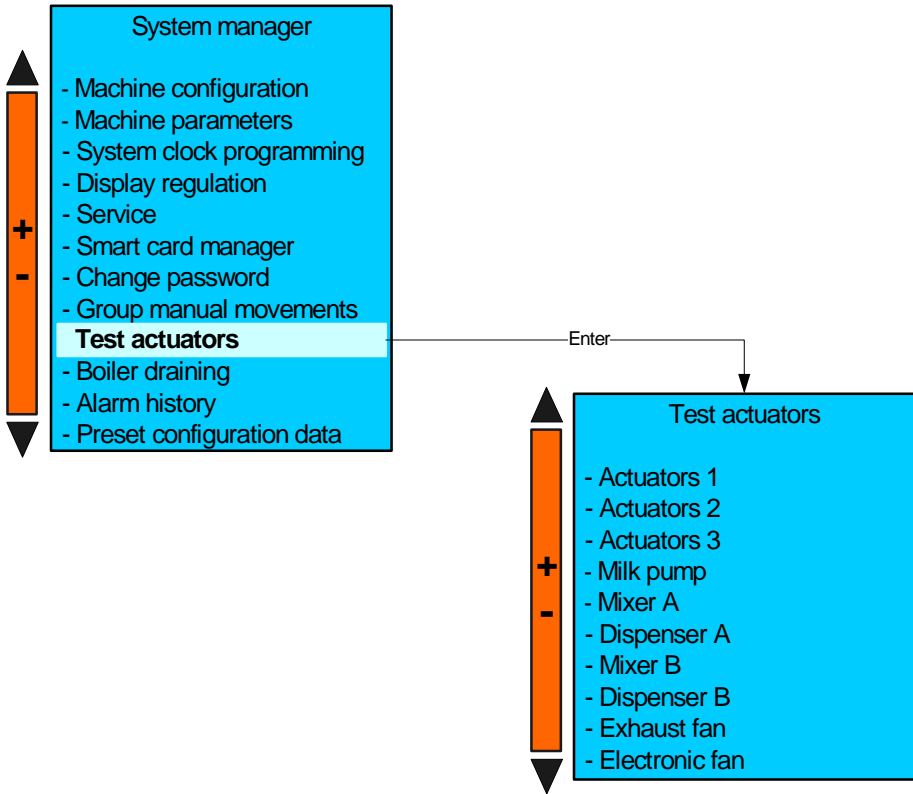

## Actuators 1

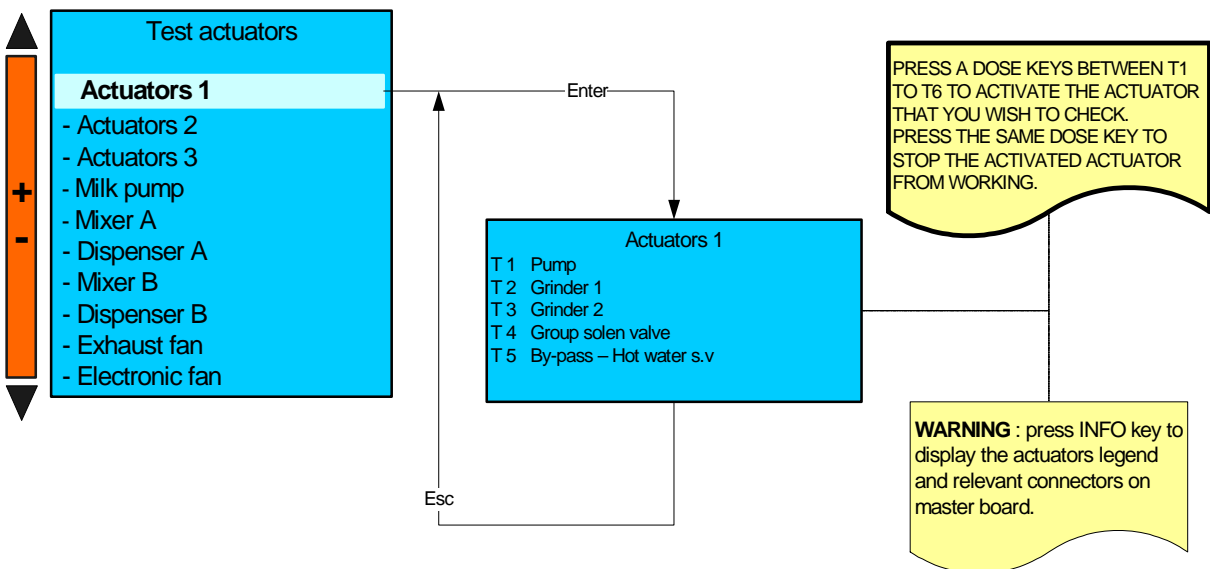

### Actuators 2

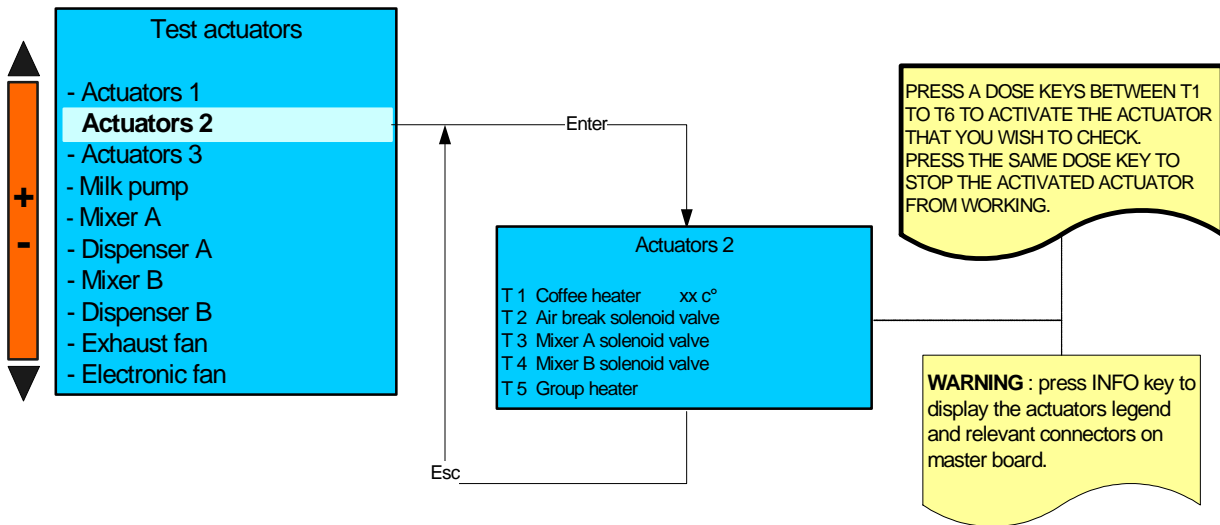

### Actuators 3

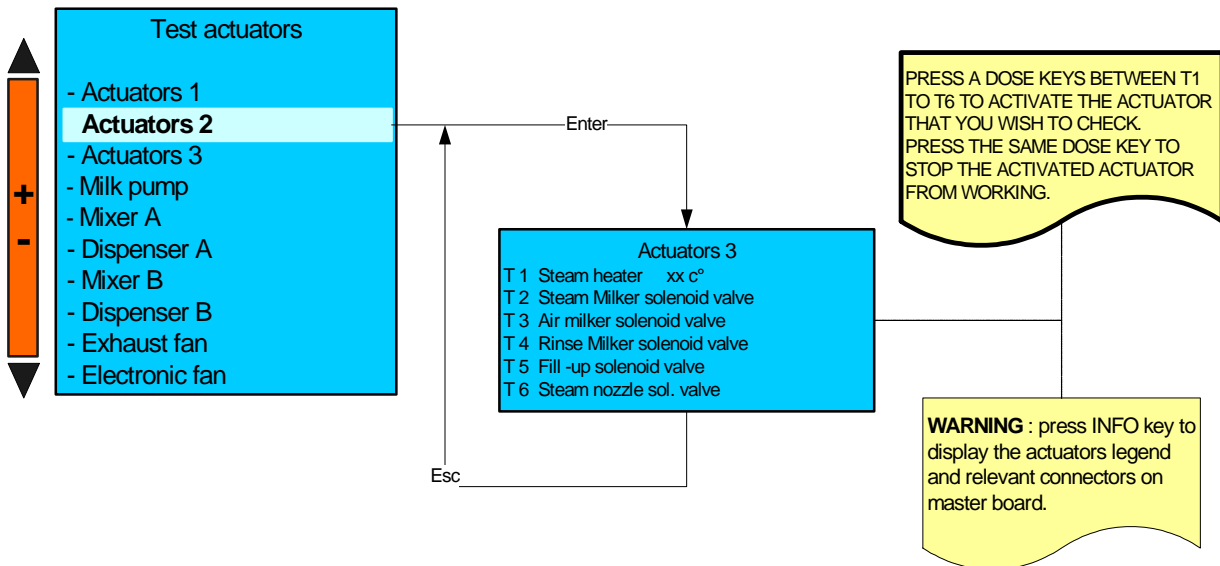

### Milk pump

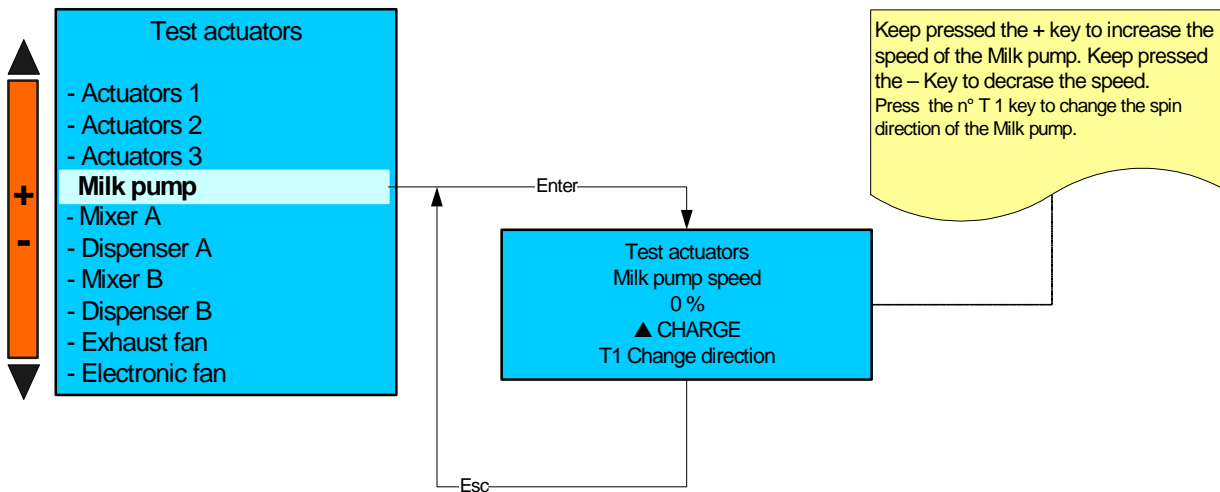

### Mixer A

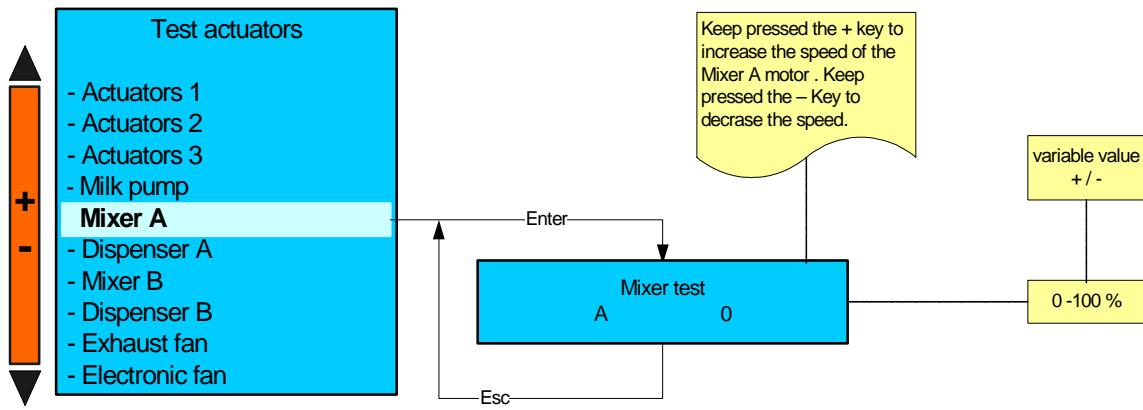

### Dispenser A

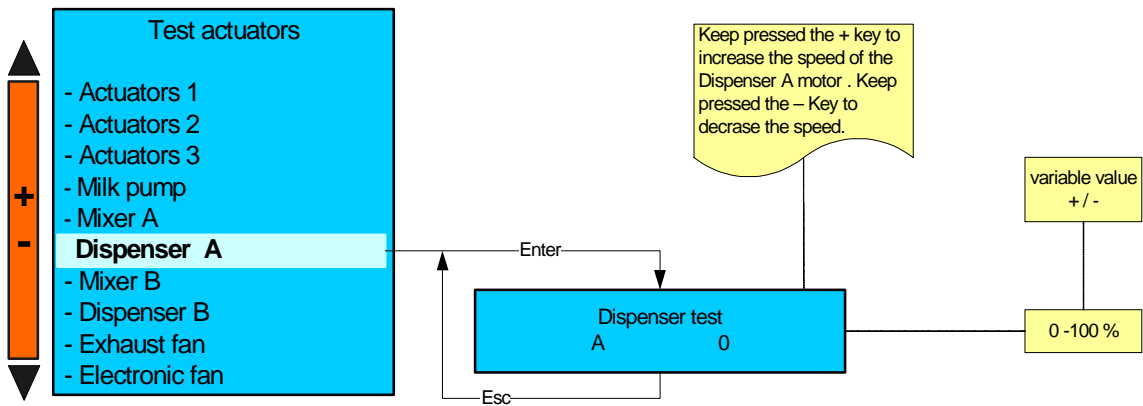

### Mixer B

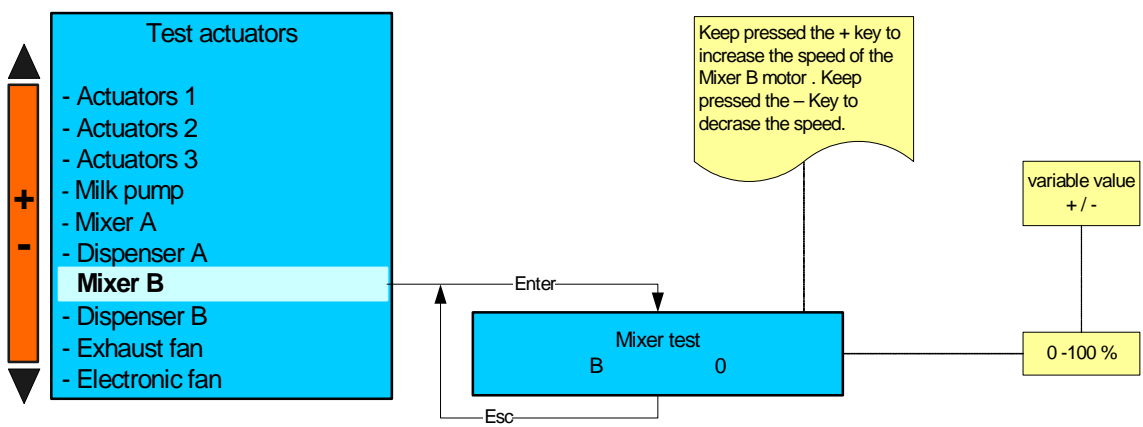

### Dispenser B

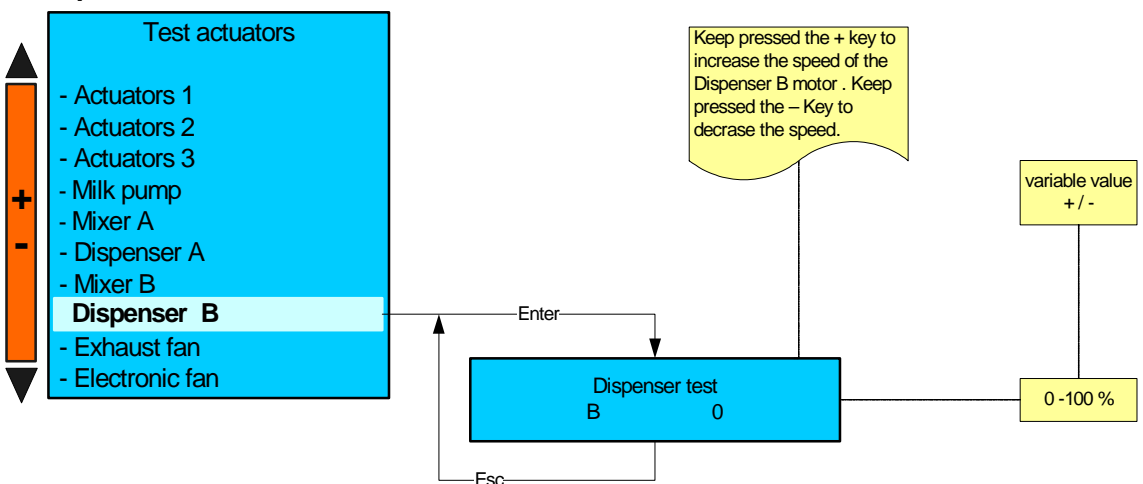

## Exhaust fan

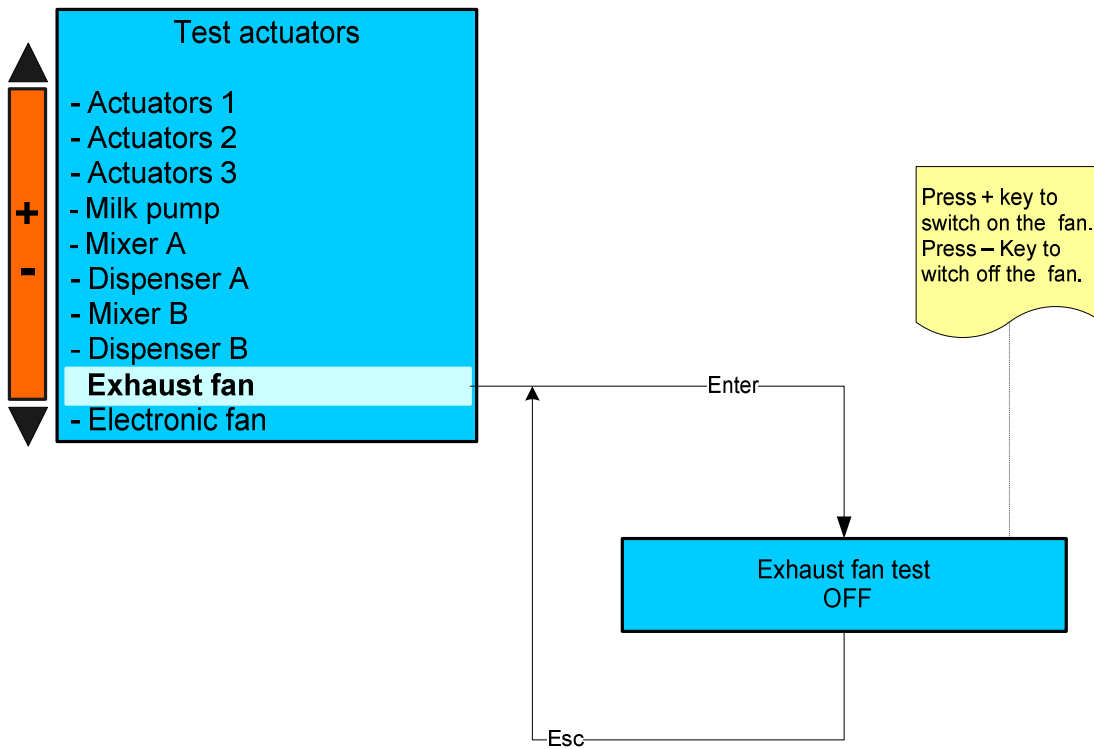

### WARNING:

- You can activate more than one actuator at the same time.
- Once a time-out of 5 seconds has elapsed, the activated actuators will be automatically interrupted.
- The "Milk pump speed" parameter will be displayed only for machine with milk pump installed.

## BOILER DRAINING

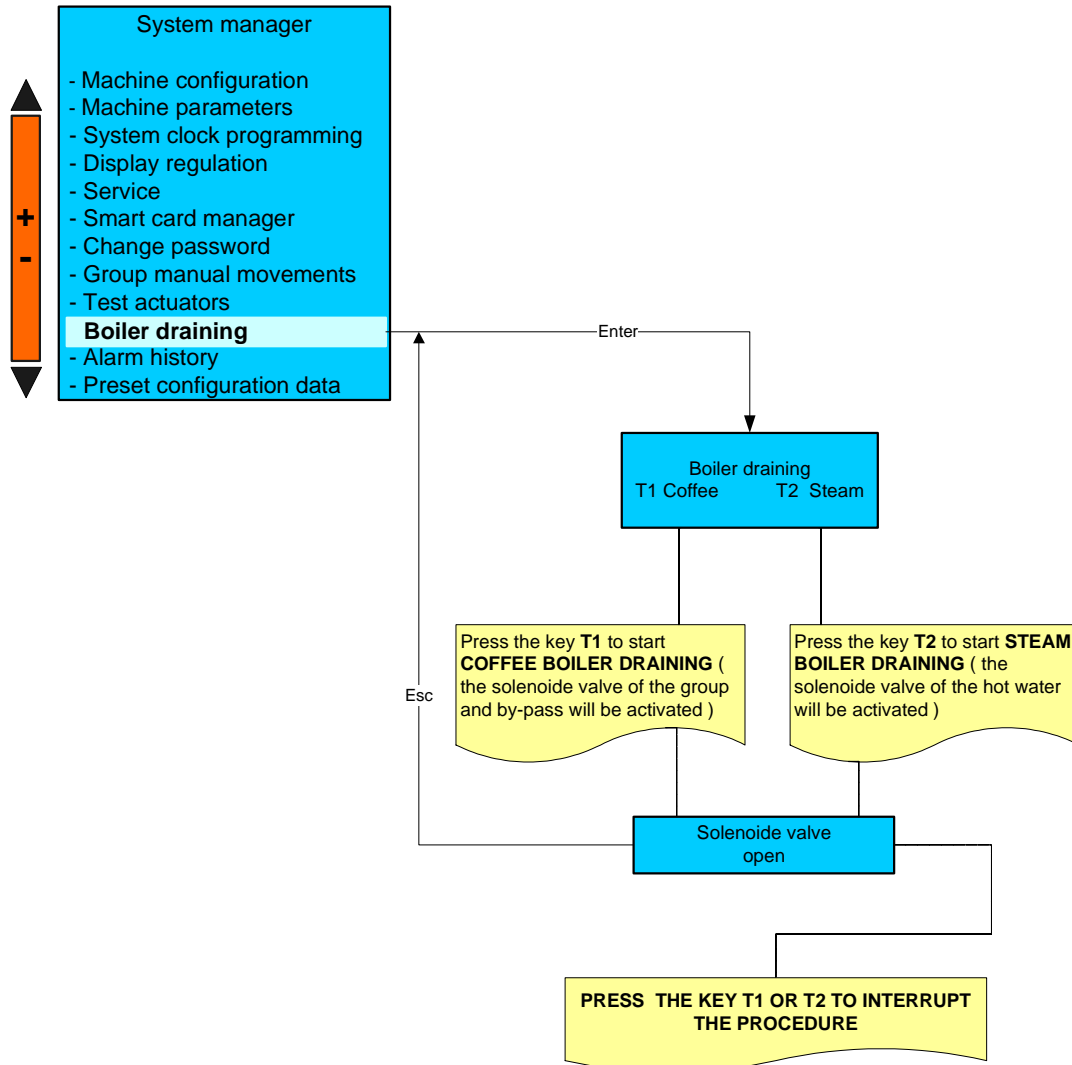

### WARNING:

A) After the boiler draining procedure, when the machine is turned back on, the boilers charge will be carried out according to the procedure described in the chapter "Starting up procedure".



## ALARM HISTORY

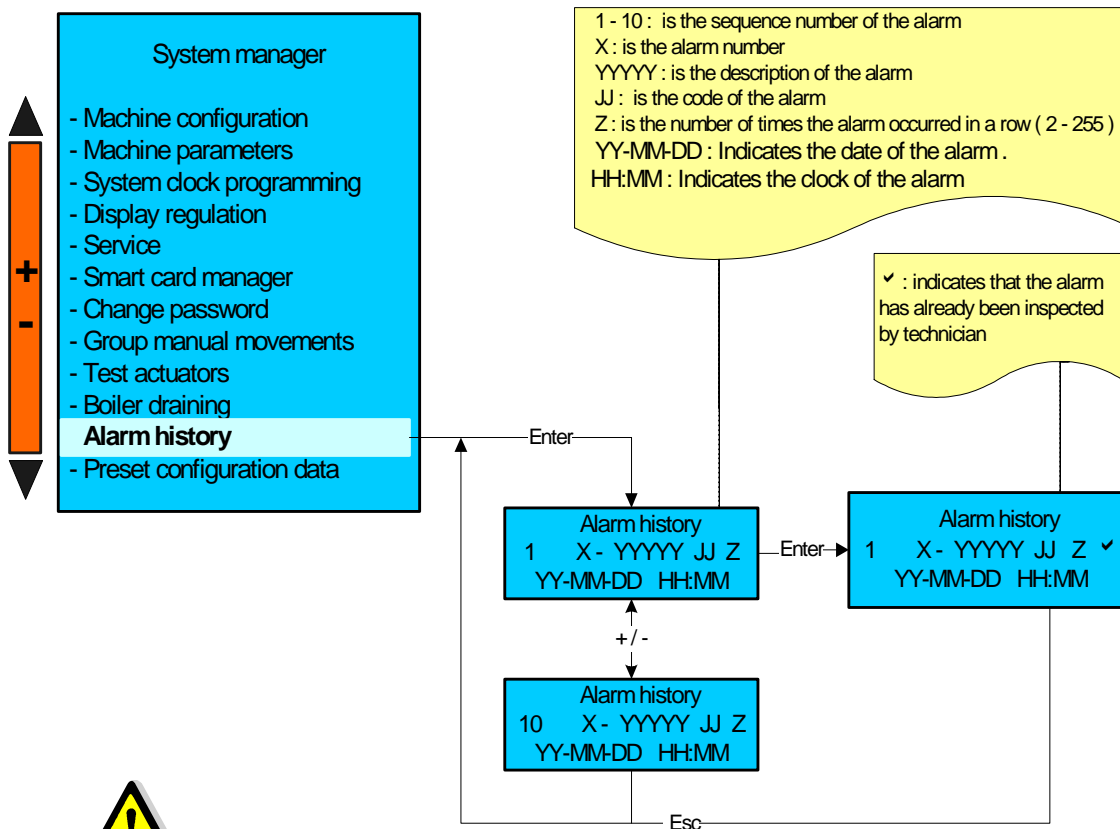

**PRESS INFO KEY TO DISPLAY THE TROUBLE SHOOTING OF THE ALARMS**

ALARM DETAILS	ALARM CODE
NO H. MOTOR PULS	10
NO L. MOTOR PULS	11
H. MOTOR ERROR	12
L. MOTOR ERROR	13
FILLING UP T.O.	32
COFFEE HEAT T.O.	33
STEAM HEAT T.O.	34
CHECK FLOW LINE	35
COFFEE TEMPERATURE	37
STEAM TEMPERATURE	38
INFUSION T.O.	41
CORRUPTED DATA	60
CLOCK ERROR	63
MOTOR BLOCK	65
COIN VALIDATOR ERROR	70
CHANGE H2O FILTER	90
GROUP MAINTENA.	91
GRINDER MAINTENA.	93
TOO MUCH COFFEE	15
MAINTENANCE	92

**Please Note:**

- The maximum alarm number the machine can save is 10.
- To reset the alarm data memory, carry out "Preset Configuration Data" procedure. Press the N°7 Enter key to return to the previous environment and/or exit

## PRESET PARAMETERS

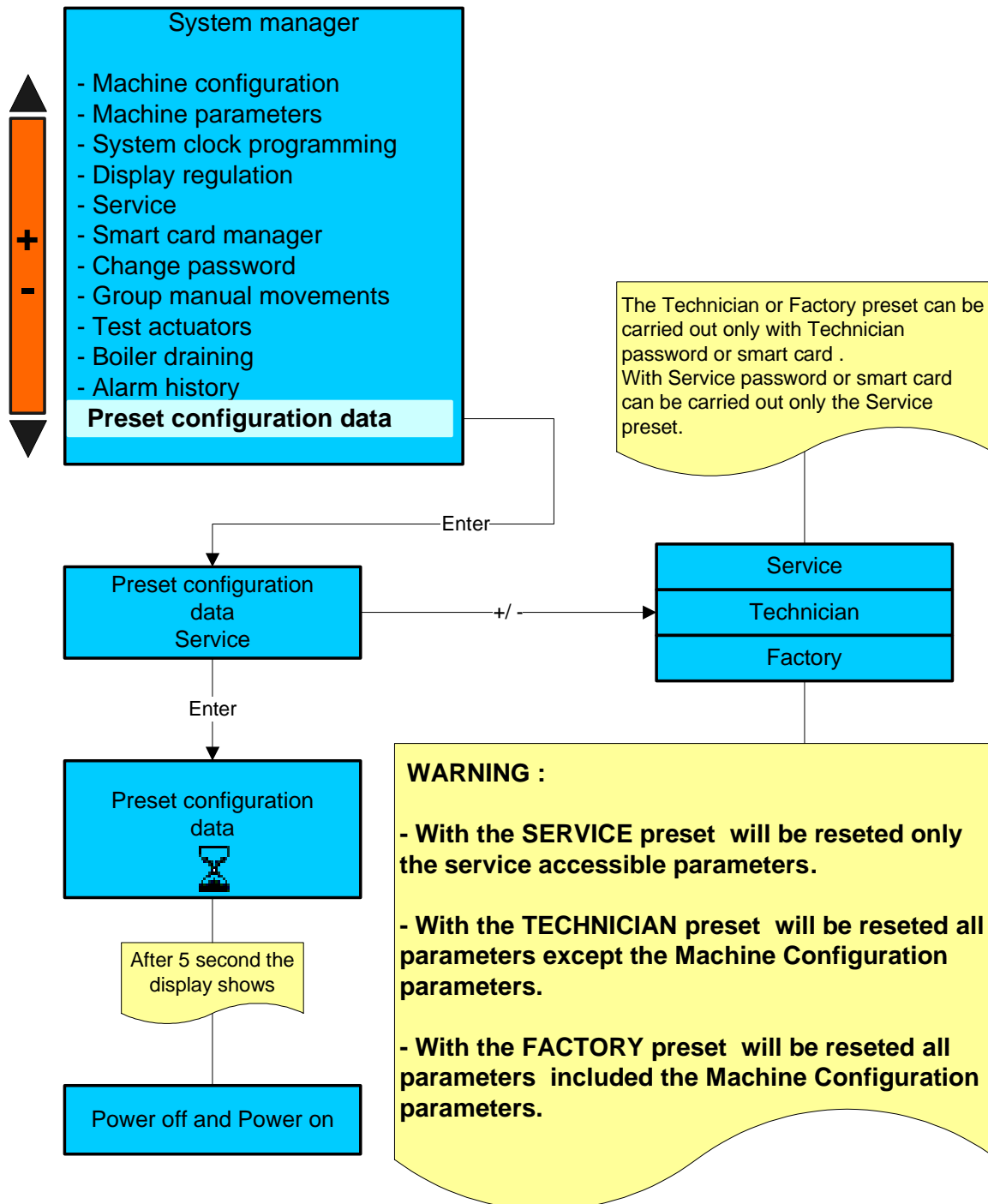

With this function, all the set up values, machine counters and passwords take the default values set up by the manufacturer.

**PLEASE NOTE:**

A -By power OFF and power on, it is meant clearing and giving voltage to the machine.

## CLEANING PROCESS ABORT

If you want to interrupt the cleaning procedure for group or whisk or milk frother follow the procedure:  
( ONLY WITH THE TECHNICIAN OR SERVICE PASSWORD )

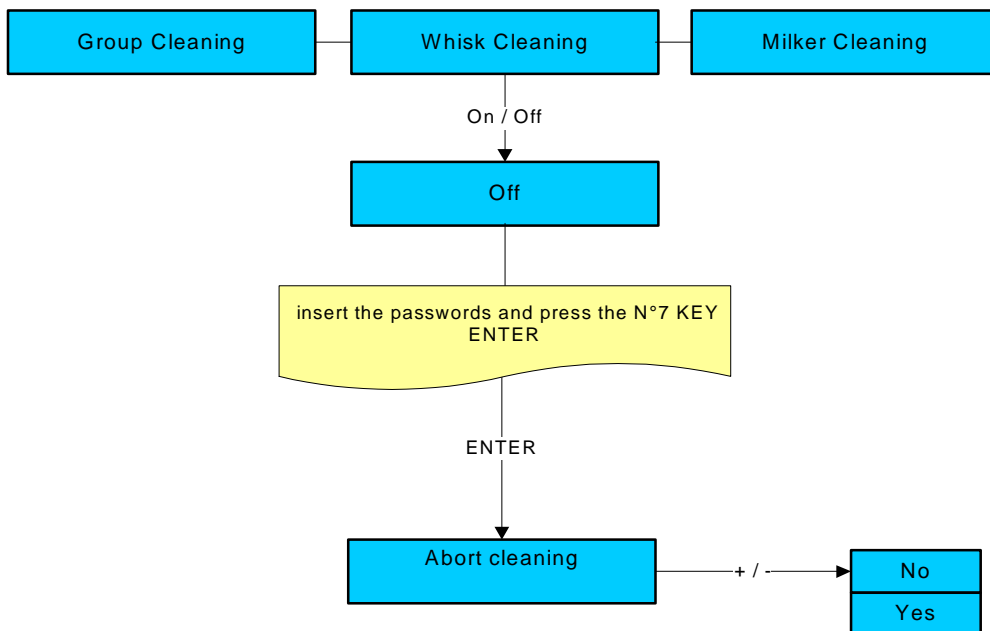

## TROUBLE SHOOTING

### 1) N°10 Time out pulses, upper piston motor.



This alarm is visualised on display by code 10

Causes: the upper motor encoder has not received pulses for 3 seconds, since the motor is not running

Result: the machine is switched OFF.

Check the following:

1. Wrong or misconnect electric connections
2. Faulty gear motor electric
3. Faulty encoder card
4. Faulty master card

### 2) N°11 Time out pulses, lower piston motor.



This alarm is visualised on display by code 11.

Causes: the lower motor encoder has not received pulses for 3 seconds, since the motor is not running.

Result: the machine is switched OFF.

Check the following:

1. Wrong or misconnect electric connections
2. Faulty gear motor electric
3. Faulty encoder card
4. Faulty master card

### 3) N° 12 Upper motor error alarm.



This alarm is visualised on display by code 12

Causes: a mechanical shutdown occurred to the gear motor or the upper piston encoder is not reading the impulses correctly.

Result: the machine is switched OFF.

Check the following:

- 1) Gear motor defective
- 2) Gear motor not aligned with the brewing chamber
- 3) Faulty master card.

### 4) N° 13 Lower motor error alarm.



This alarm is visualised on display by code 13.

Causes: a mechanical shutdown occurred to the gear motor or the lower piston encoder is not reading the impulses correctly

Result: the machine is switched OFF.

Check the following:

- 1) Gear motor defective
- 2) Gear motor not aligned with the brewing chamber
- 3) Faulty master card.

### 5) N° 15 Alarm of too much coffee in the brewing chamber.

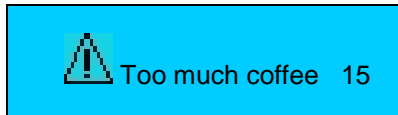

This alarm is visualised on display by code 15

Causes: the upper piston has positioned itself where the wet seal of the piston gasket in the brewing chamber is not guaranteed.

Result: the machine is switched OFF.

Solution: carry out the following controls.

- 1) Reduce coffee quantity
- 2) Clean the upper piston gasket from any coffee residue
- 3) Check the upper piston alignment with the brewing chamber.
- 4) Faulty encoder

**Please Note: before show the alarm the upper piston tries to insert itself into the brewing chamber twice.**

### 6) N° 32 Boiler filling alarm.

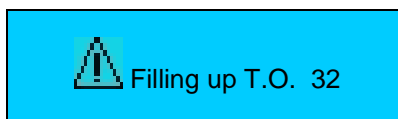

This alarm is visualised on display by code 32

Causes: the stage of boiler fillings has exceeded the maximum time of 2 minutes; the level of the probe (SLC) has not been reached.

Result: the machine is OFF.

Check the following:

- 1) Level probe (SLC) is dirty, so isolated from the water (the complete filling of the boiler is checked)
- 2) no water from mains
- 3) low water pressure
- 4) faulty motor pump
- 5) faulty filling solenoid valve
- 6) incorrect electrical connections (level probe -SLC- misconnected wire).
- 7) PC board relè

### 7) N° 33 Coffee boiler time-out temperature alarm .

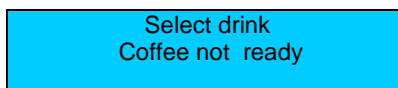

This alarm is visualised on display by code 33

Cause: the coffee boiler temperature has reached the minimum value of 60°C

Result: boiler heating is interrupted and the buttons of coffee-based, milk-based and filter drinks are disabled.

Solution: turn off the machine and then turn it back on. If the alarm sets off again, verify:

**WARNING:**

- a) If the alarm sets off again, wait until the machine reaches the working temperature
- b) If the machine is in OFF mode, the display shows:

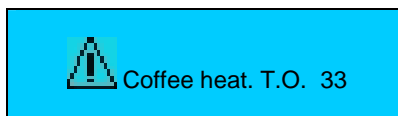

It indicates that the heating up stage of the coffee boiler has exceeded 12' time-out, verify:

- 1) Faulty temperature probe
- 2) Temperature probe stopped
- 3) Faulty TRIAC
- 7) Faulty master board
- 8) Turn the machine in OFF mode and then turn it back on with the key N°11 (ON-OFF).

## 8) N° 34 Steam boiler time-out temperature alarm .

Select drink  
Steam not ready

This alarm is visualised on display by code 34

Cause: the steam boiler temperature has reached the minimum value of 105°C

Result: boiler heating is interrupted and the buttons of coffee-based, milk-based and filter drinks are disabled.

Solution: turn off the machine and then turn it back on.

### WARNING:

- a) If the alarm sets off again, wait until the machine reaches the working temperature
- b) If the machine is in OFF mode, the display shows:

 T.O Steam heat. T.O. 34

It indicates that the heating up stage of the coffee boiler has exceeded 12' time-out, verify:

- 1) Faulty temperature probe
- 2) Temperature probe stopped
- 3) Faulty TRIAC
- 4) The steam boiler safety thermostat has set in (see alarm description of steam boiler safety thermostat)
- 5) Faulty master board
- 6) Turn the machine in OFF mode and then turn it back on with the key N°11 (ON-OFF).

## 9) N° 35 Check flow lines

 Check Flow Lines 35

This alarm is visualised on display by code 35

Cause: It indicates that when the machine is in stand-by there is a leakage from the coffee hydraulic circuit.

Result: the machine is OFF.

Check the following:

- 1) leakage from the expansion valve
- 2) leakage from the third way of the coffee group solenoid valve.
- 3) leakage from the by pass solenoid valve.
- 6) leakage from the tubes of the coffee hydraulic circuit
- 7) leakage from the no-return valve

## 10) N° 37 Coffee boiler temperature alarm.

 Coffee temperat. 37

This alarm is visualised on display by code 37

First case: the temperature inside the coffee boiler has reached the limit value of 105°C (221°F) or more.

Result: boiler heating is interrupted and the buttons of coffee-based, coffee +milk-based and filter drinks are disabled.

Solution: turn OFF the machine. Replace the TRIAC of the heating element coffee boiler. Turn the machine ON.

Second case: the temperature probe is defective. The probe sends the following signal to the pcb: 0 Ohm.

To check the temperature the probe sends to the pcb press key no. 15 without any smart card into the slot

Result: boiler heating is interrupted and the buttons of coffee-based, coffee+ milk-based and filter drinks are disabled.

Solution: turn OFF the machine. Replace the temperature probe. Turn the machine ON.

Third case: the temperature probe is defective. The probe sends the following signal to the pcb: 154 Ohm (short circuit).

To check the temperature the probe sends to the pcb press key no. 15 without any smart card into the slot

Result : boiler heating is interrupted and the buttons of coffee-based, coffee+ milk-based and filter drinks are disabled.

Solution: Turn OFF the machine. Replace the temperature probe. Turn the machine ON.

### 11) N° 38 Steam boiler temperature alarm.

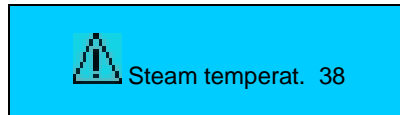

This alarm is visualised on display by code 38

**First case:** the temperature inside the steam boiler has reached the limit value of 129°C (264.2°F) or more.

Result: boiler heating is interrupted and all dose buttons are disabled.

Solution: turn OFF the machine. Replace the TRIAC of the heating element steam boiler. Turn the machine ON.

**Second case:** the temperature probe is defective. The probe sends the following signal to the pcb: 0 Ohm.

Result: boiler heating is interrupted and all dose buttons are disabled.

Solution: turn OFF the machine. Replace the temperature probe. Turn the machine ON.

**Third case:** the temperature probe is defective. The probe sends the following signal to the pcb: 154 Ohm (short circuit).

Result: boiler heating is interrupted and all dose buttons are disabled.

Solution: turn OFF the machine. Replace the temperature probe. Turn the machine ON.

### 12) N° 40 Flowmeter alarm.

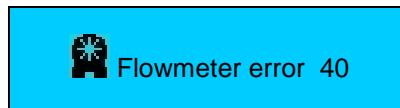

This alarm is visualised on display by code 40.

Cause: the flowmeter is not sending signals to the control unit within a time-out of 5 seconds.

Result: delivery continues up to a time-out of 120 seconds or until the selected key is pressed.

Check the following:

- 1) No water from mains (coffee is not dispensed)
- 2) clogged group piston filters (coffee is not dispensed)
- 3) faulty group solenoid valve (coffee is not dispensed)
- 4) clogged inlet filters (coffee is not dispensed)
- 5) blocked flowmeter (coffee is not dispensed)
- 6) or faulty flowmeter (coffee dispensed continuously)
- 7) faulty electrical connection (coffee dispensed continuously).

Note: If the coffee is dispensed continuously, use the machine as if it were manual: press the required key to start up the dose, then press the same key to stop the dose being dispensed, after checking the amount in the cup.

If dispensing continues until the above mentioned time-out of 120 seconds, the dispensing will be stopped and display shows:

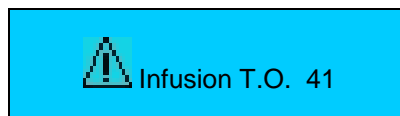

This alarm is visualised on display by code 41.

The message signals that a time-out problem of the flowmeter occurred.

At the next dose the message will be cancelled if dispensing is carried out correctly.

### 13) N° 60 Corrupted data alarm.

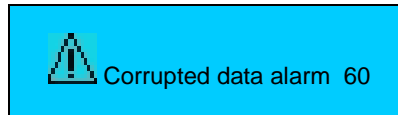

This alarm is visualised on display by code 60

**First case:** This alarm is visualised during machine functioning

Cause: incorrect operating data in machine memory.

Result: machine shutdown.

Solution: carry out the following controls.

1) Verify programming data relevant to the operation that is being carried out. They might be varied and therefore the machine does not recognise the new data.

2) Carry out "PARAMETERS PRESET" procedure (see chapter system programming configuration data preset).

**Second case:** software programming values or data incorrect, data inserted by means of P.C. programming incorrect.

Result: machine shutdown.

Solution:

1) Carry out "PRESET CONFIGURATION DATA" procedure

2) Insert new software by means of P.C.

### 14) N° 63 Clock error.

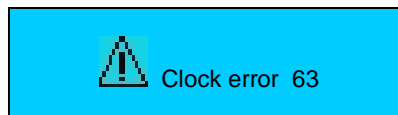

This alarm is visualised on display by code 63

Solution: check the following:

- a) run down battery
- b) faulty master board

### 15) N° 65 Motor block alarm.

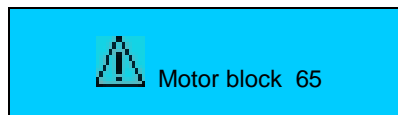

This alarm is visualised on display by code 65

Causes: a mechanical block occurred to the Mixer , Dispenser or Milk pump motors.

Result: the machine is switched OFF.

Check the following:

- 1) Mixer motor defective
- 2) Dispenser motor defective
- 3) Milk pump motor defective

### 16) N°80 Sim card alarm ( only for machine with GSM Modem kit )

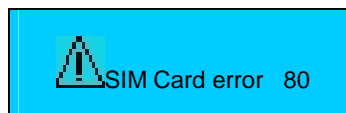

This alarm is visualised on display by code 80

Solution: check the following :

- a) SIM card not inserted into GSM Modem
- b) faulty SIM card.
- c) SIM card not properly inserted.
- d) faulty GSM Modem .



**17) N°81 Modem GSM alarm ( only for machine with GSM Modem kit )**



This alarm is visualised on display by code 81

Solution: check the following :

- a) check the power supply of the gsm modem installed in the coffee machine.
- b) check that the serial cable is properly connected in the gsm modem and in the master board (CN 16).

**18) N°82 PIN of the modem gsm alarm ( only for machine with GSM Modem kit )**



This alarm is visualised on display by code 82

Solution: check that the PIN number programmed in the parameters "GSM : SIM CARD PIN " is the same as the Sim card inserted in the gsm Modem .

**19) N° 90 Water softener alarm.**

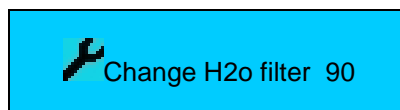

This alarm is visualised on display by code 90

Cause: the flowmeter has reached the maximum value of XXXXX litres of previously programmed water, which may be dispensed.

Result: none.

Solution: renew the softener salts. To cancel the alarm, see the Info -Reset paragraph for further information.

Note: this alarm does not block dispensing. The softener alarm can be excluded by setting the litre value to zero (see Service – Maintenance set-up paragraph).

**20) N° 91 Group maintenance alarm.**

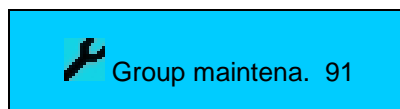

This alarm is visualised on display by code 91

Cause: the group has reached the number of programmed cycles (see Service chapter).

Result: none.

Solution: check the group and cancel the alarm following the procedure of the chapter info reset.

**21) N° 92 Machine maintenance alarm.**



This alarm is visualised on display by code 92

Cause: the machine has reached the number of programmed cycles or the inspection date (see Service chapter).

Result: none.

Solution: check or/and replace the wear parts and cancel the alarm following the procedure of the chapter Info reset.

## 22) N° 93-Tools maintenance alarm.

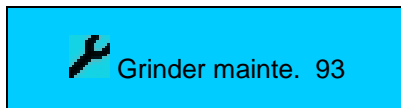

This alarm is visualised on display by code 93

Cause: the tools have reached the set up working time (see Service chapter )

Result: none.

Solution: replace the tools and cancel the alarm following the procedure explained in the info reset chapter.

## 23) Safety valve operation.

No messages on the display

Cause: overpressure in steam boiler

Result: the safety valve opened at 1.7-1.9 bars, the steam is conveyed to the drip tray by means of a silicone tube.

Cause: overpressure in the steam boiler or faulty safety valve.

Solution: carry out the following controls.

- 1) Temperature probe of the boiler (see boiler temperature alarm)
- 2) Contacts of the electromagnetic switch of the electric element are stacked
- 3) Replace the safety valve in case it releases steam at a pressure lower than 1.7 bars,

## 24) Steam boiler Klicson cutoff.

No messages on the display

Cause: The temperature of the boiler has reached the limit of 145°C.

Result: the steam boiler heating is interrupted.

Solution: carry out the following controls.

- 1) Faulty temperature probe
- 2) Faulty TRIAC of the heating element
- 3) Faulty klicson
- 4) Faulty Level probe
- 5) The water level in the boiler has dropped lower than the heating element.

### **WARNING:**

To activate the safety thermostat, it is necessary to press the button placed at the centre of the thermostat itself.

## 25) Coffee boiler Klicson cutoff.

No messages on the display

Cause: The temperature of the boiler has reached the limit of 120°C.

Result: the coffee boiler heating is interrupted.

Solution: carry out the following controls.

- 6) Faulty temperature probe
- 7) Faulty TRIAC of the heating element
- 8) Faulty klicson
- 9) No water inlet.

### **WARNING:**

To activate the safety thermostat, it is necessary to press the button placed at the centre of the thermostat itself.

## SPECIAL FUNCTIONS FOR MACHINE CALIBRATION

### 1) Calibrating the coffee dispensing pressure (pump pressure).

To calibrate the coffee dispensing pressure use the device code A 0128 ( Pic. A ).  
The procedure is the following :

- replace the upper piston with the one equipped with pressure gauge (Pic. B)
- push a coffee dose key and rotate the pump adjusting screw to adjust the coffee dispensing pressure ( 8-9 Bar max.) clockwise to increase it, and anti-clockwise to decrease it. The pressure will be shown on the gauge.

PIC. A



PIC. B



### 2) Calibrating the coffee grinding degree.

a) Turn the screw on the top of the machine anticlockwise and then remove the hopper.

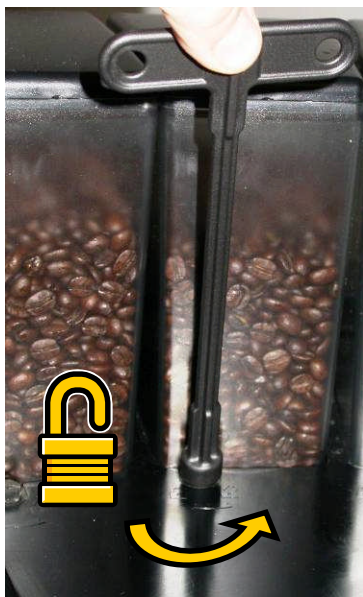

b) Move the adjustment to the right to get coarse coffee powder, to the left for finer.

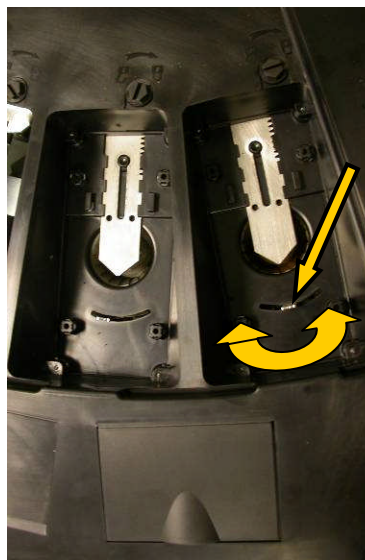

c) Reinsert the hopper and lock it by turning the screw clockwise.



Please Note: Brew and throw two doses, the third one will be dispensed with the new grinder set



**IF THE ADJUSTING RANGE IS NOT WIDE ENOUGH TO GET THE NEEDED GRINDING DEGREE, YOU CAN DO THE FOLLOWING:**

- Remove the hoppers and/or product containers
- Remove the top cover from the machine (unscrew the 2 rear and 2 front screws)
- Unscrew the 2 screws ( PIC.A ) and move the grinding regulator rightwards to get a finer degree and leftwards to get a coarser degree.

**PIC. A**

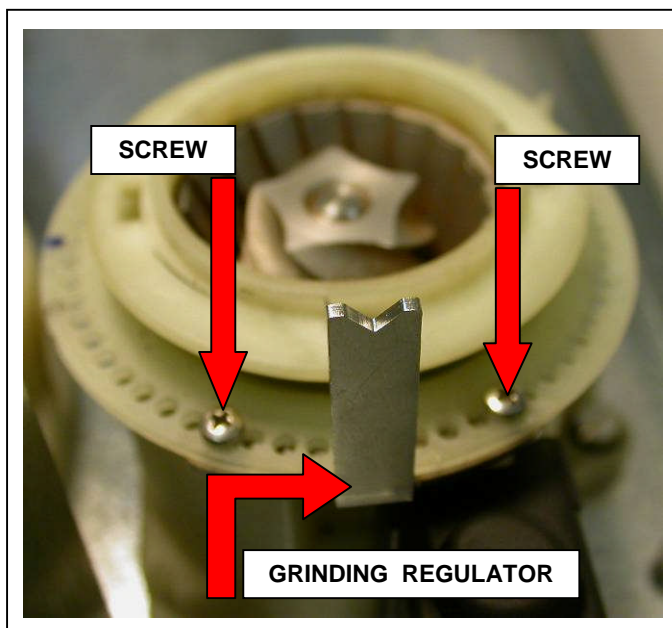

### **3) Calibrating the flow adjustment of the coffee outlet.**

In order to calibrate the dispensing speed and change the amount of coffee cream, turn the screw of the coffee outlet regulator on the upper piston (see hydraulic diagram) clockwise to decrease it and anti-clockwise to increase it. We recommend making the above adjustment while the coffee is being dispensed.

## RECOMMENDATIONS FOR A CORRECT PREVENTIVE MAINTENANCE

The aim of this schedule is to prevent as far as possible equipment from breaking down, through the periodical check-up and replacement of components subject to fair wear and tear, thus reducing service calls and relevant cost in working hours.

This schedule is based on the suppliers recommendations along with previous service history on equipment currently out in the field.

It is designed to assist in extending the operational life of the equipment.

### **A. Pre delivery inspection:**

We test all machines before shipping using water and at least 1/2Kg of coffee. Therefore we consider our machines ready to installation.

Anyway we suggest to carry out a Pre Delivery Inspection on all machines before deliver them to final customer. PDI can detect inconveniences which may occur during transportation or a long storage. For instance:

- screws and nuts which fit the body-work may become loose;
- flowmeter may be block by dust especially after long storage;
- screws which fit the power supply wires may become loose.

### **B. 2 or 3 weeks after installation:**

#### Parts to be checked or adjusted:

1. the grinder/s settings
2. the dose settings
3. if daily cleaning of group and milk frother is carried out by the operator.

### **C. At 4 months' intervals:**

#### Parts to be changed:

1. o-rings for milk frother
2. milk silicone tube for milk frother
3. o-rings for group pistons.

#### Parts to be cleaned or replaced (check and decide on site):

4. o-rings for the drip tray
5. group upper piston micro screen
6. group lower piston screen
7. milk frother
8. clean the hopper by the oil of the coffee
9. clean the coffee chute by means of a dry brush

#### Parts to be checked or adjusted:

10. grinder/s setting (coarseness of the coffee powder)
11. air adjustment for milk frother
12. coffee silicone tube
13. pump pressure should be 8-9 bars, check after had closed the coffee flow valve on upper piston
14. coffee boiler expansion valve should leak at 13 bars after a few coffee deliveries
15. front door induction switch
16. grounds beans tray induction switch
17. heating element of the brewing chamber (PTC), if it's not working check the fuse next to the group (yellow label)
18. check the gasket underneath the sweeper (it is glued to the sweeper)

#### Check the functioning of the machine with the customer:

19. dose settings (setting of milk frother, steam boiler pressure...)
20. that the double coffee spout delivers consistent quantity of coffee in the cup, if not replace it
21. check how many times the group cleaning procedure has been carried out
22. check how many times the milk frother cleaning procedure has been carried out.

### **D. Check at 12 months' intervals**

#### Same as points C1-22, plus replace the following:

1. steam boiler safety valve
2. coffee boiler expansion valve
3. grinder/s burrs (average 300-500 Kg)
4. if the group has delivered 75.000 drinks replace the motors
5. group upper piston micro screen
6. group lower piston screen
7. milk frother
8. milk frother air adjustment.

#### Suggestions:

Use the Test Actuators menu to check all loads of the machine: grinder/s, solenoid valves, contactor and heating element.  
Check Alarm History menu, if you find any alarm check and solve the problem.  
Test Actuators and Alarm History menu are part of the System Manager menu.

**PLEASE NOTE:** It is very important to verify that your customers carry out recommended daily cleaning procedures of brewing unit and milk frother. More parts may be checked depending on your personal experience and also coffee/water quality.

### CONTROL UNIT LEGEND

**A) MASTER BOARD code no. 96.00841** (see electric diagram)

#### Functions of the fuses:

FU1 value: 4 A 250V. type: D : fuse for mixer motor 1  
FU2 value: 4 A 250V. type: D : fuse for mixer motor 2

**Please Note :**

**THE OTHER ACTUATORS ARE PROTECTED FROM ELECTRONIC FUSES ( PTC – VDR ).**

#### **B) MASTER BOARD LED LEGEND**

**LED1 LD1 - Vcc :** ( red colour) 5 V. DC power supply for microprocessor and electronic component

**LED LD2 - VH:** ( red colour) 24 V. DC main power supply for master board

**LED LD3 - VREG :** ( red colour) 12 V. DC power supply for triac and on/off relays

## Information for users in the european community

*Pursuant to European Directive 2002/96/EC on electrical waste (WEEE), users the European community are advised of the following.*

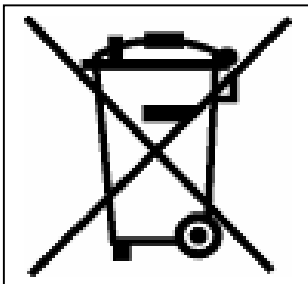

- *The symbol with the crossed-out dustbin on the appliance or its packaging indicates that at the end of the product's life cycle, it must be collected separately from other waste.*
- *Suitable separate collection of the equipment for the subsequent recycling, treatment and disposal contributes to preventing possible negative consequences for the environment and health, and favours the recycling of materials that the unit is made of.*

• *In accordance with European Directive 2002/96/EC, abusive disposal of the product by the user will result in application of penalties as set forth by local law.*

---

The manufacturer reserves the right to change, without prior notice, the specifications of the equipment illustrated in this publication; the manufacturer declines all responsibility for any mistakes due to printing and/or typing errors contained in this publication.

All instructions, drawings, tables and information contained in this publication are reserved and may not be reproduced entirely or in part or be communicated to a third party without written authorisation from the manufacturer who holds exclusive rights.