

This NX-800H (K3 version) service manual contains a number of sections which differ from the service manual (B51-8823-00) for NX-800/800H (K version). For items other than those in this NX-800H (K3 version) service manual, please refer to the service manual (B51-8823-00) for NX-800/800H (K version).

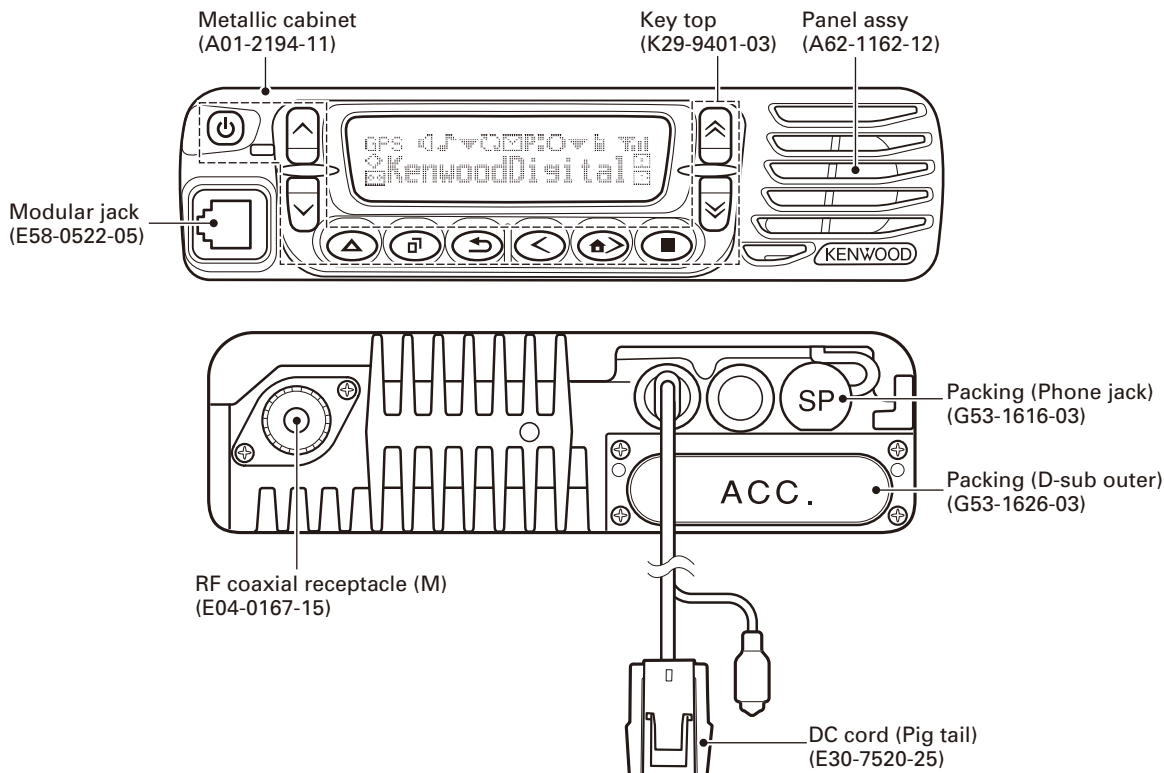

CONTENTS

GENERAL	2	TX-RX UNIT (X57-7750-18) (A/2)	42
SYSTEM SET-UP	4	TX-RX UNIT (X57-7750-18) (B/2)	46
REALIGNMENT	5	INTERCONNECTION DIAGRAM	47
CIRCUIT DESCRIPTION	7	SCHEMATIC DIAGRAM	48
PARTS LIST	8	LEVEL DIAGRAM	66
EXPLODED VIEW	20	BLOCK DIAGRAM	68
ADJUSTMENT	21	SPECIFICATIONS	71
PC BOARD			
DISPLAY UNIT (X54-3680-10)	40		

NX-800H

Document Copyrights

Copyright 2009 by Kenwood Corporation. All rights reserved.

No part of this manual may be reproduced, translated, distributed, or transmitted in any form or by any means, electronic, mechanical, photocopying, recording, or otherwise, for any purpose without the prior written permission of Kenwood.

Disclaimer

While every precaution has been taken in the preparation of this manual, Kenwood assumes no responsibility for errors or omissions. Neither is any liability assumed for damages resulting from the use of the information contained herein. Kenwood reserves the right to make changes to any products herein at any time for improvement purposes.

Firmware Copyrights

The title to and ownership of copyrights for firmware embedded in Kenwood product memories are reserved for Kenwood Corporation. Any modifying, reverse engineering, copy, reproducing or disclosing on an Internet website of the firmware is strictly prohibited without prior written consent of Kenwood Corporation. Furthermore, any reselling, assigning or transferring of the firmware is also strictly prohibited without embedding the firmware in Kenwood product memories.

Transceivers containing AMBE+2™ Vocoder:

The AMBE+2™ voice coding technology is embedded in the firmware under the license of Digital Voice Systems, Inc.

GENERAL

INTRODUCTION

SCOPE OF THIS MANUAL

This manual is intended for use by experienced technicians familiar with similar types of commercial grade communications equipment. It contains all required service information for the equipment and is current as of this publication date. Changes which may occur after publication are covered by either Service Bulletins or Manual Revisions, which are issued as required.

ORDERING REPLACEMENT PARTS

When ordering replacement parts or equipment information, the full part identification number should be included. This applies to all parts: components, kits, and chassis. If the part number is not known, include the chassis or kit number of which it is a part and a sufficient description of the required component for proper identification.

PERSONAL SAFETY

The following precautions are recommended for personal safety :

- DO NOT transmit if someone is within two feet (0.6 meter) of the antenna.
- DO NOT transmit until all RF connectors are secure and any open connectors are properly terminated.
- SHUT OFF this equipment when near electrical blasting caps or while in an explosive atmosphere.
- All equipment should be properly grounded before power-up for safe operation.
- This equipment should be serviced by only qualified technicians.

PRE-INSTALLATION CONSIDERATIONS

1. UNPACKING

Unpack the radio from its shipping container and check for accessory items. If any item is missing, please contact KENWOOD immediately.

2. PRE-INSTALLATION CHECKOUT

2-1. Introduction

Each radio is adjusted and tested before shipment. However, it is recommended that receiver and transmitter operation be checked for proper operation before installation.

2-2. Testing

The radio should be tested complete with all cabling and accessories as they will be connected in the final installation. Transmitter frequency, deviation, and power output should be checked, as should receiver sensitivity, squelch operation, and audio output. Signaling equipment operation should be verified.

3. PLANNING THE INSTALLATION

3-1. General

Inspect the vehicle and determine how and where the radio antenna and accessories will be mounted.

Plan cable runs for protection against pinching or crushing wiring, and radio installation to prevent overheating.

3-2. Antenna

The favored location for an antenna is in the center of a large, flat conductive area, usually at the roof center. The trunk lid is preferred, bond the trunk lid and vehicle chassis using ground straps to ensure the lid is at chassis ground.

GENERAL

3-3. Radio

The universal mount bracket allows the radio to be mounted in a variety of ways. Be sure the mounting surface is adequate to support the radio's weight. Allow sufficient space around the radio for air cooling. Position the radio close enough to the vehicle operator to permit easy access to the controls when driving.

3-4. DC Power and wiring

1. This radio may be installed in negative ground electrical systems only. Reverse polarity will cause the cable fuse to blow. Check the vehicle ground polarity before installation to prevent wasted time and effort.
2. Connect the positive power lead directly to the vehicle battery positive terminal. Connecting the Positive lead to any other positive voltage source in the vehicle is not recommended.
3. Connect the ground lead directly to the battery negative terminal.
4. The cable provided with the radio is sufficient to handle the maximum radio current demand. If the cable must be extended, be sure the additional wire is sufficient for the current to be carried and length of the added lead.

4. INSTALLATION PLANNING – CONTROL STATIONS

4-1. Antenna system

Control station. The antenna system selection depends on many factors and is beyond the scope of this manual. Your KENWOOD dealer can help you select an antenna system that will best serve your particular needs.

4-2. Radio location

Select a convenient location for your control station radio which is as close as practical to the antenna cable entry point. Secondly, use your system's power supply (which supplies the voltage and current required for your system). Make sure sufficient air can flow around the radio and power supply to allow adequate cooling.

SERVICE

This radio is designed for easy servicing. Refer to the schematic diagrams, printed circuit board views, and alignment procedures contained in this manual.

NOTE

- If you do not intend to use the speaker 3.5-mm jack and the D-sub 25-pin connector, fit the supplied speaker-jack cap and D-sub cap to stop dust and sand from getting in.
- If the transceiver is turned ON or OFF when the power-on/off status message is enabled, the transceiver sends the status.

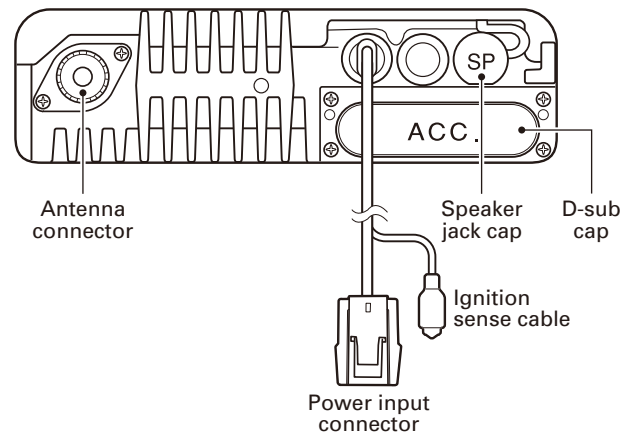

Service Manual List

Title	Parts number	Remarks	Market code	Display unit number	TX-RX unit number	For Service unit number
NX-800	B51-8803-00	First edition	K	X54-3640-10 J79-0157-19	X57-7390-10 J79-0130-19	X57-7750-14 (K)
NX-800/800H	B51-8823-00	First edition	K, HK	*X54-3640-10 J79-0157-29	X57-7390-XX J72-0130-29	X57-7750-14 (K) X57-7750-15 (HK)
NX-800/800H	B51-8848-00	Supplement	K2, HK2	*X54-3640-10 J79-0157-39	X57-7390-XX J79-0239-09	X57-7750-16 (K2) X57-7750-17 (HK2)
NX-800H	B51-8897-00	Supplement This service manual	HK3	*X54-3680-10 J79-0157-39	X57-7750-18 J79-0208-19	X57-7750-19 (HK3)

*Note: The circuit pattern of J79-0157-29 and J79-0157-39 is the same.

NX-800H

SYSTEM SET-UP

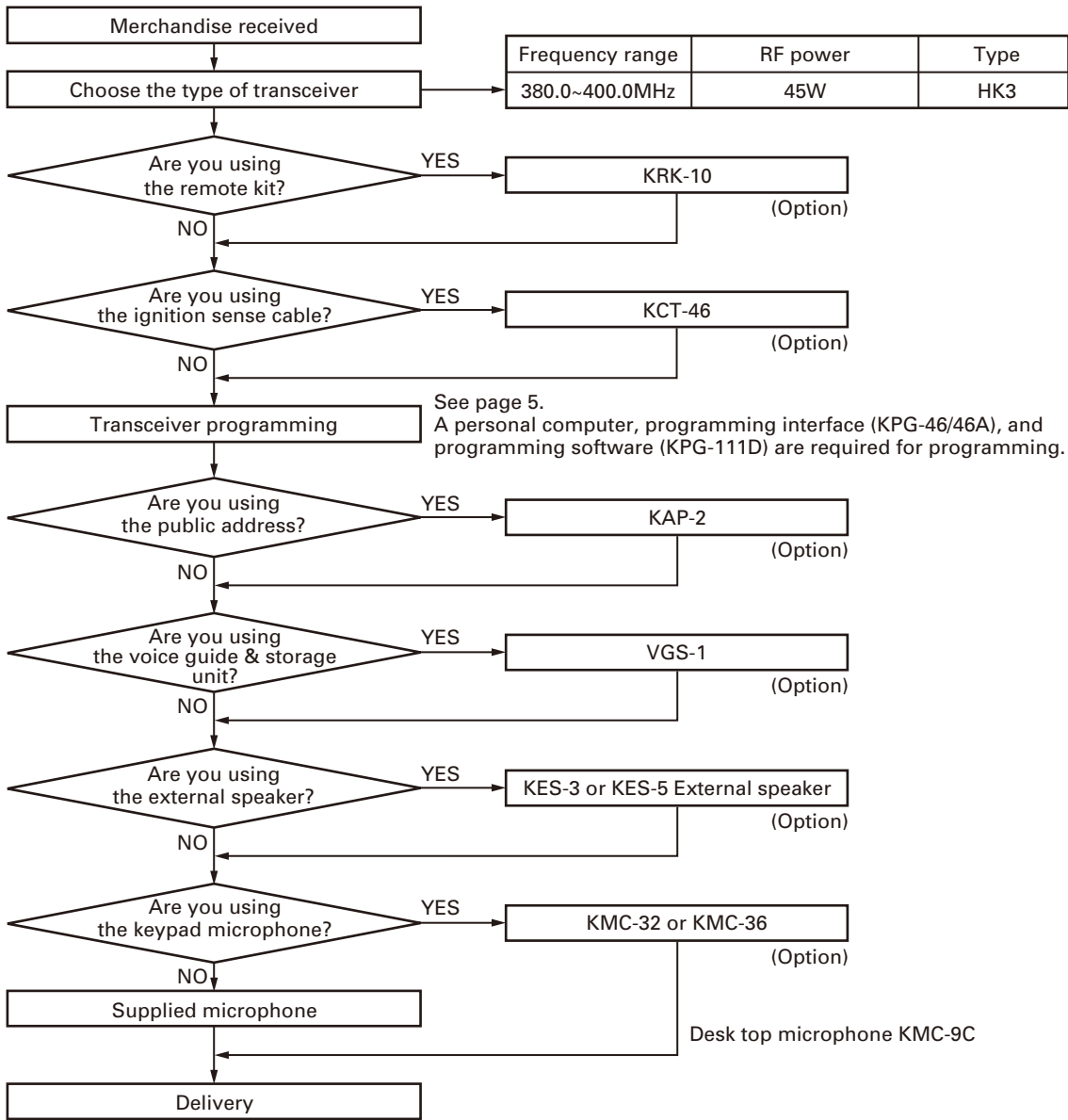

REALIGNMENT

1. Modes

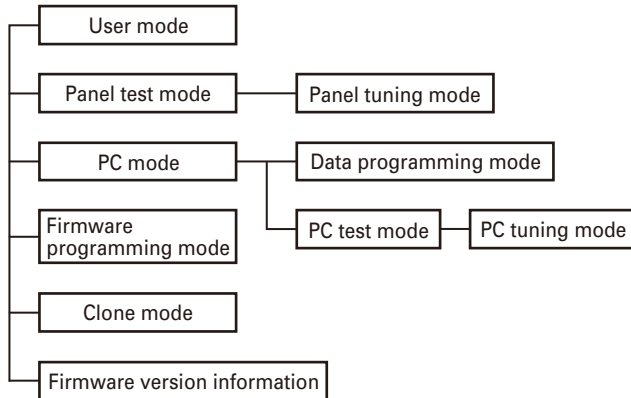

Mode	Function
User mode	For normal use.
Panel test mode	Used by the dealer to check the fundamental characteristics.
Panel tuning mode	Used by the dealer to tune the transceiver.
PC mode	Used for communication between the transceiver and PC.
Data programming mode	Used to read and write frequency data and other features to and from the transceiver.
PC test mode	Used to check the transceiver using the PC. This feature is included in the FPU.
PC tuning mode	Used to tune the transceiver using the PC. This feature is included in the FPU.
Firmware programming mode	Used when changing the main program of the flash memory.
Clone mode	Used to transfer programming data from one transceiver to another.
Firmware version information	Used to confirm the internal firmware version.

2. How to Enter Each Mode

Mode	Operation
User mode	Power ON
Panel test mode	[↵] + Power ON
PC mode	Received commands from PC
Panel tuning mode	[Panel test mode] + [↵]
Firmware programming mode	[↵] + Power ON
Clone mode	[<] + Power ON
Firmware version information	[▲] + Power ON

3. Panel Test Mode

Setting method refer to ADJUSTMENT.

4. Panel Tuning Mode

Setting method refer to ADJUSTMENT.

5. PC Mode

5-1. Preface

The transceiver is programmed by using a personal computer, programming interface (KPG-46/46A) and programming software (KPG-111D: ver. 1.80 or later).

The programming software can be used with a PC. Figure 1 shows the setup of a PC for programming.

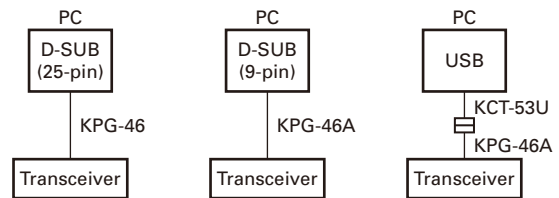
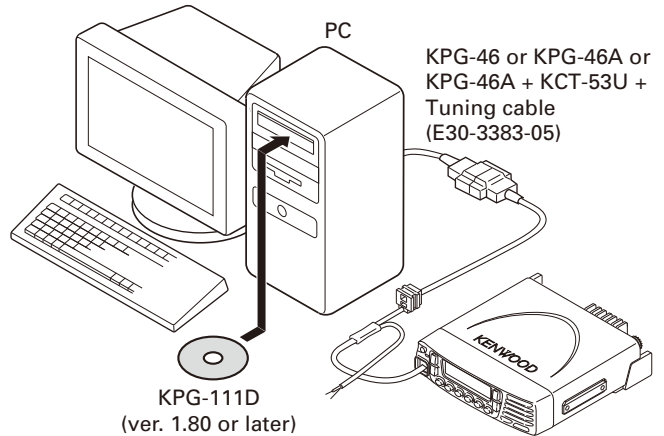

Fig. 1

5-2. Connection procedure

1. Connect the transceiver to the computer using the interface cable and USB adapter (When the interface cable is KPG-46A, the KCT-53U can be used.).

Note:

- You must install the KCT-53U driver in the computer to use the USB adapter (KCT-53U).
- When using the USB adapter (KCT-53U) for the first time, plug the KCT-53U into a USB port on the computer with the computer power ON.

2. When the POWER switch on, user mode can be entered immediately. When PC sends command the transceiver enter PC mode, and "PROGRAM" is displayed on the LCD.

When data transmitting from transceiver, the red LED is lights.

When data receiving to transceiver, the green LED is lights.

Note:

The data stored in the computer must match the "Model Name" when it is written into the flash memory.

REALIGNMENT

5-3. KPG-46/KPG-46A description

(PC programming interface cable: Option)

The KPG-46/46A is required to interface the transceiver to the computer. It has a circuit in its D-sub connector (KPG-46: 25-pin, KPG-46A: 9-pin) case that converts the RS-232C logic level to the TTL level.

The KPG-46/46A connects the 8-pin microphone connector of the transceiver to the RS-232C serial port of the computer.

5-4. KCT-53U description (USB adapter: Option)

The KCT-53U is a cable which connects the KPG-46A to a USB port on a computer.

When using the KCT-53U, install the supplied CD-ROM (with driver software) in the computer. The KCT-53U driver runs under Windows 2000, XP or Vista (32-bit).

5-5. Programming software KPG-111D description

The KPG-111D is the programming software for the transceiver supplied on a CD-ROM. This software runs under Windows 2000, XP or Vista (32-bit) on a PC.

The data can be input to or read from the transceiver and edited on the screen. The programmed or edited data can be printed out. It is also possible to tune the transceiver.

6. Firmware Programming Mode

6-1. Preface

Flash memory is mounted on the transceiver. This allows the transceiver to be upgraded when new features are released in the future. (For details on how to obtain the firmware, contact Customer Service.)

6-2. Connection procedure

Connect the transceiver to the personal computer using the interface cable (KPG-46/46A) and USB adapter (KCT-53U: when the interface cable is KPG-46A, the KCT-53U can be used.). (Connection is the same as in the PC Mode.)

Note:

You can only program firmware from the 8-pin microphone connector on the front panel. Using the 25-pin logic interface on the rear panel will not work.

6-3. Programming

1. Start up the firmware programming software (Fpro.exe (ver. 4.0 or later)). The Fpro.exe exists in the KPG-111D installed folder.
2. Set the communications speed (normally, 115200 bps) and communications port in the configuration item.
3. Set the firmware to be updated by File name item.
4. Turn the transceiver power ON with the [P] key held down. Then, the orange LED on the transceiver lights and "PROGRAM 115200" is displayed.
5. Check the connection between the transceiver and the personal computer, and make sure that the transceiver is in the Program mode.
6. Press [write] button in the window. When the transceiver starts to receive data, the "LOADING" display lights.

7. If writing ends successfully, the checksum is calculated and a result is displayed.
8. If you want to continue programming other transceivers, repeat steps 4 to 7.

Note:

This mode cannot be entered if the Firmware Programming mode is set to Disable in the Programming software.

6-4. Function

1. If you press the [■] key while "PROGRAM 115200" is displayed, the display changes to "PROGRAM 19200" (The LED blinks green) to indicate that the write speed is low speed (19200 bps). If you press the [■] key again while "PROGRAM 19200" is displayed, the display changes to "PROGRAM 38400" (The LED lights red and orange alternatively). If you press the [■] key again while "PROGRAM 38400" is displayed, the display changes to "PROGRAM 57600" (The LED blinks orange). If you press the [■] key again while "PROGRAM 57600" is displayed, the display returns to "PROGRAM 115200" (The LED lights orange).
2. If you press the [▲] key while "PROGRAM 115200" is displayed, the checksum is calculated, and a result is displayed. If you press the [▲] key again while the checksum is displayed, "PROGRAM 115200" is redisplayed.

Note:

Normally, write in the high-speed mode.

7. Clone Mode

Programming data can be transferred from one transceiver to another by connecting them via their 8-pin microphone connectors. The operation is as follows (the transmit transceiver is the source and the receive transceiver is a target).

The following data cannot be cloned.

- Tuning data
- Embedded message with password
- ESN (Electronic Serial Number) data

Note:

The following data can be cloned.

- Fleet (own)/ID (own) for FleetSync
- Unit ID (own) for NXDN

1. Turn the source transceiver power ON with the [K] key held down. If the read authorization password is set to the transceiver, the transceiver displays "CLONE LOCK" If the password is not set, the transceiver displays "CLONE MODE".
2. When you enter the correct password, and "CLONE MODE" is displayed, the transceiver can be used as the cloning source. The following describes how to enter the password.

REALIGNMENT

3.
 - **How to enter the password with the microphone key-pad;**
If you press a key while "CLONE LOCK" is displayed, the number that was pressed is displayed on the transceiver. Each press of the key shifts the display in order to the left. When you enter the password and press the [*] key, "CLONE MODE" is displayed if the entered password is correct. If the password is incorrect, "CLONE LOCK" is redisplayed.
 - **How to enter the password with the [↵] and [↶] keys;**
If the [↵] and [↶] keys is pressed while "CLONE LOCK" is displayed, number (0 to 9) are displayed flashing. When you press the [↵] key, the currently selected number is determined. If you press the [↵] key after entering the password in this procedure, "CLONE MODE" is displayed if the entered password is correct. If the password is incorrect, "CLONE LOCK" is redisplayed.
4. Power on the target transceiver.
5. Connect the cloning cable (Part No. E30-3382-05) to the modular microphone jacks on the source and target.
6. Press the [↵] key on the source while the source displays "CLONE MODE". The data of the source is sent to the target. While the target is receiving the data, "PROGRAM" is displayed. When cloning of data is completed, the source displays "END", and the target automatically operates in the User mode. The target can then be operated by the same program as the source.

7. The other target can be continuously cloned. When the [↵] key on the source is pressed while the source displays "END", the source displays "CLONE MODE". Carry out the operation in step 4 to 6. Can not be cloned if the overwrite password is programmed to the target.

Note:

Only the same models can be cloned together.

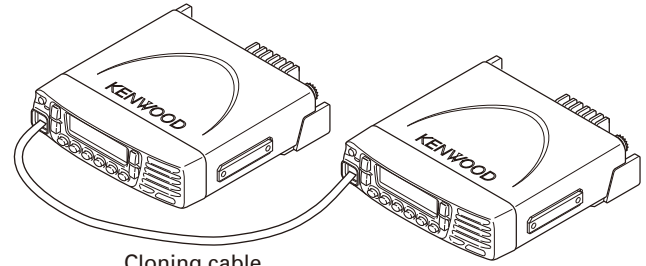

Cloning cable
(E30-3382-05)

Fig. 2

8. Firmware Version Information

Press and hold the [▲] key while turning the transceiver power ON and then keep pressing and holding the [▲] key, the firmware version information appears on the LCD.

CIRCUIT DESCRIPTION

1. Overview

NX-800H (K3) is a UHF Mobile transceiver designed to operate in the frequency range of 380 to 400MHz (in user mode). The unit consists of receiver, transmitter, phase-locked loop (PLL) frequency synthesizer, base band parts, power supply, and control circuits.

2. Frequency Configuration

The receiver is a double-conversion super heterodyne using first intermediate frequency (IF) of 58.05MHz and second IF of 450kHz. Incoming signals from the antenna are mixed with the local signal from the PLL circuit to produce the first IF of 58.05MHz. This is then mixed with the 57.6MHz second local oscillator output to produce the 450kHz second IF. The transmit signal frequency is generated by the PLL VCO, and modulated by the signal from the DSP. It is then amplified and fed to the antenna.

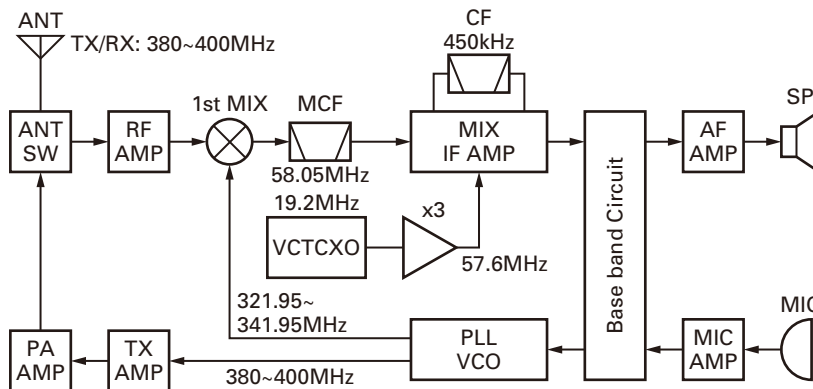

Fig. 1 Frequency configuration

NX-800H

PARTS LIST

* New Parts. Δ indicates safety critical components.

Parts without **Parts No.** are not supplied.

Les articles non mentionnés dans le **Parts No.** ne sont pas fournis.

Teile ohne **Parts No.** werden nicht geliefert.

L : Scandinavia

Y : PX (Far East, Hawaii)

C : China

K : USA

T : England

X : Australia

P : Canada

E : Europe

M : Other Areas

NX-800H

DISPLAY UNIT (X54-3680-10)

Ref. No.	Address	New parts	Parts No.	Description	Destination
NX-800H					
1	1B		A01-2194-11	METALLIC CABINET	
2	3A		A62-1162-12	PANEL ASSY	
4	2A		B09-0681-03	CAP (KAP-2)	
5	3B		B11-1871-04	FILTER(LCD)	
6	3B		B38-0922-15	LCD ASSY	
7	3A		B42-7417-04	STICKER (NEXEDGE)	
8	1D		B62-2146-00	INSTRUCTION MANUAL	
10	2B		E04-0167-15	RF COAXIAL RECEPTACLE (M)	
11	2B		E30-7520-25	DC CORD (PIG TALE)	
12	2C		E30-7523-55	DC CORD ASSY ACCESSORY	
13	1A		E37-1118-05	LEAD WIRE WITH CONNECTOR (SHOUT CABLE)	
14	3B		E37-1124-05	LEAD WIRE WITH CONNECTOR (2P/SP)	
15	2A		E37-1448-05	FLAT CABLE (30P/D-SUB)	
16	2A		E37-1449-05	FLAT CABLE (30P/PANEL)	
18	2B		F10-2488-12	SHIELDING PLATE (CHASSIS)	
19	1A		F10-3032-14	SHIELDING CASE (FINAL)	
20	1A		F10-2490-13	SHIELDING CASE (VCO)	
17	1A		F10-3112-03	SHIELDING CASE (POWER MODULE)	
21	2C		F52-0024-05	FUSE (BLADE TYPE) 15A/32V	
-			G10-1322-04	FIBROUS SHEET (PANEL-SP)	
24	3B		G10-1342-04	FIBROUS SHEET	
25	3B		G10-1802-04	FIBROUS SHEET (LCD)	
-			G11-4336-04	SHEET (PANEL-FG)	
26	1B		G11-4343-04	SHEET (STEP)	
22	1B		G13-2101-04	CONDUCTIVE CUSHION (PM BOTTOM)	
23	1A		G13-2102-04	CONDUCTIVE CUSHION (PM TOP)	
27	1A		G13-2018-04	CUSHION (FINAL)	
28	2B		G13-2047-04	CUSHION (DC SCREW)	
29	2A		G13-2071-04	CONDUCTIVE CUSHION (PLL)	
37	2B		G13-2279-04	CUSHION (FFC)	
30	1B		G53-1613-11	PACKING (SHELD PLATE)	
31	1A		G53-1616-03	PACKING (PHONE JACK)	
32	2B		G53-1626-03	PACKING (D-SUB OUTER)	
33	2B		G53-1643-04	PACKING (DC CORD)	
34	2A		G53-1645-03	PACKING (D-SUB INNER)	
35	2A		G53-1662-04	PACKING (ANT)	
36	3A		G53-1676-03	PACKING	
38	3C	*	H02-0624-13	INNER CARTON CASE	
39	2D	*	H12-4274-03	PACKING FIXTURE (UPPER)	
40	2D	*	H12-4275-02	PACKING FIXTURE (LOWER)	
41	3D		H52-2306-02	ITEM CARTON CASE	
44	2C		J19-1584-15	HOLDER (MIC) ACCESSORY	
45	3B		J19-5464-13	HOLDER (SP)	
46	3B		J19-5485-12	HOLDER (PANEL)	
47	3B		J19-5502-03	HOLDER (LCD)	
48	2B		J21-8479-02	MOUNTING HARDWARE (D-SUB)	
49	3B		J21-8481-03	MOUNTING HARDWARE (SP)	
50	3B		J21-8569-03	MOUNTING HARDWARE (LCD)	
51	2C		J29-0726-03	BRACKET ACCESSORY	
52	3B		J30-1289-04	SPACER (SP SHEET)	
54	3A		K29-9401-03	KEY TOP	

Ref. No.	Address	New parts	Parts No.	Description	Destination
A	2B		N09-2292-05	HEXAGON HEAD SCREW	
B	1A		N67-3008-48	PAN HEAD SEMS SCREW	
C	1A,2B		N87-2606-43	BRAZIER HEAD TAPTITE SCREW	
D	1A,2A,2B		N87-2608-48	BRAZIER HEAD TAPTITE SCREW	
56	2C		N99-2039-05	SCREW SET ACCESSORY	
58	3B		T07-0757-15	SPEAKER	
59	1C		T91-0639-55	MICROPHONE ACCESSORY	
-		*	X57-7750-19	TX-RX UNIT (FOR SERVICE)	
DISPLAY UNIT (X54-3680-10)					
D914			B30-2304-05	LED (RED/GREEN)	
D915-926			B30-2281-05	LED (1608/Y)	
D927-936			B30-2282-05	LED (1608/Y)	
C903			CK73HB1E103K	CHIP C 0.010UF K	
C905			CK73HB1A104K	CHIP C 0.10UF K	
C906			CK73HB1H222K	CHIP C 2200PF K	
C907-909			CK73HB1H102K	CHIP C 1000PF K	
C910-912			CC73HCH1H101J	CHIP C 100PF J	
C913			CK73HB1A104K	CHIP C 0.10UF K	
C914			CK73HB1H102K	CHIP C 1000PF K	
C915			CK73FB1E475K	CHIP C 4.7UF K	
C916			CK73GB1E105K	CHIP C 1.0UF K	
C917,918			CK73HB1A104K	CHIP C 0.10UF K	
C919			CK73HB1H102K	CHIP C 1000PF K	
C920			CC73HCH1H121J	CHIP C 120PF J	
C921			CK73HB1A104K	CHIP C 0.10UF K	
C922-925			CK73HB1H102K	CHIP C 1000PF K	
C926-929			CK73HB1A104K	CHIP C 0.10UF K	
C930			CK73GB1E105K	CHIP C 1.0UF K	
C931,932			CK73HB1H102K	CHIP C 1000PF K	
C933			CK73GB1E105K	CHIP C 1.0UF K	
C934			CK73HB1H102K	CHIP C 1000PF K	
C935			CS77BA1E4R7M	CHIP TMTL 4.7UF 25WV	
C936			CC73HCH1H100D	CHIP C 10PF D	
C938			CC73HCH1H100D	CHIP C 10PF D	
C939			CK73GB1C104K	CHIP C 0.10UF K	
C940			CK73FB1A106K	CHIP C 10UF K	
C941,942			CK73HB1H102K	CHIP C 1000PF K	
C943,944			CS77BA1E4R7M	CHIP TMTL 4.7UF 25WV	
C945			CK73GB1H103K	CHIP C 0.010UF K	
C946			CC73HCH1H101J	CHIP C 100PF J	
C947			CK73HB1A104K	CHIP C 0.10UF K	
C948			CC73HCH1H101J	CHIP C 100PF J	
C949-954			CK73GB1E105K	CHIP C 1.0UF K	
C955			CC73HCH1H101J	CHIP C 100PF J	
C956,957			CK73HB1E103K	CHIP C 0.010UF K	
C958			CK73HB1H102K	CHIP C 1000PF K	
C959,960			CK73HB1E103K	CHIP C 0.010UF K	
C961			CK73HBOJ105K	CHIP C 1.0UF K	
C962			CK73HB1A104K	CHIP C 0.10UF K	
C963			CC73HCH1H101J	CHIP C 100PF J	
C964			CK73GB1E105K	CHIP C 1.0UF K	
C965			CK73HB1A104K	CHIP C 0.10UF K	

PARTS LIST

DISPLAY UNIT (X54-3680-10)

Ref. No.	Address	New parts	Parts No.	Description	Desti-nation	Ref. No.	Address	New parts	Parts No.	Description	Desti-nation
C966,967			CK73HB1H102K	CHIP C 1000PF K		R953			RK73GB2A271J	CHIP R 270 J 1/10W	
CN901			E40-6559-05	FLAT CABLE CONNECTOR		R954			RK73GB2A470J	CHIP R 47 J 1/10W	
CN902			E41-2671-05	PIN ASSY		R955			RK73GB2A271J	CHIP R 270 J 1/10W	
CN905			E40-6557-05	FLAT CABLE CONNECTOR		R956			RK73GB2A101J	CHIP R 100 J 1/10W	
J901			E58-0522-05	MODULAR JACK		R957,958			RK73GB2A271J	CHIP R 270 J 1/10W	
-			J31-0551-05	COLLAR		R960			RK73HB1J000J	CHIP R 0.0 J 1/16W	
L901,902			L41-1095-39	SMALL FIXED INDUCTOR (1.0UH)		R962			RK73HB1J000J	CHIP R 0.0 J 1/16W	
L903-905			L92-0140-05	CHIP FERRITE		R963,964			RK73GB2A391J	CHIP R 390 J 1/10W	
L906			L92-0163-05	BEADS CORE		R965,966			RK73GB2A821J	CHIP R 820 J 1/10W	
L907			L92-0140-05	CHIP FERRITE		R967-974			RK73HB1J103J	CHIP R 10K J 1/16W	
L908			L92-0163-05	BEADS CORE		R976			RK73HB1J000J	CHIP R 0.0 J 1/16W	
X901			L77-1950-05	CRYSTAL RESONATOR (11.0592MHZ)		R977-979			RK73HB1J473J	CHIP R 47K J 1/16W	
CP907,908			RK75HA1JR00J	CHIP-COM 0.00 J 1/16W		R981,982			RK73HB1J103J	CHIP R 10K J 1/16W	
CP909			RK74HA1J104J	CHIP-COM 100K J 1/16W		R986			RK73HB1J103J	CHIP R 10K J 1/16W	
CP910			RK74HA1J101J	CHIP-COM 100 J 1/16W		R988			RK73HB1J473J	CHIP R 47K J 1/16W	
CP912			RK74HA1J101J	CHIP-COM 100 J 1/16W		R989			RK73HB1J474J	CHIP R 470K J 1/16W	
CP917			RK74HA1J104J	CHIP-COM 100K J 1/16W		R990			RK73HB1J472J	CHIP R 4.7K J 1/16W	
R900			RK73HB1J000J	CHIP R 0.0 J 1/16W		R991			RK73HB1J474J	CHIP R 470K J 1/16W	
R901			RK73GB2A000J	CHIP R 0.0 J 1/10W		R992			RK73HB1J000J	CHIP R 0.0 J 1/16W	
R902			RK73HB1J102J	CHIP R 1.0K J 1/16W		R996			RK73HB1J472J	CHIP R 4.7K J 1/16W	
R904			RK73HB1J101J	CHIP R 100 J 1/16W		R997			RK73GB2A000J	CHIP R 0.0 J 1/10W	
R905			RK73HB1J102J	CHIP R 1.0K J 1/16W		R998			RK73HB1J000J	CHIP R 0.0 J 1/16W	
R906			RK73HB1J331J	CHIP R 330 J 1/16W		R999			RK73HB1J101J	CHIP R 100 J 1/16W	
R907			RK73HB1J104J	CHIP R 100K J 1/16W		D901,902			AVRM16080MAAB	VARIATOR	
R908			RK73HB1J473J	CHIP R 47K J 1/16W		D903			02DZ18F-X	ZENER DIODE	
R909			RK73HB1J104J	CHIP R 100K J 1/16W		D904			AVRM16080MAAB	VARIATOR	
R911			RK73HB1J472J	CHIP R 4.7K J 1/16W		D906			MINISMD C020F	VARIATOR	
R912			RK73HB1J333J	CHIP R 33K J 1/16W		D907			02DZ18F-X	ZENER DIODE	
R913			RK73HB1J823J	CHIP R 82K J 1/16W		D908			HSC119	DIODE	
R914			RK73HB1J104J	CHIP R 100K J 1/16W		D910			1SS416	DIODE	
R915			RK73HB1J473J	CHIP R 47K J 1/16W		D911,912			HSC119	DIODE	
R916,917			RK73HB1J103J	CHIP R 10K J 1/16W		D913			DA204U	DIODE	
R918			RK73GB2A100J	CHIP R 10 J 1/10W		D937			1SS416	DIODE	
R919			RK73HB1J103J	CHIP R 10K J 1/16W		IC901			TC7W66FK-F	MOS-IC	
R920,921			RK73HB1J101J	CHIP R 100 J 1/16W		IC902			TC7S51FE(F)	MOS-IC	
R922-925			RK73HB1J102J	CHIP R 1.0K J 1/16W		IC903			XC6209B502PR	MOS-IC	
R926			RK73HB1J103J	CHIP R 10K J 1/16W		IC904			XC6204B332M	MOS-IC	
R927			RK73HB1J473J	CHIP R 47K J 1/16W		IC905			TC7SH126FU-F	MOS-IC	
R928			RK73HB1J103J	CHIP R 10K J 1/16W		IC906			LM2682MMX	MOS-IC	
R929			RK73HB1J474J	CHIP R 470K J 1/16W		IC907			TC7WH126FU-F	MOS-IC	
R930			RK73HB1J103J	CHIP R 10K J 1/16W		IC908			TC7SH08FU-F	MOS-IC	
R931			RK73FB2B561J	CHIP R 560 J 1/8W		IC909			LMC7101BIM5	MOS-IC	
R932			RK73FB2B471J	CHIP R 470 J 1/8W		IC910			TC74LCX245FK	MOS-IC	
R933			RK73HB1J101J	CHIP R 100 J 1/16W		IC911			30620SPGPU3C	MICRO CONTROL UNIT	
R934-937			RK73HB1J473J	CHIP R 47K J 1/16W		IC912			TC7WZ245FK-F	MOS-IC	
R938,939			RK73HB1J103J	CHIP R 10K J 1/16W		IC913	*		29AL16D7KCCB	ROM IC	
R940			RK73HB1J274J	CHIP R 270K J 1/16W		Q901			SSM3K15TE(F)	FET	
R941			RK73HB1J124J	CHIP R 120K J 1/16W		Q902			RT1N441U-T111	TRANSISTOR	
R942			RK73HB1J000J	CHIP R 0.0 J 1/16W		Q904			RT1N441U-T111	TRANSISTOR	
R943			RK73HB1J102J	CHIP R 1.0K J 1/16W		Q905,906			RT1N141U-T111	TRANSISTOR	
R944			RK73HB1J104J	CHIP R 100K J 1/16W		Q908,909			RT1N141U-T111	TRANSISTOR	
R945,946			RK73HB1J000J	CHIP R 0.0 J 1/16W		Q910			12A02CH	TRANSISTOR	
R947			RK73HB1J474J	CHIP R 470K J 1/16W		Q911			SSM3K15TE(F)	FET	
R948			RK73HB1J103J	CHIP R 10K J 1/16W		Q913			UPA672T-A	FET	
R949			RK73HB1J102J	CHIP R 1.0K J 1/16W		TH901			ERTJ0EV104H	THERMISTOR	
R950			RK73HB1J473J	CHIP R 47K J 1/16W							
R952			RK73HB1J000J	CHIP R 0.0 J 1/16W							

PARTS LIST

TX-RX UNIT (X57-7750-18)

Ref. No.	Address	New parts	Parts No.	Description	Destination	Ref. No.	Address	New parts	Parts No.	Description	Destination	
TX-RX UNIT (X57-7750-18)						C80			CK73HB1H471K	CHIP C	470PF	K
C1			CK73HB0J105K	CHIP C	1.0UF	K	C81		CC73HCH1H100B	CHIP C	10PF	B
C2			CC73HCH1H101J	CHIP C	100PF	J	C82		CC73HCH1H330J	CHIP C	33PF	J
C3			CK73HB1H471K	CHIP C	470PF	K	C83,84		CK73HB1H471K	CHIP C	470PF	K
C4			CK73HB1A104K	CHIP C	0.10UF	K	C85		CK73HB1A104K	CHIP C	0.10UF	K
C5			CK73HB1E103K	CHIP C	0.010UF	K	C86		CC73HCH1H070B	CHIP C	7.0PF	B
C6			CC73HCH1H101J	CHIP C	100PF	J	C88		CK73HB1E103K	CHIP C	0.010UF	K
C7			CC73HCH1H180J	CHIP C	18PF	J	C90-92		CK73HB1E103K	CHIP C	0.010UF	K
C8			CC73HCH1H120G	CHIP C	12PF	G	C98		CK73HB1H471K	CHIP C	470PF	K
C9			CK73HB1E103K	CHIP C	0.010UF	K	C101,102		CK73HB1H471K	CHIP C	470PF	K
C10			CC73HCH1H390J	CHIP C	39PF	J	C103		CK73HB1E103K	CHIP C	0.010UF	K
C11			CK73FB1A106K	CHIP C	10UF	K	C104-107		CK73HB1H471K	CHIP C	470PF	K
C12			CC73HCH1H120G	CHIP C	12PF	G	C108		CK73FB1E475K	CHIP C	4.7UF	K
C13			CK73HB1E103K	CHIP C	0.010UF	K	C109		CC73HCH1H090B	CHIP C	9.0PF	B
C14			CK73GB1E105K	CHIP C	1.0UF	K	C110-112		CK73HB1H471K	CHIP C	470PF	K
C15			CC73HCH1H101J	CHIP C	100PF	J	C115-117		CK73HB1H471K	CHIP C	470PF	K
C16,17			CK73HB1E103K	CHIP C	0.010UF	K	C118		CC73HCH1H100B	CHIP C	10PF	B
C18-23			CC73HCH1H101J	CHIP C	100PF	J	C119		CC73HCH1H080B	CHIP C	8.0PF	B
C24			CK73HB1A104K	CHIP C	0.10UF	K	C120		CK73HB1H471K	CHIP C	470PF	K
C25,26			CC73HCH1H101J	CHIP C	100PF	J	C121		CC73HCH1H020B	CHIP C	2.0PF	B
C27			CK73HB1A104K	CHIP C	0.10UF	K	C122		CC73HCH1H080B	CHIP C	8.0PF	B
C28,29			CC73HCH1H101J	CHIP C	100PF	J	C123		CC73HCH1H220J	CHIP C	22PF	J
C31			CC73HCH1H101J	CHIP C	100PF	J	C125		CK73HB1H471K	CHIP C	470PF	K
C32			CS77CA1VR15M	CHIP TNTL	0.15UF	35WV	C127		CK73HB1H471K	CHIP C	470PF	K
C33			CC73HCH1H330J	CHIP C	33PF	J	C128		CC73HCH1H470J	CHIP C	47PF	J
C34			CC73HCH1H470J	CHIP C	47PF	J	C131		CC73HCH1H101J	CHIP C	100PF	J
C35			CS77BA1D100M	CHIP TNTL	10UF	20WV	C132		CK73HB1H471K	CHIP C	470PF	K
C36			CC73HCH1H080B	CHIP C	8.0PF	B	C133		CC73HCH1H220J	CHIP C	22PF	J
C37			C92-0863-05	CHIP TNTL	0.047UF	35WV	C134		CK73HB1H471K	CHIP C	470PF	K
C38			C93-0787-05	CERAMIC	0.1UF	50WV	C135		CC73HCH1H101J	CHIP C	100PF	J
C39			CC73HCH1H030B	CHIP C	3.0PF	B	C136		CK73FB1H471K	CHIP C	470PF	K
C41			CK73HB1H471K	CHIP C	470PF	K	C138		CS77CA1A6R8M	CHIP TNTL	6.8UF	10WV
C43			CK73HB1H471K	CHIP C	470PF	K	C141		CC73HCH1H220J	CHIP C	22PF	J
C44,45			CC73HCH1H101J	CHIP C	100PF	J	C142		CC73HCH1H470J	CHIP C	47PF	J
C46			CC73HCH1H080B	CHIP C	8.0PF	B	C145		CC73HCH1H101J	CHIP C	100PF	J
C47			CC73HCH1H470J	CHIP C	47PF	J	C147		CK73HB1H471K	CHIP C	470PF	K
C48			CK73HB0J105K	CHIP C	1.0UF	K	C150		C92-0875-05	ELECTRO	1000UF	25WV
C49			CC73HCH1H180G	CHIP C	18PF	G	C152,153		CC73HCH1H101J	CHIP C	100PF	J
C50,51			CC73HCH1H151J	CHIP C	150PF	J	C155,156		CC73HCH1H220J	CHIP C	22PF	J
C52,53			CK73HB1H471K	CHIP C	470PF	K	C157		CC73HCH1H101J	CHIP C	100PF	J
C54			CK73HB1A104K	CHIP C	0.10UF	K	C158		CK73HB1H471K	CHIP C	470PF	K
C55			CK73HB0J105K	CHIP C	1.0UF	K	C162		CC73FCH1H150G	CHIP C	15PF	G
C56			CK73HB1H471K	CHIP C	470PF	K	C164		CC73GCH1H0R5B	CHIP C	0.5PF	B
C58			CC73HCH1H270G	CHIP C	27PF	G	C165		CC73GCH1H010B	CHIP C	1.0PF	B
C59			CC73HCH1H470G	CHIP C	47PF	G	C166		CC73HCH1H101J	CHIP C	100PF	J
C63			CC73HCH1HR75B	CHIP C	0.75PF	B	C169		CK73HB1H471K	CHIP C	470PF	K
C64			CC73HCH1H090B	CHIP C	9.0PF	B	C170		CC73GCH1H0R5B	CHIP C	0.5PF	B
C65			CK73FB1A106K	CHIP C	10UF	K	C171		CC73GCH1H010B	CHIP C	1.0PF	B
C66,67			CC73HCH1H070B	CHIP C	7.0PF	B	C172		CC73HCH1H101J	CHIP C	100PF	J
C68,69			CC73HCH1H060B	CHIP C	6.0PF	B	C174		C93-0550-05	CHIP C	1.0PF	C
C70			CK73HB1H471K	CHIP C	470PF	K	C175		CK73HB1H471K	CHIP C	470PF	K
C71			CK73GB1E105K	CHIP C	1.0UF	K	C178		CC73GCH1H0R5B	CHIP C	0.5PF	B
C72			CC73HCH1H050B	CHIP C	5.0PF	B	C179		CC73GCH1H040B	CHIP C	4.0PF	B
C73			CK73HB1H471K	CHIP C	470PF	K	C180		CC73HCH1H101J	CHIP C	100PF	J
C74			CC73HCH1H0R5B	CHIP C	0.5PF	B	C181		CK73HB1H471K	CHIP C	470PF	K
C75			CK73HB1H471K	CHIP C	470PF	K	C185		CM73F2H120J	CHIP C	12PF	J
C76			CC73HCH1H0R5B	CHIP C	0.5PF	B	C186		CM73F2H121J	CHIP C	120PF	J
C77,78			CK73HB1H471K	CHIP C	470PF	K	C187		CM73F2H020C	CHIP C	2.0PF	C
C79			CC73HCH1H070B	CHIP C	7.0PF	B	C188,189		CM73F2H150J	CHIP C	15PF	J
							C190		CM73F2H070D	CHIP C	7.0PF	D

PARTS LIST

TX-RX UNIT (X57-7750-18)

Ref. No.	Address	New parts	Parts No.	Description	Destination	Ref. No.	Address	New parts	Parts No.	Description	Destination
C194			CK73HB1H471K	CHIP C 470PF K		C292			CK73HB1H471K	CHIP C 470PF K	
C201			CK73HB1E103K	CHIP C 0.010UF K		C293			CC73HCH1H120G	CHIP C 12PF G	
C202-205			CK73HB1A104K	CHIP C 0.10UF K		C294			CK73HB1H471K	CHIP C 470PF K	
C206			CC73HCH1H100B	CHIP C 10PF B		C295			CC73HCH1H560J	CHIP C 56PF J	
C207,208			CK73HB1E103K	CHIP C 0.010UF K		C296			CC73HCH1H070B	CHIP C 7.0PF B	
C210			CK73HB1A104K	CHIP C 0.10UF K		C297			CC73HCH1H090B	CHIP C 9.0PF B	
C211			CC73HCH1H100B	CHIP C 10PF B		C298			CK73HB1H471K	CHIP C 470PF K	
C212,213			CK73HB1A104K	CHIP C 0.10UF K		C299			CC73HCH1H560J	CHIP C 56PF J	
C214			CC73HCH1H680J	CHIP C 68PF J		C301			CC73HCH1H050B	CHIP C 5.0PF B	
C215			CC73HCH1H101J	CHIP C 100PF J		C302			CK73GB1H104K	CHIP C 0.10UF K	
C216			CC73HCH1H680J	CHIP C 68PF J		C307,308			CK73HB1H471K	CHIP C 470PF K	
C217			CK73HB1A104K	CHIP C 0.10UF K		C315			CC73HCH1H060B	CHIP C 6.0PF B	
C218,219			CK73GB0J475K	CHIP C 4.7UF K		C316			CK73HB1H471K	CHIP C 470PF K	
C220			CC73HCH1H470J	CHIP C 47PF J		C317			CC73HCH1H270G	CHIP C 27PF G	
C221			CK73FB1A106K	CHIP C 10UF K		C318,319			CC73HCH1H030B	CHIP C 3.0PF B	
C222-224			CK73HB1E103K	CHIP C 0.010UF K		C320			CK73HB1H471K	CHIP C 470PF K	
C225			CK73HB1A104K	CHIP C 0.10UF K		C321			CC73HCH1H090B	CHIP C 9.0PF B	
C226			CK73FB1A106K	CHIP C 10UF K		C322			CC73HCH1H330G	CHIP C 33PF G	
C227			CC73HCH1H820J	CHIP C 82PF J		C323			CC73HCH1H050B	CHIP C 5.0PF B	
C228-230			CK73HB1A104K	CHIP C 0.10UF K		C324			CC73HCH1H060B	CHIP C 6.0PF B	
C231			CK73HB1E103K	CHIP C 0.010UF K		C326			CC73GCH1H471J	CHIP C 470PF J	
C232			CK73HB1A104K	CHIP C 0.10UF K		C327			CK73HB1H471K	CHIP C 470PF K	
C233			CK73HB0J105K	CHIP C 1.0UF K		C330-334			CK73HB1A104K	CHIP C 0.10UF K	
C234			CK73HB1E103K	CHIP C 0.010UF K		C335			CC73HCH1H470G	CHIP C 47PF G	
C236			CC73HCH1H470J	CHIP C 47PF J		C336			CK73HB1E103K	CHIP C 0.010UF K	
C237			CK73HB1H471K	CHIP C 470PF K		C337,338			CK73HB1A104K	CHIP C 0.10UF K	
C238-240			CK73HB1E103K	CHIP C 0.010UF K		C339			CK73HB1E103K	CHIP C 0.010UF K	
C242			CK73HB1H471K	CHIP C 470PF K		C341			CK73HB0J105K	CHIP C 1.0UF K	
C243			CK73HB1E103K	CHIP C 0.010UF K		C342			CK73FB1A106K	CHIP C 10UF K	
C244			CC73HCH1H470J	CHIP C 47PF J		C343			CK73HB1A104K	CHIP C 0.10UF K	
C245			CK73HB1H471K	CHIP C 470PF K		C344			CC73HCH1H101J	CHIP C 100PF J	
C246			CK73HB1E103K	CHIP C 0.010UF K		C347			CK73HB1H471K	CHIP C 470PF K	
C247			CK73HB1A104K	CHIP C 0.10UF K		C348			CK73HB1E103K	CHIP C 0.010UF K	
C252			CC73HCH1H010B	CHIP C 1.0PF B		C358			CK73HB1H182K	CHIP C 1800PF K	
C256			CC73HCH1H010B	CHIP C 1.0PF B		C361			CC73HCH1H101J	CHIP C 100PF J	
C257			CK73HB1H471K	CHIP C 470PF K		C364-366			CK73HB1H102K	CHIP C 1000PF K	
C260			CK73HB1E103K	CHIP C 0.010UF K		C401			C92-0777-05	ELECTRO 1000UF 25WV	
C261			CC73HCH1H101J	CHIP C 100PF J		C403			CK73HB1H471K	CHIP C 470PF K	
C262			CK73HB1E103K	CHIP C 0.010UF K		C405			CK73HB1H471K	CHIP C 470PF K	
C263,264			CK73HB1H471K	CHIP C 470PF K		C406			CK73HB1H102K	CHIP C 1000PF K	
C265			CK73HB1E103K	CHIP C 0.010UF K		C409			CK73HB1E103K	CHIP C 0.010UF K	
C266			CK73HB1H102K	CHIP C 1000PF K		C410			CK73GB1H103K	CHIP C 0.010UF K	
C267			CC73HCH1H120G	CHIP C 12PF G		C411			CK73HB1H471K	CHIP C 470PF K	
C268			CK73HB1E103K	CHIP C 0.010UF K		C413			CK73GB1E105K	CHIP C 1.0UF K	
C269,270			CK73HB1H471K	CHIP C 470PF K		C415			CK73HB1H471K	CHIP C 470PF K	
C271			CC73HCH1H120G	CHIP C 12PF G		C417			CK73HB1H471K	CHIP C 470PF K	
C272			CC73HCH1H020B	CHIP C 2.0PF B		C419			CK73HB1H102K	CHIP C 1000PF K	
C273			CC73HCH1H120G	CHIP C 12PF G		C420			CK73HB1A104K	CHIP C 0.10UF K	
C275			CC73HCH1H030B	CHIP C 3.0PF B		C421			CK73GB1H473K	CHIP C 0.047UF K	
C276			CC73HCH1H060B	CHIP C 6.0PF B		C422			CK73FB1E475K	CHIP C 4.7UF K	
C278-281			CK73HB1H471K	CHIP C 470PF K		C424			CK73GB1E105K	CHIP C 1.0UF K	
C283			CC73HCH1H100B	CHIP C 10PF B		C425			CK73GB1H104K	CHIP C 0.10UF K	
C284			CK73HB1H471K	CHIP C 470PF K		C426			CK73HB1E103K	CHIP C 0.010UF K	
C285			CC73HCH1H560J	CHIP C 56PF J		C427			CK73HB1H471K	CHIP C 470PF K	
C286			CC73HCH1H080B	CHIP C 8.0PF B		C428			CC73HCH1H101J	CHIP C 100PF J	
C287			CC73HCH1H050B	CHIP C 5.0PF B		C429			CK73GB1H104K	CHIP C 0.10UF K	
C288			CK73HB1H471K	CHIP C 470PF K		C430,431			CK73FB1E475K	CHIP C 4.7UF K	
C289			CK73GB1H104K	CHIP C 0.10UF K		C432			C92-0875-05	ELECTRO 47UF 25WV	
C290			CC73HCH1H560J	CHIP C 56PF J		C433			CK73GB1H104K	CHIP C 0.10UF K	
C291			CC73HCH1H090B	CHIP C 9.0PF B		C434			CK73HB1H102K	CHIP C 1000PF K	

PARTS LIST

TX-RX UNIT (X57-7750-18)

Ref. No.	Address	New parts	Parts No.	Description	Destination	Ref. No.	Address	New parts	Parts No.	Description	Destination
C435			CK73FB1A106K	CHIP C 10UF K		C551			CK73HB1E103K	CHIP C 0.010UF K	
C436			CS77BA1A100M	CHIP TNTL 10UF 10WV		C552			CK73HBOJ105K	CHIP C 1.0UF K	
C437			CK73HB1A224K	CHIP C 0.22UF K		C553			CC73HCH1H101J	CHIP C 100PF J	
C438			CK73FB1A106K	CHIP C 10UF K		C554-558			CK73HB1A104K	CHIP C 0.10UF K	
C439			CK73HB1E103K	CHIP C 0.010UF K		C559			CK73HB1E103K	CHIP C 0.010UF K	
C440			CK73GB1E105K	CHIP C 1.0UF K		C560			CK73HBOJ105K	CHIP C 1.0UF K	
C441,442			CK73HB1E103K	CHIP C 0.010UF K		C561-563			CC73HCH1H101J	CHIP C 100PF J	
C443,444			CK73GB1E105K	CHIP C 1.0UF K		C565,566			CC73HCH1H101J	CHIP C 100PF J	
C445			CK73FB1A106K	CHIP C 10UF K		C567			CK73HB1H102K	CHIP C 1000PF K	
C446			C92-0765-05	CHIP TNTL 4.7UF 16WV		C568-578			CC73HCH1H101J	CHIP C 100PF J	
C447			CK73HB1A224K	CHIP C 0.22UF K		C579			CK73HB1H102K	CHIP C 1000PF K	
C448			CK73HB1E103K	CHIP C 0.010UF K		C580			CC73HCH1H101J	CHIP C 100PF J	
C449			CK73GB1C225K	CHIP C 2.2UF K		C581-583			CK73HB1H102K	CHIP C 1000PF K	
C450			CK73HB1E103K	CHIP C 0.010UF K		C584,585			CC73HCH1H101J	CHIP C 100PF J	
C451			CK73GB1C225K	CHIP C 2.2UF K		C586			CK73HB1E103K	CHIP C 0.010UF K	
C452			CK73HBOJ105K	CHIP C 1.0UF K		C587-589			CK73HB1H102K	CHIP C 1000PF K	
C453			CK73GB1E105K	CHIP C 1.0UF K		C590,591			CK73HB1E103K	CHIP C 0.010UF K	
C454			CK73HB1H471K	CHIP C 470PF K		C592,593			CC73HCH1H101J	CHIP C 100PF J	
C455,456			CK73HB1E103K	CHIP C 0.010UF K		C594,595			CK73HB1E103K	CHIP C 0.010UF K	
C457,458			CK73GB1E105K	CHIP C 1.0UF K		C596			CK73HB1A104K	CHIP C 0.10UF K	
C459			C92-0765-05	CHIP TNTL 4.7UF 16WV		C597-607			CK73HB1H102K	CHIP C 1000PF K	
C460			CK73HB1A104K	CHIP C 0.10UF K		C608			CC73HCH1H101J	CHIP C 100PF J	
C461			CC73HCH1H181J	CHIP C 180PF J		C609			CK73HB1H102K	CHIP C 1000PF K	
C462			CK73HB1H471K	CHIP C 470PF K		C610			CC73HCH1H101J	CHIP C 100PF J	
C463			CK73HBOJ105K	CHIP C 1.0UF K		C611			CK73HB1H102K	CHIP C 1000PF K	
C464			CC73HCH1H220J	CHIP C 22PF J		C612			CK73GB1H103K	CHIP C 0.010UF K	
C465-467			CK73GB1E105K	CHIP C 1.0UF K		C613-616			CK73GB1E105K	CHIP C 1.0UF K	
C468			CK73HB1E103K	CHIP C 0.010UF K		C618			CK73HB1E103K	CHIP C 0.010UF K	
C471			CK73HBOJ105K	CHIP C 1.0UF K		C620,621			CK73HB1E103K	CHIP C 0.010UF K	
C473			CS77BA1E4R7M	CHIP TNTL 4.7UF 25WV		C622			CK73HB1H102K	CHIP C 1000PF K	
C474			CK73HB1E103K	CHIP C 0.010UF K		C623-629			CK73HB1E103K	CHIP C 0.010UF K	
C475			CK73FB1A106K	CHIP C 10UF K		C630			CK73GB1H104K	CHIP C 0.10UF K	
C476			CK73HB1H102K	CHIP C 1000PF K		C702			CK73HBOJ105K	CHIP C 1.0UF K	
C477			CC73HCH1H101J	CHIP C 100PF J		C704			CC73HCH1H030B	CHIP C 3.0PF B	
C478-483			CK73HB1H102K	CHIP C 1000PF K		C705			CK73HB1H122K	CHIP C 1200PF K	
C501,502			CK73HBOJ105K	CHIP C 1.0UF K		C706			CK73HB1H331K	CHIP C 330PF K	
C503-507			CK73HB1A104K	CHIP C 0.10UF K		C707			CK73HB1A104K	CHIP C 0.10UF K	
C508			CK73HB1H102K	CHIP C 1000PF K		C708			CK73HB1H122K	CHIP C 1200PF K	
C509			CK73HB1A104K	CHIP C 0.10UF K		C709			CC73HCH1H221J	CHIP C 220PF J	
C511-514			CK73HB1A104K	CHIP C 0.10UF K		C710			CK73HB1E103K	CHIP C 0.010UF K	
C515			CK73HBOJ105K	CHIP C 1.0UF K		C711			CC73HCH1H181J	CHIP C 180PF J	
C516,517			CK73HB1A104K	CHIP C 0.10UF K		C712			CC73HCH1H680J	CHIP C 68PF J	
C518			CK73GB1E105K	CHIP C 1.0UF K		C714			CK73HB1E103K	CHIP C 0.010UF K	
C520-523			CK73HB1E103K	CHIP C 0.010UF K		C715			CK73HB1H122K	CHIP C 1200PF K	
C527			CK73HB1E103K	CHIP C 0.010UF K		C716			CC73HCH1H221J	CHIP C 220PF J	
C528			CK73HB1A104K	CHIP C 0.10UF K		C717			CK73HB1A104K	CHIP C 0.10UF K	
C529,530			CK73HB1E103K	CHIP C 0.010UF K		C718			CC73HCH1H221J	CHIP C 220PF J	
C531			CK73HB1A104K	CHIP C 0.10UF K		C719,720			CK73HB1A104K	CHIP C 0.10UF K	
C532			CK73HB1E103K	CHIP C 0.010UF K		C721			CC73HCH1H221J	CHIP C 220PF J	
C533			CK73HB1A104K	CHIP C 0.10UF K		C722			CC73HCH1H470J	CHIP C 47PF J	
C534			CC73HCH1H101J	CHIP C 100PF J		C723,724			CK73HB1A104K	CHIP C 0.10UF K	
C535			CS77CP0J100M	CHIP TNTL 10UF 6.3WV		C725			CK73HB1E103K	CHIP C 0.010UF K	
C536			CK73HB1E103K	CHIP C 0.010UF K		C726			CK73HB1A104K	CHIP C 0.10UF K	
C537,538			CK73HB1A104K	CHIP C 0.10UF K		C727			CC73HCH1H820J	CHIP C 82PF J	
C539			CK73HB1E103K	CHIP C 0.010UF K		C729			CK73HB1A104K	CHIP C 0.10UF K	
C540			CK73HBOJ105K	CHIP C 1.0UF K		C730			CK73HB1H561K	CHIP C 560PF K	
C541			CK73HB1A104K	CHIP C 0.10UF K		C731			CK73HB1A104K	CHIP C 0.10UF K	
C542			CS77CP0J100M	CHIP TNTL 10UF 6.3WV		C732			CK73HB1E103K	CHIP C 0.010UF K	
C543-546			CC73HCH1H101J	CHIP C 100PF J		C734			CK73HB1E103K	CHIP C 0.010UF K	
C547-550			CK73HB1A104K	CHIP C 0.10UF K		C735			CK73FB1E475K	CHIP C 4.7UF K	

PARTS LIST

TX-RX UNIT (X57-7750-18)

Ref. No.	Address	New parts	Parts No.	Description	Destination	Ref. No.	Address	New parts	Parts No.	Description	Destination
C736			CC73HCH1H101J	CHIP C 100PF J		C922,923			CK73HB1H102K	CHIP C 1000PF K	
C737			CK73HB1A104K	CHIP C 0.10UF K		CN401,402			E23-1260-04	TERMINAL	
C738			CK73HB1H102K	CHIP C 1000PF K		CN403			E41-1682-05	PIN ASSY	
C740			CK73HB1H472K	CHIP C 4700PF K		CN502-513			E23-1278-05	TERMINAL	
C741			CK73HB1A154K	CHIP C 0.15UF K		CN516,517			E23-1278-05	TERMINAL	
						CN520			E23-1278-05	TERMINAL	
C742			CK73HB1A104K	CHIP C 0.10UF K		CN527			E23-1278-05	TERMINAL	
C743			CK73HB1E103K	CHIP C 0.010UF K		CN540			E23-1278-05	TERMINAL	
C744			CK73HB1A104K	CHIP C 0.10UF K		CN542,543			E23-1278-05	TERMINAL	
C745-747			CK73HB1E103K	CHIP C 0.010UF K		CN549			E40-6720-05	SOCKET FOR PIN ASSY	
C748-751			CK73HB1A104K	CHIP C 0.10UF K		CN595			E40-6361-05	PIN ASSY	
C752,753			CK73HB1E103K	CHIP C 0.010UF K		CN597			E40-6558-05	FLAT CABLE CONNECTOR	
C754			CK73HB1H102K	CHIP C 1000PF K		CN600			E40-6560-05	FLAT CABLE CONNECTOR	
C757			CC73HCH1H150J	CHIP C 15PF J		CN611,612			E23-1278-05	TERMINAL	
C761			CK73HB1E103K	CHIP C 0.010UF K		CN614			E23-1278-05	TERMINAL	
C762,763			CK73HB1A104K	CHIP C 0.10UF K		CN705			E40-6582-05	PIN ASSY	
C764			CC73HCH1H220J	CHIP C 22PF J		CN901			E40-6560-05	FLAT CABLE CONNECTOR	
C765,766			CK73GB1E105K	CHIP C 1.0UF K		J701			E11-0425-05	3.5D PHONE JACK (3P)	
C767			CK73HB1A104K	CHIP C 0.10UF K		J901			E58-0521-05	SUB SOCKET (D)	
C768,769			CK73HB1E103K	CHIP C 0.010UF K							
C770			CK73HB1A104K	CHIP C 0.10UF K		F401			F53-0328-05	FUSE	
C773			CK73HB1A104K	CHIP C 0.10UF K		F501			F53-0352-05	FUSE	
C774			CK73HB1H102K	CHIP C 1000PF K		CN405			J19-5386-05	HOLDER	
C775			CK73HB1A104K	CHIP C 0.10UF K		CD201			L79-1850-05	TUNING COIL	
C776			CK73HBQJ105K	CHIP C 1.0UF K		CF201			L72-1027-05	CERAMIC FILTER	
C777			CK73HB1H102K	CHIP C 1000PF K		CF202			L72-1041-05	CERAMIC FILTER	
C778			CK73HB1A104K	CHIP C 0.10UF K		CF203			L72-1020-05	CERAMIC FILTER	
C779			CC73HCH1H680J	CHIP C 68PF J		L1			L41-4795-39	SMALL FIXED INDUCTOR (4.7UH)	
C782-786			CK73HB1A104K	CHIP C 0.10UF K		L3			L92-0163-05	BEADS CORE	
C787			CK73FB1A106K	CHIP C 10UF K		L4			L40-1875-92	SMALL FIXED INDUCTOR (18NH)	
C788			CK73HB1A104K	CHIP C 0.10UF K		L6,7			L40-1001-86	SMALL FIXED INDUCTOR (10UH)	
C789			CK73FB1E475K	CHIP C 4.7UF K		L10			L40-4775-92	SMALL FIXED INDUCTOR (47NH)	
C790			CK73FB1A106K	CHIP C 10UF K		L11-16			L40-2285-92	SMALL FIXED INDUCTOR (220NH)	
C791			CK73HB1H102K	CHIP C 1000PF K		L17			L34-4609-15	AIR-CORE COIL	
C792			CC73HCH1H470J	CHIP C 47PF J		L18			L34-4610-15	AIR-CORE COIL	
C793			CK73HB1H102K	CHIP C 1000PF K		L19			L40-2285-92	SMALL FIXED INDUCTOR (220NH)	
C794,795			CK73FB1A106K	CHIP C 10UF K		L20			L92-0446-05	BEADS CORE	
C796-799			CK73HB1A104K	CHIP C 0.10UF K		L21-23			L40-2285-92	SMALL FIXED INDUCTOR (220NH)	
C801,802			CK73GB1E105K	CHIP C 1.0UF K		L25			L40-2775-71	SMALL FIXED INDUCTOR (27NH)	
C803-805			CK73HB1H102K	CHIP C 1000PF K		L26			L40-3975-92	SMALL FIXED INDUCTOR (39NH)	
C806			C92-0906-05	ELECTRO 330UF 25WV		L31-36			L92-0163-05	BEADS CORE	
C807			C92-0875-05	ELECTRO 47UF 25WV		L40,41			L92-0163-05	BEADS CORE	
C809			CK73HB1H102K	CHIP C 1000PF K		L101			L40-2275-92	SMALL FIXED INDUCTOR (22NH)	
C810			CK73HB1H471K	CHIP C 470PF K		L102			L92-0140-05	CHIP FERRITE	
C811			CK73HB1H102K	CHIP C 1000PF K		L103			L40-2275-92	SMALL FIXED INDUCTOR (22NH)	
C813			CK73FB1A106K	CHIP C 10UF K		L104			L40-1875-92	SMALL FIXED INDUCTOR (18NH)	
C814			CK73HB1H471K	CHIP C 470PF K		L106			L92-0140-05	CHIP FERRITE	
C815,816			CK73FB1A106K	CHIP C 10UF K		L107-109			L92-0179-05	CHIP FERRITE	
C817			CK73HB1E103K	CHIP C 0.010UF K		L110			L34-4638-05	AIR-CORE COIL	
C818			CK73HBQJ105K	CHIP C 1.0UF K		L111-114			L34-4758-05	AIR-CORE COIL	
C820			CK73GB1E105K	CHIP C 1.0UF K		L115			L34-4848-05	AIR-CORE COIL	
C821			CK73HB1H102K	CHIP C 1000PF K		L117-119			L92-0163-05	BEADS CORE	
C824			CK73HB1H102K	CHIP C 1000PF K		L201			L40-1085-71	SMALL FIXED INDUCTOR (100NH)	
C825			CC73HCH1H101J	CHIP C 100PF J		L202			L40-5681-86	SMALL FIXED INDUCTOR (0.56UH)	
C826			CK73HB1H102K	CHIP C 1000PF K		L204			L41-4778-45	SMALL FIXED INDUCTOR (47NH)	
C828			CC73HCH1H101J	CHIP C 100PF J		L205			L40-5681-86	SMALL FIXED INDUCTOR (0.56UH)	
C901			CC73HCH1H101J	CHIP C 100PF J		L206			L92-0138-05	CHIP FERRITE	
C902			CK73HB1H102K	CHIP C 1000PF K		L207			L40-5681-86	SMALL FIXED INDUCTOR (0.56UH)	
C903-906			CC73HCH1H101J	CHIP C 100PF J							
C907			CK73HB1H102K	CHIP C 1000PF K							
C908-921			CC73HCH1H101J	CHIP C 100PF J							

NX-800H

PARTS LIST

TX-RX UNIT (X57-7750-18)

Ref. No.	Address	New parts	Parts No.	Description	Destination	Ref. No.	Address	New parts	Parts No.	Description	Destination
L208			L92-0138-05	CHIP FERRITE		R46			RK73HB1J271J	CHIP R 270 J 1/16W	
L209			L40-3975-92	SMALL FIXED INDUCTOR (39NH)		R47			RK73HB1J224J	CHIP R 220K J 1/16W	
L210			L39-1498-05	TOROIDAL COIL		R49			RK73HB1J683J	CHIP R 68K J 1/16W	
L211			L92-0138-05	CHIP FERRITE		R53,54			RK73HB1J473J	CHIP R 47K J 1/16W	
L212			L39-1498-05	TOROIDAL COIL		R55			RK73HB1J472J	CHIP R 4.7K J 1/16W	
L213			L40-3375-92	SMALL FIXED INDUCTOR (33NH)		R56			RK73HB1J474J	CHIP R 470K J 1/16W	
L214			L40-2775-92	SMALL FIXED INDUCTOR (27NH)		R57			RK73HB1J181D	CHIP R 180 D 1/16W	
L215			L39-1498-05	TOROIDAL COIL		R58			RK73HB1J181J	CHIP R 180 J 1/16W	
L216-219			L34-4566-05	AIR-CORE COIL		R59			RK73HB1J181D	CHIP R 180 D 1/16W	
L221			L41-2278-14	SMALL FIXED INDUCTOR (22NH)		R60			RK73HB1J102J	CHIP R 1.0K J 1/16W	
L223,224			L34-4569-05	AIR-CORE COIL		R61			RK73HB1J473J	CHIP R 47K J 1/16W	
L225			L41-1878-14	SMALL FIXED INDUCTOR (18NH)		R62			RK73HB1J154J	CHIP R 150K J 1/16W	
L229			L40-1875-71	SMALL FIXED INDUCTOR (18NH)		R63			RK73HB1J101J	CHIP R 100 J 1/16W	
L230			L92-0138-05	CHIP FERRITE		R64			RK73HB1J682J	CHIP R 6.8K J 1/16W	
L401-403			L92-0179-05	CHIP FERRITE		R65			RK73HB1J103J	CHIP R 10K J 1/16W	
L404			L92-0639-05	CHIP FERRITE		R66			RK73HB1J331J	CHIP R 330 J 1/16W	
L405			L33-1496-05	SMALL FIXED INDUCTOR		R67			RK73HB1J222J	CHIP R 2.2K J 1/16W	
L406			L33-1462-05	SMALL FIXED INDUCTOR		R68			RK73HB1J470J	CHIP R 47 J 1/16W	
L501-503			L92-0138-05	CHIP FERRITE		R69			RK73HB1J000J	CHIP R 0.0 J 1/16W	
L506-511			L92-0138-05	CHIP FERRITE		R70			RK73HB1J472J	CHIP R 4.7K J 1/16W	
L512			L92-0140-05	CHIP FERRITE		R71			RK73HB1J474J	CHIP R 470K J 1/16W	
L517,518			L92-0138-05	CHIP FERRITE		R72			RK73HB1J183J	CHIP R 18K J 1/16W	
L521-523			L92-0162-05	BEADS CORE		R74			RK73HB1J102J	CHIP R 1.0K J 1/16W	
L901,902			L92-0140-05	CHIP FERRITE		R75			RK73HB1J221J	CHIP R 220 J 1/16W	
L903-905			L92-0162-05	BEADS CORE		R76			RK73HB1J474J	CHIP R 470K J 1/16W	
X1			L77-3016-05	TCXO (19.2MHZ)		R77			RK73HB1J101J	CHIP R 100 J 1/16W	
X501			L77-1802-05	CRYSTAL RESONATOR (32.768KHZ)		R79-83			RK73HB1J000J	CHIP R 0.0 J 1/16W	
X502			L77-3015-05	TCXO (18.432MHZ)		R84,85			RK73GB2A000J	CHIP R 0.0 J 1/10W	
XF202			L71-0649-05	MCF (58.05MHZ)		R86			RK73GB2A272J	CHIP R 2.7K J 1/10W	
R1,2			RK73HB1J223D	CHIP R 22K D 1/16W		R101			RK73HB1J332J	CHIP R 3.3K J 1/16W	
R3			RK73HB1J334J	CHIP R 330K J 1/16W		R102			RK73HB1J271J	CHIP R 270 J 1/16W	
R4			RK73HB1J101J	CHIP R 100 J 1/16W		R103			RK73HB1J180J	CHIP R 18 J 1/16W	
R5			RK73HB1J224J	CHIP R 220K J 1/16W		R104			RK73HB1J271J	CHIP R 270 J 1/16W	
R6			RK73HB1J472J	CHIP R 4.7K J 1/16W		R105			RK73HB1J333J	CHIP R 33K J 1/16W	
R7			RK73HB1J103J	CHIP R 10K J 1/16W		R106			RK73HB1J471J	CHIP R 470 J 1/16W	
R8			RK73HB1J472J	CHIP R 4.7K J 1/16W		R107			RK73HB1J682J	CHIP R 6.8K J 1/16W	
R10			RK73HB1J000J	CHIP R 0.0 J 1/16W		R108			RK73GB2A100J	CHIP R 10 J 1/10W	
R12			RK73HB1J472J	CHIP R 4.7K J 1/16W		R109			RK73HB1J331J	CHIP R 330 J 1/16W	
R13			RK73HB1J473J	CHIP R 47K J 1/16W		R110			RK73GB2A220J	CHIP R 22 J 1/10W	
R15-19			RK73HB1J100J	CHIP R 10 J 1/16W		R111			RK73HB1J561J	CHIP R 560 J 1/16W	
R21			RK73HB1J100J	CHIP R 10 J 1/16W		R112			RK73HB1J272J	CHIP R 2.7K J 1/16W	
R22,23			RK73HB1J102J	CHIP R 1.0K J 1/16W		R113			RK73GB2A100J	CHIP R 10 J 1/10W	
R25			RK73HB1J000J	CHIP R 0.0 J 1/16W		R114			RK73HB1J331J	CHIP R 330 J 1/16W	
R26			RK73HB1J104J	CHIP R 100K J 1/16W		R115			RK73HB1J000J	CHIP R 0.0 J 1/16W	
R27			RK73HB1J473J	CHIP R 47K J 1/16W		R117			RK73HB1J103J	CHIP R 10K J 1/16W	
R28			RK73HB1J683J	CHIP R 68K J 1/16W		R119			RK73HB1J473J	CHIP R 47K J 1/16W	
R29			RK73HB1J000J	CHIP R 0.0 J 1/16W		R120			RK73HB1J104J	CHIP R 100K J 1/16W	
R30			RK73HB1J184J	CHIP R 180K J 1/16W		R121			RK73GB2A000J	CHIP R 0.0 J 1/10W	
R31			RK73HB1J473J	CHIP R 47K J 1/16W		R122			RK73HB1J683J	CHIP R 68K J 1/16W	
R32			RK73HB1J151J	CHIP R 150 J 1/16W		R123			RK73HB1J273J	CHIP R 27K J 1/16W	
R34			RK73HB1J102J	CHIP R 1.0K J 1/16W		R124			RK73HB1J332J	CHIP R 3.3K J 1/16W	
R35			RK73HB1J391D	CHIP R 390 D 1/16W		R125			RK73FB2B271J	CHIP R 270 J 1/8W	
R36			RK73HB1J106J	CHIP R 10M J 1/16W		R126,127			RK73FB2B390J	CHIP R 39 J 1/8W	
R37			RK73HB1J103J	CHIP R 10K J 1/16W		R129			RK73FB2B271J	CHIP R 270 J 1/8W	
R40,41			RK73HB1J000J	CHIP R 0.0 J 1/16W		R131			RK73HB1J331J	CHIP R 330 J 1/16W	
R42			RK73HB1J104J	CHIP R 100K J 1/16W		R132,133			RK73HB1J104J	CHIP R 100K J 1/16W	
R43			RK73HB1J100J	CHIP R 10 J 1/16W		R134			RK73HB1J274J	CHIP R 270K J 1/16W	
R44			RK73HB1J000J	CHIP R 0.0 J 1/16W		R136			RK73HB1J104J	CHIP R 100K J 1/16W	
R45			RK73HB1J104J	CHIP R 100K J 1/16W		R137			RK73HB1J334J	CHIP R 330K J 1/16W	
						R138			RK73EB2E301J	CHIP R 300 J 1/4W	

PARTS LIST

TX-RX UNIT (X57-7750-18)

Ref. No.	Address	New parts	Parts No.	Description	Desti-nation	Ref. No.	Address	New parts	Parts No.	Description	Desti-nation
R140			RK73HB1J104J	CHIP R 100K J 1/16W		R265			RK73HB1J103J	CHIP R 10K J 1/16W	
R141			RK73HB1J124J	CHIP R 120K J 1/16W		R266			RK73HB1J222J	CHIP R 2.2K J 1/16W	
R142			RK73HB1J104J	CHIP R 100K J 1/16W		R267			RK73HB1J271J	CHIP R 270 J 1/16W	
R143			RK73GB2A000J	CHIP R 0.0 J 1/10W		R268,269			RK73HB1J470J	CHIP R 47 J 1/16W	
R144			RK73HB1J824J	CHIP R 820K J 1/16W		R270			RK73HB1J680J	CHIP R 68 J 1/16W	
R145			RK73HB1J393J	CHIP R 39K J 1/16W		R271			RK73HB1J222J	CHIP R 2.2K J 1/16W	
R146,147			RK73HB1J104J	CHIP R 100K J 1/16W		R272			RK73HB1J271J	CHIP R 270 J 1/16W	
R148			RK73HB1J103J	CHIP R 10K J 1/16W		R273			RK73HB1J180J	CHIP R 18 J 1/16W	
R149			RK73HB1J823J	CHIP R 82K J 1/16W		R274			RK73HB1J102J	CHIP R 1.0K J 1/16W	
R150			RK73HB1J683J	CHIP R 68K J 1/16W		R275			RK73HB1J271J	CHIP R 270 J 1/16W	
R151			RK73HB1J154J	CHIP R 150K J 1/16W		R276			RK73HB1J102J	CHIP R 1.0K J 1/16W	
R152			R92-1061-05	JUMPER REST 0.0		R277			RK73GB2A000J	CHIP R 0.0 J 1/10W	
R153			RK73HB1J151J	CHIP R 150 J 1/16W		R278			RK73HB1J271J	CHIP R 270 J 1/16W	
R154			RK73EB2E301J	CHIP R 300 J 1/4W		R279			RK73HB1J180J	CHIP R 18 J 1/16W	
R156			RK73HB1J000J	CHIP R 0.0 J 1/16W		R280			RK73HB1J271J	CHIP R 270 J 1/16W	
R158			RK73HB1J000J	CHIP R 0.0 J 1/16W		R282			RK73HB1J000J	CHIP R 0.0 J 1/16W	
R160			RK73HB1J000J	CHIP R 0.0 J 1/16W		R283,284			RK73HB1J104J	CHIP R 100K J 1/16W	
R161			RK73HB1J332J	CHIP R 3.3K J 1/16W		R285			RK73HB1J103J	CHIP R 10K J 1/16W	
R201			RK73HB1J222J	CHIP R 2.2K J 1/16W		R286,287			RK73HB1J104J	CHIP R 100K J 1/16W	
R202,203			RK73HB1J223J	CHIP R 22K J 1/16W		R288			RK73HB1J101J	CHIP R 100 J 1/16W	
R204			RK73HB1J470J	CHIP R 47 J 1/16W		R289			RK73HB1J104J	CHIP R 100K J 1/16W	
R205,206			RK73HB1J223J	CHIP R 22K J 1/16W		R290			RK73HB1J274J	CHIP R 270K J 1/16W	
R207			RK73HB1J334J	CHIP R 330K J 1/16W		R291			RK73HB1J104J	CHIP R 100K J 1/16W	
R208			RK73HB1J153J	CHIP R 15K J 1/16W		R294			RK73HB1J000J	CHIP R 0.0 J 1/16W	
R209,210			RK73HB1J100J	CHIP R 10 J 1/16W		R296			RK73HB1J103J	CHIP R 10K J 1/16W	
R211			RK73HB1J102J	CHIP R 1.0K J 1/16W		R297,298			RK73HB1J000J	CHIP R 0.0 J 1/16W	
R212			RK73HB1J000J	CHIP R 0.0 J 1/16W		R299			RK73HB1J221J	CHIP R 220 J 1/16W	
R213			RK73HB1J102J	CHIP R 1.0K J 1/16W		R300			RK73HB1J000J	CHIP R 0.0 J 1/16W	
R215			RK73HB1J332J	CHIP R 3.3K J 1/16W		R301			RK73HB1J564J	CHIP R 560K J 1/16W	
R216			RK73HB1J000J	CHIP R 0.0 J 1/16W		R302,303			RK73HB1J104J	CHIP R 100K J 1/16W	
R218,219			RK73HB1J103J	CHIP R 10K J 1/16W		R306,307			RK73HB1J183J	CHIP R 18K J 1/16W	
R220			RK73HB1J473J	CHIP R 47K J 1/16W		R310			RK73HB1J000J	CHIP R 0.0 J 1/16W	
R221			RK73HB1J183J	CHIP R 18K J 1/16W		R313			RK73GB2A000J	CHIP R 0.0 J 1/10W	
R222			RK73HB1J222J	CHIP R 2.2K J 1/16W		R314			RK73HB1J000J	CHIP R 0.0 J 1/16W	
R223			RK73HB1J274J	CHIP R 270K J 1/16W		R315,316			RK73HB1J104J	CHIP R 100K J 1/16W	
R224			RK73HB1J103J	CHIP R 10K J 1/16W		R317			RK73HB1J000J	CHIP R 0.0 J 1/16W	
R225			RK73HB1J153J	CHIP R 15K J 1/16W		R320,321			RK73HB1J000J	CHIP R 0.0 J 1/16W	
R226			RK73HB1J473J	CHIP R 47K J 1/16W		R326			RK73HB1J122J	CHIP R 1.2K J 1/16W	
R227			RK73HB1J104J	CHIP R 100K J 1/16W		R328			RK73HB1J102J	CHIP R 1.0K J 1/16W	
R228			RK73HB1J223J	CHIP R 22K J 1/16W		R329			RK73HB1J682J	CHIP R 6.8K J 1/16W	
R229			RK73HB1J222J	CHIP R 2.2K J 1/16W		R330			RK73GB2A100J	CHIP R 10 J 1/10W	
R230			RK73HB1J102J	CHIP R 1.0K J 1/16W		R331			RK73HB1J473J	CHIP R 47K J 1/16W	
R231			RK73HB1J221J	CHIP R 220 J 1/16W		R332			RK73HB1J000J	CHIP R 0.0 J 1/16W	
R232			RK73HB1J101J	CHIP R 100 J 1/16W		R333			RK73HB1J102J	CHIP R 1.0K J 1/16W	
R234			RK73HB1J103J	CHIP R 10K J 1/16W		R334			RK73HB1J000J	CHIP R 0.0 J 1/16W	
R235			RK73HB1J000J	CHIP R 0.0 J 1/16W		R338			RK73HB1J000J	CHIP R 0.0 J 1/16W	
R237			RK73HB1J104J	CHIP R 100K J 1/16W		R339			RK73HB1J470J	CHIP R 47 J 1/16W	
R238			RK73HB1J103J	CHIP R 10K J 1/16W		R340,341			RK73HB1J121J	CHIP R 120 J 1/16W	
R239			RK73HB1J104J	CHIP R 100K J 1/16W		R342-345			RK73HB1J000J	CHIP R 0.0 J 1/16W	
R242			RK73HB1J221J	CHIP R 220 J 1/16W		R346			RK73HB1J223J	CHIP R 22K J 1/16W	
R243			RK73HB1J101J	CHIP R 100 J 1/16W		R352-354			RK73HB1J000J	CHIP R 0.0 J 1/16W	
R244			RK73HB1J000J	CHIP R 0.0 J 1/16W		R401			RK73HH1J105D	CHIP R 1.0M D 1/16W	
R245,246			RK73HB1J104J	CHIP R 100K J 1/16W		R402			RK73HB1J471J	CHIP R 470 J 1/16W	
R248			RK73HB1J474J	CHIP R 470K J 1/16W		R403			RK73HH1J104D	CHIP R 100K D 1/16W	
R250			RK73HB1J000J	CHIP R 0.0 J 1/16W		R404			RK73HB1J103J	CHIP R 10K J 1/16W	
R256			RK73HB1J181J	CHIP R 180 J 1/16W		R405			RK73HH1J274D	CHIP R 270K D 1/16W	
R257			RK73HB1J000J	CHIP R 0.0 J 1/16W		R406			RK73HH1J104D	CHIP R 100K D 1/16W	
R261			RK73HB1J472J	CHIP R 4.7K J 1/16W		R407			RK73HB1J473J	CHIP R 47K J 1/16W	
R262			RK73HB1J682J	CHIP R 6.8K J 1/16W		R408			RK73HB1J103J	CHIP R 10K J 1/16W	
R263			RK73HB1J000J	CHIP R 0.0 J 1/16W		R409			RK73HB1J683J	CHIP R 68K J 1/16W	

PARTS LIST

TX-RX UNIT (X57-7750-18)

Ref. No.	Address	New parts	Parts No.	Description	Destination	Ref. No.	Address	New parts	Parts No.	Description	Destination
R410			RK73HB1J684J	CHIP R 680K J 1/16W		R545			RK73HB1J000J	CHIP R 0.0 J 1/16W	
R411			RK73HB1J104J	CHIP R 100K J 1/16W		R548			RK73GB2A000J	CHIP R 0.0 J 1/10W	
R413			RK73HB1J474J	CHIP R 470K J 1/16W		R550			RK73GB2A000J	CHIP R 0.0 J 1/10W	
R415			RK73HB1J332J	CHIP R 3.3K J 1/16W		R551			RK73HB1J101J	CHIP R 100 J 1/16W	
R417			RK73HB1J473J	CHIP R 47K J 1/16W		R552-554			RK73HB1J104J	CHIP R 100K J 1/16W	
R418,419			RK73HB1J103J	CHIP R 10K J 1/16W		R556-558			RK73HB1J104J	CHIP R 100K J 1/16W	
R420			RK73HB1J473J	CHIP R 47K J 1/16W		R560			RK73HB1J000J	CHIP R 0.0 J 1/16W	
R421			RK73HB1J474J	CHIP R 470K J 1/16W		R561			RK73HB1J473J	CHIP R 47K J 1/16W	
R422			RK73HB1J103J	CHIP R 10K J 1/16W		R562			RK73GB2A000J	CHIP R 0.0 J 1/10W	
R423-425			RK73GB2A472J	CHIP R 4.7K J 1/10W		R565			RK73GB2A000J	CHIP R 0.0 J 1/10W	
R426			RK73HB1J474J	CHIP R 470K J 1/16W		R567			RK73HB1J151J	CHIP R 150 J 1/16W	
R428,429			RK73HB1J103J	CHIP R 10K J 1/16W		R568			RK73HB1J102J	CHIP R 1.0K J 1/16W	
R430			RK73HH1J124D	CHIP R 120K D 1/16W		R569			RK73HB1J220J	CHIP R 22 J 1/16W	
R431			RK73HH1J183D	CHIP R 18K D 1/16W		R572			RK73HB1J220J	CHIP R 22 J 1/16W	
R432			RK73HH1J223D	CHIP R 22K D 1/16W		R574			RK73GB2A000J	CHIP R 0.0 J 1/10W	
R433			RK73HB1J102J	CHIP R 1.0K J 1/16W		R575			RK73HB1J103J	CHIP R 10K J 1/16W	
R434			RK73HB1J330J	CHIP R 33 J 1/16W		R576			RK73HB1J000J	CHIP R 0.0 J 1/16W	
R435			RK73GB2A100J	CHIP R 10 J 1/10W		R577			RK73HB1J102J	CHIP R 1.0K J 1/16W	
R436			RK73HB1J000J	CHIP R 0.0 J 1/16W		R578-580			RK73HB1J000J	CHIP R 0.0 J 1/16W	
R437			RK73HB1J474J	CHIP R 470K J 1/16W		R581			RK73HB1J474J	CHIP R 470K J 1/16W	
R438			RK73HB1J154J	CHIP R 150K J 1/16W		R582-586			RK73HB1J000J	CHIP R 0.0 J 1/16W	
R440			RK73HB1J102J	CHIP R 1.0K J 1/16W		R587			RK73HB1J102J	CHIP R 1.0K J 1/16W	
R441			RK73HB1J123J	CHIP R 12K J 1/16W		R588-590			RK73HB1J000J	CHIP R 0.0 J 1/16W	
R442			RK73HH1J334D	CHIP R 330K D 1/16W		R591			RK73HB1J102J	CHIP R 1.0K J 1/16W	
R443			RK73HH1J223D	CHIP R 22K D 1/16W		R592,593			RK73HB1J000J	CHIP R 0.0 J 1/16W	
R444			RK73HB1J272J	CHIP R 2.7K J 1/16W		R594			RK73HB1J102J	CHIP R 1.0K J 1/16W	
R445			RK73HB1J473J	CHIP R 47K J 1/16W		R595			RK73HB1J000J	CHIP R 0.0 J 1/16W	
R446			RK73GB2A100J	CHIP R 10 J 1/10W		R596			RK73HB1J104J	CHIP R 100K J 1/16W	
R447			RK73HB1J473J	CHIP R 47K J 1/16W		R597			RK73HB1J102J	CHIP R 1.0K J 1/16W	
R448			RK73HB1J000J	CHIP R 0.0 J 1/16W		R598-601			RK73FB2B102J	CHIP R 1.0K J 1/8W	
R449			RK73GB2A220J	CHIP R 22 J 1/10W		R602			RK73HB1J102J	CHIP R 1.0K J 1/16W	
R450			RK73HB1J000J	CHIP R 0.0 J 1/16W		R603,604			RK73HB1J000J	CHIP R 0.0 J 1/16W	
R501			RK73HB1J104J	CHIP R 100K J 1/16W		R605			RK73HB1J102J	CHIP R 1.0K J 1/16W	
R503			RK73HB1J102J	CHIP R 1.0K J 1/16W		R606			RK73HB1J103J	CHIP R 10K J 1/16W	
R504			RK73HB1J104J	CHIP R 100K J 1/16W		R607,608			RK73HB1J102J	CHIP R 1.0K J 1/16W	
R506			RK73HB1J474J	CHIP R 470K J 1/16W		R610			RK73HB1J102J	CHIP R 1.0K J 1/16W	
R507			RK73HB1J000J	CHIP R 0.0 J 1/16W		R611,612			RK73HB1J105J	CHIP R 1.0M J 1/16W	
R509			RK73HB1J000J	CHIP R 0.0 J 1/16W		R614			RK73HB1J474J	CHIP R 470K J 1/16W	
R510			RK73HB1J474J	CHIP R 470K J 1/16W		R615,616			RK73HB1J000J	CHIP R 0.0 J 1/16W	
R511			RK73HB1J220J	CHIP R 22 J 1/16W		R617-620			RK73HB1J102J	CHIP R 1.0K J 1/16W	
R512			RK73HB1J104J	CHIP R 100K J 1/16W		R621			RK73HB1J000J	CHIP R 0.0 J 1/16W	
R514			RK73HB1J000J	CHIP R 0.0 J 1/16W		R622			RK73HB1J102J	CHIP R 1.0K J 1/16W	
R515,516			RK73HB1J104J	CHIP R 100K J 1/16W		R623-625			RK73HB1J104J	CHIP R 100K J 1/16W	
R520,521			RK73HB1J473J	CHIP R 47K J 1/16W		R627,628			RK73HB1J104J	CHIP R 100K J 1/16W	
R522			RK73HB1J474J	CHIP R 470K J 1/16W		R629			RK73HB1J105J	CHIP R 1.0M J 1/16W	
R523			RK73HB1J473J	CHIP R 47K J 1/16W		R630			RK73HB1J102J	CHIP R 1.0K J 1/16W	
R524			RK73HB1J000J	CHIP R 0.0 J 1/16W		R632			RK73HB1J103J	CHIP R 10K J 1/16W	
R525			RK73HB1J104J	CHIP R 100K J 1/16W		R633			RK73HB1J000J	CHIP R 0.0 J 1/16W	
R527			RK73HB1J104J	CHIP R 100K J 1/16W		R634			RK73HB1J103J	CHIP R 10K J 1/16W	
R528,529			RK73HB1J000J	CHIP R 0.0 J 1/16W		R636			RK73HB1J000J	CHIP R 0.0 J 1/16W	
R531			RK73HB1J104J	CHIP R 100K J 1/16W		R637			RK73HB1J103J	CHIP R 10K J 1/16W	
R532			RK73HB1J101J	CHIP R 100 J 1/16W		R638			RK73HB1J104J	CHIP R 100K J 1/16W	
R533,534			RK73HB1J000J	CHIP R 0.0 J 1/16W		R639			RK73HB1J102J	CHIP R 1.0K J 1/16W	
R536,537			RK73HB1J000J	CHIP R 0.0 J 1/16W		R640			RK73HB1J103J	CHIP R 10K J 1/16W	
R538			RK73HB1J101J	CHIP R 100 J 1/16W		R641,642			RK73HB1J104J	CHIP R 100K J 1/16W	
R539			RK73HB1J000J	CHIP R 0.0 J 1/16W		R644			RK73GB2A000J	CHIP R 0.0 J 1/10W	
R540,541			RK73HB1J101J	CHIP R 100 J 1/16W		R646			RK73HB1J682J	CHIP R 6.8K J 1/16W	
R542			RK73HB1J104J	CHIP R 100K J 1/16W		R648			RK73HB1J682J	CHIP R 6.8K J 1/16W	
R543			RK73HB1J000J	CHIP R 0.0 J 1/16W		R650			RK73GB2A000J	CHIP R 0.0 J 1/10W	
R544			RK73HB1J104J	CHIP R 100K J 1/16W		R651			RK73FB2B102J	CHIP R 1.0K J 1/8W	

PARTS LIST

TX-RX UNIT (X57-7750-18)

Ref. No.	Address	New parts	Parts No.	Description	Destination	Ref. No.	Address	New parts	Parts No.	Description	Destination
R652			RK73HB1J104J	CHIP R 100K J 1/16W		R755			RK73HB1J103J	CHIP R 10K J 1/16W	
R654			RK73GB2A000J	CHIP R 0.0 J 1/10W		R756			RK73HB1J153J	CHIP R 15K J 1/16W	
R656			RK73HB1J471J	CHIP R 470 J 1/16W		R758			RK73HB1J103J	CHIP R 10K J 1/16W	
R658			RK73GB2A000J	CHIP R 0.0 J 1/10W		R759			RK73HB1J104J	CHIP R 100K J 1/16W	
R659-661			RK73HB1J104J	CHIP R 100K J 1/16W		R760			RK73HB1J152J	CHIP R 1.5K J 1/16W	
R662,663			RK73HB1J474J	CHIP R 470K J 1/16W		R761			RK73HB1J683J	CHIP R 68K J 1/16W	
R664-674			RK73HB1J104J	CHIP R 100K J 1/16W		R762			RK73HB1J334J	CHIP R 330K J 1/16W	
R676			RK73HB1J104J	CHIP R 100K J 1/16W		R763			RK73HB1J183J	CHIP R 18K J 1/16W	
R677			RK73HB1J474J	CHIP R 470K J 1/16W		R764			RK73HB1J124J	CHIP R 120K J 1/16W	
R678			RK73HB1J104J	CHIP R 100K J 1/16W		R765			RK73HB1J102J	CHIP R 1.0K J 1/16W	
R680-683			RK73HB1J102J	CHIP R 1.0K J 1/16W		R766			RK73HB1J104J	CHIP R 100K J 1/16W	
R684-686			RK73HB1J104J	CHIP R 100K J 1/16W		R767,768			RK73HB1J473J	CHIP R 47K J 1/16W	
R687,688			RK73HB1J472J	CHIP R 4.7K J 1/16W		R769			RK73HB1J472J	CHIP R 4.7K J 1/16W	
R689,690			RK73HB1J474J	CHIP R 470K J 1/16W		R770			RK73HB1J563J	CHIP R 56K J 1/16W	
R691-696			RK73HB1J104J	CHIP R 100K J 1/16W		R771			RK73HB1J104J	CHIP R 100K J 1/16W	
R697,698			RK73HB1J000J	CHIP R 0.0 J 1/16W		R772			RK73HB1J123J	CHIP R 12K J 1/16W	
R701			RK73HB1J104J	CHIP R 100K J 1/16W		R773			RK73HB1J684J	CHIP R 680K J 1/16W	
R703			RK73HB1J103J	CHIP R 10K J 1/16W		R774			RK73HB1J474J	CHIP R 470K J 1/16W	
R704			RK73HB1J563J	CHIP R 56K J 1/16W		R775			RK73HB1J823J	CHIP R 82K J 1/16W	
R705			RK73HB1J104J	CHIP R 100K J 1/16W		R776			RK73HB1J334J	CHIP R 330K J 1/16W	
R706			RK73HB1J683J	CHIP R 68K J 1/16W		R777			RK73HB1J154J	CHIP R 150K J 1/16W	
R707			RK73HB1J153J	CHIP R 15K J 1/16W		R778			RK73HB1J394J	CHIP R 390K J 1/16W	
R708			RK73HB1J683J	CHIP R 68K J 1/16W		R779			RK73HB1J474J	CHIP R 470K J 1/16W	
R709			RK73HB1J822J	CHIP R 8.2K J 1/16W		R782			RK73HB1J153J	CHIP R 15K J 1/16W	
R710			RK73HB1J104J	CHIP R 100K J 1/16W		R783			RK73HB1J000J	CHIP R 0.0 J 1/16W	
R712			RK73HB1J683J	CHIP R 68K J 1/16W		R784			RK73HB1J154J	CHIP R 150K J 1/16W	
R713			RK73HB1J563J	CHIP R 56K J 1/16W		R785			RK73HB1J103J	CHIP R 10K J 1/16W	
R714			RK73HB1J104J	CHIP R 100K J 1/16W		R786			RK73HB1J393J	CHIP R 39K J 1/16W	
R715			RK73HB1J274J	CHIP R 47K J 1/16W		R787			RK73HB1J274J	CHIP R 270K J 1/16W	
R716			RK73HB1J000J	CHIP R 0.0 J 1/16W		R788			RK73HB1J223J	CHIP R 22K J 1/16W	
R717			RK73HB1J393J	CHIP R 39K J 1/16W		R789			RK73HB1J000J	CHIP R 0.0 J 1/16W	
R718			RK73HB1J000J	CHIP R 0.0 J 1/16W		R790			RK73HB1J224J	CHIP R 220K J 1/16W	
R720			RK73HB1J104J	CHIP R 100K J 1/16W		R791			RK73HB1J564J	CHIP R 560K J 1/16W	
R721			RK73HB1J222J	CHIP R 2.2K J 1/16W		R792			RK73HB1J102J	CHIP R 1.0K J 1/16W	
R722			RK73HB1J683J	CHIP R 68K J 1/16W		R793,794			RK73HB1J000J	CHIP R 0.0 J 1/16W	
R724			RK73HB1J563J	CHIP R 56K J 1/16W		R795			RK73HB1J224J	CHIP R 220K J 1/16W	
R725			RK73HB1J683J	CHIP R 68K J 1/16W		R796			RK73HB1J103J	CHIP R 10K J 1/16W	
R726			RK73HB1J100J	CHIP R 10 J 1/16W		R797			RK73HB1J334J	CHIP R 330K J 1/16W	
R727			RK73HB1J274J	CHIP R 270K J 1/16W		R798			RK73HB1J684J	CHIP R 680K J 1/16W	
R728			RK73HB1J000J	CHIP R 0.0 J 1/16W		R799			RK73HB1J563J	CHIP R 56K J 1/16W	
R729			RK73HB1J104J	CHIP R 100K J 1/16W		R800			RK73HB1J472J	CHIP R 4.7K J 1/16W	
R730			RK73HB1J103J	CHIP R 10K J 1/16W		R801			RK73HB1J104J	CHIP R 100K J 1/16W	
R731			RK73HB1J000J	CHIP R 0.0 J 1/16W		R802			RK73HB1J273J	CHIP R 27K J 1/16W	
R732			RK73HB1J473J	CHIP R 47K J 1/16W		R803			RK73HB1J153J	CHIP R 15K J 1/16W	
R733			RK73HB1J333J	CHIP R 33K J 1/16W		R804			RK73HB1J681J	CHIP R 680 J 1/16W	
R734			RK73HB1J223J	CHIP R 22K J 1/16W		R805			RK73HB1J823J	CHIP R 82K J 1/16W	
R737			RK73HB1J473J	CHIP R 47K J 1/16W		R806			RK73HB1J562J	CHIP R 5.6K J 1/16W	
R738			RK73HB1J102J	CHIP R 1.0K J 1/16W		R807,808			RK73HB1J103J	CHIP R 10K J 1/16W	
R739			RK73HB1J000J	CHIP R 0.0 J 1/16W		R809			RK73HB1J104J	CHIP R 100K J 1/16W	
R740,741			RK73HB1J104J	CHIP R 100K J 1/16W		R810			RK73HB1J102J	CHIP R 1.0K J 1/16W	
R744			RK73HB1J473J	CHIP R 47K J 1/16W		R812,813			RK73HB1J472J	CHIP R 4.7K J 1/16W	
R745			RK73HB1J104J	CHIP R 100K J 1/16W		R814-816			RK73HB1J104J	CHIP R 100K J 1/16W	
R746			RK73HB1J103J	CHIP R 10K J 1/16W		R817			RK73HB1J473J	CHIP R 47K J 1/16W	
R747			RK73HB1J334J	CHIP R 330K J 1/16W		R818			RK73HB1J333J	CHIP R 33K J 1/16W	
R748			RK73HB1J000J	CHIP R 0.0 J 1/16W		R819			RK73HB1J000J	CHIP R 0.0 J 1/16W	
R749			RK73HB1J823J	CHIP R 82K J 1/16W		R820			RK73HB1J474J	CHIP R 470K J 1/16W	
R750			RK73HB1J332J	CHIP R 3.3K J 1/16W		R821			RK73HB1J000J	CHIP R 0.0 J 1/16W	
R751			RK73HB1J271J	CHIP R 270 J 1/16W		R822			RK73HB1J101J	CHIP R 100 J 1/16W	
R752			RK73HB1J102J	CHIP R 1.0K J 1/16W		R823			RK73HB1J472J	CHIP R 4.7K J 1/16W	
R753			RK73HB1J563J	CHIP R 56K J 1/16W		R825,826			RK73HB1J103J	CHIP R 10K J 1/16W	

PARTS LIST

TX-RX UNIT (X57-7750-18)

Ref. No.	Address	New parts	Parts No.	Description	Destination	Ref. No.	Address	New parts	Parts No.	Description	Destination
R827			RK73HB1J332J	CHIP R 3.3K J 1/16W		D909			1SS355	DIODE	
R828			RK73HB1J000J	CHIP R 0.0 J 1/16W		D910			02DZ18F-X	ZENER DIODE	
R831			RK73HB1J000J	CHIP R 0.0 J 1/16W		D911,912			DA204U	DIODE	
R833-835			RK73HB1J101J	CHIP R 100 J 1/16W		D913			1SS355	DIODE	
R836			RK73HB1J000J	CHIP R 0.0 J 1/16W		D914			02DZ18F-X	ZENER DIODE	
R837			RK73HB1J472J	CHIP R 4.7K J 1/16W		IC1			LM73CIMKX-0	MOS-IC	
R838			RK73HB1J000J	CHIP R 0.0 J 1/16W		IC2			LMC7101BIM5	MOS-IC	
R841			RK73HB1J000J	CHIP R 0.0 J 1/16W		IC3			Note 1	MOS-IC	
R842			RK73FB2102J	CHIP R 1.0K J 1/8W		IC4			LMC7101BIM5	MOS-IC	
R843			RK73HB1J471J	CHIP R 470 J 1/16W		IC5			TC75W51FK(F)	MOS-IC	
R845			RK73HB1J102J	CHIP R 1.0K J 1/16W		IC101			TA75W01FUJ	MOS-IC	
R846			RK73HB1J332J	CHIP R 3.3K J 1/16W		IC102	2A	*	RA55H3340M131	MOS-IC	
R847			RK73HB1J000J	CHIP R 0.0 J 1/16W		IC103			TA75W01FUJ	MOS-IC	
R850			RK73GB2A000J	CHIP R 0.0 J 1/10W		IC201			MCP6021-E/OT	MOS-IC	
R901			RK73GB2A471J	CHIP R 470 J 1/10W		IC202			TK10931VTL-G	ANALOGUE IC	
R902,903			RK73HB1J101J	CHIP R 100 J 1/16W		IC203			TC75W51FK(F)	MOS-IC	
R904-913			RK73HB1J471J	CHIP R 470 J 1/16W		IC204			SPM5001	MOS-IC	
R914			RK73GB2A471J	CHIP R 470 J 1/10W		IC205,206			LMC7101BIM5	MOS-IC	
R915-917			RK73HB1J000J	CHIP R 0.0 J 1/16W		IC401			XC6108C23CMN	MOS-IC	
R918,919			RK73HB1J101J	CHIP R 100 J 1/16W		IC402			XC6204B332P1	ANALOGUE IC	
R920			RK73HB1J000J	CHIP R 0.0 J 1/16W		IC403	2A		NJM78M08FA-ZB	ANALOGUE IC	
R921			RK73HB1J474J	CHIP R 470K J 1/16W		IC404			TA7805FQ	MOS-IC	
R922			RK73HB1J000J	CHIP R 0.0 J 1/16W		IC405			LT1616ES6-PBF	ANALOGUE IC	
R923			RK73HB1J473J	CHIP R 47K J 1/16W		IC406			TK71733S	BI-POLAR IC	
D2			DA221	DIODE		IC407,408			XC6204B332M	MOS-IC	
D3,4			1SV325F	VARIABLE CAPACITANCE DIODE		IC409			XC6205B152PRN	ANALOGUE IC	
D7-12			1SV282-F	VARIABLE CAPACITANCE DIODE		IC410			XC9101D09AKR	ANALOGUE IC	
D14			1SV278F	VARIABLE CAPACITANCE DIODE		IC501			Note 1 (BGA)	ROM IC	
D21			HVC131	DIODE		IC502			Note 1 (BGA)	MCU	
D101			HVC131	DIODE		IC503			Note 1 (BGA)	SRAM IC	
D102			02DZ5.6F-X,Y	ZENER DIODE		IC504			RV5C386A	MOS-IC	
D103,104			L407CDB	DIODE (50V/1W)		IC505			TC7SH08FU-F	MOS-IC	
D106			L7091CER	DIODE		IC506			XC6109C29ANN	ANALOGUE IC	
D108-110			HSM88AS-E	DIODE		IC507			TC7SH126FU-F	MOS-IC	
D201,202			DAN235E	DIODE		IC508			SM5023CNDH-G	MOS-IC	
D205			HVC131	DIODE		IC509			TC7WT125FUJ	MOS-IC	
D207-210			1SV286F	VARIABLE CAPACITANCE DIODE		IC510			Note 1 (BGA)	MOS-IC	
D212,213			1SV286F	VARIABLE CAPACITANCE DIODE		IC511			TC7SH08FU-F	MOS-IC	
D216			HVC131	DIODE		IC512,513			TC7SET08FU-F	MOS-IC	
D401			02DZ18F-X	ZENER DIODE		IC514			TC7WBD125AFK	MOS-IC	
D403			1SS416	DIODE		IC515			TC7WT126FU-F	MOS-IC	
D404			22ZR-10D	SURGE ABSORBER		IC516			TC7WH126FU-F	MOS-IC	
D405			DSA3A1	DIODE		IC517			Note 1 (BGA)	MOS-IC	
D406			HSC119	DIODE		IC518			ADM202EARNZ	MOS-IC	
D407			CRS02-Q	DIODE		IC701			TC75S51FE(F)	MOS-IC	
D408			1SS301F	DIODE		IC702,703			TC75W51FK(F)	MOS-IC	
D409-412			1SS388F	DIODE		IC704			MCP6021-E/OT	MOS-IC	
D501,502			1SS388F	DIODE		IC705,706			TC75W51FK(F)	MOS-IC	
D503,504			1SS416	DIODE		IC707,708			TC7W53FK(F)	MOS-IC	
D506,507			1SS416	DIODE		IC709			TC75W51FK(F)	MOS-IC	
D508			DA204U	DIODE		IC710			TC7W53FK(F)	MOS-IC	
D509,510			1SS416	DIODE		IC711			TC75W51FK(F)	MOS-IC	
D511,512			DA204U	DIODE		IC712			M62364FP-F	MOS-IC	
D702			HSC119	DIODE		IC713			TC7W53FK(F)	MOS-IC	
D703-705			RB706F-40	DIODE		IC714			TC75S51FE(F)	MOS-IC	
D706,707			EMZ6.8N	ZENER DIODE		IC715	2A		LA4425A	MOS-IC	
D901-904			DA204U	DIODE		Q1			2SC5383-T111	TRANSISTOR	
D905,906			02DZ18F-X	ZENER DIODE		Q3			2SC5636	TRANSISTOR	
D907,908			DA204U	DIODE		Q4			2SC5383-T111	TRANSISTOR	
						Q5,6			2SK508NV(K52)	FET	

PARTS LIST

TX-RX UNIT (X57-7750-18)

Ref. No.	Address	New parts	Parts No.	Description	Destination	Ref. No.	Address	New parts	Parts No.	Description	Destination
Q7			SSM6L05FU-F	FET							
Q8			SSM3J05FU-F	FET							
Q9,10			2SC5636	TRANSISTOR							
Q11			2SK1215-E(E)	FET							
Q101			2SC5108(Y)F	TRANSISTOR							
Q102			2SC5455-A	TRANSISTOR							
Q105			RT1N141U-T111	TRANSISTOR							
Q106			2SK1830F	FET							
Q201			RT1P141U-T111	TRANSISTOR							
Q202			RT1N441U-T111	TRANSISTOR							
Q203			2SC5636	TRANSISTOR							
Q204,205			2SC3356(R23)	TRANSISTOR							
Q208			2SC5636	TRANSISTOR							
Q210			2SC3357-A	TRANSISTOR							
Q212			EMD9	TRANSISTOR							
Q401,402			RT1N141U-T111	TRANSISTOR							
Q403			RT1N140U-T111	TRANSISTOR							
Q404			2SJ645	FET							
Q405			2SA1955A-F	TRANSISTOR							
Q406			UPA672T-A	FET							
Q407-409			12A02CH	TRANSISTOR							
Q410			SSM3K15TE(F)	FET							
Q411,412			2SA1955A-F	TRANSISTOR							
Q413-415			RT1N141U-T111	TRANSISTOR							
Q416			SSM6L05FU-F	FET							
Q417			SSM5H01TU-F	FET							
Q501			UPA672T-A	FET							
Q701			SSM3K15TE(F)	FET							
Q702			2SC4617(Q)	TRANSISTOR							
Q703			SSM3K15TE(F)	FET							
Q704			2SC4738(GR)F	TRANSISTOR							
Q705			2SA1832(GR)F	TRANSISTOR							
Q706,707			2SJ243-A	FET							
Q708			2SA1832(GR)F	TRANSISTOR							
Q709			RT1N141U-T111	TRANSISTOR							
Q710			DTC363EU	DIGITAL TRANSISTOR							
Q901,902			QSX6	TRANSISTOR							
TH101,102			ERTJ0EV104H	THERMISTOR							
TH701			ERTJ0EV104H	THERMISTOR							
61	2A		W09-0971-05	LITHIUM CELL							

NX-800H

EXPLODED VIEW

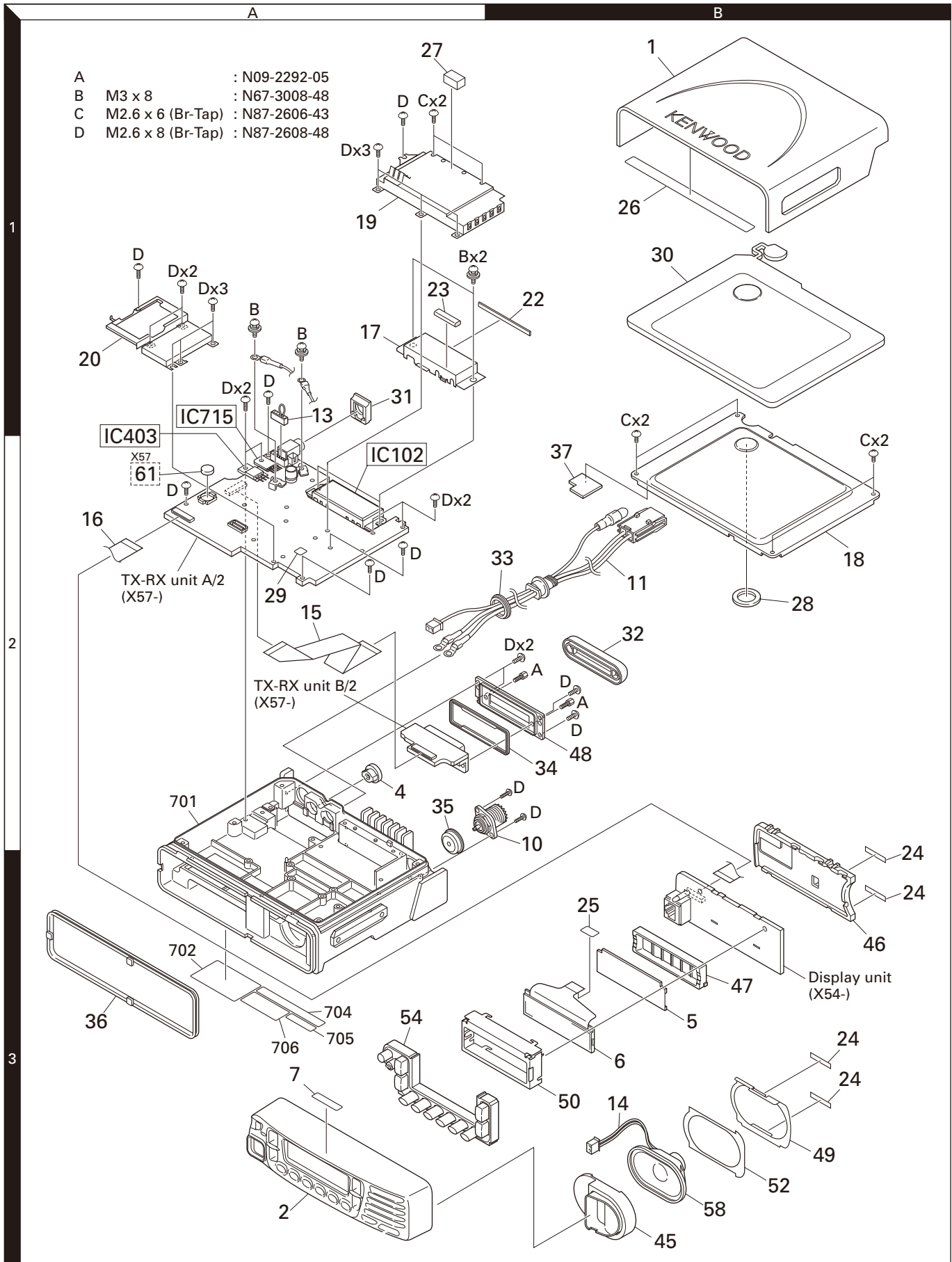

20 Parts with the exploded numbers larger than 700 are not supplied.
 If a part reference number is listed in a box on the exploded view of the PCB (for example, IC123), that part does not come with the PCB. These parts must be ordered separately.

ADJUSTMENT

■ Frequency and Signaling

The transceiver has been adjusted for the frequencies shown in the following table. When required, readjust them following the adjustment procedure to obtain the frequencies you want in actual operation.

• Test frequency

CH	RX (MHz)	TX (MHz)
1	390.05000	390.10000
2	380.05000	380.10000
3	399.95000	399.90000
4	390.00000	390.00000
5	390.20000	390.20000
6	390.40000	390.40000
7	335.05000	335.10000
8	365.05000	365.10000
9~16	-	-

• Analog mode signaling

No.	RX	TX
1	None	None
2	None	100Hz Square Wave
3	LTR Data : AREA=0, GOTO=12 HOME=12 ID=47, FREE=25	LTR Data : AREA=0, GOTO=12 HOME=12 ID=47, FREE=25
4	QT: 67.0Hz	QT: 67.0Hz
5	QT: 151.4Hz	QT: 151.4Hz
6	QT: 210.7Hz	QT: 210.7Hz
7	QT: 254.1Hz	QT: 254.1Hz
8	DQT: D023N	DQT: D023N
9	DQT: D754I	DQT: D754I
10	DTMF: 159D	DTMF: 159D
11	None	DTMF Code 9
12	2-tone : A: 304.7Hz B: 3106.0Hz	2-tone : A: 304.7Hz B: 3106.0Hz
13	Single Tone: 979.9Hz	Single Tone: 979.9Hz
14	None	Single Tone: 1000Hz
15	None	MSK
16	MSK	MSK

• NXDN mode signaling

No.	RX	TX
1	RAN1	RAN1
2	None	PN9
3	RAN1	Maximum deviation pattern
7	None	FSW+PN9 (PC test mode only)

RAN: Radio Access Number

PN9: Pseudo-Random Pattern (For production only)

Panel Tuning Mode

■ Preparations for tuning the transceiver

Before attempting to tune the transceiver, connect the unit to a suitable power supply.

Whenever the transmitter is turned, the unit must be connected to a suitable dummy load (i.e. power meter).

The speaker output connector must be terminated with a 4Ω dummy load and connected to an AC voltmeter and an audio distortion meter or a SINAD measurement meter at all times during tuning.

■ Transceiver tuning (To enter tuning mode)

To enter tuning mode, press the [T] key while the transceiver is in test mode. Use the [<] key to write tuning data through tuning modes, and the [▲]/[▼] key to adjust tuning requirements (1 to 4096 appears on the LCD).

Use the [▲>] key to select the adjustment item through tuning modes. Use the [5] key to adjust 5 reference level adjustments, and use the [■] key to switch between Wide/Narrow/Very narrow.

• LCD display in panel tuning mode

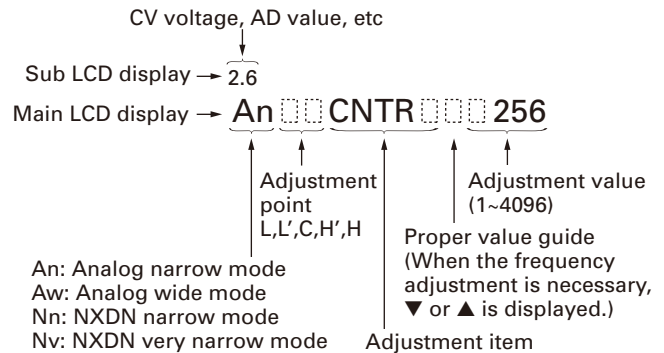

■ Key operation

Key	Function	
	Push	Hold (1 second)
[▲] / [▼]	Adjustment value up/down	Continuation up/down
[^] / [v]	Volume up/down	Continuation up/down
[▲]	Auto adjustment start	-
[■]	Wide/Narrow/Very narrow	-
[T]	Shift to panel test mode	-
[5]	To enter 5 reference level adjustments L/L',C/H',H	-
[<]	Writes the adjustment value	-
[▲>]	Go to next adjustment item	Back to last adjustment item
Microphone key		
[PTT]	Transmit	-
[0] to [9] and [A] to [D], [#], [*]	-	-

ADJUSTMENT

■ 5 reference level adjustments frequency

Tuning point	RX (MHz)	TX (MHz)
Low	335.05000	335.10000
Low'	347.55000	347.60000
Center	365.05000	365.10000
High'	382.55000	382.60000
High	399.95000	399.90000

Note:

Although the frequency range of this transceiver is 380 to 400MHz, the circuit and adjustments are designed under consideration of other market types.

When making adjustments, adjust at all frequency points following the service manual.

■ Adjustment item supplement

Adjustment Item	Description
LCD contrast	The contrast of LCD display can be changed.
Receive Assist	The lock voltage of VCO (Receive) is adjusted. This item must be adjusted before all adjustment items for receiver section are adjusted.
Transmit Assist	The lock voltage of VCO (Transmit) is adjusted. This item must be adjusted before all adjustment items for transmitter section are adjusted.
RTC	Real Time Clock (RTC) is adjusted. This item uses the internal clock. (Any measurement equipment is not required.)
Frequency	Frequency stability is adjusted under receiving condition with SSG. The SSG needs 0.001ppm accuracy so please use a standard oscillator if necessary. This item can be adjusted only in PC Test Mode so that the adjustment value is not changed easily.
High Transmit Power Limit	The limit value of the High Transmit Power output is adjusted.
Low Transmit Power Limit	The limit value of the Low Transmit Power output is adjusted.
High Transmit Power	High Transmit Power is adjusted.
Low Transmit Power	Low Transmit Power is adjusted.
Balance	The transmit audio frequency response is adjusted. This item is adjusted so that the deviation of 2kHz becomes the same deviation of 20Hz. This item must be adjusted before all adjustment items for deviations are adjusted.
Maximum Deviation (NXDN Narrow/Very Narrow)	Maximum Deviation of NXDN (Narrow/Very Narrow) is adjusted.
Maximum Deviation (Analog Wide/Narrow)	Maximum Deviation of Analog (Wide/Narrow) is adjusted. This item must be adjusted before all adjustment items for tone deviations are adjusted. Note: "Maximum Deviation (Analog Narrow)" must be adjusted before "CWID Deviation (NXDN Very Narrow)" is adjusted.
QT Deviation	QT tone deviation is adjusted.
DQT Deviation	DQT tone deviation is adjusted.
LTR Deviation	LTR tone deviation is adjusted.
DTMF Deviation	DTMF tone deviation is adjusted.
Single Tone Deviation	The deviation of Single Tone used in "2-tone" is adjusted.
MSK Deviation	MSK tone deviation is adjusted.
CWID Deviation	CWID tone deviation is adjusted. CWID is used to inform the others who is transmitting on a 6.25-kHz spacing channel. (In FCC rule, Analog mode or CWID is required for each channel-spacing.)
Sensitivity 1	Sensitivity 1 allows a service engineer to improve the intermodulation rejection, receiver spurious response, and receiver sensitivity characteristics by changing the voltage of Variable-Capacitor Tune in the receiver front-end circuit of the primary band-pass filter to optimize the characteristics at five frequency spots.
Sensitivity 2	Sensitivity 2 allows a service engineer to improve the intermodulation rejection, receiver spurious response, and receiver sensitivity characteristics by changing the voltage of Variable-Capacitor Tune in the receiver front-end circuit of the secondary band-pass filter to optimize the characteristics at five frequency spots.
RSSI Reference	The minimum RSSI level for scan stop is adjusted.
Open Squelch	The squelch level at level "5" is adjusted.

ADJUSTMENT

Adjustment Item	Description
Low RSSI	RSSI display level “  <h3>■ Adjustment item and Display</h3>

Order	Adjustment item	Main LCD display	Sub-LCD display	Aw (Analog Wide)	An (Analog Narrow)	Nn (NXDN Narrow)	Nv (NXDN Very Narrow)	Adjust item Number
				Adjustment range				
1	LCD contrast	CNTR	-	1 point ADJ				Common Section 2
				1~256				
2	Receive Assist	RAST	(CV voltage)	5 point ADJ				Common Section 3
				1~4096				
3	Transmit Assist	TAST	(CV voltage)	5 point ADJ				Common Section 3
				1~4096				
4	RTC (Real-time clock)	RTC	-	1 point ADJ				Common Section 4
				-62~-1/0/+1~+62				
5	High Transmit Power Limit	HILMT	-	-	5	-	-	Transmitter Section 1
				1~256				
6	Low Transmit Power Limit	LOLMT	-	-	5	-	-	Transmitter Section 2
				1~256				
7	High Transmit Power	HIPWR	-	-	5	-	-	Transmitter Section 3
				1~1024				
8	Low Transmit Power	LOPWR	-	-	5	-	-	Transmitter Section 4
				1~1024				
9	Balance	BAL	(Encode frequency)	-	5	-	-	Transmitter Section 5
				1~256				
10	Maximum Deviation (NXDN)	NDEV	-	-	-	5	5	Transmitter Section 6
				1~1024				
11	Maximum Deviation (Analog)	ADEV	-	5	5	-	-	Transmitter Section 7
				1~1024				
12	QT Deviation	QT	-	1	1	-	-	Transmitter Section 8
				1~1024				
13	DQT Deviation	DQT	-	1	1	-	-	Transmitter Section 9
				1~1024				
14	LTR Deviation	LTR	-	1	1	-	-	Transmitter Section 10
				1~1024				
15	DTMF Deviation	DTMF	-	1	1	-	-	Transmitter Section 11
				1~1024				
16	Single Tone Deviation	TONE	-	1	1	-	-	Transmitter Section 12
				1~1024				
17	MSK Deviation	MSK	-	1	1	-	-	Transmitter Section 13
				1~1024				
18	CWID Deviation	CWID	-	-	-	-	1	Transmitter Section 14
				1~1024				

ADJUSTMENT

Order	Adjustment item	Main LCD display	Sub-LCD display	Aw (Analog Wide)	An (Analog Narrow)	Nn (NXDN Narrow)	Nv (NXDN Very Narrow)	Adjust item Number
				Adjustment range				
19	Sensitivity 1	SENS1	(RSSI measurement value)	-	5	-	-	Receive Section 2
				1~256				
20	Sensitivity 2	SENS2	(RSSI measurement value)	-	5	-	-	Receive Section 3
				1~256				
21	RSSI Reference	RRSSI	(RSSI measurement value)	5	5	- *1	5	Receive Section 4
				1~256				
22	Open Squelch	SQL	(ASQDET measurement value)	5	5	- *1	5	Receive Section 5
				1~256				
23	Low RSSI	LRSSI	(RSSI measurement value)	5	5	- *1	5	Receive Section 6
				1~256				
24	High RSSI	HRSSI	(RSSI measurement value)	5	5	- *1	5	Receive Section 7
				1~256				
25	Tight Squelch	SQLT	(ASQDET measurement value)	5	5	-	-	Receive Section 8
				1~256				

*1: Because NXDN Narrow adjusted by adjusting Analog Narrow, it is not necessary to adjust NXDN Narrow.

■ Panel tuning mode flow chart

Note: In this Panel tuning mode flow chart, the Adjustment item name is modified.

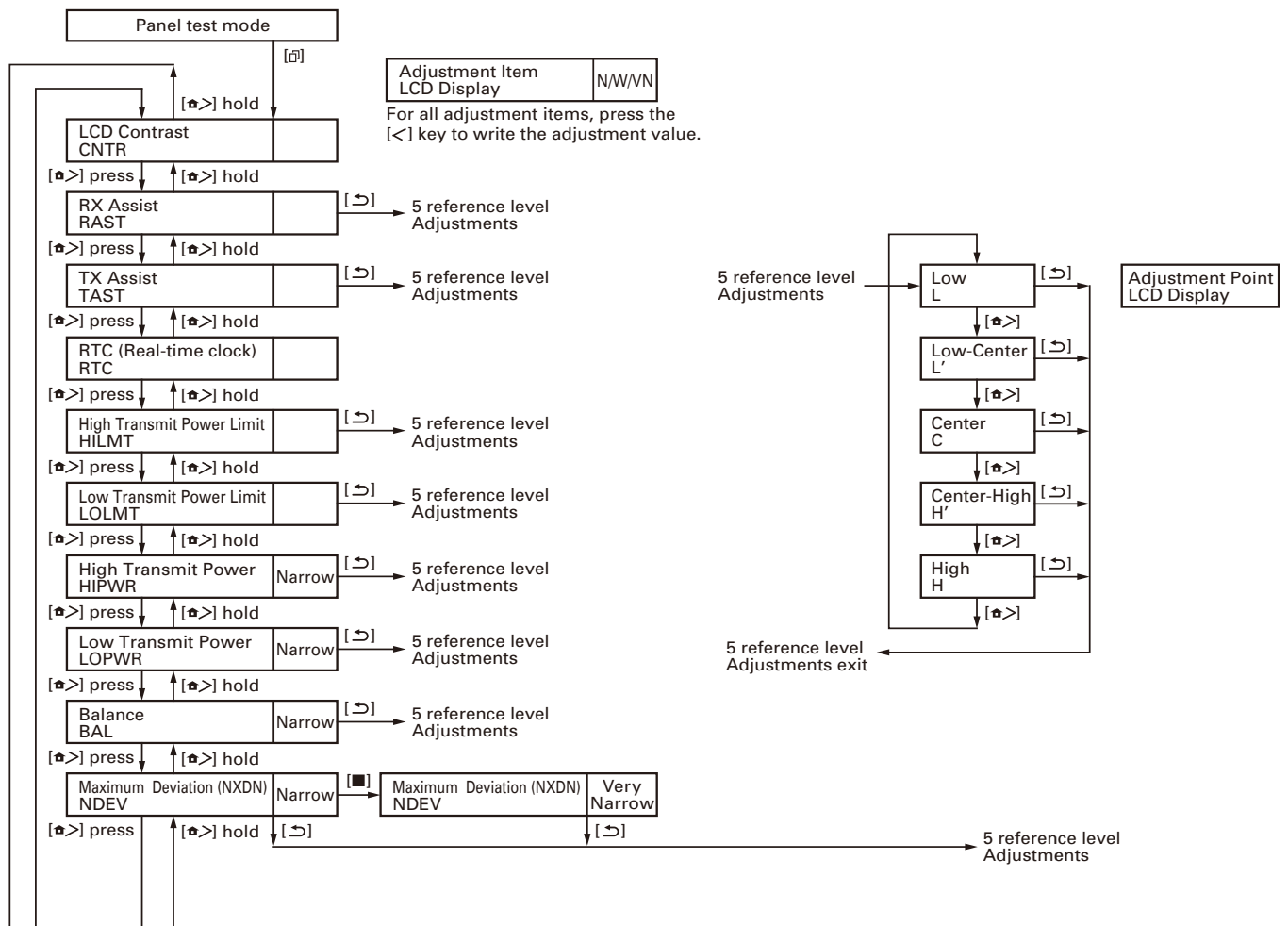

ADJUSTMENT

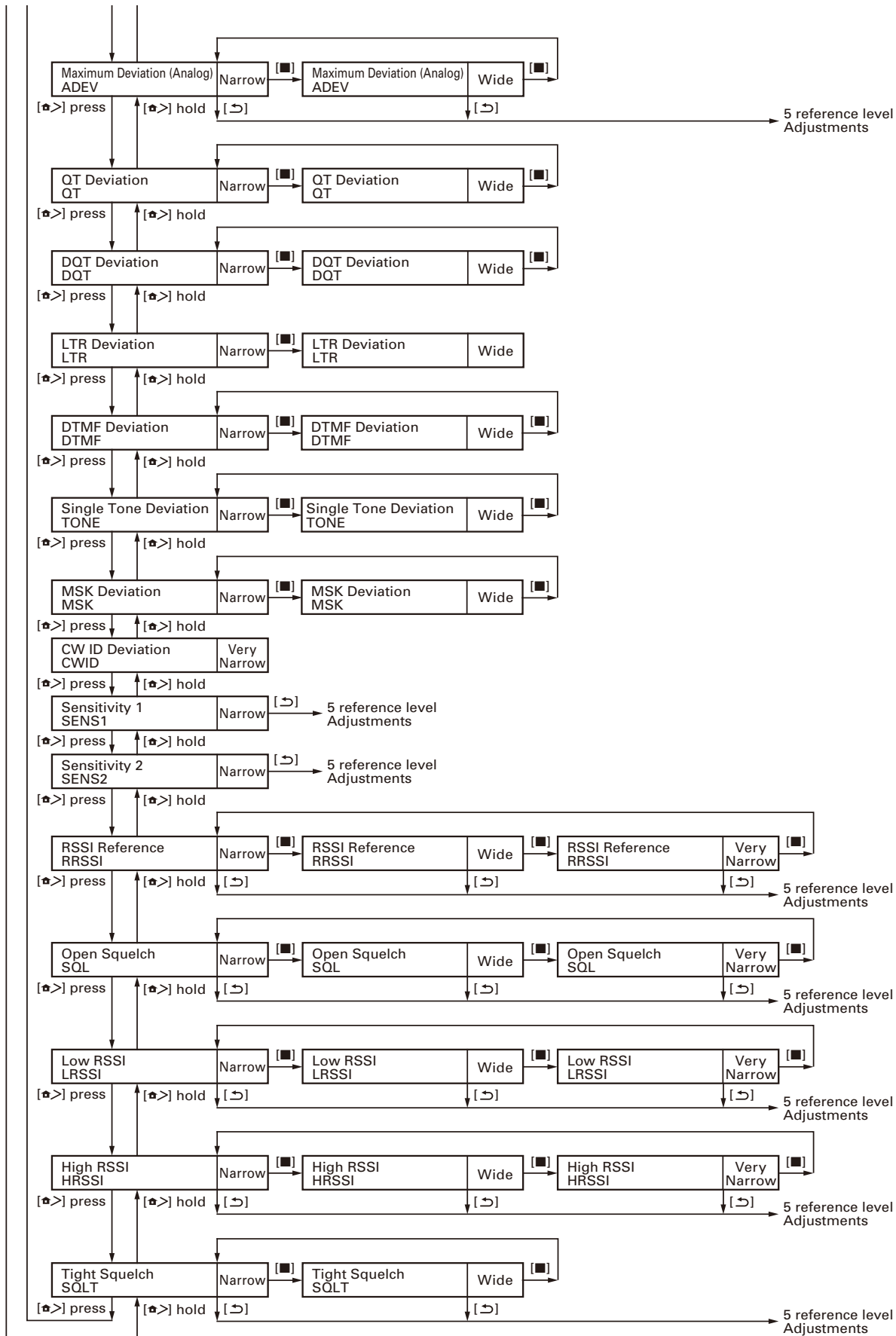

ADJUSTMENT

Test Equipment Required for Alignment

Test Equipment	Major Specifications
1. Standard Signal Generator (SSG)	Frequency Range 300 to 520MHz Modulation Frequency modulation and external modulation Output $-127\text{dBm}/0.1\mu\text{V}$ to greater than $-20\text{dBm}/22.4\text{mV}$ When performing the Frequency adjustment, the following accuracy is necessary. • 0.001ppm Use a standard oscillator for adjustments, if necessary.
2. RF Power Meter	Input Impedance 50Ω Operation Frequency 300 to 520MHz Measurement Capability Vicinity of 100W
3. Deviation Meter	Frequency Range 300 to 520MHz
4. Digital Volt Meter (DVM)	Measuring Range 10mV to 20V DC Input Impedance High input impedance for minimum circuit loading
5. Oscilloscope	DC through 30MHz
6. High Sensitivity Frequency Counter	Frequency Range 10Hz to 1000MHz Frequency Stability 0.01ppm or less
7. DC Ammeter	20A or more
8. AF Volt Meter (AF VTVM)	Frequency Range 50Hz to 10kHz Voltage Range 1mV to 10V
9. Audio Generator (AG)	Frequency Range 50Hz to 5kHz or more Output 0 to 1V
10. Distortion Meter	Capability 3% or less at 1kHz Input Level 50mV to 10Vrms
11. 4Ω Dummy Load	Approx. 4Ω, 20W
12. Regulated Power Supply	13.6V, approx. 20A (adjustable from 9V to 20V) Useful if ammeter equipped
13. Spectrum Analyzer	Frequency Range 40MHz to 520MHz Input Level Up to +20dBm Input Sensitivity -100dBm Resolution Bandwidth 100Hz Video Bandwidth 100Hz
14. Tracking Generator	Frequency Range 40MHz to 520MHz Output Level -30dBm to 0dBm

Test cable for microphone input (E30-3360-28)

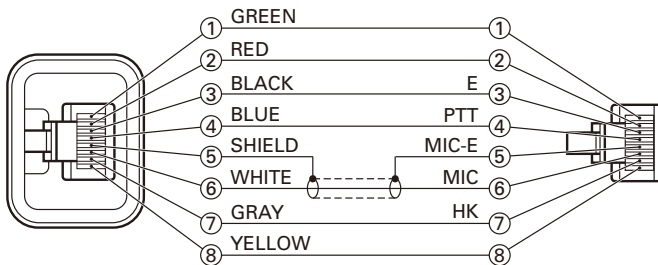

Tuning cable (E30-3383-05)

Adapter cable (E30-3383-05) is required for injecting an audio if PC tuning is used.

See "PC Mode" section for the connection.

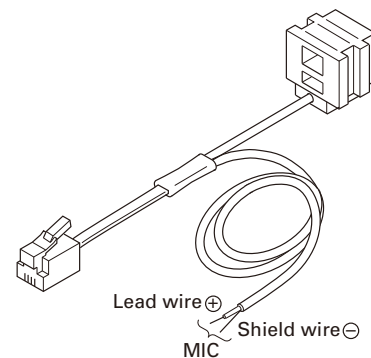

MIC connector (Front panel view)

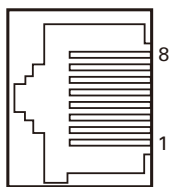

- 1 : BLC/AFO
- 2 : +B
- 3 : GND
- 4 : PTT/TXD (PC serial data from radio)
- 5 : MICE
- 6 : MIC
- 7 : HOOK/RXD (PC serial data to radio)
- 8 : DM/KVL

ADJUSTMENT

Radio Check Section

Item	Condition		Measurement			Adjustment			Specifications / Remarks
	Panel test mode	PC test mode	Test-equipment	Unit	Terminal	Unit	Parts	Method	
1. Frequency check	1) CH-Sig: 1-1 PTT: ON	1) Test Channel Channel: 1 Test Signaling Mode: Analog Signaling: 1 PTT: Press [Transmit] button.	f. counter	Panel	ANT			Check an internal temperature of radio within 25°C ± 2°C.	+0.05/+0.55ppm +19.51Hz~ +214.56Hz @390.1MHz
2. High power check	1) CH-Sig: 1-1 PTT: ON	1) Test Channel Channel: 1 Test Signaling Mode: Analog Signaling: 1 PTT: Press [Transmit] button.	Power meter Ammeter					Check	40W~50W 13A or less
	2) CH-Sig: 2-1 PTT: ON	2) Test Channel Channel: 2 Test Signaling Mode: Analog Signaling: 1 PTT: Press [Transmit] button.							
	3) CH-Sig: 3-1 PTT: ON	3) Test Channel Channel: 3 Test Signaling Mode: Analog Signaling: 1 PTT: Press [Transmit] button.							
3. Low power check	1) CH-Sig: 1-1 PTT: ON	1) Test Channel Channel: 1 Test Signaling Mode: Analog Signaling: 1 PTT: Press [Transmit] button.							7W~13W 8A or less
	2) CH-Sig: 2-1 PTT: ON	2) Test Channel Channel: 2 Test Signaling Mode: Analog Signaling: 1 PTT: Press [Transmit] button.							
	3) CH-Sig: 3-1 PTT: ON	3) Test Channel Channel: 3 Test Signaling Mode: Analog Signaling: 1 PTT: Press [Transmit] button.							
4. MIC sensitivity check	1) CH-Sig: 1-1 AG: 1kHz PTT: ON	1) Test Channel Channel: 1 Test Signaling Mode: Analog Signaling: 1 AG: 1kHz PTT: Press [Transmit] button.	Deviation meter Oscilloscope AG AF VTVM					Adjust AG input to get a standard MOD.	Dev: 3kHz at 5mV±1mV

ADJUSTMENT

Item	Condition		Measurement			Adjustment			Specifications / Remarks
	Panel test mode	PC test mode	Test-equipment	Unit	Terminal	Unit	Parts	Method	
5. Sensitivity check	1) CH-Sig : 1-1 SSG output Wide: -117dBm (0.32μV) (MOD: 1kHz/±3kHz) Narrow: -117dBm (0.32μV) (MOD: 1kHz, Dev: ±1.5kHz)	1) Test Channel Channel: 1 Test Signaling Mode: Analog Signaling: 1 SSG output Wide: -117dBm (0.32μV) (MOD: 1kHz/±3kHz) Narrow: -117dBm (0.32μV) (MOD: 1kHz, Dev : ±1.5kHz)	SSG AF VTVM Oscilloscope Distortion meter		ANT EXT SP connec- tor			Check	12dB SINAD or more

Common Section

Item	Condition		Measurement			Adjustment			Specifications / Remarks
	Panel tuning mode	PC test mode	Test-equipment	Unit	Terminal	Unit	Parts	Method	
1. Setting	1) DC voltage: 13.6V 2) SSG standard modulation [Wide] MOD: 1kHz, DEV: 3kHz [Narrow] MOD: 1kHz, DEV: 1.5kHz								
2. LCD contrast	1) Adj item: [CNTR] Adjust: [***] Press [◀] key to store the adjustment value.	1) Adj item: [LCD Contrast] Press [Apply] button to store the adjustment value.					[Panel tuning mode] [↖],[↗]	Adjust the LCD contrast by looking.	After replacing the LCD align contrast.
3. Receive Assist	1) Adj item: [RAST] Adjust: [***] 2) Adj item: [L RAST]→ [L' RAST]→[C RAST]→ [H' RAST]→[H RAST] Adjust: [***] Press [◀] key to store the adjustment value.	1) Adj item: [Receive Assist] 2) Adj item: [Low], [Low'], [Center], [High'], [High] Press [Apply All] button to store the adjustment value.					[PC test mode] [◀],[▶]	The sub LCD display and [V] indicator on the PC window shows VCO lock voltage. Change the adjustment value to get VCO lock voltage within the limit of the specified voltage.	3.0V±0.1V [PC test mode] Press [Apply All] button to store the adjustment value after all adjustment point was adjusted.
Transmit Assist	1) Adj item: [TAST] Adjust: [***] 2) Adj item: [L TAST]→ [L' TAST]→[C TAST]→ [H' TAST]→[H TAST] Adjust: [***] PTT : ON Press [◀] key to store the adjustment value.	1) Adj item: [Transmit Assist] 2) Adj item: [Low], [Low'], [High'], [High] PTT: Press [Transmit] button. Press [Apply All] button to store the adjustment value.						Note: Confirm the VCO lock voltage approximately 3 seconds after the adjustment value is changed.	
4. RTC oscillation frequency adjust	1) Adj item: [RTC] Adjust: [***]	1) Adj item: [RTC (Real-time clock)]					[▲]	[Panel tuning mode] Press [▲] key. After automatic adjustment adjusted value is displayed on LCD. Press [◀] key to store the adjustment value. [PC test mode] Press [Start] button of "Auto Tuning". Press [Apply] button to store the adjustment value after the automatic adjustment was finished.	Adjustment of the transceiver's internal clock.

ADJUSTMENT

Item	Condition		Measurement			Adjustment			Specifications / Remarks
	Panel tuning mode	PC test mode	Test-equipment	Unit	Terminal	Unit	Parts	Method	
5. Frequency adjust	* The Frequency adjustment can be performed only in PC test mode.	1) Adj item: [Frequency] 2) CH-Sig: 1-1 SSG output : -20dBm (CW (without modulation)) Caution: Perform the frequency adjustment under the following conditions. <ul style="list-style-type: none"> Temperature range of +23°C to +27°C (+73.4°F to +80.6°F). (The temperature is displayed on the Frequency adjustment screen of the KPG-111D and the LCD of the transceiver.) Use an accuracy of 0.001ppm for the SSG. (Use a standard oscillator if necessary.) 	SSG		ANT		[▲]	[PC test mode] Press [Start] button of "Auto Tuning". Press [Apply] button to store the adjustment value after the automatic adjustment was finished.	[PC test mode] "IF20" value = Within 0±12 digits. The value of "IF20" will become around "0" after the adjustment was finished. Frequency is adjusted under receiving condition with SSG.

Transmitter Section

Item	Condition		Measurement			Adjustment			Specifications / Remarks
	Panel tuning mode	PC test mode	Test-equipment	Unit	Terminal	Unit	Parts	Method	
1. High Transmit Power Limit adjust	1) Adj item: [HILMT] Adjust: [*****] 2) Adj item: [L HILMT]→ [L' HILMT]→ [C HILMT]→ [H' HILMT]→ [H HILMT] Adjust: [*****] PTT: ON Press [◀] key to store the adjustment value.	1) Adj item: [High Transmit Power Limit] 2) Adj item: [Low], [Low'], [Center], [High'], [High] PTT: Press [Transmit] button. Press [Apply All] button to store the adjustment value.	Power meter Ammeter		ANT		[Panel tuning mode] [↖],[↗] [PC test mode] [◀],[▶]	48W	±3.0W [PC test mode] Press [Apply All] button to store the adjustment value after all adjustment point was adjusted. CAUTION! Do not attempt to adjust the transceiver's transmit output power beyond its specifications. If the transceiver is adjusted beyond the specifications, it may cause deterioration of the parts reliability and the output power may be lowered suddenly and unstable. The transceiver may be also extremely hot.

ADJUSTMENT

Item	Condition		Measurement			Adjustment			Specifications / Remarks
	Panel tuning mode	PC test mode	Test-equipment	Unit	Terminal	Unit	Parts	Method	
2. Low Transmit Power Limit adjust	1) Adj item: [LOLMT] Adjust: [*****] 2) Adj item: [L LOLMT]→ [L' LOLMT]→ [C LOLMT]→ [H' LOLMT]→ [H LOLMT] Adjust: [*****] PTT: ON Press [◀] key to store the adjustment value.	1) Adj item: [Low Transmit Power Limit] 2) Adj item: [Low], [Low'], [Center], [High'], [High] PTT: Press [Transmit] button. Press [Apply All] button to store the adjustment value.	Power meter Ammeter		ANT		[Panel tuning mode] [↶],[↷] [PC test mode] [◀],[▶]	25.0W	±1.0W [PC test mode] Press [Apply All] button to store the adjustment value after all adjustment point was adjusted. CAUTION! Do not attempt to adjust the transceiver's transmit output power beyond its specifications. If the transceiver is adjusted beyond the specifications, it may cause deterioration of the parts reliability and the output power may be lowered suddenly and unstable. The transceiver may be also extremely hot.
3. High Transmit Power adjust	1) Adj item: [HIPWR] Adjust: [*****] 2) Adj item: [L HIPWR]→ [L' HIPWR]→ [C HIPWR]→ [H' HIPWR]→ [H HIPWR] Adjust: [*****] PTT: ON Press [◀] key to store the adjustment value.	1) Adj item: [High Transmit Power] 2) Adj item: [Low], [Low'], [Center], [High'], [High] PTT: Press [Transmit] button. Press [Apply All] button to store the adjustment value.						45W	±1.0W 13.0A or less [PC test mode] Press [Apply All] button to store the adjustment value after all adjustment point was adjusted.
4. Low Transmit Power adjust	1) Adj item: [LOPWR] Adjust: [*****] 2) Adj item: [L LOPWR]→ [L' LOPWR]→ [C LOPWR]→ [H' LOPWR]→ [H LOPWR] Adjust: [*****] PTT: ON Press [◀] key to store the adjustment value.	1) Adj item: [Low Transmit Power] 2) Adj item: [Low], [Low'], [Center], [High'], [High] PTT: Press [Transmit] button. Press [Apply All] button to store the adjustment value.						10.0W	±1.0W 8.0A or less [PC test mode] Press [Apply All] button to store the adjustment value after all adjustment point was adjusted.

ADJUSTMENT

Item	Condition		Measurement			Adjustment			Specifications / Remarks
	Panel tuning mode	PC test mode	Test-equipment	Unit	Terminal	Unit	Parts	Method	
5. Balance adjust *2	1) Adj item: [BAL] Adjust: [****] Deviation meter LPF: 3kHz HPF: OFF 2) Adj item: [L BAL]→ [L' BAL]→[C BAL]→ [H' BAL]→[H BAL] Adjust: [****] PTT: ON Press [◀] key to store the adjustment value. Sub LCD: Tone frequency [▲] key: Press while transmitting to change 20Hz and 2kHz.	1) Adj item: [Balance] Deviation meter LPF: 3kHz HPF: OFF 2) Adj item: [Low], [Low'], [Center], [High'], [High] PTT: Press [Transmit] button. Press [Apply All] button to store the adjustment value. [2kHz Sine Wave Check box]: Check while transmitting change to 2kHz.	Deviation meter Oscilloscope		ANT		[Panel tuning mode] [↵],[⏏] [PC test mode] [◀],[▶]	The Deviation of 20Hz frequency is fixed. Change the 2kHz adjustment value to become -0.2dB to the deviation of 20Hz within the specified range.	2kHz Tone deviation is within -0.2dB ±0.1dB of 20Hz tone deviation. [PC test mode] Press [Apply All] button to store the adjustment value after all adjustment point was adjusted.
*2: Refer to the "Necessary Deviation adjustment item for each signaling and mode" table on page 35. Balance adjustment is common with the adjustment of all signaling deviation.									
6. Maximum Deviation (NXDN) adjust *3 [Narrow]	1) Adj item: [Nn NDEV] Adjust: [****] Deviation meter LPF: 3kHz HPF: OFF 2) Adj item: [NnL NDEV]→ [NnL' NDEV]→ [NnC NDEV]→ [NnH' NDEV]→ [NnH NDEV] Adjust: [****] PTT: ON Press [◀] key to store the adjustment value.	1) Adj item: [Maximum Deviation (NXDN Narrow)] Deviation meter LPF: 3kHz HPF: OFF 2) Adj item: [Low], [Low'], [Center], [High'], [High] PTT: Press [Transmit] button. Press [Apply All] button to store the adjustment value.	Deviation meter Oscilloscope		ANT		[Panel tuning mode] [↵],[⏏] [PC test mode] [◀],[▶]	3056Hz	±50Hz [PC test mode] Press [Apply All] button to store the adjustment value after all adjustment point was adjusted.
[Very Narrow]	1) Adj item: [Nv NDEV] Adjust: [****] 2) Adj item: [NvL NDEV]→ [NvL' NDEV]→ [NvC NDEV]→ [NvH' NDEV]→ [NvH NDEV] Adjust: [****] PTT: ON Press [◀] key to store the adjustment value.	1) Adj item: [Maximum Deviation (NXDN Very Narrow)] 2) Adj item: [Low], [Low'], [Center], [High'], [High] PTT: Press [Transmit] button. Press [Apply All] button to store the adjustment value.						1337Hz	±50Hz [PC test mode] Press [Apply All] button to store the adjustment value after all adjustment point was adjusted.
7. Maximum Deviation (Analog) adjust *3 [Narrow]	1) Adj item: [An ADEV] Adjust: [****] Deviation meter LPF: 15kHz HPF: OFF 2) Adj item: [AnL ADEV]→ [AnL' ADEV]→ [AnC ADEV]→ [AnH' ADEV]→ [AnH ADEV] Adjust: [****] PTT: ON Press [◀] key to store the adjustment value.	1) Adj item: [Maximum Deviation (Analog Narrow)] Deviation meter LPF: 15kHz HPF: OFF 2) Adj item: [Low], [Low'], [Center], [High'], [High] PTT: Press [Transmit] button. Press [Apply All] button to store the adjustment value.						Write the same adjustment value of "NXDN Deviation [Narrow]" for each adjustment point. Transmit at each adjustment point and check that the Analog deviation is between 2050Hz and 2150Hz. Deviation meter LPF: 15kHz HPF: OFF [Panel tuning mode] PTT: ON [PC test mode] PTT: Press [Transmit] button	2050~2150Hz [PC test mode] Press [Apply All] button to store the adjustment value after all adjustment point was adjusted.

ADJUSTMENT

Item	Condition		Measurement			Adjustment			Specifications / Remarks
	Panel tuning mode	PC test mode	Test-equipment	Unit	Terminal	Unit	Parts	Method	
[Wide]	1) Adj item: [Aw ADEV] Adjust: [*****] 2) Adj item: [AwL ADEV]→ [AwL' ADEV]→ [AwC ADEV]→ [AwH' ADEV]→ [AwH ADEV] Adjust: [*****] PTT: ON Press [◀] key to store the adjustment value.	1) Adj item: [Maximum Deviation (Analog Wide)] 2) Adj item: [Low], [Low'], [Center], [High'], [High] PTT: Press [Transmit] button. Press [Apply All] button to store the adjustment value.	Deviation meter Oscilloscope		ANT		[Panel tuning mode] [↖], [↗] [PC test mode] [◀], [▶]	Write the same adjustment value of "NXDN Deviation [Narrow]" for each adjustment point. Transmit at each adjustment point and check that the Analog deviation is between 4150Hz and 4250Hz. Deviation meter LPF: 15kHz HPF: OFF [Panel tuning mode] PTT: ON [PC test mode] PTT: Press [Transmit] button	4150~4250Hz [PC test mode] Press [Apply All] button to store the adjustment value after all adjustment point was adjusted.
*3: Refer to the "Necessary Deviation adjustment item for each signaling and mode" table on page 35. Analog deviation adjustment (Narrow/Wide) is common with the adjustment of all analog signaling.									
8. QT Deviation adjust *4 [Narrow]	1) Adj item: [An QT] Adjust: [*****] Deviation meter LPF: 3kHz HPF: OFF PTT: ON Press [◀] key to store the adjustment value.	1) Adj item: [QT Deviation (Narrow)] Deviation meter LPF: 3kHz HPF: OFF PTT: Press [Transmit] button. Press [Apply] button to store the adjustment value.	Deviation meter Oscilloscope		ANT		[Panel tuning mode] [↖], [↗] [PC test mode] [◀], [▶]	Write the value as followings. 513 (Reference value)	0.30~0.40kHz
[Wide]	1) Adj item: [Aw QT] Adjust: [*****] PTT: ON Press [◀] key to store the adjustment value.	1) Adj item: [QT Deviation (Wide)] PTT: Press [Transmit] button. Press [Apply] button to store the adjustment value.							0.70~0.80kHz
9. DQT Deviation adjust *4 [Narrow]	1) Adj item: [An DQT] Adjust: [*****] Deviation meter LPF: 3kHz HPF: OFF PTT: ON Press [◀] key to store the adjustment value.	1) Adj item: [DQT Deviation (Narrow)] Deviation meter LPF: 3kHz HPF: OFF PTT: Press [Transmit] button. Press [Apply] button to store the adjustment value.						Write the value as followings. 430 (Reference value)	0.30~0.40kHz
[Wide]	1) Adj item: [Aw DQT] Adjust: [*****] PTT: ON Press [◀] key to store the adjustment value.	1) Adj item: [DQT Deviation (Wide)] PTT: Press [Transmit] button. Press [Apply] button to store the adjustment value.							0.70~0.80kHz

ADJUSTMENT

Item	Condition		Measurement			Adjustment		Specifications / Remarks	
	Panel tuning mode	PC test mode	Test-equipment	Unit	Terminal	Unit	Parts		Method
10. LTR Deviation adjust *4 [Narrow]	1) Adj item: [An LTR] Adjust: [****] Deviation meter LPF: 3kHz HPF: OFF PTT: ON Press [◀] key to store the adjustment value.	1) Adj item: [LTR Deviation (Narrow)] Deviation meter LPF: 3kHz HPF: OFF PTT: Press [Transmit] button. Press [Apply] button to store the adjustment value.	Deviation meter Oscilloscope		ANT		[Panel tuning mode] [↶],[↷] [PC test mode] [◀],[▶]	Write the value as followings. 465 (Reference value)	0.70~0.80kHz
	[Wide]	1) Adj item: [Aw LTR] Adjust: [****] PTT: ON Press [◀] key to store the adjustment value.							1) Adj item: [LTR Deviation (Wide)] PTT: Press [Transmit] button. Press [Apply] button to store the adjustment value.
11. DTMF Deviation adjust *4 [Narrow]	1) Adj item: [An DTMF] Adjust: [****] Deviation meter LPF: 15kHz HPF: OFF PTT: ON Press [◀] key to store the adjustment value.	1) Adj item: [DTMF Deviation (Narrow)] Deviation meter LPF: 15kHz HPF: OFF PTT: Press [Transmit] button. Press [Apply] button to store the adjustment value.						Write the value as followings. 650 (Reference value)	1.45~1.55kHz
	[Wide]	1) Adj item: [Aw DTMF] Adjust: [****] PTT: ON Press [◀] key to store the adjustment value.							1) Adj item: [DTMF Deviation (Wide)] PTT: Press [Transmit] button. Press [Apply] button to store the adjustment value.
12. Single Tone Deviation (2TONE deviation adjust) adjust *4 [Narrow]	1) Adj item: [An TONE] Adjust: [****] Deviation meter LPF: 15kHz HPF: OFF PTT: ON Press [◀] key to store the adjustment value.	1) Adj item: [Single Tone Deviation (Narrow)] Deviation meter LPF: 15kHz HPF: OFF PTT: Press [Transmit] button. Press [Apply] button to store the adjustment value.						Write the value as followings. 513 (Reference value)	1.45~1.55kHz
	[Wide]	1) Adj item: [Aw TONE] Adjust: [****] PTT: ON Press [◀] key to store the adjustment value.							1) Adj item: [Single Tone Deviation (Wide)] PTT: Press [Transmit] button. Press [Apply] button to store the adjustment value.
13. MSK Deviation adjust *4 [Narrow]	1) Adj item: [An MSK] Adjust: [****] Deviation meter LPF: 15kHz HPF: OFF PTT: ON Press [◀] key to store the adjustment value.	1) Adj item: [MSK Deviation (Narrow)] Deviation meter LPF: 15kHz HPF: OFF PTT: Press [Transmit] button. Press [Apply] button to store the adjustment value.						Write the value as followings. 513 (Reference value)	1.45~1.55kHz

ADJUSTMENT

Item	Condition		Measurement			Adjustment			Specifications / Remarks
	Panel tuning mode	PC test mode	Test-equipment	Unit	Terminal	Unit	Parts	Method	
[Wide]	1) Adj item: [Aw MSK] Adjust: [*****] PTT: ON Press [◀] key to store the adjustment value.	1) Adj item: [MSK Deviation (Wide)] PTT: Press [Transmit] button. Press [Apply] button to store the adjustment value.	Deviation meter Oscilloscope		ANT		[Panel tuning mode] [↖],[↗] [PC test mode] [◀],[▶]	Write the value as followings. 513 (Reference value)	2.95~3.05kHz
14. CWID Deviation adjust *4 [Very Narrow]	1) Adj item: [Nv CWID] Adjust: [*****] Deviation meter LPF: 3kHz HPF: OFF PTT: ON Press [◀] key to store the adjustment value.	1) Adj item: [CWID Deviation] Deviation meter LPF: 3kHz HPF: OFF PTT: Press [Transmit] button. Press [Apply] button to store the adjustment value.						Write the value as followings. 375 (Reference value)	0.90~1.10kHz

*4: Refer to the "Necessary Deviation adjustment item for each signaling and mode" table on page 35.

■ Necessary Deviation adjustment for each signaling and mode

The following shows the necessary adjustment items for each signaling deviation. Please read the following table like the following example. In the case of the signaling "QT (Wide)", this signaling is composed of three elements [Balance, Maximum Deviation (Analog Wide) and QT Deviation (Wide)]. Please adjust Balance and Maximum Deviation (Analog Wide) before adjusting QT Deviation (Wide).

Mode	Signaling	Necessary adjustment and order		
		Wide	Narrow	Very Narrow
Analog	Audio	Step1. Balance adjust Step2. Maximum Deviation (Analog Wide)	Step1. Balance adjust Step2. Maximum Deviation (Analog Narrow)	-
	QT	Step1. Balance adjust Step2. Maximum Deviation (Analog Wide) Step3. QT Deviation (Wide)	Step1. Balance adjust Step2. Maximum Deviation (Analog Narrow) Step3. QT Deviation (Narrow)	-
	DQT	Step1. Balance adjust Step2. Maximum Deviation (Analog Wide) Step3. DQT Deviation (Wide)	Step1. Balance adjust Step2. Maximum Deviation (Analog Narrow) Step3. DQT Deviation (Narrow)	-
	LTR	Step1. Balance adjust Step2. Maximum Deviation (Analog Wide) Step3. LTR Deviation (Wide)	Step1. Balance adjust Step2. Maximum Deviation (Analog Narrow) Step3. LTR Deviation (Narrow)	-
	DTMF	Step1. Balance adjust Step2. Maximum Deviation (Analog Wide) Step3. DTMF Deviation (Wide)	Step1. Balance adjust Step2. Maximum Deviation (Analog Narrow) Step3. DTMF Deviation (Narrow)	-
	2TONE	Step1. Balance adjust Step2. Maximum Deviation (Analog Wide) Step3. Single Tone Deviation (Analog Wide)	Step1. Balance adjust Step2. Maximum Deviation (Analog Narrow) Step3. Single Tone Deviation (Analog Narrow)	-
	MSK (FleetSync)	Step1. Balance adjust Step2. Maximum Deviation (Analog Wide) Step3. MSK Deviation (Analog Wide)	Step1. Balance adjust Step2. Maximum Deviation (Analog Narrow) Step3. MSK Deviation (Analog Narrow)	-
NXDN	Audio	-	Step1. Balance adjust Step2. Maximum Deviation (NXDN Narrow)	Step1. Balance adjust Step2. Maximum Deviation (NXDN Very Narrow)
	CWID	-	-	Step1. Balance adjust Step2. Maximum Deviation (Analog Narrow) Step3. CWID Deviation (NXDN Very Narrow)

Balance is common with all the above deviation adjustments. If Balance (Transmitter Section 5) has already adjusted, please skip Step1 and adjust from Step2. Maximum Deviation (Analog Wide/Narrow) is common with all the analog signaling deviations and CWID Deviation (NXDN Very Narrow). If Balance and Maximum Deviation (Analog Wide/Narrow) (Transmitter Section 7) have already adjusted, please skip Step2 and adjust from Step3.

ADJUSTMENT

Receiver Section

Item	Condition		Measurement			Adjustment			Specifications / Remarks
	Panel tuning mode	PC test mode	Test-equipment	Unit	Terminal	Unit	Parts	Method	
1. AF level setting	[Panel test mode] 1) CH-Sig: 1-1 SSG output: -47dBm (1mV) (MOD: 1kHz, Dev: ±1.5kHz)	1) Test Channel Channel: 1 Test Signaling Mode: Analog Signaling: 1 SSG output: -47dBm (1mV) (MOD: 1kHz, Dev: ±1.5kHz)	SSG DVM AF VTVM Dummy load (4Ω)		ANT Ext.SP connec- tor		[Panel tuning mode] [↶],[↷] [PC test mode] [◀],[▶] (Volume Button in PC test mode screen)	Volume Up/Down knob to obtain 2.83V AF output. (2.0W @ 4Ω load)	2.83V±0.3V
2. Sensitivity 1 Adjust (BPF adjust)	1) Adj item: [SENS1] Adjust: [***] 2) Adj item: [L SENS1]→ [L' SENS1]→ [C SENS1]→ [H' SENS1]→ [H SENS1] Adjust: [***] Press [◀] key to store the adjustment value.	1) Adj item: [Sensitivity 1] 2) Adj item: [Low], [Low'], [Center], [High'], [High] Press [Apply All] button to store the adjustment value.					[Panel tuning mode] [↶],[↷] [PC test mode] [◀],[▶]	Write the value as followings (typical value) [L SENS1] / [Low] : 72 [L' SENS1] / [Low'] : 97 [C SENS1] / [Center] : 129 [H' SENS1] / [High'] : 158 [H SENS1] / [High] : 184	Variable-Capacitor Tune voltage is adjusted. (Output voltage ad- justment of IC206) If sensitivity is low, fine-tune the value.
3. Sensitivity 2 Adjust (BPF adjust)	1) Adj item: [SENS2] Adjust: [***] 2) Adj item: [L SENS2]→ [L' SENS2]→ [C SENS2]→ [H' SENS2]→ [H SENS2] Adjust: [***] Press [◀] key to store the adjustment value.	1) Adj item: [Sensitivity 2] 2) Adj item: [Low], [Low'], [Center], [High'], [High] Press [Apply All] button to store the adjustment value.						Write the value as followings [L SENS2] / [Low] : 47 [L' SENS2] / [Low'] : 71 [C SENS2] / [Center] : 113 [H' SENS2] / [High'] : 150 [H SENS2] / [High] : 185	Variable-Capacitor Tune voltage is adjusted. (Output voltage ad- justment of IC205)
4. RSSI reference adjust *5 [Analog Narrow]	1) Adj item: [An RRSSI] Adjust: [***] 2) Adj item: [AnL RRSSI]→ [AnL' RRSSI]→ [AnC RRSSI]→ [AnH' RRSSI]→ [AnH RRSSI] SSG output: 12dB SINAD level -3dB (MOD: 1kHz, Dev: ±1.5kHz)	1) Adj item: [RSSI Reference (Narrow)] 2) Adj item: [Low], [Low'], [Center], [High'], [High] SSG output: 12dB SINAD level -3dB (MOD: 1kHz, Dev: ±1.5kHz)	SSG AF VTVM Oscilloscope Distortion meter Dummy load					[Panel tuning mode] After input signal from SSG, press [◀] key to store the adjustment value. [PC test mode] After input signal from SSG, press [Apply] button to store the adjust- ment value.	
[Analog Wide]	1) Adj item: [Aw RRSSI] Adjust: [***] 2) Adj item: [AwL RRSSI]→ [AwL' RRSSI]→ [AwC RRSSI]→ [AwH' RRSSI]→ [AwH RRSSI] SSG output: 12dB SINAD level -3dB (MOD: 1kHz, Dev: ±3kHz)	1) Adj item: [RSSI Reference (Wide)] 2) Adj item: [Low], [Low'], [Center], [High'], [High] SSG output: 12dB SINAD level -3dB (MOD: 1kHz, Dev: ±3kHz)							

ADJUSTMENT

Item	Condition		Measurement			Adjustment			Specifications / Remarks
	Panel tuning mode	PC test mode	Test-equipment	Unit	Terminal	Unit	Parts	Method	
[NXDN Very Narrow]	1) Adj item: [Nv RRSSI] Adjust: [***] 2) Adj item: [NvL RRSSI]→ [NvL' RRSSI]→ [NvC RRSSI]→ [NvH' RRSSI]→ [NvH RRSSI] SSG output: 12dB SINAD level -3dB (MOD: 1kHz, Dev: ±1.5kHz)	1) Adj item: [RSSI Reference (Very Narrow)] 2) Adj item: [Low], [Low'], [Center], [High'], [High] SSG output: 12dB SINAD level -3dB (MOD: 1kHz, Dev: ±1.5kHz)	SSG AF VTVM Oscilloscope Distortion meter Dummy load		ANT Ext.SP connector		[Panel tuning mode] [Panel tuning mode] [↔],[↔] [PC test mode] [PC test mode] [←],[→]	[Panel tuning mode] After input signal from SSG, press [<] key to store the adjustment value. [PC test mode] After input signal from SSG, press [Apply] button to store the adjustment value.	Adjust with the analog signal.
*5: Because "RSSI reference adjust" of NXDN Narrow is adjusted by adjusting "RSSI reference adjust [Analog Narrow]", it is not necessary to adjust "RSSI reference adjust" of NXDN Narrow.									
5. Open Squelch adjust *6 (Squelch level 5 adjust) [Analog Narrow]	1) Adj item: [An SQL] Adjust: [***] 2) Adj item: [AnL SQL]→ [AnL' SQL]→ [AnC SQL]→ [AnH' SQL]→ [AnH SQL] SSG output: 12dB SINAD level +1dB (MOD: 1kHz, Dev: ±1.5kHz)	1) Adj item: [Open Squelch (Narrow)] 2) Adj item: [Low], [Low'], [Center], [High'], [High] SSG output: 12dB SINAD level +1dB (MOD: 1kHz, Dev: ±1.5kHz)	SSG AF VTVM Oscilloscope Distortion meter Dummy load		ANT Ext.SP connector		[Panel tuning mode] After input signal from SSG, press [<] key to store the adjustment value. [PC test mode] After input signal from SSG, press [Apply] button to store the adjustment value.		"Open Squelch" will not be adjusted correctly if MOD and Deviation are wrong.
[Analog Wide]	1) Adj item: [Aw SQL] Adjust: [***] 2) Adj item: [AwL SQL]→ [AwL' SQL]→ [AwC SQL]→ [AwH' SQL]→ [AwH SQL] SSG output: 12dB SINAD level +1dB (MOD: 1kHz, Dev: ±3kHz)	1) Adj item: [Open Squelch (Wide)] 2) Adj item: [Low], [Low'], [Center], [High'], [High] SSG output: 12dB SINAD level +1dB (MOD: 1kHz, Dev: ±3kHz)							
[NXDN Very Narrow]	1) Adj item: [Nv SQL] Adjust: [***] 2) Adj item: [NvL SQL]→ [NvL' SQL]→ [NvC SQL]→ [NvH' SQL]→ [NvH SQL] SSG output: 12dB SINAD level -2dB (MOD: non)	1) Adj item: [Open Squelch (Very Narrow)] 2) Adj item: [Low], [Low'], [Center], [High'], [High] SSG output: 12dB SINAD level -2dB (MOD: non)							Adjust with the analog signal. This item is adjusted under the condition that MOD is "non" due to the circuit configuration.
*6: Because "Open squelch adjust" of NXDN Narrow is adjusted by adjusting "Open squelch adjust [Analog Narrow]", it is not necessary to adjust "Open squelch adjust" of NXDN Narrow.									

ADJUSTMENT

Item	Condition		Measurement			Adjustment			Specifications / Remarks
	Panel tuning mode	PC test mode	Test-equipment	Unit	Terminal	Unit	Parts	Method	
6. Low RSSI at -118dBm adjust *7 [Analog Narrow]	1) Adj item: [An LRSSI] Adjust: [***] 2) Adj item: [AnL LRSSI]→ [AnL' LRSSI]→ [AnC LRSSI]→ [AnH' LRSSI]→ [AnH LRSSI] SSG output: -118dBm (0.28μV) (MOD: 1kHz, Dev: ±1.5kHz)	1) Adj item: [Low RSSI (Narrow)] 2) Adj item: [Low], [Low'], [Center], [High'], [High] SSG output: -118dBm (0.28μV) (MOD: 1kHz, Dev: ±1.5kHz)	SSG		ANT Ext.SP connector			[Panel tuning mode] After input signal from SSG, press [<] key to store the adjustment value. [PC test mode] After input signal from SSG, press [Apply] button to store the adjustment value.	
[Analog Wide]	1) Adj item: [Aw LRSSI] Adjust: [***] 2) Adj item: [AwL LRSSI]→ [AwL' LRSSI]→ [AwC LRSSI]→ [AwH' LRSSI]→ [AwH LRSSI] SSG output: -118dBm (0.28μV) (MOD: 1kHz, Dev: ±3kHz)	1) Adj item: [Low RSSI (Wide)] 2) Adj item: [Low], [Low'], [Center], [High'], [High] SSG output: -118dBm (0.28μV) (MOD: 1kHz, Dev: ±3kHz)							
[NXDN Very Narrow]	1) Adj item: [Nv LRSSI] Adjust: [***] 2) Adj item: [NvL LRSSI]→ [NvL' LRSSI]→ [NvC LRSSI]→ [NvH' LRSSI]→ [NvH LRSSI] SSG output: -118dBm (0.28μV) (MOD: 1kHz, Dev: ±1.5kHz)	1) Adj item: [Low RSSI (Very Narrow)] 2) Adj item: [Low], [Low'], [Center], [High'], [High] SSG output: -118dBm (0.28μV) (MOD: 1kHz, Dev: ±1.5kHz)							Adjust with the analog signal.
*7: Because "Low RSSI at -118dBm adjust" of NXDN Narrow is adjusted by adjusting "Low RSSI at -118dBm adjust [Analog Narrow]", it is not necessary to adjust "Low RSSI at -118dBm adjust" of NXDN Narrow.									
7. High RSSI at -80dBm adjust *8 [Analog Narrow]	1) Adj item: [An HRSSI] Adjust: [***] 2) Adj item: [AnL HRSSI]→ [AnL' HRSSI]→ [AnC HRSSI]→ [AnH' HRSSI]→ [AnH HRSSI] SSG output: -80dBm (22.4μV) (MOD: 1kHz, Dev: ±1.5kHz)	1) Adj item: [High RSSI (Narrow)] 2) Adj item: [Low], [Low'], [Center], [High'], [High] SSG output: -80dBm (22.4μV) (MOD: 1kHz, Dev: ±1.5kHz)	SSG		ANT Ext.SP connector			[Panel tuning mode] After input signal from SSG, press [<] key to store the adjustment value. [PC test mode] After input signal from SSG, press [Apply] button to store the adjustment value.	

ADJUSTMENT

Item	Condition		Measurement			Adjustment			Specifications / Remarks
	Panel tuning mode	PC test mode	Test-equipment	Unit	Terminal	Unit	Parts	Method	
[Analog Wide]	1) Adj item: [Aw HRSSI] Adjust: [***] 2) Adj item: [AwL HRSSI]→ [AwL' HRSSI]→ [AwC HRSSI]→ [AwH' HRSSI]→ [AwH HRSSI] SSG output: -80dBm (22.4μV) (MOD: 1kHz, Dev: ±3kHz)	1) Adj item: [High RSSI (Wide)] 2) Adj item: [Low], [Low'], [Center], [High'], [High] SSG output: -80dBm (22.4μV) (MOD: 1kHz, Dev: ±3kHz)	SSG		ANT Ext.SP connec- tor			[Panel tuning mode] After input signal from SSG, press [<] key to store the adjustment value. [PC test mode] After input signal from SSG, press [Apply] button to store the adjustment value.	
[NXDN Very Narrow]	1) Adj item: [Nv HRSSI] Adjust: [***] 2) Adj item: [NvL HRSSI]→ [NvL' HRSSI]→ [NvC HRSSI]→ [NvH' HRSSI]→ [NvH HRSSI] SSG output: -80dBm (22.4μV) (MOD: 1kHz, Dev: ±1.5kHz)	1) Adj item: [High RSSI (Very Narrow)] 2) Adj item: [Low], [Low'], [Center], [High'], [High] SSG output: -80dBm (22.4μV) (MOD: 1kHz, Dev: ±1.5kHz)							Adjust with the analog signal.
*8: Because "RSSI at -80dBm adjust" of NXDN Narrow is adjusted by adjusting "RSSI at -80dBm adjust [Analog Narrow]", it is not necessary to adjust "RSSI at -80dBm adjust" of NXDN Narrow.									
8. Tight Squelch adjust (Squelch level 9 adjust) [Analog Narrow]	1) Adj item: [An SQLT] Adjust: [***] 2) Adj item: [AnL SQLT]→ [AnL' SQLT]→ [AnC SQLT]→ [AnH' SQLT]→ [AnH SQLT] SSG output: 12dB SINAD level +6dB (MOD: 1kHz, Dev: ±1.5kHz)	1) Adj item: [Tight Squelch (Narrow)] 2) Adj item: [Low], [Low'], [Center], [High'], [High] SSG output: 12dB SINAD level +6dB (MOD: 1kHz, Dev: ±1.5kHz)	SSG AF VTVM Oscillo- scope Distortion meter Dummy load		ANT Ext.SP connec- tor			[Panel tuning mode] After input signal from SSG, press [<] key to store the adjustment value. [PC test mode] After input signal from SSG, press [Apply] button to store the adjustment value.	
[Analog Wide]	1) Adj item: [Aw SQLT] Adjust: [***] 2) Adj item: [AwL SQLT]→ [AwL' SQLT]→ [AwC SQLT]→ [AwH' SQLT]→ [AwH SQLT] SSG output: 12dB SINAD level +6dB (MOD: 1kHz, Dev: ±3kHz)	1) Adj item: [Tight Squelch (Wide)] 2) Adj item: [Low], [Low'], [Center], [High'], [High] SSG output: 12dB SINAD level +6dB (MOD: 1kHz, Dev: ±3kHz)							

NX-800H PC BOARD

DISPLAY UNIT (X54-3680-10) Component side view (J79-0157-39)

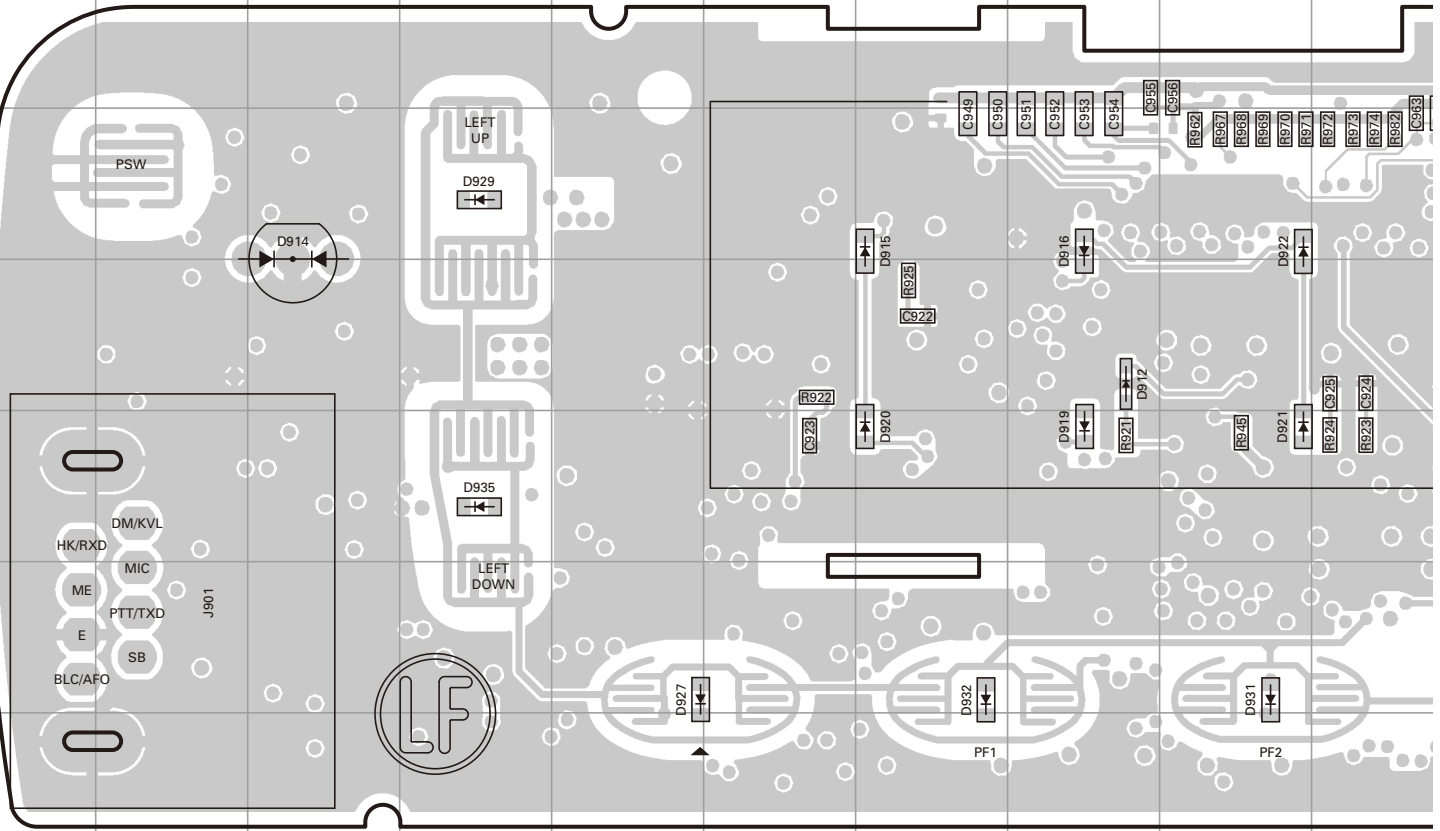

DISPLAY UNIT (X54-3680-10) Foil side view (J79-0157-39)

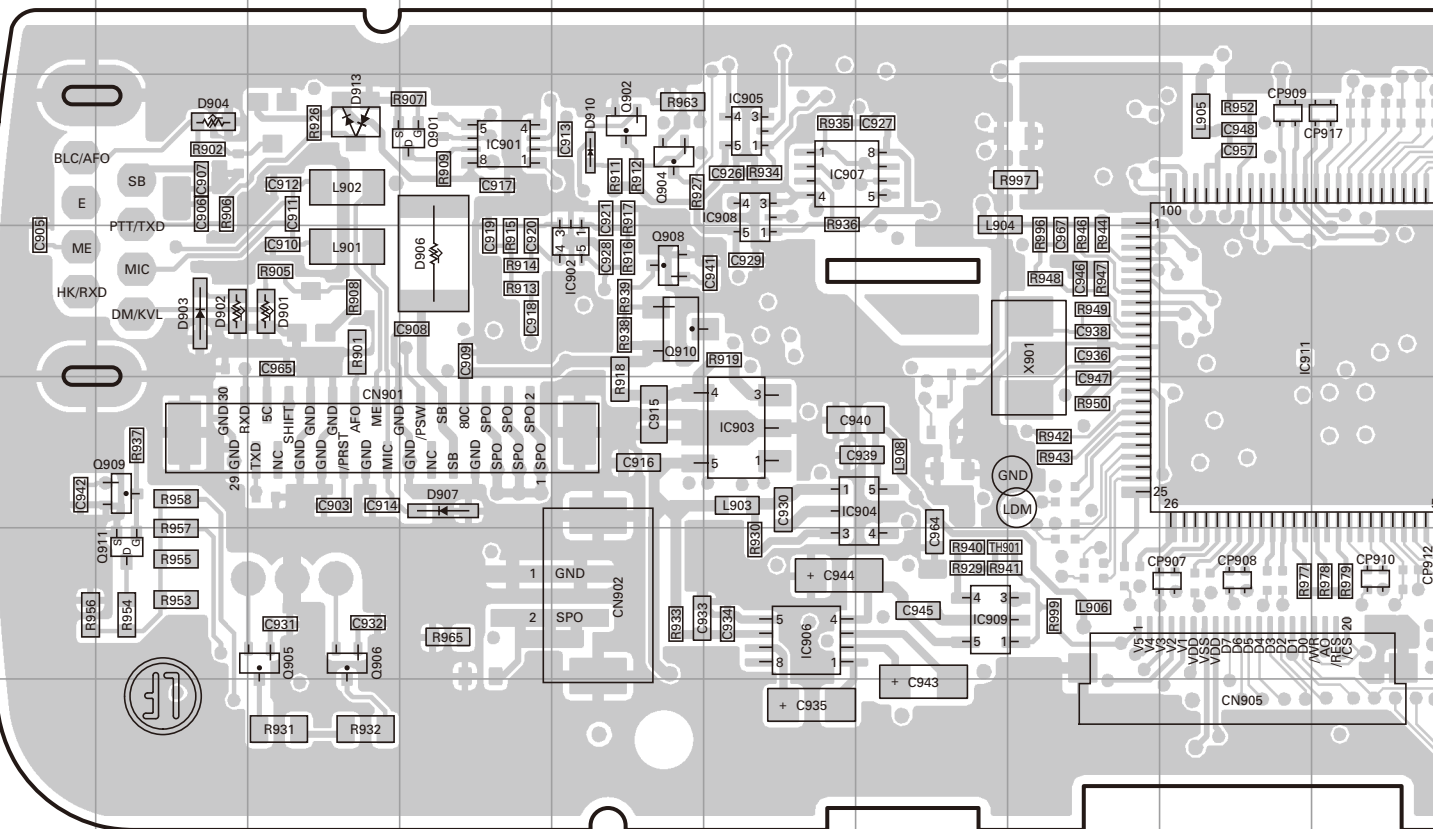

PC BOARD NX-800H

DISPLAY UNIT (X54-3680-10) Component side view (J79-0157-39)

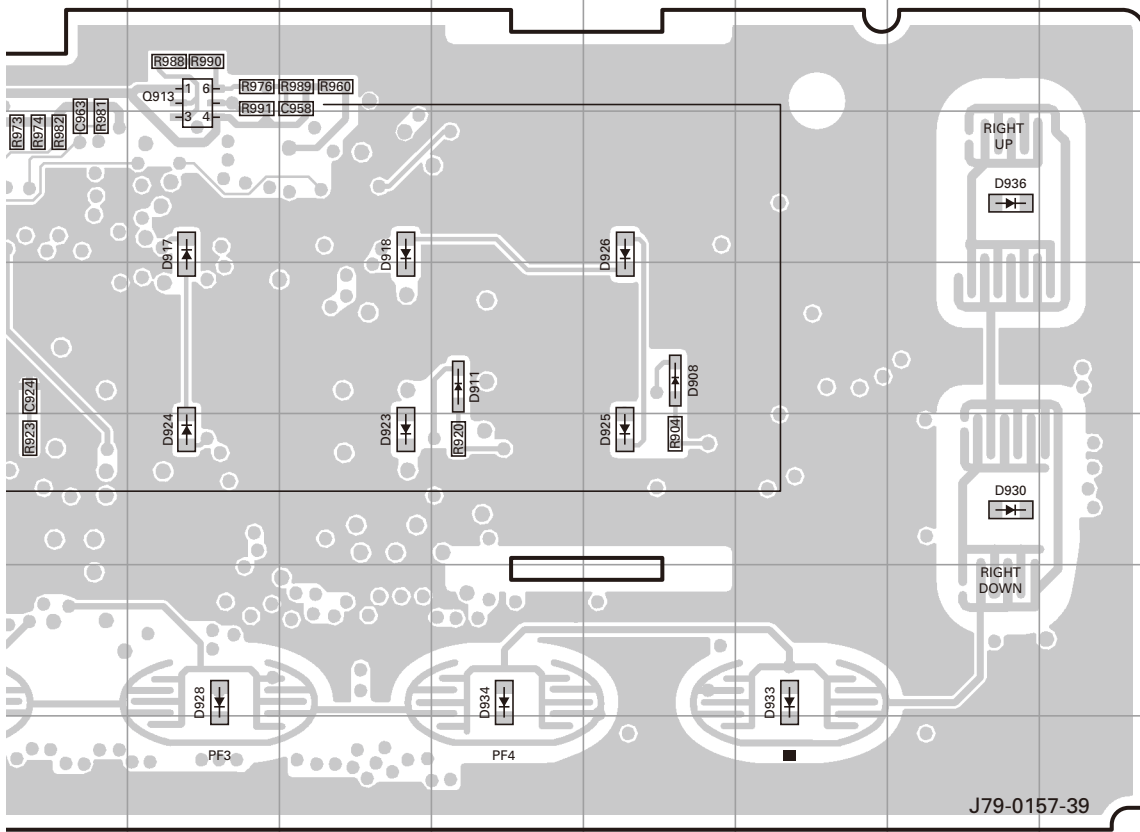

Ref. No.	Address	Ref. No.	Address
Q913	2K	D924	5K
D908	4N	D925	5N
D911	4M	D926	3M
D912	4H	D927	6E
D914	3C	D928	6K
D915	3G	D929	3D
D916	3H	D930	5P
D917	3K	D931	6I
D918	3L	D932	6G
D919	5H	D933	6O
D920	5G	D934	6M
D921	5I	D935	5D
D922	3I	D936	3P
D923	5L		

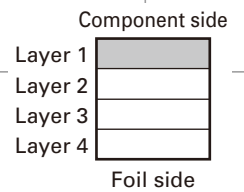

DISPLAY UNIT (X54-3680-10) Foil side view (J79-0157-39)

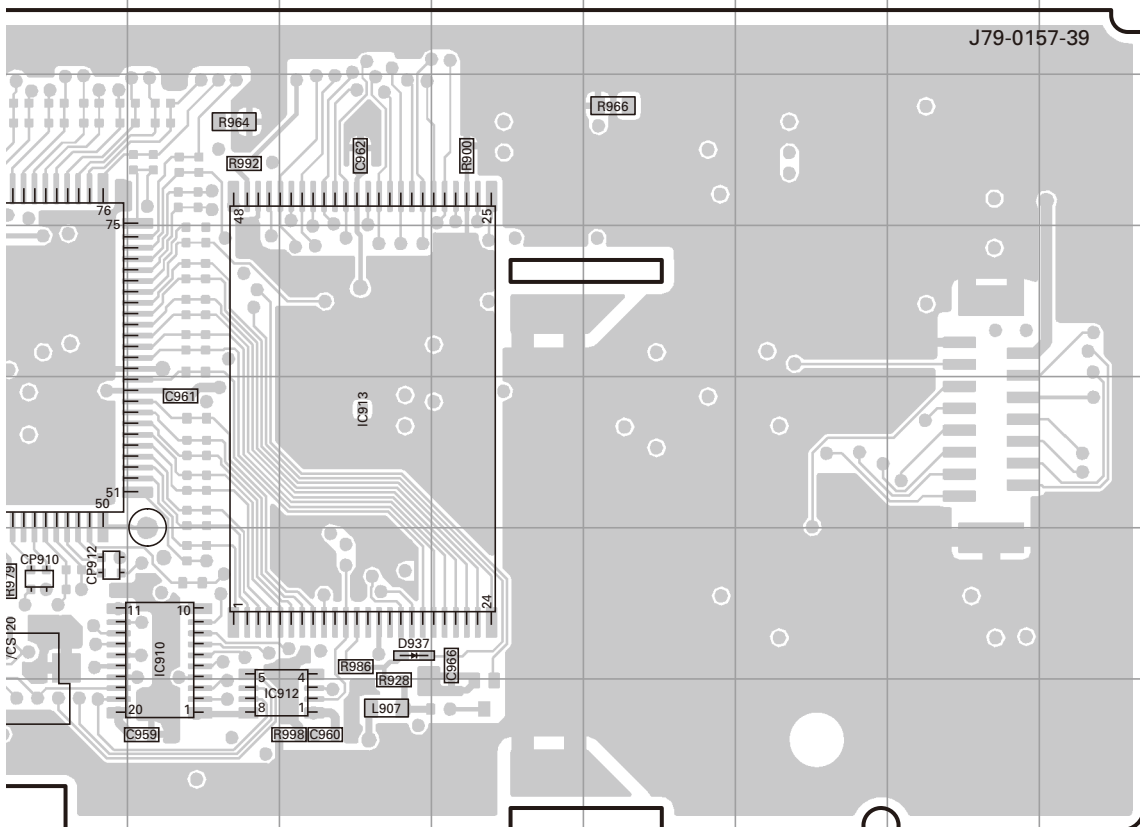

Ref. No.	Address	Ref. No.	Address
IC901	9D	Q905	12C
IC902	10E	Q906	12C
IC903	11F	Q908	10E
IC904	11G	Q909	11B
IC905	9F	Q910	10E
IC906	12F	Q911	12B
IC907	9F	D901	10C
IC908	9F	D902	10B
IC909	12G	D903	10B
IC910	12K	D904	9B
IC911	10I	D906	10D
IC912	13L	D907	11D
IC913	11L	D910	9E
Q901	9D	D913	9C
Q902	9E	D937	12L
Q904	9E		

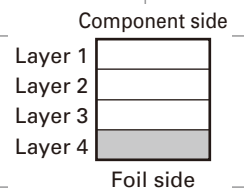

NX-800H PC BOARD

TX-RX UNIT (X57-7750-18) (A/2) Component side view (J79-0208-19 A/2)

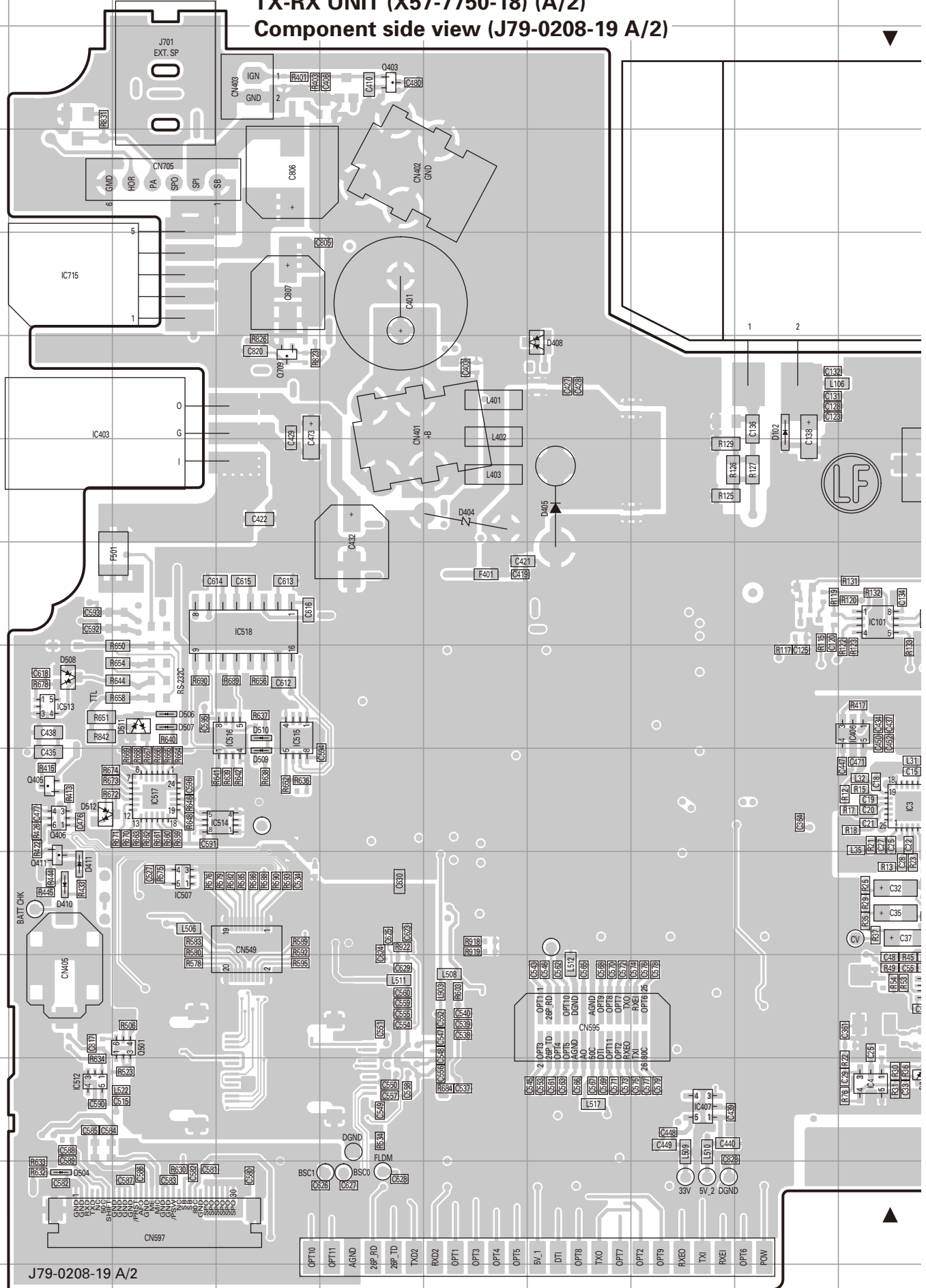

J79-0208-19 A/2

- OPT10
- OPT11
- AGND
- 28P_RD
- 28P_TD
- TXD2
- RXD2
- OPT1
- OPT3
- OPT4
- OPT5
- 5V_1
- DT1
- OPT8
- TX0
- OPT7
- OPT2
- OPT9
- RXED
- TX1
- RXE1
- OPT6
- POW

NX-800H PC BOARD

TX-RX UNIT (X57-7750-18) (A/2) Foil side view (J79-0208-19 A/2)

Ref. No.	Address	Ref. No.	Address	Ref. No.	Address
IC204	11F	Q6	10J	D4	11J
IC401	7M	Q7	10K	D7	11H
IC402	6N	Q8	10J	D8	11J
IC404	6P	Q9	10I	D9	11H
IC405	5N	Q10	10I	D10	11I
IC408	5M	Q101	7I	D11	11J
IC409	7N	Q102	7J	D12	11I
IC410	12J	Q203	8E	D14	11J
IC501	12P	Q204	9D	D101	9H
IC502	10Q	Q205	10D	D103	5F
IC503	12Q	Q208	10G	D104	6F
IC504	10N	Q210	7G	D106	6E
IC505	10P	Q401	3P	D108	6D
IC506	13P	Q402	4P	D109	5D
IC508	10O	Q404	4P	D110	4D
IC509	9P	Q407	5P	D201	10E
IC510	12O	Q408	5P	D205	9H
IC511	9O	Q409	7O	D212	7E
IC701	12M	Q410	7N	D213	7E
IC702	8N	Q412	6N	D216	7D
IC703	12L	Q413	5P	D401	3O
IC704	10M	Q414	5P	D403	4P
IC705	12L	Q415	7O	D406	3P
IC706	8M	Q416	5N	D407	4N
IC707	12M	Q417	12I	D409	4N
IC708	8N	Q701	12K	D412	5N
IC709	8O	Q702	11L	D501	13O
IC710	11M	Q703	12M	D502	13O
IC711	11L	Q704	7P	D503	9O
IC712	9L	Q705	8P	D702	11L
IC713	11K	Q706	8R	D703	11L
IC714	11L	Q707	8R	D704	7O
Q3	9I	Q708	10L	D705	8O
Q4	9J	Q710	5Q	D706	9L
Q5	10I	D3	11I	D707	9M

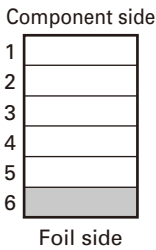
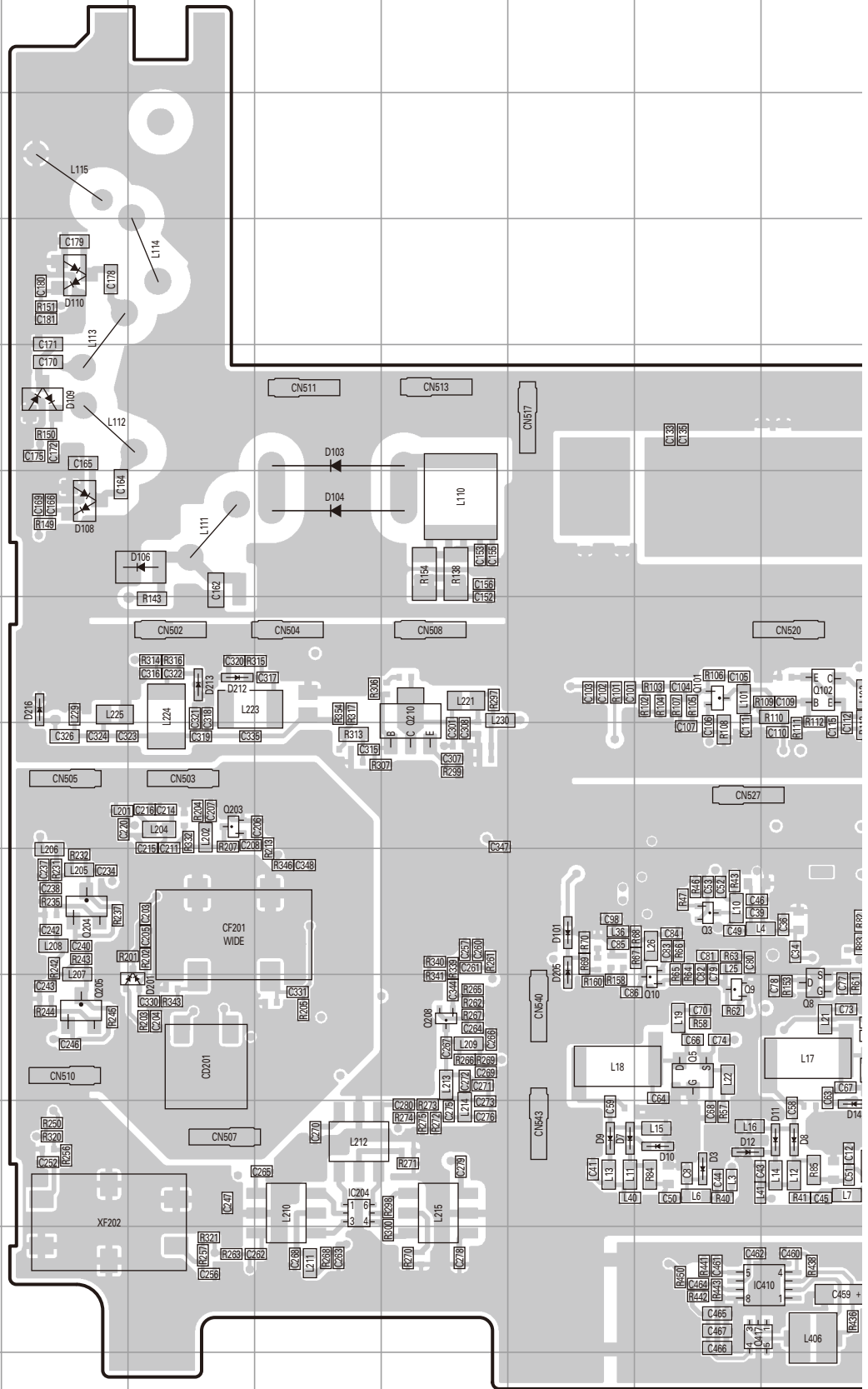

NX-800H PC BOARD

TX-RX UNIT (X57-7750-18) (B/2) Component side view (J79-0208-19 B/2)

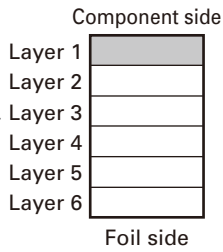
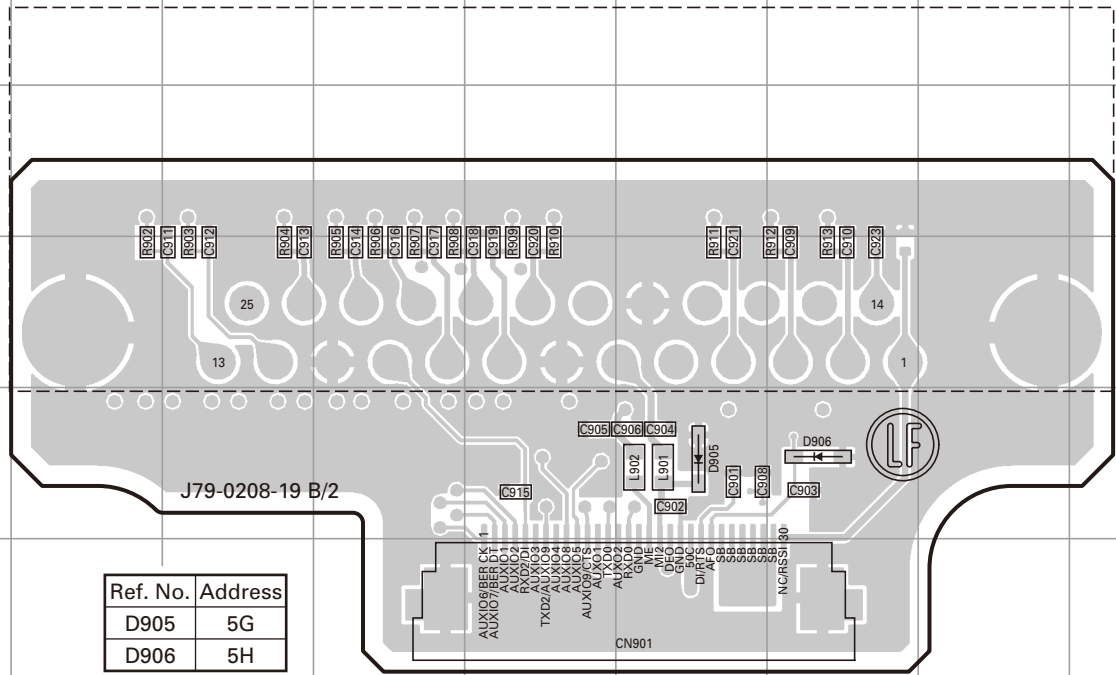

Ref. No.	Address
D905	5G
D906	5H

TX-RX UNIT (X57-7750-18) (B/2) Foil side view (J79-0208-19 B/2)

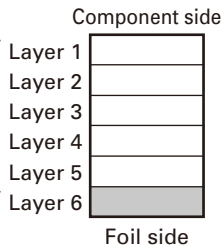
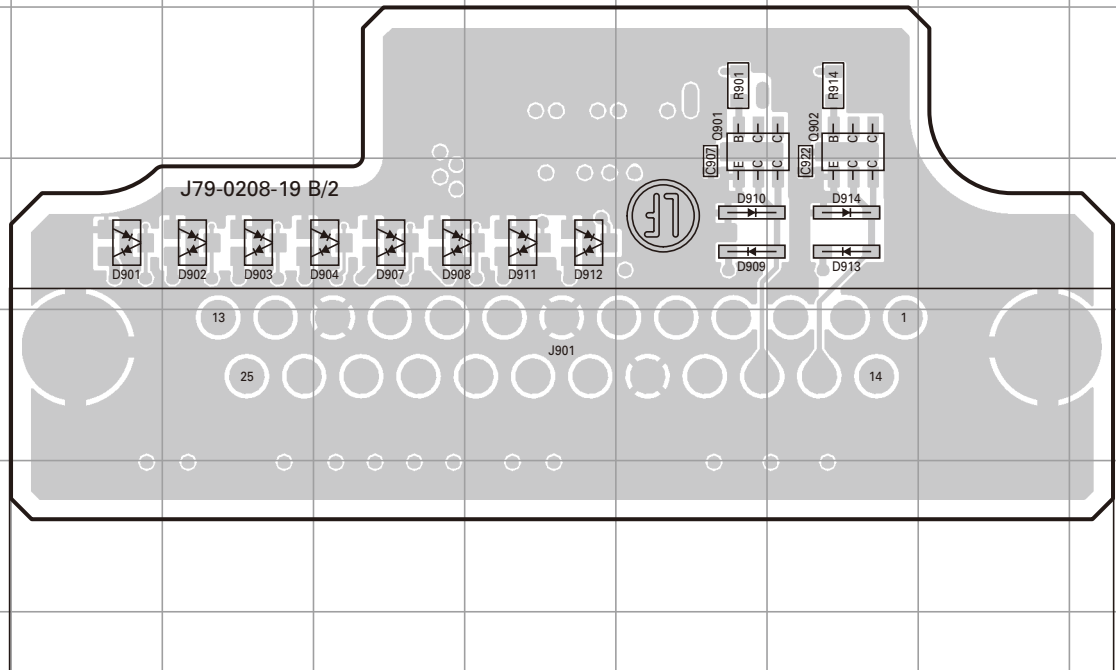

Ref. No.	Address	Ref. No.	Address	Ref. No.	Address
Q901	8G	D904	9E	D911	9F
Q902	8H	D907	9E	D912	9F
D901	9C	D908	9E	D913	9H
D902	9D	D909	9G	D914	9H
D903	9D	D910	9G		

NX-800H SCHEMATIC DIAGRAM

TX-RX UNIT (X57-7750-18) (A/2)

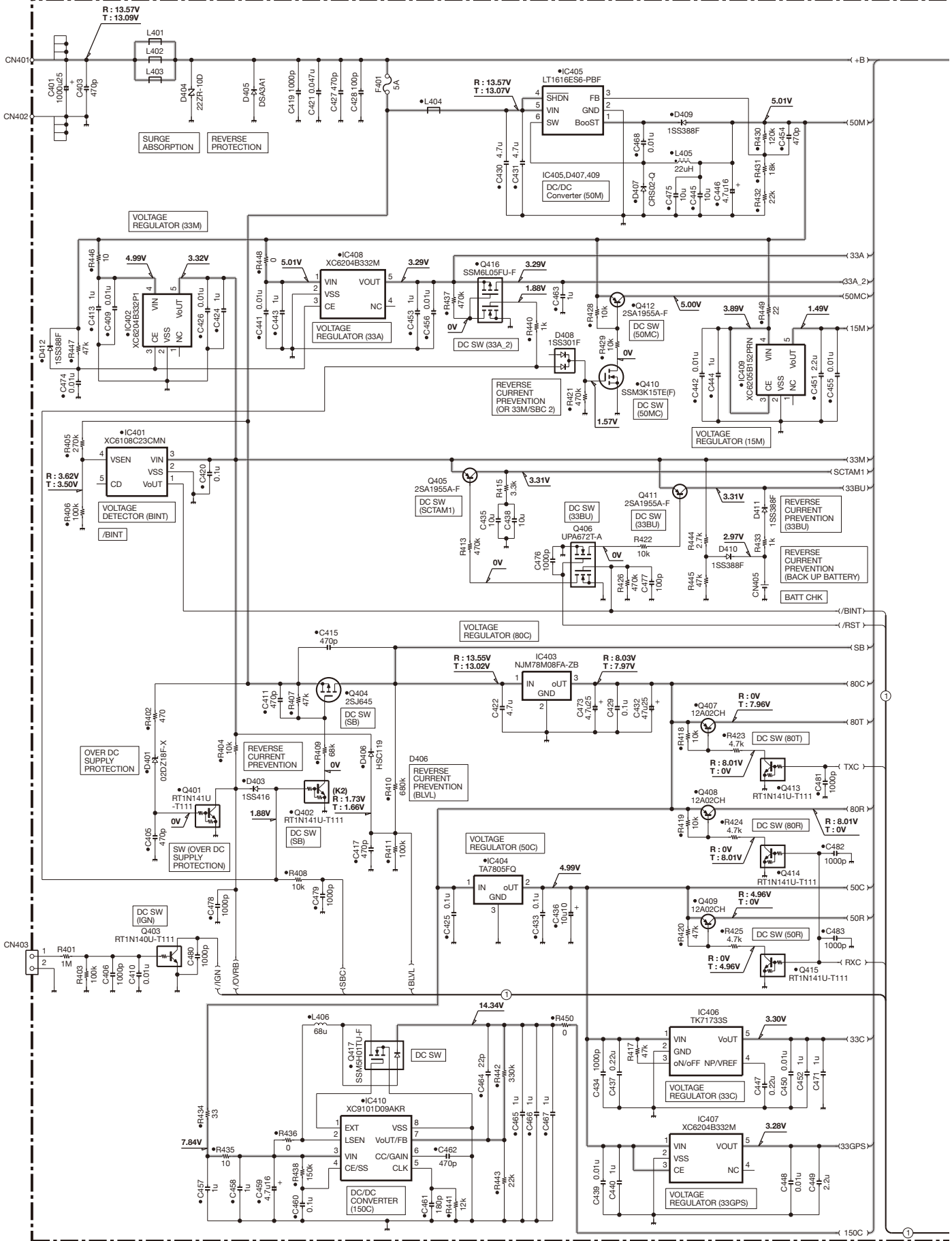

SCHEMATIC DIAGRAM NX-800H

TX-RX UNIT (X57-7750-18) (A/2)

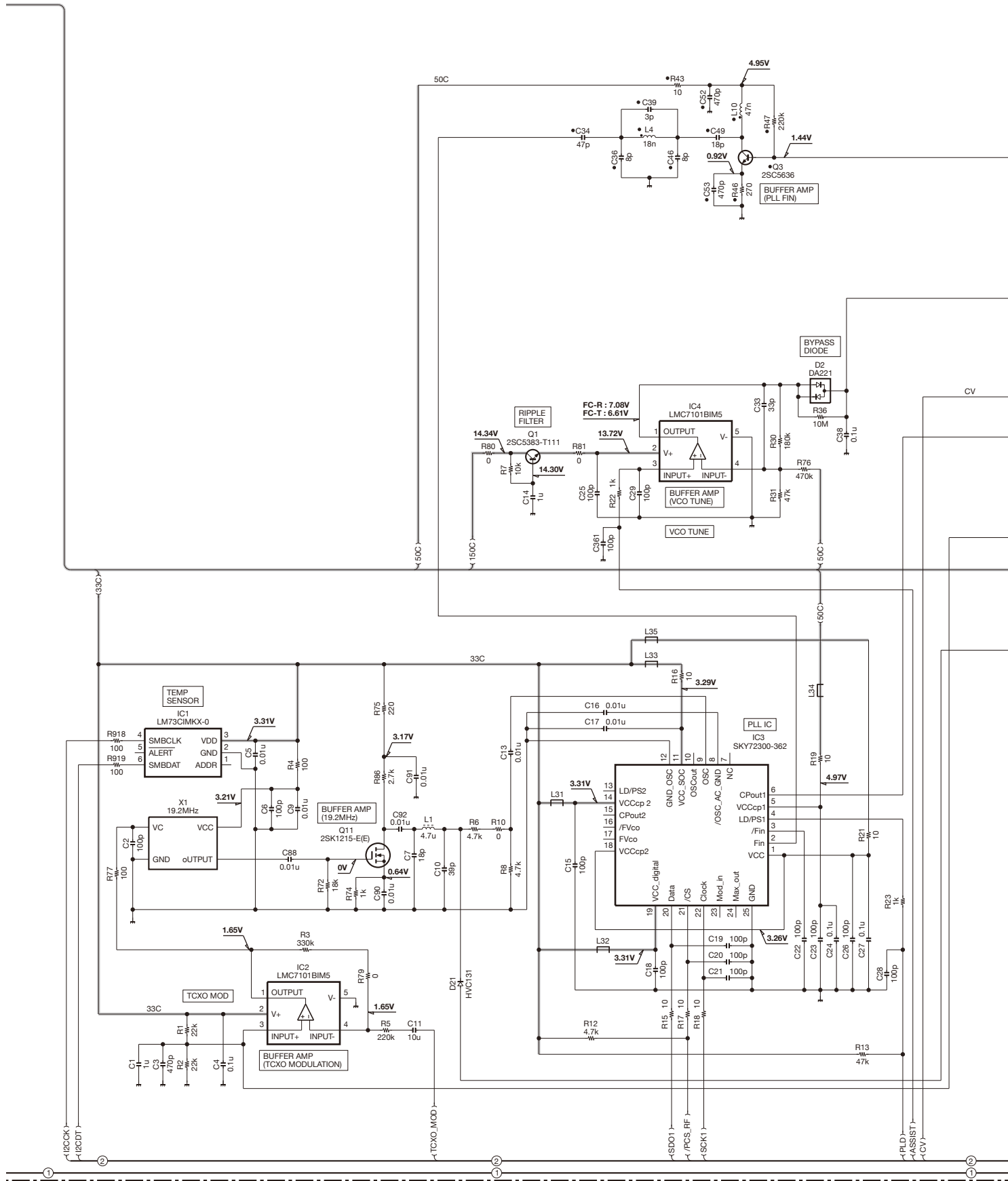

NX-800H SCHEMATIC DIAGRAM

TX-RX UNIT (X57-7750-18) (A/2)

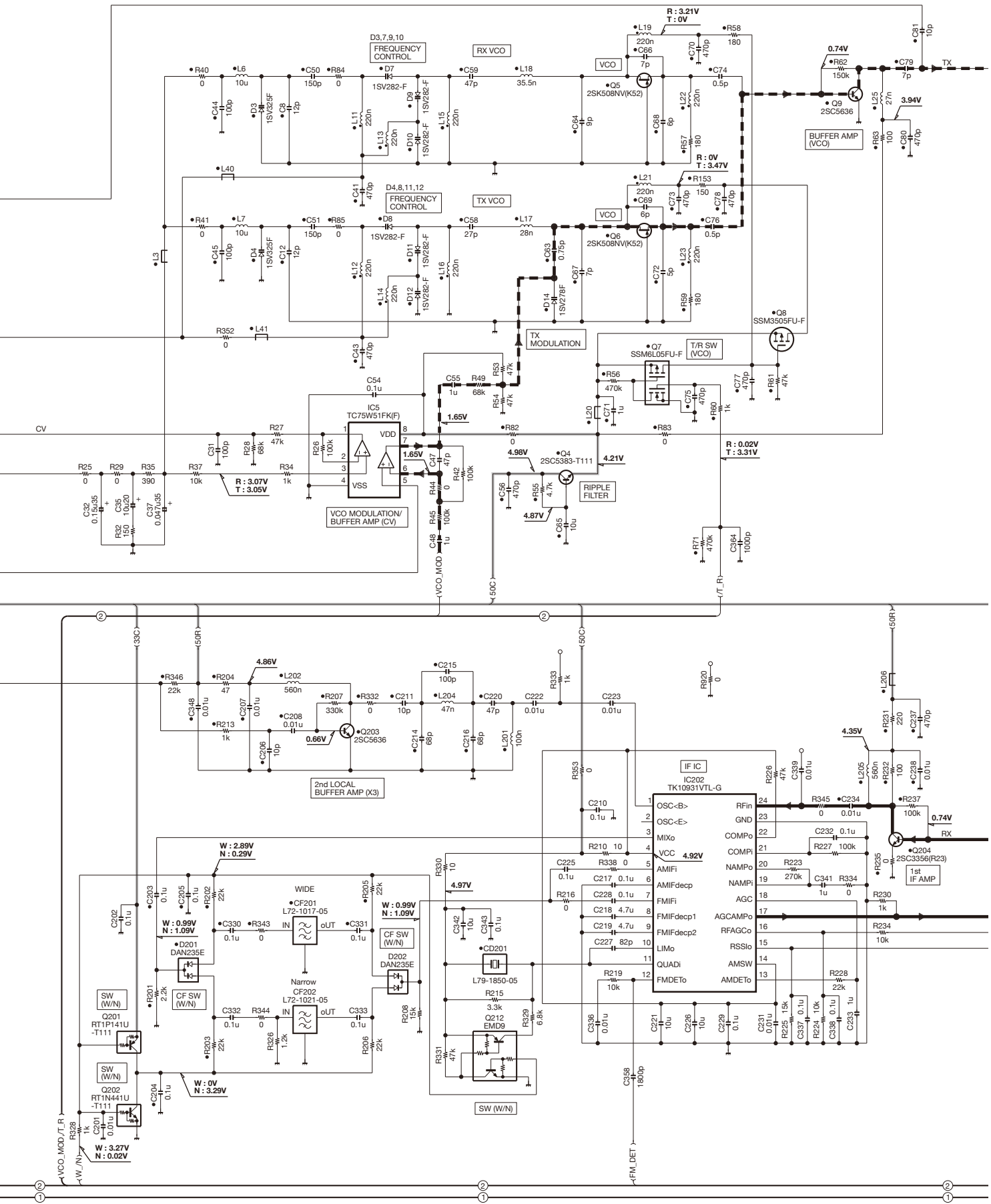

SCHEMATIC DIAGRAM NX-800H

TX-RX UNIT (X57-7750-18) (A/2)

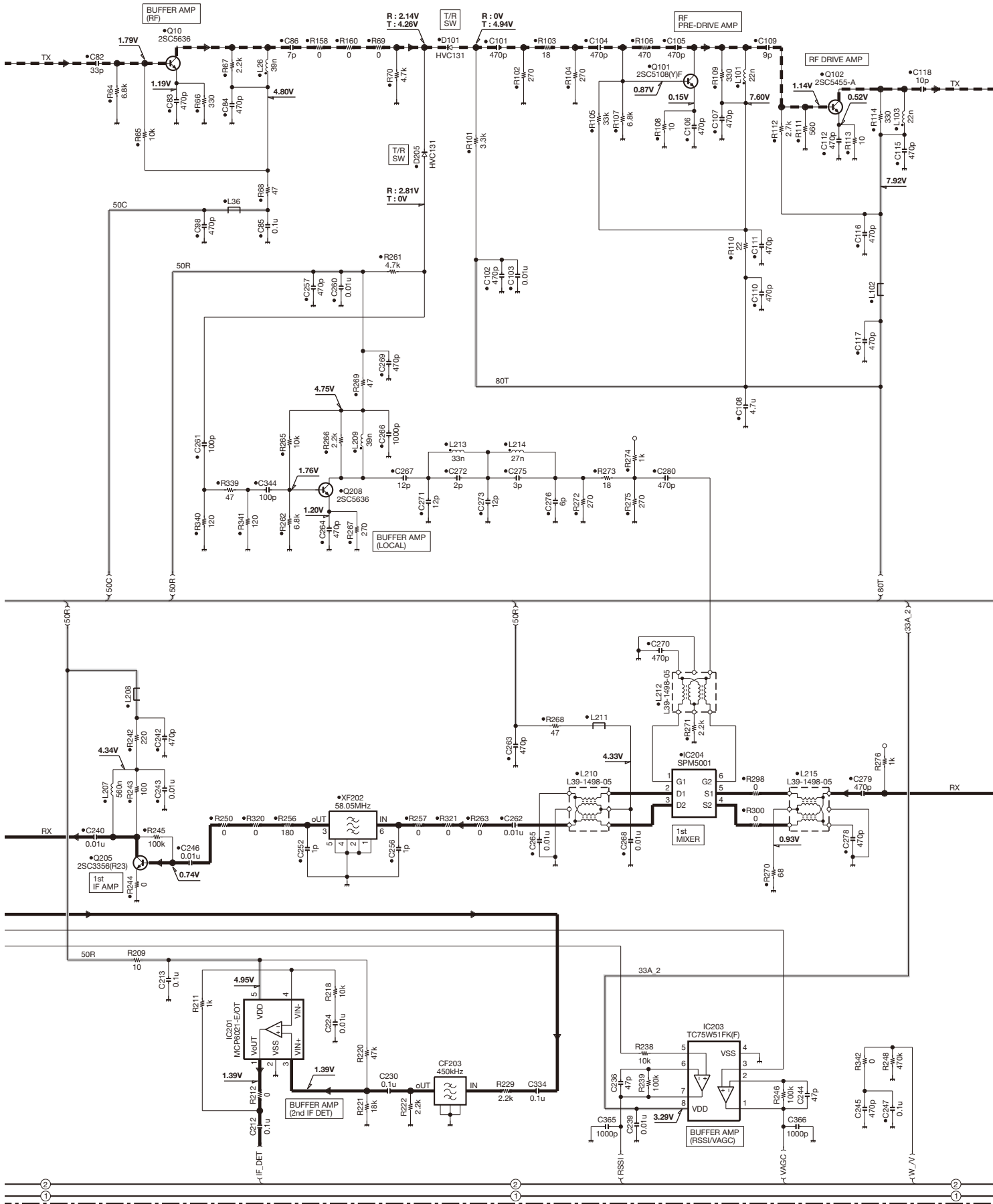

SCHEMATIC DIAGRAM NX-800H

TX-RX UNIT (X57-7750-18) (A/2)

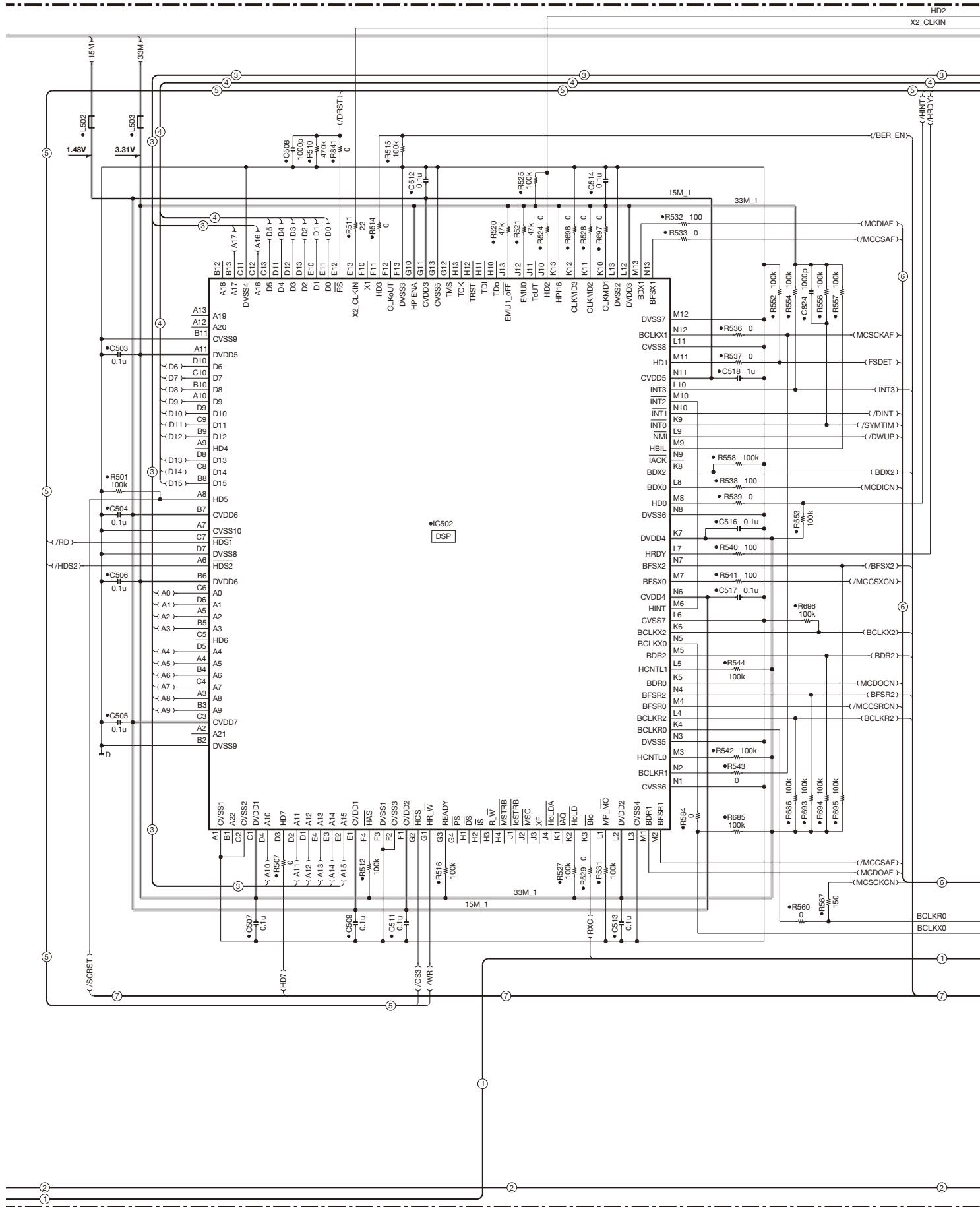

NX-800H SCHEMATIC DIAGRAM

TX-RX UNIT (X57-7750-18) (A/2)

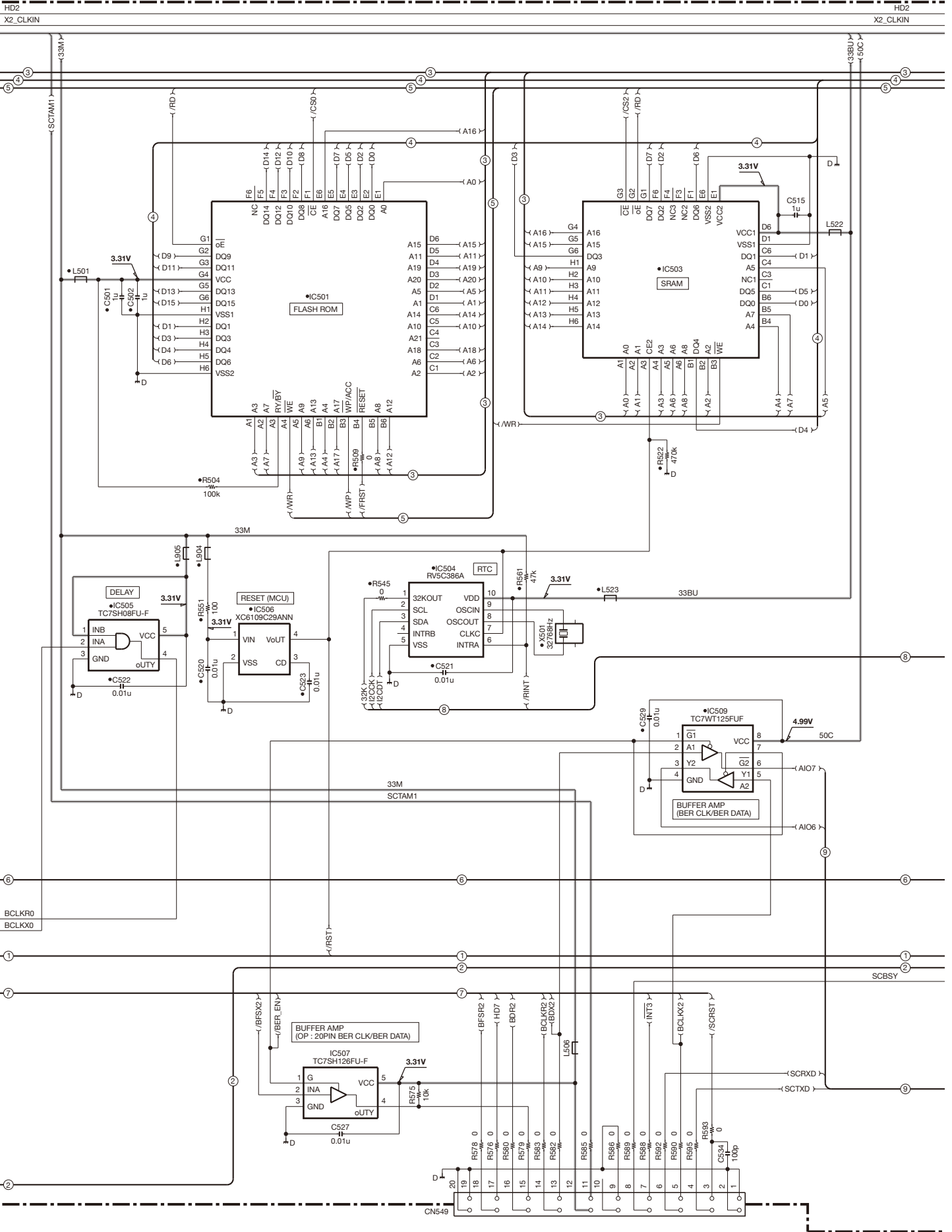

SCHEMATIC DIAGRAM NX-800H

TX-RX UNIT (X57-7750-18) (A/2)

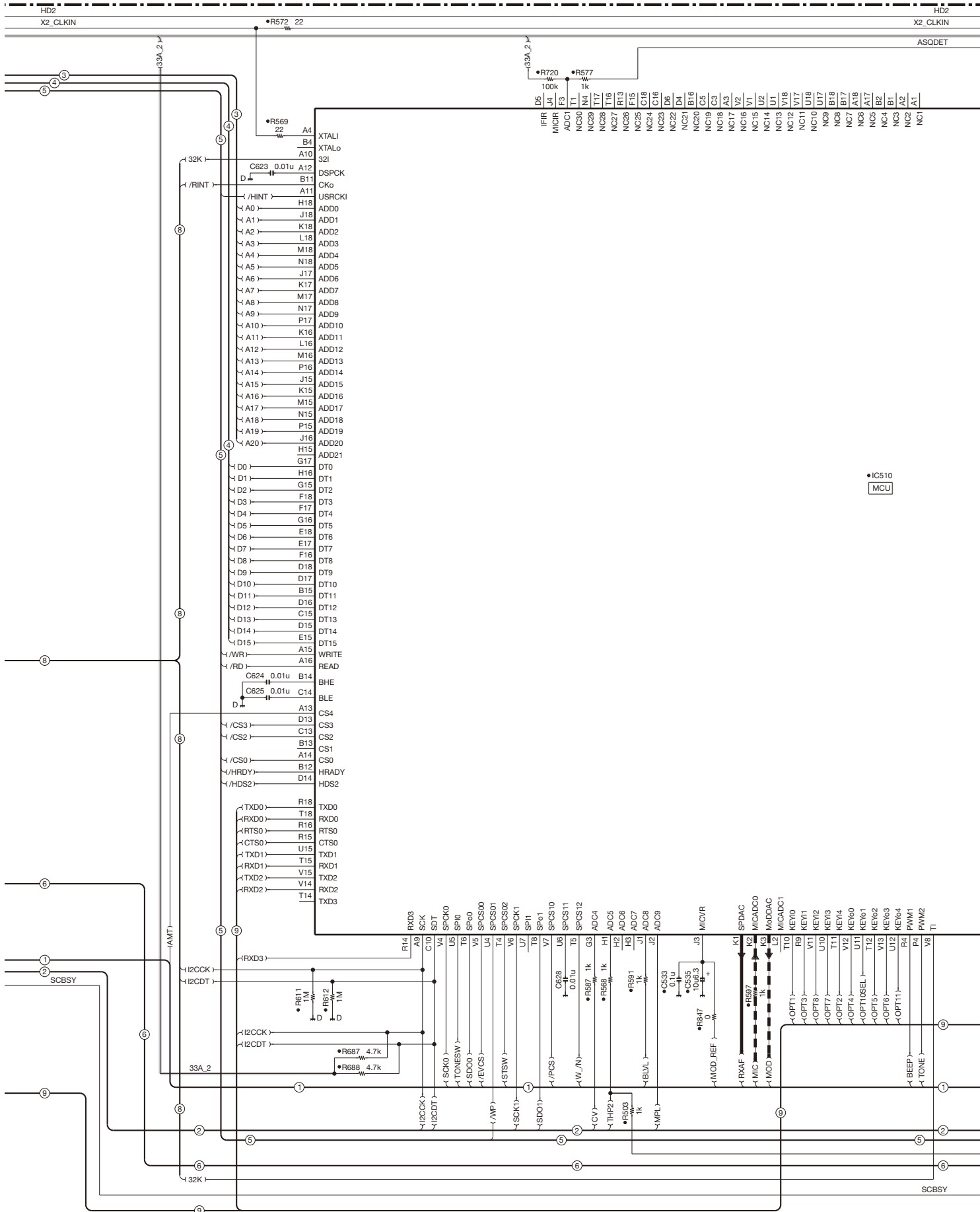

NX-800H SCHEMATIC DIAGRAM

TX-RX UNIT (X57-7750-18) (A/2)

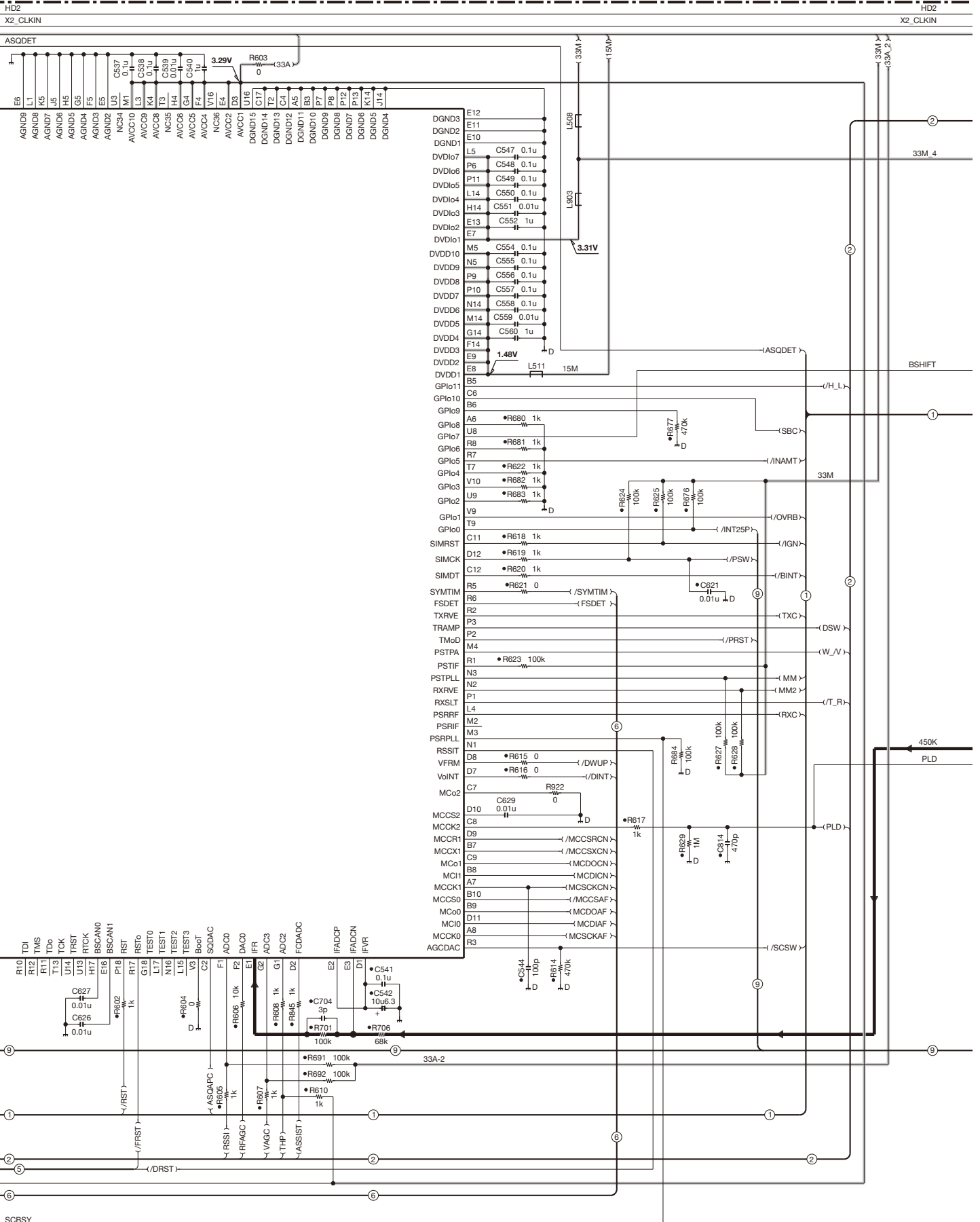

SCHEMATIC DIAGRAM NX-800H

TX-RX UNIT (X57-7750-18) (A/2)

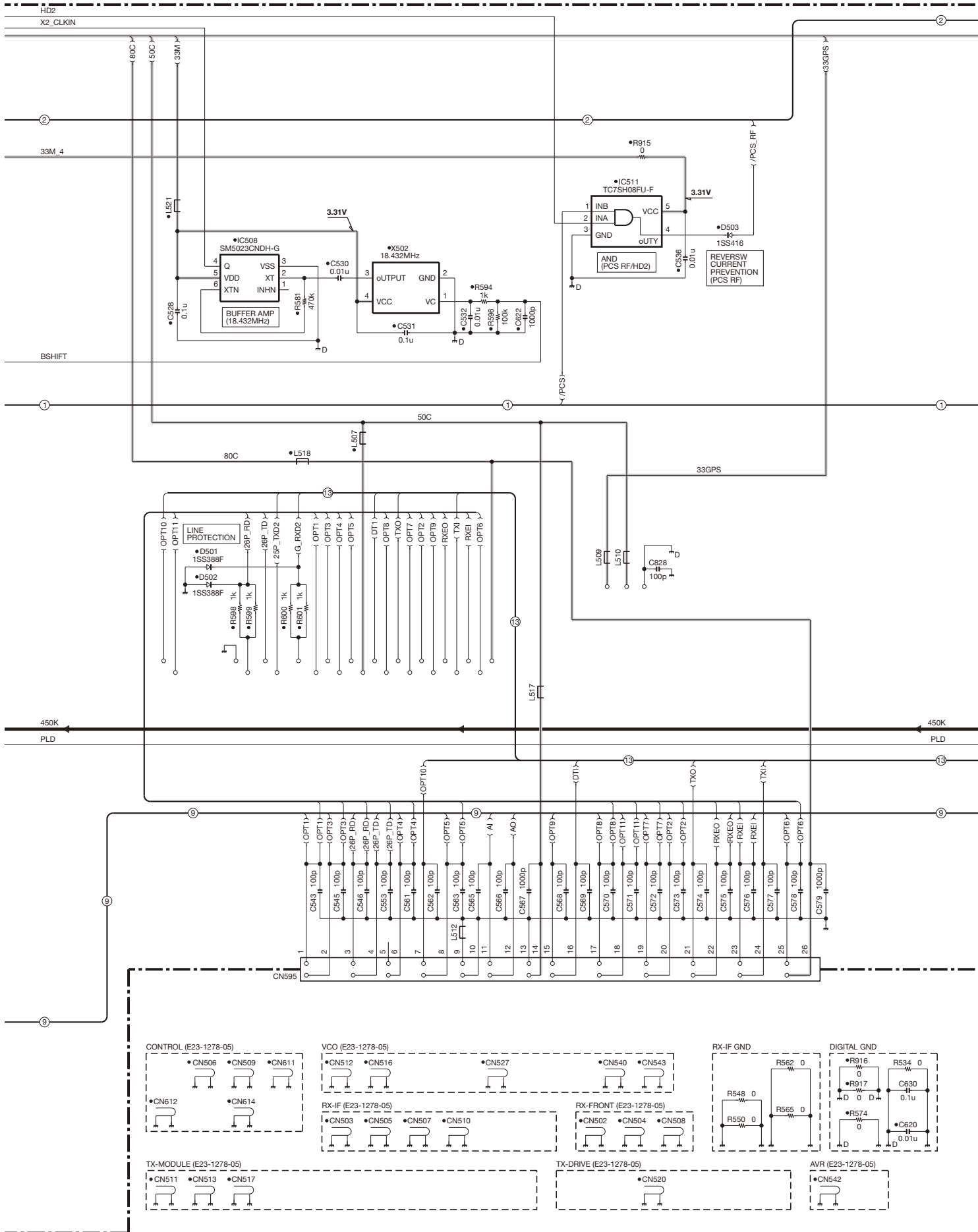

SCHEMATIC DIAGRAM NX-800H

TX-RX UNIT (X57-7750-18) (A/2)

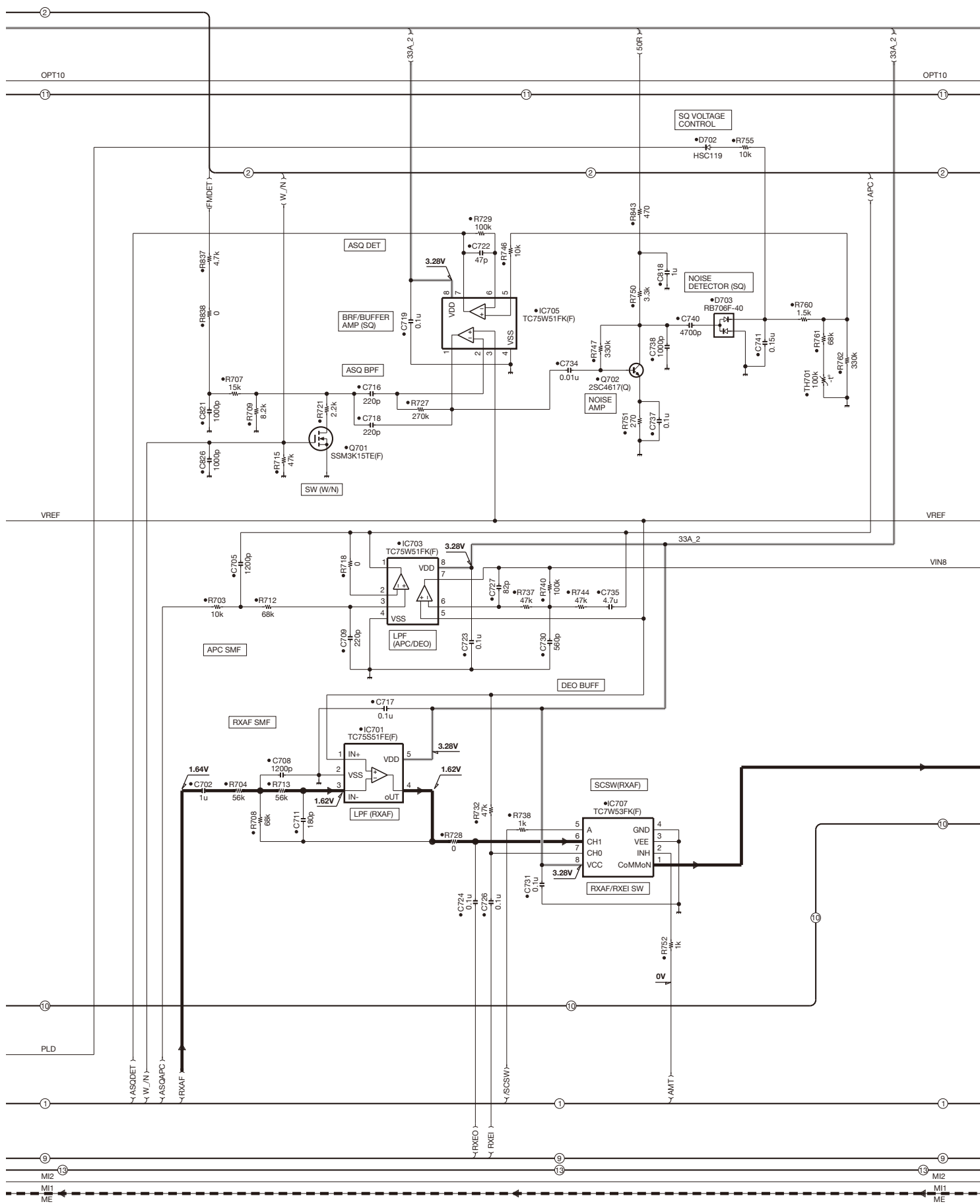

NX-800H SCHEMATIC DIAGRAM

TX-RX UNIT (X57-7750-18) (A/2)

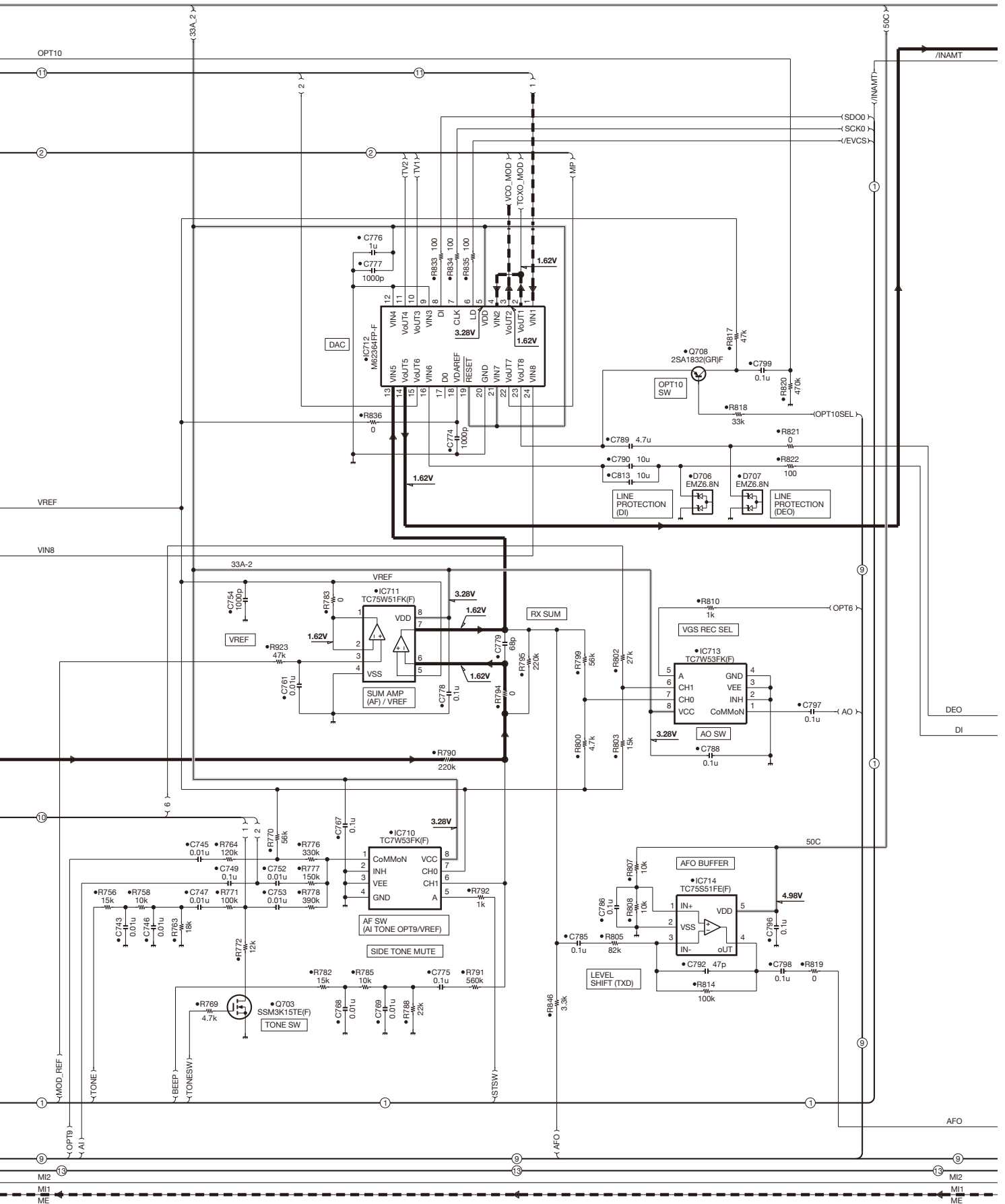

NX-800H SCHEMATIC DIAGRAM

TX-RX UNIT (X57-7750-18) (A/2)

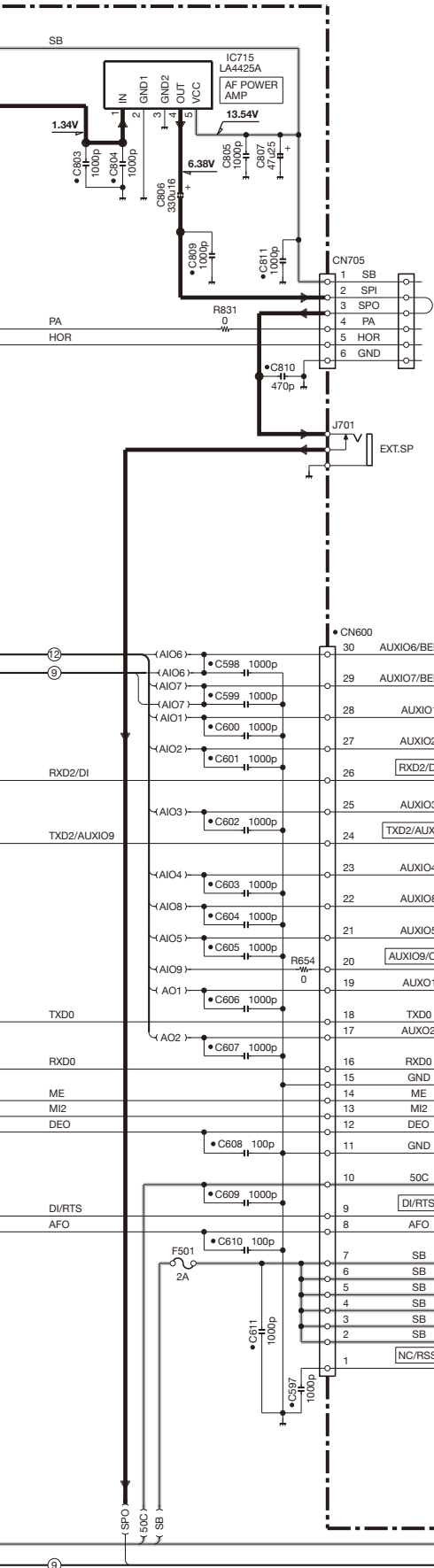

TX-RX UNIT (X57-7750-18) (B/2) : D-SUB25

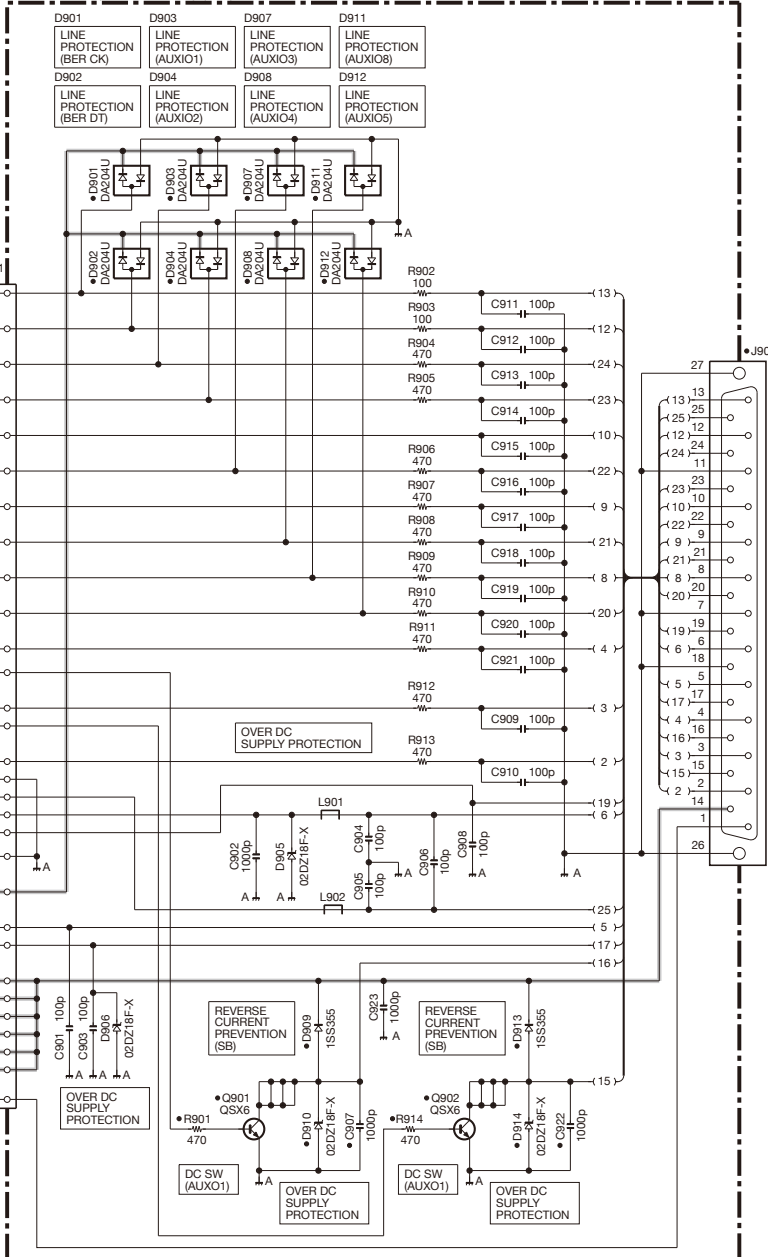

SCHEMATIC DIAGRAM NX-800H

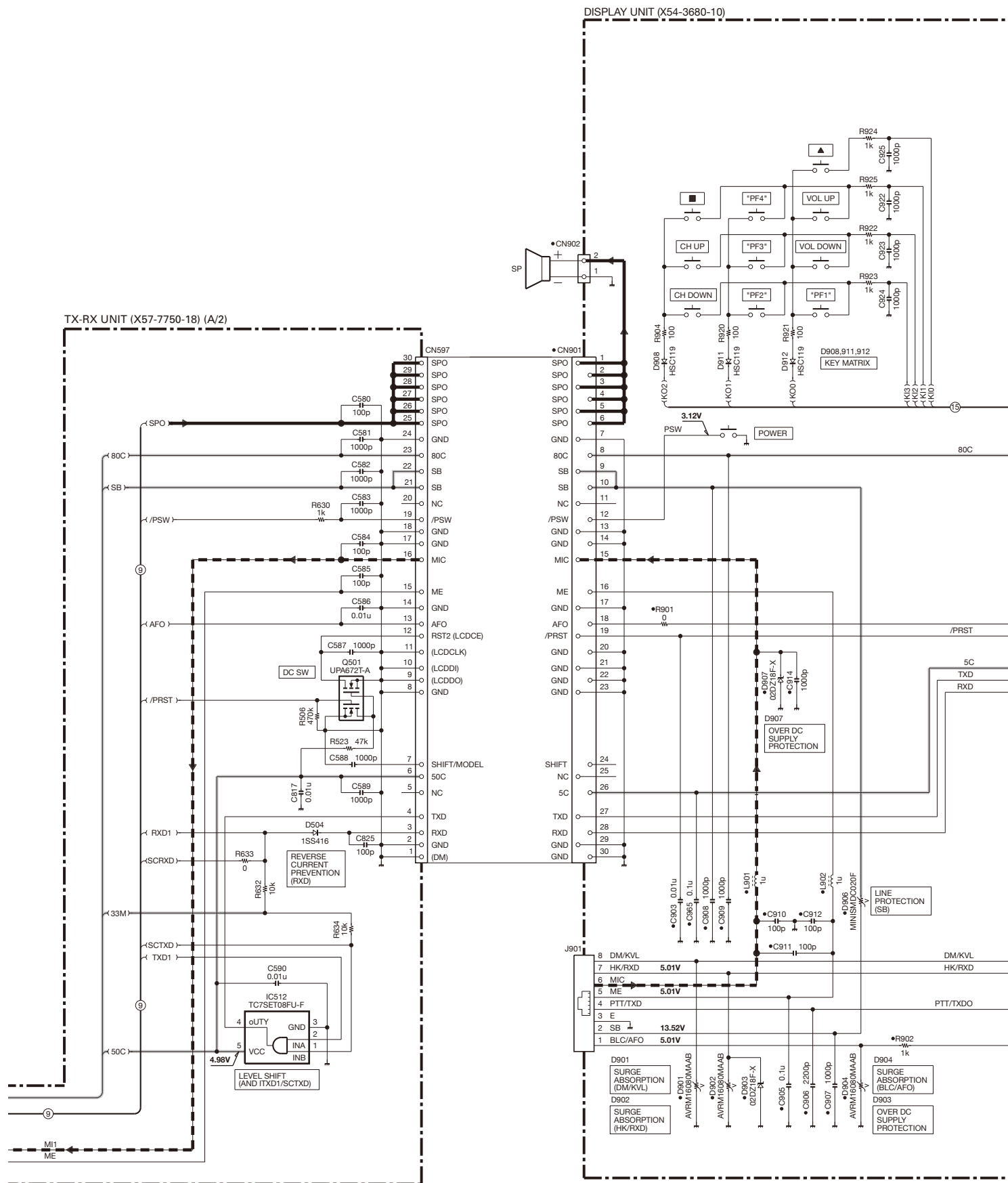

NX-800H SCHEMATIC DIAGRAM

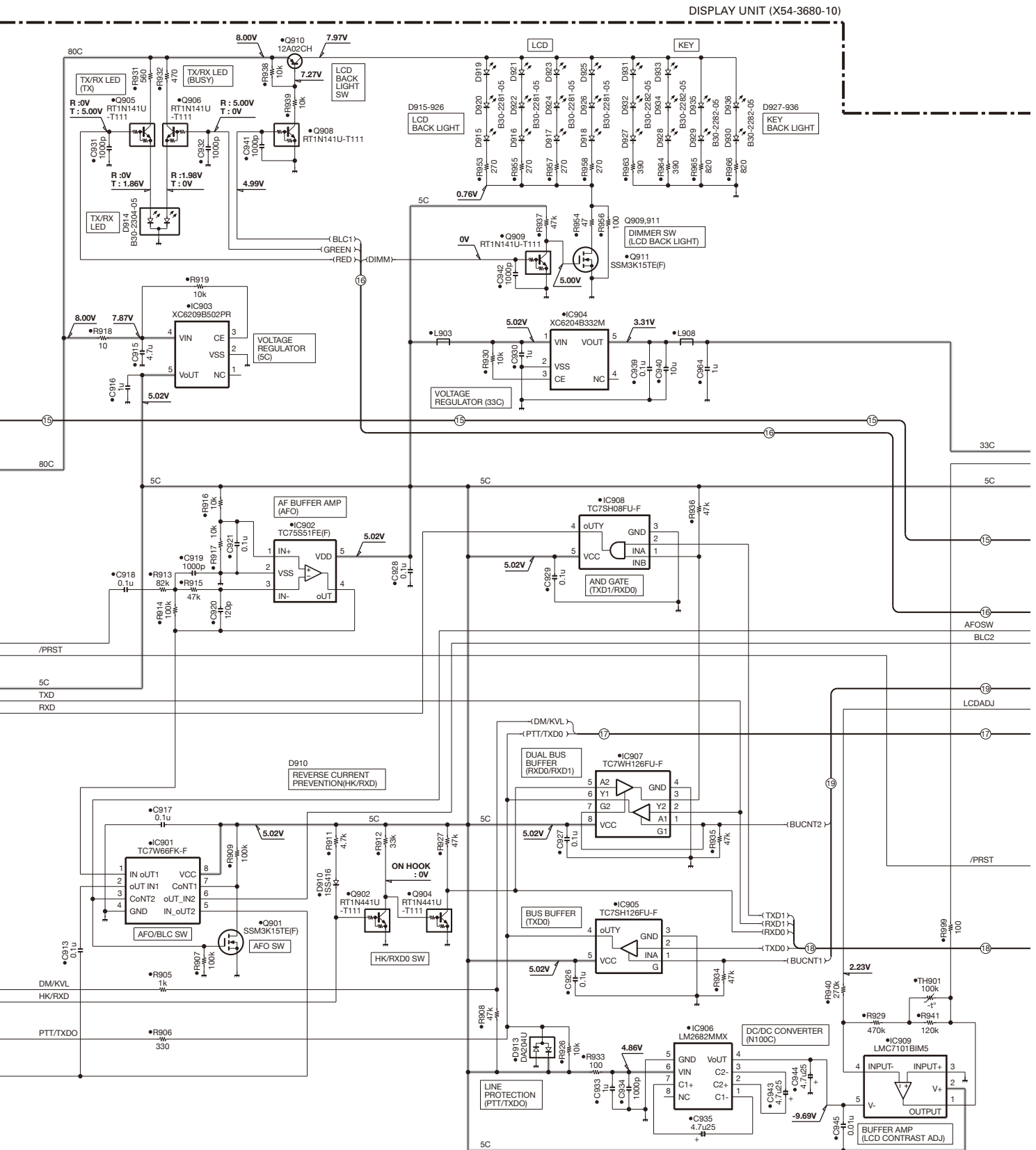

SCHEMATIC DIAGRAM NX-800H

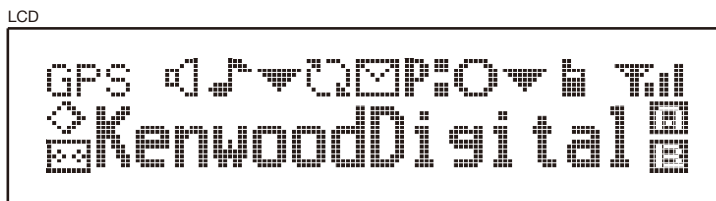

DISPLAY UNIT (X54-3680-10)

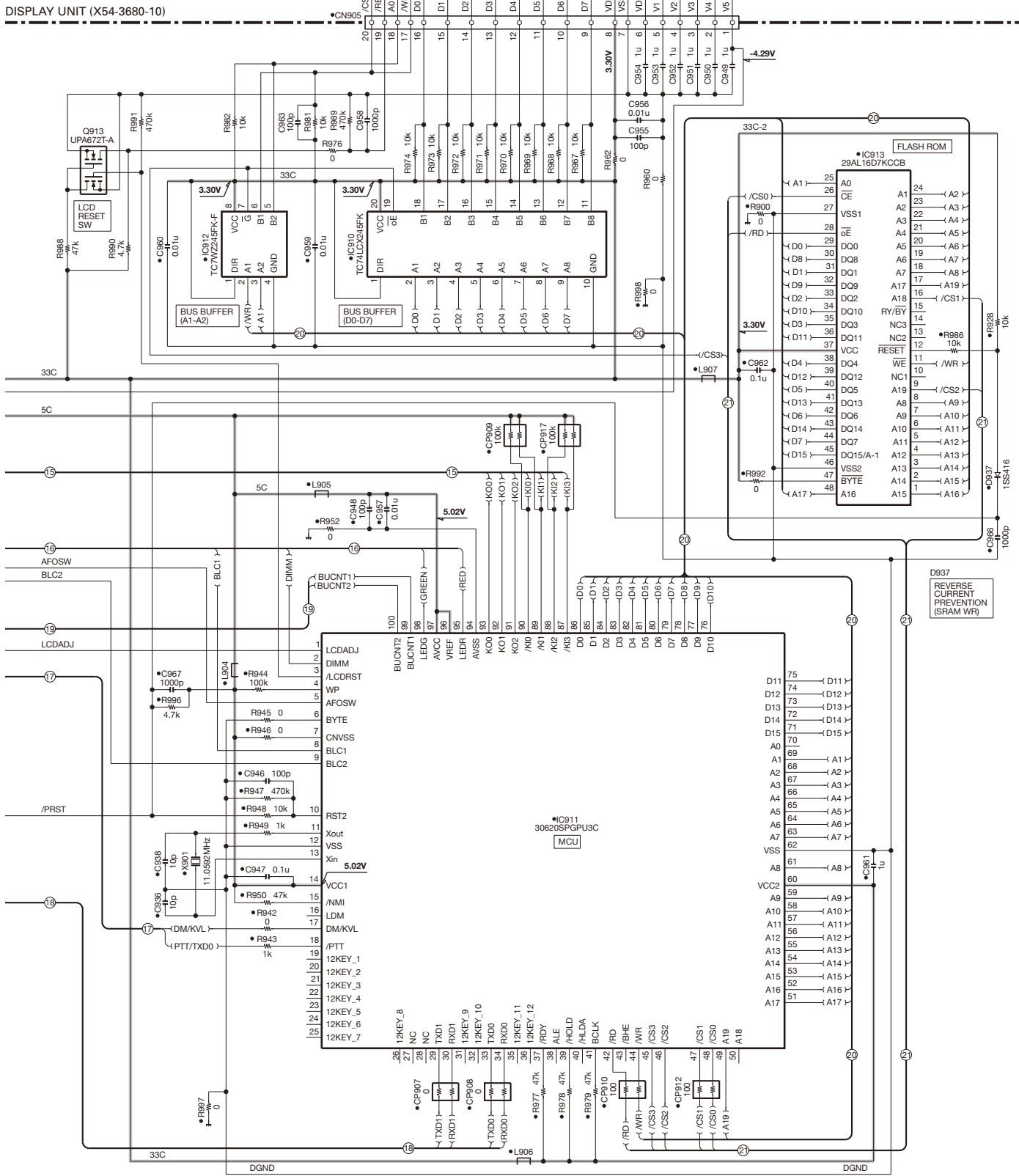

Note : The components marked with a dot (•) are parts of foil side.

NX-800H

LEVEL DIAGRAM

Receiver Section

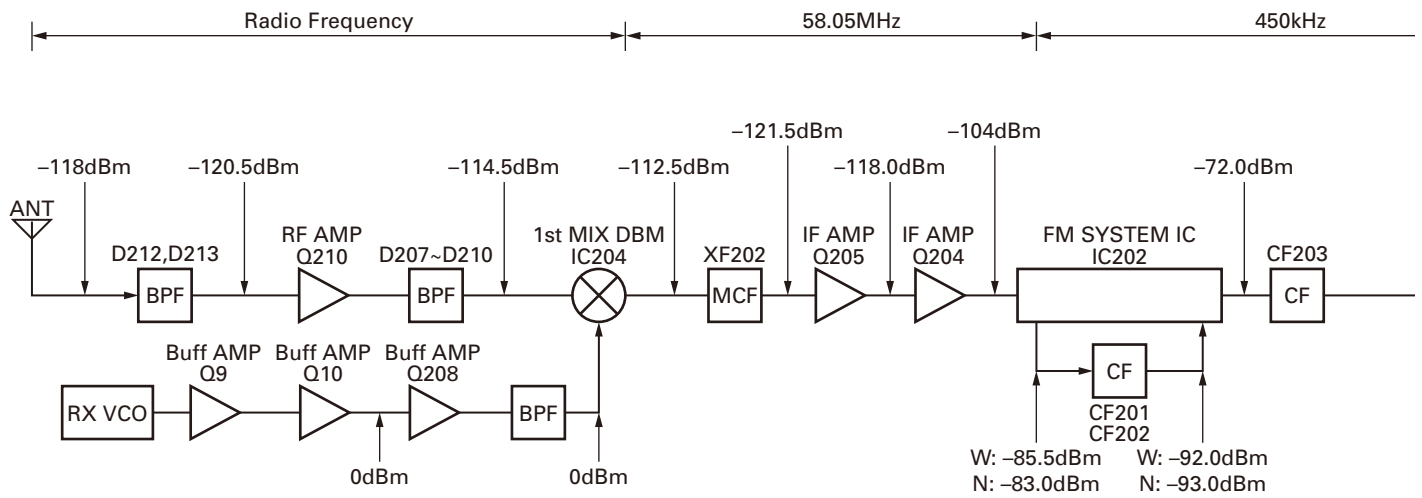

SG input level for 12dB SINAD are obtained Measured by connecting SG to each point via a 0.01 μ F capacitor.

Transmitter Section

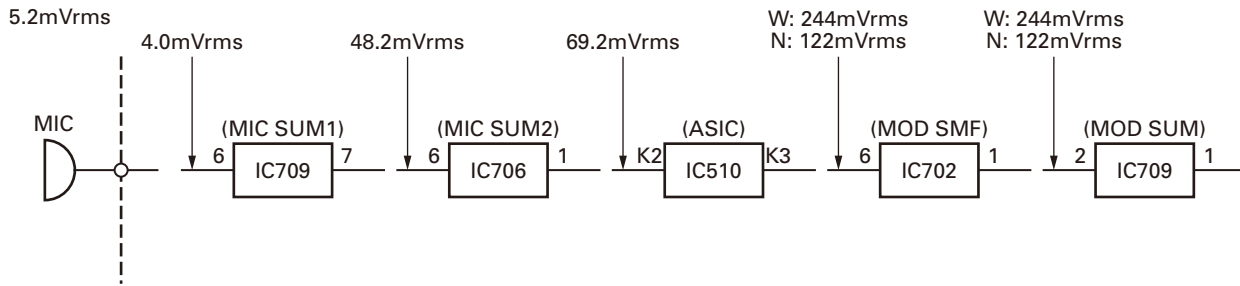

MIC input : 3kHz DEV. (Wide), 1.5kHz DEV. (Narrow) at 1kHz MOD.
Transmitting frequency : Center frequency

LEVEL DIAGRAM

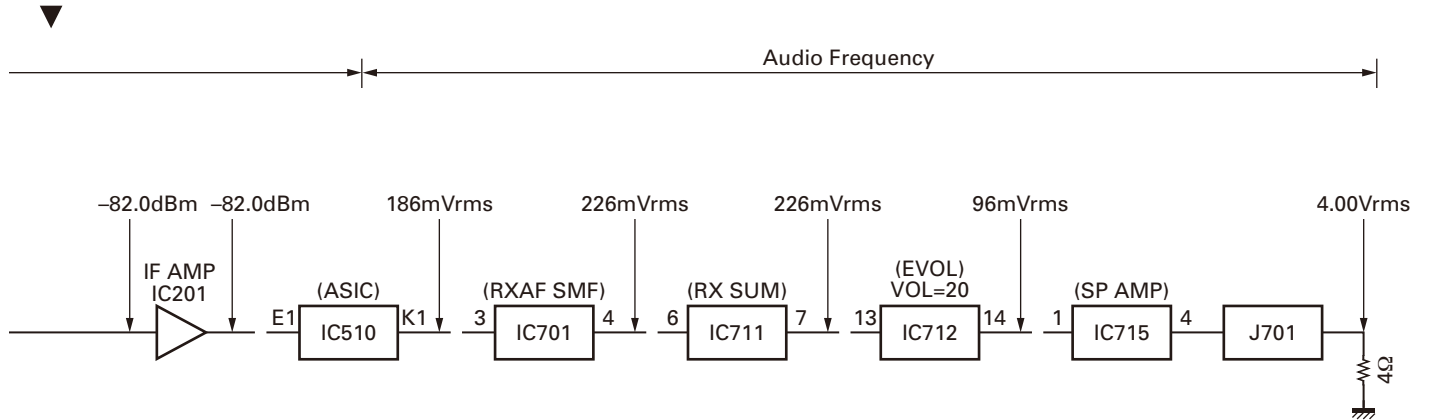

AF VTVM

AF level obtained when the AF output level is adjusted for 4.00V/4Ω with the front panel AF VOL control. Measured with AF voltmeter connected to the external speaker jack, receiving a -53dBm SSG signal modulated at 1kHz, DEV. WIDE 3kHz (NARROW 1.5kHz).

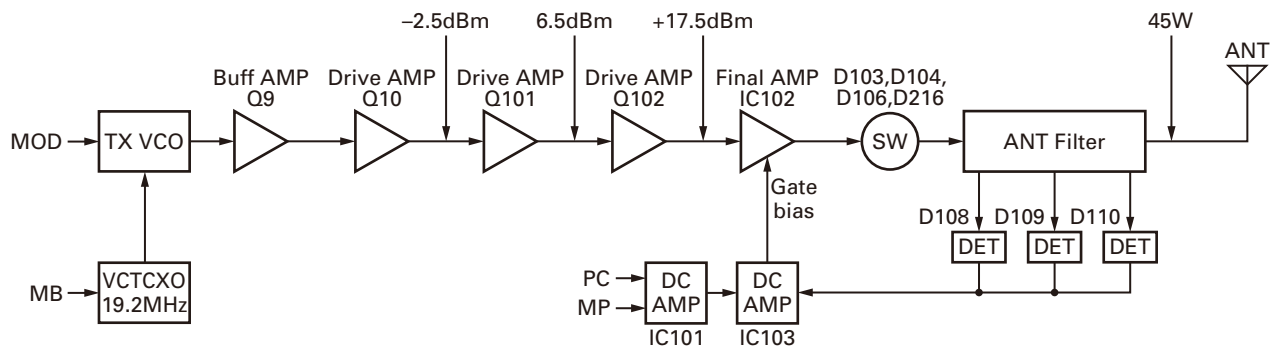
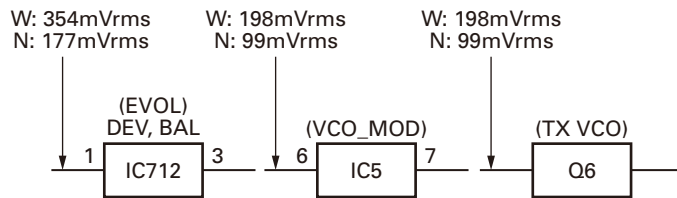

NX-800H BLOCK DIAGRAM

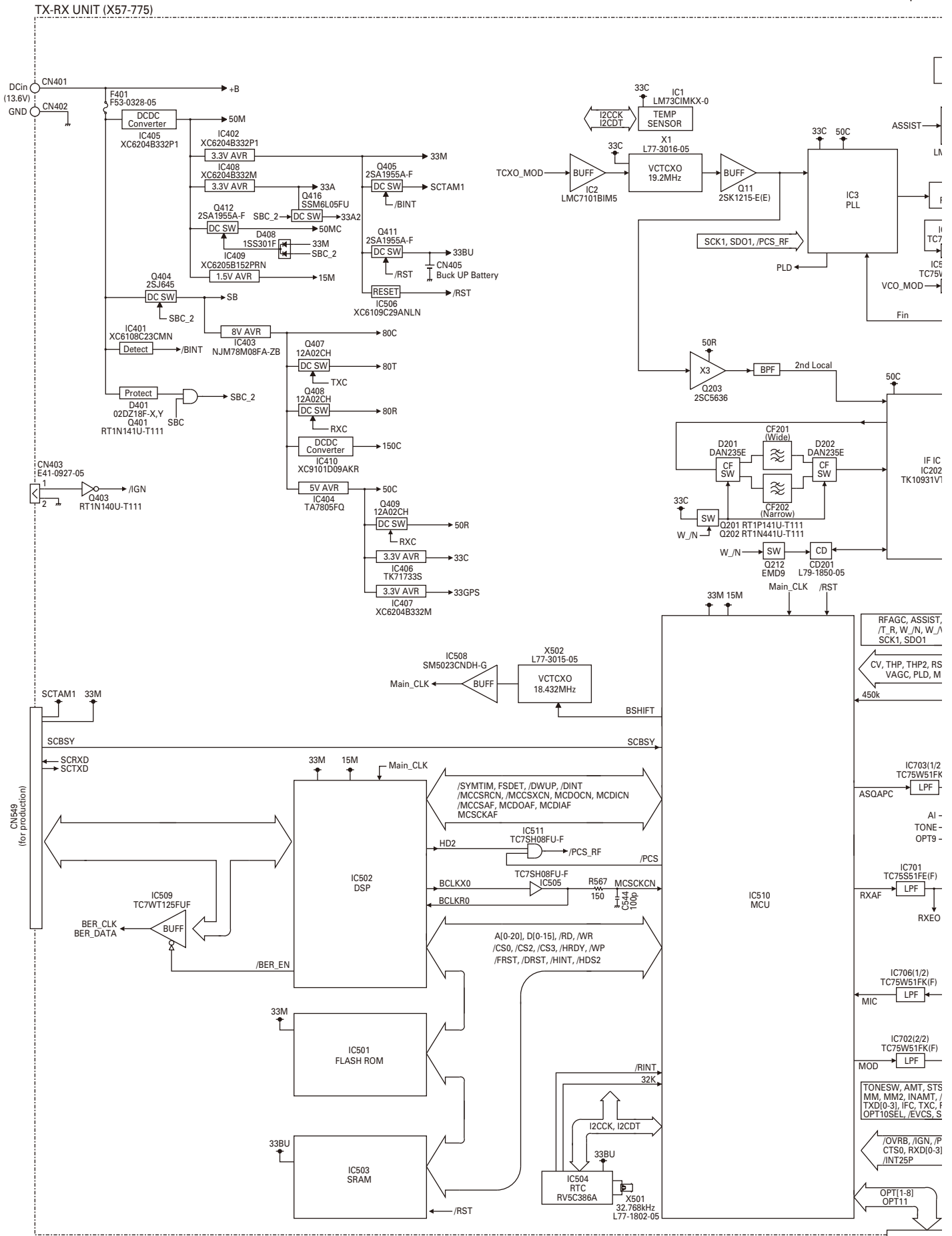

BLOCK DIAGRAM

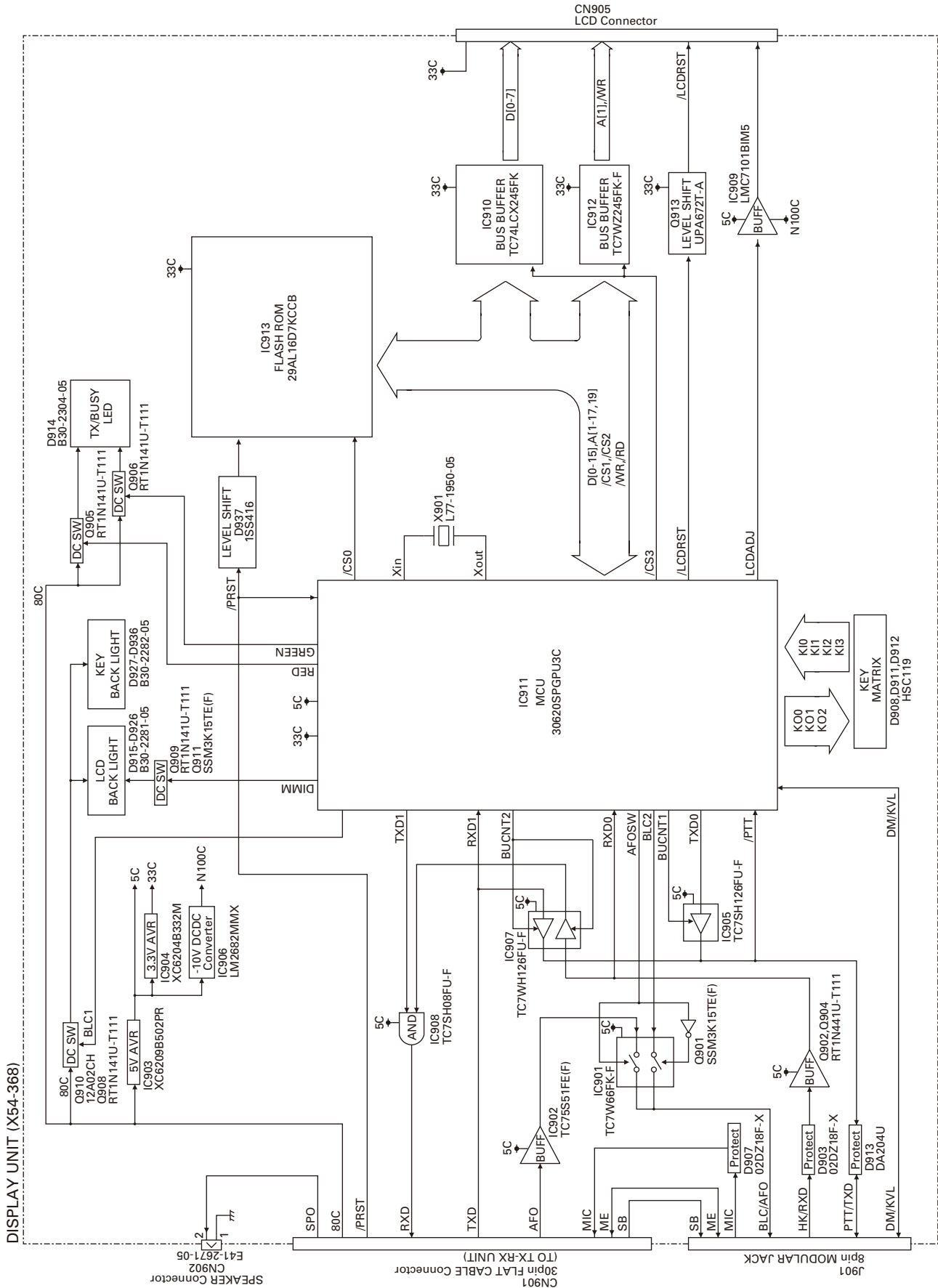

SPECIFICATIONS

GENERAL

Frequency Range.....	380~400MHz
Number of Channels.....	512
Zones.....	128
Max. Channels per Zone.....	250
Channel Spacing.....	Analog: 12.5/25 kHz Digital: 6.25/12.5 kHz
Operating Voltage.....	11.6~15.7V
Operating Temperature Range	-22°F~+140°F (-30°C~+60°C)
Frequency Stability	±1.0ppm
Antenna Impedance	50Ω
Dimensions (W x H x D)	6.30" x 1.77" x 618" in. (160 x 45 x 157 mm)
(Projections not included)	
Weight.....	3.03 lbs. (1.38 kg)

RECEIVER

Sensitivity	Digital @6.25kHz (3% BER): 0.20μV Digital @12.5kHz (3% BER): 0.28μV
	Analog 12dB SINAD: 0.25μV
Selectivity	Analog @25kHz: -80dB Analog @12.5kHz: -70dB
Intermodulation Distortion	Analog @25kHz: -75dB Analog @12.5kHz: -75dB
Spurious Response.....	Analog: -85dB
Audio Distortion.....	Less than 3%
Audio Output	4W/4Ω

TRANSMITTER

RF Power Output.....	10~45W
Spurious Response.....	75dB
FM Hum and Noise (Typ).....	Analog @25kHz: 50dB Analog @12.5kHz: 45dB
Modulation	16K0F3E, 14K4F1D, 11K0F3E, 8K30F1E, 8K30F1D, 8K30F7W, 4K00F1E, 4K00F1D, 4K00F7W, 4K00F2D

Analog measurements made per TIA/EIA 603 and specifications shown are typical.

KENWOOD reserves the right to change specifications without prior notice or obligation.

NX-800H

Kenwood Corporation

2967-3, Ishikawa-machi, Hachioji-shi, Tokyo, 192-8525 Japan

Kenwood U.S.A. Corporation

P.O. BOX 22745, 2201 East Dominguez Street, Long Beach,
CA 90801-5745, U.S.A.

Kenwood Electronics Canada Inc.

6070 Kestrel Road, Mississauga, Ontario, Canada L5T 1S8

Kenwood Electronics Deutschland GmbH

Rembrücker Str. 15, 63150 Heusenstamm, Germany

Kenwood Electronics Belgium N.V.

Leuvensesteenweg 248 J, 1800 Vilvoorde, Belgium

Kenwood Electronics France S.A.

L'Etoile Paris Nord 2, 50 Allée des Impressionnistes,
Bp 58416 Villepinte, 95944 Roissy Ch De Gaulle Cedex

Kenwood Electronics UK Limited

KENWOOD House, Dwight Road, Watford, Herts.,
WD18 9EB United Kingdom

Kenwood Electronics Europe B.V.

Amsterdamseweg 37, 1422 AC Uithoorn, The Netherlands

Kenwood Electronics Italia S.p.A.

Via G. Sirtori, 7/9 20129 Milano, Italy

Kenwood Ibérica, S.A.

Bolivia, 239-08020 Barcelona, Spain

Kenwood Electronics Australia Pty. Ltd.

Talavera Business Park Building A, 4 Talavera Road,
North Ryde NSW 2113 Australia

Kenwood Electronics (Hong Kong) Ltd.

Unit 3712-3724, Level 37, Tower one Metroplaza, 223 Hing Fong Road,
Kwai Fong, N.T., Hong Kong

Kenwood Electronics Singapore Pte Ltd

1 Ang Mo Kio Street 63, Singapore 569110



NX-800H PC BOARD

PC BOARD NX-800H

DISPLAY UNIT (X54-3680-10) Component side view (J79-0157-39)

DISPLAY UNIT (X54-3680-10) Component side view (J79-0157-39)

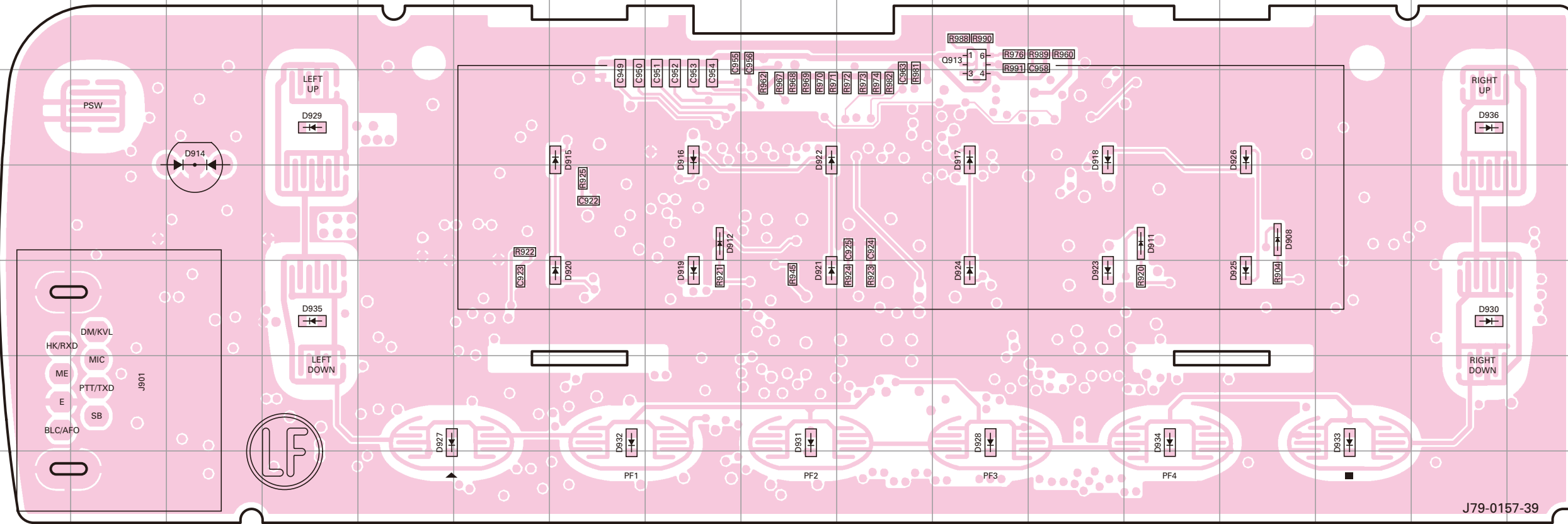

Ref. No.	Address	Ref. No.	Address
Q913	2K	D924	5K
D908	4N	D925	5N
D911	4M	D926	3M
D912	4H	D927	6E
D914	3C	D928	6K
D915	3G	D929	3D
D916	3H	D930	5P
D917	3K	D931	6I
D918	3L	D932	6G
D919	5H	D933	6O
D920	5G	D934	6M
D921	5I	D935	5D
D922	3I	D936	3P
D923	5L		

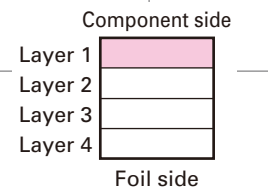

DISPLAY UNIT (X54-3680-10) Foil side view (J79-0157-39)

DISPLAY UNIT (X54-3680-10) Foil side view (J79-0157-39)

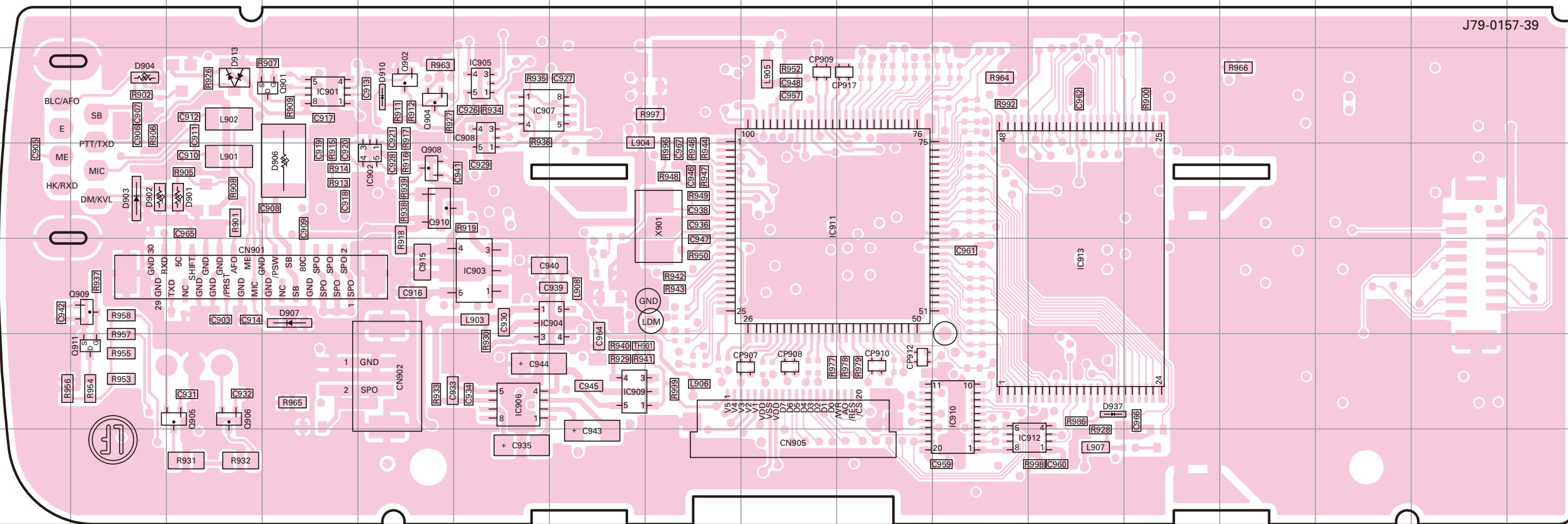

Ref. No.	Address	Ref. No.	Address
IC901	9D	Q905	12C
IC902	10E	Q906	12C
IC903	11F	Q908	10E
IC904	11G	Q909	11B
IC905	9F	Q910	10E
IC906	12F	Q911	12B
IC907	9F	D901	10C
IC908	9F	D902	10B
IC909	12G	D903	10B
IC910	12K	D904	9B
IC911	10I	D906	10D
IC912	13L	D907	11D
IC913	11L	D910	9E
Q901	9D	D913	9C
Q902	9E	D937	12L
Q904	9E		

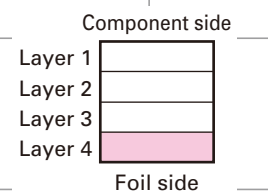

NX-800H PC BOARD

TX-RX UNIT (X57-7750-18) (A/2)
Component side view (J79-0208-19 A/2)

PC BOARD NX-800H

TX-RX UNIT (X57-7750-18) (A/2)
Component side view (J79-0208-19 A/2)

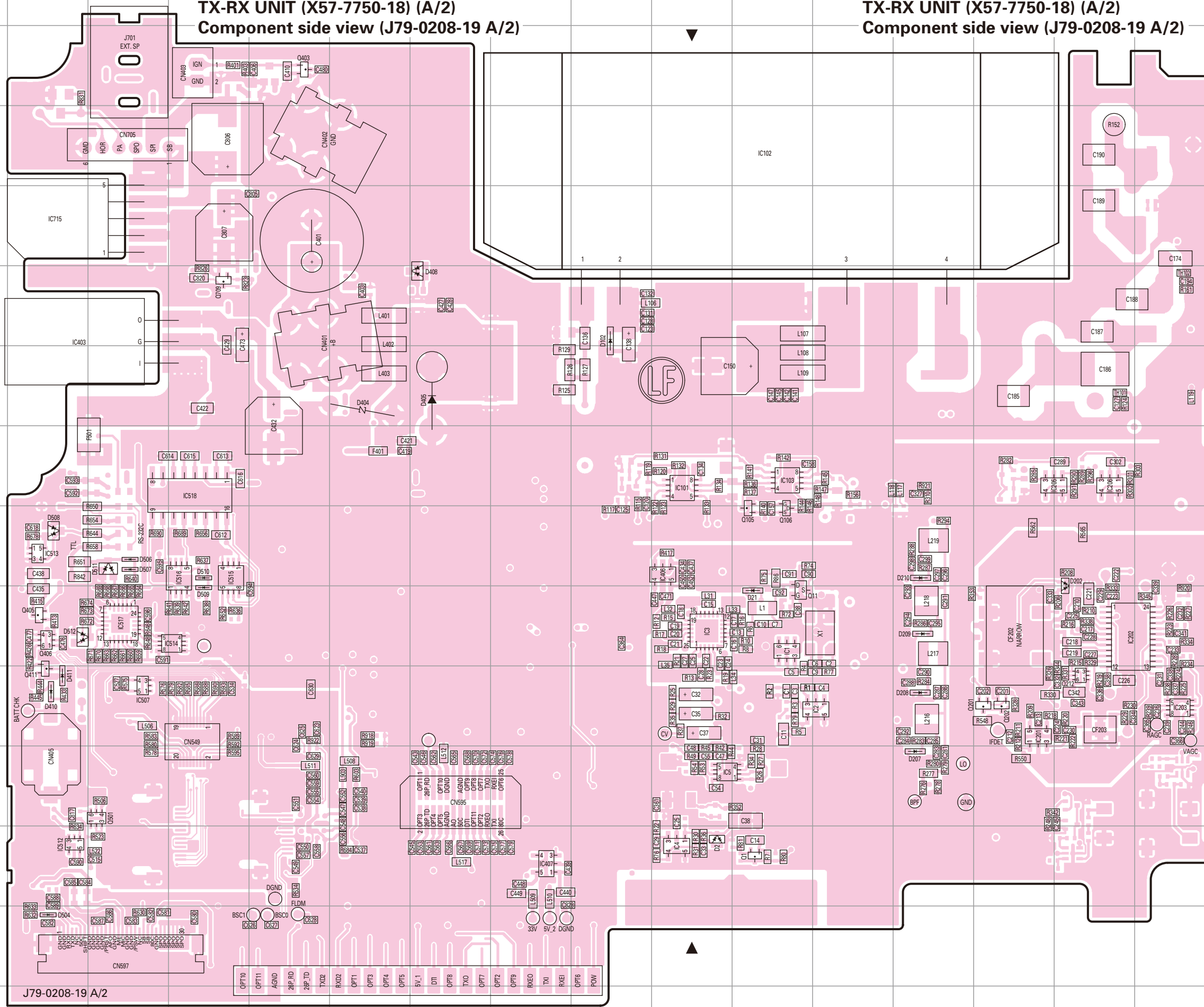

Ref. No.	Address	Ref. No.	Address
IC1	9K	Q202	10N
IC2	10L	Q212	10O
IC3	9J	Q403	2E
IC4	12J	Q405	9B
IC5	11J	Q406	9B
IC101	7J	Q411	10B
IC102	3K	Q501	11C
IC103	7K	Q709	5D
IC201	10N	D2	12J
IC202	9O	D21	9K
IC203	10P	D102	5I
IC205	7N	D202	8O
IC206	7O	D207	11M
IC403	5B	D208	10M
IC406	8J	D209	9M
IC407	12H	D210	8M
IC507	10C	D404	6F
IC512	12B	D405	6G
IC513	8B	D408	5G
IC514	9D	D410	10B
IC515	8D	D411	10B
IC516	8D	D504	13B
IC517	9C	D506	8C
IC518	7D	D507	8C
IC715	4B	D508	8B
Q1	12K	D509	9D
Q11	9K	D510	8D
Q105	8K	D511	8C
Q106	8K	D512	9B
Q201	10N		

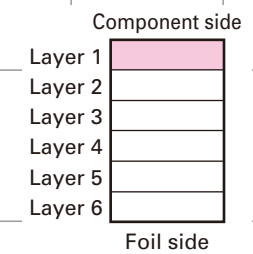

J79-0208-19 A/2

- OPT10
- OPT11
- AGND
- 2P_RD
- 2P_TD
- TX02
- RX02
- OPT1
- OPT3
- OPT4
- OPT5
- BV_1
- DI1
- OPT8
- TX0
- OPT7
- OPT2
- OPT9
- RXEO
- TXI
- RXEI
- OPT6
- POW

NX-800H PC BOARD

TX-RX UNIT (X57-7750-18) (A/2)
Foil side view (J79-0208-19 A/2)

PC BOARD NX-800H

TX-RX UNIT (X57-7750-18) (A/2)
Foil side view (J79-0208-19 A/2)

Ref. No.	Address	Ref. No.	Address	Ref. No.	Address
IC204	11F	Q6	10J	D4	11J
IC401	7M	Q7	10K	D7	11H
IC402	6N	Q8	10J	D8	11J
IC404	6P	Q9	10I	D9	11H
IC405	5N	Q10	10I	D10	11I
IC408	5M	Q101	7I	D11	11J
IC409	7N	Q102	7J	D12	11I
IC410	12J	Q203	8E	D14	11J
IC501	12P	Q204	9D	D101	9H
IC502	10Q	Q205	10D	D103	5F
IC503	12Q	Q208	10G	D104	6F
IC504	10N	Q210	7G	D106	6E
IC505	10P	Q401	3P	D108	6D
IC506	13P	Q402	4P	D109	5D
IC508	10O	Q404	4P	D110	4D
IC509	9P	Q407	5P	D201	10E
IC510	12O	Q408	5P	D205	9H
IC511	9O	Q409	7O	D212	7E
IC701	12M	Q410	7N	D213	7E
IC702	8N	Q412	6N	D216	7D
IC703	12L	Q413	5P	D401	3O
IC704	10M	Q414	5P	D403	4P
IC705	12L	Q415	7O	D406	3P
IC706	8M	Q416	5N	D407	4N
IC707	12M	Q417	12I	D409	4N
IC708	8N	Q701	12K	D412	5N
IC709	8O	Q702	11L	D501	13O
IC710	11M	Q703	12M	D502	13O
IC711	11L	Q704	7P	D503	9O
IC712	9L	Q705	8P	D702	11L
IC713	11K	Q706	8R	D703	11L
IC714	11L	Q707	8R	D704	7O
Q3	9I	Q708	10L	D705	8O
Q4	9J	Q710	5Q	D706	9L
Q5	10I	D3	11I	D707	9M

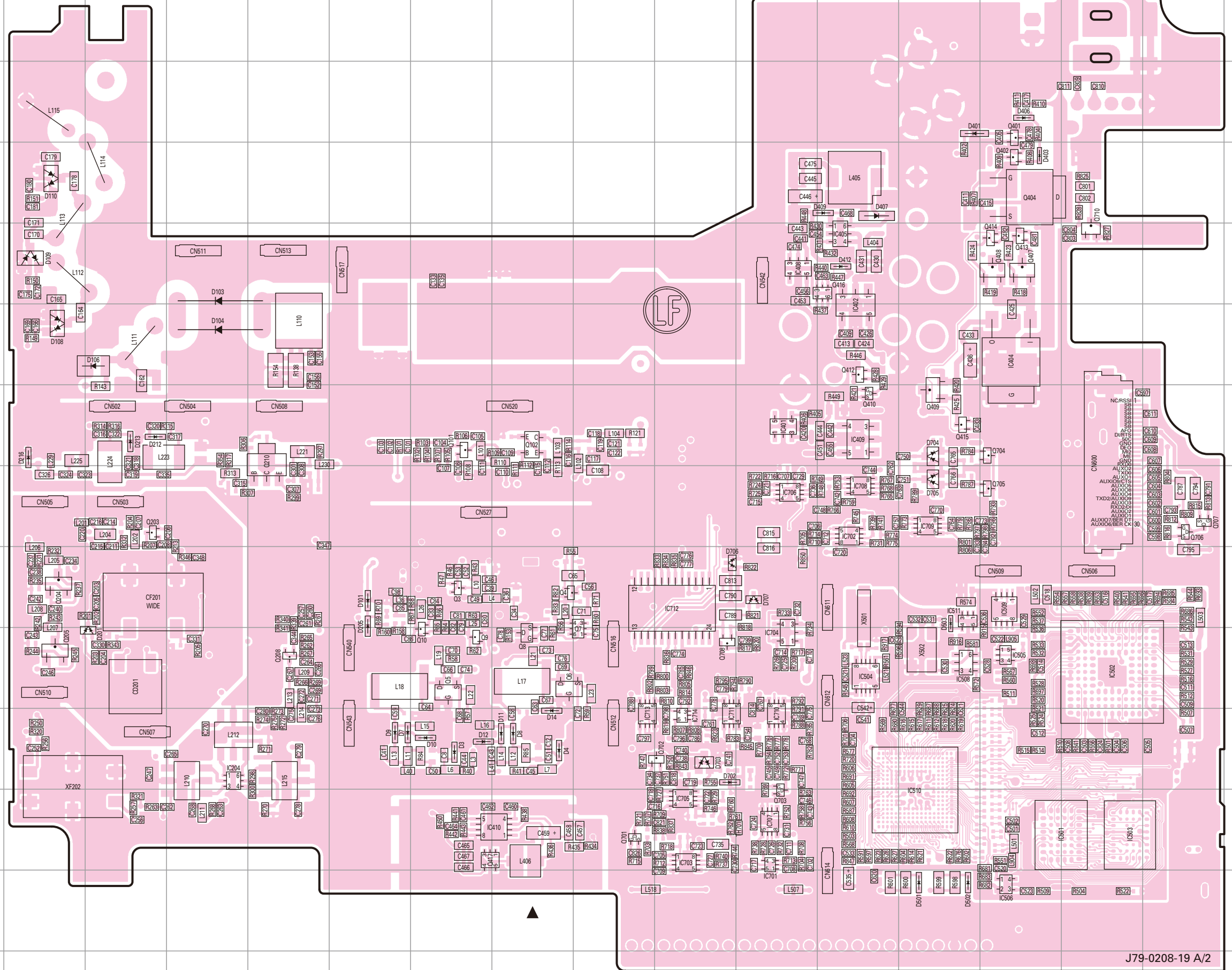
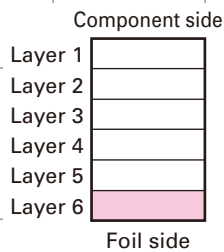

NX-800H PC BOARD

TX-RX UNIT (X57-7750-18) (B/2) Component side view (J79-0208-19 B/2)

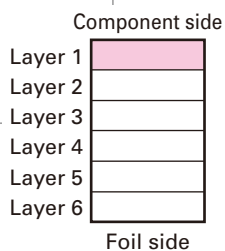
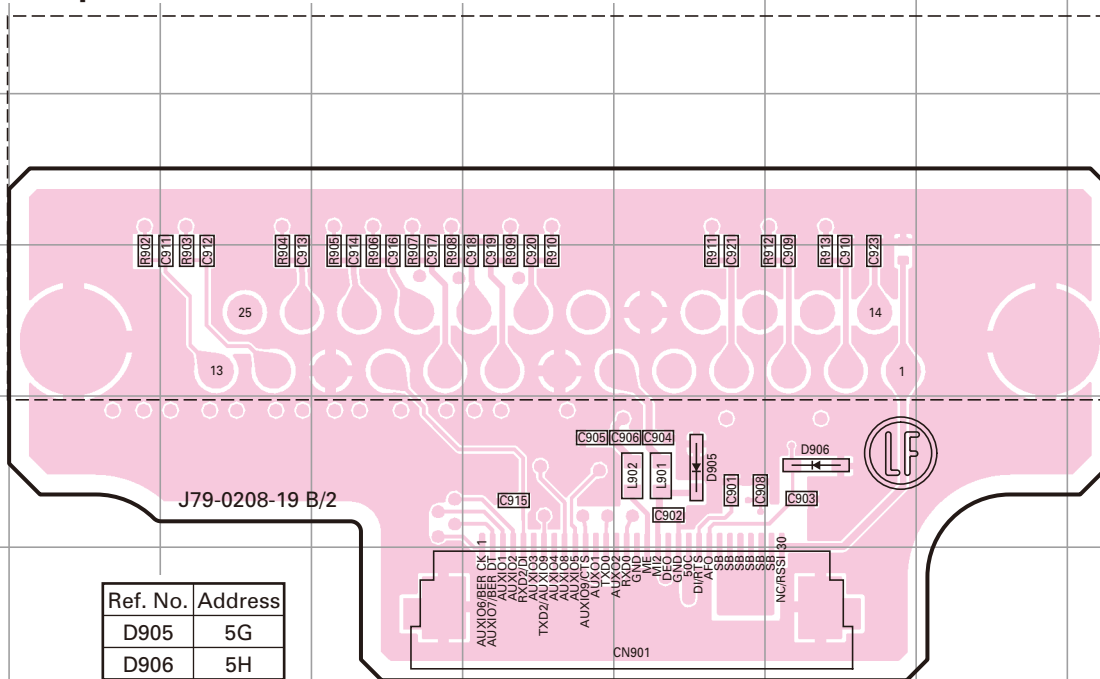

Ref. No.	Address
D905	5G
D906	5H

TX-RX UNIT (X57-7750-18) (B/2) Foil side view (J79-0208-19 B/2)

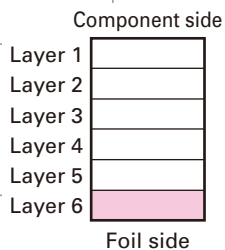
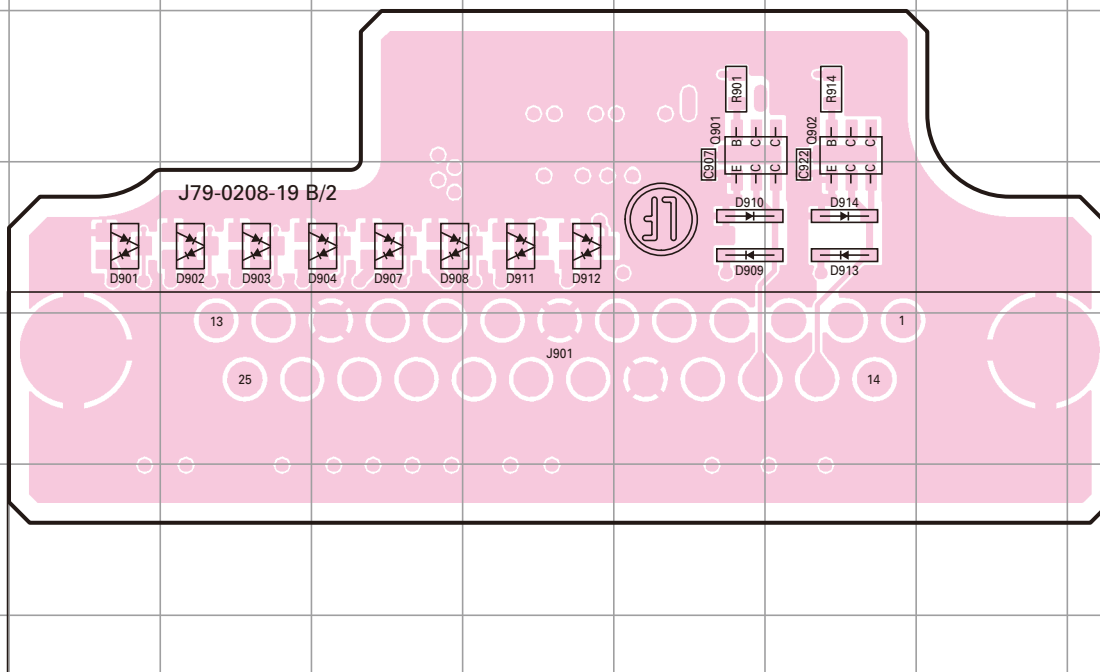

Ref. No.	Address	Ref. No.	Address	Ref. No.	Address
Q901	8G	D904	9E	D911	9F
Q902	8H	D907	9E	D912	9F
D901	9C	D908	9E	D913	9H
D902	9D	D909	9G	D914	9H
D903	9D	D910	9G		



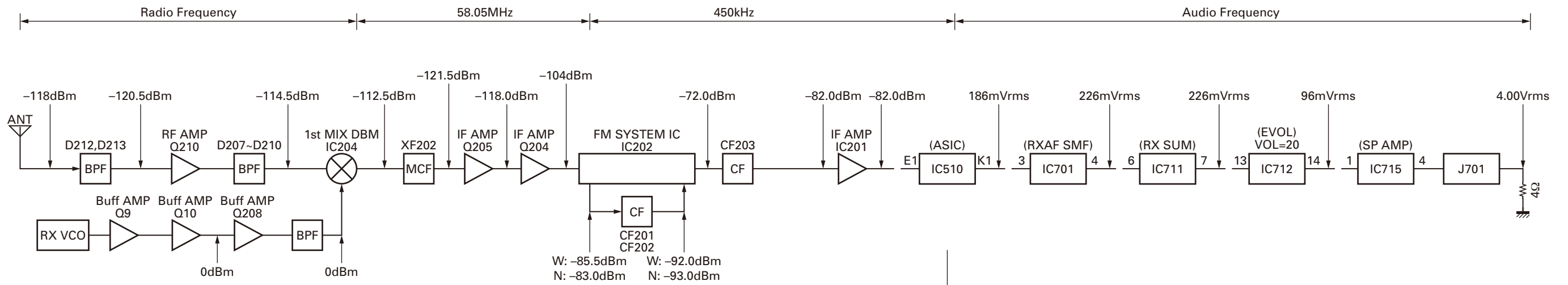

SG input level for 12dB SINAD are obtained Measured by connecting SG to each point via a 0.01μF capacitor.

AF VTVM

AF level obtained when the AF output level is adjusted for 4.00V/4Ω with the front panel AF VOL control. Measured with AF voltmeter connected to the external speaker jack, receiving a -53dBm SSG signal modulated at 1kHz, DEV. WIDE 3kHz (NARROW 1.5kHz).

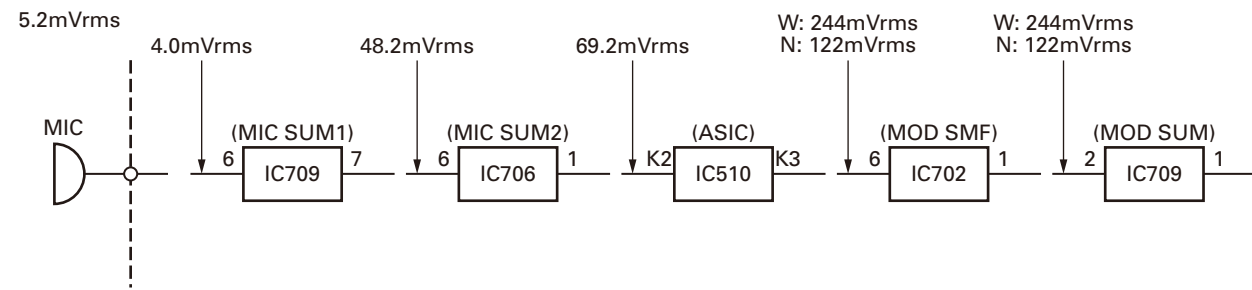

MIC input : 3kHz DEV. (Wide), 1.5kHz DEV. (Narrow) at 1kHz MOD.
Transmitting frequency : Center frequency

