

# KINNEY® KLRC™ SERIES

## Liquid Ring Vacuum Pumps

### Models

KLRC-40	KLRC-75	KLRC-100	KLRC-125	KLRC-200
KLRC-300	KLRC-525	KLRC-526	KLRC-950	KLRC-951

# INSTALLATION OPERATION MAINTENANCE REPAIR MANUAL



### WARNING

DO NOT OPERATE  
BEFORE READING MANUAL



4840 West Kearney Street, P. O. Box 2877  
Springfield, Missouri USA 65801-2877  
Tel 417 865-8715 800 825-6937 Fax 417 865-2950  
[www.tuthillvacuumblower.com](http://www.tuthillvacuumblower.com)

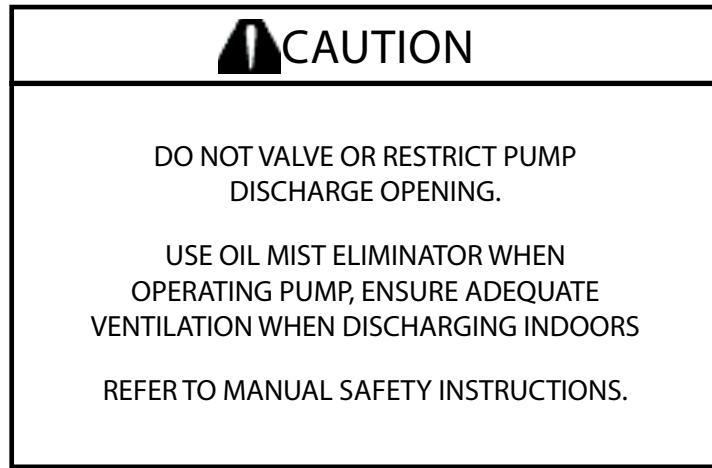

### NOTICE

The above safety instruction tags were permanently affixed to your pump prior to shipment.  
Do not remove, paint over or obscure in any manner.

Failure to heed these warnings could result in serious bodily injury  
to the personnel operating and maintaining this equipment.

---

## SAFETY PRECAUTIONS FOR LIQUID RING PUMPS

Please read the following safety information on this page before operating your vacuum pump.

- Please read the following safety information on this page before operating your vacuum pump.
- Do not operate the pump without the coupling or belt guard properly attached. Disconnect the pump motor from the electrical supply at the main disconnect before removing the coupling or belt guard . Replace the coupling or belt guard before reconnecting the power supply to the pump motor. Operating the pump without the coupling or belt guard properly installed exposes personnel in the vicinity of the pump to risk from rotating drive components.
- CAUTION: Do not operate the pump with oxygen-enriched gas in the suction line, unless the pump has been properly cleaned, inspected and certified to be free of hydrocarbon presence and prepared with an inert fluid suitable for the application.
- Oxygen-enriched gas is defined as gas of which the constituents include by volume (mol. %) an amount of oxygen greater than that of standard atmospheric air (typically 20-21% by volume).
- If the oxygen content in the gas stream exceeds the proportions found in standard atmospheric air, then it is considered an oxygen-enriched gas and standard mineral oil, synthetic hydrocarbon oil or other non-inert fluids should not be used.
- WARNING: Pumping oxygen-enriched gases with mineral oil, synthetic hydrocarbon oil or other non-inert fluids can cause fire or explosion in the pump, resulting in damage or serious bodily injury or death.
- Take precautions to avoid prolonged or excessive exposure to oil mist or process materials emanating from the discharge of the pump.
- Do not allow the pump to discharge into a closed, or inadequately ventilated room. Laws and ordinances may pertain to your local area regarding discharge of vapor to atmosphere. Check local laws and ordinances prior to operation of the pump with discharge to outside atmosphere. Venting of the discharge of an oil mist eliminator to outside atmosphere is highly recommended.
- Do not restrict the pump discharge in any way, or place valves in the discharge line. The vacuum pump is a compressor and will generate high pressures without stalling the motor when operated at low suction pressures. Excessive pressure could cause pump damage or serious bodily injury.
- Disconnect the pump motor from the electrical supply at the main disconnect before disassembling or servicing the pump. Make sure pump is completely reassembled, the coupling or belt guard is properly installed, and that all fill and drain valves are installed and closed before reconnecting the power supply. Accidental starting or operation of the pump while maintenance is in progress could cause pump damage or serious bodily injury.
- Lift pump only by strapping the crossover pipe. DO NOT lift equipment attached to pump by the pump lifting lugs.
- Do not touch hot surfaces on the pump. In normal operation at low pressures, surface temperatures will not normally exceed 180° F (82° C). Prolonged operation at 200 Torr (267 mbar a) may cause surface temperatures as high as 220° F (104° C)

## TABLE OF CONTENTS

SECTION	PAGE
INTRODUCTION	4
MODELS COVERED BY THIS MANUAL	4
NAMEPLATE DATA	4
SUITABLE APPLICATIONS	4
AVOID DAMAGE TO THE PUMP	4
SPECIFICATION TABLE (TABLE 1)	5
THEORY OF OPERATION	5
PROPERTIES OF SEALANTS	5
SEALANT TEMPERATURE	6
INSTALLATION	6
GENERAL	6
DIRECT COUPLED DRIVE	6
V-BELT DRIVE	6
SEALANT RECOVERY SYSTEMS	7
ONCE-THROUGH RECOVERY	7
PARTIAL SEALANT RECOVERY (PSR)	8
SEALANT PIPING	10
SEALANT FLOW CONTROL	10
COOLING PIPING FOR MECHANICAL SEALS	10
MANIFOLD PIPING	11
ELECTRICAL CONNECTIONS	11
SYSTEM COMPONENTS	11
INLET AIR EJECTORS	12
OPERATION	12
STARTING THE PUMP	12
PRESTART CHECKS	13
INITIAL START UP	13
PROCEDURE FOR MINIMUM SEALANT FLOW RATE	13
STOPPING THE PUMP	14
MAINTENANCE	14
GENERAL	14
SHAFT BEARINGS	14
SCALE OR RUST ACCUMULATION	15
MECHANICAL SHAFT SEALS	15
PREPARATION FOR STORAGE	15
SPARE PARTS	15
DISASSEMBLY	15
GENERAL	15
DISASSEMBLY PROCEDURE	15
REASSEMBLY	16
GENERAL	16
REASSEMBLY PROCEDURE	17
ASSEMBLY DRAWINGS & PARTS LISTS	23-31
WARRANTY – VACUUM PRODUCTS	32

## INTRODUCTION

CONGRATULATIONS on your purchase of a new KINNEY® KLRC™ Liquid Ring Vacuum Pump from Tuthill Vacuum & Blower Systems. Please examine the pump for shipping damage, and if any damage is found, report it immediately to the carrier. If the pump is to be installed at a later date make sure it is stored in a clean, dry location and rotated regularly. Make sure covers are kept on all openings. If the pump is stored outdoors be sure to protect it from weather and corrosion.

KINNEY KLRC vacuum pumps are built to exacting standards and if properly installed and maintained will provide many years of reliable service. We urge you to take time to read and follow every step of these instructions when installing and maintaining your pump. We have tried to make these instructions as straightforward as possible. We realize getting any new piece of equipment up and running in as little time as possible is imperative to production.

**WARNING:** Serious injury can result from operating or repairing this machine without first reading the service manual and taking adequate safety precautions.

**IMPORTANT:** Record the pump model and serial numbers in the OPERATING DATA form on the last page of this manual. You will save time and expense by including this reference identification on any replacement part orders, or if you require service or application assistance.

## MODELS COVERED BY THIS MANUAL

This manual contains installation, operation, and maintenance procedures for KLRC-40K to KLRC-951K. The nameplate on the pumps provides a letter coding for pump material and shaft seal type in the suffix following the KLRC model number.

## NAMEPLATE DATA

The first letter designates the standard materials of construction:

- B Cast Iron casing, bronze impellers, 316 stainless steel shaft and steel trim
- F Cast iron casing with stainless steel 316L impellers and 316 Shaft and steel trim
- C All stainless steel 316L pump, except for the outboard ball bearings, bearing end caps, and steel trim

The second suffix letter designates the standard type of shaft seal:

- A John Crane Type 21 seal — Carbon/Ceramic/Viton
- D Flow Serve RO Dura Seal — Carbon/Durchrome/Viton
- L PTFE encapsulated Viton O-Rings
- DD Flow Serve Double RO Dura Seal

Consult factory for alternate seal configurations. When the nameplate model designation is followed by the letters -HT the pump has an operating temperature limit of 220°F. Inquiries should be referred to Tuthill Vacuum & Blower Systems, referencing model and serial number of the pump.

## SUITABLE APPLICATIONS

Kinney Liquid Ring Vacuum Pumps (KLRC) are reliable non-pulsating pumps. KLRC pumps are two stage configuration, suitable for operation down to 30 Torr absolute (approximately 29 inches Hg. vacuum reference 30 inch barometer), when sealed with 60°F water.

Standard pumps with stainless steel impellers (designated with material codes F or C) are suitable for operation with sealant temperatures up to 160° F. Bronze impeller pumps (designated with material code B) and pumps with HT following the Model designation on the nameplate are suitable for operation with sealant temperatures up to 220°F. Consult Tuthill Vacuum & Blower Systems for applications requiring operations above 220°F.

## AVOID DAMAGE TO THE PUMP

- Unpack the pump carefully and handle only by methods that will not damage or misalign the pump.
- Do not run the pump dry. Make sure sealant is piped to both seals; see Figures 2 through 5.
- Do not allow sealant in the pump to freeze.
- Do not place any valves or restrictions in the discharge line.
- If the pump and motor are mounted on a base, the unit should only be lifted from the base or by attaching to the base. Lifting the unit by attaching to the pump or motor could disturb the alignment. The crossover manifolding on the KLRC-series pumps should never be used as an attaching area for lifting.

## SPECIFICATION TABLE (TABLE 1)

	UNIT	KLRC 40	KLRC 75	KLRC 100	KLRC 125	KLRC 200	KLRC 300	KLRC 525	KLRC 526	KLRC 950	KLRC 951
Speed	RPM	1750	1750	1750	1750	1750	1750	1750	1450	1150	860
Drive	Type	Direct	Direct	Direct	Direct	Direct	Direct	Direct	Belt	Direct	Belt
Standard motor	HP kW	5 3.8	5 3.8	7.5 5.6	10 7.6	15 11.4	25 19	50 38	40 30.4	100 74.6	75 55.9
Sealant liquid required (at 60° F w/ no sealant recovery)	GPM L/min	5 19	5 19	6 23	7 26	8 30	12 45	18 70	18 70	26 98	26 98
Sealant liquid required (at 60° F w/ partial sealant recovery)	GPM L/min	3 11	3 11	4 15	4 15	4 23	6 30	9 45	9 45	13 49	13 49
Liquid required to fill a Full Sealant Recovery (FSR) System	US Gal Liters	4.6 18	5 19	6 23	6.3 24	7.5 28	9 34	24 91	24 91	—	—
Cooling fluid at 60° F required for HX*	GPM L/min	5 19	5 19	7 27	10 28	15 57	25 95	50 190	50 190	52 197	52 197
Sealant Liquid Connections	NPT	1/2"	1/2"	3/4"	3/4"	1"	1"	1 1/4"	1 1/4"	1 1/2"	1 1/2"
Inlet/Outlet Flange	**ANSI 150 Class	1 1/2"	1 1/2"	1 1/2"	1 1/2"	2"	2"	3"	3"	4"	4"
Overall Length	in mm	22.6 573	24.1 613	25.8 654	28.1 713	29.7 754	33.6 852	41 1041	41 1041	56.5 1435	56.5 1435
Overall Height	in mm	12.6 321	12.6 321	16 406	16 406	19.1 486	19.1 486	23.5 597	23.5 597	30.56 776	30.56 776
Width	in mm	11.9 302	11.9 302	12.8 324	12.8 324	16.9 429	16.9 429	18.9 479	18.9 479	25.32 643	25.32 643
Shaft Height	in mm	6.5 165	6.5 165	6.9 175	6.9 175	8.3 210	8.3 210	9.8 249	9.8 249	12.59 320	12.59 320
Weight, Net Pump only	Lbs. kg	155 70	200 91	230 104	255 116	360 163	405 184	800 363	800 363	1590 721	1590 721

\* The HX cooling fluid flow rates are based on sealant fluid entering the HX at 80° F and exiting at 65°F. Cooler or warmer fluid than 60° will effect the flow rate.

\*\* (ANSI) American National Standards Institute

## THEORY OF OPERATION

When the pump is in operation, a continuous flow of sealant liquid is entering the pump and forms a seal between the impeller and casing (see Figure 1). The impeller is off-set above center of the pump casing and as the impeller rotates, pumping action begins in the space between the impeller and casing by filling and emptying similar to a reciprocating compressor (engine). Gas inlet and discharge ports are positioned so as to draw gas into the cavity inside the liquid sealed ring during the expansion segment, and discharge gas along with some liquid during the compression segment.

The discharged liquid can be recovered and recirculated through the use of a gas/liquid separator.

An attenuation valve is provided to drain sealant from the pump before starting and to bleed air into the pump to prevent cavitation, which occurs, when the pressure is low and the airflow is minimal. To additionally protect against cavitation an optional air bleed valve and/or vacuum relief valve can be installed in the suction line.

Water is normally used as a liquid seal, but may be unsuitable for some pump applications, Tuthill Vacuum & Blower Systems should be consulted before changing to a different liquid in the pump.

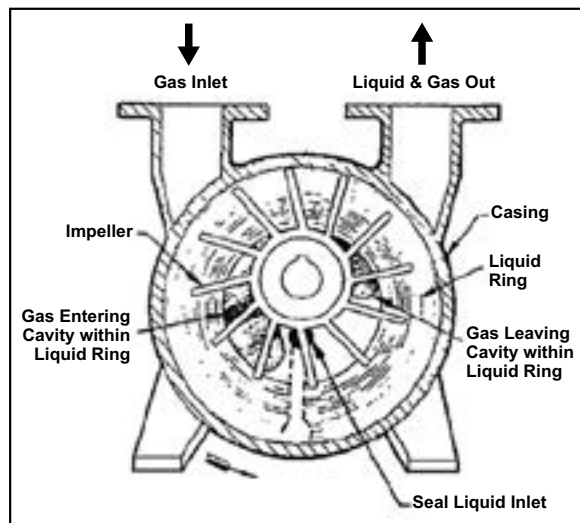

Figure 1. Cross Section Liquid Ring Pump

## PROPERTIES OF SEALANTS

Water is the most commonly used sealant in liquid ring vacuum pumps. Other fluids may be used to obtain process compatibility. In these applications special consideration should be given to the properties of the sealant, which may affect pump performance. Some of the properties of sealant which should be considered, are:

- Specific Gravity
- Specific Heat
- Viscosity
- Vapor Pressure

Additionally the solubility of process gas in the sealant can be of significance and should be evaluated especially if the partial or full recovery system is used. When water is the sealant its chemical content should be evaluated since certain conditions will affect the service life of the pump. Generally if water is suitable to drink it is suitable for pump use. Hardness greater than 500 PPM will result in internal plating and fouling of pump parts. Service with hardness of less than 500 PPM depends upon operating temperature and the nature of the mineral deposit. Naturally occurring well water with organic acid of pH-5 or higher is generally suitable, however pH of 7 or higher is preferred. Chemically treated water with sulfur content requires pH-7 or more. Water, which has a pH less than 5 should be treated or the pump should have special materials of construction. If internal scaling affects performance, a water treatment specialist should be consulted. Tuthill Vacuum & Blower Systems recommends that sealants and sealant systems be carefully evaluated and we invite you to discuss them with your Tuthill Vacuum & Blower Systems Sales Professional or our Application Engineers.

VAPOR PRESSURE  
OF WATER (Table 2)

WATER SEALANT TEMPERATURE °F	VAPOR PRESSURE TORR
50	9.2
52	9.9
54	10.7
56	11.5
58	12.3
60	13.3
62	14.2
64	15.3
66	16.4
68	17.5
70	18.8
72	20.1
74	21.5
76	22.9
78	24.5
80	26.2

## SEALANT TEMPERATURE

The rated capacity (ACFM) of a pump is based upon the use of incoming seal water at 60c F. Seal water temperature affects the pump capacity. Table 2 provides data which when applied to the below formula will give the pumping capacity on dry air at water temperature other than 60 °F. To calculate pumping capacity (ACFM) or to approximate the capacity when using water at other than 60 ° F the following formulas apply.

$$S_a = S_{60} \times (P_1 - P_c) / (P_1 - 13.3)$$

Where:  $S_a$  = Actual capacity in ACFM, at  $P_1$   
 $S_{60}$  = Pump capacity with 60°F sealant at  $P_1$  (This data is shown on Data Sheet 4703.)  
 $P_1$  = Inlet pressure in. Torr  
 $P_c$  = Vapor pressure of sealant at actual sealant temperature

## INSTALLATION

### GENERAL

Pumps are partially filled with a water-soluble rust inhibitor prior to shipment. This solution should be drained or flushed from the pump. Drain pump by removing drain plugs.

Liquid ring pump units with pump and motor on a common base, can be located on any flat and level flooring suitable for their weight. The pumps are almost vibration free and foundation bolting is not normally required. Using elastomer machine mounting pads (Vibration Controls) is helpful to eliminate minor floor vibrations. When the base must be bolted to the floor, it should be shimmed as necessary to avoid any base distortion.

### DIRECT COUPLED DRIVE

Pumps shipped with the pump and motor directly coupled and mounted on a common base have been aligned prior to shipment and normally no further alignment is necessary. However, alignment should be checked and adjustments made if necessary prior to starting unit. Generally, when installing flexible couplings, the two shafts must be aligned to within .020 of an inch (maximum), and the coupling halves must be positioned on the shafts to be parallel to each other within .030 of an inch (maximum) when measured around the periphery of the coupling halves.

### V-BELT DRIVE

Before attempting to tension any V-belt drive it is imperative that the sheaves be properly aligned. V-belts should be replaced in sets and the sheaves should be positioned so as to allow the belts to be placed in the grooves without rolling them onto the sheaves. The following tensioning steps can be safely followed for all belt types:

1. With belts properly in their grooves, adjust the sheaves until all slack has been taken up.
2. Start the drive and continue to tension the V-belt(s) until only a slight bow on the slack side of the drive appears while operating under load conditions.
3. After 24 to 48 hours of operation the belts will seat themselves in the sheave grooves. Further tensioning may be necessary as described in Step 2.

Slipping (squealing) at start up is often evidence of insufficient tensioning. Belt dressing should not be used on V-belts. Sheaves

and V- belts should remain free of oil and grease. Tension should be removed from belts if the drive is to be inactive for an extended period of time.

**WARNING:** The belt guard or coupling guard must be properly secured in place at all times while the pump is running.

### SEALANT RECOVERY SYSTEMS

Figures 2 through 5 illustrate sealant configurations:

- Once-Through (Fig. 2)
- Partial Recovery (Fig. 3)
- Full Recovery with Circulating Pump (Fig. 4)
- Full Recovery without Circulating (Fig. 5).

**CAUTION:** Do not run the pump dry

### ONCE-THROUGH RECOVERY

This arrangement takes water directly from the water supply, through the pump and discharges it directly through a gas/liquid separator tank to an approved drain. This arrangement is most common on small pumps, in installations where water conservation is not a factor, or where contamination of sealant is not a factor. Optional valving arrangement is designed to conserve sealant flow and power and when pump is operating at high pressure (low vacuum).

The optional components are described on page 17.

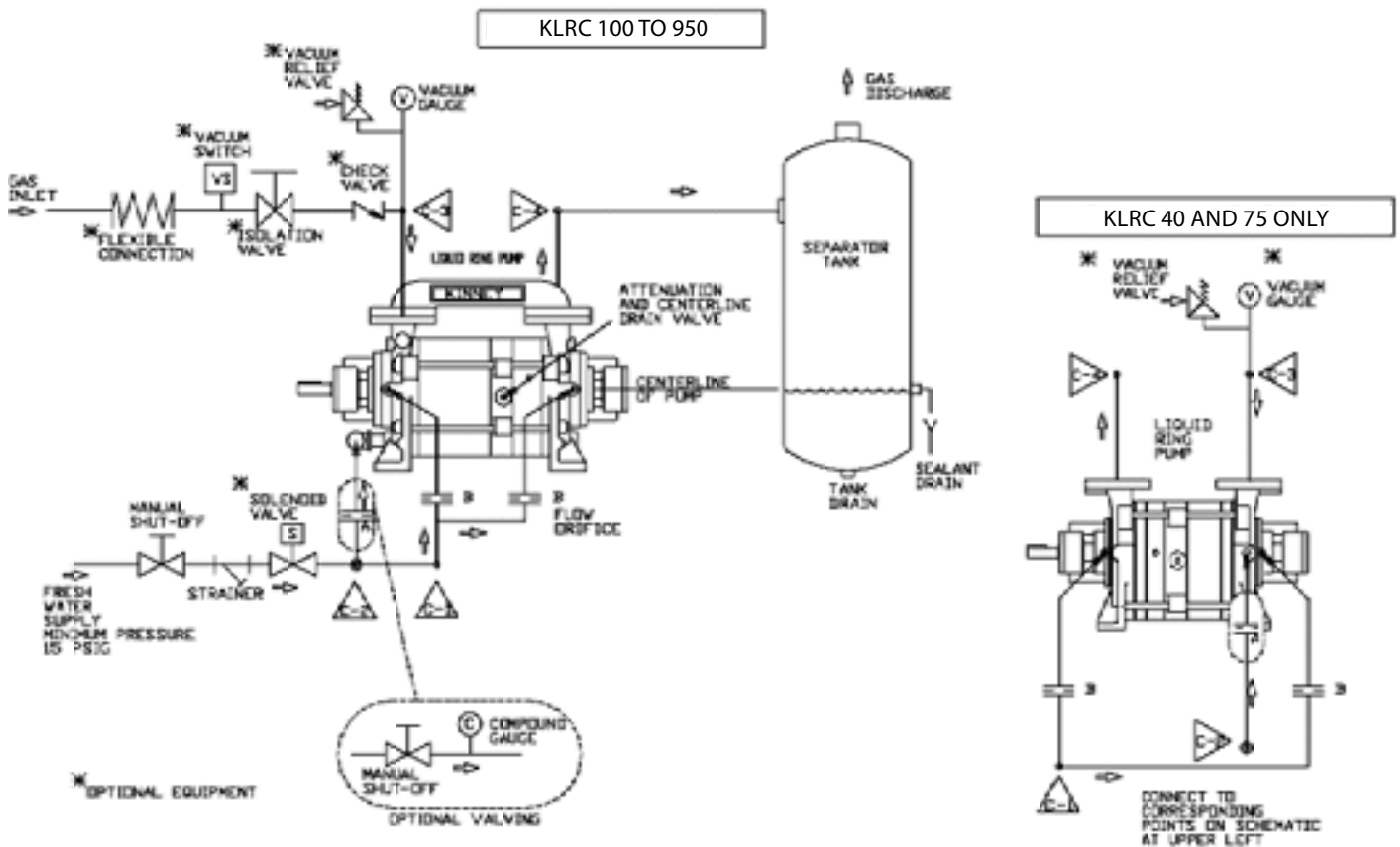

Figure 2. Piping Schematic Once - Through Recovery System

### PARTIAL SEALANT RECOVERY (PSR)

The partial recovery arrangement has the pump discharging water and gas into a gas/liquid separator tank, releasing the gas to atmosphere and retaining the water. Some water is disposed through an overflow and the remainder is retained in the separator tank for recirculation.

Makeup water is added in quantity necessary to maintain proper sealing water temperature. This is the most commonly used arrangement where sealing liquid conservation is required.

The optional components are described on page 11.

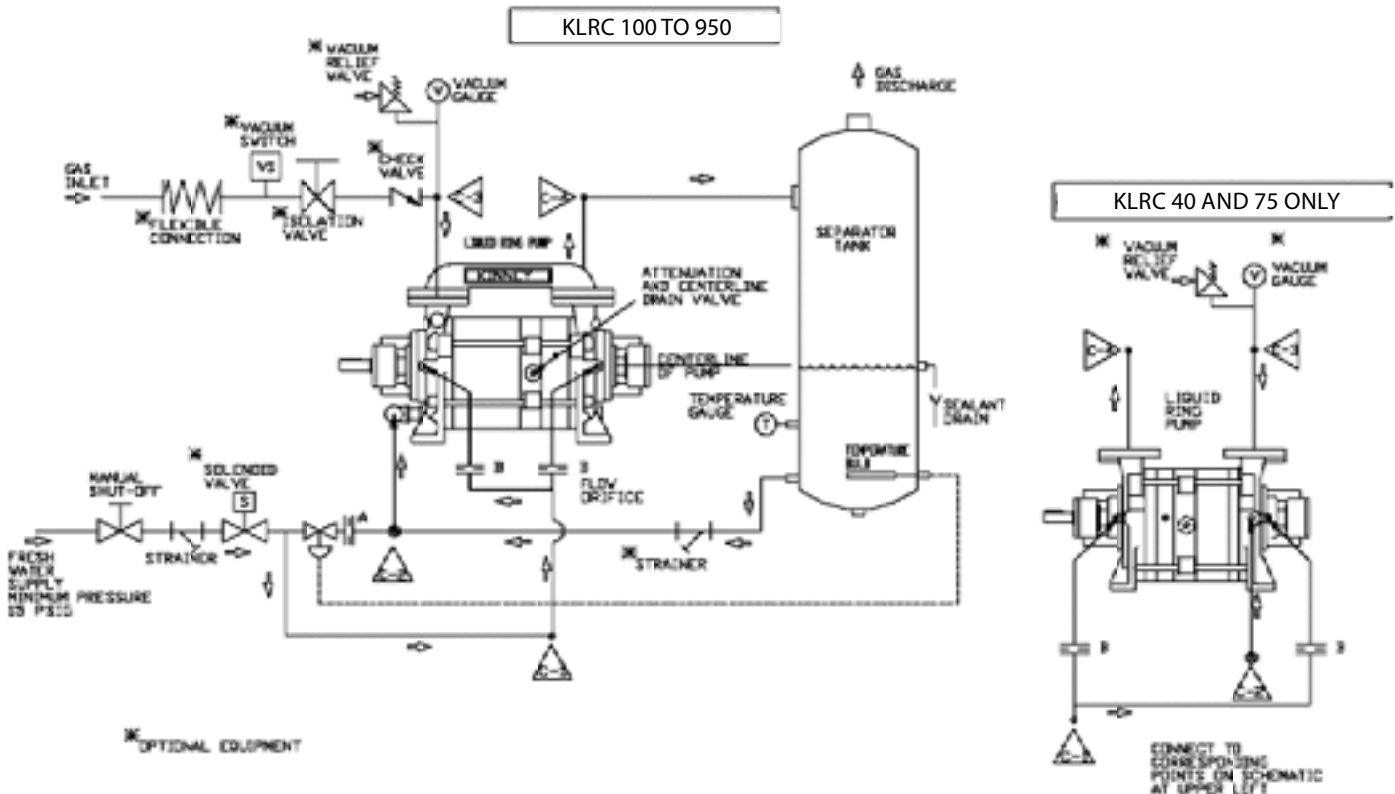

Figure 3. Piping Schematic Partial Sealant Recovery System

### FULL SEALANT RECOVERY (FSR)

A full sealant recovery system is a closed loop sealing configuration that employs a heat exchanger, (water or air-cooled) to maintain proper sealing fluid temperature. See Figure 4 for piping arrangement. This arrangement is not suitable for prolonged operation at pressure above 400 Torr unless a circulating pump is installed.

Full liquid recovery systems often operate under conditions where condensation would cause the liquid level to rise making it necessary to drain liquid from the unit in order to maintain the liquid level. The opposite condition can exist whereby liquid evaporation makes it necessary to add makeup liquid to maintain the liquid level. If there are extensive piping fittings and valves and other restrictive devices in the sealant line on a full recovery system that does not use a circulation pump, the sealant liquid is induced into the pump under pump suction entirely. For sustained operation above 400 Torr, on rapid cycling of pump down from atmosphere, a circulation pump may be required. A circulation pump, when added to a full recovery system maintains proper sealant flow at all inlet pressure conditions.

The pressure on the sealant gauge will vary depending upon the inlet pressure, from several inches of vacuum to a slightly positive pressure. The optional components are described on pages 14 and 15. Normally, a common supply line is used for both seal liquid and mechanical seal cooling.

The optional components are described on page 11.



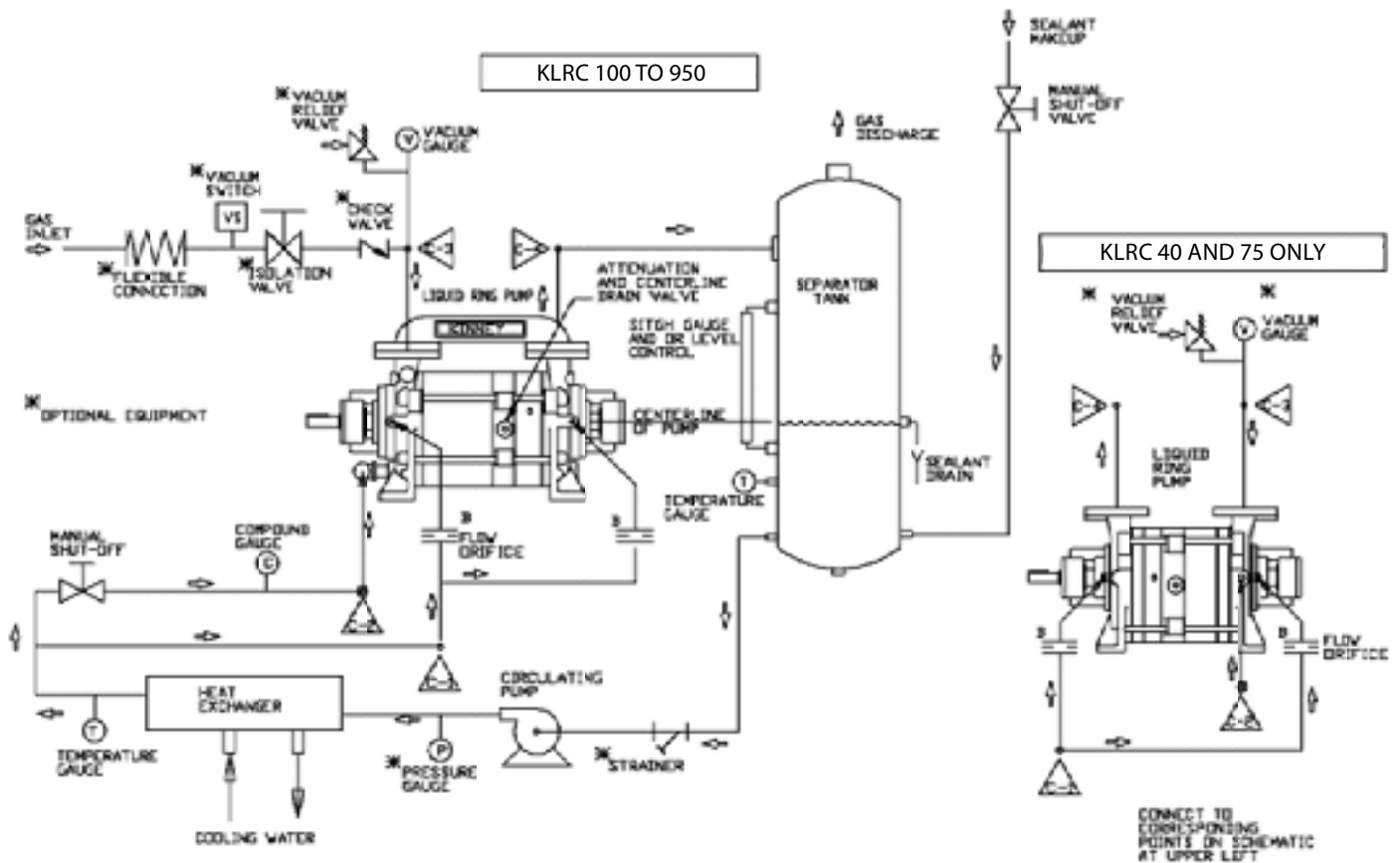

Figure 4. Piping Schematic Full Sealant Recovery System with Circulating Pump

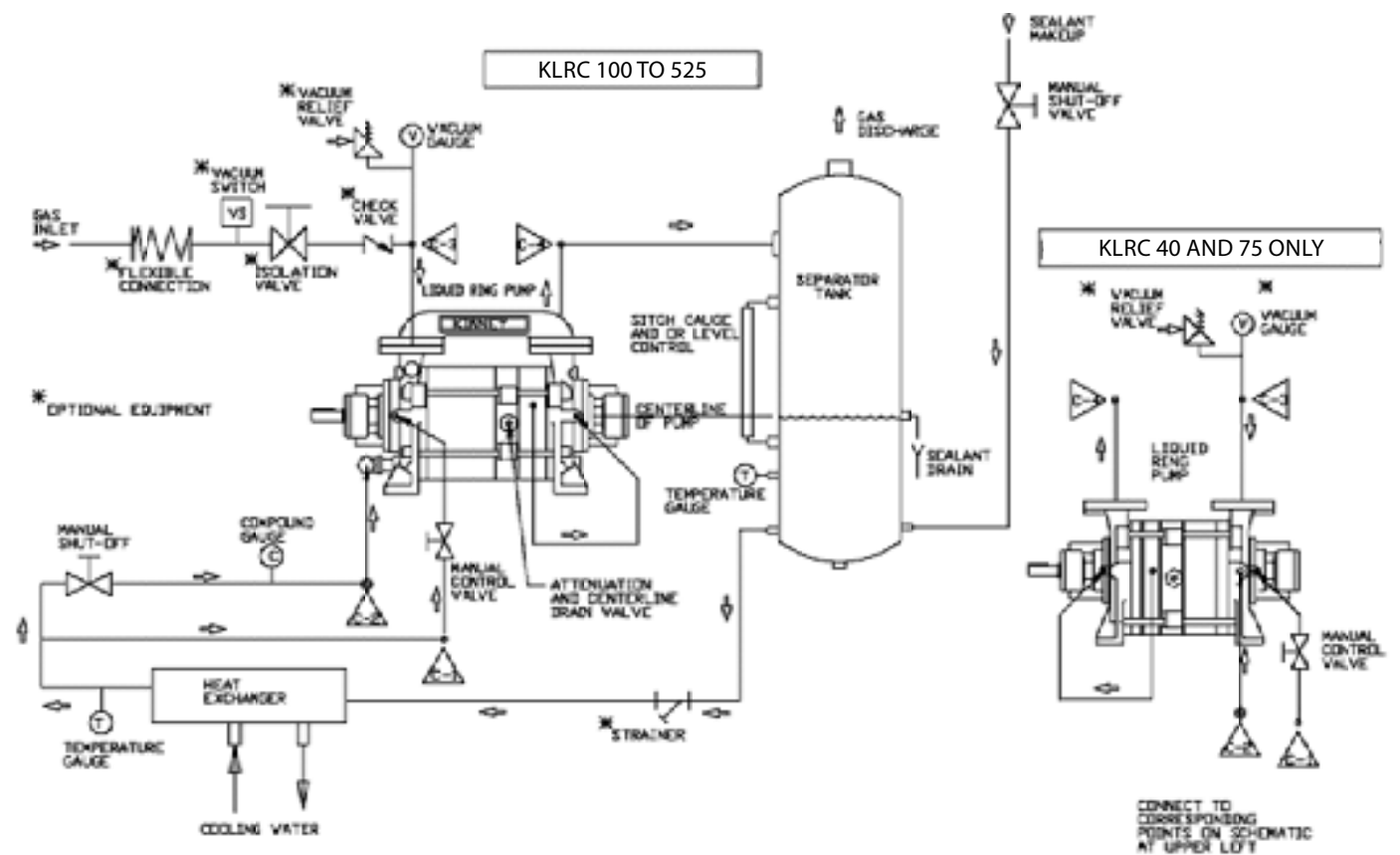

Figure 5. Piping Schematic Full Sealant Recovery System, Without Circulating Pump

SEALANT PIPING

See the Specification Table on page 5 for size of connections. Figures 2, 3, 4, and 5 show the connection locations for suction and discharge gas, sealant water and shaft seal cooling water of different pump models. Note that connections are different for KLRC-40 and -75 compared to the KLRC-100 to -950. Also shown are the valves and gauges as they should generally be located for any of the piping arrangements. Piping must be no smaller than the pump connection and must be aligned, and may have to be supported, so as not to place a strain on the pump.

Normally it is not necessary to drain a pump to shaft level prior to starting, provided that the incoming sealant flow was stopped simultaneously with stopping the pump during the last shutdown. An automatic solenoid valve (normally closed) is convenient for this use. The pump may be manually drained to shaft level by use of the attenuation valve.

As the pump creates its own vacuum it will draw in the required amount of sealant, so that the sealant need not be under pressure when pumping below 400 Torr. From 400 to 760 Torr, if the pump should operate for an extended period of time, a minimum of 7 PSI pressurized sealant would be required. The Specification Table on Page 5 provides the flow rates of water at 60 °F required for standard pumps at standard conditions. Recommended flow rates should provide an overall temperature rise of 10° F in a water-sealed pump.

Sealant flow rates and temperatures represent important considerations because of their effect on the heat balance of the pump. If the pump must operate over a broad vacuum range, flow rates are especially important. With too little water the unit will not pump at full capacity at higher vacuums, and with too much water the horsepower requirement will be excessive in the low vacuum range. Acceptable variations in flow rates shown in the Specification Table on Page 5 are on the order of +10% with no sealant recover, system, to +25% to -50% with partial sealant recovery systems. Full recovery systems have an optional sealant circulating pump that may be necessary if sustained operation above 400 Torr is anticipated.

## SEALANT FLOW CONTROL

The types of devices used to control the sealant flow depend upon the sealant arrangement used, the size of the pump, and individual preference. A low cost constant flow control device is generally used for no recovery systems and for the supply branch of partial recovery systems. Another method is to install an upstream adjusting valve and an intermediate pressure gauge. The valve can then be adjusted to obtain a specified pressure thus producing the desired sealing flow rate and gas inlet pressure. The latter procedure generally provides the most economical sealing flow rate. To achieve greater water conservation, the partial recovery system can be used with optional water miser and the fresh water flow adjusted for the highest operating temperature compatible with the process.

MODEL	Sealant flow (orifice) controller "A"		Shaft Seal flow (orifice) controller "B"	
	NPT	GPM / L/min	NPT	GPM / L/min
KLRC-40	3/4"	5 / 19	3/8"	1/4 / 1
KLRC-75	3/4"	5 / 19	3/8"	1/4 / 1
KLRC-100	3/4"	6 / 23	3/8"	1/4 / 1
KLRC-125	3/4"	7 / 27	3/8"	1/4 / 1
KLRC-200	1"	8 / 30	3/8"	1/4 / 1
KLRC-300	1"	12 / 46	3/8"	1/4 / 1
KLRC-525	1"	20 / 76	3/8"	1/2 / 2
KLRC-950	1 1/4"	25 / 95	3/8"	1/2 / 2

Table 3. Recommended Flow Controllers

With a partial recovery system an optional sealant flow control valve actuated by sealant discharge temperature may be used to automatically reduce fresh sealant flow when water temperatures are low. This will reduce sealant consumption below normal partial recovery flow rates. Fresh sealant flow may also be increased to achieve desired cooling and improve pump performance. In order to reduce sealant water consumption in once-through and partial recovery systems, a solenoid valve may be fitted to the sealant supply line. This valve will be integral with pump start/stop operation, thereby opening the sealant supply line during pump start up.

An automatic sealant make up valve and level switch will allow make up water to be added to maintain a predetermined level in the discharge separator. Conversely, if the system has a large amount of condensables and is adding liquid to the gas/liquid discharge separator, the above valve and switch can be used to activate a drain valve to lower the liquid level in the discharge gas/liquid separator.

When sustained operation is required above 400 Torr, or with rapid cycling on small volumes, an optional circulating pump is recommended. This will also apply for long roughing cycles. Also, if the pump RPM is below standard (1750 RPM), the use of a circulating pump should be considered. High sealant viscosity, and low specific heat and density, may require a greater sealant recirculation rate and the use of a circulating pump.

## COOLING PIPING FOR MECHANICAL SEALS

Sealant must be piped to the mechanical seals in order to keep the seal faces cooled and lubricated. The seals will fail if a suitable flow of sealant is not supplied. The sealant must be clean and free of particulates, dirt or grit will cause the seal faces to wear and fail prematurely. Connect the sealant piping to the seals as shown in Figures 2 to 5; Note that the connections to the pump are different for KLRC-40 and -75 compared to the KLRC-100 to -950.

## MANIFOLD PIPING

The suction and discharge ports are distinguishable by arrows on the pump, and are also shown in Figures 2 to 5. Note that the discharge port on the KLRC-40 and KLRC-75 are at the shaft drive end whereas on the KLRC-100 to KLRC-950 the discharge port is at the non-drive end. The discharge leg should not have more than 24 inches of elevation from the pump discharge flange. Too much elevation in this line would cause a build-up of back pressure, overload the motor and reduce the efficiency of the pump. During initial operation a screen should be installed across the incoming port of the suction end casing to prevent abrasive particles from entering the pump. The accumulation in the screen should be removed often enough to prevent restriction of gas flow, and the screen can be removed when particulate accumulation no longer occurs.

**CAUTION:** Newly installed manifolding must be clean, leak-free, and free of any weld slag. When the process produces particulates, which could damage the pump, a suitable suction line filter must be used.

**CAUTION:** The pump liquid sealant must not be allowed to freeze, in the piping or pump.

## ELECTRICAL CONNECTIONS

Standard electrical motors supplied with Kinney Liquid Ring Pumps are three phase 230/460 volts 60 Hz, across the line operation. Pump starting loads are low, as null load is developed at maximum RPM. Reduced voltage when starting is not required unless the power use is restricted by the plant power supply. Connect the pump motor and all applicable electrical accessories to a motor controller that has over-current protection (heaters or fuses) based on the full load current multiplied by the service factor as stamped on the nameplate. There should also be a suitable disconnect switch between the controller and the power supply.

After the motor starter and disconnect switch have been installed, turn the pump by hand to determine that the impeller(s) is free to rotate. Check the rotation by jogging the motor. An arrow on the drive end casing indicates the direction that the pump must rotate. If after wiring the motor the pump turns in the wrong direction, reverse any two of the power leads to the motor.

## SYSTEM COMPONENTS

The following are some of the components available for installation either when the pump is ordered, or later to be installed in the field. Accessories such as solenoid valves and flow switches can be added to meet particular needs. The air/liquid separator tank can be either the design that is mounted to the floor or the type that is suspended by the pump manifolding, depending upon the application.

**INLET ELBOW:** Used to adapt vertical pump inlet to horizontal for mounting inlet check valve etc. A similar elbow may be used to connect pump discharge separator tank.

**INLET VACUUM GAUGE:** Used to measure pump inlet vacuum. Standard 3" W dial gauge has brass bourdon tube and reads 0-30" Hg. The gauge is mounted at the pump suction. Stainless is available at an additional cost.

**INLET VACUUM RELIEF VALVE:** Used to control pump inlet vacuum. If pump capacity exceeds the system requirements at a preset vacuum, then the valve will open and admit ambient air or connected gas. Valve selection is dependent upon desired vacuum setting and pump size.

**INLET CHECK VALVE:** Used to automatically isolate pump from process chamber when the vacuum pump is shut down, by blocking the back flow of air and sealant. Valve must be installed in a horizontal position.

**FLEXIBLE CONNECTOR:** Used to accommodate some motion and misalignment between pump and system. Kinney Flexible Vacuum Connectors with steel flanges and stainless steel bellows are recommended.

**INLET SHUT-OFF VALVE:** Used to positively isolate pump from process chamber. Ball valves are supplied up to 2" NPT. Butterfly valves are supplied for connections larger than 2" NPT.

**SEALANT SOLENOID VALVE:** Used to establish sealant flow (open) when motor is energized, and return to closed position when motor is de-energized.

**FLOW CONTROLLERS:** Used to establish the sealant flow rate to the vacuum pump, and shaft seals. Recommended flow controllers are shown on page 10.

**SEALANT CIRCULATING PUMP:** Used to circulate recovered sealant. Required for use when operation at high-pressure such as frequent cycling, or when operating for prolonged periods above 400 Torr.

**STRAINER:** Used to filter solid particles from the sealant.

**HEAT EXCHANGER:** Used to cool circulated sealant.

## INLET AIR EJECTORS

An air ejector may be added to the inlet of a liquid ring vacuum pump to provide an additional pumping stage. The air ejector can achieve significantly lower pressure than is possible with the compound liquid ring pump alone, with no increase in horsepower. The operation of the air ejector is similar to that of a water eductor except that ambient air or recirculated discharge gas is used to provide the motive force for compressing the process gas from system pressure, to the liquid ring pump inlet pressure. The liquid ring pump handles both the process gas and the motive gas.

With an air ejector, a suction pressure as low as 3 Torr can be achieved. Using an air ejector, the pumping capacity between cut-in and 10 Torr is about 60% of the pumping capacity at 100 Torr: without the air ejector. To increase the pumping capacity above 30 Torr, an air shutoff valve may be added. To achieve the full pumping capacity- of the liquid ring pump above 30 Torr, a valved by-pass may also be added. Thus, the inlet air ejector can be combined with a liquid ring pump in three ways:

- Air ejector only.
- Air ejector with motive air shutoff valve (manual or solenoid).
- Air ejector with motive air shutoff valve and bypass manifold with valve.

The standard air ejector is cast iron with a series 300 stainless steel nozzle. All stainless steel ejectors are available upon request.

## OPERATION

### CAUTION:

Standard pumps with stainless steel impellers (designated with material codes F or C) are suitable for operation with sealant temperatures up to 160°F. Bronze impeller pumps (designated with material code B) and pumps with "HT" following the model designation on the nameplate are suitable for operation with sealant temperatures to 220°F. Operation with sealant at higher temperatures reduces internal clearances and will cause the pump to fail.

The pump performance curves are shown on the KLRC-series data sheets, which can be viewed at our site: <http://vacuum.tuthill.com>. The temperature of the sealant is a major factor in determining the base pressure, and influences the pumping speed. At lower temperatures the pump capacity increases, and at higher temperatures the pump capacity decreases. The temperature/efficiency ratio is not linear and the most pronounced effect is at low pump pressures.

When the pump is supplied with sealant water directly from a water main the water regulating valve must be adjusted so that the water enters the pump casing in the order of zero gauge pressure. If, however, the pump operates at a holding pressure above 400 Torr the sealant water pressure should be increased to about 7 PSIG. It is generally not recommended to run a liquid pump with the suction open to atmosphere for any period of time, as the pump will heat up due to the inability to draw in sealant to dissipate the heat.

## STARTING THE PUMP

If the pump has been idle for an extended period of time, it is advisable to turn the pump by hand prior to energizing the motor to determine that the impeller is free to turn.

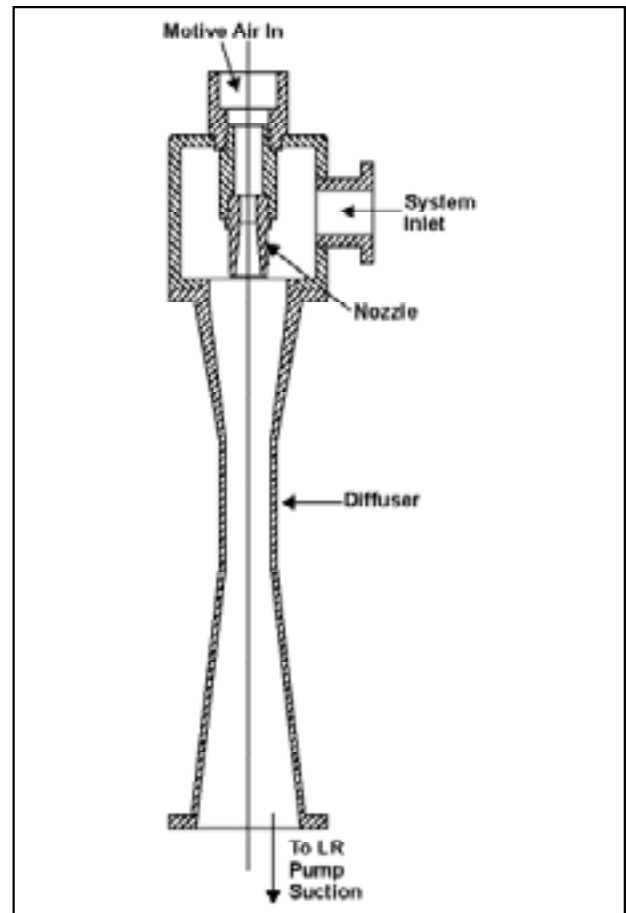

Figure 6. Air Ejector

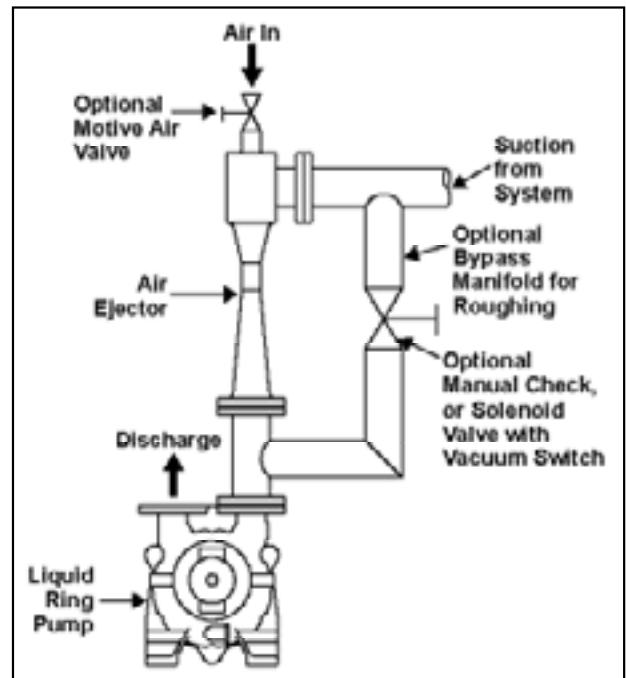

Figure 7. Air Ejector Installation

## PRESTART CHECKS

1. Check that the proper electrical power is connected to the control panel via the fusible disconnect.
2. Check that the sealant water supply to the vacuum system is adequate in terms of flow rate, temperature, and supply temperature.
3. Check that the proper sized inlet and outlet piping is connected to the vacuum system. Flexible connectors should be used between the pumps and piping to prevent external stresses from being applied to the equipment. On large diameter piping, pipe supports should be used to prevent the weight of the piping from stressing the equipment.
4. Fill the separator tank (if applicable) of the liquid ring pump with the correct sealant liquid to the level which corresponds appropriately to the shaft level of the liquid ring pump. At no time should the liquid level be allowed to drop below the sealant outlet connection which would allow gas to enter the suction of the circulation pump. Maximum sealant level would coincide with the top of liquid ring pump bearing housing.
5. A liquid level gauge is installed to allow visual monitoring of the sealant level. NOTE: The limitations on what sealant can be used in the liquid ring pump are based upon the following considerations: (a) The sealant should be compatible with the materials of construction and the process stream so that corrosion, polymerization, or some adverse chemical reaction does not occur. (b) The vapor pressure of the sealant must be compatible with the desired process pressure. (c) Specific gravity should be between 0.5 and 2. (d) Specific heat should be between 0.3 and 1. (e) Viscosity should be <45 cst at sealant operating temperature.
6. After filling the liquid ring pump and recovery system with sealant to the proper level, position the manual valves for start-up. (a) Check that the globe valve located in the sealant line between the heat exchanger and the liquid sealant. (b) Check that the two small valves located in the seal cooling lines leading to the mechanical seals on the liquid ring pump are both fully opened. These valves may be throttled down to halfway open later if slightly higher vacuum is desired, or if sealant pressure is high. Under no circumstances should the valves be closed more than one-half way.
7. On initial start-up, or if the pumps have been sitting idle for several weeks; rotate the pumps by hand several rotations to be sure that they are mechanically free.
8. Jog the motor to check the proper direction of rotation. Facing the drive shaft of each pump: The KLRC-40 & KLRC-75 liquid ring pumps rotate counter-clockwise. All other models rotate clockwise.

## INITIAL START UP

1. Turn on the main power by closing the external fusible disconnect switch or circuit breaker.
2. Check that all isolation and discharge valves (if fitted) are in the proper position.
3. Push the "START" button: The liquid ring pump should start immediately.
4. Turn on the sealant water.
5. Adjust the anti-cavitation valve to obtain best vacuum level without cavitating the liquid ring vacuum pump.
6. Check that the sealant flow to the mechanical seals is adequate.
7. Check that the cooling water flow to the liquid ring heat exchanger is adequate by checking the sealant temperature.
8. Check the sealant level in the separator tank. If necessary add or remove fluid.

## PROCEDURE FOR MINIMUM SEALANT FLOW RATE

The requirements for sealant flow, as shown in Specification Table on Page 5, are the maximum GPM for once-through, partial, and full recovery systems. To determine the minimum quantity of sealant flow: required for a specific application, proceed as follows:

For once-through and partial sealant recovery systems, with the pump on a system and operating at the desired operating inlet pressure, slowly decrease the flow of sealant liquid until the inlet pressure begins to fluctuate, and then gradually increase the flow until the pressure again becomes steady. This is the setting to be used for minimum seal flow as long as operating conditions remain constant.

Cavitation occurs when there is localized boiling of the sealant. This boiling action causes the formation and collapse of vapor bubbles, and the resultant shock forces cause erosion by tearing out metal particles. The damage can be especially severe in corrosive environments.

A loud rumbling sound is a sign that cavitation is occurring. It is easily suppressed by raising the inlet pressure above the vapor pressure of the sealant at its operating temperature by bleeding air or another comparable gas into the suction if opening the attenuation valve cannot be used or does not bleed in enough air.

When cavitation occurs, the pump sounds as though it has gravel in it. This noise will commonly occur when the pressure is low and the air or non-condensable gas flow is slight. Cavitation should be reduced or eliminated by bleeding air into the pump through the attenuation valve. If enough air can not be bled into the pump to satisfactorily quiet the pump, an air bleed valve should be installed. Non condensable gas may be recirculated by adding a return line from the discharge separator tank to the pump inlet bleed valve.

## STOPPING THE PUMP

1. Isolate the pump from the process chamber.
2. Shut off sealant liquid supply. (See Starting the Pump)
3. Shut off cooling sealant to the mechanical shaft seals.
4. Stop pump.

## TROUBLESHOOTING

CONDITION	CAUSE	REMEDY
Seals Leaking	Seal incorrectly installed	Re-install seal
	Seal worn or damaged	Replace seal
Reduced capacity	Rotational speed too low	Check supply voltage
	Vacuum leak	Locate and repair
	High sealant temperature	Check coolant flow and temperature Check heat exchanger cleanliness
	Incorrect sealant flow rate	See "Sealant flow rate"
Excessive noise	Defective bearing	Replace
	Too much sealant liquid	Decrease flow rate
	Coupling misaligned	Align
	Cavitation (defined on pg 13)	Open attenuating valve or reset vacuum relief valve to increase flow
Overheating	Defective bearing	Replace
	High sealant temperature	Check coolant flow and temperature
	Suction open to atmosphere	Adjust isolation valve
Excessive vibration	Coupling misaligned	Align
	Pump not properly anchored	Anchor
	See excessive noise	Check inlet pressure and gas flow
Motor overloaded	Excessive back pressure	Reduce height of pump discharge
	Too much sealant liquid	See table for proper flow rate
	Misalignment	Realign motor and pump
	Defective bearing	Replace bearing
Abnormal bearing wear	Misaligned pump assembly	
Impeller binding or will not turn	Accumulation of rust or scale	See "Operation" and "Maintenance"
	Foreign object in pump	Dismantle pump and remove foreign object
Mechanical Seals squeal	Insufficient cooling liquid	Increase coolant flow to seal, check compatibility of sealant

## MAINTENANCE

### GENERAL

WARNING: DISCONNECT PUMP FROM ELECTRICAL POWER SOURCE PRIOR TO MAKING REPAIRS OR ADJUSTMENTS TO ANY ELECTRIC COMPONENTS OF THE UNIT. Elementary rules of cleanliness, periodic inspections, and a preventative maintenance policy of the pump will produce optimum performance and prolong the life of the pump.

### SHAFT BEARINGS

The two shaft bearings should be lubricated every 1500 hours of operation or every two months. A high temperature grease with an extreme pressure (EP) additive is recommended. Grease should be added through the grease fitting while the shaft is turning. The temperature of the bearings should not exceed 140°F (hot to touch), unless special grease is being used after consulting Tuthill Vacuum & Blower Systems.

## SCALE OR RUST ACCUMULATION

If scale or rust accumulates and hampers the efficiency of the pump, remove the scale or rust by circulating an inhibitor selected according to the nature of the buildup.

## MECHANICAL SHAFT SEALS

If the mechanical seals are leaking they should be replaced or reconditioned. Some mechanical shaft seal manufacturers have a seal reconditioning program, which we recommend where available.

When replacing the mechanical seal, clean the shaft thoroughly where the previous seal may have bonded to the shaft. Figures 9, 10, 11 & 12 show the mechanical shaft seals that are commonly used on Kinney liquid ring pumps. The seal faces must be protected during installation from particles that may scratch the surfaces. Before installing the elastomers, the shaft and elastomers should be lubricated with a lubricant compatible with the pumping process for ease in installing and better positioning on the shaft.

CAUTION: Do not run the mechanical seal without coolant.

## PREPARATION FOR STORAGE

If the pump is to be idle for an extended period of time it should be preserved internally to prevent rust, if the sealant liquid is water or water soluble liquids. The pump can be preserved temporarily (2 to 3 months) by adding a water-soluble rust inhibitor into the pump. For longer periods of preservation, drain the pump by removing the drain plugs. When the draining is completed and all drain plugs have been replaced, fill the pump to 1/3 to 1/4 full using Shell Oil Company, VSI, SAE-25 (SAE-33 or SAE-37 can be used) or Antifreeze. Rotate the pump by hand to coat the interior of the pump with oil.

	DISASSEMBLY	ASSEMBLY
NDE Shaft seal replacement	1	7
NDE Stage only	1 + 2	6 + 7
DE Shaft seal replacement	3	4
DE Stage only	3 + 4	2 + 3
Total Disassembly	1 - 5	1 - 8

## SPARE PARTS

Figures 11, 12, 13 and 14 are cross section views of the pumps represented in this manual. A set of recommended spare parts for each pump model operating should be available as initial spare parts. When ordering parts, the pump nameplate information must accompany the order along with the part reference number and name.

## DISASSEMBLY

### GENERAL

KLRC liquid ring pumps incorporate two sets of tie-rods, which fasten either stages, or ends of the pump, to the center housing. This allows independent work on each stage. The stages are referred to as drive end (DE) and non-drive end (NDE). For models 100 through 525 the suction flange and the longer first stage are located at the drive end, and the discharge flange and shorter second stage are located at the non-drive end. For models 40 and 75, which do not have a crossover pipe, the suction flange and first stage are located at the non-drive end, and the discharge flange and second stage are located at the drive end.

Repair on the pump is most easily accomplished with the pump axis in a vertical position. Adequate support is provided by pump stands as shown in Figure 8. Disassemble a pump only to the extent necessary for repair. Applicable disassembly and assembly steps are as follows:

### DISASSEMBLY PROCEDURE

Remove pump from installation and drive coupling with drive key from pump shaft. Drain sealant fluid from pump by removing all 1/4" NPT drain plugs.

#### 1 NDE SHAFTSEAL

- 1.1 Position pump vertically on support stand, NDE up.
- 1.2 Remove NDE bearing housing cap.
- 1.3 Remove bearing housing flange screws and use two in threaded holes to push-off bearing housing.
- 1.4 Remove the loose elastomer flinger, the shaft seal seat, and the ball bearing from the bearing housing.
- 1.5 Remove the shaft seal head from the shaft. Because various shaft seal types with different length can be used in the seal cavity, some seals require the use of seal spacer washers between seal head and impeller locknut. For identical seal replacement these spacers must be reused.

Note:

(a) For NDE shaftseal replacement only continue with Reassembly Step 7.

(b) For disassembly of the NDE stage only or complete disassembly, continue with Disassembly Step 2.0.

## 2 NDE STAGE

2.1 Remove the crossover pipe at connecting flanges.

2.2 Remove NDE tie rod nuts and lift off the NDE end casing. Remove the endplate from the end casing only if it needs to be replaced.

2.3 Remove the impeller housing.

Note: Verify that further disassembly is necessary if:

(a) The impeller nut and locknut are not secure.

(b) The impeller has to be replaced, or requires a major cleaning.

(c) If the center housing has to be replaced, it can be removed by following steps 2.4-2.6. However, if a complete pump disassembly is required, temporarily reassemble the impeller housing and end casing with three or four tie rod nuts, then invert the pump and continue with step 3.

2.4 Loosen and remove the impeller lock nut; then loosen and remove the impeller nut (thin nut). Note the threading:

KLRC-40 & 75: Left Hand Thread CW to loosen

KLRC-100 - 950: Right Hand Thread CCW to loosen

2.5 Lift off the impeller and note the direction of the blade for reassembly.

2.6 Remove center housing by disassembling tie rod nuts at the DE end casing.

## 3 DE SHAFTSEAL

3.1 Position pump vertically on support stand, DE up.

3.2 Remove DE bearing housing cap and bearing lock nut with a spanner wrench.

3.3 Remove DE bearing housing (with nameplate). Same as Step 1.3.

3.4 Remove the loose elastomer flinger, the shaft seal seat, the double row ball bearing and bearing spacer from the bearing housing.

3.5 Remove shaft seal same as step 1.5.

Note:

(a) For DE shaft seal replacement only continue with Reassembly Step 4.0.

(b) For disassembly of DE stage or complete disassembly continue with the next step.

## 4 DE STAGE

4.1 Remove the crossover pipe at connecting flanges (if not already removed).

4.2 Remove the DE tie rod nuts and lift off the DE end casing. Remove the endplate from the end casing only if it needs to be replaced.

4.3 Remove the impeller housing .

4.4 Remove shaft lock nut and impeller nut. Same as Step 2.4 except note that nut threading is in the opposite direction on this end of the respective pump models:

KLRC-40 & 75: Left Hand Thread CW to loosen

KLRC-100 - 950: Right Hand Thread CCW to loosen

4.5 Remove impeller and note direction of blade for reassembly.

## 5 CENTER HOUSING AND NDE STAGE

5.1 Remove NDE tie rod nuts and lift off the center housing with both sets of tie rods.

5.2 Lift off the NDE impeller housing.

5.3 Lift the shaft with NDE impeller attached from the NDE end casing.

5.4 Disassemble the shaft/impeller only if the impeller locknut is not securely fastened and indicates fuller inspection, or if either part needs to be replaced.

# REASSEMBLY

## GENERAL

All pans must be clean. Clean off old sealant film at housing interfaces, and removed with an effective solvent. All joint and impeller faces must be free of any nicks.

Note:

(a) Standard cast-iron construction FA and BA pump housing joints are sealed with Loctite Corp./Permatex Aviation Form - A - gasket liquid sealant 3H, thinning solvent Denatured Alcohol.

(b) Stainless steel pumps CD3 are assembled with PTFE glass filled gaskets in lieu of sealant



Note: Iron pumps designated for Hot Operation (220°F Limit) are assembled with paper shims and Gasket liquid sealant 3H.

- (c) Sealant (when used) must be applied lightly on one surface of joint with a small stiff brush. The sealant can must be capped when not used to avoid solvent evaporation. If needed use listed thinner to maintain original fluid consistency.
- (d) Assembly should proceed without interruption until tie rods for the pump are half tightened to prevent early setting of sealant.
- (e) The following torque values (ft-lbs.) apply for fasteners. Always replace the end plate screws; use new stainless steel cap screws with nylon locking inserts. DO NOT REUSE THE OLD SCREWS.
- (f) For installation with multiple pumps and in-house repair, it is helpful to have cast-iron dummy bearings with outside diameter .001" smaller than, inside diameter .001" larger than, and width equal to the NDE ball bearing.
- (g) Ball bearings for pump models -HT (as shown on the nameplate), prior to August 1998 are lubricated with special high temperature grease and are etched on the outside diameter "Spec. lube." They should not be replaced with standard bearings.

PUMP MODEL	END PL* SCREWS	TIE-ROD NUTS	BRG HSG SCREWS
40/75	20-25	40-45	25-30
100/125	15-20	40-45	25-30
200/300	20-25	40-45	30-35
525	25-30	60-65	40-45
950	25-30	70-75	40-45

## REASSEMBLY PROCEDURE

### 1 NDE IMPELLER/SHAFT

1.1 If the NDE impeller was removed from shaft - install drive key and impeller on shaft - looking at the NDE of shaft, the curvature of the impeller blades must be: Clockwise on models 40/75 and counterclockwise on models 100-525.

Note:

- (a) Install and wrench tighten the impeller nut and when seated, apply one hammer blow to the wrench. Then install the impeller lock nut and again when seated apply one hammer blow to the wrench.
- (b) If a dummy NDE bearing is not available, assure that the ball bearing fits on the shaft bearing journal with a very light tap or slip fit.

1.2 Temporarily install a dummy or ball bearing, and a bearing cap in the NDE bearing housing, then attach it to the NDE end casing.

Note:

- (a) To differentiate end casings, note the DE casing, for models 300-525K, has the fluid sealant supply port centrally located under the bearing housing. In models 40/75K the supply port is located on the outside periphery of the NDE end casing at centerline height.

### 2 NDE STAGE

- 2.1 Position the NDE end casing/bearing housing assembly on the assembly stand. If the NDE endplate (with shaped suction port for models 40/75, and smaller discharge port for models 100-525) was removed, apply sealing compound to the counter bored sealing face. Note: for stainless steel models use the PTFE glass filled gasket in lieu of sealant. Install the plate - full face up - slightly rotating it to distribute sealant (if used), while lining up the bolt holes. Fasten with Nylon pellet or patch screws torque per the Specification Table on Page 5.
- 2.2 Insert the NDE of shaft/impeller assembly into the bearing, so that the impeller face rests on the end plate. A dummy bearing is helpful for an easy fit at this step.
- 2.3 Apply sealing compound to the male end of the NDE impeller housing, (for 40/75 models with two male ends, check the cross sectional drawing for correct end), and install it aligning the cast-in index marks on top of housing and end casing. Tap it with a soft hammer for proper searing. Then apply sealing compound to the top end face. Note: for stainless steel models use the PTFE glass filled gasket in lieu of sealant.
- 2.4 Place the center housing with tie rods, drain holes at bottom, onto the impeller housing with tie rods entering the end casing holes. Align the indexing marks and tap it down.
- 2.5 Assemble washers and nuts to tie rods and tighten in a crisscross pattern in several incremental steps with a clicker torque wrench. For example: 30, 40-ft lbs. The assembly position does not allow easy reading of a dial torque wrench. Finally, torque per the Specification Table on Page 5.

### 3 DE STAGE

- 3.1 Install impeller drive key and impeller on shaft - looking at the DE of shaft end, the impeller blades must be pointing:  
 KLRC-40 & 75: Counterclockwise    KLRC-100 - 950: Clockwise  
 Proceed with retaining washer, impeller nut, and washer locking bend as at step 1.1 Shaft rotation should be prevented

- with a spanner wrench at the drive end keyway. (This washer is found on the old style KLRC pump only)
- 3.2 Apply sealing compound to the matching end of the DE impeller housing (for 100-525 models with two male ends, align tooling tabs with those on the NDE impeller housing), and install it aligning the top index marks on the center housing. Note: for stainless steel models use PTFE glass filled gaskets in lieu of sealant.
  - 3.3 If the DE endplate (with shaped suction and discharge ports for models 100-525, and one discharge port for models 40/75) was removed from the DE end casing, follow Step 2.1 for its assembly.
  - 3.4 Place the DE end casing/plate assembly on top of the impeller housing with tie rods entering the bolt holes and align index marks. Assemble washers and nuts to tie rods and lightly tighten them.
  - 3.5 To assure correct alignment of the feet of both end casings, an alignment bar as shown in Figure 14 can be bolted to the end casing feet to get correct radial alignment. Then loosen one bolt lightly and tighten the tie rod nuts as in Step 2.5
  - 3.6 The sealant fluid supply pipe elbow must be installed if it was removed.

#### 4 DE SHAFT SEAL AND BEARING HOUSING

- 4.1 If the lip (oil) seal has been damaged during the disassembly process, replace it at this time using the proper tooling.
- 4.2 Install shaft seal spacer washer on the shaft against the impeller nut for use with the John Crane shaft seal, standard in cast-iron pumps (Kinney version FA and BA). No spacer is used with Flowserve shaft seal, standard in stainless steel pumps (Kinney version CD) or optionally in cast-iron pumps, for example FD2 models.
- 4.3 Remove carbon from seal head, Kinney style "A" only (John Crane Type 21) and push seal elastomers boot onto a very lightly greased (vacuum grease) shaft against the washer, then re-install carbon with proper notch alignment. When installing Kinney style "D" (Flowserve type RO) assure that the drive dowel pin is aligned with, and enters the clearance hole in the impeller locknut.
- 4.4 Install the shaftseal seat, with lightly greased (vacuum grease) seal element and lapped surface facing out, into the DE bearing housing (with attached pump nameplate). Place O-ring into bearing housing flange groove. Insert flinger into housing gap, and install both on shaft and against end housing, assure proper seating - the shaftseal spring compression will give some resistance - and install bolts with lockwashers torque per the Specification Table on Page 5.
- 4.5 Install bearing spacer washer on shaft. Washer thickness is stamped on front of DE bearing housing - for example 57 would indicate .057" thick bearing washer. Install the double row ball bearing on shaft and into housing using proper tooling. Install bearing locknut with spanner wrench, while holding shaft with another spanner wrench in the drive keyway, until hand tight, then hammer tap until solid resistance is felt. Install DE bearing cap with lock washers and screws. NOTE: On a typical KLRC repair the factory shim setting should be reused. In the event that the shim is damaged a shim of the same size can be ordered from the factory of that exact size. (see Section 9.0)

#### 5 NDE ASSEMBLY PREPARATION

- 5.1 Invert the pump assembly on the assembly stand. Remove the temporarily installed bearing housing, bearing cap. and dummy or ball bearing.  
Note: If continuing with a complete reassembly skip to Step 7; if only reassembling the NDE side go to Step 6.0 below.

#### 6 CENTER HOUSING AND NDE STAGE

- 6.1 If the center housing and DE impeller housing were removed, follow assembly steps 3.2 - 3.5 to reinstall.
- 6.2 If the NDE impeller was removed from shaft - reassemble as in Step 1.1.
- 6.3 Position the NDE impeller housing for correct match with center housing and DE impeller housing, then apply sealing compound to the matching end and install with a slight rotating movement while aligning the cast-in index marks. Note: if the unit is stainless steel use PTFE glass filled gaskets in lieu of sealant.
- 6.4 If the NDE endplate was removed from the NDE end casing reassemble it as in Step 2.1.
- 6.5 Place the NDE end casing/plate assembly on top of the impeller housing with tie rods entering the bolt holes and align the index marks. Assemble washers and nuts to tie rods and lightly tighten them.
- 6.6 For alignment of feet and tie rod torque nuts follow Steps 2.5 and 3.5.

#### 7 NDE SHAFTSEAL AND BEARING HOUSING

- 7.1 Shaft seal spacer washers follow Step 4.2.
- 7.2 For seal head assembly follow Step 4.3.
- 7.3 For NDE bearing housing assembly follow step 4.4.
- 7.4 Install the single row ball bearing on shaft and seat into bearing housing. To avoid relative displacement of inner and outer bearing races with slight interference fit use a bearing driver as shown in Figure 13. Then install NDE bearing cap with lock washers and screws.

#### 8 CROSSOVER PIPE

- 8.1 Assemble crossover pipe with gaskets to both end casings -facing the drive end to the left DE end casing flange, and the diagonal NDE end casing flange. Within the available play of the studs in the flange holes, match the flange outside diameters as best as possible.

9 CLEARANCE CHECK AND ADJUSTMENT

If replacement of casings or housings (end, center or bearing) occur during the repair of a KLRC pump shim thickness will need to be re-checked. Included in the KLRC repair kits is one shim of the largest size, this can be ground to the dimension to achieve the same result. Dummy bearings will be required to accomplish this task. The dummy bearings should be made based on the dimensions of the bearings supplied for the pump model less .002" in OD and increased by .002" in ID. Mild steel or an equivalent material is acceptable for this. It may be advantageous to provide threaded holes to aid in removal of the dummy bearing. NOTE: If a shim change is required on a "hot pump" or stainless steel pump please contact the factory for further information.

The required shim dimension can be found as follows:

1. Move the shaft of the assembled pump fully towards the NDE of the pump.
2. With the bearing cap removed, using a depth micrometer measure to the dummy bearing from the bearing housing surface. Record the reading.  
With the assistance of a gear puller, push the shaft completely towards the DE of the pump.
3. Using a depth micrometer measure to the dummy bearing and record the reading.
4. Subtract the smaller reading from the larger; this number is the total clearance of the pump.
5. The shim size is one half of the total clearance within the pump.

KLRC-40  
through  
KLRC-525

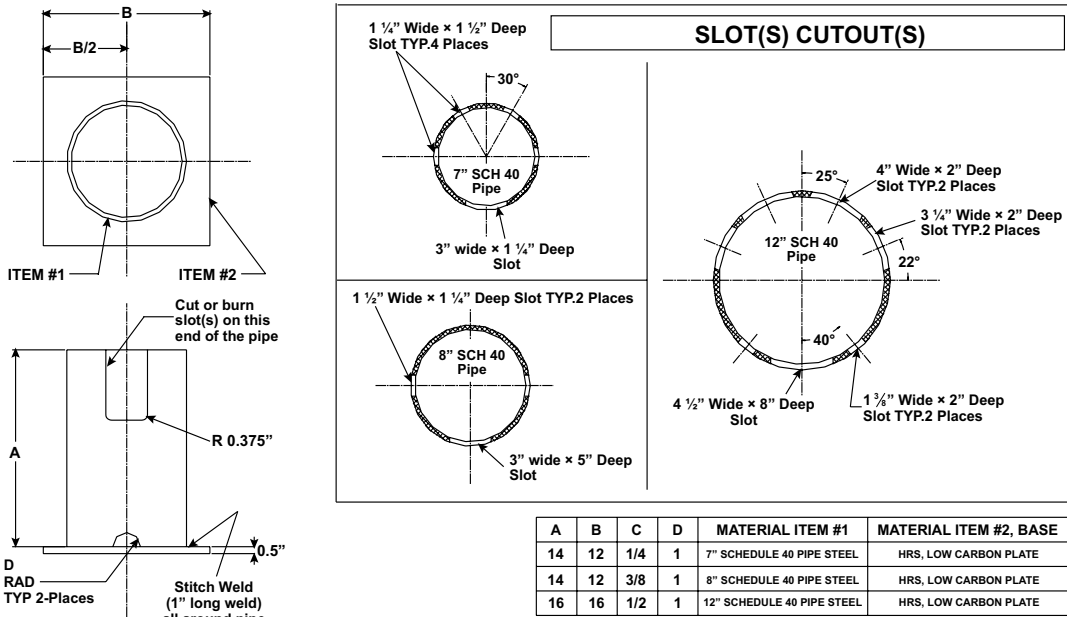

KLRC-950

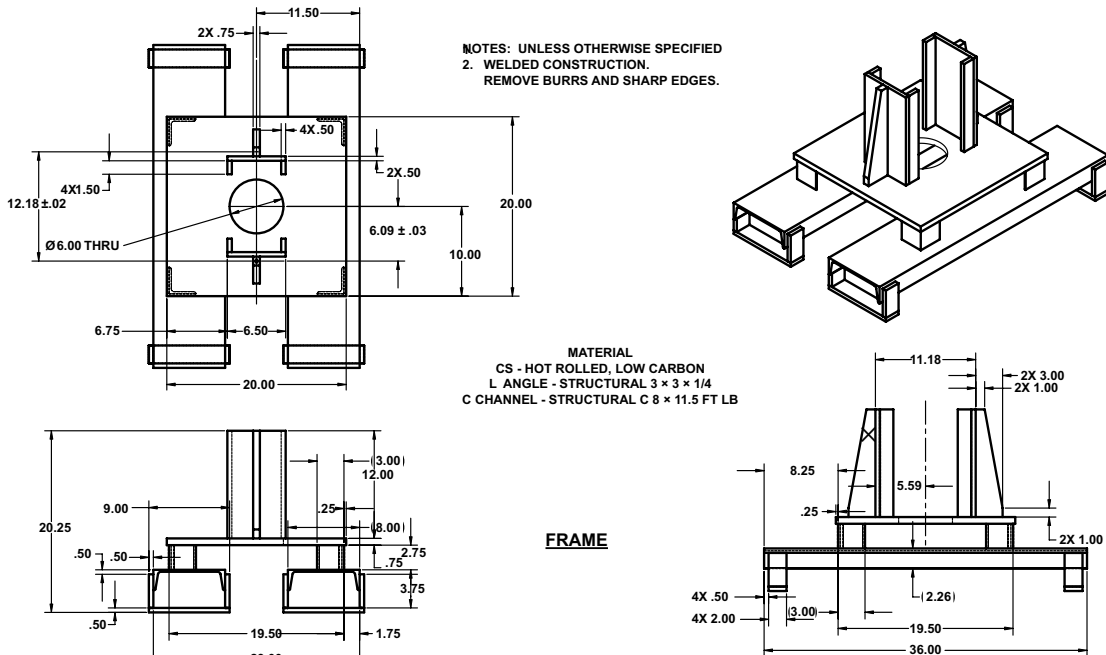
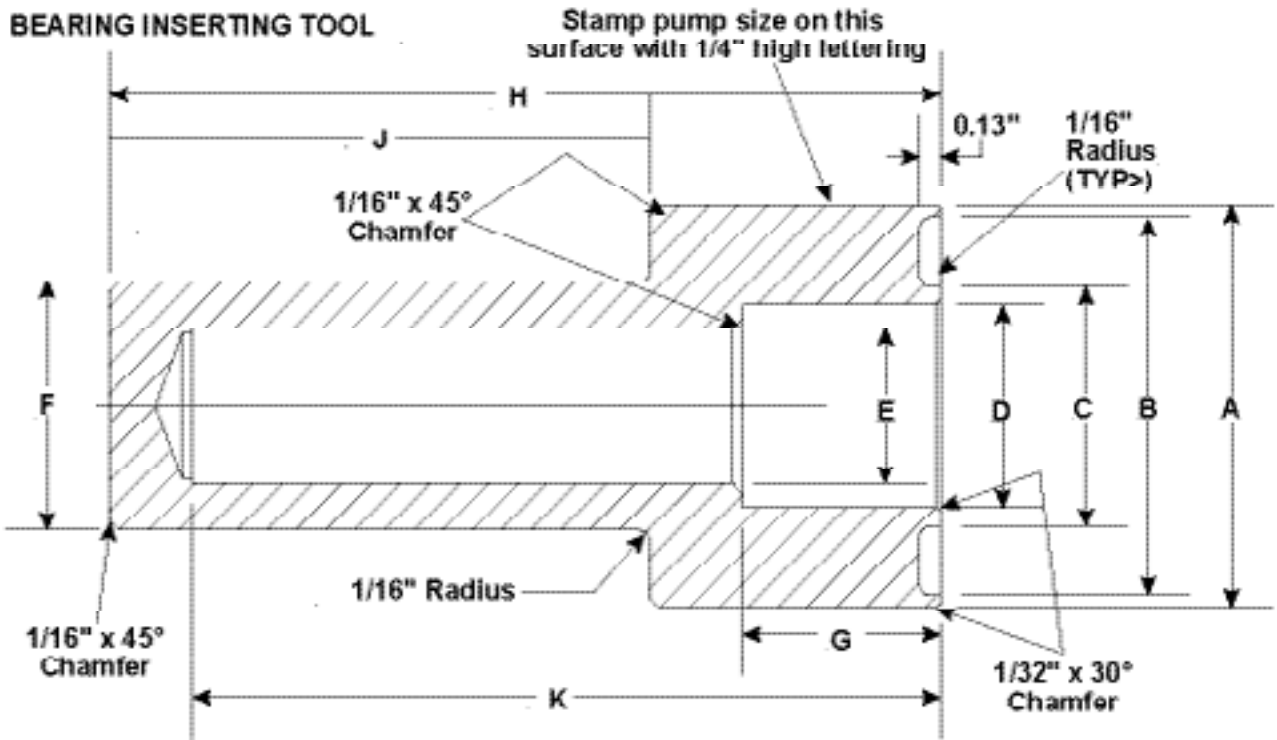
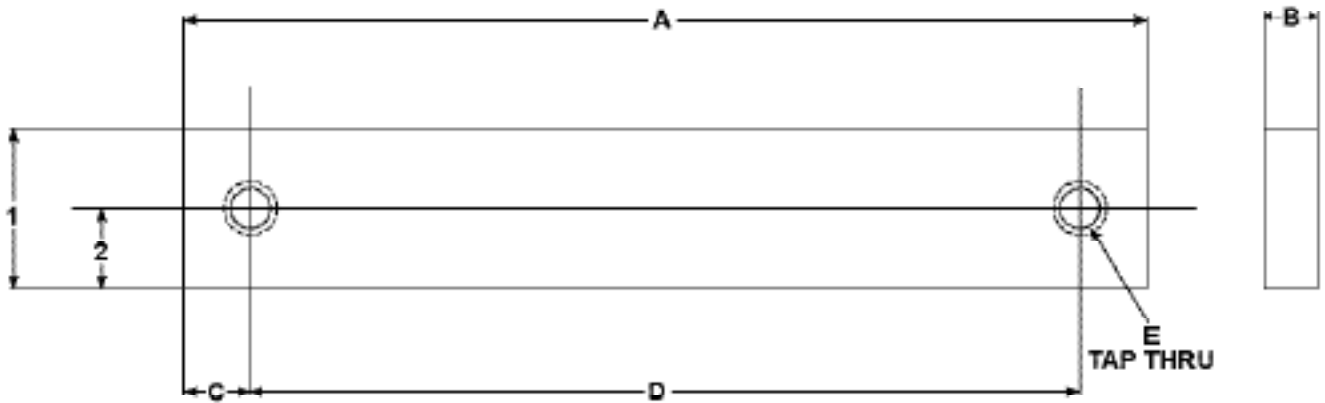

Figure 8. Recommended Assembly Stands



PUMP MODEL	BEARING SIZE	INCHES									
		A	B	C	D	E	F	G	H	J	K
40 & 75	205 — 25 × 52 mm	2.027	1.87	1.233	1.03	0.88	1 3/8	5/8	5	3.25	4.5
100/125	206 — 30 × 62 mm	2.42	2.272	1.423	1.226	0.942	1 1/2	13/16	5	3.25	4.5
200/300	207 — 35 × 72 mm	2.814	2.608	1.67	1.423	1.255	1 1/2	11/16	5	3.25	4.5
525	310 — 50 × 110 mm	4.31	3.937	2.375	2.01	1.755	2	11/16	5	3.25	4.5
950	1314 — 70 × 150 mm	5.885	5.25	3.5	2.8	2.255	2.75	1 1/8	11	9.25	10

Figure 9. Bearing Driver Tool



PUMP SIZE	MATERIAL	INCHES				
		A	B	C	D	E
KLRC-40	Cold Rolled Steel	14	1/2	1	12	3/8 × 16
KLRC-75/100		16	1/2	1 1/4	13 9/16	3/8 × 16
KLRC-125		18	1/2	1	15 15/16	3/8 × 16
KLRC-200		18	3/4	1 5/8	14 11/16	3/8 × 16
KLRC-300		21	3/4	1 3/16	18 5/8	3/8 × 16
KLRC-525		28	3/4	1 3/8	25 1/4	1/2 × 13
KLRC-950		37 3/8	1	1 3/16	35	5/8 × 11

Figure 10. Foot Alignment Tool



Figure 11. Cross Section KLRC-40 & KLRC-75

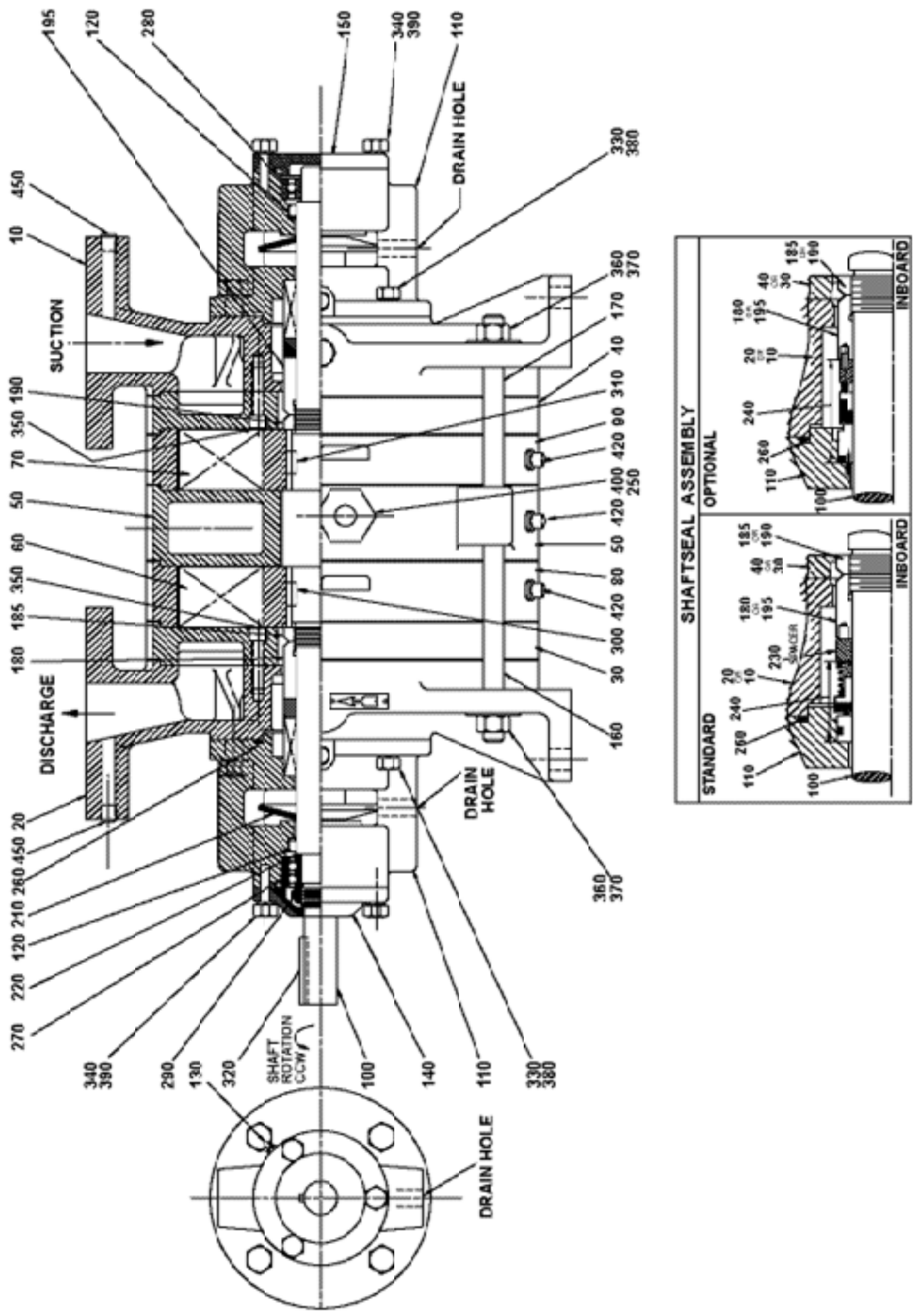

CAST IRON 40/75 KLRC ASSEMBLY PARTS LIST

ITEM #	DESCRIPTION	QTY
10	END CASING NDE	1
20	END CASING DE	1
30	END PLATE DE	1
40	END PLATE NDE	1
50	CTR HOUSING	1
60	IMPELLER DE	1
70	IMPELLER NDE	1
80	IMPELLER HSG DE	1
90	IMPELLER HSG NDE	1
100	SHAFT	1
110	BEARING HOUSING	2
120**	OIL SEAL	2
130**	GREASE FITTING	2
140	CAP, BRG HSG DE	1
150	CAP, BRG HSG NDE	1
160	TIE ROD DE	4
170	TIE ROD NDE	4
180	DE IMPELLER NUT (LH)	1
185	DE IMPELLER LOCK NUT (LH)	1
190	NDE IMPELLER NUT (RH)	1
195	NDE IMPELLER LOCK NUT (RH)	1
210	FLINGER	2
220	SPACER, BRG	1
230	SPACER, SHAFT SEAL	1
240**	SHAFT SEAL, LR	2
250*	ATTENUATION VALVE, 1/4 NPT	1
260**	O-RING, VITON	2
270**	BALL BRG, DOUBLE ROW	1
280**	BALL BRG, SINGLE ROW	1
290**	BRG, LOCKNUT	1
300	KEY, DE IMPELLER	1
310	KEY, NDE IMPELLER	1
320**	KEY, DRIVE SHAFT	1
330	HEX HD CAP SCR (BRG HSG)	8
340	HEX HD CAP SCR (BRG HSG CAP)	6
350**	HEX SOC CAP SCR (END PLATES)	4
360	HEX NUT (TIE RODS)	8
370	PLAIN WASHER (TIE RODS)	8
380	LOCKWASHER (BRG HSG)	8
390	LOCKWASHER (BRG HSG CAP)	6
400	HEX HD BSHG (ATTENUATION VALVE)	1
410*	PPG CTSK (CTR HSG)	2
420	PIPE PLUG, SQ (DRAIN)	3
430*	PIPE PLUG HEX SOC (DRAIN)	3
440*	PPG, HEXS (SHAFT SEALS)	2
460*	PPG, CTSK (DE END CASING)	1
* ITEMS NOT SHOWN ** RECOMMENDED SPARE PARTS		

Figure 12. Cross Section KLRC-40CD & KLRC-75CD (Stainless)

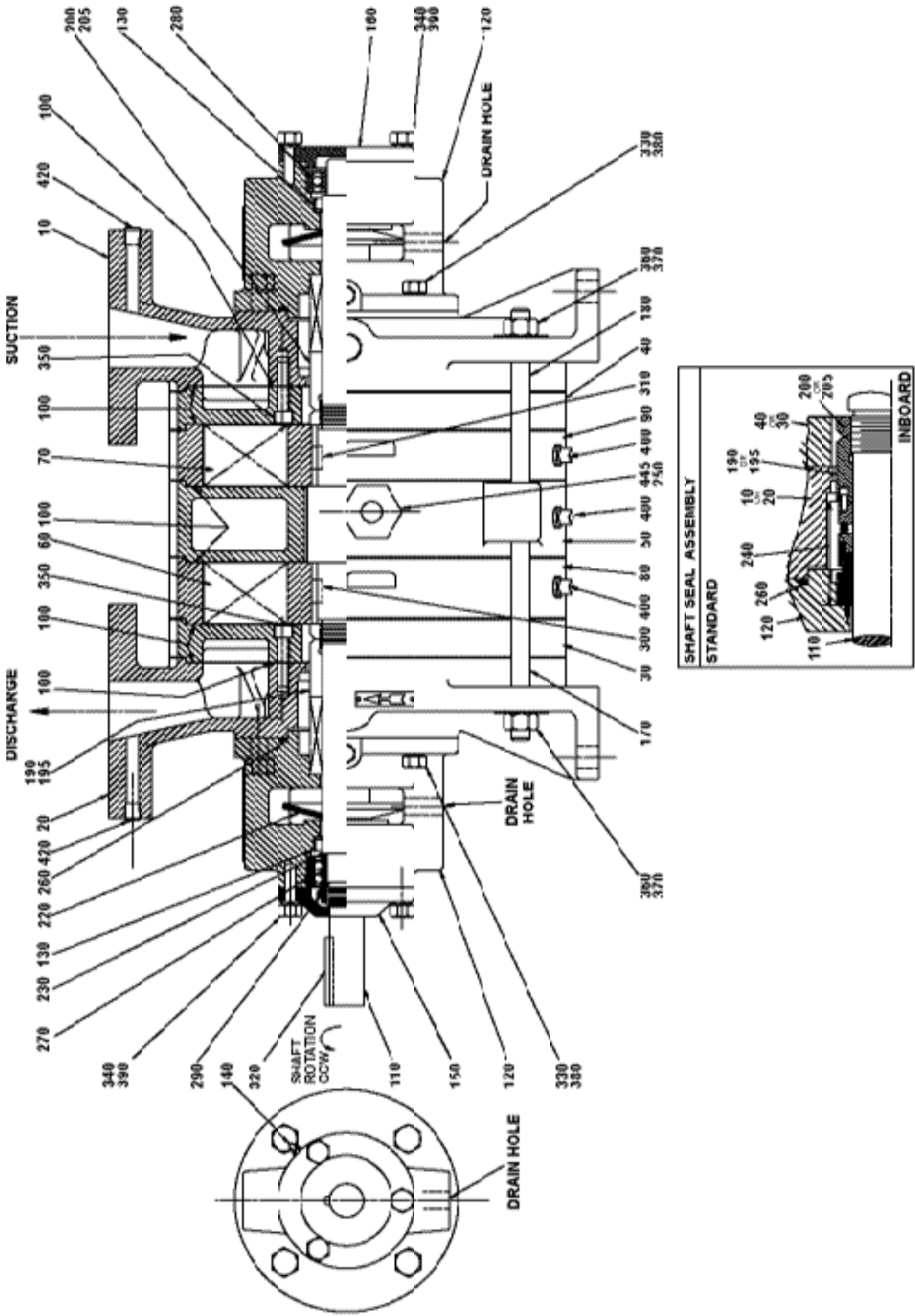



STAINLESS STEEL 40-75 KLRC GASKETED ASSEMBLY PARTS LIST

ITEM #	DESCRIPTION	QTY
10	END CASING NDE	1
20	END CASING DE	1
30	END PLATE DE	1
40	END PLATE NDE	1
50	CTR HOUSING GASKETED	1
60	IMPELLER DE	1
70	IMPELLER NDE	1
80	IMPELLER HSG GASKETED DE	1
90	IMPELLER HSG GASKETED NDE	1
100**	GASKET SET, .015" THICK PTFE	1
110	SHAFT	1
120	BEARING HOUSING	2
130**	OIL SEAL	2
140**	GREASE FITTING	2
150	CAP, BRG HSG DE	1
160	CAP, BRG HSG NDE	1
170	TIE ROD DE	4
180	TIE ROD NDE	4
190	DE IMPELLER NUT, (LH)	1
195	DE IMPELLER LOCK NUT, (LH)	1
200	NDE IMPELLER NUT, (RH)	1
205	NDE IMPELLER LOCK NUT, (RH)	1
220**	FLINGER	2
230	SPACER, BRG	1
240**	SHAFT SEAL, LR	2
250*	ATTENUATION VALVE, 1/4 NPT	1
260**	O-RING, VITON	2
270**	BALL BRG, DOUBLE ROW	1
280**	BALL BRG, SINGLE ROW	1
290**	BRG, LOCKNUT	1
300	KEY, DE IMPELLER	1
310	KEY, NDE IMPELLER	1
320**	KEY, DRIVE SHAFT	1
330	HEX HD CAP SCR (BRG HSG)	8
340	HEX HD CAP SCR (BRG HSG CAP)	6
350**	HEX SOC CAP SCR (ENDPLATES)	4
360	HEX NUT (TIE RODS)	8
370	PLAIN WASHER (TIE RODS)	8
380	LOCKWASHER (BRG HSG)	8
390	LOCKWASHER (BRG HSG CAP)	6
400	PIPE PLUG, SQ (DRAIN)	3
405	PPG CTSK (CTR HSG)	2
410	PPG HEX SOC (IMPELLER HOISINGS)	2
430	PPG HEX SOC (SHAFT SEALS)	2
440	PPG CTSK (DE END CASING)	1
445	HEX HD BSHG (ATTENUATION VALVE)	1

\* ITEMS NOT SHOWN    \*\* RECOMMENDED SPARE PARTS

Figure 13. Cross Section KLRC-100 to KLRC-525

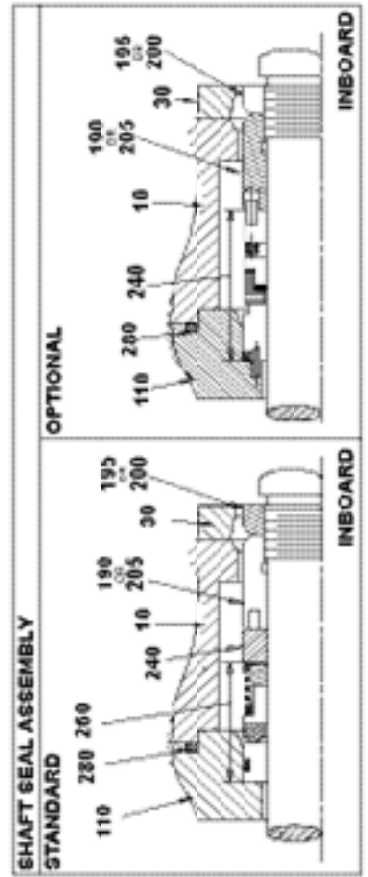
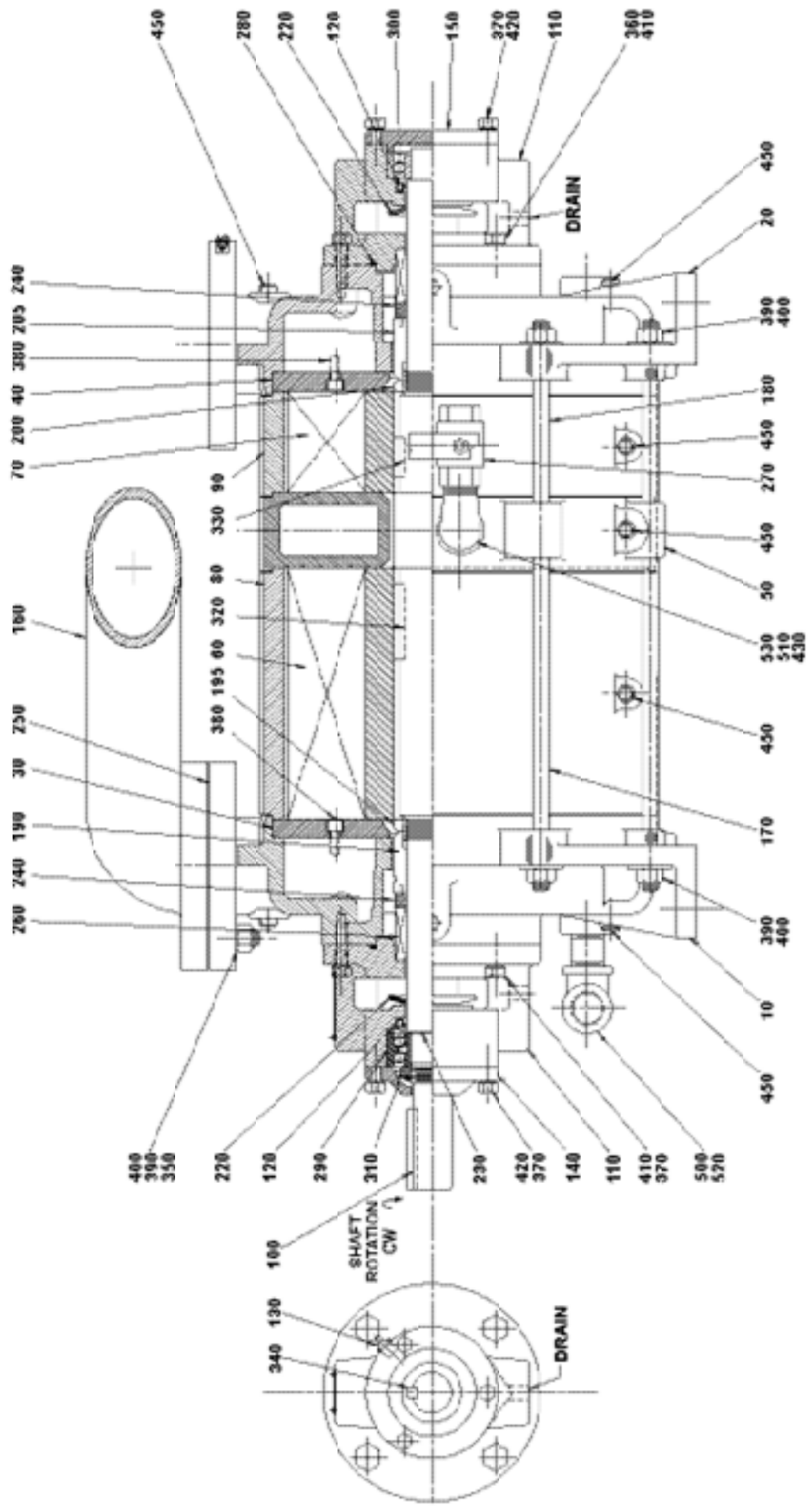

CAST IRON 100-525 KLRC ASSEMBLY PARTS LIST

ITEM #	DESCRIPTION	QTY
10	END CASING DE	1
20	END CASING NDE	1
30	END PLATE DE	1
40	END PLATE NDE	1
50	CTR HOUSING	1
60	IMPELLER, DE	1
70	IMPELLER, NDE	1
80	IMPELLER HSG DE	1
90	IMPELLER HSG NDE	1
100	SHAFT (LH THR'D)	1
110	BRG HSG, GRSBL BRG	2
120**	OIL SEAL, (BRG HSG)	2
130**	GREASE FITTING, (BRG HSG)	2
140	CAP, END DE GRSBL	1
150	CAP, END GRSBL NDE	1
160	CROSSOVER PIPE	1
170	TIE ROD DE	8
180	TIE ROD NDE	8
190	IMP LK NUT, LH THD	1
195	IMP NUT, LH THD	1
200	IMP LK NUT, RH THD	1
205	IMP NUT, RH THD	1
220	FLINGER	2
230	SPACER, BRG	2
240	SPACER, SHAFT SEAL	2
250**	GASKET, FLANGE (CROSSOVER)	2
260**	SHAFT SEAL, LR	2
270	ATTENUATION VALVE	1
280**	O-RING (BRG, HSG)	2
290**	BRG, DOUBLE ROW ANGULAR CONTACT	1
300**	BRG, SINGLE ROW CONRAD	1
310**	BRG, LOCKNUT	1
320	KEY, DE IMPELLER	1
330	KEY, NDE IMPELLER	1
340**	KEY, DRIVE SHAFT	1
350	STUD, CROSSOVER	8
360	HEX HD CAP SCR (BRG HSG)	8
370	HEX HD CAP SCR (BRG HSG CAP)	6
380**	HEX SOC CAP SCR (END PLATES)	4
390	HEX NUT (TIE RODS & CROSSOVER)	24
400	PLAIN WASHER (TIE RODS & CROSSOVER)	24
410	LOCKWASHER (BRG HSG)	8
420	LOCKWASHER (BRG HSG CAP)	6
430	HHBSHG (ATTENUATION)	1
440*	PPG CTSK (CTR HSG)	2
480*	PPG, HEXS (VACUUM RELIEF VALVE)	1
500	PIPE NIPPLE(SEALANT INLET)	1
510	PIPE NIPPLE (ATTENUATION)	1
520	ELB 90° (SEALANT INLET)	1
530	ELB 90° (ATTENUATION)	1
* ITEMS NOT SHOWN ** RECOMMENDED SPARE PARTS		



STAINLESS STEEL 100-525 KLRC GASKETED ASSEMBLY PARTS LIST

ITEM #	DESCRIPTION	QTY
10	END CASING DE	1
20	END CASING NDE	1
30	END PLATE DE	1
40	END PLATE NDE	1
50	CTR HOUSING	1
60	IMP. DE	1
70	IMP. NDE	1
80	IMPELLER HSG DE	1
90	IMPELLER HSG NDE	1
100**	GASKET SET	1
110	SHAFT (LH THR'D)	1
120	BRG HSG, GRSBL BRG	2
130**	OIL SEAL, (BRG HSG)	2
140**	GREASE FITTING, (BRG HSG)	2
150	CAP, END DE GRSBL	1
160	CAP, END GRSBL NDE	1
170	CROSSOVER PIPE	1
180	TIE ROD DE	8
190	TIE ROD NDE	8
200	IMP LK NUT, LH THD	1
205	IMP NUT, LH THD	1
210	IMP LK NUT, RH THD	1
215	IMP NUT, RH THD	1
230**	FLINGER	2
240	SPACER, BRG	1
250**	GASKET, FLANGE (CROSSOVER)	2
260**	SHAFT SEAL, LR	1
270	ATTENUATION VALVE	1
280**	O-RING, (BRG HSG)	2
290**	BRG, DOUBLE ROW ANGULAR CONTACT	1
300**	BRG, SINGLE ROW CONRAD	1
310**	BRG, LOCKNUT	1
320	KEY, DE IMPELLER	1
330	KEY, NDE IMPELLER	1
340**	KEY, DRIVE SHAFT	1
350	STUD, CROSSOVER	8
360	HEX HD CAP SCR (BRG HSG)	8
370	HEX HD CAP SCR (BRG HSG CAP)	6
380**	HEX SOC CAP SCR (END PLATES)	4
390	HEX NUT (TIE RODS & CROSSOVR)	24
400	PLAIN WASHER (TIE RODS)	24
410	LOCKWASHER (BRG HSG)	8
420	LOCKWASHER (BRG HSG CAP)	6
450	PIPE PLUG HEX SOC (DRAINS)	15
460*	PPG, HEXS (VACUUM RELIEF VALVE)	1
470*	PPG CTSK (CTR HSG)	2
480	PIPE NIPPLE (SEALANT INLET)	1
490*	PIPE NIPPLE (ATTENUATION)	1
500	ELB 90° (SEALANT INLET)	1
510	ELB 90° STREET (ATTENUATION)	1
515*	HHBSHG (ATTENUATION)	1
* ITEMS NOT SHOWN ** RECOMMENDED SPARE PARTS		

Figure 15. Cross Section KLRC-950

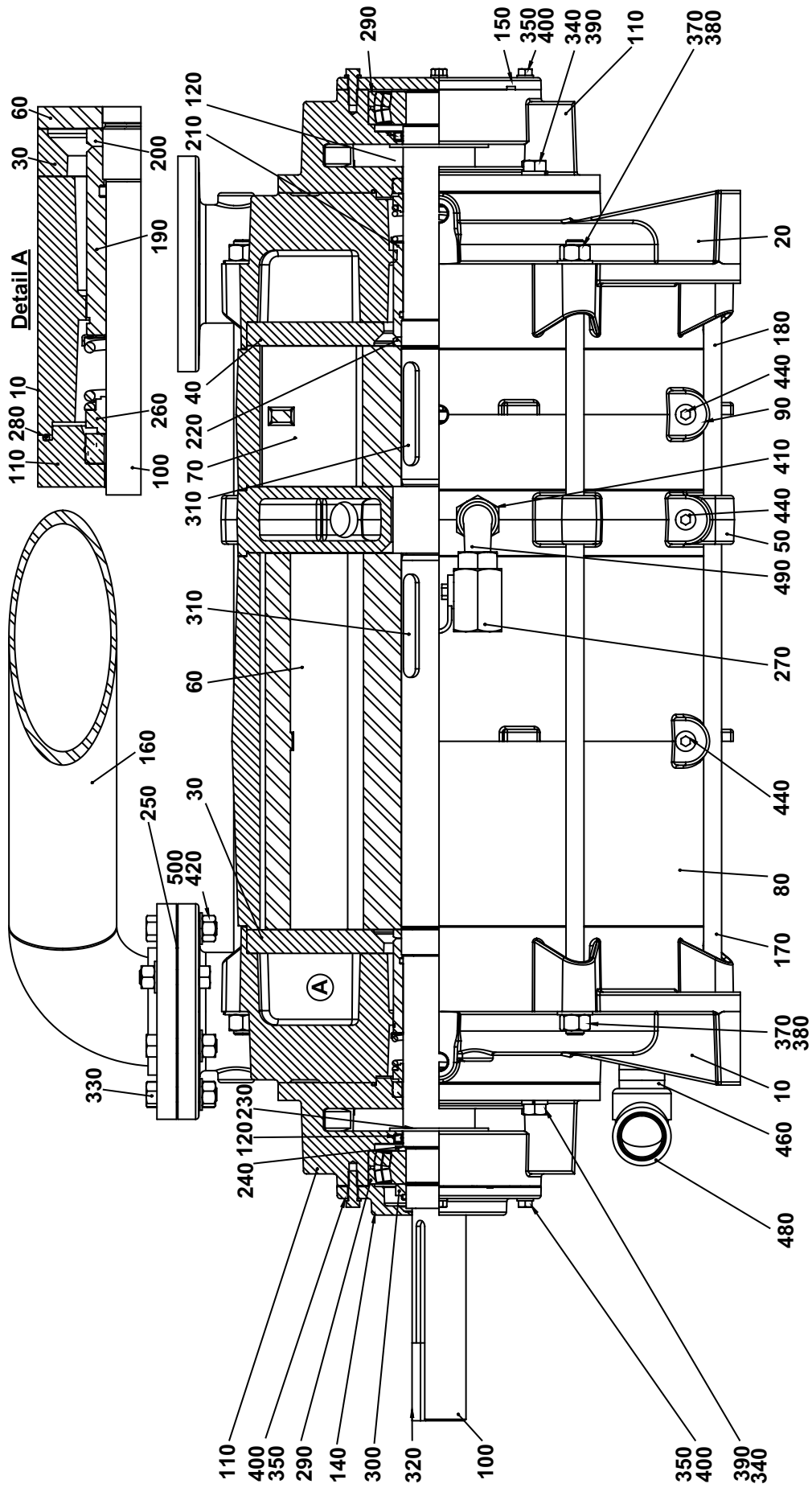

950 KLRC ASSEMBLY PARTS LIST

ITEM #	DESCRIPTION	QTY
10	END CASING, DE	1
20	END CASING, NDE	1
30	ENDPLATE, DE	1
40	ENDPLATE, NDE	1
50	CENTER HOUSING	1
60	IMPELLER, DE	1
70	IMPELLER, NDE	1
80	IMPELLER HOUSING, DE	1
90	IMPELLER HOUSING, NDE	1
100	SHAFT	1
110	BEARING HOUSING	2
120	LIP SEAL	2
130*	GREASE FITTING	2
140	END CAP, DE	1
150	END CAP, NDE	1
160	CROSSOVER PIPE	1
170	TIE ROD, DE	8
180	TIE ROD, NDE	8
190	IMPELLER LOCK NUT-LH,M80X1.5	1
200	IMPELLER NUT-LH,M80X1.5	1
210	IMPELLER LOCK NUT-RH,M80X1.5	1
220	IMP NUT, RH THD	1
230	FLINGER	2
240	BEARING SPACER	1
250	4" RING GASKET	2
260	MECHANICAL SEAL	2
270	BALL VALVE, .75"	1
280	O-RING	2
290	BEARING	2
300	BEARING LOCKNUT	1
310	IMPELLER KEY	2
320	SQUARE KEY .5" X 3.25"	1
330	HEXBOLT .625-11 X 2.5	16
340	HEXBOLT .625-11 X 2	8
350	HEXBOLT .375-16 X 1.25	8
360*	HEX SOCK CAPSCREW .375"-16 X 1	2
370	HEXNUT .75"	16
380	FLATWASHER .75"	16
390	LOCKWASHER .625"	8
400	LOCKWASHER .375"	8
410	HEX REDUCING BUSHING	1
420	FLATWASHER .625"	16
430*	PIPE PLUG, SQUARE SOCK 1.25"	2
440	PIPE PLUG, HEX SOCK .5"	12
450*	PIPE PLUG, SQUARE SOCK 1.5"	1
460	NIPPLE 1.5"	1
470*	NIPPLE, 75"	1
480	ELBOW, 1.50" NPT	1
490	STREET ELBOW	1
500	HEXNUT .625"	16

\* ITEMS NOT SHOWN







## WARRANTY – VACUUM PRODUCTS

Subject to the terms and conditions hereinafter set forth and set forth in General Terms of Sale, Tuthill Vacuum & Blower Systems (the seller) warrants products and parts of its manufacture, when shipped, and its work (including installation and start-up) when performed, will be of good quality and will be free from defects in material and workmanship. This warranty applies only to Seller's equipment, under use and service in accordance with seller's written instructions, recommendations and ratings for installation, operating, maintenance and service of products, for a period as stated in the table below. Because of varying conditions of installation and operation, all guarantees of performance are subject to plus or minus 5% variation. (Non-standard materials are subject to a plus or minus 10% variation).

PRODUCT TYPE	WARRANTY DURATION
New	15 months after date of shipment or 12 months after initial startup date, whichever occurs first
Repair	6 months after date of shipment or remaining warranty period, whichever is greater
Remanufactured	9 months after date of shipment or 6 months after initial startup date, whichever occurs first

THIS WARRANTY EXTENDS ONLY TO BUYER AND/OR ORIGINAL END USER, AND IN NO EVENT SHALL THE SELLER BE LIABLE FOR PROPERTY DAMAGE SUSTAINED BY A PERSON DESIGNATED BY THE LAW OF ANY JURISDICTION AS A THIRD PARTY BENEFICIARY OF THIS WARRANTY OR ANY OTHER WARRANTY HELD TO SURVIVE SELLER'S DISCLAIMER.

All accessories furnished by Seller but manufactured by others bear only that manufacturer's standard warranty.

All claims for defective products, parts, or work under this warranty must be made in writing immediately upon discovery and, in any event within one (1) year from date of shipment of the applicable item and all claims for defective work must be made in writing immediately upon discovery and in any event within one (1) year from date of completion thereof by Seller. Unless done with prior written consent of Seller, any repairs, alterations or disassembly of Seller's equipment shall void warranty. Installation and transportation costs are not included and defective items must be held for Seller's inspection and returned to Seller's Ex-works point upon request.

THERE ARE NO WARRANTIES, EXPRESSED, IMPLIED OR STATUTORY WHICH EXTEND BEYOND THE DESCRIPTION ON THE FACE HEREOF, INCLUDING WITHOUT LIMITATION, THE IMPLIED WARRANTIES OF MERCHANTABILITY AND FITNESS OF PURPOSE.

After Buyer's submission of a claim as provided above and its approval, Seller shall at its option either repair or replace its product, part, or work at the original Ex-works point of shipment, or refund an equitable portion of the purchase price.

The products and parts sold hereunder are not warranted for operation with erosive or corrosive material or those which may lead to build up of material within the product supplied, nor those which are incompatible with the materials of construction. The Buyer shall have no claim whatsoever and no product or part shall be deemed to be defective by reason of failure to resist erosive or corrosive action nor for problems resulting from build-up of material within the unit nor for problems due to incompatibility with the materials of construction.

Any improper use, operation beyond capacity, substitution of parts not approved by Seller, or any alteration or repair by others in such manner as in Seller's judgment affects the product materially and adversely shall void this warranty.

No employee or representative of Seller other than an Officer of the Company is authorized to change this warranty in any way or grant any other warranty. Any such change by an Officer of the Company must be in writing.

The foregoing is Seller's only obligation and Buyer's only remedy for breach of warranty, and except for gross negligence, willful misconduct and remedies permitted under the General Terms of Sale in the sections on CONTRACT PERFORMANCE, INSPECTION AND ACCEPTANCE and the PATENTS Clause hereof, the foregoing is BUYER'S ONLY REMEDY HEREUNDER BY WAY OF BREACH OF CONTRACT, TORT OR OTHERWISE, WITHOUT REGARD TO WHETHER ANY DEFECT WAS DISCOVERED OR LATENT AT THE TIME OF DELIVERY OF THE PRODUCT OR WORK. In no event shall Buyer be entitled to incidental or consequential damages. Any action for breach of this agreement must commence within one (1) year after the cause of action has occurred.

January, 2002

## OPERATING DATA

It is to the user's advantage to have the requested data filled in below and available in the event a problem should develop in the vacuum pump or the system. This information is also helpful when ordering spare parts.

Model No. \_\_\_\_\_ V-Belt Size: \_\_\_\_\_ Length: \_\_\_\_\_

Serial No. \_\_\_\_\_ Type of Lubrication: \_\_\_\_\_

Startup Date \_\_\_\_\_

Pump RPM \_\_\_\_\_ Operating Vacuum \_\_\_\_\_

Pump Sheave Diameter: \_\_\_\_\_ Any other special accessories supplied or in use: \_\_\_\_\_

Motor Sheave Diameter: \_\_\_\_\_

Motor RPM \_\_\_\_\_ HP \_\_\_\_\_

NOTES: \_\_\_\_\_

\_\_\_\_\_  
\_\_\_\_\_  
\_\_\_\_\_  
\_\_\_\_\_  
\_\_\_\_\_

## IMPORTANT

All vacuum pumps manufactured by Tuthill Vacuum & Blower Systems are date coded at time of shipment. In order to assure you of the full benefits of the product warranty, please complete, tear out and return the product registration card below, or you can visit our product registration web page at:

[http://vacuum.tuthill.com/product\\_registration](http://vacuum.tuthill.com/product_registration)

**IMPORTANT**

All vacuum pumps manufactured by Tuthill Vacuum & Blower Systems are date coded at time of shipment. In order to assure you of the full benefits of the product warranty, please complete, tear out and return this product registration card.

Company \_\_\_\_\_

Location \_\_\_\_\_  
City/State/Province      ZIP/Postal Code      Country

Telephone : (    ) \_\_\_\_\_

E-mail: \_\_\_\_\_

Model: \_\_\_\_\_

Serial Number: \_\_\_\_\_

Date of Purchase: \_\_\_\_\_

Date of Startup: \_\_\_\_\_

PLEASE CHECK ONE

Vacuum Furnace     

Vacuum Coating     

Pharmaceutical     

Semiconductor/Electronics     

Food/Meat Packing     

Gas/Petrochemical     

Other \_\_\_\_\_



NO POSTAGE  
NECESSARY  
IF MAILED  
IN THE  
UNITED STATES

**BUSINESS REPLY MAIL**

FIRST-CLASS MAIL PERMIT NO. 2912 SPRINGFIELD MO

POSTAGE WILL BE PAID BY ADDRESSEE

ATTN. CUSTOMER SERVICE – VACUUM PRODUCTS  
TUTHILL VACUUM & BLOWER SYSTEMS  
PO BOX 2877  
SPRINGFIELD MO 65890-2150

