

FEDERAL STATE UNITARY ENTERPRISE  
PRODUCTION AMALGAMATION  
"NOVOSIBIRSK INSTRUMENT-MAKING PLANT"



**OPTICAL SIGHTS**  
**PO6×36, PO6×36-1, PO6×36-2**

Service manual  
AL3.812.225 RE



## **CONTENTS**

	Page
1 Purpose	5
2 Specifications	6
3 Nomenclature list	6
4 Preparation for use	6
5 Operation	10
6 Maintenance and storage	13
7 Safety	13
8 Acceptance certificate	14

**The sights are the subject of continuous development and improvement, consequently there may be slight differences between the product and the information given herein.**

The service manual of the sights is intended for studying operating rules, contains specifications, information about operation with the sights as well as the main rules, necessary to ensure operation and full use of technical opportunities.

## **1 PURPOSE**

The Optical Sights PO6×36, PO6×36-1, PO6×36-2 (hereafter referred to as the sight) are designed to be mounted on a hunting weapon. The sight PO6×36 is mounted on the weapon type "Tigr", the sight PO6×36-1 is mounted on the weapon type "Saiga", the sight PO6×36-2 is mounted on the weapon type "Vepr".

The sight features reticle illumination, allowing for use under twilight conditions.

The sights are provided with two handwheels with scales which make it possible to input the required windage and elevation corrections during adjustment of fire and shooting.

The sights are designed to operate in an open air environment within a temperature range of -40 °C to +40 °C and relative humidity up to 95% at temperature + 25 °C.

## 2 SPECIFICATIONS

Magnification, x	6
Angular field of view	4 °
Resolution limit, sec	12
Exit pupil diameter, mm	6
Eye relief, mm	66
Diopter setting of the eyepiece, D	from - 0,5 to - 1
Overall dimensions, mm	410×136/151×72
Weight, kg, not more	0,74

## 3 NOMENCLATURE LIST

Sight	1
Wrench	1
Eyeshade	1 separated from the sight
Box	1
Service manual	1

## 4 PREPARATION FOR USE

Mount the sight on a weapon and make an adjustment before use.

Prior mounting the sight on the weapon place an eyeshade.

The sight is mounted on the weapon with the help of a special mount. Turn the mount latch 5 (fig.1) aside up to the stop prior installing the sight on the

weapon, place the mount rail dovetail type on the weapon slot and shift the sight ahead till home, and secure it by turning the latch 5 forward – for the sight PO6×36; backward – for the sights PO6×36-1, PO6×36-2 up to the complete fixation. The sight must be securely fastened onto the weapon. If the sight sways or the latch 5 does not shut when the sight is fastened, it is necessary to adjust the mount clamp of the sight in the following way:

- take the sight off a weapon;
- push the slider 6 in the bottom part of the mount until pressing of the spring 8;
- turn the nut 7 on 1-2 teeth counter-clockwise or clockwise;
- check the placing of the sight on the weapon and repeat the adjustment if necessary.

The sight on the weapon should be adjusted after ranging with opened sight (foresight and sighting). For this purpose it is necessary to perform the following:

- fastened the sight onto the weapon;
- place the upper handwheel 1 of the sight on the point "1", the side handwheel 1 (fig. 2) – on the point "0";
- align the weapon by the opened sight placed on the point "1" at a target at a distant of 100 m;

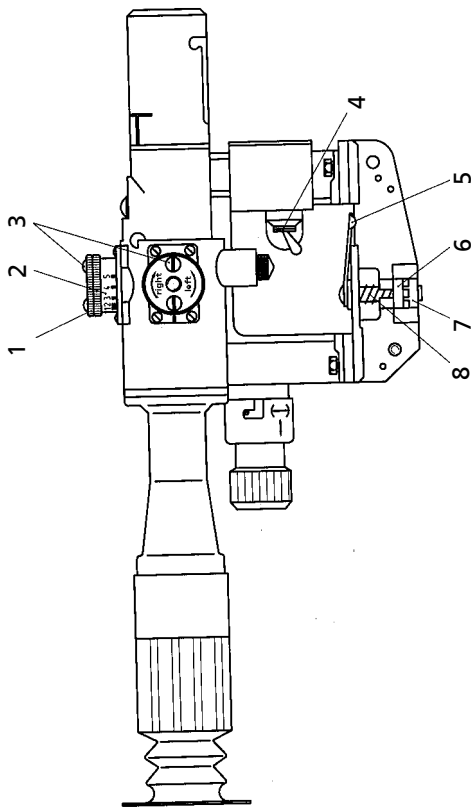

1 – upper handwheel; 2 – scale of vertical angles; 3 – screw;  
 4 – tumbler; 5 – mount latch; 6 – slider; 7 – nut; 8 – spring

**Figure 1 – The sight PO6x36 (right-side view)**



- look through the eyepiece of the sight, notice the aiming sign position;
- if the aiming sign coincides with the aiming point of the opened sight, the sight is adjusted;
- otherwise, untighten the screws 3 (fig. 1) performing 1-2 turns on the upper and side handwheels in accordance with figures 1, 2, and coincide the aiming sign with the aiming point of

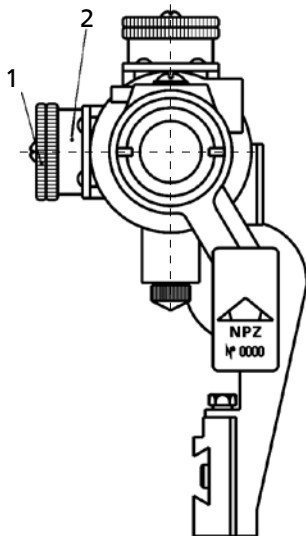

- 1 – side handwheel ;
- 2 – scale of windage adjustments

Figure 2 – **The Sight PO6×36**  
**(objective side view)**

the opened sight by turning these handwheels (scale 2, figure 1 and scale 2, figure 2 must be kept in initial position);

– carefully tighten the screws 3 (fig.1) of handwheels up to the stop and reassess the coincidence of aiming sign with aiming point of the opened sight. Repeat the adjustment if necessary.

## **5 OPERATION**

The upper handwheel adjustment must be determined by testing according to the type of the weapon and a firing distance.

The turn of the upper handwheel on one click shifts the point of hit up (down) on 3,2 cm for each 100 m.

The turn of the side handwheel on one click shifts the point of hit right (left) on 3,2 cm for each 100 m.

The sight can be completed with a one of the three reticles according to figures 3, 4, 5 – *Field of view*.

The distance to the target can be determined by using of range scale of the sight reticle according to figure 4.

To determine the distance according to range scale of the reticle by the height of a target of 1,5 m, aim the scale to the target so that the target is placed between the continuous horizontal and dotted curve lines. Scale stroke above the target indicates the distance to the target.

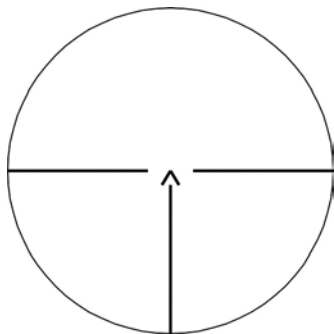

Figure 3 – **Field of view**

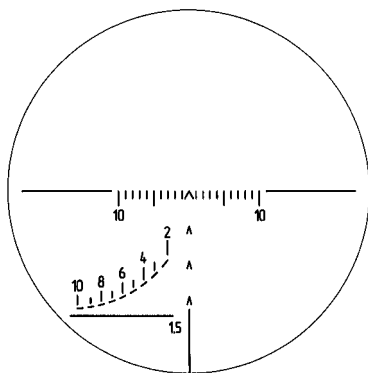

Figure 4 – **Field of view**

The distance to the target can be determined by using of range scale of the sight reticle and designed for the target of 1.5 m length in accordance to figure 5.

To determine the distance to a target of 1,5 m length, combine target image with vertical strokes of the range scale. The number, which is located near the point of contact, will indicate the distance to the target in hundreds of meters.

The sights are equipped with the reticle illumination for aiming under twilight conditions, illumination switches with the "On-Off" tumbler 4 (fig.1). A battery type A-316 with the voltage of 1,5 V is used as a power source for illumination. The strokes of the reticle are in red color when the reticule illumination is switched on.

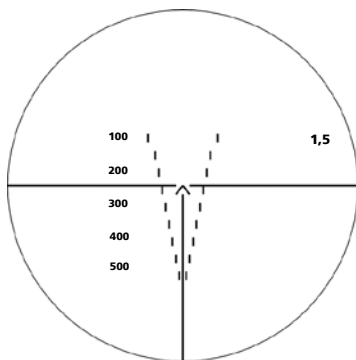

Figure 5 – **Field of view**

## **6 MAINTENANCE AND STORAGE**

Protect the sights from physical damage.

Wipe the outer optical surfaces with a clean, soft cotton fabric, remove oil spots and thin coats with the cotton wool wet with alcohol.

Protect optical parts of the sight from the scratches during storage and operation.

## **7 SAFETY**

During the operation with the sight, insure the mounting is securely attached to the weapon. If the sight sways, it is necessary to adjust the clamp of a mount as indicated in the part 4.

## **8 ACCEPTANCE CERTIFICATE**

The Sight PO6×36\_\_\_\_, serial № \_\_\_\_\_,  
is manufactured in accordance with technical  
documentation and is fit for operation.

Date of issue \_\_\_\_\_

Signatures \_\_\_\_\_  
(stamp)

Federal State Unitary Enterprise  
Production Amalgamation  
“Novosibirsk Instrument-Making Plant”,  
179/2, D.Kovalchuk,  
Novosibirsk, 630049  
Russia