

HUSSMANN® *Excel*



Rear Roll-in Dairy ***Medium Temperature Free Standing or Suspended*** ***Merchandisers Installed in Walk-in Cooler Exterior Walls***



Installation & ***Service Manual*** Shipped With Case Data Sheets

IMPORTANT

**Keep in store for
future reference!**

P/N 0485219_B
Excel Series
July 2014

Spanish 0532258
French 0532259

TABLE OF CONTENTS

INSTALLATION

NSF Certification	1-1
Model Description	1-1
Location	1-1
Shipping Damage	1-1
Exterior Loading	1-2
Merchandiser Ends	1-2
Shipping Braces	1-2
Leveling	1-2
Installing D5XRRIS	1-3
Installing D5XRRI	1-5
Rear Curtain Installation	1-5
Joining Instructions	1-5
Installing Partitions	1-5

REFRIGERATION / ELECTRICAL

Refrigerant	2-1
Refrigerant Piping	2-1
Insulation	2-2
Suction Line	2-2
Liquid Line	2-2
Refrigeration Thermostat	2-3
Defrost Termination	2-3
Defrost Sequences	2-3
Merchandiser Electrical Data	2-4
Electrical Connections	2-4
Field Wiring	2-4
Identification of Wiring	2-4
Wiring Color Code	2-4

DRIP PIPING AND SPLASHGUARDS

Waste Outlet	3-1
Installing Drip Piping	3-1
Sealing Splashguard to Floor	3-1

START UP / OPERATION

Start up	4-1
Stocking	4-1
Optional Shelving	4-1
Accessories	4-2
Load Limits	4-2
Installing FDA/NSF Thermometer	4-2

MAINTENANCE

Care and Cleaning	5-1
Cleaning Honeycomb Assemblies	5-2
Removing Return Air Grille	5-3
Removing Scratches from Bumper	5-4

SERVICE

Replacing Fan Motors and Blades	6-1
Replacing Fluorescent Lamps	6-2
Replacing Lamp Holders and End Caps ..	6-2
Replacing Ballasts	6-3
Repairing Aluminum Coils	6-4

WARRANTY

IMPORTANT
KEEP IN STORE FOR FUTURE REFERENCE
Quality that sets industry standards!

12999 St. Charles Rock Road • Bridgeton, MO 63044-2483

U.S. & Canada 1-800-922-1919 • Mexico 1-800-522-1900

www.hussmann.com

© 2014 Hussmann Corporation

REVISION HISTORY

REVISION B

- 1. Added Proposition 65 Warning Statement

REVISION A

- 1. Revised to Excel, page 1-2, 1-3, 1-4, 2-1, 2-3, 3-1, 3-2, 4-2, 5-2.

REVISION HISTORY — Original Issue

ANSI Z535.5 DEFINITIONS



• **DANGER** – Indicate[s] a hazardous situation which, if not avoided, will result in death or serious injury.



• **WARNING** – Indicate[s] a hazardous situation which, if not avoided, could result in death or serious injury.



• **CAUTION** – Indicate[s] a hazardous situation which, if not avoided, could result in minor or moderate injury.

• **NOTICE** – *Not related to personal injury* – Indicates[s] situations, which if not avoided, could result in damage to equipment.

INSTALLATION

NSF CERTIFICATION

These merchandisers are manufactured to meet ANSI / National Sanitation Foundation (NSF®) Standard #7 requirements. Proper installation is required to maintain certification. Near the serial plate, each case carries a label identifying the type of application for which the merchandiser was certified.

**ANSI/NSF-7 Type I – Display Refrigerator / Freezer
Intended for 75°F / 55%RH Ambient Application**

**ANSI/NSF-7 Type II – Display Refrigerator / Freezer
Intended for 80°F / 55%RH Ambient Application**

**ANSI/NSF-7 – Display Refrigerator
Intended for Bulk Produce**

MODEL DESCRIPTION

The D5XRRI and D5XRRIS models are designed for installation against an opening in the cooler wall. The merchandisers are open at the rear. Once installed, product can be rolled directly from the cooler through the rear of the merchandiser into the refrigerated display area.

The D5XRRI is a self-supporting model with the canopy and front sections connected by welded end supports.

The D5XRRIS is manufactured in two sections: a Coil Package and a Front Package. The coil package is to be suspended against the cooler wall, above the opening, from an adequate supporting structure in the store. The front package completes the D5XRRIS model once it has been aligned with the coil package and anchored to the floor.

WARNING

Do not store items or flammable materials on top of the case.

LOCATION

These merchandisers are designed for displaying products in air conditioned stores where temperature is maintained at or below the ANSI/NSF-7 specified level and relative humidity is maintained at or below 55%.

Like other merchandisers, these are sensitive to air disturbances. Air currents passing around cases will seriously impair their operation. Do NOT allow air conditioning, electric fans, open doors or windows, etc. to create air currents around the merchandisers.

Product should always be maintained at proper temperature. This means that from the time the product is received, through storage, preparation and display, the temperature of the product must be controlled to maximize the life of the product.

For California Businesses:

WARNING

This product may contain chemicals known to the State of California to cause cancer, birth defects, or other reproductive harm.

This warning is the result of the California State law known as the California Safe Drinking Water and Toxic Enforcement Act of 1986, which is commonly referred to as “Proposition 65.”

This warning does not mean that Hussmann products will cause cancer or reproductive harm, or is in violation of any product-safety standards or requirements. As clarified by the California State government, Proposition 65 can be considered more of a ‘right to know’ law than a pure product safety law. When used as designed, Hussmann believes that our products are not harmful. We provide the Proposition 65 warning to stay in compliance with California State law. It is your responsibility to provide accurate Proposition 65 warning labels to your customers when necessary. For more information on Proposition 65, please visit the California State government website.

SHIPPING DAMAGE

All equipment should be thoroughly examined for shipping damage before and during unloading.

This equipment has been carefully inspected at our factory. Any claim for loss or damage must be made to the carrier. The carrier will provide any necessary inspection reports and/or claim forms.

Apparent Loss Or Damage

If there is an obvious loss or damage, it must be noted on the freight bill or express receipt and signed by the carrier's agent; otherwise, carrier may refuse claim.

Concealed Loss Or Damage

When loss or damage is not apparent until after equipment is uncrated, retain all packing materials and submit a written request to the carrier for inspection, within 15 days.



WARNING

Do NOT remove shipping braces until the merchandisers are positioned for installation. Once unfastened, NEVER LEAVE THE MERCHANDISER UNSUPPORTED OR UNATTENDED until it has been anchored.

EXTERIOR LOADING

Do NOT walk on top of merchandisers or damage to the merchandisers and serious personal injury could occur. THEY ARE NOT STRUCTURALLY DESIGNED TO SUPPORT EXCESSIVE EXTERNAL LOADING such as the weight of a person. Do not place heavy objects on the case.

MERCHANDISER ENDS

Ends for the D5XRRI and D5XRRIS rear load dairy models are shipped separately to be field installed after the merchandisers are installed in the cooler wall. Refer to separate instructions shipped with the ends.

SHIPPING BRACES

Move the merchandiser as close as possible to its permanent location and then remove all packaging. Check for damage before discarding packaging. Remove all separately packed accessories such as kits and shelves.

The D5XRRI is top-heavy and must be supported and moved with care at all times until it has been securely anchored. It must be supported while it is being unfastened from the skid and when it is removed from the skid. Once the skid has been unfastened, never leave the merchandiser unsupported or unattended until it has been anchored.

LEVELING

Merchandisers must be installed level to ensure proper operation of the refrigeration system and to ensure proper drainage of defrost water. When leveling merchandisers, use a carpenter's level as shown. Leveling shims are provided with each merchandiser for use if needed. The shims are long enough to allow leveling of adjoining merchandisers at the same time using only one shim.

NOTES:

- BEGIN LINEUP LEVELING FROM THE HIGHEST POINT OF THE STORE FLOOR.
- If shimming two corners, check to see if a shim is needed in the center of the case. If a gap exists between the support rail of the case and the floor, a shim should be placed in the center.

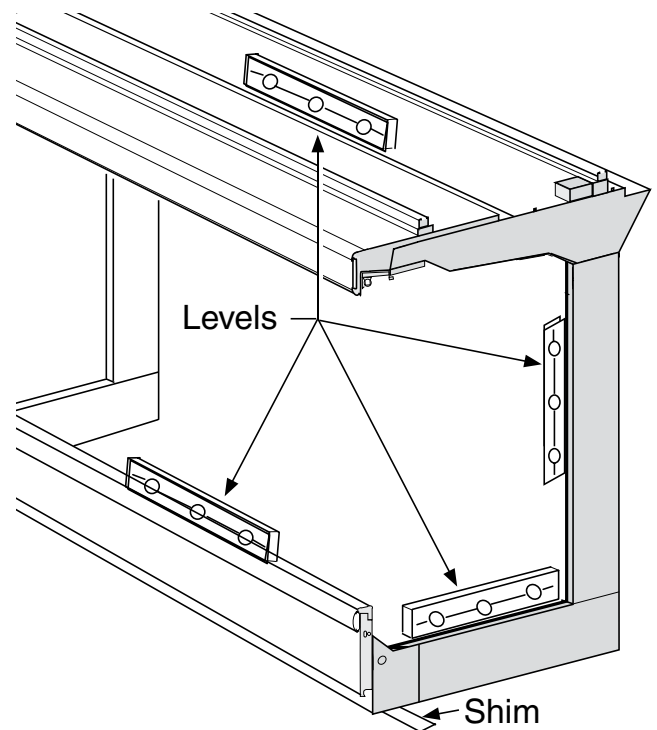

INSTALLING D5XRRIS

Overview

The coil package must be suspended above the cooler wall opening from an adequate support structure. It is imperative that both the method and the materials used to suspend the coil package be of sufficient strength to support the coil package.

Hanging Support Spacing

Case Length ft (mm)	Coil Package Weight lb (kg)	Minimum Number of 1/2 in. dia. (12.7 mm) Threaded Drop Rods Required
8 (2438)	485 (220)	4
12 (3658)	750 (340)	6

These models are designed for use with roll-in carts or free-standing (unattached) shelving.

DISCLAIMER: These methods of securing the coil package are suggestions only. It is the responsibility of the store designer, installer and end user to ensure the store's structural capacity. Hussmann assumes no liability for consequences resulting from failure of store structure or material used in installation.

Two 1⁵/₈ x 1⁵/₈ inch (41 x 41 mm) channel struts are provided for hanging the coil package. These struts extend the full length of the case and are bolted to the case at the factory. Use 1/2 in. (12.7 mm) clamp nuts to secure the hanging rods to the struts. Although these struts allow flexibility in hanging rod location, the end support rods must be within 12 in. (305 mm) of the coil package end. For a 12 ft (3658 mm) coil package, the center hanging rods must be within 12 in. (305 mm) of the center of the merchandiser.

Cantilevered "I" Beam

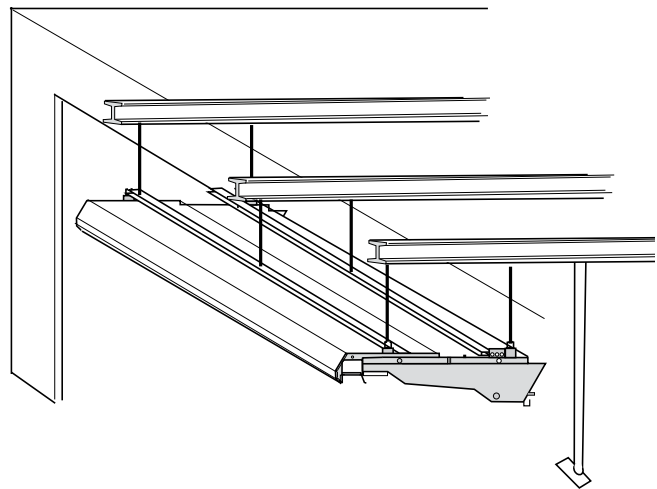

Store Joist

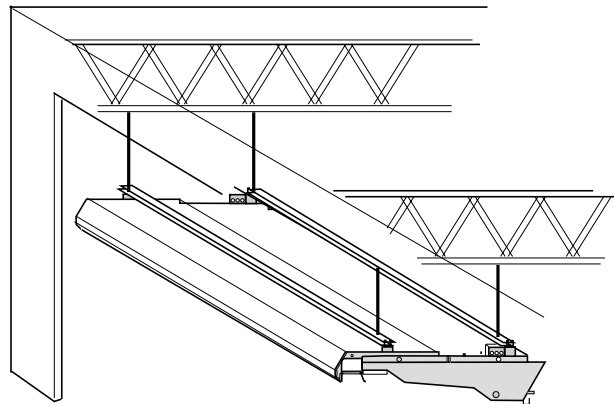

Field Supplied
Suspending Rods

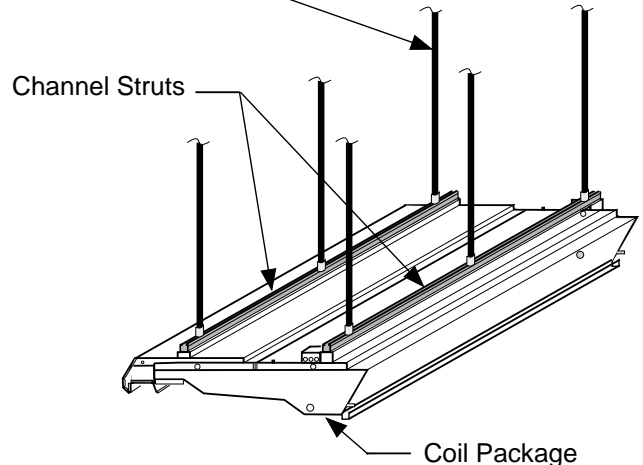

Installing Coil Package

Attach the coil package to the selected store structural support using the suggested drop rod size, quantity and fastening method, or as locally engineered. The coil package must be leveled.

Apply silicone sealant between the “L” bracket and bottom of cooler wall as shown. Fasten the “L” bracket at the top rear of the coil package to the cooler wall to prevent sway or lateral movement. The “L” bracket has holes for this purpose. Once lineup is complete, apply silicone or butyl sealant on outside where “L” bracket and wall meet, and on inside where wall and bracket meet to prevent condensation in walls. Sealing is also required to facilitate cleaning to NSF guidelines.

The channel struts with clamping nuts are provided to fasten the suspending rods. When tightening 1/2 in. (12.7 mm) threaded rods into nuts, ensure that the rods are firmly screwed into place. Vibration pads must be used if a machine room or other machinery is located above the structure that supports the coil package.

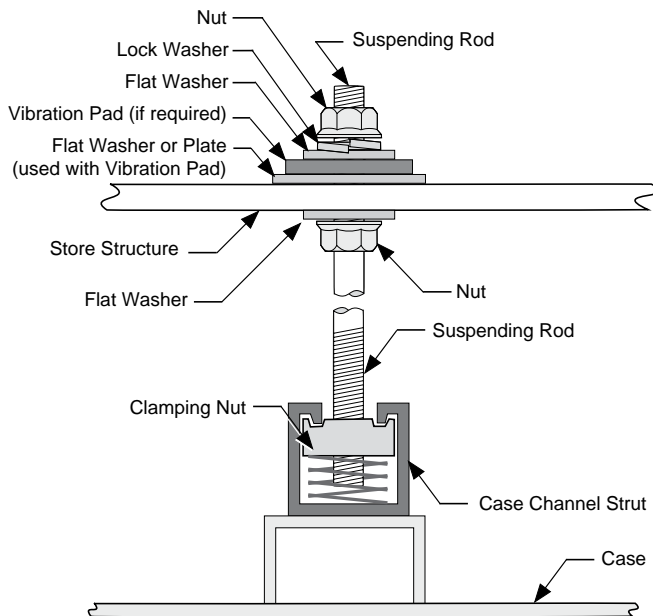

Installing Front Package

Align the front section with the canopy. Shim as necessary to maintain level. Fasten anchor brackets to floor. Seal as indicated.

INSTALLING D5XRRI

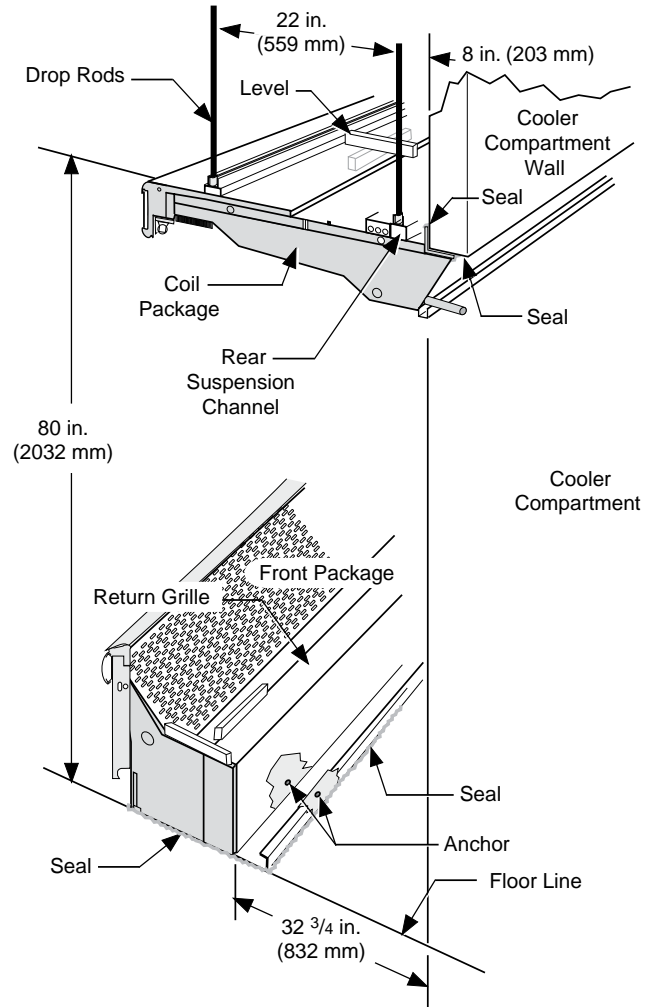



WARNING

Do NOT remove shipping braces until the merchandisers are positioned for installation. Once unfastened, NEVER LEAVE THE MERCHANDISER UNSUPPORTED OR UNATTENDED until it has been anchored.

The D5XRRI must be securely anchored to the floor and cooler wall after it has been leveled in its permanent position. Prelocated anchoring holes are provided in the front assembly, uprights, side braces, and top “L” bracket.

Sealing

For proper performance, safety and sanitation, apply a generous bead of sealant between the D5XRRI and the floor, between the D5XRRI top and sides and the cooler wall, around the interior perimeter of the base at the floor, and along the exterior front of the base at the floor.

REAR CURTAIN INSTALLATION

Rear curtains are provided with each case, two per 8 ft model, 3 per 12 ft model. Curtains should be installed just before start-up to prevent damage.

1. Slide all hangers onto track at rear of the case. Use **ALL** hangers so the curtains will drape properly.
2. Snap a stop clip onto each end of the track.
3. Hang curtains on hangers.

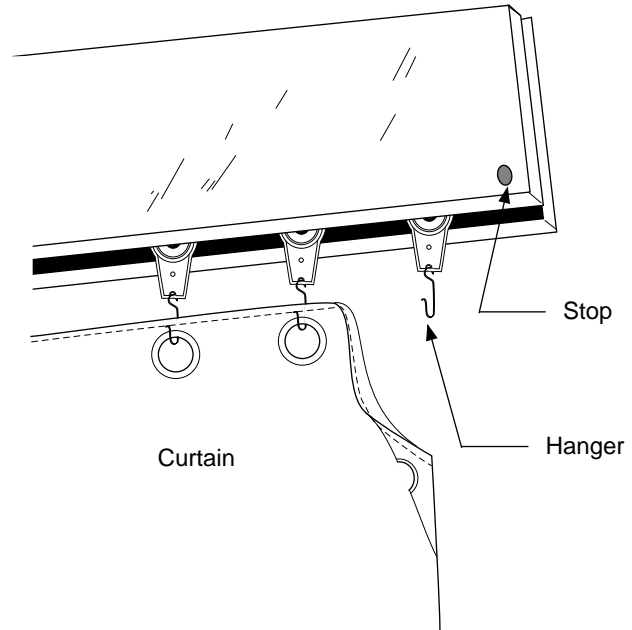

JOINING

Sectional construction means that two or more merchandisers may be joined in line yielding one long continuous display requiring only one pair of ends. **Joint kits and instructions are shipped with each merchandiser.**

To join like merchandisers, a joint assembly is required. A 1½ inch (38 mm) partition kit is required to join unlike merchandisers, or like merchandisers operating at different temperatures.

ALL JOINTS MUST BE AIR-TIGHT TO PREVENT FORMATION OF ICE OR CONDENSATION.

Refer to separate joining instruction shipped with each merchandiser.

INSTALLING PARTITIONS

To join unlike fixtures, or like merchandisers operating at different temperatures, a 1½ in. (38 mm) partition kit is required. Instructions for installing these partitions are included with the kits.

REFRIGERATION / ELECTRICAL

REFRIGERANT

The correct type of refrigerant will be stamped on each merchandiser's serial plate. The case refrigeration piping is leak tested, factory sealed and pressurized. Before making refrigeration hookups, depress the universal line valve to ensure that coils have maintained pressure during shipment.

WARNING

Refrigeration lines are under pressure and should be depressurized before attempting to make any connections.

REFRIGERANT PIPING

Connection Location

The refrigerant line connections are at the left-hand end of the merchandiser (as viewed from the front).

After connections have been made, seal this outlet thoroughly. Seal both the inside and the outside. We recommend using an expanding polyurethane foam insulation.

Multiplexing

Multiplex piping must be run above the top of the coil package in the area shown. Observe proper suction pipe joining practices and insulate all suction piping outside the merchandiser to prevent drippage from condensate.



CAUTION

When brazing pipes, be sure to use the insulation blanket shipped with the case to prevent damage to the case.

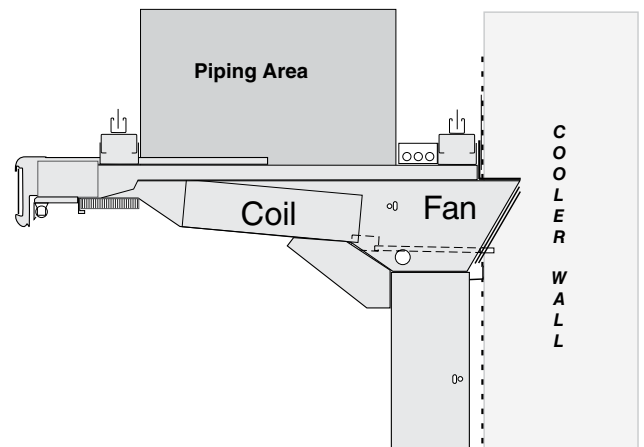

Line Sizing

Refrigerant lines should be sized as shown on the refrigeration legend that is furnished for the store or according to ASHRAE guidelines. Refer to the information on the next page for branch line piping of Hussmann Equipment.

Oil Traps

P-traps (oil traps) must be installed at the base of all suction line vertical risers.

Pressure Drop

Pressure drop can rob the system of capacity. To keep the pressure drop to a minimum, keep the refrigerant line run as short as possible using a minimum number of elbows. Where elbows are required, USE LONG RADIUS ELBOWS ONLY.

INSULATION

The suction and liquid lines should be clamped or taped together and insulated for a minimum of 30 ft (9144 mm) from the merchandiser.

Additional insulation for the balance of the liquid and suction lines is recommended wherever condensation drippage is objectionable or lines are exposed to ambient conditions.

SUCTION LINE

- Pitch in direction of flow.
- May be reduced by one size at one third of case run load and again after the second third. Do not reduce below the case suction line size.
- Merchandiser suction lines should enter at the top of the branch line.

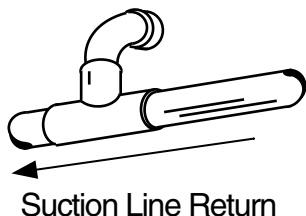

LIQUID LINE

- May be reduced by one size after one half the case run load. Do not reduce below the case liquid line connection size.
- Take-offs to merchandiser liquid lines should exit the bottom of the branch liquid line. Provide an expansion loop for each evaporator take-off (minimum 3 in. [76 mm] loop).

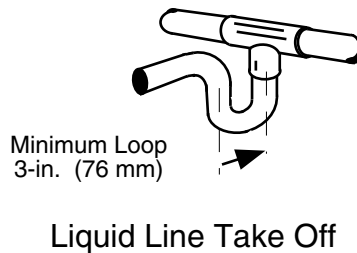

Offtime Defrost

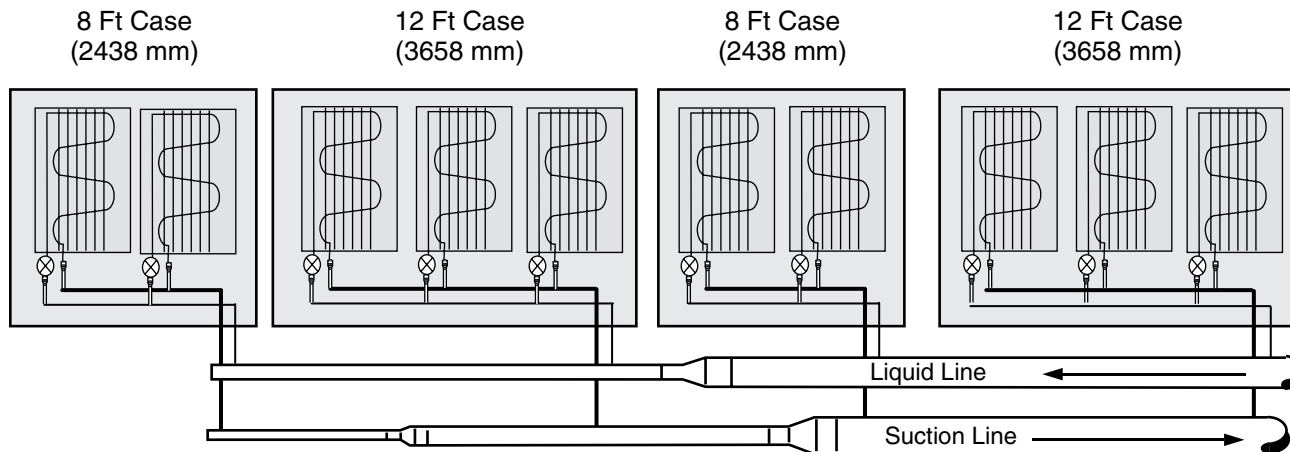

REFRIGERATION THERMOSTAT

The bulb for the optional refrigeration thermostat is located approximately 2 in. (51 mm) in front of the coil and 6 ft (1829 mm) from the right-hand end (facing front) of the case. The optional refrigeration thermostat is located 4 1/2 ft (1372 mm) from the right-hand end.

WARNING

— LOCK OUT / TAG OUT —

To avoid serious injury or death from electrical shock, always disconnect the electrical power at the main disconnect when servicing or replacing any electrical component. This includes, but is not limited to, such items as doors, lights, fans, heaters, and thermostats.

DEFROST TERMINATION

Rear load dairy cases are designed for time terminated defrost only. Refer to the merchandiser data sheet shipped with this manual for correct settings.

DEFROST SEQUENCES

These merchandisers require defrost cycles for proper operation. Refer to the data sheets for application data.

The Time Clock initiates defrost. The evaporator fans continue to circulate air across the evaporator coil, melting any frost build-up. Defrost must be time terminated.

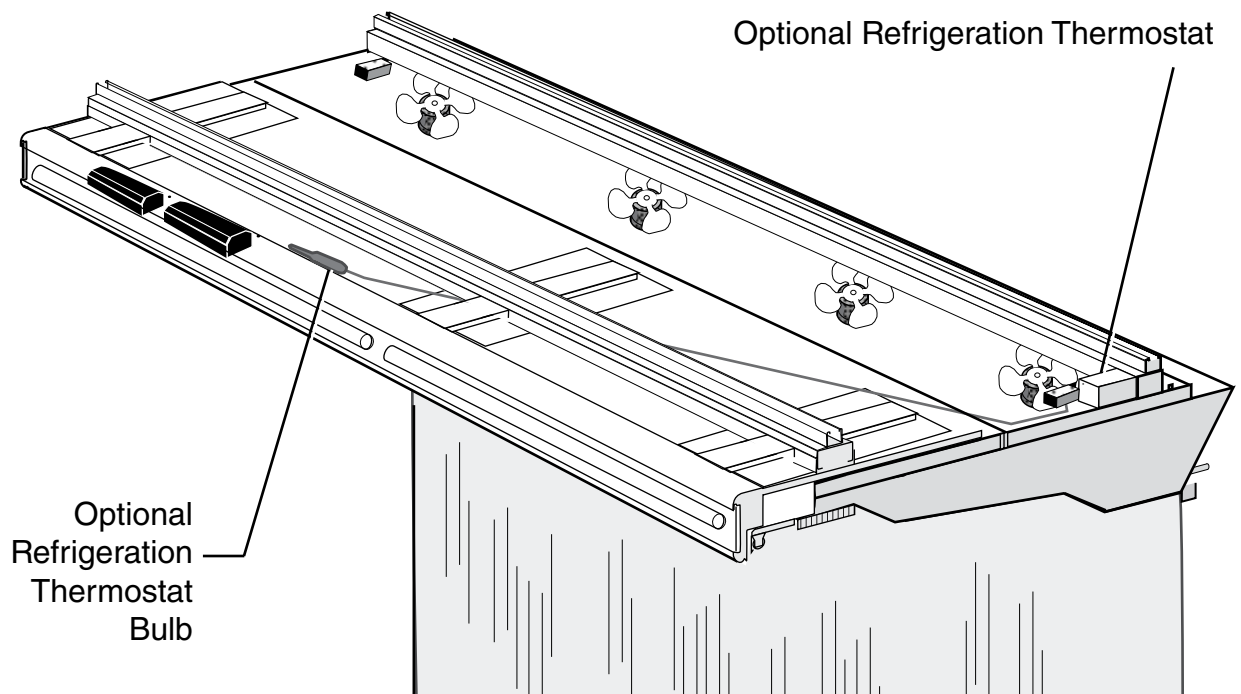

MERCHANDISER ELECTRICAL DATA

Merchandise data sheets are included with this manual. The data sheets provide merchandise electrical data, electrical schematics, parts lists and performance data. Refer to the merchandise data sheets and merchandise serial plate for electrical information.

ELECTRICAL CONNECTIONS

All wiring must be in compliance with NEC and local codes. *All electrical connections are to be made in the electrical raceway or Handy Box.*

FIELD WIRING

Field wiring must be sized for component amperes stamped on the serial plate. Actual ampere draw may be less than specified. Field wiring from the refrigeration control panel to the merchandisers is required for defrost termination thermostats and for optional refrigeration thermostats. When multiple merchandisers are on the same defrost circuit, the defrost termination thermostats are wired in series. **ALWAYS CHECK THE SERIAL PLATE FOR COMPONENT AMPERES.**

IDENTIFICATION OF WIRING

Leads for all electrical circuits are identified by colored plastic bands. These bands correspond to the *color code sticker* (shown below) located inside the merchandise's raceway.

 CAUTION
<p>Optional T8 rail lights and optional Quick Connect spray hose or field-installed misting system shall not be used together.</p>

ALWAYS CHECK THE SERIAL PLATE FOR COMPONENT AMPERES

<p>WIRING COLOR CODE</p> <p>Leads for all electrical circuits are identified by a colored plastic band: neutral wire for each circuit has either White insulation or a White plastic sleeve in addition to the color band.</p>	
<p>PINK REFRIG. THERMOSTAT LOW TEMP. LIGHT BLUE. REFRIG. THERMOSTAT NORM TEMP. DARK BLUE. DEFROST TERM. THERMOSTAT PURPLE CONDENSATE HEATERS BROWN FAN MOTORS GREEN* GROUND</p>	<p>ORANGE OR TAN LIGHTS MAROON .. RECEPTACLES YELLOW ... DEFROST HEATERS 120V RED DEFROST HEATERS 208V</p> <p style="text-align: center;">*EITHER COLORED SLEEVE OR COLORED INSULATION</p>
<p>ELECTRICIAN NOTE: Use copper conductor wire only. CASE MUST BE GROUNDED</p>	
<p>THESE ARE MARKER COLORS WIRES MAY VARY.</p>	

DRIP PIPING AND SPLASHGUARDS

WASTE OUTLET

A waste outlet is located at the back of the upper fan plenum, 1 1/4 in. (32 mm) from either end of the merchandiser.

It is the responsibility of the installing contractor to supply and connect drip pipe external to the case. External drip pipe may be flexible or rigid.

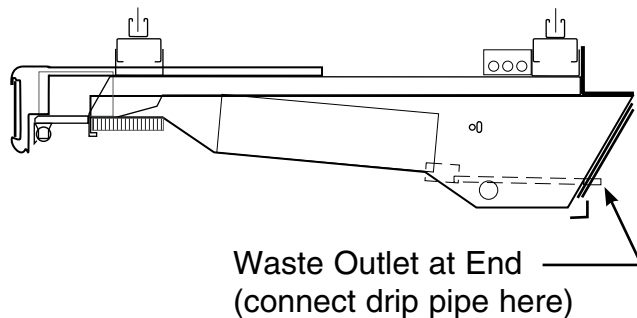

INSTALLING DRIP PIPING

Poorly or improperly installed drip pipes can seriously interfere with the merchandiser's operation and result in costly maintenance and product losses. Please follow the recommendations listed below when installing drip pipes to ensure proper installation.

1. Never use drip piping smaller than the nominal diameter of the piping inside the merchandiser.
2. When connecting drip piping, the "water seal" must be used as part of the drip piping to prevent air leakage or insect entrance. Never use two water seals in series in any one drip pipe. **DOUBLE WATER SEALS IN SERIES WILL CAUSE AN AIR LOCK AND PREVENT DRAINING.**
3. Pitch the drip piping in the direction of flow. There should be a minimum pitch of 1/4 in. per ft (20 mm per 1m).

4. Avoid long runs of drip piping. Long runs make it impossible to provide the pitch necessary for good drainage.

5. Provide a suitable air break between flood rim of the floor drain and outlet of drip pipe. To meet code on low base cases, it may be necessary to install a field-supplied drip pipe reducer. An alternative is to cut the last section of drip pipe at an angle.



6. Prevent drip pipes from freezing:
 - A. Do NOT install drip pipes in contact with uninsulated suction lines. Suction lines should be insulated with a nonabsorbent insulation material.
 - B. Where drip pipes are located in dead air spaces, such as between cases or between a case and a store wall, provide means to prevent freezing.

SEALING SPLASHGUARD TO FLOOR

Stainless steel splashguards may be sealed to the floor using a vinyl cove base trim. The size of trim needed will depend on how much the floor is out of level.

To install the trim to the splashguard:

1. Remove all dirt, wax and grease from the area of the splashguard where adhesion will be necessary. This is to ensure a good and secure installation.
2. Apply a good contact cement to the cove trim and allow proper drying time according to the directions supplied with the cement.

3. Install the trim to the splashguard so that it is lying flush with the floor. The Cove Trim may be sealed to the floor using a silicone sealer.

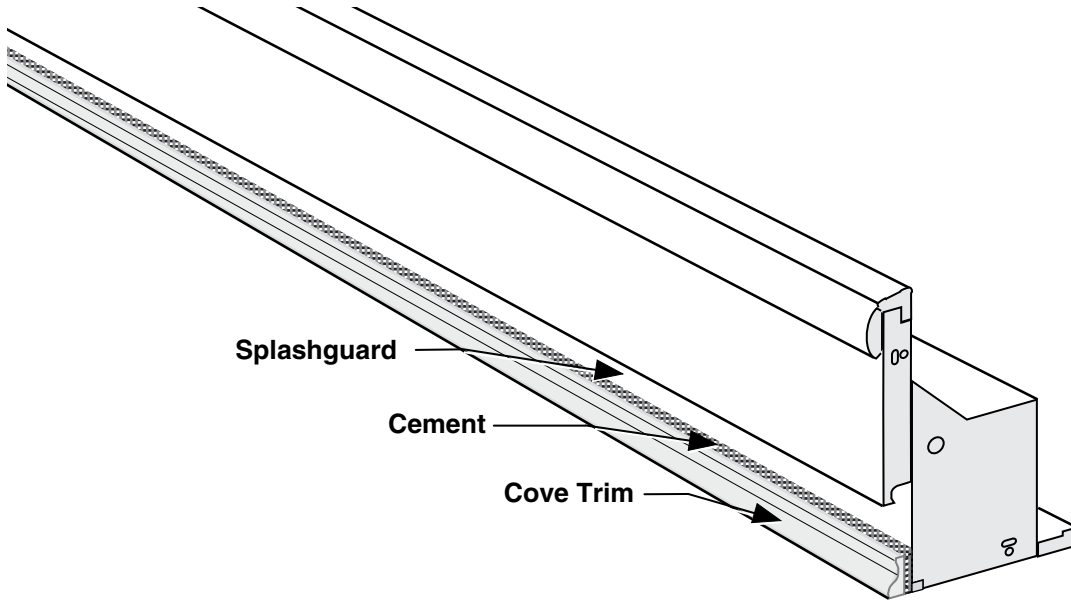

Apply Cove Base Trim to Splashguard

START UP / OPERATION

START UP

See the specific model's Technical Data Sheet for refrigerant settings and defrost requirements. Bring merchandisers down to the operating temperatures listed on the data sheet.

Each four foot section has its own evaporator coil and pre-set non-adjustable thermostatic expansion valve (TEV). No adjustment is required. **DO NOT REMOVE THE CAP ON THE TEVs.** This cap is to be removed only for valve disassembly. Removal of this cap during case maintenance will result in refrigerant loss unless the system is first isolated and the refrigerant recovered.

 CAUTION
REMOVAL OF THE TEV CAP WILL RESULT IN REFRIGERANT LOSS UNLESS THE SYSTEM IS FIRST ISOLATED AND THE REFRIGERANT RECOVERED.

The TEV has been factory set to provide the recommended performance settings as specified on the merchandiser data sheets.

STOCKING

Product should **NOT** be placed in merchandisers until merchandiser is at proper operating temperature.

Proper rotation of product during stocking is necessary to prevent product loss. Always bring the oldest product to the front and set the newest to the back.

AIR DISCHARGE AND RETURN FLUES MUST REMAIN OPEN AND FREE OF OBSTRUCTION AT ALL TIMES to provide proper refrigeration and air curtain performance. Do not allow product, packages, signs, etc. to block these grilles.

Close-off curtains at the rear of the D5XRR1 and D5XRRIS must be kept closed except when stocking to avoid adverse refrigeration performance.

OPTIONAL SHELVING

Product display shelving, lighted or unlighted, may be added to these cases with the addition of shelf support kits. These modular kits may be installed in the entire length or any 4 ft (1219 mm) section.

Shelf Supports

Two optional shelf support types are available. The stub shelf supports attach to the top coil package for one or two rows of shelves. The other shelf supports are 60 in. (1524 mm) tall, bolted to the floor, and support up to four rows of shelves.

An 8 ft (2438 mm) merchandiser has two columns of shelves; a 12 ft (3658 mm) merchandiser has three columns of shelves.

Shelves

Optional shelving is available in 20 in. (508 mm), 22 in. (559 mm), and 24 in. (610 mm) size. If using more than one size shelf in a column, the smallest shelf must be the highest

ACCESSORIES

Various display arrangements can be achieved by through combinations of shelves and mobile dairy carts. These carts are designed for quick loading, maneuverability, and sales appeal. After loading, the carts glide into the case from the rear. They can be positioned under optional shelving.

Do not use non-approved shelving, baskets, display racks, or any accessory that could hamper air curtain performance. Consult your Hussmann representative when in doubt about the effects of third-party accessories.

LOAD LIMITS

Shelf life of perishables will be short if load limit is violated. **AT NO TIME SHOULD CASES BE STOCKED BEYOND THE LOAD LIMITS INDICATED.**

DO NOT BLOCK HONEYCOMB.

INSTALLING FDA/NSF REQUIRED

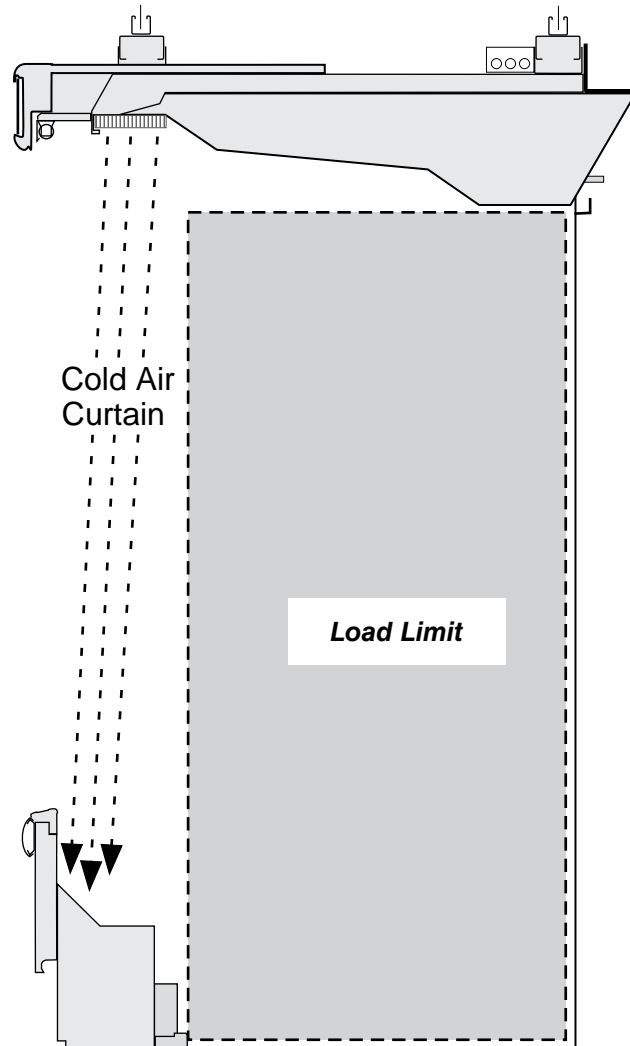

THERMOMETER

The following pages provide the same information that ships with the thermometer.

This requirement does not apply to display refrigerators intended for bulk produce (refer to page 1-1).

Please note that the tape cannot be exposed after installation.

This is an NSF-7 & US FDA Food Code Required Thermometer

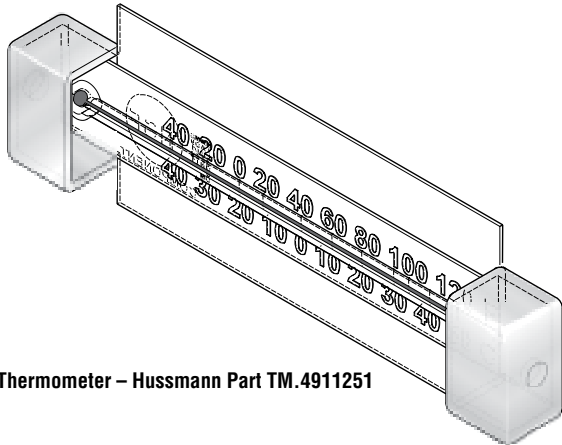

Thermometer – Hussmann Part TM.4911251

Hussmann Corporation • 12999 St. Charles Rock Road • Bridgeton, MO 63044-2483
U.S. & Canada 1-800-922-1919 • Mexico 1-800-522-1900 • www.hussmann.com
© 2007 Hussmann Corporation

Suggested Mounting Locations in Single Deck Glass Front Impact Merchandisers

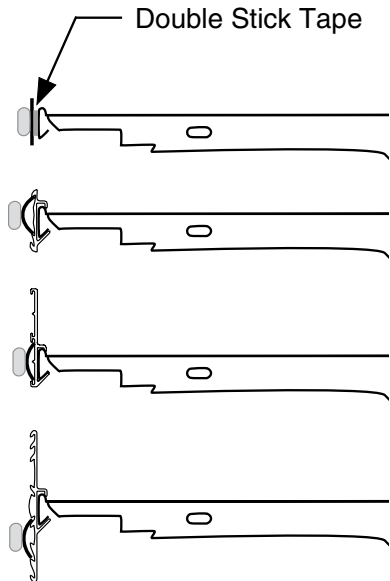
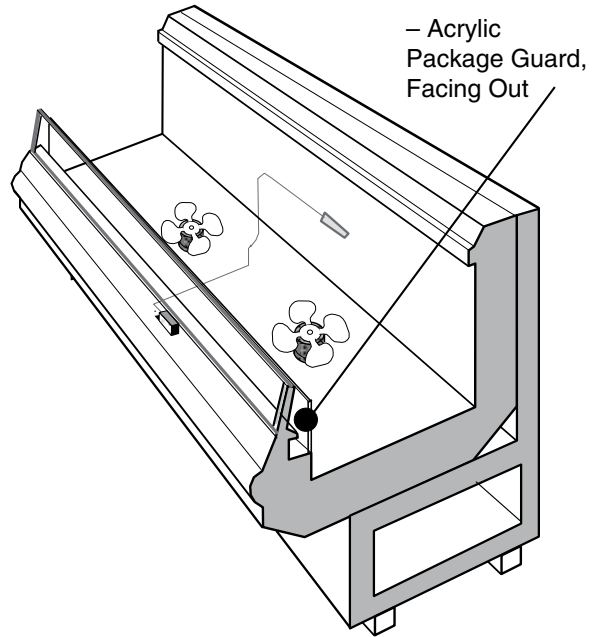

Flexible Plastic Fits in Price Tag Moldings

Hussmann P/N 0429971_C

10/2007

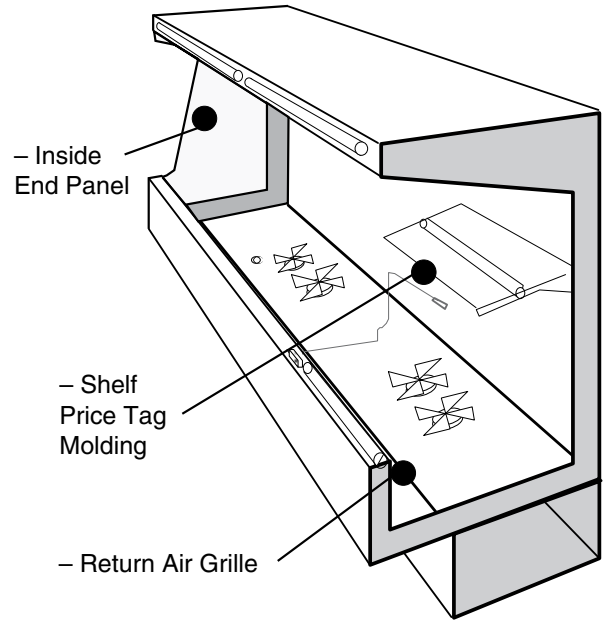

Suggested Mounting Locations in Multi-deck Merchandisers

Important – Please read!

This thermometer is provided in response to United States
Food and Drug Administration (US FDA) Food Code [<http://www.fda.gov/>]
and
National Sanitation Foundation (NSF / ANSI) Standard 7 [<http://www.nsf.org/>]

Each installation will be different depending on how the unit is stocked, shopping patterns in the department and ambient conditions of the store. The suggested locations provided herein are possible locations. It is the responsibility of the purchaser / user to determine the location with the food storage area of the unit that best meets the code requirements above.

The thermometer may need to be moved several times to find the warmest location. Mounting options include flexible plastic for price tag molding application, magnet applied to back of flexible plastic for steel end wall, and double stick tape. Tape must not be exposed after installation.

Questions about either code should be addressed to local agencies or other appropriate officials.

**Keep with merchandiser
or give to store manager.**

DO NOT DESTROY.

MAINTENANCE

CARE AND CLEANING

Long life and satisfactory performance of any equipment is dependent upon the care it receives. To ensure long life, proper sanitation and minimum maintenance costs, these cases should be thoroughly cleaned, all debris removed and the interiors washed down, weekly.

The store floor will be the interior display area of the rear roll-in dairy cases. Since milk and other spillage will occur, the floor should be cleaned and sanitized at least once each week.

When cleaning, use caution to prevent water or other liquids from entering the fan vents on the interior side of the front assembly.

Exterior Surfaces

The exterior surfaces must be cleaned with a mild detergent and warm water to protect and maintain their attractive finish. **NEVER USE ABRASIVE CLEANSERS OR SCOURING PADS.**



Interior Surfaces

The interior surfaces may be cleaned with most domestic detergents, ammonia based cleaners and sanitizing solutions with no harm to the surface.



Do NOT Use:

- Abrasive cleansers and scouring pads, as these will mar the finish.
- A hose on lighted shelves or submerge the shelves in water.
- Solvent, oil or acidic based cleaners on any interior surfaces.
- Coarse paper towels on coated glass.
- Ammonia-based cleaners on acrylic parts.
- A hose on rail lights, canopy lights or any other electrical connection.
- **STEAM OR HIGH WATER PRESSURE HOSES TO WASH THE INTERIOR. THESE WILL DESTROY THE CASES' SEALING CAUSING LEAKS AND POOR PERFORMANCE.**

Do:

- Remove the product and all loose debris to avoid clogging the waste outlet.
- Store product in a refrigerated area such as a cooler. Remove only as much product as can be taken to the cooler in a timely manner.
- **First turn off refrigeration, then disconnect electrical power.**
- Sweep the floor of the case.
- Thoroughly clean all surfaces with soap and hot water. **DO NOT USE STEAM OR HIGH WATER PRESSURE HOSES TO WASH THE INTERIOR. THESE WILL DESTROY THE CASES' SEALING CAUSING LEAKS AND POOR PERFORMANCE.**
- Take care to minimize direct contact between fan motors and cleaning or rinse water.
- Rinse with hot water, but do NOT flood. **NEVER INTRODUCE WATER FASTER THAN THE WASTE OUTLET CAN REMOVE IT.**
- Allow cases to dry before resuming operation.
- Wipe down lighted shelves with a damp sponge or cloth so that water does not enter the light channel. **DO NOT USE A HOSE OR SUBMERGE SHELVES IN WATER.** Wipe dry.
- After cleaning is completed, turn on power to the merchandiser.

CLEANING HONEYCOMB ASSEMBLIES

Upper Honeycomb

Honeycombs should be cleaned at least every six months. Dirty honeycombs will cause cases to perform poorly. The honeycombs may be cleaned with a vacuum cleaner. Soap and water may be used if all water is removed from the honeycomb cells before replacing. Be careful not to damage the honeycombs.

1. Remove interior roof panel to free honeycomb.
2. Clean and dry the honeycomb.
3. After cleaning, replace honeycomb and interior roof panel.

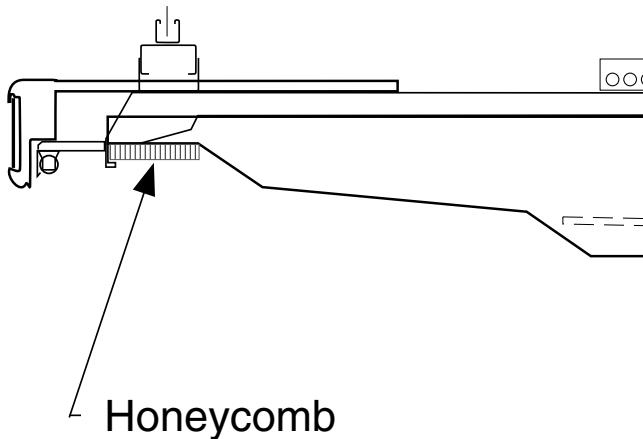

Lower Honeycomb

Starting at one lower end of the honeycomb, use a needle-nose plier to carefully compress and lift a corner. Work along the edge a few cells at a time until the honeycomb is free of the retainer. Clean and dry the honeycomb, then replace in reverse order.

Note that a damaged honeycomb must be replaced to maintain refrigeration efficiency.



WARNING

— LOCK OUT / TAG OUT —

To avoid serious injury or death from electrical shock, always disconnect the electrical power at the main disconnect when servicing or replacing any electrical component. This includes, but is not limited to, such items as doors, lights, fans, heaters, and thermostats.

REMOVING RETURN AIR GRILLE

Remove the screws holding each end of the retainer. Remove the retainer, then lift out the return air grille

Lower Fan Plenum

Remove the return air grille, then remove the screws that hold the plenum and lift out the plenum.

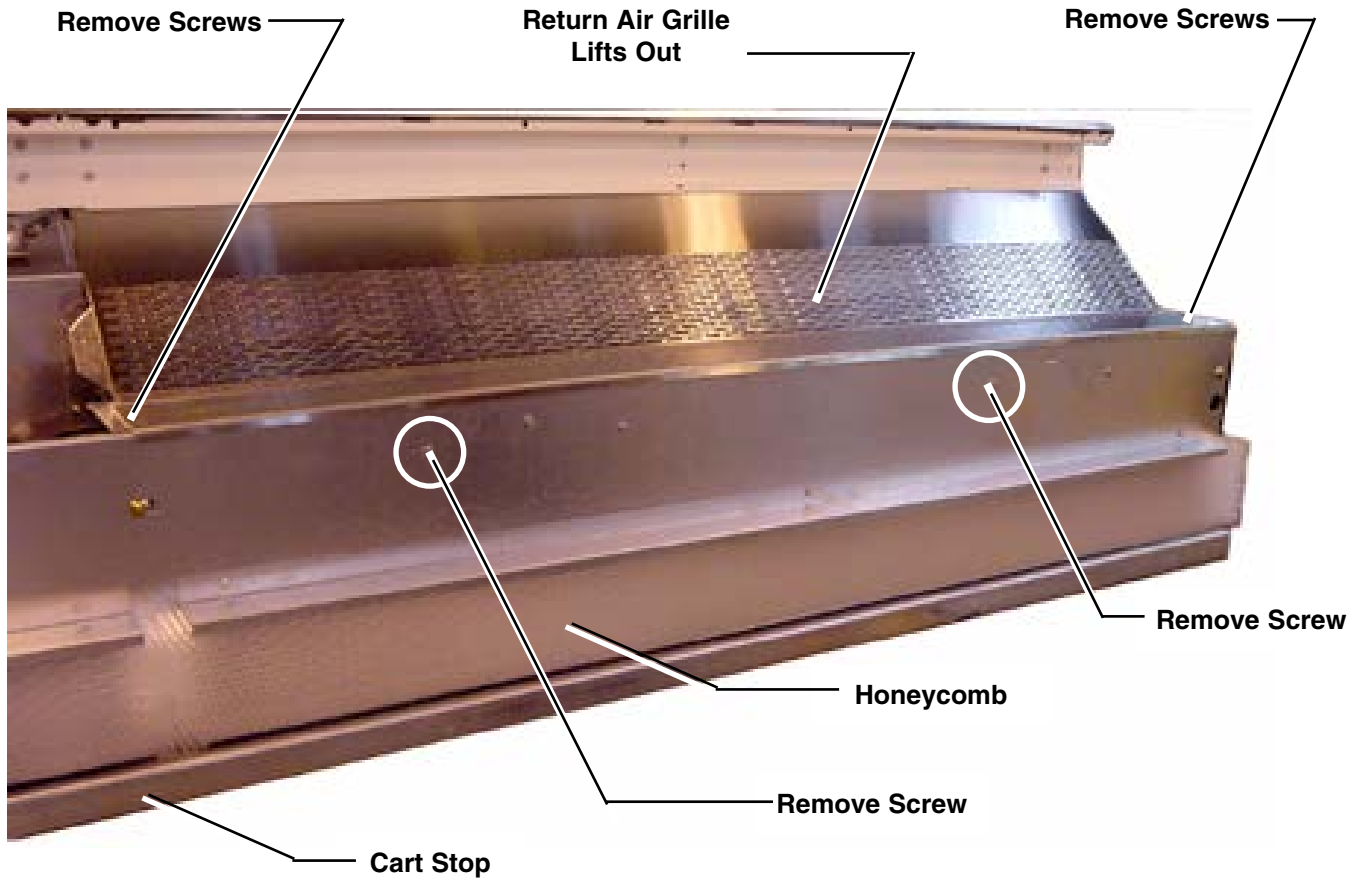

Interior View of D5XRRIS Front Package

Canopy Fan Plenum

To facilitate cleaning, the fan plenum is hinged. After cleaning be sure the plenum is returned to the proper position OR PRODUCT LOSS WILL RESULT due to improper refrigeration.

REMOVING SCRATCHES FROM BUMPER

Most scratches and dings can be removed using the following procedure.

1. Use steel wool to smooth out the surface area of the bumper or top rail.
2. Clean area.
3. Apply vinyl or car wax and polish surface for a smooth glossy finish.

SERVICE

REPLACING FAN MOTORS AND BLADES

See cross section for location of evaporator and return air fans. Should it ever be necessary to service or replace the fan motors or blades be certain that the fan blades are re-installed correctly.

For access to evaporator fans:

1. Turn off power.
2. Remove upper shelving.
3. **Disconnect fan from wiring harness.**
4. Remove fan mounting panel from coil module.
5. Remove wire fan guard.
6. Remove fan blade.
7. Remove screws holding bottom of motor to fan basket.
8. Replace fan motor and blade.
9. Re-install fan mounting panel in coil module.
10. Reconnect fan to wiring harness.
11. Turn on power. Verify that motor is working and blade is turning in the correct direction.
12. Ensure the fan plenum is located properly and that there are no air leaks which would adversely affect case performance.
13. Bring merchandiser to operating temperature before restocking.

For access to return air fans:

1. Turn off power.
2. Remove dairy carts, or bottom shelving.
3. Remove return air grille.
4. **Disconnect fan from wiring harness.**
5. Remove fan plenum from front package.
6. Remove fan blade.
7. Remove screws holding bottom of motor to fan basket.
8. Replace fan motor and blade.
9. Reconnect fan to wiring harness.
10. Re-install fan plenum and return grille
11. Turn on power. Verify that motor is working and blade is turning in the correct direction.
12. Ensure the fan plenum is located properly and that there are no air leaks which would adversely affect case performance.
13. Bring merchandiser to operating temperature before restocking.



WARNING

— LOCK OUT / TAG OUT —

To avoid serious injury or death from electrical shock, always disconnect the electrical power at the main disconnect when servicing or replacing any electrical component. This includes, but is not limited to, such items as doors, lights, fans, heaters, and thermostats.

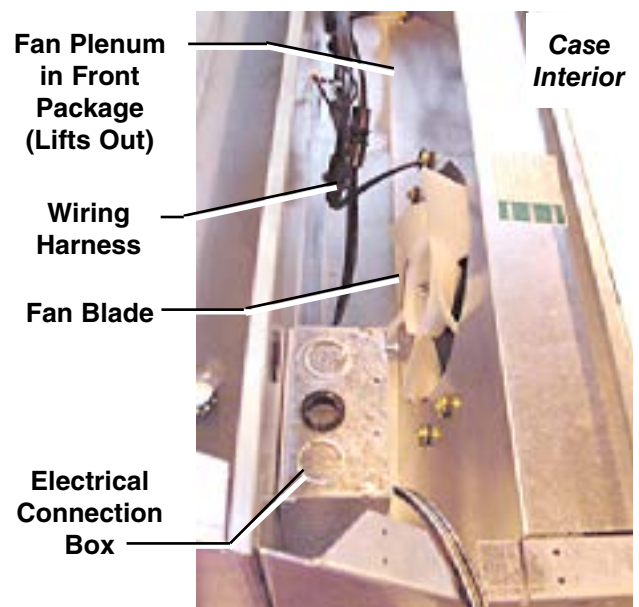

REPLACING LED CANOPY LIGHT BARS

There are always two rows of canopy LED lights. The rear light bar illuminates the upper section of the case and the front light bar illuminates the lower section of the case. The front and rear light bars are labeled **FRONT** and **REAR** respectively and have a different shaped lens. They shall not be interchanged.

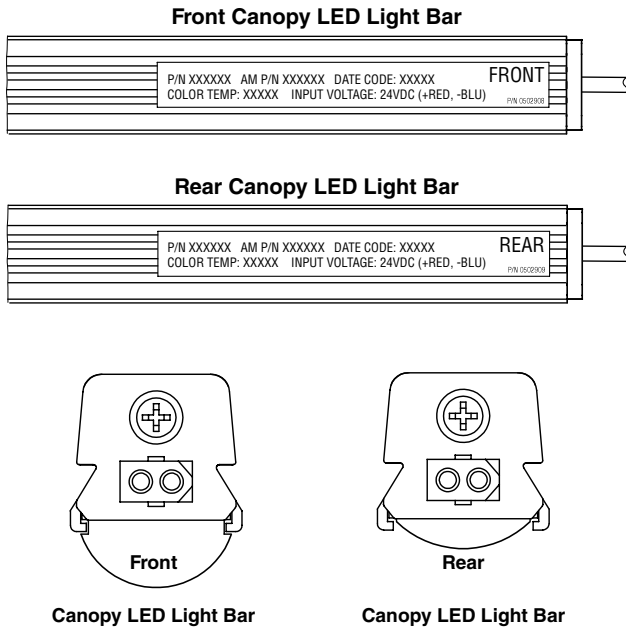

The light bars are connected through a two-conductor connector. Push on the release tab on the connector, then pull down on the connector. Do not pull on wires. LED power source is 24-volts for safety.

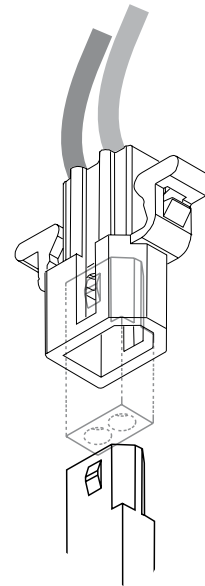

REPLACING LED Canopy LED Light Connector

The light bars are attached to the lamp panel using clips. When replacing clips ensure that the part number of the clip is the same as the original clip. The clips are color coded to simplify identification of the proper clip to be used.

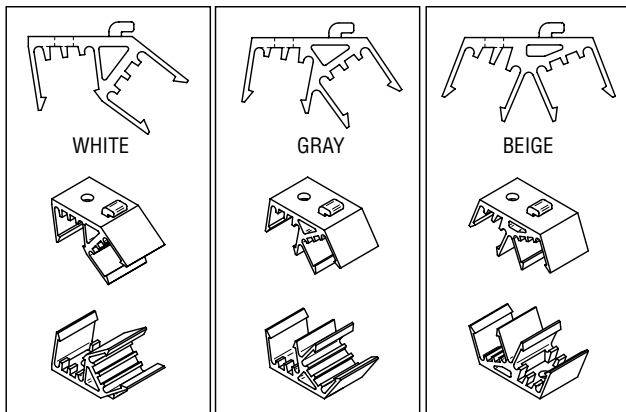

Light Bar Clips

SHELF LIGHT BARS

The LED shelf light bars are held in place using a magnetic surface on the back of the light bar.

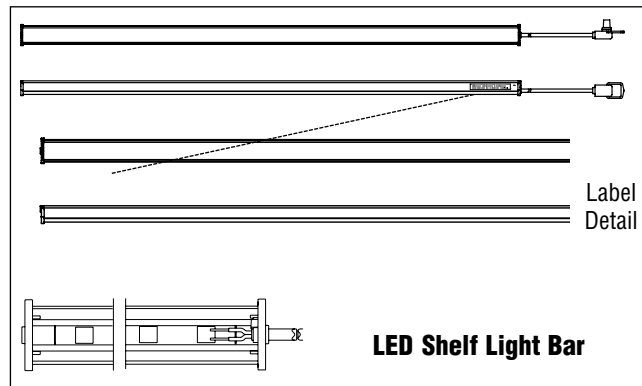

LED Shelf Light Bar

1. Turn off power to the merchandiser, and turn canopy light switch off. Unplug the shelf connector from its socket.

2. Replace with the appropriate Hussmann LED light bar.

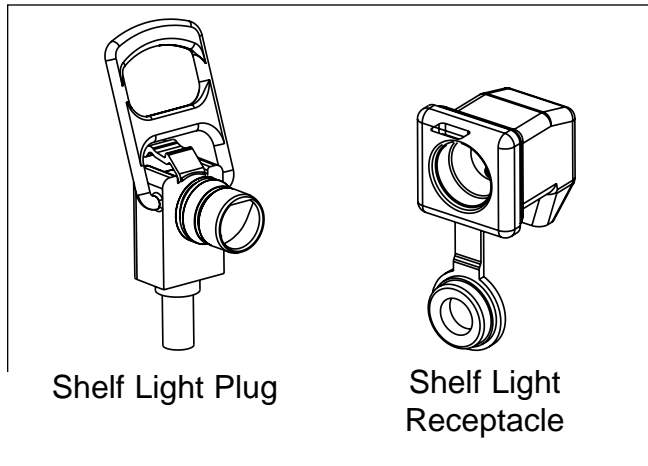

REPLACING LED POWER SUPPLIES

The LED power supplies for canopy lights and shelf lights are located at the top of the merchandiser inside the canopy.

1. **DISCONNECT POWER TO THE MERCHANDISER.**

2. Remove light bars from the canopy.

3. Remove the screws that secure the lamp panel.

4. Grasp the lamp panel at its front edge and carefully pull down. It will swing freely from its hinged rear edge.

5. Replace power supply and reassemble parts in reverse order.

6. Reconnect the electrical power.

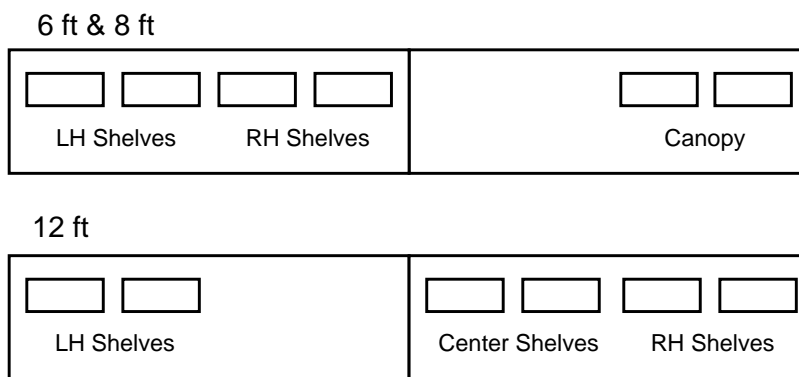
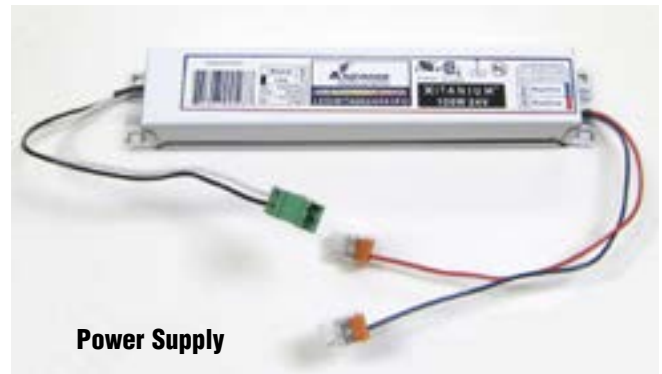

Canopy and Shelf LED Power Supply Arrangement

REPLACING FLUORESCENT LAMPS

Fluorescent lamps are furnished with moisture resistant lamp holders, shields and end caps. Whenever a fluorescent lamp is replaced, be certain to reinstall the lamp shields and end caps. The switch in the canopy operates both the canopy and the shelf lamps.

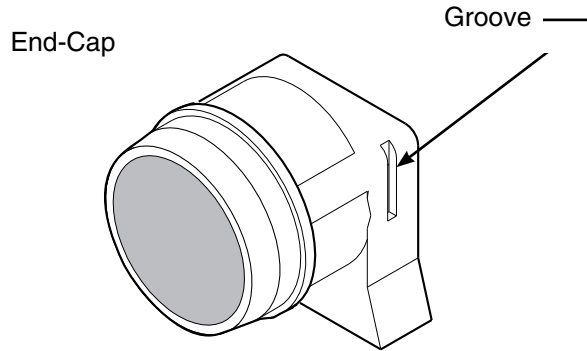
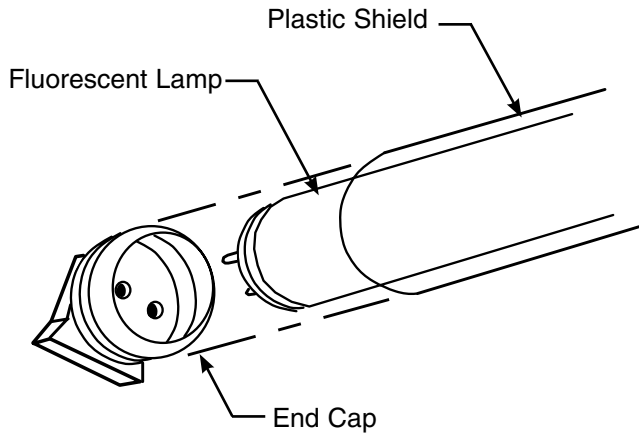

IMPORTANT!
Always replace lamp holders and end caps with Hussmann lamp holders and end caps.
Use of non-Hussmann parts may result in poor electrical contact and short lamp life.

REPLACING LAMP HOLDERS AND END CAPS

The Impact lamp holder is designed to snap into the sheet metal of the case. The lamp holder has a locking 'nub' which fits inside the groove of specially designed end caps.

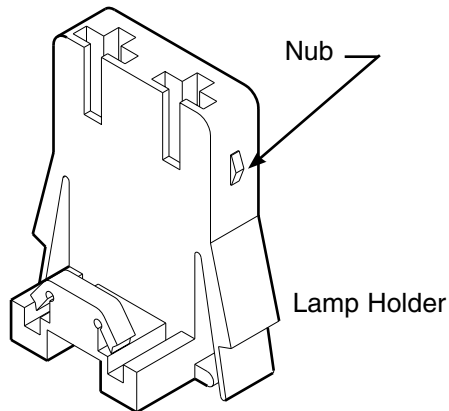

REPLACING BALLASTS

Canopy and Shelf Lamp Ballasts

These ballast are located at the top of the case inside the canopy. The switch in the canopy operates both the canopy and the shelf lamps. The rail lamp has a separate switch.

1. **DISCONNECT POWER TO THE CASE.**
2. Remove fluorescent lamps from the canopy.
3. Remove the screws that secure the lamp panel.
4. Grasping the light panel at the area where the top of the panel and the top of the case meet, pull back and down until the panel swings freely.
5. Replace ballast and reassemble parts in reverse order.
6. Reconnect the electrical power.

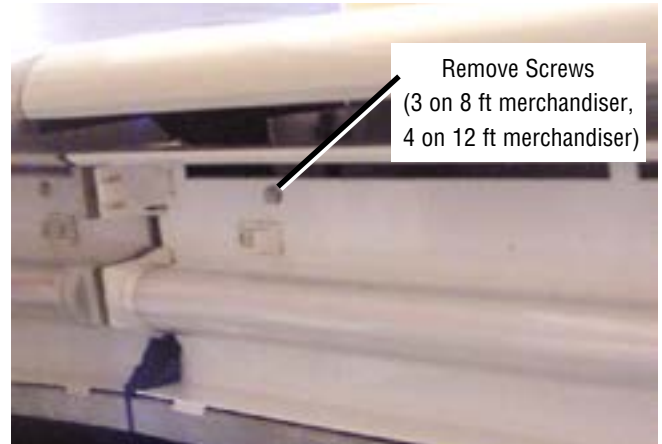

Remove Front Lamp Assembly to Access Screws



Access to Canopy and Shelf Ballasts

NOTE:

The ballast are in sequence from the left-hand end of the case (facing front) as follows:
 Farthest left, bottom shelf ballast, then center shelf or shelves, top shelf, first row canopy and last is second row canopy.

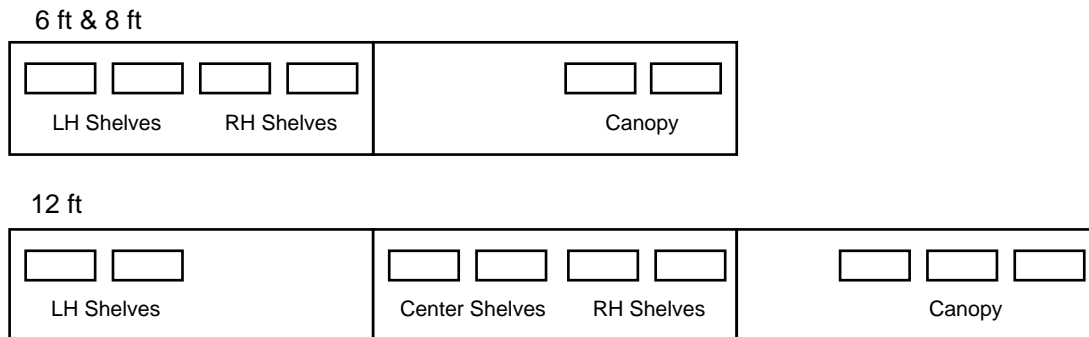

REPAIRING ALUMINUM COIL

The aluminum coils used in Hussmann cases may be easily repaired in the field. Materials are available from local refrigeration wholesalers.

Hussmann recommends the following solders:

Solders

Aladdin Welding Products Inc.
P.O. Box 49510-7188
1300 Burton St.
Grand Rapids, MI 49507
Phone: 1-800-645-3413
Fax: 1-800-645-3414

X-Ergon
1570 E. Northgate
P.O. Box 2102
Irving, TX 75062
Phone: 1-800-527-9916

NOTE:

Hussmann Aluminum melts at 1125°F (607°C)

Aladdin 3-in-1 rod at 732°F (389°C)

X-Ergon Acid core at 455°F (235°C)

Technique:

1. Locate Leak.
2. REMOVE ALL PRESSURE.
3. Brush area UNDER HEAT.
4. Use PRESTOLITE TORCH ONLY. Number 6 tip.
5. Maintain separate set of stainless steel brushes, and USE ONLY ON ALUMINUM.
6. Tin surface around area.
7. Brush tinned surface UNDER HEAT, thoroughly filling the open pores around leak.
8. Repair leak. Let aluminum melt solder, NOT the torch.
9. Don't repair for looks. Go for thickness.
10. Perform a leak check.
11. Wash with water.
12. Cover with a good flexible sealant.



HUSSmann[®]

To obtain warranty information
or other support, contact your
Hussmann representative.
Please include the model and
serial number of the product.

U.S. & Canada 1-800-922-1919 • Mexico 1-800-522-1900
www.hussmann.com

Husmann Corporation
Ingersoll Rand Climate Solutions
12999 St. Charles Rock Road
Bridgeton, MO 63044

www.husmann.com