

HOW TO ORDER TUBULAR AXLE ASSEMBLIES

Our part numbers for axles are assigned in accordance to the capacity, bolt pattern, type of brakes (if any) and type of spindle used. When ordering axles, the following information should be helpful to you.

EX: 20545I-ST-EZ 2,000 lb., 5 on 4 1/2" Idler Straight with E-Z Lube®

20 / 545 / I / ST / EZ

- 20:** The first group of digits represent the capacity (20 = 2,000 lb. capacity).
- 545:** The next group represents the number of studs and the bolt pattern of the studs (440 = 4 on 4", 545 = 5 on 4 1/2", 655 = 6 on 5 1/2", 865 = 8 on 6 1/2", etc.).
- I:** This tells you which type of brakes are used, if any:
(I = Idler, E = Electric, H = Hydraulic, HFB = Hydraulic Free-Backing, DS = Disc, A = Air).
- ST:** This tells you which type of spindles are used (ST = Straight, 4D = 4" Drop).
- EZ:** Any other options: (EZ = E-Z Lube® Spindle, SPR = Springs Mounted)



AXLE ASSEMBLIES

HOW TO DETERMINE CORRECT AXLE POSITION

1. Weigh the trailer (under wheels) "Wheel Weight"
2. Obtain "Tongue Weight" (Actual)
3. Measure distance from tongue to axle, or to center between Dual Axle Set (D)
4. Determine Total Weight
Total Weight = Tongue Weight + Wheel Weight

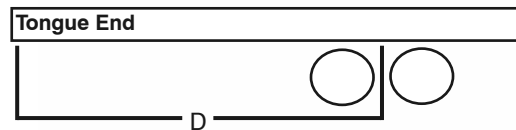

IF TONGUE WEIGHT IS GREATER THAN 10% OF TOTAL WEIGHT

If tongue weight is greater than 10% of Total Weight, decrease distance "D" by "X" where

$$X = \frac{(\text{Tongue Weight} - 10\% \text{ Total})}{\text{Total Weight}} \text{ Times } D$$

Example #1 - Tongue greater than 10% of Total Weight

Tongue Weight = 1025 lb.
Wheel Weight = 7200 lb.
D = 264"
Total Weight = 8225 lb.
% Tongue Weight = $\frac{1025}{8225} = 0.1246$ or 12 1/2%
"X" = $\frac{1025 - 822.5}{8225} \text{ Times } 264 = 6.499"$

Move the Axle(s) toward the Tongue of the trailer approximately 6 1/2"

$$\text{New } D = D - 6 \frac{1}{2}" = 264" - 6 \frac{1}{2}" = 257.5"$$

IF TONGUE WEIGHT IS LESS THAN 10% OF TOTAL WEIGHT

If tongue weight is less than 10% of Total Weight, increase distance "D" by "X" where

$$X = \frac{(10\% \text{ Total} - \text{Tongue Weight})}{\text{Total Weight}} \text{ Times } D$$

Example #2 - Tongue less than 10% of Total Weight

Tongue Weight = 300 lb.
Wheel Weight = 8200 lb.
D = 264"
Total Weight = 8500 lb.
% Tongue Weight = $\frac{300}{8500} = 0.035$ or 3 1/2%
"X" = $\frac{850 - 300}{8500} \text{ Times } 264 = 17"$

Move the Axle(s) toward the Rear of the trailer approximately 17"

$$\text{New } D = D + 17" = 264" + 17" = 281"$$



THE PROTECTIVE WIRING CONNECTOR!

The **primary cause of electric brake failure** is a loose or corroded connection in the brake wiring. The weakest point of the wiring connection is located under the trailer, at the axle, where the magnet wires exit the brake. Over time, the outer covering of the wires will become brittle and crack/break, exposing the wires and allowing the wires to short circuit against the trailer frame, axle, or against each other.

What is a protective wiring connector? It is an adjustable connector that attaches directly to the brake backing plate and allows you to attach most types of 1/2" I.D. conduit or loom to protect against rocks, dirt, snow, brush, etc.

This protective wiring connector may be ordered as a kit to retrofit existing axles (part #PWC1012), or may be pre-installed at the factory on new Dexter Axle assemblies for a minimal charge.

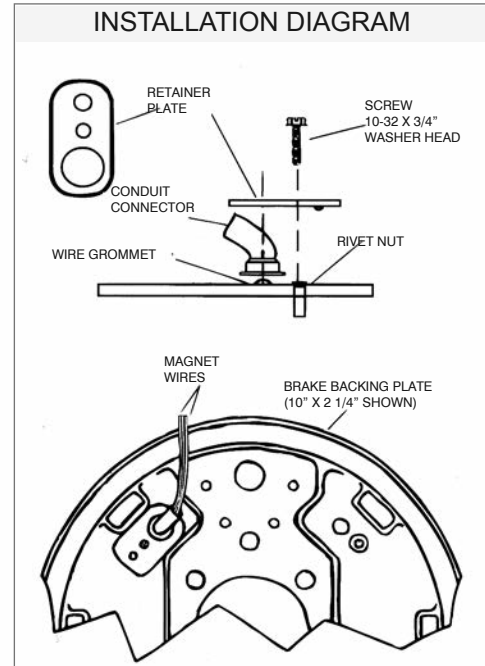

(Note: Axles ordered with the PWC option factory installed will not have the internal brake wiring inside the axle tube.) Protective Wiring Connector fits only Dexter Electric Brakes.

ABS BY DEXTER AXLE

8,000 lb. thru 27,500 lb. Axles can be supplied ABS equipped, with sensors and exciter rings pre-installed.

Regulation

All trailers with air brakes, manufactured after March 1, 1998, must now have ABS in order to comply with FMVSS 571.121. This standard also applies to air-over-hydraulic brake systems.

Required Equipment

An ABS system consists of wheel sensors that send electric impulses to an Electronic Control Unit (ECU) which pulses the service brakes in the event of wheel lockup. The minimum ABS configuration for a tandem axle trailer is a 2S/1M. This indicates two wheel sensors will be connected to and monitored by the ECU and one modulator valve will control the service brakes. 4S/2M ABS configuration is also available from Redline.

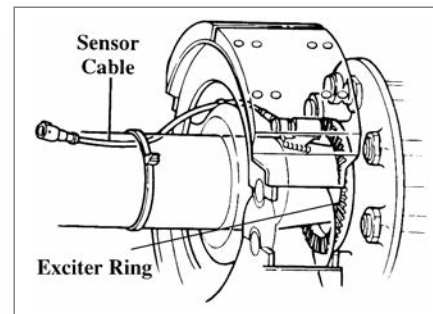
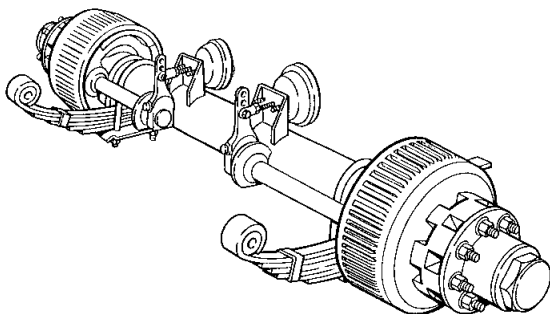



No need to pull the hubs to repack the bearings!
No need to replace seals when you check the brakes!
No more inner and outer bearings!

Pre-set Adjustments.

Ease of installation. Human error is virtually eliminated in bearing adjustment.

Pre-Lubricated at the Bearing Factory.

Resistant to contamination.

Sealed for Life.

No bearing maintenance*. Increased durability and reliability.

Lower maintenance cost.

5-year or 100,000 miles warranty against defects in material or workmanship.



Available in 42mm cartridge and 50mm cartridge.
*Subject to inspection procedure as outlined in Dexter Operation Maintenance Service Manual.

LUBRICATE THE E-Z LUBE® WAY!

Keep bearings protected the easy way. Use the E-Z Lube® Axle from Dexter.

The E-Z Lube® design allows grease to flow with EASE to both outer and inner bearings for a complete repack. It's easy because all you need to do is attach a grease gun at the end and insert the grease. No disassembly required! E-Z Lube®'s end cap allows for easy access, extra protection and no mess.

With such complete lubrication, your running gear is protected from corrosion. E-Z Lube® protection and maintenance features make it ideal for almost any towable axle, whether it's for work or play.

Give your running gear the ultimate in protection and maintenance ease with E-Z Lube® from Dexter!

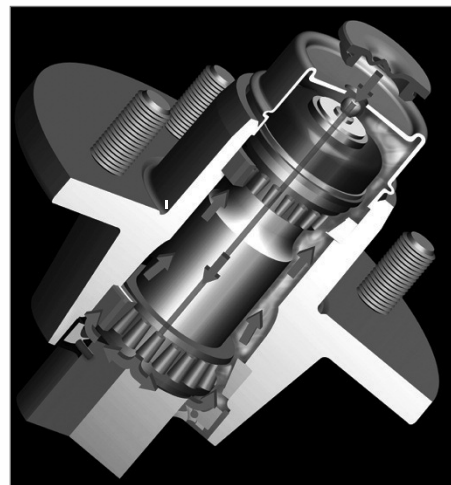

E-Z Lube® is subject to the maintenance and inspection procedures as outlined in the Dexter Operation Maintenance Service Manual.



2,200 lb



SPECIFICATIONS

Suspension:

Leaf Spring Suspension: (Choose from table on A-7)

- Double Eye versions
- Slipper Eye versions

(Spring Kits sold separately.)

Hanger Kit Options: See Section D

Bolt Pattern Options:

- 4 on 4"
- 5 on 4 1/2" – 5 Bolt available with:

5 1/2" Hub Flange – For 8" - 12" Wheels

6 1/2" Hub Flange – For 13" - 15" Wheels

Brake Options:

- 7" x 1 1/4" Electric With or without parking feature.
- 7" x 1 3/4" Hydraulic Uni-Servo (No Park)

Spindles: BTR Spindle, 1 1/16",

Uses L44649 Inner and Outer Bearings

- Straight • 4" Drop
- Stainless Steel Wear Sleeves on Galvanized Axles

Tubing:

- 1 3/4" OD (straight spindle only)
- 2 3/8" OD (drop spindle only)
- Galvanized Option (Marine), w/GAL-DEX™ Corrosion Resistant Hubs

Lubrications:

- Grease
- E-Z Lube®

Wheel Assemblies:

See Section E

Replacement Parts

Idler Hub: See Page B-10 and B-11

Hub/Drums: See Page B-16 and B-17

Brakes: See Page C-7 and C-21

Axle Beams: See Page B-1

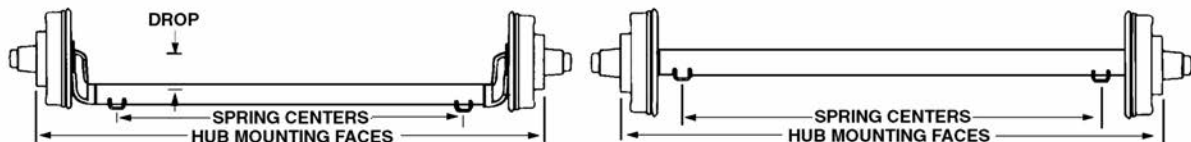

DIFFERENCE BETWEEN HUB FACE AND SPRING CENTER

Axle Type	Minimum	Maximum
STRAIGHT	11.50"	15.25"
DROP	15.25"	18.00"

NOTE: Minimums are based on manufacturing tolerances only. Some tire and wheel combinations may create interference.

2,200 LB. AXLE OPTIONS

Part No.	Ref. No.	Description
XTRA-HF-2K	002450	EXTRA CHARGE (PER AXLE) FOR 2.2K AXLES OVER 96" HF





AXLE ASSEMBLIES

2,200 LB. AXLE ASSEMBLIES		
Axle Type	4 on 4"	5 on 4 1/2"
Idler		
IDLER STRAIGHT	20440I-ST	20545I-ST
IDER STRAIGHT E-Z LUBE®	20440I-ST-EZ	20545I-ST-EZ
IDLER STRAIGHT, E-Z LUBE®, GALV	N/A	20545I-ST-EZG
IDLER 4" DROP	20440I-4D	20545I-4D
IDLER E-Z LUBE® 4" DROP	20440I-4D-EZ	20545I-4D-EZ
Electric		
ELECTRIC STRAIGHT	20440E-ST	20545E-ST
ELECTRIC STRAIGHT E-Z LUBE®	20440E-ST-EZ	20545E-ST-EZ
ELECTRIC 4" DROP	20440E-4D	20545E-4D
ELECTRIC E-Z LUBE® 4" DROP	20440E-4D-EZ	20545E-4D-EZ
Uni-Servo Hydraulic		
UNI-SERVO HYDRAULIC STRAIGHT	20440H-ST	20545H-ST
UNI-SERVO HYDRAULIC STRAIGHT E-Z LUBE®	20440H-ST-EZ	20545H-ST-EZ
UNI-SERVO HYDRAULIC 4" DROP	20440H-4D	20545H-4D
UNI-SERVO HYDRAULIC E-Z LUBE® 4" DROP	20440H-4D-EZ	20545H-4D-EZ

SPRING AND U-BOLT KITS FOR 2,200 LB. AXLES (SOLD SEPARATELY)					
Std. Kit Part No.	*Marine Kit Part No.	Per Spring Cap.	Length	Type	No. of Leaves
2-1020	2-1020M	1,000 LB	20 3/8"	DOUBLE EYE	3
2-1020-4D	N/A	1,000 LB	20 3/8"	DOUBLE EYE	3
2-PR-722	2-PR722M	1,250 LB	25 1/4"	DOUBLE EYE	3
2-PR-722-4D	N/A	1,250 LB	25 1/4"	DOUBLE EYE	3
2-WIC2	2-WIC2M	500 LB	23 1/8"	SLIPPER	2
2-WIC2-4D	N/A	500 LB.	23 1/8"	SLIPPER	2
2-WIE3	2-WIE3M	750 LB	23 1/8"	SLIPPER	3
2-WIE3-4D	N/A	750 LB	23 1/8"	SLIPPER	3
2-WIH4	2-WIH4M	1,000 LB	23 1/8"	SLIPPER	4
2-WIH4-4D	N/A	1,000 LB	23 1/8"	SLIPPER	4
2-WID2	2-WID2M	1,000 LB	27 3/8"	SLIPPER	2
2-WID2-4D	N/A	1,000 LB	27 3/8"	SLIPPER	2
2-WIF3	2-WIF3M	1,500 LB	27 3/8"	SLIPPER	3
2-WIF3-4D	N/A	1,500 LB	27 3/8"	SLIPPER	3
2-WIG4	2-WIG4M	1,750 LB	27 3/8"	SLIPPER	4
2-WIG4-4D	N/A	1,750 LB	27 3/8"	SLIPPER	4

*Our Marine U-Bolt Kits contain galvanized tie-plates, and zinc coated U-Bolts and Nuts.



2,200 lb - 3,500 lb

2" SQUARE TUBE MARINE AXLES



SPECIFICATIONS

Suspension:

Leaf Spring Suspension: (Choose from table on next page)

- Double Eye versions
 - Slipper Eye versions
- (Spring Kits sold separately.)

Hanger Kit Options: See Section D

Bolt Pattern Options:

- 5 on 4 1/2", GAL-DEX™ Marine Hubs & Hub/Drum

Brake Options:

- 10" x 2 1/4" Hydraulic Feedbacking, Corrosion Resistant (M35 Series Only)
- Optional Brake Flange (M22 Series)
- Std Brake Flange (M35 Series Idler) for Disc Brake Retrofit

Tubeing:

- 2" OD Square, Galvanized
- V-Bend Beam Option

Spindles:

- M22 Series: Straight BTR Spindle, 1 1/16", uses L44649 Inner & Outer Bearings
- M35 Series: Straight TT H (#84) Spindle, uses L68149 Inner Bearing, L44649 Outer Bearing
- Stainless Steel Wear Sleeves on Galvanized Axles

Lubrications:

- E-Z Lube®

Wheel Assemblies:

See Section E

Replacement Parts

Idler Hub: See Page B-11 and B-12

Hub/Drums: See Page B-18

Brakes: See Page C-22

Axle Beams: See Page B-1



DIFFERENCE BETWEEN HUB FACE AND SPRING CENTER		
Axle Type	Minimum	Maximum
M22 (2,200 LB)	12.94"	18.00"
M35 (3,500 LB)	12.38"	18.00"

NOTE: Minimums are based on manufacturing tolerances only. Some tire and wheel combinations may create interference.

2,200 LB. AXLE OPTIONS

Part No.	Ref. No.	Description
ADD-M2SQ-VCMBR	015210	ADD-ON, M22/M35 W/V-BEND OPTION



New Marine Items!



AXLE ASSEMBLIES

2" SQUARE MARINE AXLE ASSEMBLIES		
Axle Type	M22	M35
Idler	5 on 4 1/2"	5 on 4 1/2"
STRAIGHT E-Z LUBE®	M22545I-ST-EZ	M35545I-ST-EZ
Hydraulic Freebacking		
STRAIGHT E-Z LUBE®	N/A	M35545HFB-ST-EZ



DEXTER AXLE

SPRING AND U-BOLT KITS FOR 2,200 LB. AXLES (SOLD SEPARATELY)					
Std. Kit Part No.	Ref. No.	Per Spring Cap.	Length	Type	No. of Leaves
2-1020M-SQ	015215	1,000 LB	20 3/8"	DOUBLE EYE	3
2-PR722M-SQ	015216	1,250 LB	25 1/4"	DOUBLE EYE	3
2-WIC2M-SQ	015217	500 LB	23 1/8"	SLIPPER	2
2-WIE3M-SQ	015218	750 LB	23 1/8"	SLIPPER	3
2-WIH4M-SQ	015219	1,000 LB	23 1/8"	SLIPPER	4
2-WIH2M-SQ	015220	1,000 LB	27 3/8"	SLIPPER	2
2-WIF3M-SQ	015221	1,500 LB	27 3/8"	SLIPPER	3
2-WIG4M-SQ	015222	1,750 LB	27 3/8"	SLIPPER	4
2-PR3M-SQ	015223	1,750 LB	25 1/4"	DOUBLE EYE	3
2-PR4BM-SQ	015224	1,750 LB	25 1/4"	DOUBLE EYE	4
2-PR4M-SQ	015225	2,400 LB	25 1/4"	DOUBLE EYE	4



3,500 lb



SPECIFICATIONS

Suspension:

Leaf Spring Suspension: (Choose from table on next page)

- Double Eye versions
- Slipper Eye versions
(Spring Kits sold separately.)

Hanger Kit Options: See Section D

Bolt Pattern Options:

- 5 on 4 1/2", 4 3/4", 5" and 5 1/2"
- 6 on 5 1/2"

Brake Options: Some available with parking feature

- 10" x 2 1/4" Electric (Manual or Nev-R-Adjust®)
- 10" x 2 1/4" Hydraulic (Uni-Servo, Duo-Servo or Freebacking)
- 10" x 2 1/4" Hydraulic Freebacking Corrosion Resistant (Galv/Marine Axle)
- Hydraulic Disc: 5 on 4 1/2" only

Spindles: TTH (#84) Spindle

Uses L68149 Inner Bearing, L44649 Outer Bearing

- Straight • Drop: 4" or 6"
- Stainless Steel Wear Sleeves on Galvanized Axles

Tubing:

- 2 3/8" OD (Standard)
- Optional - 3" OD x LT wall
- Galvanized Option (Marine) w/GAL-DEX™ Corrosion Resistant Hubs
- V-Bend Beam Option

Lubrications:

- Grease
- E-Z Lube®

Wheel Assemblies:

See Section E

Replacement Parts

Idler Hub: See Page B-12

Hub/Drums: See Page B-18, B-19 and B-31 (Nev-R-Lube)

Brakes: See Page C-8 (Electric)

Axle Beams: See Page B-1

See Page C-22 (Hydraulic Drum)

See page B-33 (Hydraulic Disc)

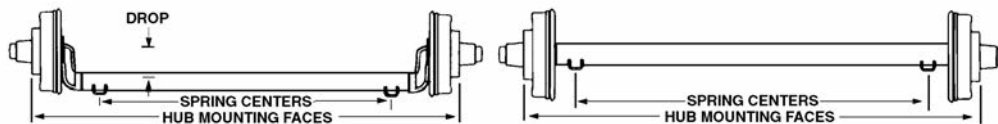

DIFFERENCE BETWEEN HUB FACE AND SPRING CENTER

Axle Type	Minimum	Maximum
Straight	11.25" (DISC=15.00")	18.00"
4" Drop	14.00" (DISC=15.00")	18.00"
3" Tube Straight	11.25"	23.00"
3" Tube 4" Drop	14.00"	23.00"

NOTE: Minimums are based on manufacturing tolerances only. Some tire and wheel combinations may create interference.

3,500 LB. AXLE OPTIONS

Part No.	Ref. No.	Description
ADD-3.5K-NEVRADJ	013016	ADD-ON (PER AXLE) 3.5K W/NEV-R-ADJUST® ELECTRIC BRAKE
ADD-3.5K-VCMBR	013624	ADD-ON, 3.5K W/V-BEND OPTION
XTRA-HF-3.5K	013625	EXTRA CHARGE (PER AXLE) FOR 3500 LB AXLE OVER 96" HUBFACE





AXLE ASSEMBLIES

3,500 LB. AXLE ASSEMBLIES					
Axle Type					
Idler	5 on 4 1/2"	5 on 4 3/4"	5 on 5"	5 on 5 1/2"	6 on 5 1/2"
STRAIGHT	35545I-ST	355475I-ST	35550I-ST	35555I-ST	35655I-ST
STRAIGHT E-Z LUBE®	35545I-ST-EZ	355475I-ST-EZ	35550I-ST-EZ	35555I-ST-EZ	35655I-ST-EZ
STRAIGHT, E-Z LUBE®, GALV	35545I-ST-EZG	N/A	N/A	N/A	N/A
4" DROP	35545I-4D	355475I-4D	35550I-4D	35555I-4D	35655I-4D
E-Z LUBE® 4" DROP	35545I-4D-EZ	355475I-4D-EZ	35550I-4D-EZ	35555I-4D-EZ	35655I-4D-EZ
Electric					
STRAIGHT	35545E-ST	355475E-ST	35550E-ST	35555E-ST	35655E-ST
STRAIGHT E-Z LUBE®	35545E-ST-EZ	355475E-ST-EZ	35550E-ST-EZ	35555E-ST-EZ	35655E-ST-EZ
4" DROP	35545E-4D	355475E-4D	35550E-4D	35555E-4D	35655E-4D
E-Z LUBE® 4" DROP	35545E-4D-EZ	355475E-4D-EZ	35550E-4D-EZ	35555E-4D-EZ	35655E-4D-EZ
Uni-Servo Hydraulic					
STRAIGHT	35545H-ST	355475H-ST	35550H-ST	35555H-ST	35655H-ST
STRAIGHT E-Z LUBE®	35545H-ST-EZ	355475H-ST-EZ	35550H-ST-EZ	35555H-ST-EZ	35655H-ST-EZ
4" DROP	35545H-4D	355475H-4D	35550H-4D	35555H-4D	35655H-4D
E-Z LUBE® 4" DROP	35545H-4D-EZ	355475H-4D-EZ	35550H-4D-EZ	35555H-4D-EZ	35655H-4D-EZ
Hydraulic Freeback					
STRAIGHT	35545HFB-ST	355475HFB-ST	35550HFB-ST	35555HFB-ST	35555HFB-ST
STRAIGHT E-Z LUBE®	35545HFB-ST-EZ	355475HFB-ST-EZ	35550HFB-ST-EZ	35555HFB-ST-EZ	35555HFB-ST-EZ
STRAIGHT, E-Z LUBE®, GALV	35545HFB-ST-EZG	N/A	N/A	N/A	N/A
4" DROP	35545HFB-4D	355475HFB-4D	35550HFB-4D	35555HFB-4D	35555HFB-4D
E-Z LUBE® 4" DROP	35545HFB-4D-EZ	355475HFB-4D-EZ	35550HFB-4D-EZ	35555HFB-4D-EZ	35555HFB-4D-EZ
Hydraulic Disc					
STRAIGHT	35545DS-ST	N/A	N/A	N/A	N/A
STRAIGHT E-Z LUBE®	35545DS-ST-EZ	N/A	N/A	N/A	N/A
4" DROP	35545DS-4D	N/A	N/A	N/A	N/A
E-Z LUBE® 4" DROP	35545DS-4D-EZ	N/A	N/A	N/A	N/A

SPRING AND U-BOLT KITS FOR 3,500 LB. AXLES (SOLD SEPARATELY)					
Std. Kit Part No.	*Marine Kit Part No.	Per Spring Cap.	Length	Type	No. of Leaves
2-PR3	2-PR3M	1,750 LB	25 1/4"	DOUBLE EYE	3
2-PR4B	2-PR4BM	1,750 LB	25 1/4"	DOUBLE EYE	4
2-PR4	2-PR4M	2,400 LB	25 1/4"	DOUBLE EYE	4
2-803T3	N/A	2,000 LB	25 7/8"	SLIPPER	4

*Our Marine U-Bolt Kits contain galvanized tie-plates, and zinc coated U-Bolts and Nuts.



4,400 lb



SPECIFICATIONS

Suspension:

Leaf Spring Suspension: (Choose from table on next page)

- Double Eye versions
- Slipper Eye versions
(Spring Kits sold separately.)

Hanger Kit Options: See Section D

Bolt Pattern Options:

- 6 on 5 1/2"

Brake Options:

- 10" x 2 1/4" Electric Hi-Performance
(Manual or Nev-R-Adjust®)

Spindles:

Uses L68149 Inner Bearing, LM67048 Outer Bearing

- Straight

Tubeing:

- 3" OD x LT wall

Lubrications:

- Grease
- E-Z Lube®

Wheel Assemblies:

See Section E

Replacement Parts

Hub/Drums: See Page B-19

Brakes: See Page C-8 (Electric)

Axle Beams: See Page B-1



DIFFERENCE BETWEEN HUB FACE AND SPRING CENTER

Axle Type	Minimum	Maximum
STRAIGHT	12.00"	19.00"

NOTE: Minimums are based on manufacturing tolerances only. Some tire and wheel combinations may create interference.





4,400 LB. AXLE OPTIONS		
Part No.	Ref. No.	Description
ADD-4.4K-NEVRADJ	015253	ADD-ON (PER AXLE) 4.4K W/NEV-R-ADJUST® ELECTRIC BRAKE
XTRA-HF-4.4K	015255	EXTRA CHARGE (PER AXLE) FOR 4.4K AXLE OVER 96" HF



4,400 LB. AXLE ASSEMBLIES	
Axle Type	
Idler	6 on 5 1/2"
STRAIGHT	44655E-ST
STRAIGHT E-Z LUBE®	446553-STEZ

SPRING AND U-BOLT KITS FOR 4,400 LB. AXLES (SOLD SEPARATELY)					
Std. Kit Part No.	Ref. No.	Per Spring Cap.	Length	Type	No. of Leaves
2-PR4-AH	015350	2,400 LB	25 1/4"	DOUBLE EYE	4
2-803T3-AH	015375	2,000 LB.	25 7/8"	SLIPPER	4



6,000 lb Regular Duty

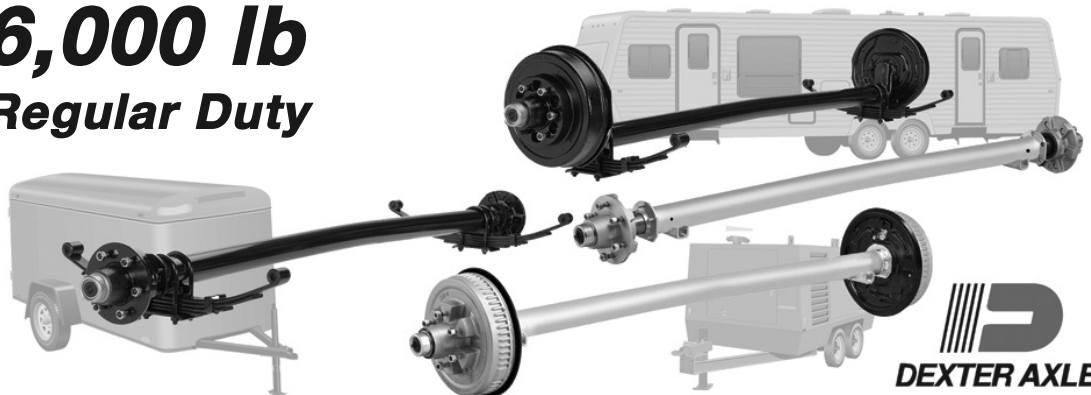

SPECIFICATIONS

Suspension:

Leaf Spring Suspension: (Choose from table on next page)

- Double Eye versions
- Slipper Eye versions
(Spring Kits sold separately.)

Hanger Kit Options: See Section D

Bolt Pattern Options:

- 6 on 5 1/2"
- 8 on 6 1/2"
- UTG 5-Spoke

Brake Options: Some available with parking feature

- 12" x 2" Electric (Manual or Nev-R-Adjust®) or Hydraulic, Uni-Servo, Freebacking, or Duo-Servo
- 12" x 2" Hyd Freebacking Corrosion Resistant (Galv/Marine Axle)
- Hydraulic Disc: 6 on 5 1/2" only

Lubrications:

- Grease • E-Z Lube®
- Oil Bath • Nev-R-Lube®

Spindles: TTA (#42) Spindle, with 2 1/4" seal journal, Uses 25580 Inner Bearing, Uses 15123, LM671048 (5200 lb.) or 14125A (8 bolt) Outer Bearing

- Straight • 4" Drop
- Stainless Steel Wear Sleeves on Galvanized Axles

Tubing:

- 3" OD x LT wall
- Galvanized Option (Marine) w/GAL-DEX™ Corrosion Resistant Hubs
- V-Bend Beam Option

Wheel Assemblies:

See Section E

Replacement Parts

Idler Hub: See Page B-13 and B-14

Hub/Drums: See Page B-20 - B-22 and B-32 (Nev-R-Lube)

Hub/Rotor: See Page B-33

Brakes: See Page C-9 (Electric), C-23, C-24 (Hydraulic Drum), B-34 (Hydraulic Disc)

Axle Beams: See Page B-1

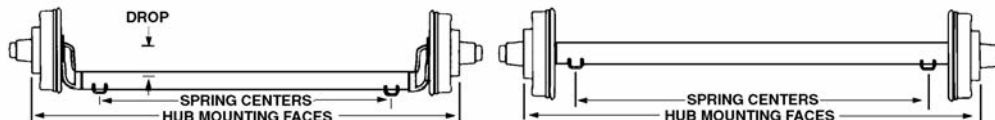

DIFFERENCE BETWEEN HUB FACE AND SPRING CENTER

Axle Type	Minimum	Maximum
*STRAIGHT	13.00" (DISC=18.00")	15.00"
DROP	15.75" (DISC=18.00")	17.50"

NOTE: Minimums are based on manufacturing tolerances only. Some tire and wheel combinations may create interference.

* Overhang on straight disc with 3" OD x LT wall derates axle tubing capacity to 5,200 lbs. Optional 3" OD x MED wall on disc brake applications required to maintain full 6,000 lbs.

6,000 LB. AXLE OPTIONS

Part No.	Ref. No.	Description
ADD-60R-VCMBR	018469	ADD-ON 60R W/V-BEND OPTION
XTRA-HF-60R	018472	EXTRA CHARGE (PER AXLE) FOR 60R AXLE OVER 96" HF
ADD-60R-NEVRADJ	018473	ADD-ON (PER AXLE) 60R W/ NEV-R-ADJUST® ELECTRIC BRAKE



6,000 LB. REGULAR DUTY AXLE ASSEMBLIES

Axle Type			
Idler	6 on 5 1/2"	8 on 6 1/2"	UTG 5-SPOKE
STRAIGHT	60R655I-ST	60R865I-ST	60RUTGI-ST
STRAIGHT E-Z LUBE®	60R655I-ST-EZ	60R865I-ST-EZ	60RUTGI-ST-EZ
STRAIGHT, E-Z LUBE®, GALV	60R655I-ST-EZG	60R865I-ST-EZG	N/A
STRAIGHT OIL BATH	N/A	60R865I-ST-OIL	60RUTOI-ST-OIL
4" DROP	60R655I-4D	60R865I-4D	60RUTGI-4D
4" DROP E-Z LUBE®	60R655I-4D-EZ	60R865I-4D-EZ	60RUTGI-4D-EZ
4" DROP OIL BATH	N/A	60R865I-4D-OIL	60RUTOI-4D-OIL
Electric			
STRAIGHT	60R655E-ST	60R865E-ST	60RUTGE-ST
STRAIGHT E-Z LUBE®	60R655E-ST-EZ	60R865E-ST-EZ	60RUTGE-ST-EZ
STRAIGHT OIL BATH	N/A	60R865E-ST-OIL	60RUTOE-ST-OIL
STRAIGHT, NEV-R-LUBE®	60R655E-ST-NL	N/A	N/A
4" DROP	60R655E-4D	60R865E-4D	60RUTGE-4D
4" DROP E-Z LUBE®	60R655E-4D-EZ	60R865E-4D-EZ	60RUTGE-4D-EZ
4" DROP OIL BATH	N/A	60R865E-4D-OIL	60RUTOE-4D-OIL
Uni-Servo Hydraulic			
STRAIGHT	60R655H-ST	60R865H-ST	60RUTGH-ST
STRAIGHT E-Z LUBE®	60R655H-ST-EZ	60R865H-ST-EZ	60RUTGH-ST-EZ
STRAIGHT, NEV-R-LUBE®	60R655H-ST-NL	N/A	N/A
STRAIGHT OIL BATH	N/A	60R865H-ST-OIL	60RUTOH-ST-OIL
4" DROP	60R655H-4D	60R865H-4D	60RUTGH-4D
4" DROP E-Z LUBE®	60R655H-4D-EZ	60R865H-4D-EZ	60RUTGH-4D-EZ
4" DROPOIL BATH	N/A	60R865H-4D-OIL	60RUTOH-4D-OIL
Uni-Servo Hydraulic Freeback			
STRAIGHT	60R655HFB-ST	60R865HFB-ST	60RUTGHFB-ST
STRAIGHT E-Z LUBE®	60R655HFB-ST-EZ	60R865HFB-ST-EZ	60RUTGHFB-ST-EZ
STRAIGHT E-Z LUBE®, GALV	60R655HFB-ST-EZG	60R865HFB-ST-EZG	N/A
STRAIGHT, NEV-R-LUBE®	60R655HFB-ST-NL	N/A	N/A
STRAIGHT OIL BATH	N/A	60R865HFB-ST-OIL	60RUTOHFB-ST-OIL
4" DROP	60R655HFB-4D	60R865HFB-4D	60RUTGHFB-4D
4" DROP E-Z LUBE®	60R655HFB-4D-EZ	60R865HFB-4D-EZ	60RUTGHFB-4D-EZ
4" DROPOIL BATH	N/A	60R865HFB-4D-OIL	60RUTOHFB-4D-OIL
Duo-Servo Hydraulic			
STRAIGHT	60R655HY-ST	60R865HY-ST	60RUTGHY-ST
STRAIGHT E-Z LUBE®	60R655HY-ST-EZ	60R865HY-ST-EZ	60RUTGHY-ST-EZ
STRAIGHT, NEV-R-LUBE®	60R655HY-ST-NL	N/A	N/A
STRAIGHT OIL BATH	N/A	60R865HY-ST-OIL	60RUTOHY-ST-OIL
4" DROP	60R655HY-4D	60R865HY-4D	60RUTGHY-4D
4" DROP E-Z LUBE®	60R655HY-4D-EZ	60R865HY-4D-EZ	60RUTGHY-4D-EZ
4" DROPOIL BATH	N/A	60R865HY-4D-OIL	60ROHY-4D-OIL
Hydraulic Disc			
STRAIGHT	60R655DS-ST	N/A	N/A
STRAIGHT E-Z LUBE®	60R655DS-ST-EZ	N/A	N/A
STRAIGHT, NEV-R-LUBE®	60R655DS-ST-NL	N/A	N/A
STRAIGHT OIL BATH	N/A	N/A	N/A
4" DROP	60R655DS-4D	N/A	N/A
4" DROP E-Z LUBE®	60R655DS-4D-EZ	N/A	N/A
4" DROPOIL BATH	N/A	N/A	N/A

SPRING AND U-BOLT KITS FOR 6,000 LB. AXLES (SOLD SEPARATELY)

Std. Kit Part No.	*Marine Kit Part No.	Per Spring Cap.	Length	Type	No. of Leaves
2-PR5	2-PR5M	2,900 LB	25 1/4"	DOUBLE EYE	5
2-PR6	2-PR6M	3,300 LB.	24 7/8"	DOUBLE EYE	6
2-E5226	2-E5226M	3,000 LB	25 1/4"	SLIPPER	5
2-1203T3	2-1203T3M	3,500 LB	24"	SLIPPER	5
2-1403T3	2-1403T3M	4,000 LB	24"	SLIPPER	7
2-E5115	2-E5115M	4,000 LB	27 1/2"	SLIPPER	6

NEW MARINE ITEMS *Our Marine U-Bolt Kits contain galvanized tie-plates, and zinc coated U-Bolts and Nuts.



AXLE ASSEMBLIES



6,000 lb Heavy Duty



SPECIFICATIONS

Suspension:

Leaf Spring Suspension: (Choose from table on next page)

- Double Eye versions
 - Slipper Eye versions
- (Spring Kits sold separately.)

Hanger Kit Options: See Section D

Bolt Pattern Options:

- 6 on 5 1/2"
- 8 on 6 1/2"
- UTG 5-Spoke

Brake Options: Some available with parking feature

- 12" x 2" Electric (Manual or Nev-R-Adjust®) or Hydraulic, Uni-Servo, Freebacking, or Duo-Servo
- 12" x 2" Hyd Freebacking Corrosion Resistant (Galv/Marine Axle)
- Hydraulic Disc: 6 on 5 1/2" only

Lubrications:

- Grease
- E-Z Lube®
- Oil Bath
- Nev-R-Lube®

Spindles: UTA (#42) Spindle, with 2 1/4" seal journal.

Uses 25580 Inner Bearing, Uses 15123 or 14125A (8 Bolt) Outer Bearing.

- Straight
- 4" Drop
- Stainless Steel Wear Sleeves on Galvanized Axles

Tubing:

- 3" OD x LT wall
- Galvanized Option (Marine) w/GAL-DEX™ Corrosion Resistant Hubs
- V-Bend Beam Option

Wheel Assemblies:

See Section E

Replacement Parts

Idler Hub: See Page B-13 and B-14

Hub/Drums: See Page B-20 - B-22 and B-32 (Nev-R-Lube)

Hub/Rotor: See Page B-33

Brakes: See Page C-9 (Electric), C-23, C-24 (Hydraulic Drum), B-34 (Hydraulic Disc)

Axle Beams: See Page B-1

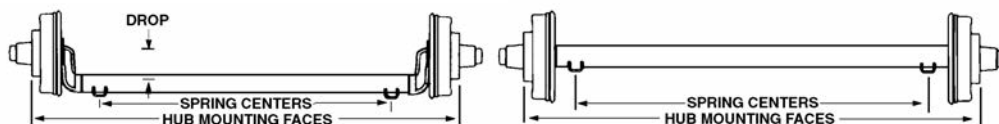

DIFFERENCE BETWEEN HUB FACE AND SPRING CENTER

Axle Type	Minimum	Maximum
STRAIGHT	13.00" (DISC=18.00")	20.00"
DROP	15.75" (DISC=18.00")	20.00"

NOTE: Minimums are based on manufacturing tolerances only. Some tire and wheel combinations may create interference.

6,000 LB. AXLE OPTIONS

Part No.	Ref. No.	Description
XTRA-HF-6K	020145	EXTRA CHARGE (PER AXLE) FOR 6K AXLES OVER 96" HF
ADD-6K-NEVRADJ	020146	ADD-ON (PER AXLE) 6K W/NEV-R-ADJUST® ELECTRIC BRAKE
ADD-6K-VCMBR	020148	ADD-ON 6K W/V-BEND OPTION



6,000 LB. HEAVY DUTY AXLE ASSEMBLIES

Axle Type			
Idler	6 on 5 1/2"	8 on 6 1/2"	UTG 5-SPOKE
STRAIGHT	60655I-ST	60865I-ST	60UTGI-ST
STRAIGHT E-Z LUBE®	60655I-ST-EZ	60865I-ST-EZ	60UTGI-ST-EZ
STRAIGHT, E-Z LUBE®, GALV	60655I-ST-EZG	60865I-ST-EZG	N/A
STRAIGHT OIL BATH	N/A	60865I-ST-OIL	60UTOI-ST-OIL
4" DROP	60655I-4D	60865I-4D	60UTGI-4D
4" DROP E-Z LUBE®	60655I-4D-EZ	60865I-4D-EZ	60UTGI-4D-EZ
4" DROP OIL BATH	N/A	60865I-4D-OIL	60UTOI-4D-OIL
Electric			
STRAIGHT	60655E-ST	60865E-ST	60UTGE-ST
STRAIGHT E-Z LUBE®	60655E-ST-EZ	60865E-ST-EZ	60UTGE-ST-EZ
STRAIGHT OIL BATH	N/A	60865E-ST-OIL	60UTOE-ST-OIL
STRAIGHT, NEV-R-LUBE®	60655E-ST-NL	N/A	N/A
4" DROP	60655E-4D	60865E-4D	60UTGE-4D
4" DROP E-Z LUBE®	60655E-4D-EZ	60865E-4D-EZ	60UTGE-4D-EZ
4" DROP OIL BATH	N/A	60865E-4D-OIL	60UTOE-4D-OIL
Uni-Servo Hydraulic			
STRAIGHT	60655H-ST	60865H-ST	60UTGH-ST
STRAIGHT E-Z LUBE®	60655H-ST-EZ	60865H-ST-EZ	60UTGH-ST-EZ
STRAIGHT, NEV-R-LUBE®	60655H-ST-NL	N/A	N/A
STRAIGHT OIL BATH	N/A	60865H-ST-OIL	60UTOH-ST-OIL
4" DROP	60655H-4D	60865H-4D	60UTGH-4D
4" DROP E-Z LUBE®	60655H-4D-EZ	60865H-4D-EZ	60UTGH-4D-EZ
4" DROPOIL BATH	N/A	60865H-4D-OIL	60UTOH-4D-OIL
Uni-Servo Hydraulic Freeback			
STRAIGHT	60655HFB-ST	60865HFB-ST	60UTGHFB-ST
STRAIGHT E-Z LUBE®	60655HFB-ST-EZ	60865HFB-ST-EZ	60UTGHFB-ST-EZ
STRAIGHT E-Z LUBE®, GALV	60655HFB-ST-EZG	60865HFB-ST-EZG	N/A
STRAIGHT, NEV-R-LUBE®	60655HFB-ST-NL	N/A	N/A
STRAIGHT OIL BATH	N/A	60865HFB-ST-OIL	60UTOHFB-ST-OIL
4" DROP	60655HFB-4D	60865HFB-4D	60UTGHFB-4D
4" DROP E-Z LUBE®	60655HFB-4D-EZ	60865HFB-4D-EZ	60UTGHFB-4D-EZ
4" DROPOIL BATH	N/A	60865HFB-4D-OIL	60UTOHFB-4D-OIL
Duo-Servo Hydraulic			
STRAIGHT	60655HY-ST	60865HY-ST	60UTGHY-ST
STRAIGHT E-Z LUBE®	60655HY-ST-EZ	60865HY-ST-EZ	60UTGHY-ST-EZ
STRAIGHT, NEV-R-LUBE®	60655HY-ST-NL	N/A	N/A
STRAIGHT OIL BATH	N/A	60865HY-ST-OIL	60UTOHY-ST-OIL
4" DROP	60655HY-4D	60865HY-4D	60UTGHY-4D
4" DROP E-Z LUBE®	60655HY-4D-EZ	60865HY-4D-EZ	60UTGHY-4D-EZ
4" DROPOIL BATH	N/A	60865HY-4D-OIL	60OHY-4D-OIL
Hydraulic Disc			
STRAIGHT	60655DS-ST	N/A	N/A
STRAIGHT E-Z LUBE®	60655DS-ST-EZ	N/A	N/A
STRAIGHT, NEV-R-LUBE®	60655DS-ST-NL	N/A	N/A
STRAIGHT OIL BATH	N/A	N/A	N/A
4" DROP	60655DS-4D	N/A	N/A
4" DROP E-Z LUBE®	60655DS-4D-EZ	N/A	N/A
4" DROPOIL BATH	N/A	N/A	N/A

SPRING AND U-BOLT KITS FOR 6,000 LB. AXLES (SOLD SEPARATELY)

Std. Kit Part No.	*Marine Kit Part No.	Per Spring Cap.	Length	Type	No. of Leaves
2-PR5	2-PR5M	2,900 LB	25 1/4"	DOUBLE EYE	5
2-PR6	2-PR6M	3,300 LB.	24 7/8"	DOUBLE EYE	6
2-E5226	2-E5226M	3,000 LB	25 1/4"	SLIPPER	5
2-1203T3	2-1203T3M	3,500 LB	24"	SLIPPER	5
2-1403T3	2-1403T3M	4,000 LB	24"	SLIPPER	7
2-E5115	2-E5115M	4,000 LB	27 1/2"	SLIPPER	6

NEW MARINE ITEMS *Our Marine U-Bolt Kits contain galvanized tie-plates, and zinc coated U-Bolts and Nuts.



AXLE ASSEMBLIES



7,000 lb

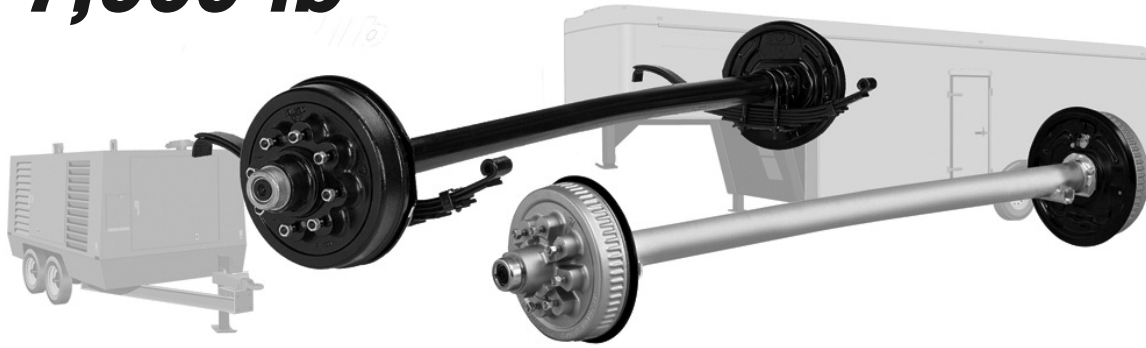

SPECIFICATIONS

Suspension:

Leaf Spring Suspension: (Choose from table on next page)

- Double Eye versions
 - Slipper Eye versions
- (Spring Kits sold separately.)

Hanger Kit Options: See Section D

Bolt Pattern Options:

- 8 on 6 1/2"
- UTG 5-Spoke

Brake Options: Some available with parking feature

- 12" x 2" Electric (Manual or Nev-R-Adjust®) or Hydraulic, Uni-Servo, Freebacking, or Duo-Servo Drum, Hydraulic Disc (Integral Hub/Rotor)
- 12" x 2" Hyd Freebacking Corrosion Resistant (Galv/Marine Axle)

Lubrications:

- Grease • E-Z Lube®
- Oil Bath • Nev-R-Lube®

Spindles: UTA (#42) Spindle, with 2 1/4" seal journal. Uses 25580 Inner Bearing, Uses 15123 (UTG) or 14125 (865) Outer Bearing.

- Straight • 4" Drop
- Stainless Steel Wear Sleeves on Galvanized Axles

Tubing:

- 3" OD x MED wall
- Galvanized Option (Marine) w/GAL-DEX™ Corrosion Resistant Hubs
- V-Bend Beam Option

Wheel Assemblies:

See Section E

Replacement Parts

- Idler Hub:** See Page B-14
- Hub/Drums:** See Page B-22, B-32 (Nev-R-Lube)
- Brakes:** See Page C-9 (Electric)
See Page C-23 - C-24 (Hyd. Drum)
See Page C-34 (Hyd. Disc)
- Axle Beams:** See Page B-1

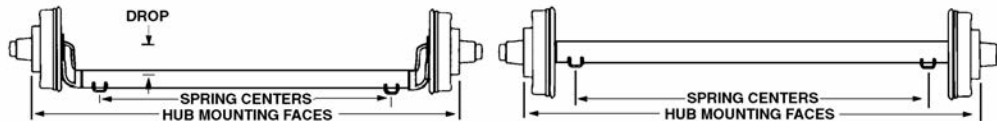

DIFFERENCE BETWEEN HUB FACE AND SPRING CENTER

Axle Type	Minimum	Maximum
STRAIGHT	13.00"	18.00"
DROP	15.75"	18.00"

NOTE: Minimums are based on manufacturing tolerances only. Some tire and wheel combinations may create interference.

7,000 LB. AXLE OPTIONS

Part No.	Ref. No.	Description
ADD-7K-VCMBR	022731	ADD-ON 7K W/V-BEND OPTION
XTRA-HF-7K	022732	EXTRA CHARGE (PER AXLE) FOR 7K AXLES OVER 96" HF
ADD-7K-NEVRADJ	022733	ADD-ON (PER AXLE) 7K W/NEV-R-ADJUST® ELECTRIC BRAKE



7,000 LB. REGULAR DUTY AXLE ASSEMBLIES

Axle Type		
Idler	8 on 6 1/2"	UTG 5-SPOKE
STRAIGHT	70865I-ST	70UTGI-ST
STRAIGHT E-Z LUBE®	70865I-ST-EZ	70UTGI-ST-EZ
STRAIGHT, E-Z LUBE®, GALV	70865I-ST-EZG	N/A
STRAIGHT OIL BATH	70865I-ST-OIL	70UTOI-ST-OIL
4" DROP	70865I-4D	70UTGI-4D
4" DROP E-Z LUBE®	70865I-4D-EZ	70UTGI-4D-EZ
4" DROP OIL BATH	70865I-4D-OIL	70UTOI-4D-OIL
Electric		
STRAIGHT	70865E-ST	70UTGE-ST
STRAIGHT E-Z LUBE®	70865E-ST-EZ	70UTGE-ST-EZ
STRAIGHT, NEV-R-LUBE®	70865E-ST-NL	N/A
STRAIGHT OIL BATH	70865E-ST-OIL	70OUTOH-ST-OIL
4" DROP	70865E-4D	70UTGE-4D
4" DROP E-Z LUBE®	70865E-4D-EZ	70UTGE-4D-EZ
4" DROP OIL BATH	70865E-4D-OIL	70UTOE-4D-OIL
Disc		
STRAIGHT	70865DS-ST	N/A
STRAIGHT E-Z LUBE®	70865DS-ST-EZ	N/A
STRAIGHT, NEV-R-LUBE®	N/A	N/A
STRAIGHT OIL BATH	70865DS-ST-OIL	N/A
4" DROP	70865DS-4D	N/A
4" DROP E-Z LUBE®	70865DS-4D-EZ	N/A
4" DROPOIL BATH	70865DS-4D-OIL	N/A
Uni-Servo Hydraulic		
STRAIGHT	70865H-ST	70UTGH-ST
STRAIGHT E-Z LUBE®	70865H-ST-EZ	70UTGH-ST-EZ
STRAIGHT, NEV-R-LUBE®	70865H-ST-NL	N/A
STRAIGHT OIL BATH	70865H-ST-OIL	70UTOH-ST-OIL
4" DROP	70865H-4D	70UTGH-4D
4" DROP E-Z LUBE®	70865H-4D-EZ	70UTGH-4D-EZ
4" DROPOIL BATH	70865H-4D-OIL	70UTOH-4D-OIL
Uni-Servo Hydraulic Freeback		
STRAIGHT	70865HFB-ST	70UTGHFB-ST
STRAIGHT E-Z LUBE®	70865HFB-ST-EZ	70UTGHFB-ST-EZ
STRAIGHT, NEV-R-LUBE®	70865HFB-ST-NL	N/A
STRAIGHT E-Z LUBE®, GALV	70865HFB-ST-EZG	N/A
STRAIGHT OIL BATH	70865HFB-ST-OIL	70UTOHFB-ST-OIL
4" DROP	70865HFB-4D	70UTGHFB-4D
4" DROP E-Z LUBE®	70865HFB-4D-EZ	70UTGHFB-4D-EZ
4" DROPOIL BATH	70865HFB-4D-OIL	70UTOHFB-4D-OIL
Duo-Servo Hydraulic		
STRAIGHT	70865HY-ST	70UTGHY-ST
STRAIGHT E-Z LUBE®	70865HY-ST-EZ	70UTGHY-ST-EZ
STRAIGHT, NEV-R-LUBE®	70865HY-ST-NL	N/A
STRAIGHT OIL BATH	70865HY-ST-OIL	70UTOHY-ST-OIL
4" DROP	70865HY-4D	70UTGHY-4D
4" DROP E-Z LUBE®	70865HY-4D-EZ	70UTGHY-4D-EZ
4" DROPOIL BATH	70865HY-4D-OIL	70UTOHY-4D-OIL

SPRING AND U-BOLT KITS FOR 7,000 LB. AXLES (SOLD SEPARATELY)

Std. Kit Part No.	*Marine Kit Part No.	Per Spring Cap.	Length	Type	No. of Leaves
2-PR5	2-PR5M	2,900 LB	25 1/4"	DOUBLE EYE	5
2-PR6	2-PR6M	3,300 LB.	24 7/8"	DOUBLE EYE	6
2-E5226	2-E5226M	3,000 LB	25 1/4"	SLIPPER	5
2-1203T3	2-1203T3M	3,500 LB	24"	SLIPPER	5
2-1403T3	2-1403T3M	4,000 LB	24"	SLIPPER	7
2-E5115	2-E5115M	4,000 LB	27 1/2"	SLIPPER	6

**NEW MARINE ITEMS

*Our Marine U-Bolt Kits contain galvanized tie-plates, and zinc coated U-Bolts and Nuts.



AXLE ASSEMBLIES



7,200 lb



SPECIFICATIONS

Suspension:

Leaf Spring Suspension: (Choose from table below)

- Double Eye versions
 - Slipper Eye versions
- (Spring Kits sold separately.)

Hanger Kit Options: See Section D

Bolt Pattern Options:

- 8 on 6 1/2" (9/16" studs standard or optional 5/8")

Brake Options:

- 12 1/4" x 2 1/2" Electric Only

Spindles: Uses 25580 Inner, 0247 Outer Bearings

- Straight
- 4" Drop

Tubing:

- 3" OD x HVY wall

Lubrications:

- Grease
- E-Z Lube®
- Oil Bath

Wheel Assemblies:

See Section E

Replacement Parts

Hub/Drums: See Page B-23

Brakes: See Page C-10 (Electric)

Axle Beams: See Page B-1

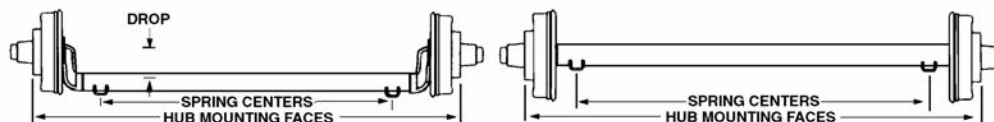

DIFFERENCE BETWEEN HUB FACE AND SPRING CENTER

Axle Type	Minimum	Maximum
STRAIGHT	14.00"	18.00"
DROP	15.75"	18.00"

NOTE: Minimums are based on manufacturing tolerances only. Some tire and wheel combinations may create interference.

7,200 LB. AXLE ASSEMBLIES

Axle Type	
Idler	8 on 6 1/2"
ELECTRIC STRAIGHT	72865E-ST
ELECTRIC STRAIGHT E-Z LUBE®	72865E-ST-EZ
ELECTRIC STRAIGHT OIL BATH	72865E-ST-OIL
ELECTRIC 4" DROP	72865E-4D
ELECTRIC 4" DROP E-Z LUBE®	72865E-4D-EZ
ELECTRIC 4" DROP OIL BATH	72865E-4D-OIL

SPRING AND U-BOLT KITS FOR 7,200 LB. AXLES (SOLD SEPARATELY)

Part No.	Ref. No.	Per Spring Cap.	Length	Type	No. of Leaves
2-PR5	023000	2,900 LB	25 1/4"	DOUBLE EYE	5
2-PR6	023100	3,300 LB	24 7/8"	DOUBLE EYE	6
2-E5226	023200	3,000 LB	25 1/4"	SLIPPER	5
2-1203T3	023300	3,500 LB	24"	SLIPPER	5
2-1403T3	023400	4,000 LB	24"	SLIPPER	7
2-E5115	023600	4,000 LB	27 1/2"	SLIPPER	6

7,200 LB. AXLE OPTIONS

Part No.	Ref. No.	Description
XTRA-HF-7.2K	022875	EXTRA CHARGE (PER AXLE) FOR 7.2K AXLES OVER 96" HUBFACE





8,000 lb



AXLE ASSEMBLIES

SPECIFICATIONS

Suspension:

Leaf Spring Suspension: (Choose from table below)

- Slipper Eye versions (Only)
(Spring Kits sold separately.)

Hanger Kit Options: See Section D

Bolt Pattern Options:

- 8 on 6 1/2" (9/16" studs standard or optional 5/8")

Brake Options: (Forward Self-Adjusting or Manual)

- 12 1/4" x 3 3/8" Electric
- 12 1/4" x 3 3/8" Hydraulic - Uni or Duo-Servo, parking feature available only with Uni-Servo, Manual Adj, Duo-Servo RSA
- Hydraulic Disc with ABS tone ring built-in
- ABS equipped option for hydraulic drum brakes

Spindles: Uses 25580 Inner, 0247 Outer Bearings

- Straight • 4" Drop

Tubing: • 3" OD x .250 wall, Optional 3.5" OD, .50 wall for Air-Ride

Lubrications:

- Grease • E-Z Lube® • Oil Bath • Nev-R-Lube®

Wheel Assemblies: See Section E

Replacement Parts

Idler Hub: See Page B-15

Hub/Drums: See Page B-25, B-32 (Nev-R-Lube)

Hub/Rotor: See Page B-36

Brakes: See Page C-11 (Electric), C-25 (Hyd. Drum), B-36 (Hyd. Disc)

Axle Beams: See Page B-1

8,000 LB. AXLE ASSEMBLIES	
Axle Type	
Idler	8 on 6 1/2"
STRAIGHT OIL BATH	80865I-ST
STRAIGHT E-Z LUBE®	80865I-ST-EZ
4" DROP OIL BATH	80865I-4D
4" DROP E-Z LUBE®	80865I-4D-EZ
Electric	
STRAIGHT OIL BATH	80865E-ST
STRAIGHT E-Z LUBE®	80865E-ST-EZ
STRAIGHT NEV-R-LUBE®	80865E-ST-NL
4" DROP OIL BATH	80865E-4D
4" DROP E-Z LUBE®	80865E-4D-EZ
Duo-Servo Hydraulic	
STRAIGHT OIL BATH	80865HY-ST
STRAIGHT E-Z LUBE®	80865HY-ST-EZ
STRAIGHT NEV-R-LUBE®	80865HY-ST-NL
4" DROP OIL BATH	80865HY-4D
4" DROP E-Z LUBE®	80865HY-4D-EZ
Hydraulic Disc	
STRAIGHT OIL BATH	80865DS-ST
STRAIGHT E-Z LUBE®	80865DS-ST-EZ
STRAIGHT NEV-R-LUBE®	80865DS-ST-NL
4" DROP OIL BATH	80865DS-4D
4" DROP E-Z LUBE®	80865DS-4D-EZ

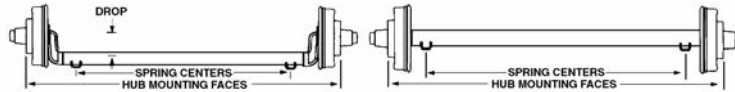

NOTE: Minimums are based on manufacturing tolerances only. Some tire and wheel combinations may create interference.

DIFFERENCE BETWEEN HUB FACE AND SPRING CENTER		
Axle Type	Minimum	Maximum
STRAIGHT	16.00"	19.00"
DROP	18.00"	19.00"

SPRING AND U-BOLT KITS FOR 8,000 LB. AXLES (SOLD SEPARATELY)					
Part No.	Ref. No.	Per Spring Cap.	Length	Type	No. of Leaves
2-E5226-8K	025200	3,000 LB	25 1/4"	SLIPPER	5
2-1203T3-8K	025250	3,500 LB	24 7/8"	SLIPPER	5
2-1403T3-8K	025600	4,000 LB	24 7/8"	SLIPPER	7
2-E5115-8K	025400	4,000 LB	27 1/2"	SLIPPER	6

8,000 LB. AXLE OPTION		
Part No.	Ref. No.	Description
XTRA-HF-8K	024960	EXTRA CHARGE (PER AXLE) FOR 8K AXLES OVER 96" HUBFACE
8K-ADD-HYABS	024980	EXTRA CHARGE (PER AXLE) FOR HYD DRUM AXLES W/ABS SENSORS & TONE RINGS INSTALLED
ADD-8KHD-WALL	024985	ADD ON FOR 8K AXLE, 3.5" OD .5" WALL TUBING FOR AIR-RIDE



9,000 lb



SPECIFICATIONS

Suspension:

Leaf Spring Suspension:

- Mounted 2" Wide Slipper Eye, Rubber Bushing (Spring Kits sold separately.)

Adjustable Spring Seat: For tracking alignment (optional).

Hanger Kit Options: See table below (sold separately).

Bolt Pattern Options:

- 8 on 6 1/2", 4.75 Pilot

Brake Options: (Forward Self-Adjusting)

- 12 1/4" x 3 3/8" Electric
- 12 1/4" x 3 3/8" Hydraulic - Uni or Duo-Servo, Parking feature available with Duo-Servo only.
- ABS Equipped option for Hydraulic Brakes

Spindles: Uses 387A Inner, 25580 Outer Bearing

- Straight*

Tubing:

- 4" OD

Lubrications:

- Oil Bath

Wheel Assemblies: See Section E

Replacement Parts

Hub/Drums: See Page B-26 - B-27

Brakes: See Page C-11, C-12 (Electric)
See Page C-25, C-26 (Hydraulic)

Axle Beams: See Page B-1

9,000 LB. AXLE ASSEMBLIES

Axle Type	8 on 6 1/2"
ELECTRIC	9K865E-NOSPR
DUO-SERVO HYDRAULIC	9K865HY-NOSPR
ABS Equipped	8 on 6 1/2"
ELECTRIC	N/A
DUO-SERVO HYDRAULIC	9K865HABS-NOSPR

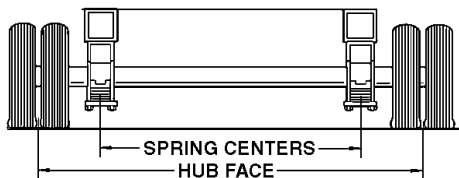

DIFFERENCE BETWEEN HUB FACE*/TRACK WIDTH* AND SPRING CENTER

Wheel	Minimum	Maximum
SINGLE (HF)	19.32	31.00
DUAL (TW)	26.00	31.00

*Hubface (HF) used to specify applications using single wheels.

*Track Width (TW) uses to specify applications using dual wheels.

NOTE: Dimensions are based on manufacturing tolerances only. Some tire and wheel combinations may create interference.

***Axle Replacements for axles before July 27, 2009 must specify "OLD STYLE" Spindle.**

9,000 LB. AXLE OPTIONS

Part No.	Ref. No.	Description
9KHYD-PARK	030400	HYDRAULIC BRAKES W/PARK, ADD TO 9K HYDRAULIC BRAKE AXLE
XTRA-HF-9K	030410	EXTRA CHARGE (PER AXLE) FOR 9K AXLES OVER 80" HUB FACE THROUGH 124"
9KADJ-SEAT	030415	ADJ SPG SEATS ALLOWS CORRECTION OF AXLE SPACING, PREVENTS SIDE TRACKING
2-72-10-2	030418	2 EA., 72-10-2 SPRINGS MTD ON ABOVE 9K AXLES
Hanger and Attaching Parts Kits for 9,000 lb. (Sold Separately)		
HAP-105-00	030420	9K SINGLE AXLE HANGER AND ATTACHING PARTS KIT
HAP-205-01	030440	9K MULTI-AXLE CONVERSION KIT FOR 38" AXLE SPACING
HAP-205-02	030460	9K MULTI-AXLE CONVERSION KIT FOR 42 1/4" AXLE SPACING
HAP-205-03	030480	9K MULTI-AXLE CONVERSION KIT FOR 48 1/2" AXLE SPACING



10,000 lb General Duty



AXLE ASSEMBLIES

SPECIFICATIONS

Suspension:

Leaf Spring Suspension:

- Mounted 2 1/2" Wide Slipper Eye, Bronze 7/8" ID or 3/4" ID Rubber Bushing (Spring Kits sold separately.)

Adjustable Spring Seat: For tracking alignment (optional).

Hanger Kit Options: See table below (sold separately).

Bolt Pattern Options:

- 8 on 6 1/2", 4.75 Pilot

Brake Options: (Forward Self-Adjusting)

- 12 1/4" x 3 3/8" Electric
- 12 1/4" x 3 3/8" Hydraulic - Uni or Duo-Servo, Parking feature available with Duo-Servo only.
- ABS Equipped option for Hydraulic Brakes

Spindles: Uses 387A Inner, 25580 Outer Bearing

- Straight*

Tubing:

- 5" OD

Lubrications:

- Oil Bath

Wheel Assemblies:

See Section E

Replacement Parts

Hub/Drums: See Page B-26 - B-27

Brakes: See Page C-12 (Electric)
See Page C-26 (Hydraulic)

Axle Beams: See Page B-1

10,000 LB. AXLE ASSEMBLIES

Axle Type	8 on 6 1/2"
ELECTRIC	10GD865E-NOSPR
DUO-SERVO HYDRAULIC	10GD865HY-NOSPR
ABS Equipped	8 on 6 1/2"
ELECTRIC	N/A
DUO-SERVO HYDRAULIC	10GD865HABSNSPR

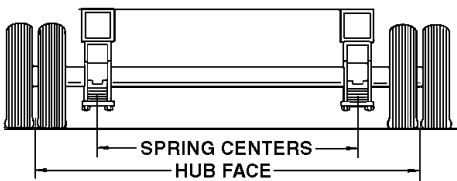

DIFFERENCE BETWEEN HUB FACE*/TRACK WIDTH* AND SPRING CENTER

Wheel	Minimum	Maximum
SINGLE (HF)	23.50	31.00
DUAL (TW)	26.00	31.00

*Hubface (HF) used to specify applications using single wheels.
*Track Width (TW) uses to specify applications using dual wheels.

NOTE: Dimensions are based on manufacturing tolerances only. Some tire and wheel combinations may create interference.

*Axle Replacements for axles before July 27, 2009 must specify "OLD STYLE" Spindle.

10,000 LB. GENERAL DUTY AXLE OPTION

Part No.	Ref. No.	Description
10GHYD-PARK	032410	HYDRAULIC BRAKES W/PARK, ADD TO 10K GD HYDRAULIC BRAKE AXLE
10GDADJ-SEAT	032430	ADJ SPG SEATS ALLOWS CORRECTION OF AXLE SPACING, PREVENTS SIDE TRACKING
SHORT-HF-10GD	032435	EXTRA CHARGE PER AXLE, 10GD AXLES UNDER 48" HF
EXTRM-HF-10GD	032440	EXTRA CHARGE PER AXLE, 10GD AXLES OVER 97" HF
2-72-77	032601	2 EA., 72-77 SPRINGS MTD ON ABOVE 10K GD AXLES (7/8" SPRING EYE)
2-72-80	032605	2 EA., 72-80 SPRINGS MTD ON ABOVE 10K GD AXLES (3/4" SPRING EYE, RUBBER BUSHED)

Hanger and Attaching Parts Kits for 9,000 lb. (Sold Separately)

SEE CATALOG PAGES D-XXXX FOR SUSPENSION OPTIONS



10,000 lb Heavy Duty

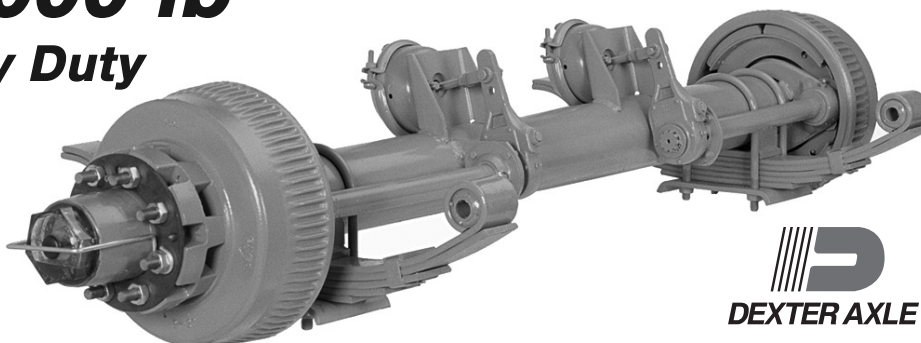

SPECIFICATIONS

Suspension:

Leaf Spring Suspension:

- Mounted 3" Wide Slipper Eye, Rubber Bushing (Spring Kits sold separately)

Adjustable Spring Seat: For tracking alignment (optional)

Hanger Kit Options: (sold separately)

Bolt Pattern Options:

- 8 on 6 1/2", 4.75 Pilot

Brake Options:

- 12 1/4" x 4" Electric - Forward Self-Adjusting
- 12 1/4" x 4" Hydraulic - Forward Self-Adjusting, Uni or Duo-Servo, Parking feature available
- Hydraulic Disc
- Air Brakes - Manual Slack Adjusters (standard), Automatic Slack Adjusters (optional)
- ABS Equipped option for Hydraulic Brakes

Spindles: Uses 387A Inner, 25580 Outer Bearing

- Straight

Tubing:

- 5" OD • Optional HVY wall for use w/Air-Ride Suspension

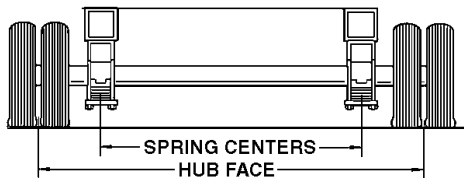

NOTE: Dimensions are based on manufacturing tolerances only. Some tire and wheel combinations may create interference.

Lubrications:

- Oil Bath

Wheel Assemblies:

See Section E

Replacement Parts

Hub/Rotor: See Page B-28

Hub/Drums: See Page B-27

Brakes: See Page C-14 (Electric), C-27 (Hyd.)
C-29 (Hyd. Disc), C-30 (Air)

Axle Beams: See Page B-1

10,000 LB. AXLE ASSEMBLIES

Axle Type	8 on 6 1/2"
ELECTRIC	10K865E-NOSPR
HYDRAULIC	10K865HY-NOSPR
HYDRAULIC DISC	10K865DS-NOSPR
AIR BRAKE	10K865A-NOSPR
AIR BRAKE W/PARK	10K865ASB-NOSPR
ABS Equipped	8 on 6 1/2"
ELECTRIC	N/A
HYDRAULIC	10K865HABS-NOSPR
HYDRAULIC DISC	10K865DABS-NOSPR
AIR BRAKE	10K8A-ABS-NOSPR
AIR BRAKE W/PARK	10K8APABS-NOSPR

DIFFERENCE BETWEEN HUB FACE*/TRACK WIDTH* AND SPRING CENTER

Wheel	Minimum	Maximum
SINGLE (HF)	25.38	31.00
DUAL (TW)	26.00	31.00

*Hubface (HF) used to specify applications using single wheels.

*Track Width (TW) uses to specify applications using dual wheels.

10,000 LB. HEAVY DUTY AXLE OPTIONS

Part No.	Ref. No.	Description
ADD-10KHD-WALL	035250	ADD PER AXLE FOR HVY WALL TUBING (REQUIRED FOR AIR RIDE SUSPENSION)
SHORT-HF-10K	035255	EXTRA CHARGE PER AXLE, 10K AXLES UNDER 48" HF
EXTRM-HF-10K	035260	EXTRA CHARGE PER AXLE, 10K AXLES OVER 97" HF
10KHYD-PARK	035400	HYDRAULIC BRAKES W/ PARK, ADD TO 10K HEAVY DUTY AXLE
10KADJ-SEAT	035450	ADJ SPG SEATS ALLOWS CORRECTION OF AXLE SPACING, PREVENTS SIDE TRACKING
ADD-AUTOSL	043125	ADD PER AXLE FOR AUTOMATIC SLACK ADJUSTERS (AIR BRAKE)
2-72-43-1	040700	2 EA., 72-43-1 SPRINGS FOR ABOVE 10K AXLES



12,000 lb Heavy Duty



AXLE ASSEMBLIES

SPECIFICATIONS

Suspension:

Leaf Spring Suspension:

- Mounted 3" Wide Slipper Eye, Rubber Bushing (Spring Kits sold separately)

Adjustable Spring Seat: For tracking alignment (optional)

Hanger Kit Options: (sold separately)

Bolt Pattern Options:

- 8 on 6 1/2", 4.75 Pilot

Standard: Hi Profile Hub for 16", 16.5" dia. wheels

Optional: Low Profile for 14.5" wheels

Brake Options:

- 12 1/4" x 5" Electric - Forward Self-Adjusting
- 12 1/4" x 5" Hydraulic - Forward Self-Adjusting, Uni or Duo-Servo, Parking feature available w/ Duo-Servor Only
- Hydraulic Disc
- Air Brakes - Manual Slack Adjusters (standard), Automatic Slack Adjusters (optional)
- ABS Equipped option for Hyd, Disc, & Air Brake

Spindles: Uses 3984 Inner, 28682 Outer Bearing

- Straight

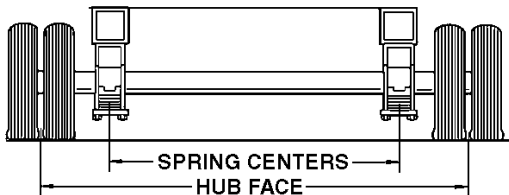

NOTE: Dimensions are based on manufacturing tolerances only. Some tire and wheel combinations may create interference.

Tubing: Lubrications: Wheel Assemblies:

- 5" OD
- Oil Bath
- See Section E

Replacement Parts

Hub/Rotor: See Page B-29

Hub/Drums: See Page B-29

Brakes: See Page C-15 (Elec.), C-28 (Hyd.)
C-29 (Hyd. Disc), C-30 (Air)

12,000 LB. HEAVY DUTY AXLE ASSEMBLIES

8 on 6 1/2"	High Profile	Low Profile
ELECTRIC	12K865E-NOSPR	12K865LPE-NOSPR
HYDRAULIC DISC	12K865DS-NOSPR	N/A
DUO-SERVO HYDRAULIC	12K865HY-NOSPR	12K865LPHY-NSPR
AIR BRAKE	12K865A-NOSPR	12K865LPA-NSPR
AIR BRAKE W/PARK	12K865ASB-NOSPR	12K865LPASBNOSP
ABS Equipped, 8 on 6 1/2"		
ELECTRIC	N/A	N/A
HYDRAULIC DISC	12K865DABS-NSPR	N/A
DUO-SERVO HYDRAULIC	12K865HABS-NSPR	12K8LPHABS-NSPR
AIR BRAKE	12K8A-ABS-NSPR	12K8ALPABS-NSPR
AIR BRAKE W/PARK	12K8APABS-NOSPR	12K8LAPABSNSP

DIFFERENCE BETWEEN HUB FACE*/TRACK WIDTH* AND SPRING CENTER

Wheel	Minimum	Maximum
LOW/SINGLE (HF)	32.74	41.00
LOW/DUAL (TW)	33.50	41.00
HIGH/SINGLE (HF)	25.88	41.00
HIGH/DUAL (TW)	26.50	41.00

*Hubface (HF) used to specify applications using single wheels.

*Track Width (TW) uses to specify applications using dual wheels.

12,000 LB. HEAVY DUTY AXLE OPTIONS

Part No.	Ref. No.	Description
SHORT-HF-12K	037120	EXTRA CHARGE PER AXLE, 12K AXLES UNDER 48" HF
EXTRA-HF-12K	037125	EXTRA CHARGE PER AXLE, 12K AXLES OVER 97" HF
12KHYD-PARK	037200	HYDRAULIC BRAKES W/PARK, ADD TO 12K HEAVY DUTY AXLE
12KADJ-SEAT	037250	ADJ SPG SEATS ALLOWS CORRECTION OF AXLE SPACING, PREVENTS SIDE TRACKING
ADD-AUTOSL	043125	ADD PER AXLE FOR AUTOMATIC SLACK ADJUSTERS (AIR BRAKE)
2-72-44-1	040740	2 EA., 72-44-1 SPRINGS FOR ABOVE 12K AXLES



15,000 lb Heavy Duty



SPECIFICATIONS

Suspension:

Leaf Spring Suspension:

- Mounted 3" Wide Slipper Eye, Rubber Bushing (Spring Kits sold separately)

Adjustable Spring Seat: For tracking alignment (optional)

Hanger Kit Options: (sold separately)

Bolt Pattern Options:

- 8 on 275mm Hub-Piloted

Brake Options:

- 12 1/4" x 5" Electric - Forward Self-Adjusting
- 12 1/4" x 5" Hydraulic - Forward Self-Adjusting, Duo-Servo, Parking feature available
- Air Brakes - Manual Slack Adjusters (standard), Automatic Slack Adjusters (optional)
- ABS Equipped for Hydraulic and Air Brakes

Spindles: Uses 3984 Inner, 28682 Outer Bearing

- Straight

Tubeing: Lubrications: Wheel Assemblies:

- 5" OD • Oil Bath See Section E

Replacement Parts

Hub/Drums: See Page B-30

Brakes: See Page C-15 (Electric),
C-28 (Hydraulic), C-30 (Air)

15,000 LB. HEAVY DUTY AXLE ASSEMBLIES

Axle Type	8 on 275mm
ELECTRIC	15K8E-NOSPR
DUO-SERVO HYDRAULIC	15K8HY-NOSPR
AIR BRAKE	15K8A-NOSPR
AIR BRAKE W/SPRING BRAKES	15K8ASB-NOSPR
ABS Equipped	8 on 275mm
ELECTRIC	N/A
DUO-SERVO HYDRAULIC	15K8HABS-NOSPR
AIR BRAKE	15K8AABS-NOSPR
AIR BRAKE W/SPRING BRAKES	15K8APABS-NSPR

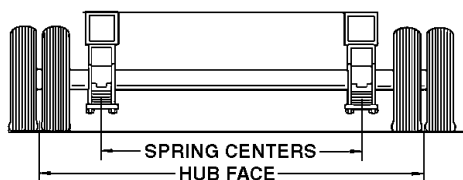

DIFFERENCE BETWEEN HUB FACE*/TRACK WIDTH* AND SPRING CENTER

Wheel	Minimum	Maximum
SINGLE (HF)	28.12	33.00
DUAL (TW)	29.00	33.00

*Hubface (HF) used to specify applications using single wheels.

*Track Width (TW) uses to specify applications using dual wheels.

NOTE: Dimensions are based on manufacturing tolerances only. Some tire and wheel combinations may create interference.

15,000 LB. HEAVY DUTY AXLE OPTIONS

Part No.	Ref. No.	Description
15KHYP-PARK	040600	HYDRAULIC BRAKES W/PARK, ADD TO 15K HYD BRAKE AXLE PRICE
SHORT-HF-15K	040605	EXTRA CHARGE PER AXLE, 15K AXLES UNDER 48" HF
XTRA-HF-15K	040610	EXTRA CHARGE (PER AXLE) FOR 15K AXLES WITH OVER 80" HUB FACE THROUGH 97" HF
EXTRM-HF-15K	040611	EXTRA CHARGE PER AXLE, 15K AXLES OVER 97" HF
15KADJ-SEAT	040615	ADJ SPG SEATS ALLOWS CORRECTION OF AXLE SPACING, PREVENTS SIDE TRACKING
2-72-45-1	040770	2 EA., 72-45-1 SPRINGS MTD ON ABOVE 15K AXLES
ADD-AUTOSL	043125	ADD PER AXLE FOR AUTOMATIC SLACK ADJUSTERS (AIR BRAKE)



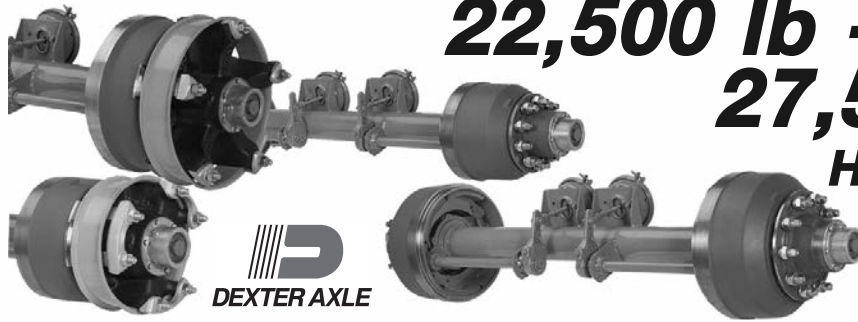

22,500 lb - 27,500 lb Heavy Duty



AXLE ASSEMBLIES

SPECIFICATIONS

Suspension: See pages D-XXX and DXX for listing

Bolt Pattern Options: • 3 Spoke Cast • 5 Spoke Cast
Hub-Piloted Flange Nut: • 8 on 275mm • 10 on 285.75mm
2-Piece Wheel Nut: • 10 on 8 3/4" • 10 on 11 1/4"

Brake Options: • 12 1/4" x 7 1/2" "S" Cam Air Brakes
• 16 1/2" x 7" "S" Cam Air Brakes • Spring Brakes* &/or
ABS Equipped* Axles available upon request

Cam Shaft: Various lengths are available upon request*

Slack Adjusters: Available in Manual, Automatic* and/or
Curved* models.

Spindles: HM218248 Inner, HM212049 Outer Bearing

Air Chambers: Type 30 Service Chamber Standard

Spring Brakes: Available upon request

Seals: Unitized National or Stemco* Seals

*Indicates those parts which are optional features and an additional charge from the standard models.

Track: 71 1/2" and 77 1/2"* standard (*special tracks available upon request) Note: Axle tracks under 71" may be subject to clearance problems when used w/ air-ride suspensions

Tube/Beam Capacity: 5" OD x LT wall (22,500lb), MED wall (25,000 lb), HVY wall (27,500 lb), Capacities reduced in off-road and/or Air-Ride suspensions applications. A minimum of MED wall thickness required for Air-Ride Suspensions.

Spring Centers:

Maximum: Track minus 32 1/2" or as tire clearance allows

Minimum: Track minus 34 1/2"

Replacement Parts

Brakes: See Page C-30 (Air)

HEAVY DUTY AXLE ASSEMBLIES

Axle Type	LT Wall Thickness	MED Wall Thickness	HVY Wall Thickness
12 1/4" x 7 1/2" Brake			
LESS HUB AND DRUM	D200-5-LHD12	D200-6-LHD12	D200-7-LHD12
3 SPOKE CAST HUB & DRUM FOR 17.5" RIMS	D200-5-3SPK12	D200-6-3SPK12	D200-7-3SPK12
3 SPOKE CAST HUB & DRUM FOR 17.5" RIMS, W/ABS SENSORS & TONE RINGS	D200-5-3SP12ABS	D200-6-3SP12ABS	D200-7-3SP12ABS
8 ON 275MM BOLT CIRCLE HUB & DRUM	D200-5-8-12	D200-6-8-12	D200-7-8-12
8 ON 275MM BOLT CIRCLE HUB & DRUM, W/ABS SENSOR & TONE RINGS	D200-5-8-12ABS	D200-6-8-12ABS	D200-7-8-12ABS
10 ON 8 3/4" BOLT CIRCLE HUB AND DRUM	D200-5-10-12	D200-6-10-12	D200-7-10-12
10 ON 8 3/4" BOLT CIRCLE HUB AND DRUM, W/ABS SENSOR & TONE RINGS	D200-5-10-12ABS	D200-6-10-12ABS	D200-7-10-12ABS
16 1/2" x 7" Brake			
LESS HUB AND DRUM	D200-5-LHD16	D200-6-LHD16	D200-7-LHD16
5 SPOKE CAST HUB & DRUM FOR 22.5" RIMS,	D200-5-5SPK16	D200-6-5SPK16	D200-7-5SPK16
5 SPOKE CAST HUB & DRUM FOR 22.5" RIMS, W/ABS SENSORS & TONE RINGS	D200-5-5SP16ABS	D200-6-5SP16ABS	D200-7-5SP16ABS
10 ON 11 1/4" BOLT CIRCLE HUB & DRUM	D200-5-10-16	D200-6-10-16	D200-7-10-16
10 ON 11 1/4" BOLT CIRCLE HUB AND OUTBOARD DRUM	D200-5-10-16OB	D200-6-10-16OB	D200-7-10-16OB
10 ON 11 1/4" BOLT CIRCLE HUB AND OUTBOARD DRUM, W/ABS SENSOR & TONE RINGS	D200-5-10-16ABS	D200-6-10-16ABS	D200-7-10-16ABS

22,500 - 27,500 LB. HEAVY DUTY AXLE OPTIONS

Part No.	Ref. No.	Description
D200-16-ADD-HPS	042066	HUB PILOTED OPTION, ADDON TO D200 16" 10-11.25" OUTBOARD DRUM (10-285.75MM)
SHORT-HF-20K	042068	EXTRA CHARGE (PER AXLE) FOR D200 UNDER 48" TRACK
XTRA-HF-20K	042070	EXTRA CHARGE (PER AXLE) FOR D200 W/TRACK 71.6" - 77.5"
XTRAWD-HF-20K	042072	EXTRA CHARGE (PER AXLE) FOR D200 W/TRACK 77.6" - 92.5"
SUPRWD-HF-20K	042100	EXTRA CHARGE (PER AXLE) FOR D200 W/TRACK 92.6" - 124"
EXTRM-HF-20K	042105	EXTRA CHARGE (PER AXLE) FOR D200 OVER 124" TRACK
ADD-STEMCO	043075	STEMCO VOYAGER SEAL OPT, ADD-ON FOR D200 AXLES
ADD-3030SB	043100	T3030 SPRING BRAKE OPTION FOR D200 AXLES
ADD-AUTOSL	043125	CREWSON AUTOSLK OPT. FOR 10K THRU D200 AIR BRAKE AXLES



AXLE MEASUREMENTS

LEAF SPRING SUSPENSION AXLES

Hubface - Track Width - Spring Center

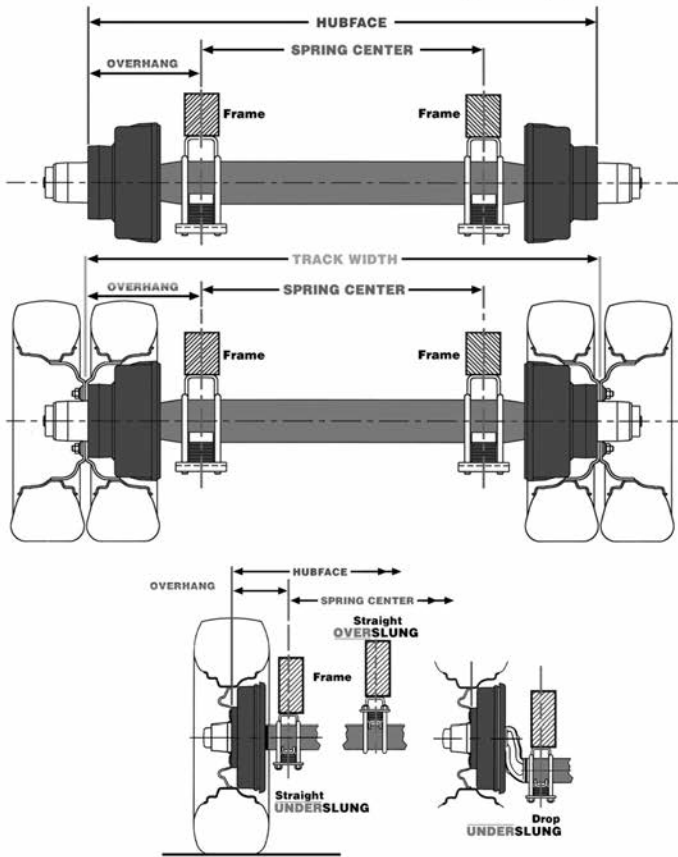

Wheel Offset

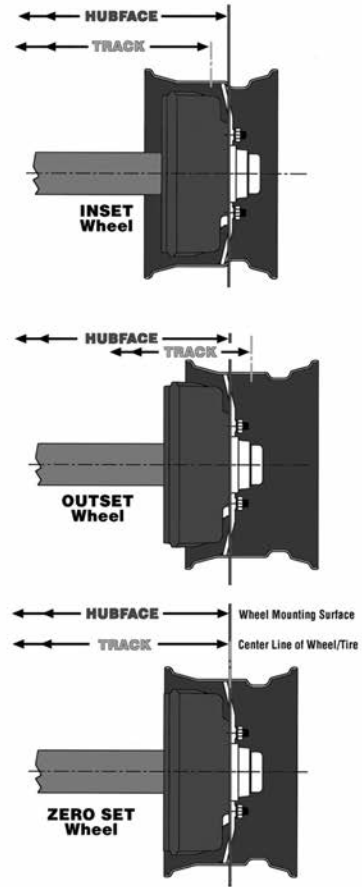

Spring Position

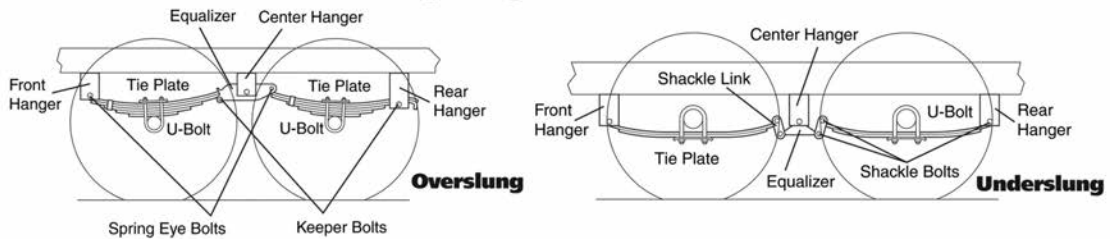

Axle Spacing

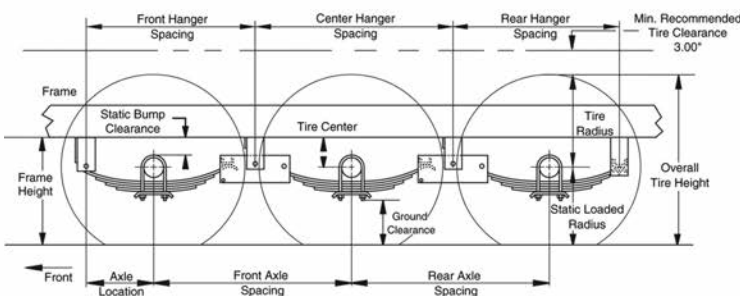

Spring Type

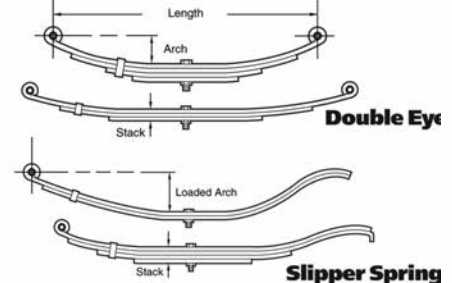

These charts and diagrams are for illustration purposes only. For additional details on installation, please consult Dexter Axle's Applications Manual.

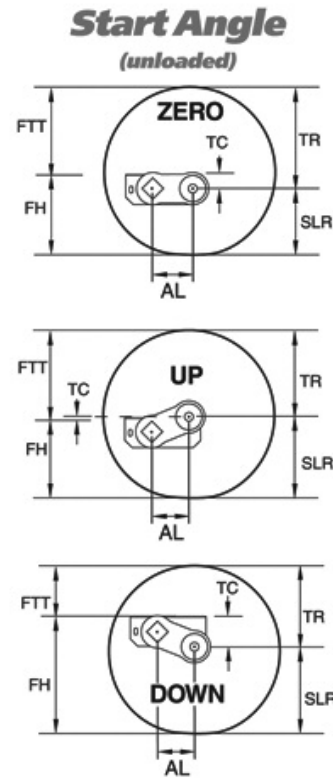
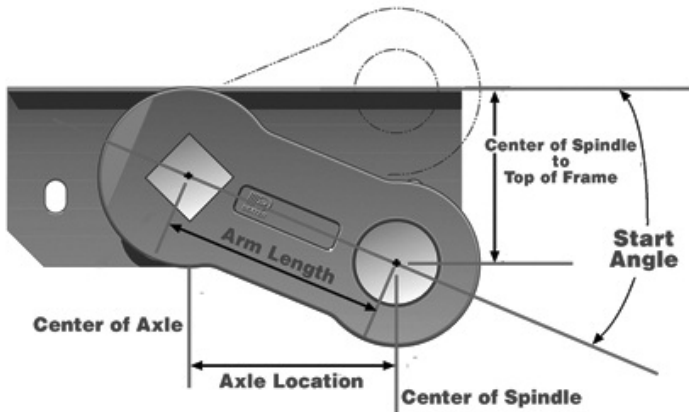
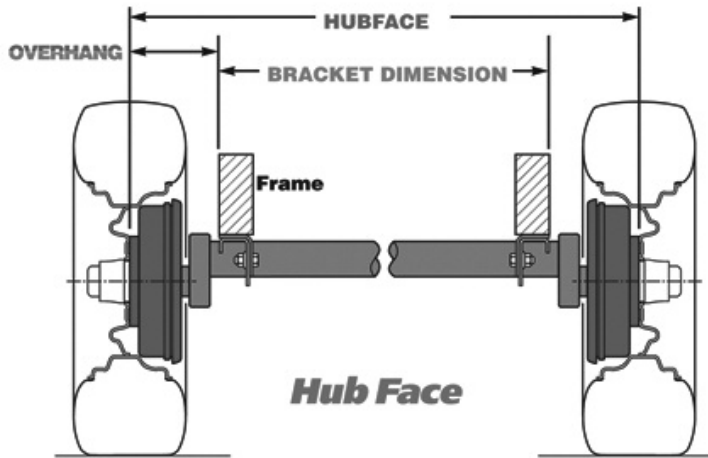

FTT = Frame to Top of Trailer
 FH = Frame Height
 TC = Tire Center
 AL = Axle Location
 TR = Tire Radius
 SLR = Static Load Radius

Bracket Profile

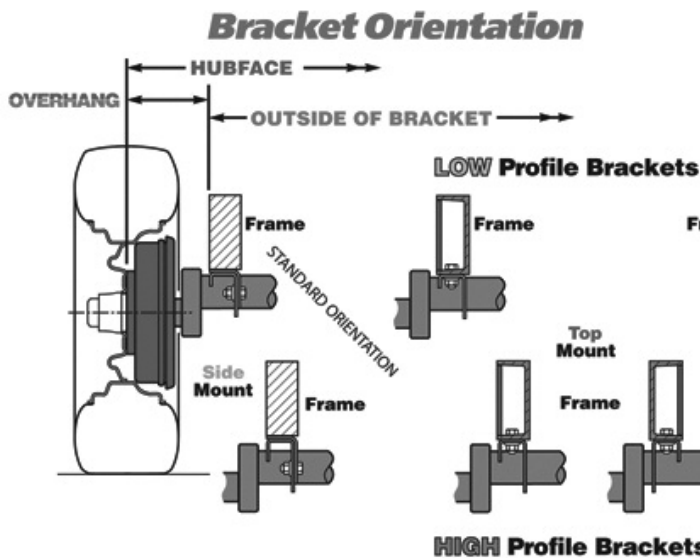
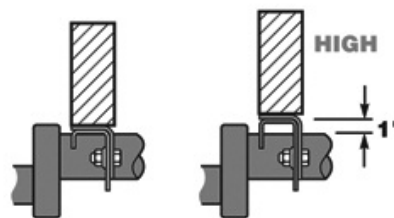

These charts and diagrams are for illustration purposes only. For additional details on installation, please consult Dexter Axle's Applications Manual.



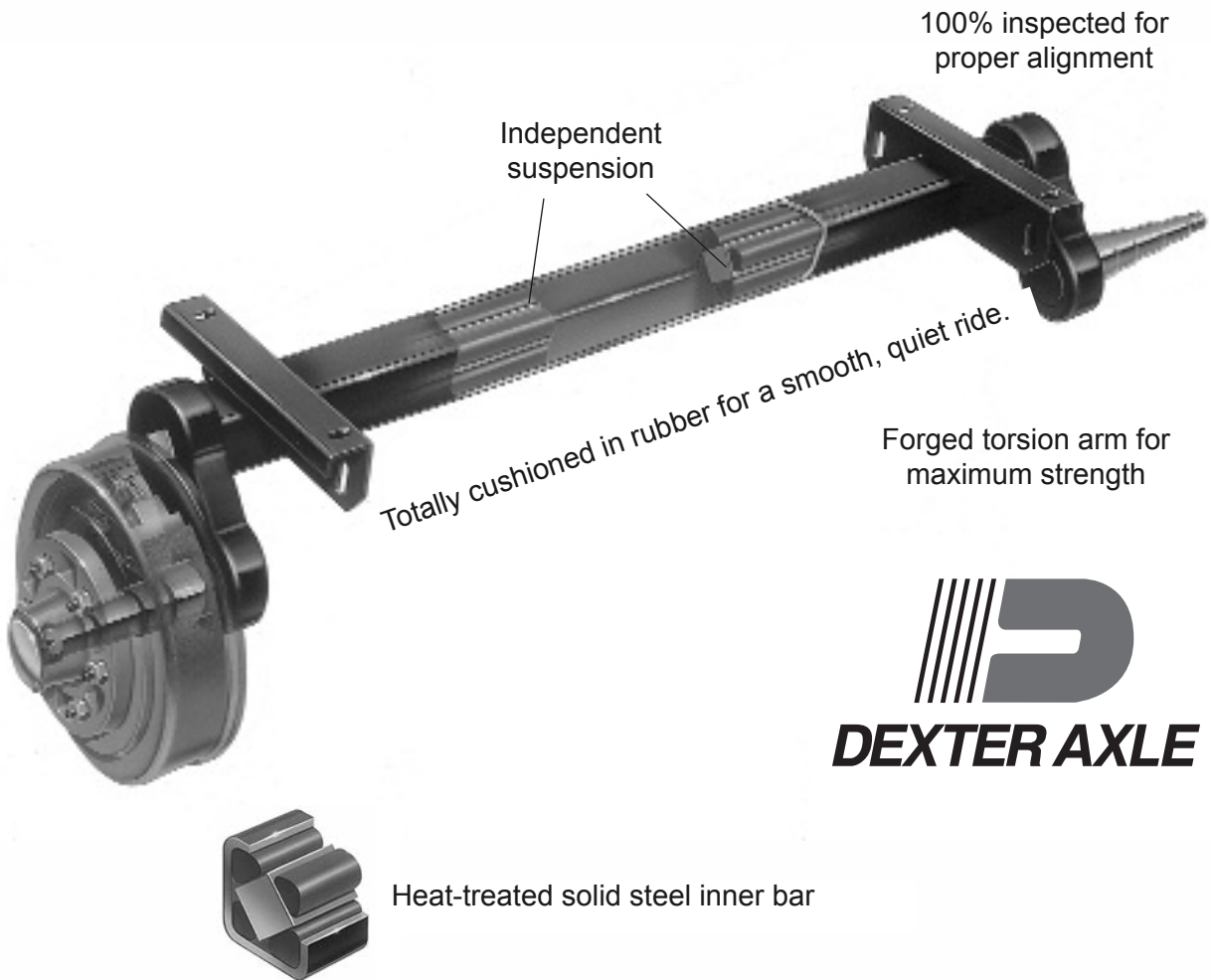

- Independent wheel suspension
- Maximum stability
- Low profile with maximum road clearance
- Installs easily
- Components with high resistance to wear
- Five year warranty on suspension systems
- 600 lb. - 10,000 lb. capacities, tailored for your requirements
- Axle can be used as a cross member
- Bearing lubrication options: Standard grease, E-Z Lube™, Nev-R-Lube™ or Oil (7,000 lb. and above)

CAUTION: Triple Axle Assemblies are NOT recommended for Torflex® Axles.



HOW TO SELECT TORFLEX® AXLES:



1. How to Determine the Gross Vehicle Weight (GVW)

When building a trailer, the total Gross Vehicle Weight (GVW) must be determined in order to select the right axle or axles for the application. GVW includes the weight of the empty trailer and the weight of the intended cargo. (Example: 2,000 lb. empty trailer weight + 8,000 lbs. cargo = GVW of 10,000 lbs.)

2. How Many Axles?

After determining the GVW, you must then determine the % of that weight to be on the axles (GAW). The number and capacity of the axles must be selected. For example, if you have 10,000 lb. GAW and want tandem axles, the minimum required capacity is 5,000 lbs. per axle.



3. Brakes?

First, determine if you want brakes. Most states require by law that trailers of specific capacity requires brakes. To determine brake requirements in a state, contact the local Department of Motor Vehicles. Second, determine what type of brake you prefer: Electric, Hydraulic Uni-Servo, Hydraulic Free-Backing, Hydraulic Duo-Servo, Hydraulic Disc or Air "S" Cam Brakes.

4. What is the Length of the Axle?

Of the several ways and industry terms to describe this procedure, the most popular term is "Hub Face" which is the measurement from the base of the wheel stud to the base of the wheel stud on the opposite end of the axle.

5. Which Bolt Pattern?

The Bolt Pattern of the axles can vary depending on the capacity of the axle. The Bolt Pattern also determines what type tire and wheel can be used. If there is a specific tire and wheel you would like to use, please relay that information so we can help you to determine the proper bolt pattern and axle.

6. What is the Outside Frame Dimension?

Since the mounting brackets of the Torflex® axles mount directly to the frame of your trailer, it is necessary to know the outside frame measurement in order to install them on the axle correctly.

7. How to Determine the Trailing Arm Starting Angle

The starting angle is the position of the spindle in reference to the trailer frame. In order to make it simpler to select the starting angle for your Torflex® axle, consult the tables which appear at the bottom of each Torflex® axle page.

HOW TO ORDER TORFLEX® AXLES:

Our part numbers for Torflex Axles is very similar to that of the tubular axles.

Please place your order according to the description based on the following information/example:

EX: 12TF70-865E-EZ: #12 Torflex, 7,000 lb., 8 Bolt, 6.5" Bolt Pattern, Electric Brake, E-Z Lube®

12TF: Model of Torflex® Axle (#8, #9, #10, #11, #12, #12V, #13, #13G, #13D)

70: Capacity of Torflex® Axle (70 = 7,000 lb. capacity)

865: 8 Bolt, 6.5" Bolt Pattern

E: Type of Brake, if any (I = Idler, E = Electric, H = Uno-Servo Hydraulic, HY = Duo-Servo Hydraulic, DS = Disc)

EZ: Type of Lube (EZ = E-Z Lube®, NL = Nev-R-Lube®, OIL = Oil)

It is also necessary that you give us the outside dimension of your frame and the starting angle of the trailing arm.



600 lb. - 1,100 lb.
#8 TORFLEX®
 RUBBER TORSION SUSPENSION AXLES



SPECIFICATIONS

Suspension:

Features an independent suspension cushioned with rubber, providing a smooth, quiet ride with no transfer of road shock from one wheel to the other. (No springs required)

Bolt Pattern Options:

- 4 on 4"
- 5 on 4.5"

5 Bolt available with:

- 5 1/2" Hub Flange – For 8" - 12" Wheels
- 6 1/2" Hub Flange – For 13" - 15" Wheels

Brake Options:

- Electric & Hydraulic Uni-Servo

Lubrications:

- Grease
- E-Z Lube®

Spindles:

Standard BTR 1 1/16", L44649 Inner/Outer Bearings.

Tubing:

- 1.75" OD Square

Wheel Assemblies: See Section E

Replacement Parts

Idler Hub: See Page B-10 - B-11

Hub/Drums: See Page B-16 - B-17

Brakes: See Page C-7 (Elec.), C-21 (Hyd.)

Axle Beams: See Page B-1

#8 TORFLEX® AXLE ASSEMBLIES

Axle Type	4 on 4"	5 on 4 1/2"
IDLER	8TF9-440I	8TF9-545I
IDLER W/E-Z LUBE®	8TF9-440I-EZ	8TF9-545I-EZ

#8 TORFLEX® MOUNTING KIT & AXLE OPTIONS

Part No.	Ref. No.	Description
XTRA-HF-8TF	044825	EXTRA CHARGE (PER AXLE) FOR AXLES OVER 96" HUB FACE
AP165	046910	WELD ON MOUNTING KIT FOR #8 & #9 TORFLEX AXLES (STEEL)
AP180	046915	WELD ON MOUNTING KIT FOR #8 & #9 TORFLEX AXLES (ALUM)



#8 TORFLEX® SPECIFICATIONS



Mounting Details

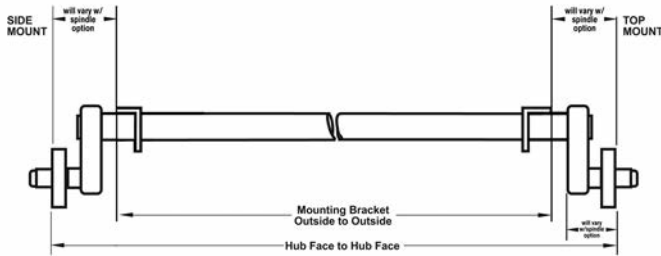

Difference between hubface and outside mounting brackets

Minimum

9.50" (4.75" per side) Ilders only
12.00" (6.00" per side) with brakes

Maximum

18.08" (9.04" per side)

Note: Minimums are based on manufacturing tolerances only. Some tire and wheel combinations may create interference.



Full Load Dimensions

Dimensions are for low profile, top mount only. Side mount is .18" higher. Allow 3" bump clearance from full load.

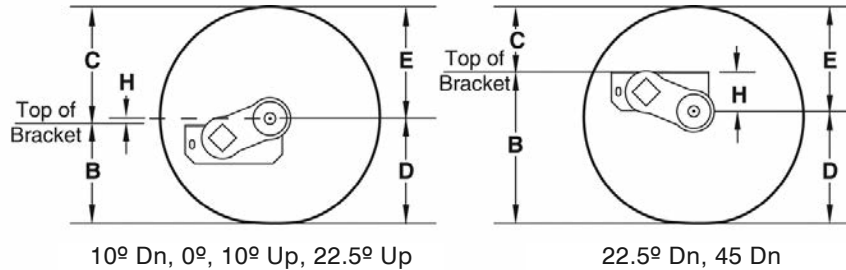

H = Center Line of spindle to top of bracket, B = Top of bracket to ground, C = Top of bracket to top of tire, D = Center Line of spindle to ground, E = Center Line of spindle to top of tire.

START ANGLE

Tire	45° Down			22.5° Down			10° Down			0°			10° Up			22.5° Up			D	E
	H	B	C	H	B	C	H	B	C	H	B	C	H	B	C	H	B	C		
ST175/80R13	2.5	13.7	9.5	1.0	12.2	11.0	0.1	11.3	11.9	-0.5	10.7	12.5	-1.1	10.1	13.1	-1.8	9.4	13.8	11.2	12.0
4.80-8	2.5	10.4	6.3	1.0	8.9	7.8	0.1	8.0	8.7	-0.5	7.4	9.3	-1.1	6.8	9.9	-1.8	6.1	10.6	7.9	8.8
4.80-12	2.5	12.0	8.3	1.0	10.5	9.8	0.1	9.6	10.7	-0.5	9.0	11.3	-1.1	8.4	11.9	-1.8	7.7	12.6	9.5	10.8
20.5x8.0-10	2.5	12.2	8.3	1.0	10.7	9.8	0.1	9.8	10.7	-0.5	9.2	11.3	-1.1	8.6	11.9	-1.8	7.9	12.6	9.7	10.8

ARTICULATION DIMENSIONS

ALLOW 3" BUMP CLEARANCE FROM FULL LOAD.

Positive numbers indicate spindle is below the top of the bracket, negative numbers are above.

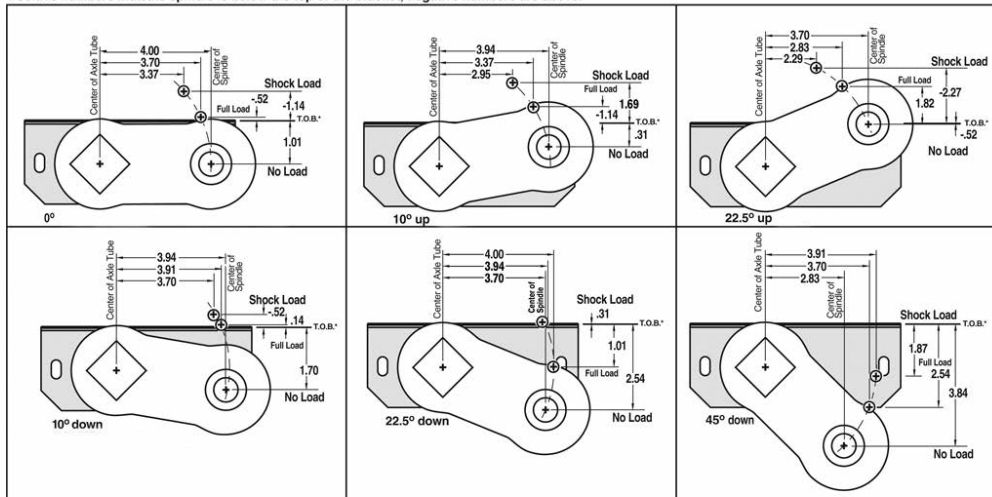

* TOP OF BRACKET



1,000 lb. - 2,200 lb.
#9 TORFLEX®
 RUBBER TORSION SUSPENSION AXLES



SPECIFICATIONS

Suspension:

Features an independent suspension cushioned with rubber, providing a smooth, quiet ride with no transfer of road shock from one wheel to the other. (No springs required)

Bolt Pattern Options:

- 4 on 4"
- 5 on 4.5"

5 Bolt available with:

- 5 1/2" Hub Flange – For 8" - 12" Wheels
- 6 1/2" Hub Flange – For 13" - 15" Wheels

Brake Options:

- 7" x 1 1/4" - Electric
- 7" x 1 3/4" - Hydraulic Uni-Servo

Lubrications:

- Grease
- E-Z Lube®

Spindles:

Standard BTR 1 1/16", L44649 Inner/Outer Bearings.

Tubing:

- 2.17" OD Square

Wheel Assemblies: See Section E

Replacement Parts

Idler Hub: See Page B-10 - B-11

Hub/Drums: See Page B-16 - B-17

Brakes: See Page C-7 (Elec.), C-21 (Hyd.)

Axle Beams: See Page B-1

#9 TORFLEX® AXLE ASSEMBLIES

Axle Type	4 on 4"	5 on 4 1/2"
IDLER	9TF20-440I	9TF20-545I
IDLER W/E-Z LUBE®	9TF20-440I-EZ	9TF20-545I-EZ
ELECTRIC	9TF20-440E	9TF20-545E
ELECTRIC W/E-Z LUBE®	9TF20-440E-EZ	9TF20-545E-EZ
UNI-SERVO HYDRAULIC	9TF20-440H	9TF20-545H
HYDRAULIC W/E-Z LUBE®	9TF20-440H-EZ	9TF20-545H-EZ

#9 TORFLEX® MOUNTING KIT & AXLE OPTIONS

Part No.	Ref. No.	Description
XTRA-HF-9TF	046825	EXTRA CHARGE (PER AXLE) FOR AXLES OVER 96" HUB FACE
AP165	046910	WELD ON MOUNTING KIT FOR #8 & #9 TORFLEX® AXLES (STEEL)
AP180	046915	WELD ON MOUNTING KIT FOR #9 TORFLEX® AXLES (ALUM)



#9 TORFLEX® SPECIFICATIONS



Mounting Details

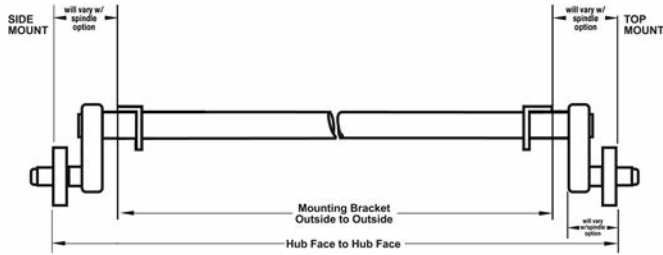

Difference between hubface and outside mounting brackets

Minimum

Short 12.00" (6" per side)
Standard 13.00" (6.50" per side)

Maximum

21.80" (10.9" per side)

Note: Minimums are based on manufacturing tolerances only. Some tire and wheel combinations may create interference.



Full Load Dimensions

Dimensions are for low profile, top mount only. High-Profile Bracket Option adds .88" higher. Side mount is .18" higher. Allow 3" bump clearance from full load.

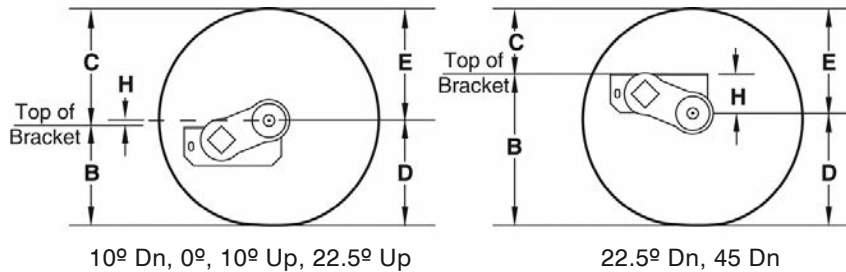

H = Center Line of spindle to top of bracket, **B** = Top of bracket to ground, **C** = Top of bracket to top of tire, **D** = Center Line of spindle to ground, **E** = Center Line of spindle to top of tire.

START ANGLE

Tire	45° Down			22.5° Down			10° Down			0°			10° Up			22.5° Up			D	E
	H	B	C	H	B	C	H	B	C	H	B	C	H	B	C	H	B	C		
ST175/80R13	3.5	14.7	8.5	1.2	12.4	10.8	-0.1	11.1	12.1	-1.1	10.1	13.1	-2.0	9.2	14.0	-3.0	8.2	15.0	11.2	12.0
4.80-8	3.5	11.4	5.3	1.2	9.1	7.6	-0.1	7.8	8.9	-1.1	6.8	9.9	-2.0	5.9	10.8	-3.0	4.9	11.8	7.9	8.8
4.80-12	3.5	13.0	7.3	1.2	10.7	10.9	-0.1	9.4	10.9	-1.1	8.4	11.9	-2.0	7.5	12.8	-3.0	6.5	13.8	9.5	10.8
20.5x8.0-10	3.5	13.2	7.3	1.2	10.9	10.9	-0.1	9.6	10.9	-1.1	8.6	11.9	-2.0	7.7	12.8	-3.0	6.7	13.8	9.7	10.8

ARTICULATION DIMENSIONS

ALLOW 3" BUMP CLEARANCE FROM FULL LOAD.
Positive numbers indicate spindle is below the top of the bracket, negative numbers are above.

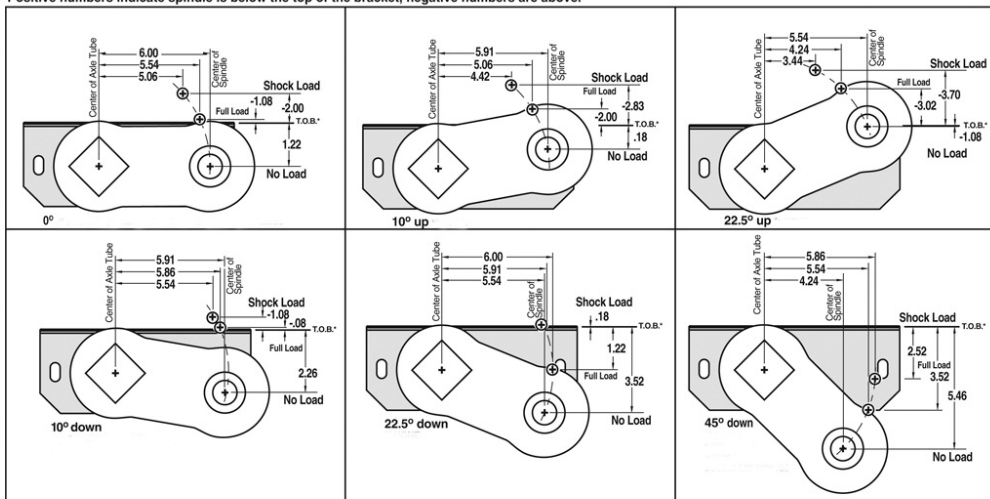



SPECIFICATIONS

Suspension:

Features an independent suspension cushioned with rubber, providing a smooth, quiet ride with no transfer of road shock from one wheel to the other. (No springs required)

Bolt Pattern Options:

- 5 on 4 1/2" • 5 on 4.5" • 5 on 5"
- 5 on 5 1/2" • 6 on 5 1/2"

Tubeing:

- 2.62" OD Square

Brake Options:

- 10 x 2 1/4" Electric (Manual or Nev-R-Adjust®)
- 10 x 2 1/4" Hydraulic (Uni, Duo-Servo & Freebacking)
- 10 x 2 1/4" Hyd Freebacking Corrosion Resistant (Galv/Marine Axle)
- Hydraulic Disc: 5 on 4 1/2" only

Lubrications:

- Grease • E-Z Lube® • Nev-R-Lube®

Spindles:

TTH (#84 Spindle)
L68149 Inner, L44649 Outer Bearings

- Stainless Steel Wear Sleeves on Galvanized Axles

Beams/Options:

- Galvanized Option (Marine) w/GAL-DEX™ Corrosion Resistant Hubs
- V-Bend Beam Option (Marine)

Wheel Assemblies:

See Section E

Replacement Parts

Idler Hub: See Page B-12

Hub/Drums: See Page B-18 - B-19, B-31 (Nev-R-Lube)

Hub/Rotor: See Page B-33

Brakes: See Page C-8 (Electric), C-22 (Hyd. Drum), B-33 (Hyd. Disc)

Axle Beams: See Page B-1

#10 TORFLEX® AXLE ASSEMBLIES

Axle Type	5 on 4 1/2"	5 on 4 3/4"	5 on 5"	5 on 5 1/2"	6 on 5 1/2"
IDLER	10TF35-545I	10TF35-5475I	10TF35-550I	10TF35-555I	10TF35-655I
IDLER W/E-Z LUBE®	10TF35-545I-EZ	10TF35-5475I-EZ	10TF35-550I-EZ	10TF35-555I-EZ	10TF35-655I-EZ
IDLER W/E-Z LUBE® GALV	10TF35-545I-EZG	N/A	N/A	N/A	N/A
ELECTRIC	10TF35-545E	10TF35-5475E	10TF35-550E	10TF35-555E	10TF35-655E
ELECTRIC W/E-Z LUBE®	10TF35-545E-EZ	10TF35-5475E-EZ	10TF35-550E-EZ	10TF35-555E-EZ	10TF35-655E-EZ
UNI-SERVO HYDRAULIC	10TF35-545H	10TF35-5475H	10TF35-550H	10TF35-555H	10TF35-655H
UNI-SERVO HYDRAULIC W/E-Z LUBE®	10TF35-545H-EZ	10TF35-5475H-EZ	10TF35-550H-EZ	10TF35-555H-EZ	10TF35-655H-EZ
HYDRAULIC FREEBACK	10TF35-545HFB	10TF35-5475HFB	10TF35-550HFB	10TF35-555HFB	10TF35-655HFB
HYDRAULIC FREEBACK W/E-Z LUBE®	10TF35-545HFB-EZ	10TF35-5475HFB-EZ	10TF35-550HFB-EZ	10TF35-555HFB-EZ	10TF35-655HFB-EZ
HYDRAULIC FREEBACK W/E-Z LUBE®, GALV	10TF35-545HFBZG	N/A	N/A	N/A	N/A
HYDRAULIC DISC	10TF35-545DS	N/A	N/A	N/A	N/A
HYDRAULIC DISC W/E-Z LUBE®	10TF35-545DS-EZ	N/A	N/A	N/A	N/A

#10 TORFLEX® MOUNTING KIT & AXLE OPTIONS

Part No.	Ref. No.	Description
ADD-10TF-VCMBR	056223	ADD-ON #10 TORFLEX® W/V-BEND OPTION
ADD-10TF-NEVRADJ	056224	ADD-ON (PER AXLE) #10 TORFLEX® W/NEV-R-ADJUST® ELECTRIC BRAKE
XTRA-HF-10TF	056225	EXTRA CHARGE (PER AXLE) FOR #10 TORFLEX® OVER 96" HUB FACE
AP166	056310	WELD ON MOUNTING BRAKE KIT FOR #10 TORFLEX®
AP181	056315	ALUM WELD ON MOUNTING BRAKE KIT FOR #10 TORFLEX®



#10 TORFLEX® SPECIFICATIONS



Mounting Details

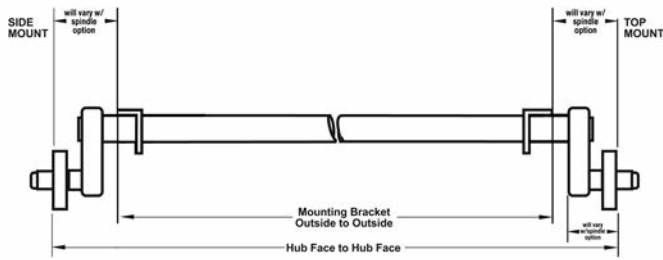

Difference between hubface and outside mounting brackets

Minimum

12.60" (6.3" per side)
Disc=13.12" (6.56" per side)

Maximum

23.60" (11.8" per side)

Note: Minimums are based on manufacturing tolerances only. Some tire and wheel combinations may create interference.



Full Load Dimensions

Dimensions are for low profile, top mount only. High-Profile Bracket Option adds .82" higher. Side mount is .18" higher. Allow 3" bump clearance from full load.

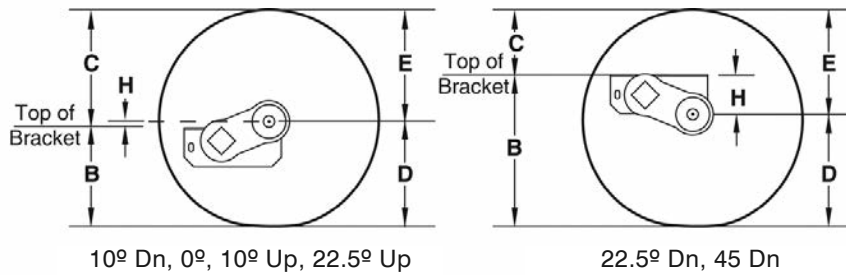

H = Center Line of spindle to top of bracket, B = Top of bracket to ground, C = Top of bracket to top of tire, D = Center Line of spindle to ground, E = Center Line of spindle to top of tire.

START ANGLE

Tire	45° Down			22.5° Down			10° Down			0°			10° Up			22.5° Up			D	E
	H	B	C	H	B	C	H	B	C	H	B	C	H	B	C	H	B	C		
ST175/80R13	3.8	15.0	8.2	1.5	12.7	10.8	0.2	11.4	12.8	-0.8	10.4	12.8	-1.7	9.5	13.7	-2.8	8.4	14.8	11.2	12.0
ST205/75R14	3.8	15.9	9.3	1.5	13.6	11.6	0.2	12.3	13.9	-0.8	11.3	13.9	-1.7	10.4	14.8	-2.8	9.3	15.9	12.1	13.1
ST225/75R15	3.8	16.8	10.6	1.5	14.5	12.9	0.2	13.2	15.2	-0.8	12.2	15.2	-1.7	11.3	16.1	-2.8	10.2	17.2	13.0	14.4

ARTICULATION DIMENSIONS

ALLOW 3" BUMP CLEARANCE FROM FULL LOAD. Positive numbers indicate spindle is below the top of the bracket, negative numbers are above.

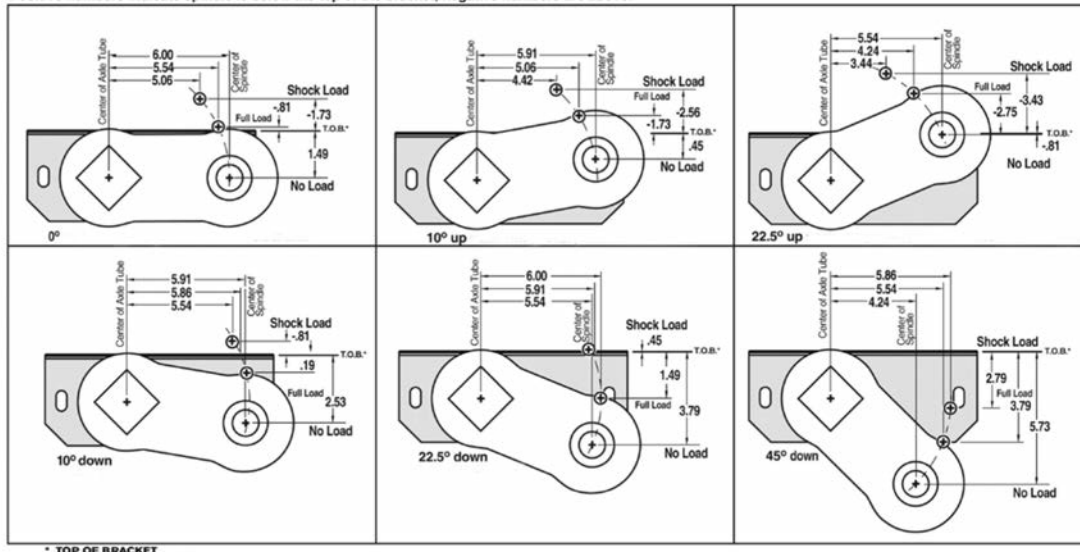

3,500 lb. - 6,000 lb.
#11 TORFLEX®
 RUBBER TORSION SUSPENSION AXLES



SPECIFICATIONS

Suspension: Features an independent suspension cushioned with rubber, providing a smooth, quiet ride with no transfer of road shock from one wheel to the other. (No springs required)

Bolt Pattern Options:

- 6 on 5 1/2" • 8 on 6 1/2"
- UTG 5-Spoke, for 14.5" wheels

Tubing: 3.03" OD Square

Brake Options: with or without parking feature

- 12 x 2" Electric (Manual or Nev-R-Adjust®)
- 12 x 2" Hydraulic (Uni-Servo, Freebacking and Duo-Servo)
- 12 x 2" Hydraulic Freebacking Corrosion Resistant (Galv/Marine Axle)
- Hydraulic Disc

Lubrications: • Grease • E-Z Lube®

- Oil Bath • Nev-R-Lube®

Spindles: TTA (#42 Spindle w/2 1/4" seal journal) 25580 Inner, LM67048, 15123, or 14125A Outer Bearings

- Stainless Steel Wear Sleeves on Galv. Axles

Beams/Options:

- Galvanized Option (Marine) w/GAL-DEX™ Corrosion Resistant Hubs
- V-Bend Beam Option (Marine)

Wheel Assemblies: See Section E

Replacement Parts

- Idler Hub:** See Page B-13 - B-14
- Hub/Drums:** See Page B-20 - B-22, B-32 (Nev-R-Lube)
- Hub/Rotor:** See Page B-34
- Brakes:** See Page C-9 (Elec.), C-23-24 (Hyd. Drum), B-34 (Hyd. Disc)
- Axle Beams:** See Page B-1

#11 TORFLEX® AXLE ASSEMBLIES

Axle Type	6 on 5 1/2"	8 on 6 1/2"	UTG 5-Spoke
STD GREASE	11TF60-655I	11TF60-865I	11TF60-UTGI
W/E-Z LUBE®	11TF60-655I-EZ	11TF60-865I-EZ	11TF60-UTGI-EZ
GALV W/E-Z LUBE®	11TF60-655I-EZG	11TF60-865I-EZG	N/A
W/OIL BATH	N/A	11TF60-865I-OIL	11TF60-UTOI-OIL
Electric			
STD GREASE	11TF60-655E	11TF60-865E	11TF60-UTGE
W/E-Z LUBE®	11TF60-655E-EZ	11TF60-865E-EZ	11TF60-UTGE-EZ
W/NEV-R-LUBE®	11TF60-655E-NL	11TF60-865E-NL	N/A
W/OIL BATH	N/A	11TF60-865E-OIL	11TF60-UTOE-OIL
Uni-Servo Hydraulic			
STD GREASE	11TF60-655H	11TF60-865H	11TF60-HTGH
W/E-Z LUBE®	11TF60-655H-EZ	11TF60-865H-EZ	11TF60-UTGH-EZ
W/NEV-R-LUBE®	11TF60-655H-NL	11TF60-865H-NL	N/A
W/OIL BATH	N/A	11TF60-865H-OIL	11TF60-UTOE-OIL
Uni-Servo Hydraulic Freeback			
STD GREASE	11TF60-655HFB	11TF60-865HFB	11TF60-UTGHFB
W/E-Z LUBE®	11TF60-655HFBEZ	11TF60-865HFBEZ	11TF60-UTGHFBEZ
GALV W/E-Z LUBE®	11TF60-655HFBEZG	11TF60-865HFBEZG	N/A
W/NEV-R-LUBE®	11TF60-655HFB-NL	11TF60-865HFB-NL	N/A
W/OIL BATH	N/A	11TF60-865HFBOIL	11TF60-UTOHFBOIL
Duo-Servo Hydraulic			
STD GREASE	11TF60-655HY	11TF60-865HY	11TF60-YUTGHY
W/E-Z LUBE®	11TF60-655HY-EZ	11TF60-865HY-EZ	11TF60-UTGHY-EZ
W/NEV-R-LUBE®	11TF60-655HY-NL	11TF60-865HY-NL	N/A
W/OIL BATH	N/A	11TF60-865HYOIL	11TF60-UTOHYOIL
Hydraulic Disc			
STD GREASE	11TF60-655DS	N/A	N/A
W/E-Z LUBE®	11TF60-655DS-EZ	N/A	N/A
W/NEV-R-LUBE®	11TF60-655DS-NL	N/A	N/A
W/OIL BATH	N/A	N/A	N/A

#11 TORFLEX® MOUNTING KIT & AXLE OPTIONS

Part No.	Ref. No.	Description
ADD-11TF-VCMBR	060149	ADD-ON #11 TORFLEX® W/V-BEND OPTION
XTRA-HF-11TF	060150	EXTRA CHARGE (PER AXLE) FOR #11 TORFLEX® OVER 96" HUB FACE
ADD-11TF-NEVRADJ	060151	ADD-ON (PER AXLE) #11 TORFLEX® W/NEV-R-ADJUST® ELECTRIC BRAKE
AP167	060190	WELD ON MOUNTING BRAKE KIT FOR #11 TORFLEX®
AP182	060195	ALUM WELD ON MOUNTING BRAKE KIT FOR #11 TORFLEX®



#11 TORFLEX® SPECIFICATIONS



Mounting Details

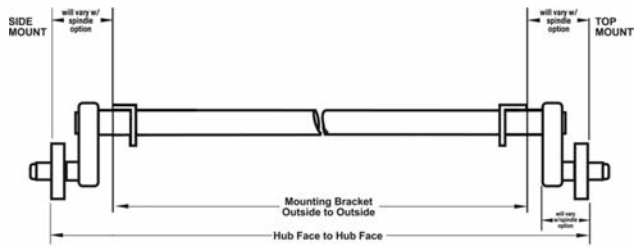

Difference between hubface and outside mounting brackets

Minimum

Short 14.00" (7" per side)/Disc=15.00" (7.5" per side)
 Standard 14.94" (7.47" per side)/Disc=15.00" (7.5" per side)

Maximum

5200 lb. - 23.60" (11.8 per side)
 6000 lb. - 20.45" (10.22 per side)

Note: Minimums are based on manufacturing tolerances only. Some tire and wheel combinations may create interference.

11 Full Load Dimensions

Dimensions are for low profile, top mount only. High-profile brackets are .75". Side mount is .25" higher. Allow 3" bump clearance from full load.

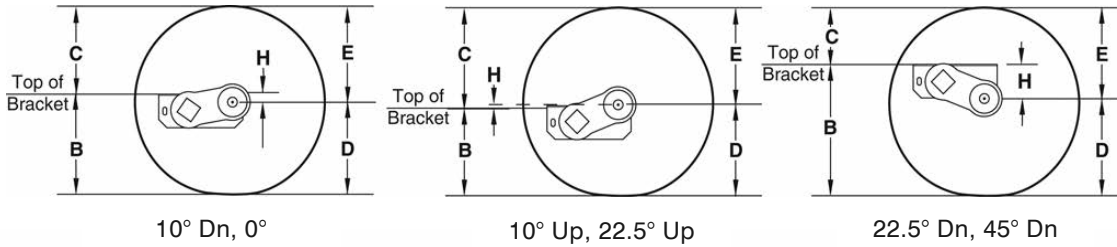

H = Center Line of spindle to top of bracket, B = Top of bracket to ground, C = Top of bracket to top of tire, D = Center Line of spindle to ground, E = Center Line of spindle to top of tire.

START ANGLE

Tire	45° Down			22.5° Down			10° Down			0°			10° Up			22.5° Up			D	E
	H	B	C	H	B	C	H	B	C	H	B	C	H	B	C	H	B	C		
ST225/75R15	4.1	17.1	10.3	1.8	14.8	12.6	0.5	13.5	13.9	-0.5	12.5	14.9	-1.5	11.5	15.9	-2.5	10.5	16.9	13.0	14.4
LT235/85R16	4.1	18.4	11.3	1.8	16.1	13.6	0.5	14.8	14.9	-0.5	13.8	15.9	-1.5	12.8	16.9	-2.5	11.8	17.9	14.3	15.4
LT225/75R16	4.1	17.6	10.8	1.8	15.3	13.1	0.5	14.0	14.4	-0.5	13.0	15.4	-1.5	12.0	16.4	-2.5	11.0	17.4	13.5	14.9

ARTICULATION DIMENSIONS

ALLOW 3" BUMP CLEARANCE FROM FULL LOAD. Positive numbers indicate spindle is below the top of the bracket, negative numbers are above.

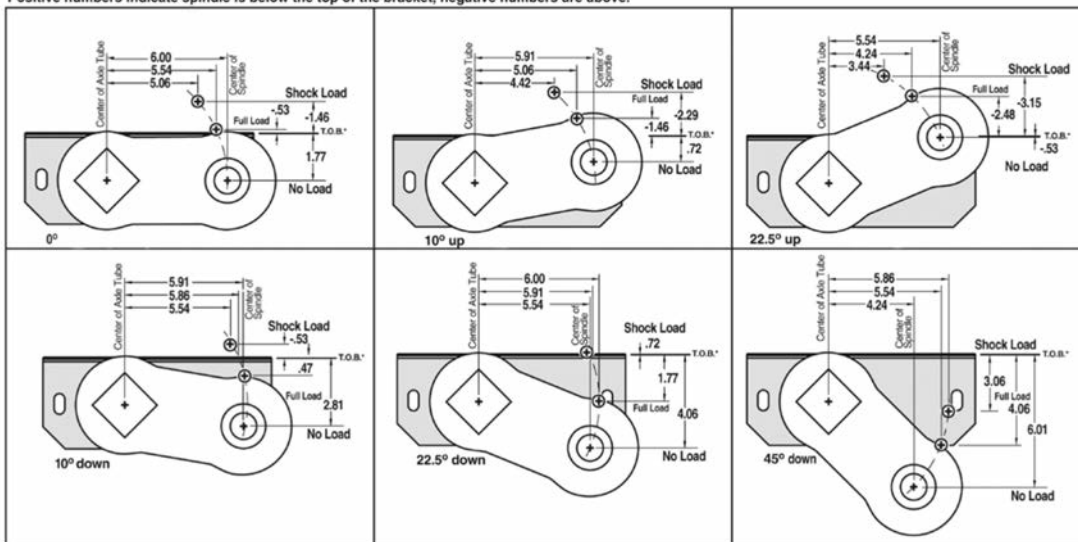



SPECIFICATIONS

Suspension: Features an independent suspension cushioned with rubber, providing a smooth, quiet ride with no transfer of road shock from one wheel to the other. (No springs required)

Bolt Pattern Options:

- #12: • 8 on 6 1/2" • UTG 5-Spoke
 #12V: • 8 on 6 1/2" (9/16" Studs Standard or optional 5/8")

Tubing: 3.50" OD Square

Brake Options:

- #12: • Some available with parking feature
 • 12 x 2" Electric (Manual or Nev-R-Adjust®)
 • 12 x 2" Hydraulic (Uni-Servo, Freebacking and Duo-Servo)
 • 12 x 2" Hydraulic Freebacking Corrosion Resistant (Galv/Marine Axle)
 • 7K Disc Brake-Integral Hub/Rotor
 #12V: • 12 1/4" x 2 1/2" Electric Only

Lubrications: • Grease • E-Z Lube®
 • Oil Bath • Nev-R-Lube®

Spindles:

- #12: • UTA (#42 Spindle w/2 1/4" seal journal) 25580 Inner, LM67048, 15123, or 14125A Outer Bearings
 • Stainless Steel Wear Sleeves on Galv. Axles
 #12V: • 22580 Inner, 02475 Outer Bearings

Beams/Options:

- Galvanized Option (Marine) w/GAL-DEX™ Corrosion Resistant Hubs
 • V-Bend Beam Option (Marine)

Wheel Assemblies: See Section E

Replacement Parts

- Idler Hub:** #12 See Page B-14, #12V - N/A
Hub/Drums: #12 See Page B-22, B-32 (Nev-R-Lube)
 #12V See Page B-23
Brakes: #12 See Page C-9 (Elec.), C-23-24 (Hyd.),
 #12V See Page C-10 (Electric)
Axle Beams: See Page B-1

#12 TORFLEX® AXLE ASSEMBLIES - 7,000lb

Axle Type	8 on 6 1/2"	UTG 5-Spoke
STD GREASE	12TF70-865I	12TF70-UTGI
W/E-Z LUBE®	12TF70-865I-EZ	12TF70-UTGI-EZ
GALV W/E-Z LUBE®	12TF70-865I-EZG	N/A
W/OIL BATH	12TF70-865I-OIL	12TF70-UTGI-OIL

Electric

STD GREASE	12TF70-865E	12TF70-UTGE
W/E-Z LUBE®	12TF70-865E-EZ	12TF70-UTGE-EZ
W/NEV-R-LUBE®	12TF70-865E-NL	N/A
W/OIL BATH	12TF70-865E-OIL	12TF70-UTOE-OIL

Disc

STD GREASE	12TF70-865DS	N/A
W/E-Z LUBE®	12TF70-865DS-EZ	N/A
W/NEV-R-LUBE®	N/A	N/A
W/OIL BATH	12TF70-865DS-OIL	N/A

Uni-Servo Hydraulic

STD GREASE	12TF70-865H	12TF70-UTGH
W/E-Z LUBE®	12TF70-865H-EZ	12TF70-UTGH-EZ
W/NEV-R-LUBE®	12TF70-865H-NL	N/A
W/OIL BATH	12TF70-865H-OIL	12TF70-UTOH-OIL

Uni-Servo Hydraulic Freeback

STD GREASE	12TF70-865HFHFB	12TF70-UTGHFHB
W/E-Z LUBE®	12TF70-865HFHBEZ	12TF70-UTGHFBEZ
GALV W/E-Z LUBE®	12TF70-865HFHBEZG	N/A
W/NEV-R-LUBE®	12TF70-865HFBNL	N/A
W/OIL BATH	12TF70-865HFBOIL	12TF70-UTOHFBOIL

Duo-Servo Hydraulic

STD GREASE	12TF70-865HY	12TF70-UTGHY
W/E-Z LUBE®	12TF70-865HY-EZ	12TF70-UTGHY-EZ
W/NEV-R-LUBE®	12TF70-865HY-NL	N/A
W/OIL BATH	12TF70-865HYOIL	12TF70-UTOHYOIL

#12 TORFLEX® AXLE ASSEMBLIES - 7,200lb

Axle Type	8 on 6 1/2"	UTG 5-Spoke
STD GREASE	12TF70-865E	N/A
W/E-Z LUBE®	12TF70-865E-EZ	N/A
W/OIL BATH	12TF70-865E-OIL	N/A

#12 & 12V TORFLEX® MOUNTING KIT & AXLE OPTIONS

Part No.	Ref. No.	Description
ADD-12TF-VCMBR	063274	ADD-ON #12 TORFLEX® W/V-BEND OPTION
XTRA-HF-12TF	063275	EXTRA CHARGE (PER AXLE) FOR #12 TORFLEX® OVER 96" HUB FACE
ADD-12TF-NEVRADJ	063276	ADD-ON (PER AXLE) #12 TORFLEX® W/NEV-R-ADJUST® ELECTRIC BRAKE
AP168	063290	WELD ON MOUNTING BRAKE KIT FOR #12 TORFLEX®
AP183	063295	ALUM WELD ON MOUNTING BRAKE KIT FOR #12 TORFLEX®



#12 & #12V TORFLEX® SPECIFICATIONS



Mounting Details

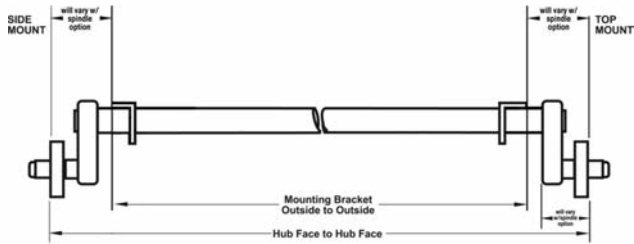

Difference between hubface and outside mounting brackets

Minimum

#12 Standard 14.94" (7.47 per side)

#12 Short 14.00" (7" per side)

#12V Standard 14.00" (7" per side)

Maximum

#12 - 30.40" (15.2" per side)

#12V - 29.55" (14.775" per side)

Note: Minimums are based on manufacturing tolerances only. Some tire and wheel combinations may create interference.



Full Load Dimensions

Dimensions are for low profile, top mount only. High-profile brackets are .75". Side mount is .31" higher. Allow 3" bump clearance from full load.

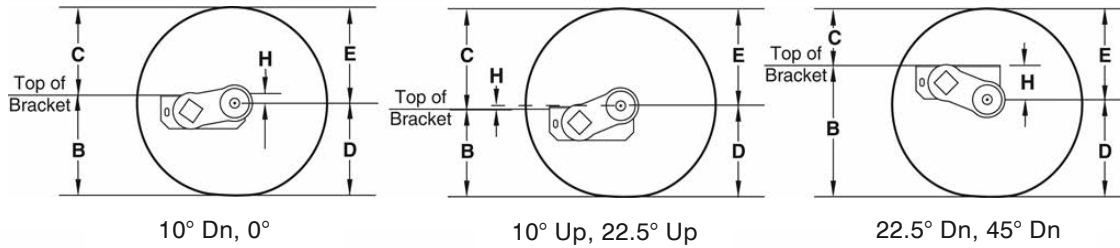

H = Center Line of spindle to top of bracket, **B** = Top of bracket to ground, **C** = Top of bracket to top of tire, **D** = Center Line of spindle to ground, **E** = Center Line of spindle to top of tire.

START ANGLE

Tire	45° Down			22.5° Down			10° Down			0°			10° Up			22.5° Up			D	E
	H	B	C	H	B	C	H	B	C	H	B	C	H	B	C	H	B	C		
LT235/85R16	4.3	18.6	11.1	2.0	16.3	13.4	0.7	15.0	14.7	-0.3	14.0	15.7	-1.2	13.1	16.6	-2.2	12.1	17.6	14.3	15.4
7.5-16LT	4.3	19.2	12.4	2.0	16.9	14.7	0.7	15.6	16.0	-0.3	14.6	17.0	-1.2	13.7	17.9	-2.2	12.7	18.9	14.9	16.7

ARTICULATION DIMENSIONS

ALLOW 3" BUMP CLEARANCE FROM FULL LOAD.

Positive numbers indicate spindle is below the top of the bracket, negative numbers are above.

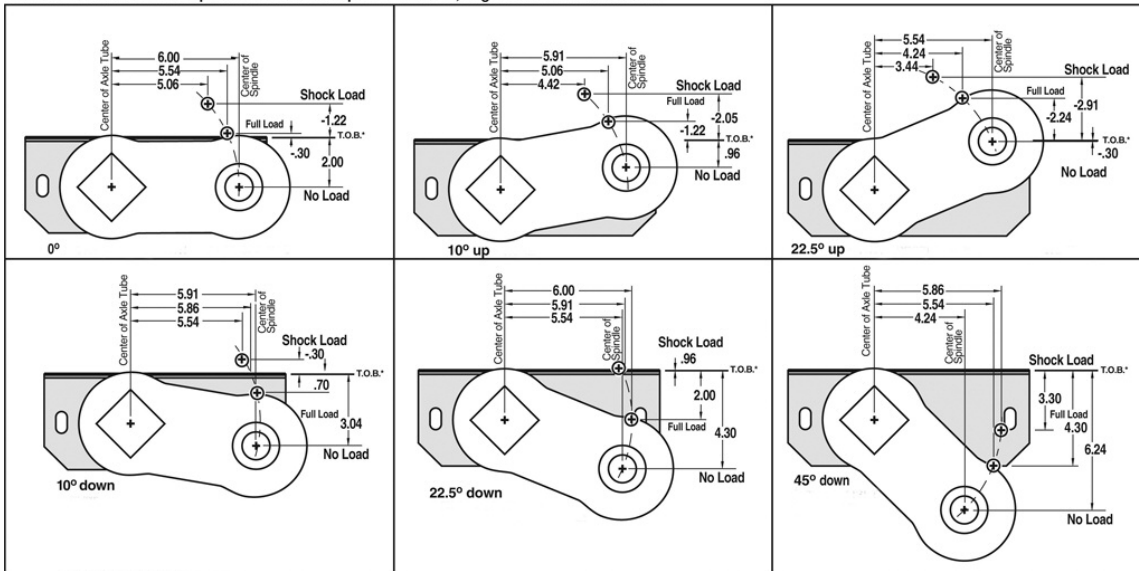

* TOP OF BRACKET



8,000 lb.
#13 TORFLEX®
 RUBBER TORSION SUSPENSION AXLES



SPECIFICATIONS

Suspension:

Features an independent suspension cushioned with rubber, providing a smooth, quiet ride with no transfer of road shock from one wheel to the other. (No springs required)

Brake Options: (Forward Self-Adjusting)

- 12 1/4" x 3 3/8" Electric
- 12 1/4" x 3 3/8" Hydraulic (Duo-Servo Standard, Optional Uni-Servo) Some available with parking feature
- Hydraulic Disc
- ABS Equipped options for hydraulic brakes

Bolt Pattern Options:

- 8 on 6 1/2" (9/16" Studs Standard or Optional 5/8")

Tubings: • 3.88" OD Square

Spindles: 222580 Inner, 02475 Outer Bearings

Lubrication: • Oil Bath • E-Z Lube® • Nev-R-Lube®

Wheel Assemblies: See Section E

#13 TORFLEX® AXLE ASSEMBLIES

Axle Type	8 on 6 1/2"
IDLER OIL BATH	13TF80-865I
IDLER W/E-Z LUBE®	13TF80-865I-EZ
ELECTRIC OIL BATH	13TF80-865E
ELECTRIC W/E-Z LUBE®	13TF80-865E-EZ
ELECTRIC W/NEV-R-LUBE®	13TF80-865E-NL
DUO-SERVO HYDRAULIC, OIL BATH	13TF80-865HY
DUO-SERVO HYDRAULIC W/E-Z LUBE®	13TF80-865HY-EZ
DUO-SERVO HYDRAULIC W/NEV-R-LUBE®	13TF80-865HY-NL
HYDRAULIC OIL BATH	13TF80-865DS
HYDRAULIC DISC W/E-Z LUBE®	13TF80-865DS-EZ
HYDRAULIC DISC W/NEV-R-LUBE®	13TF80-865DS-NL

Replacement Parts

Idler Hub: See Page B-15

Hub/Drums: See Page B-25, B-32 (Nev-R-Lube)

Hub/Rotor: See Page B-36

Brakes: See Page C-11 (Electric),
C-25 (Hyd. Drum), B-36 (Hyd. Disc)

Axle Beams: See Page B-1

#13 TORFLEX® MOUNTING KIT & AXLE OPTIONS

Part No.	Ref. No.	Description
XTRA-HF-13TF	064625	EXTRA CHARGE (PER AXLE) FOR AXLES OVER 96" HUB FACE
13TF-HYD-PARK	064800	HYDRAULIC BRAKES W/ PARK, ADD TO #13 TORFLEX® HYDRAULIC BRAKE AXLE PRICE
13TF-ADD-HYABS	064860	EXTRA CHARGE (PER AXLE) FOR HYDRAULIC BRAKE AXES W/ ABS SENSORS & TONE RINGS INSTALLED
AP169	064900	WELD ON MOUNTING BRACKET KIT FOR #13 TORFLEX® AXLES



#13 TORFLEX® SPECIFICATIONS



Mounting Details

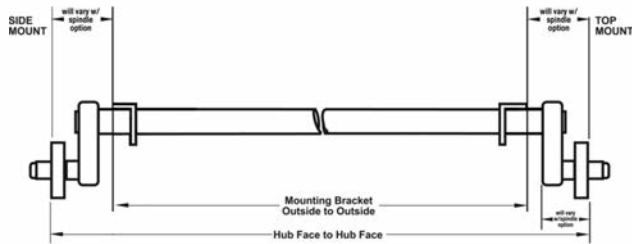

Difference between hubface and outside mounting brackets

Minimum

Short 17.00" (8.5" per side)
Standard 18.00" (9.00" per side)

Maximum

43.00" (21.5" per side)

Note: Minimums are based on manufacturing tolerances only. Some tire and wheel combinations may create interference.

13 Full Load Dimensions

Dimensions are for low profile, top mount only. High-profile brackets are .75". Side mount is .31" higher. Allow 3" bump clearance from full load.

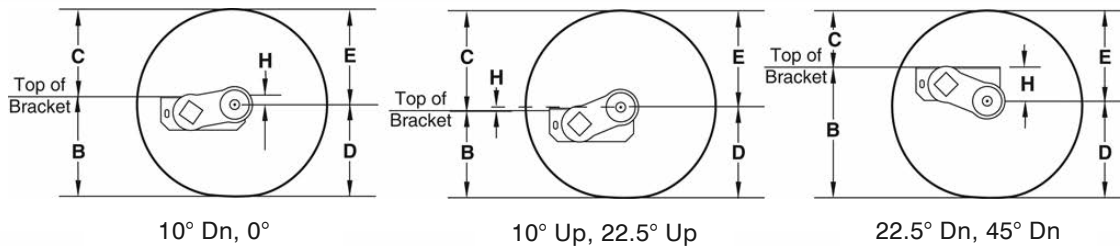

H = Center Line of spindle to top of bracket, B = Top of bracket to ground, C = Top of bracket to top of tire, D = Center Line of spindle to ground, E = Center Line of spindle to top of tire.

START ANGLE

Tire	45° Down			22.5° Down			10° Down			0°			10° Up			22.5° Up			D	E
	H	B	C	H	B	C	H	B	C	H	B	C	H	B	C	H	B	C		
10R17.5 HC	4.6	20.2	13.4	2.3	17.9	15.7	1.0	16.6	17.0	-0.1	15.5	18.1	-1.0	14.6	19.0	-2.0	13.6	20.0	15.6	18.0
215/75R 17.5	4.6	18.6	10.7	2.3	16.3	13.0	1.0	15.0	14.3	-0.1	13.9	15.4	-1.0	13.0	16.3	-2.0	12.0	17.3	14.0	15.3
9R 17.5 HC	4.6	20.0	12.5	2.3	17.7	14.8	1.0	16.4	16.1	-0.1	15.3	17.2	-1.0	14.4	18.1	-2.0	13.4	19.1	15.4	17.1

ARTICULATION DIMENSIONS

ALLOW 3" BUMP CLEARANCE FROM FULL LOAD. Positive numbers indicate spindle is below the top of the bracket, negative numbers are above.

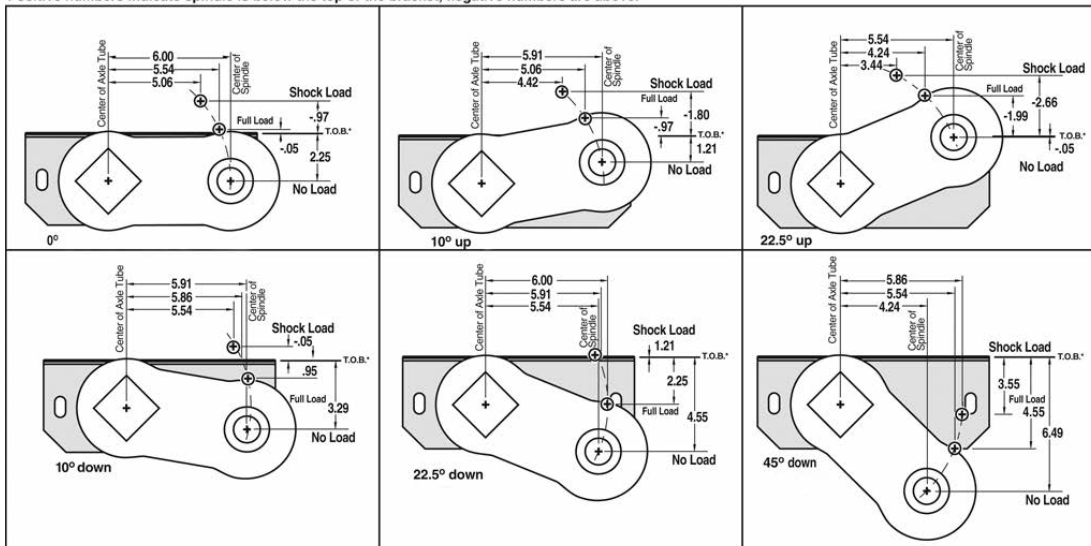

* TOP OF BRACKET



13 TORFLEX
 RUBBER TORSION SUSPENSION AXLES
 General Duty 9,000 lb. - 10,000 lb.
 Heavy Duty 9,000 lb. - 10,000 lb.



SPECIFICATIONS

Suspension:

Features an independent suspension cushioned with rubber, providing a smooth, quiet ride with no transfer of road shock from one wheel to the other. (No springs required)

Brake Options: (Foward Self-Adjusting)

#13G (10K GD):

- 12 1/4" x 3 3/8" Electric
- 12 1/4" x 3 3/8" Hydraulic, Duo-Servo Standard; (Optional Uni-Servo) w/ or without parking feature
- Hydraulic Disc
- ABS Equipped options for hydraulic drum brakes

#13D (10K HD):

- 12 1/4" x 4" Electric
- 12 1/4" x 4" Hydraulic, Duo-Servo Standard; (Optional Uni-Servo) w/ or without parking feature
- Hydraulic Disc
- ABS Equipped options for hydraulic drum brakes

Bolt Pattern Options: • 8 on 6 1/2"

Tubings: • 3.88" OD Square

Spindles:

#13G: • 387A Inner, 25580 Outer Bearings

#13D: • 395S Inner, 387A Outer Bearings

Lubrication: • Oil Bath

Wheel Assemblies: See Section E

#13G GD TORFLEX® AXLE ASSEMBLIES

Axle Type	8 on 6 1/2"	ABS Equipped, 8 on 6 1/2"
ELECTRIC DUO-SERVO	10GDTF-865E	N/A
HYDRAULIC	10GDTF-865HY	10GDTF-865HABS
HYDAULIC DISC	10GDTF-865DS	N/A

#13D HD TORFLEX® AXLE ASSEMBLIES

Axle Type	8 on 6 1/2"	ABS Equipped, 8 on 6 1/2"
ELECTRIC DUO-SERVO	10HDTF-865E	N/A
HYDRAULIC	10HDTF-865HY	10HDTF-865HABS
HYDAULIC DISC	10HDTF-865DS	N/A

Replacement Parts

Idler Hub: See Page B-26 - B-27

Brakes: 10K GD See Page C-14 (Electric), and C-26 (Hydraulic Drum)
 10K HD See page C-14 (Electric), and C-27 (Hydraulic Drum)

#13 TORFLEX® MOUNTING KIT & AXLE OPTIONS

Part No.	Ref. No.	Description
AP169	064900	WELD ON MOUNTING BRACKET KIT FOR #10 TORFLEX® AXLES
10KTF-HYD-PARK	064970	HYDRAULIC BRAKES W/ PARK, ADD TO #10K TORFLEX® HYDRAULIC BRAKE AXLE PRICE



#13G - #13D TORFLEX® SPECIFICATIONS



Mounting Details

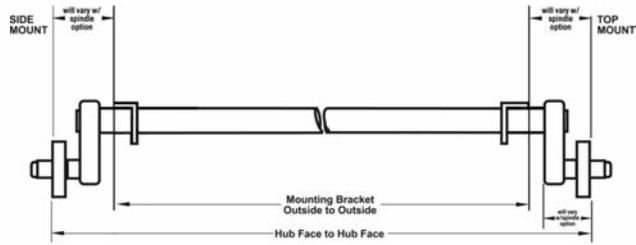

Difference between hubface and outside mounting brackets

Minimum

- 10K GD - 20.22" (10.11" per side)*
- 10K HD - 24.50" (12.25" per side)

Maximum

- 10K GD & HD - 34.40" (17.2 per side)

Note: Minimums are based on manufacturing tolerances only. Some tire and wheel combinations may create interference.

*10K GD (#13G) is for SINGLE WHEEL only!



Full Load Dimensions

Dimensions are for low profile, top mount only. Side mount is .31" higher. Allow 3" bump clearance from full load.

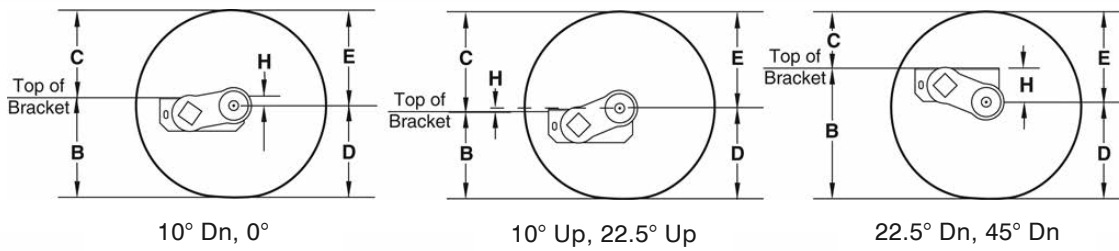

H = Center Line of spindle to top of bracket, B = Top of bracket to ground, C = Top of bracket to top of tire, D = Center Line of spindle to ground, E = Center Line of spindle to top of tire.

START ANGLE

Tire	45° Down			22.5° Down			10° Down			0°			10° Up			22.5° Up			D	E
	H	B	C	H	B	C	H	B	C	H	B	C	H	B	C	H	B	C		
10R17.5 HC	4.6	20.2	13.4	2.3	17.9	15.7	1.0	16.6	17.0	-0.1	15.5	18.1	-1.0	14.6	19.0	-2.0	13.6	20.0	15.6	18.0
215/75R 17.5	4.6	18.6	10.7	2.3	16.3	13.0	1.0	15.0	14.3	-0.1	13.9	15.4	-1.0	13.0	16.3	-2.0	12.0	17.3	14.0	15.3
9R 17.5 HC	4.6	20.0	12.5	2.3	17.7	14.8	1.0	16.4	16.1	-0.1	15.3	17.2	-1.0	14.4	18.1	-2.0	13.4	19.1	15.4	17.1

ARTICULATION DIMENSIONS

ALLOW 3" BUMP CLEARANCE FROM FULL LOAD. Positive numbers indicate spindle is below the top of the bracket, negative numbers are above.

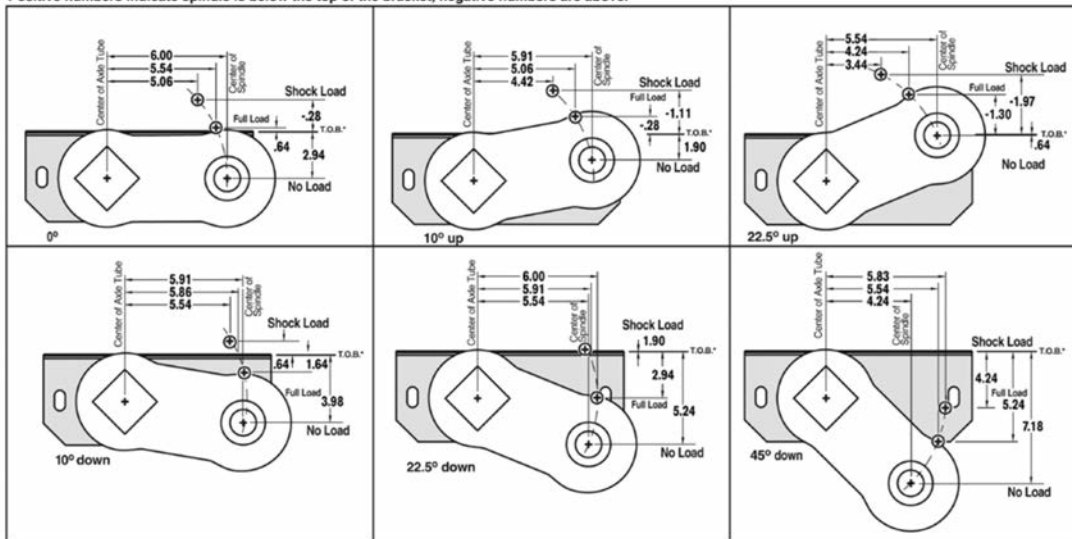

* TOP OF BRACKET



HOW TO READ TORFLEX® ARTICULATION DIMENSIONS

Note: Dimensions shown here are for example only. Refer to specific Torflex® Axle Page for correct dimensions.

A) How high do I set the fenders?

Look at the 0° drawing: The 1.49 is distance from center of spindle to top of bracket.
The -.81 is how far arm moves above bracket for 'Full Load'.

- 1.49 To top bracket
- +.81 From top bracket to 'Full Load'
- 2.3 Travel from 'No Load' to 'Full Load'

Fenders should be located 5.3" above tires when 'No Load' (2.3" + 3.00 DEX RECOMMENDED).



B) What is 'Shock Load'?

'Shock Load' -1.73 is how far arm travels above the top of bracket. The distance the arm moves from 'Full Load' to 'Shock Load' is the difference of .92.

- 1.73 Distance arm moves from 'Full Load' to 'Shock Load'
- .81 Full Load Dimension
- 0.92 Travel from 'Full Load' to 'Shock Load'

C) What do the + marks on the curved broken line represent?

This line tells us how far forward the tire moves at each of the load points.

Using the 0° drawing again: Notice the 6.0 distance from center of spindle to center of inner bar. When the arm travels up to 'Full Load', the tire is moved forward .46". At 'Shock Load', the tire has moved forward .94".

D) When trailing arm starts at 22.5° or 45° down, the calculations are subtractions rather than addition.

Look at 22.5° down drawing.

- 3.79 'No Load' is 3.79 from top of bracket
- 1.49 'Full Load' is 1.49 from top of bracket
- 2.30 Travel from "No Load" to "Full Load"

'Shock Load' is .45 below top of bracket, so the travel from 'Full Load' 3.79 to 'Shock Load' .45 is 3.34".

ARTICULATION DIMENSIONS

ALLOW 3" BUMP CLEARANCE FROM FULL LOAD.

Positive numbers indicate spindle is below the top of the bracket, negative numbers are above.

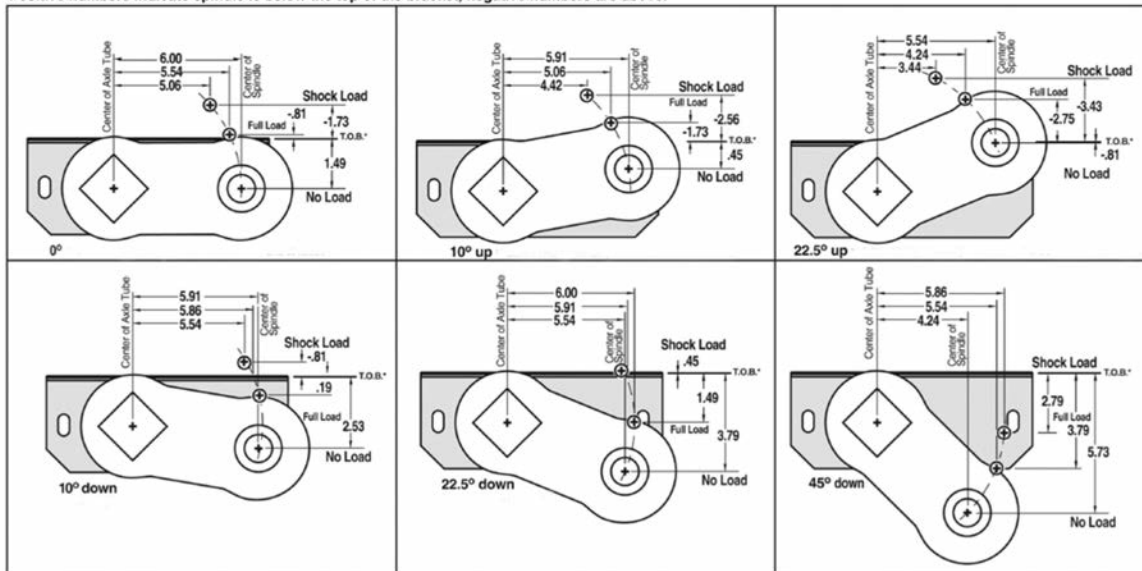

* TOP OF BRACKET

