

Agilent 83491/2/3A Clock Recovery Modules User's Guide

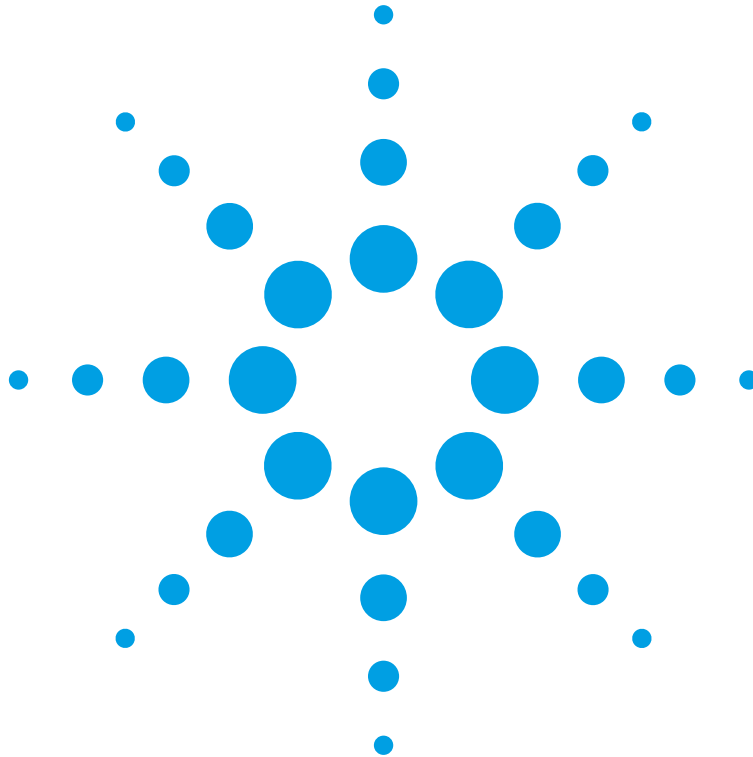

Agilent Technologies

© Copyright 2000
Agilent Technologies
All Rights Reserved. Reproduction, adaptation, or translation without prior written permission is prohibited, except as allowed under copyright laws.

Agilent Part No. 83491-90013
Printed in USA
February 2000

Agilent Technologies
Lightwave Division
1400 Fountaingrove Parkway
Santa Rosa, CA 95403-1799,
USA
(707) 577-1400

Notice.

The information contained in this document is subject to change without notice. Companies, names, and data used in examples herein are fictitious unless otherwise noted. Agilent Technologies makes no warranty of any kind with regard to this material, including but not limited to, the implied warranties of merchantability and fitness for a particular purpose. Agilent Technologies shall not be liable for errors contained herein or for incidental or consequential damages in connection with the furnishing, performance, or use of this material.

Restricted Rights Legend.

Use, duplication, or disclosure by the U.S. Government is subject to restrictions as set forth in subparagraph (c) (1) (ii) of the Rights in Technical Data and Computer Software clause at DFARS 252.227-7013 for DOD agencies, and subparagraphs (c) (1) and (c) (2) of the Commercial Computer Software Restricted Rights clause at FAR 52.227-19 for other agencies.

Warranty.

This Agilent Technologies instrument product is warranted against defects in

material and workmanship for a period of one year from date of shipment. During the warranty period, Agilent Technologies will, at its option, either repair or replace products which prove to be defective. For warranty service or repair, this product must be returned to a service facility designated by Agilent Technologies. Buyer shall prepay shipping charges to Agilent Technologies and Agilent Technologies shall pay shipping charges to return the product to Buyer. However, Buyer shall pay all shipping charges, duties, and taxes for products returned to Agilent Technologies from another country.

Agilent Technologies warrants that its software and firmware designated by Agilent Technologies for use with an instrument will execute its programming instructions when properly installed on that instrument. Agilent Technologies does not warrant that the operation of the instrument, or software, or firmware will be uninterrupted or error-free.

Limitation of Warranty.

The foregoing warranty shall not apply to defects resulting from improper or inadequate maintenance by Buyer, Buyer-supplied software or interfacing, unauthorized modification or misuse, operation outside of the environmental specifications for the product, or improper site preparation or maintenance.

No other warranty is expressed or implied. Agilent Technologies specifically disclaims the implied warranties of merchantability and fitness for a particular purpose.

Exclusive Remedies.

The remedies provided herein are buyer's sole and exclusive remedies. Agilent Technolo-

gies shall not be liable for any direct, indirect, special, incidental, or consequential damages, whether based on contract, tort, or any other legal theory.

Safety Symbols.

CAUTION

The *caution* sign denotes a hazard. It calls attention to a procedure which, if not correctly performed or adhered to, could result in damage to or destruction of the product. Do not proceed beyond a caution sign until the indicated conditions are fully understood and met.

WARNING

The *warning* sign denotes a hazard. It calls attention to a procedure which, if not correctly performed or adhered to, could result in injury or loss of life. Do not proceed beyond a warning sign until the indicated conditions are fully understood and met.



The instruction manual symbol. The product is marked with this warning symbol when it is necessary for the user to refer to the instructions in the manual.



The laser radiation symbol. This warning symbol is marked on products which have a laser output.



The AC symbol is used to indicate the required nature of the line module input power.



The ON symbols are used to mark the positions of the instrument power line switch.



The OFF symbols are used to mark the positions of the instrument power line switch.



The CE mark is a registered trademark of the European Community.



The CSA mark is a registered trademark of the Canadian Standards Association.



The C-Tick mark is a registered trademark of the Australian Spectrum Management Agency.

ISM1-A

This text denotes the instrument is an Industrial Scientific and Medical Group 1 Class A product.

Typographical Conventions.

The following conventions are used in this book:

Key type for keys or text located on the keyboard or instrument.

Softkey type for key names that are displayed on the instrument's screen.

Display type for words or characters displayed on the computer's screen or instrument's display.

User type for words or characters that you type or enter.

Emphasis type for words or characters that emphasize some point or that are used as place holders for text that you type.

General Safety Considerations

This product has been designed and tested in accordance with IEC Publication 61010-1, Safety Requirements for Electrical Equipment for Measurement, Control and Laboratory Use, and has been supplied in a safe condition. The instruction documentation contains information and warnings that must be followed by the user to ensure safe operation and to maintain the product in a safe condition.

WARNING

Light energy can radiate from the front panel OUTPUT connectors on Agilent 83492A and 83493A modules. The light emitted from these connectors is the slightly attenuated light that is input to the front-panel INPUT connector.

WARNING

If this instrument is not used as specified, the protection provided by the equipment could be impaired. This instrument must be used in a normal condition (in which all means for protection are intact) only.

WARNING

To prevent electrical shock, disconnect the Agilent 83491/2/3A from mains before cleaning. Use a dry cloth or one slightly dampened with water to clean the external case parts. Do not attempt to clean internally.

WARNING

This is a Safety Class 1 product (provided with a protective earthing ground incorporated in the power cord). The mains plug shall only be inserted in a socket outlet provided with a protective earth contact. Any interruption of the protective conductor inside or outside of the product is likely to make the product dangerous. Intentional interruption is prohibited.

WARNING

No operator serviceable parts inside. Refer servicing to qualified personnel. To prevent electrical shock, do not remove covers.

WARNING

For continued protection against fire hazard, replace line fuse only with same type and ratings, (type T 0.315A/250V for 100/120V operation and 0.16A/250V for 220/240V operation). The use of other fuses or materials is prohibited. Verify that the value of the line-voltage fuse is correct.

- For 100/120V operation, use an IEC 127 5×20 mm, 0.315 A, 250 V, Agilent

General Safety Considerations

Technologies part number 2110-0449.

- For 220/240V operation, use an IEC 127 5×20 mm, 0.16 A, 250 V, Agilent Technologies part number 2110-0448.

CAUTION

Before switching on this instrument, make sure that the line voltage selector switch is set to the line voltage of the power supply and the correct fuse is installed. Assure the supply voltage is in the specified range.

CAUTION

This product is designed for use in Installation Category II and Pollution Degree 2 per IEC 1010 and 664 respectively.

CAUTION

VENTILATION REQUIREMENTS: When installing the product in a cabinet, the convection into and out of the product must not be restricted. The ambient temperature (outside the cabinet) must be less than the maximum operating temperature of the product by 4°C for every 100 watts dissipated in the cabinet. If the total power dissipated in the cabinet is greater than 800 watts, then forced convection must be used.

CAUTION

Always use the three-prong ac power cord supplied with this instrument. Failure to ensure adequate earth grounding by not using this cord may cause instrument damage.

CAUTION

Do not connect ac power until you have verified the line voltage is correct. Damage to the equipment could result.

CAUTION

This instrument has autoranging line voltage input. Be sure the supply voltage is within the specified range.

CAUTION

Electrostatic discharge (ESD) on or near input connectors can damage circuits inside the instrument. Repair of damage due to misuse is *not* covered under warranty. Before connecting any cable to the electrical input, momentarily short the center and outer conductors of the cable together. Personnel should be properly grounded, and should touch the frame of the instrument before touching any connector.

Contents

General Safety Considerations iii

1 Installation

Installation 1-2

2 Operation

Agilent 83491/2/3A Modules—At a Glance 2-2

Front-Panel Features 2-4

Block Diagrams 2-7

To Display a Signal 2-8

To Compensate for Module Insertion Loss 2-9

Using Probes with an Agilent 83491A 2-10

3 Specifications and Regulatory Information

Agilent 83491A Specifications 3-3

Agilent 83492A Specifications 3-4

Agilent 83493A Specifications 3-6

Agilent 83491/2/3A Operating Specifications 3-7

Declaration of Conformity 3-8

4 Reference

Front-Panel Optical Adapters 4-2

In Case of Difficulty 4-3

Error Messages 4-5

Electrostatic Discharge Information 4-8

Cleaning Connections for Accurate Measurements 4-10

Returning the Instrument for Service 4-20

Agilent Technologies Service Offices 4-23

1

To install the module 1-3

To connect cables to an Agilent 83492A 1-7

Installation

Installation

Agilent 83491/2/3A modules require that firmware revision A.06.25 or later be installed in the Agilent 83480A. If you wish to install the module in an Agilent 54750A digitizing oscilloscope, you must first install the Agilent 83480K communications firmware upgrade kit.

To check the Agilent 83480A's firmware revision code

- 1 Press the Utility key and then the *System config* softkey.
- 2 The firmware revision number is listed under the Frame section of the display.

CAUTION

Fiber-optic connectors are easily damaged when connected to dirty or damaged cables and accessories. The Agilent 83492A and 83493A front-panel input connectors are no exception. When you use improper cleaning and handling techniques, you risk expensive instrument repairs, damaged cables, and compromised measurements. Before you connect any fiber-optic cable to an Agilent 83492A or 83493A module, refer to “Cleaning Connections for Accurate Measurements” on page 4-10.

CAUTION

The circuits on electrical inputs and outputs can be damaged by electrostatic discharge (ESD). Therefore, avoid applying static discharges to any front or rear-panel electrical connector. Before connecting any coaxial cable to a front-panel connector, momentarily short the center and outer conductors of the cable together. Avoid touching the front-panel connectors without first touching the frame of the instrument. Be sure that the instrument is properly earth-grounded to prevent buildup of static charge. Refer to “Electrostatic Discharge Information” on page 4-8.

To install the module

- 1 Verify that all system components ordered have arrived by comparing the shipping forms to the original purchase order. Inspect all shipping containers. The shipment includes:
 - An Agilent 83491/2/3A Clock Recovery Module
 - Fiber-optic adapter cable (*Agilent 83492/3A module only*)
 - Two RF adapter cables (*Agilent 83491A module only*)
 - Agilent 83491/2/3A User's Guide (this book)*

If your shipment is damaged or incomplete, save the packing materials and notify both the shipping carrier and the nearest Agilent Technologies service office. Agilent Technologies will arrange for repair or replacement of damaged or incomplete shipments without waiting for a settlement from the transportation company. Notify the Agilent Technologies customer engineer of any problems.

- 1 Make sure that the serial number listed on the module's rear-panel label matches the serial number listed on the shipping document.

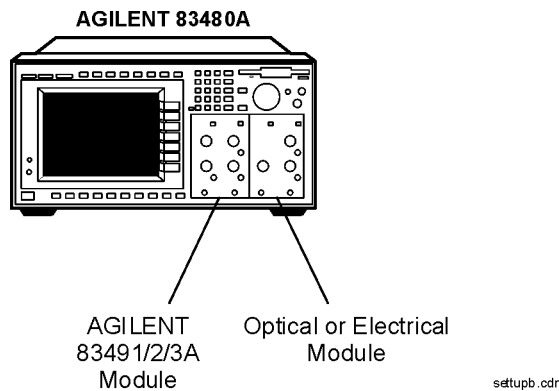

Figure 1-1. Serial number label

- 2 Install the Agilent 83491/2/3A module into the Agilent 83480A mainframe's left slot. Finger-tighten the knurled screw on the front panel of the plug-in module to ensure that the module is securely seated in the mainframe.

Note

Installing the module into the left slot ensures that the supplied adapter cable will fit. See [Figure 1-2](#).

Installation**Figure 1-2. Position of modules in the mainframe**

- 3 Clean all optical interfaces as described in [“Cleaning Connections for Accurate Measurements” on page 4-10](#), before making measurements.
- 4 Perform the following steps if you’re installing an Agilent 83492/3A module:
 - a Unscrew and remove the fiber-optic adapter that is located on the optical module’s front-panel optical input connector.
 - b Connect the adapter that was removed in the previous step onto the Agilent 83492/3A module’s front-panel Input connector.

On Agilent 83492A module’s, the input connector used depends on the wavelength of the input signal. Refer to [“To connect cables to an Agilent 83492A” on page 1-7](#).
- 5 Connect the supplied adapter cable as shown in [Figure 1-3](#).

WARNING

Light energy can radiate from the front panel OUTPUT connectors on Agilent 83492A and 83493A modules. The light emitted from these connectors is the slightly attenuated light that is input to the front-panel INPUT connector.

- 6 Turn on the Agilent 83480A, and connect a modulated signal to the Agilent 83491/2/3A module’s Input connector.

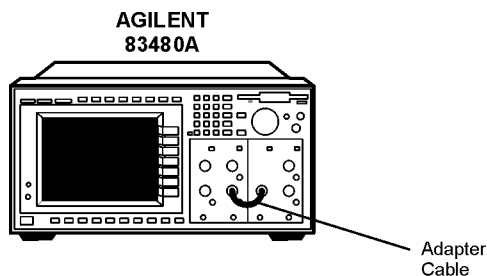

setupa

Figure 1-3. The adapter cable

CAUTION

Agilent 83491A Modules: Maximum safe signal input level is $\pm 5V$. The input circuits can also be damaged by electrostatic discharge (ESD). Before connecting any coaxial cable to the connectors, momentarily short the center and outer conductors of the cable together. Avoid touching the front-panel input connectors without first touching the frame of the instrument. Be sure that the instrument is properly earth-grounded to prevent buildup of static charge.

CAUTION

Agilent 83492/3A Modules: Maximum safe signal input level is +3 dBm.

- 7 On the Agilent 83480A, press the Trigger key and then the *Source* softkey. Then, select *trigger 2* (the Agilent 83491/2/3A module) for the trigger source.
- 8 On the Agilent 83491/2/3A module, repeatedly press the SELECT key until a front-panel light indicates the data rate of the signal. See [Figure 1-4 on page 1-6](#).

Green and red data-rate lights

The data-rate indicator lights change color between red and green to show which data rate is selected. A red light does *not* indicate a problem. A red light shows that the adjacent red data rate label is selected. A green light shows that the adjacent green data rate label is selected. Repeatedly pressing the SELECT key cycles through the selections in one color before switching to the opposite color. On Agilent 83491A modules for example, the first selection cycle shows 155 Mb/s selected. The second section cycle shows 1062 Mb/s selected.

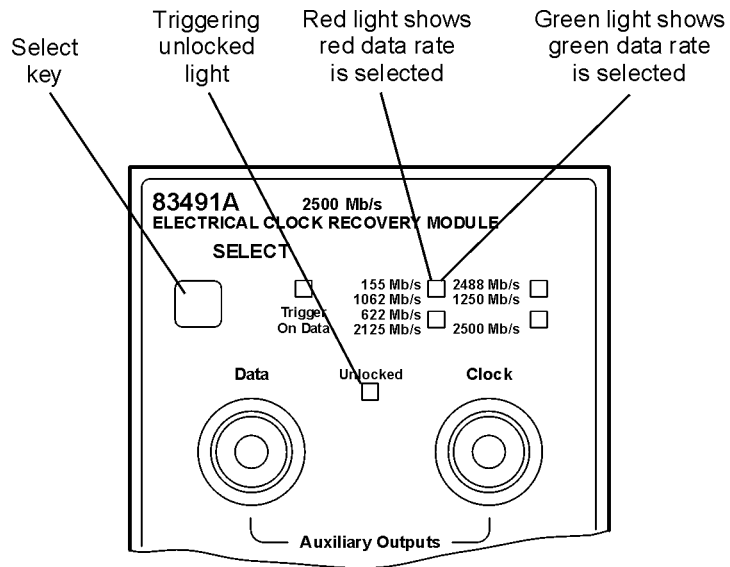
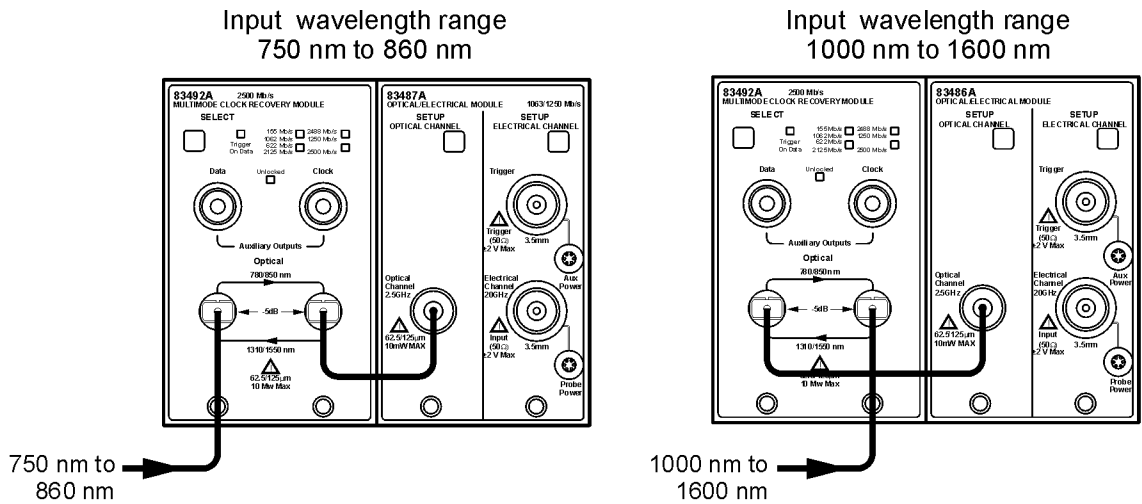

Figure 1-4. Front-panel lights

- 9 Confirm that the Unlocked light is off.
- 10 Observe the Clock and Data outputs on an oscilloscope. Waveforms should be present. The instrument is now ready for you to begin making measurements.

To connect cables to an Agilent 83492A

On Agilent 83492A modules, the front-panel fiber-optic connectors reverse input and output roles depending on the wavelength of the signal. Signals in the 750 nm to 860 nm wavelength range are input to the left connector and output from the right connector. Signals in the 1000 nm to 1600 nm wavelength range are input to the right connector and output from the left connector.



inoutoon.cdr

Figure 1-5. Input and output connections versus wavelength

Agilent 83491/2/3A Modules—At a Glance	2-2
Front-Panel Features	2-4
Block Diagrams	2-7
To Display a Signal	2-8
To Compensate for Module Insertion Loss	2-9
Using Probes with an Agilent 83491A	2-10
To compensate for a passive probe	2-11
To compensate an Agilent 54701A active probe	2-11
To compensate for other devices	2-12

Operation

Agilent 83491/2/3A Modules—At a Glance

The Agilent 83491/2/3A are designed to operate in an Agilent 83480A digital communications analyzer. These modules recover clock and data information at standard telecom and datacom rates. The resulting trigger signal is made available to the Agilent 83480A mainframe via a connector located on the module's rear-panel. An external front-panel cable passes the data signal, with some insertion loss, to the receiver module.

Table 2-1. Module Features

Agilent Module	Input Connector	Selectable Rates (Mb/s)
83491A	50 Ω electrical	155, 622, 1060, 1250, 2120, 2488, 2500
83492A	Multimode fiber (62.5/125 μm)	155, 622, 1060, 1250, 2120, 2488, 2500
83493A	Single-mode fiber (9/125 μm)	155, 622, 1250, 2488, 2500

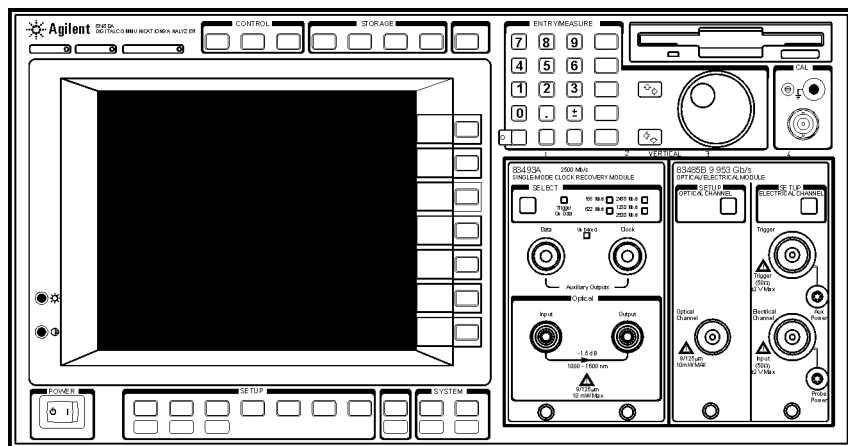

Figure 2-1. An Agilent 83493A installed in an Agilent 83480A mainframe

WARNING

Light energy can radiate from the front panel OUTPUT connectors on Agilent 83492A and 83493A modules. The light emitted from these connectors is the slightly attenuated light that is input to the front-panel INPUT connector.

Use with Agilent 71603B or 71612B Error Performance Analyzers

The front-panel Data and Clock outputs provide electrical recovered clock and regenerated data signals for simultaneous testing with other instruments, such as the Agilent 71603B or 71612B error performance analyzers.

Multimode module and single-mode reference receivers

Agilent Technologies does *not* recommend using the Agilent 83492A multimode module with single-mode reference receivers such as the Agilent 83481A, 83482A, or 83485A,B modules. Connecting multimode to single-mode fibers causes large reflections and insertion loss because of the reduction of the optical fiber's core from 62.5 μm to 9 μm .

Single-mode module and multimode reference receivers

It is acceptable to use an Agilent 83493A single-mode module with a multimode reference receiver such as the Agilent 83486A module. This is true provided that single-mode fiber is connected to the Agilent 83493A module's front-panel INPUT connector.

What you won't find on these modules....

Unlike other modules designed to be used with the Agilent 83480A digital communications analyzer, the Agilent 83491/2/3A modules do not include Channel keys or menus. Also, there are no GPIB programming commands for these modules.

Front-Panel Features

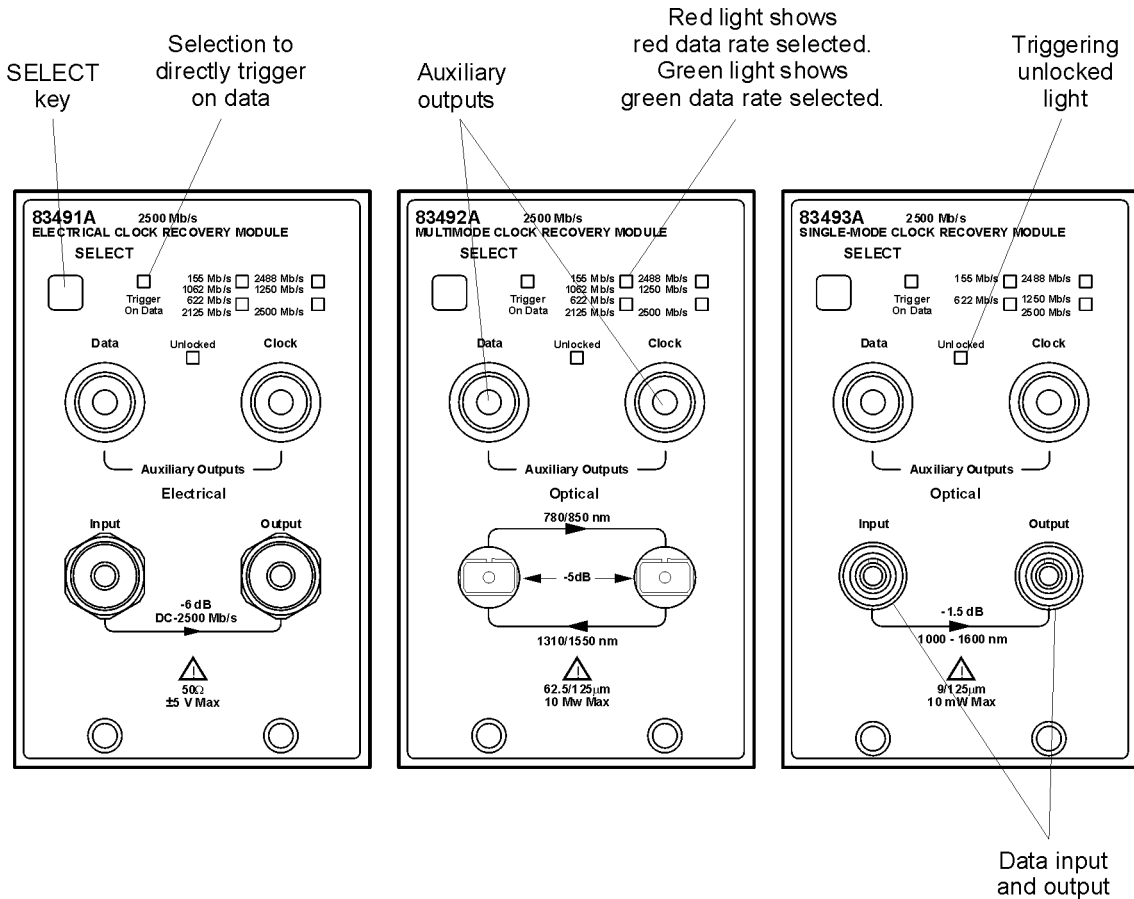

Figure 2-2. Agilent 83491/2/3A front panels

SELECT key

Pressing this key changes the modulation rate of the input signal. The recovered and retimed clock trigger is sent to the mainframe. The Trigger On Data selection is a bypass mode where the data stream directly triggers the mainframe. Refer to “Block Diagrams” on page 2-7 to view a schematic of the normal and bypass paths.

Green and red data-rate lights

The data-rate indicator lights change color between red and green to show which data rate is selected. A red light does *not* indicate a problem. A red light shows that the adjacent red data rate label is selected. A green light shows that the adjacent green data rate label is selected. Repeatedly pressing the SELECT key cycles through the selections in one color before switching to the opposite color. On Agilent 83491A modules for example, the first selection cycle shows 155 Mb/s selected. The second section cycle shows 1062 Mb/s selected.

UNLOCKED indicator

This light shows when clock recovery cannot be established on the signal. If a clock rate is selected, the trigger output to the mainframe *is* disabled to prevent free-run triggering. However in bypass mode (Trigger On Data selected), triggering is *not* disabled. When the UNLOCKED light is on, you can establish a trigger on the data input to the reference receiver.

Auxiliary outputs

DATA connector: This connector provides a fully regenerated version of the input signal. It is intended for monitoring purposes only and *not* for rigorous eye mask compliance testing. The frequency response does not conform to the requirements for eye mask testing as described in ITU-T G.957 and Bellcore GR-253-CORE. On Agilent 83492A and 83493A modules, this port is amplitude stabilized for input signals greater than approximately -23 dBm.

CLOCK connector: This connector provides the recovered clock signal. You can use this signal to measure jitter transfer, because this output can track and follow input data with very fast jitter; it has a wide bandwidth jitter transfer function when compared to the recovered clock signal which is routed through a rear-panel connector to the mainframe for triggering. Note that the CLOCK Auxiliary Output remains synchronized to input signals several dB below the onset of errors at the DATA Auxiliary Output.

Input and Output connectors

The input connectors pass the digitally modulated signal to the receiver module. The input signal, slightly attenuated and available at the OUTPUT connector, is connected to the input of any of the Agilent 83481,2,3,4,5,6, or 7 modules. The connectors on optical modules include adapters which can easily be changed to match the type of connectors that are used on your fiber-optic cables. Refer to “Front-Panel Optical Adapters” on page 4-2 for a description of the available adapters.

Front-Panel Features

Multimode and single-mode connections

Agilent 83492A modules use multimode fiber. Connecting the output to the Optical INPUT connector on Agilent 83481/2/5 single-mode modules results in large reflections and insertion loss.

Agilent 83493A modules use 9/125 μm single-mode fiber. Connecting multimode fiber to the Optical Input connector results in large reflections and insertion loss.

Recovered Clock The recovered clock signal is routed directly to the Agilent 83480A mainframe through the module's rear panel. This output has a lower jitter modulation bandwidth than the front-panel CLOCK Auxiliary Output. Because of the reduced jitter modulation bandwidth on the mainframe trigger signal, a more complete view of the jitter on the waveform data is obtained.

Block Diagrams

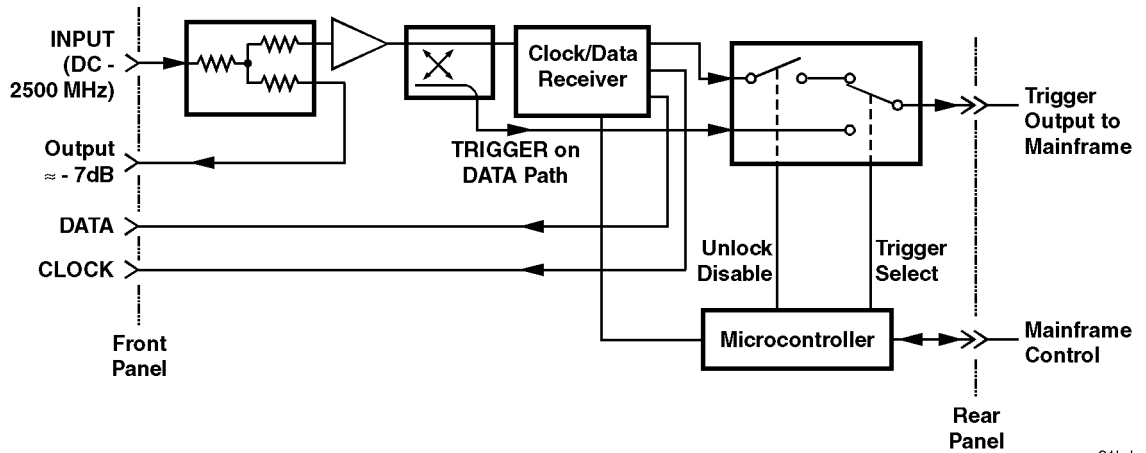

91bd

Figure 2-3. Agilent 83491A Block Diagram

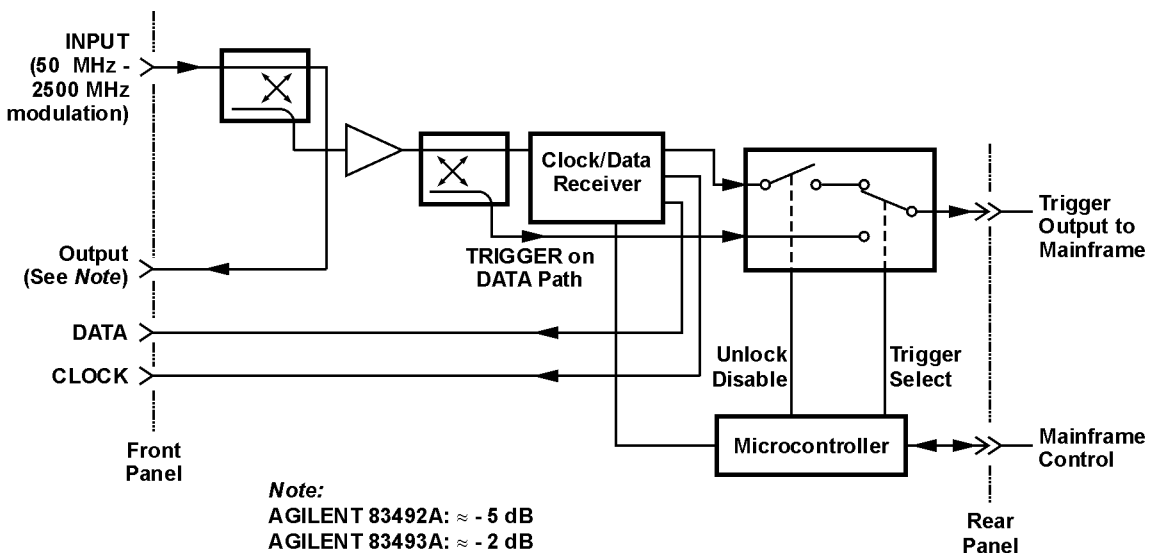

93bd

Figure 2-4. Agilent 83492A and 83493A Block Diagram

To Display a Signal

- 1 Install the module as described in “To install the module” on page 1-3. Be sure to connect all of the cables as described in the procedure.
- 2 Repeatedly press the SELECT key on the clock recovery module until the front-panel light indicates the proper data rate of the signal.

Green and red data-rate lights

The data-rate indicator lights change color between red and green to show which data rate is selected. A red light does *not* indicate a problem. A red light shows that the adjacent red data rate label is selected. A green light shows that the adjacent green data rate label is selected. Repeatedly pressing the SELECT key cycles through the selections in one color before switching to the opposite color. On Agilent 83491A modules for example, the first selection cycle shows 155 Mb/s selected. The second section cycle shows 1062 Mb/s selected.

- If the UNLOCKED light is on, clock recovery cannot be established on the signal.
- Avoid selecting a data rate that is a multiple of the input signal. For example, don't select a 622 Mb/s data rate if the signal is really at 155 Mb/s.
- If you cannot get the clock recovery module to lock on the signal, make sure that you have selected the correct data rate and that the Agilent 83480A (or Agilent 54750A) mainframe trigger level is adjusted appropriately.
- Signals displayed using a data trigger are less reliable than using a recovered clock. Signals triggered on data can also vary depending upon the trigger level.

To Compensate for Module Insertion Loss

The following steps allow you to enter an offset to compensate for the insertion loss of the clock recovery module. This provides accurate amplitude measurements at the input to the clock recovery module.

- 1** Disconnect the cable from the clock recovery module's input connector.
- 2** Measure the signal using a power meter. You can use either the Agilent 83480A's built-in power meter or an external power meter.
- 3** Reconnect the cable to the clock recovery module.
- 4** Disconnect the cable from the reference receiver module's input connector.
- 5** Measure the signal using a power meter. You can use either the Agilent 83480A's built-in power meter or an external power meter.
- 6** Subtract the two measurements to determine the insertion loss of the module.
Insertion loss: _____
- 7** On the *reference receiver module*, press the front-panel channel SETUP key.
- 8** Press *External scale*, and set the *Atten units* to "decibel".
- 9** Press *Attenuation*, and enter the value calculated in [Step 6](#).

Using Probes with an Agilent 83491A

You can use external passive and active probes with the Agilent 83491A electrical clock recovery module. The procedures in this section generate vertical scale factors. These factors are applied to the calibration of the reference receiver module's electrical channel. When selecting a probe, keep in mind that the input impedance of the Agilent 83491A is 50Ω .

If the probe being calibrated has an attenuation factor that allows the instrument to adjust the gain to produce even steps in the vertical scale factors, the instrument will do so. Typically, probes have standard attenuation factors such as divide by 10, divide by 20, or divide by 100.

Because the following procedures include compensation for insertion loss of the clock recovery module, do not perform the procedure "To Compensate for Module Insertion Loss" on page 2-9.

The following probes are available for use with Agilent 83491A clock recovery modules:

- Agilent N1020A TDR probe. This passive probe (1:1, 50Ω) provides a fixture for positioning and holding the probe tip on the device being tested.
- Agilent 54701A 2.5 GHz active probe. This is a $100k\Omega$, 10:1, probe.
- Agilent 54006A 6 GHz handheld low-impedance probe. This passive probe (10:1, 500Ω , 20:1, $1k\Omega$) has an input capacitance of 0.25 pf.
- Agilent 1163A 1 GHz resistive-divider probe. This passive 500Ω probe has an input capacitance of 1.5 pf.

To compensate for a passive probe

- 1** Connect the probe to the Input connector on the Agilent 83491A clock recovery module.
- 2** Attach the probe tip to the CAL hook that is located near the floppy disk drive.
- 3** Press the *reference receiver module's* front-panel channel SETUP key.
- 4** Press *Calibrate* and then *Calibrate probe*.

To compensate an Agilent 54701A active probe

- 1** Connect the Agilent 83491A output to the electrical measurement channel input.
- 2** Connect the probe to the Input connector on the Agilent 83491A clock recovery module.
- 3** Connect the probe power cable to the Probe Power connector on the reference receiver module.
- 4** Attach the probe tip to the CAL hook that is located near the floppy disk drive.
- 5** Press the *reference receiver module's* front-panel channel SETUP key.
- 6** Press *Calibrate* and then *Calibrate probe*.

To compensate for other devices

The information in this section applies to both optical and electrical measurements. Since the mainframe's CAL signal is a voltage source, it cannot be used to calibrate to the probe tip when the units are set to Ampere, Watt, or Unknown. Instead, set the external gain and external offset to compensate for the actual characteristics of the device. If you do not know the actual characteristics, you can refer to the typical specifications that came with the device.

- 1** Press the reference receiver module's front-panel channel SETUP key.
- 2** Press *External scale*.
- 3** Press *Atten units Ratio, Attenuation 1:1*, and then *Units Ampere* (Volt, Watt, or Unknown).
- 4** Press *Ext gain*, and enter the actual gain characteristics of the device.
- 5** Press *Ext offset*, and enter the offset introduced by the device.

Agilent 83491A Specifications 3-3
Agilent 83492A Specifications 3-4
Agilent 83493A Specifications 3-6
Agilent 83491/2/3A Operating Specifications 3-7
Declaration of Conformity 3-8

Specifications and Regulatory Information

Specifications and Regulatory Information

This chapter lists specifications and characteristics of the Agilent 83491/2/3A. Specifications apply over the temperature range +15°C to +35°C (unless otherwise noted) after the instrument's temperature has been stabilized after 60 minutes of continuous operation.

Specifications *Specifications* described warranted performance.

Characteristics *Characteristics* provide useful, nonwarranted, information about the functions and performance of the instrument. *Characteristics are printed in italics.*

Calibration cycle Agilent Technologies warrants instrument specifications over the recommended calibration interval. To maintain specifications, periodic recalibrations are necessary. We recommend that the Agilent 83491/2/3A be calibrated at an Agilent Technologies service facility every 24 months.

Agilent 83491A Specifications

Table 3-1. Agilent 83491A Specifications

Clock recovery rates (NRZ coding)	
155.52 Mb/s	±0.1%
622.08 Mb/s	±0.1%
1062.50 Mb/s	±0.1%
1250 Mb/s	±0.1%
2125.00 Mb/s	±0.1%
2488.32 Mb/s	±0.1%
2500.00 Mb/s	±0.1%
<i>Data triggering (characteristic)</i>	<i>50 Mb/s to 2500 Mb/s</i>
Operating input power level ^{a b}	
Triggering operation, all rates	-10 dBm to 3 dBm
10 ⁻¹⁰ BER, all rates ^c	-10 dBm to 3 dBm
Insertion loss (through path)	
DC through 2500 MHz	≤ 7 dB
Output jitter, all rates ^d	0.0125 UI _{rms}
<i>Maximum continuous electrical power before damage (characteristic)</i>	<i>1W peak</i>
<i>DATA and CLOCK output amplitude, all rates (characteristic)</i>	<i>0.5Vp-p</i>
<i>INPUT electrical return loss</i>	
<i>DC through 1250 MHz (characteristic)</i>	<i>≥ 20 dB</i>
<i>1250 MHz through 2500 MHz (characteristic)</i>	<i>≥ 15 dB</i>
<i>DATA and CLOCK electrical return loss</i>	
<i>50 MHz through 2000 MHz (characteristic)</i>	<i>≥ 10 dB</i>
<i>2000 MHz through 2500 MHz (characteristic)</i>	<i>≥ 6 dB</i>

- a. Source extinction ratio ≥ 8.2 dB when measured per TIA/EIA OFSTP-4A.
 b. Operating power level applies over temperature range 25°C ± 5°.
 c. Better than 10⁻¹⁰ BER when tested with PRBS 2²³-1 pattern.
 d. Measured on an oscilloscope eye diagram with PRBS 2²³-1 test pattern.

Agilent 83492A Specifications

Table 3-2. Agilent 83492A Specifications (1 of 2)

<i>Wavelength range (characteristic)</i>	<i>750 nm to 860 nm and 1000 nm to 1600 nm</i>
<i>Optical INPUT and OUTPUT fiber (characteristic)</i>	<i>62.5/125 multimode</i>
Optical insertion loss (through path) ^a	
750 nm to 860 nm	≤ 5.0 dB
1000 nm to 1600 nm	≤ 5.0 dB
Optical return loss ^b	≥ 28 dB
Clock recovery rates (NRZ coding)	
155.52 Mb/s	±0.1%
622.08 Mb/s	±0.1%
1062.50 Mb/s	±0.1%
1250 Mb/s	±0.1%
2125.00 Mb/s	±0.1%
2488.32 Mb/s	±0.1%
2500.00 Mb/s	±0.1%
<i>Data triggering (characteristic)</i>	<i>50 Mb/s to 2500 Mb/s</i>
Operating input power level ^{c d}	
750 nm to 860 nm	
Triggering operation, all rates	–10 dBm to 3 dBm
10 ⁻¹⁰ BER, all rates ^e	–10 dBm to 3 dBm
1000 nm to 1600 nm	
Triggering operation, all rates	–13 dBm to 3 dBm
10 ⁻¹⁰ BER, all rates ^f	–13 dBm to 3 dBm
Output jitter, all rates ^g	0.0125 UI _{rms}
<i>Maximum continuous optical power before damage (characteristic)</i>	<i>10 mW peak</i>
<i>DATA and CLOCK output amplitude, all rates (characteristic)</i>	<i>0.5Vp-p</i>

Table 3-2. Agilent 83492A Specifications (2 of 2)*DATA and CLOCK electrical return loss*

<i>50 MHz through 2000 MHz (characteristic)</i>	≥ 10 dB
<i>2000 MHz through 2500 MHz (characteristic)</i>	≥ 6 dB

- a. Minimum loss in 850 nm window.
- b. Single-mode backreflection tested with FC/PC adapter and single-mode fiber. Optical output terminated with > 33 dB return loss. Return loss with fully filled 62.5 μm core multimode fiber may be slightly lower.
- c. Source extinction ratio ≥ 8.2 dB when measured per TIA/EIA OFSTP-4A.
- d. Operating power level applies over temperature range $25^{\circ}\text{C} \pm 5^{\circ}$.
- e. Better than 10^{-10} BER when tested with PRBS $2^{23}-1$ pattern.
- f. Better than 10^{-10} BER when tested with PRBS $2^{23}-1$ pattern.
- g. Measured on an oscilloscope eye diagram with PRBS $2^{23}-1$ test pattern.

Agilent 83493A Specifications

Table 3-3. Agilent 83493A Specifications

<i>Wavelength range (characteristic)</i>	<i>1000 nm to 1600 nm</i>
<i>Optical INPUT fiber (characteristic)</i>	<i>9/125 single mode</i>
Optical insertion loss (through path)	≤ 1.5 dB
Optical return loss ^a	≥ 28 dB
Clock recovery rates (NRZ coding)	
155.52 Mb/s	±0.1%
622.08 Mb/s	±0.1%
1250 Mb/s	±0.1%
2488.32 Mb/s	±0.1%
2500.00 Mb/s	±0.1%
<i>Data triggering (characteristic)</i>	<i>50 Mb/s to 2500 Mb/s</i>
Operating input power level ^{b c}	
Triggering operation, all rates	–20 dBm to 3 dBm
10 ^{–10} BER, all rates ^d	–17 dBm to 3 dBm
Output jitter, all rates ^e	0.0125 UI _{rms}
<i>Maximum continuous optical power before damage (characteristic)</i>	<i>10 mW peak</i>
<i>DATA and CLOCK output amplitude, all rates (characteristic)</i>	<i>0.5Vp-p</i>
<i>DATA and CLOCK output electrical return loss</i>	
50 MHz through 2000 MHz (characteristic)	≥ 10 dB
2000 MHz through 2500 MHz (characteristic)	≥ 6 dB

a. Tested with FC/PC adapter. Optical output terminated without > 33 dB return loss.

b. Source extinction ratio ≥ 8.2 dB when measured per TIA/EIA OFSTP-4A.

c. Operating power level applies over temperature range 25°C ± 5°C.

d. Better than 10^{–10} BER when tested with PRBS 2²³–1 pattern.

e. Measured on an oscilloscope eye diagram with PRBS 2²³–1 test pattern.

Agilent 83491/2/3A Operating Specifications

Table 3-4. Agilent 83491/2/3A Operating Specifications

Use	Indoor
Temperature	
Operating	0°C to +55°C
Non-operating	-40°C to +70°C
Altitude	
Operating	4600 m (15,000 ft)
Non-operating	15,300 m (50,000 ft)
Humidity	
Operating	up to 90% relative humidity at <35°C
Non-operating	up to 90% relative humidity at <35°C
Net weight	approximately 1.2 kg (2.6 lb.)
Shipping weight	approximately 2.1 kg (4.6 lb.)
Power Requirements	Supplied by mainframe

Declaration of Conformity







Declaration of Conformity

DECLARATION OF CONFORMITY <small>According to ISO/IEC Guide 22 and EN 45014</small>	
Manufacturer's Name:	Hewlett-Packard Co.
Manufacturer's Address:	1400 Fountaingrove Parkway Santa Rosa, CA 95403-1799 USA
Declares that the product:	
Product Name:	Clock Recovery/Trigger Module
Model Number:	HP 83491A, HP 83492A, HP 83493A
Product Options:	This declaration covers all options of the above product.
Conforms to the following product specifications:	
Safety: IEC 61010-1:1990 / EN 61010-1:1993 CAN/CSA-C22.2 No. 1010.1-92	
EMC: CISPR 11:1990/EN 55011:1991 Group 1, Class A IEC 801-2:1984/EN 50082-1:1992 4 kV CD, 8 kV AD IEC 801-3:1984/EN 50082-1:1992 3 V/m, 27-500 MHz IEC 801-4:1988/EN 50082-1:1992 0.5 kV sig. lines, 1 kV power lines	
Supplementary Information:	
The product herewith complies with the requirements of the Low Voltage Directive 73/23/EEC and the EMC Directive 89/336/EEC and carries the CE-marking accordingly.	
Santa Rosa, CA, USA	June 10, 1999
	 Greg Pfeiffer/Quality Engineering Manager
<small>European Contact: Your local Hewlett-Packard Sales and Service Office or Hewlett-Packard GmbH Department HQ-TRE, Herrenerberger Strasse 130, D71034 Boblingen, Germany (FAX +49-7031-14-3143)</small>	

Front-Panel Optical Adapters	4-2
In Case of Difficulty	4-3
Error Messages	4-5
Electrostatic Discharge Information	4-8
Cleaning Connections for Accurate Measurements	4-10
Returning the Instrument for Service	4-20
Agilent Technologies Service Offices	4-23

Reference

Front-Panel Optical Adapters

Front Panel Fiber-Optic Adapter	Description	Agilent Part Number
	Diamond HMS-10	81000AI
	FC/PC ^a	81000FI
	D4	81000GI
	SC	81000KI
	DIN	81000SI
	ST	81000VI
	Biconic	81000WI
Dust Covers		
FC connector		1005-0594
Diamond HMS-10 connector		1005-0593
DIN connector		1005-0595
ST connector		1005-0596
SC connector		1005-0597

a. The FC/PC adapter is the standard adapter supplied with the instrument.

In Case of Difficulty

This section provides a list of suggestions for you to follow if the plug-in module fails to operate. A list of messages that may be displayed is also included in this chapter. Before calling Agilent Technologies or returning the unit for service, a few minutes spent performing some simple checks may save waiting for your instrument to be repaired.

If the mainframe does not operate

- Is the line fuse good?
- Does the line socket have power?
- Is the unit plugged in to the proper ac power source?
- Is the mainframe turned on?
- Is the rear-panel line switch set to on?
- Will the mainframe power up *without* the plug-in module installed?

If the mainframe still does not power up, refer to the optional *Agilent 83480A, Agilent 54750A Service Guide* or return the mainframe to a qualified service department.

If the plug-in does not operate

- Is the plug-in module firmly seated in the mainframe slot?
- Are the knurled screws at the bottom of the plug-in module finger-tight?
- Is the clock recovery module set to the modulation rate of the input signal?
- If other equipment, cables, and connectors are being used with the plug-in module, are they connected properly and operating correctly?
- Review the procedure for the test being performed when the problem ap-

In Case of Difficulty

peared. Are all the settings correct? Can the problem be reproduced?

- ❑ Are the connectors clean? See [“Cleaning Connections for Accurate Measurements” on page 4-10](#) for more information.
- ❑ Perform the following procedures:
 - 1 Make sure that the instrument is ready to acquire data by pressing Run.
 - 2 Find any signals on the channel inputs by pressing Autoscale.
 - 3 See if any signals are present at the channel inputs by pressing Trigger, *Sweep*, *Freerun*.
 - 4 After viewing the signal, press *triggered*.
 - 5 Make sure Channel Display is on by pressing Channel, *Display on off*, *on*.
 - 6 Make sure the channel offset is adjusted so the waveform is not clipped off the display.
 - 7 Make sure the mainframe identifies the plug-in module by pressing Utility, then *System config...*

The calibration status of the plug-in modules is listed near the bottom of the display, in the box labeled “Plug-ins”. If the model number of the plug-in module is listed next to the appropriate slot number, then the mainframe has identified the plug-in.

If “~known” is displayed instead of the model number of the plug-in module, remove and reinsert the plug-in module in the same slot.

If “~known” is still displayed, the mainframe may need to have the latest operating system firmware installed. Options 001 and 002 provide this firmware on a 3.5 inch diskette. To load new firmware, follow the instructions provided with this diskette. If you do not have the optional diskette, contact your local Agilent Technologies service office (refer to “Agilent Technologies Service Offices” on page 4-23).

If the mainframe firmware is current and the plug-in module is correctly installed, then the memory contents of the plug-in module are corrupt. Contact a qualified service department.

Error Messages

The following error messages are for the plug-in module. Typically, the error messages indicate there is a problem with either the plug-in or the mainframe. This section explains what the messages mean and offers a few suggestions that might help resolve the error condition. If the suggestions do not eliminate the error message, then additional troubleshooting is required that is beyond the scope of this book. Additional error messages are listed in the *Agilent 83480A, Agilent 54750A User's Guide* for the mainframe.

Memory error occurred in plug-in_:Try reinstalling plug-in

The mainframe could not correctly read the contents of the memory in the plug-in.

- Remove and reinstall the plug-in module. Each time a plug-in is installed, the mainframe re-reads the memory in the plug-in module.
- Verify the plug-in module is firmly seated in the mainframe slot.
- Verify the knurled screws at the bottom of the plug-in module are finger-tight.
- Install the plug-in in a different slot in the mainframe.

Busy timeout occurred with plug-in_:Try reinstalling plug-in

Busy timeout occurred with plug-in_:Try reinstalling plug-in

The mainframe is having trouble communicating with the plug-in module. Make sure there is a good connection between the mainframe and the plug-in module.

- Remove and reinstall the plug-in module.
 - Verify the plug-in module is firmly seated in the mainframe slot.
 - Verify the knurled screws at the bottom of the plug-in module are finger-tight.
 - Install the plug-in in a different slot in the mainframe.
-

Communications failure exists at slot_:Service is required

An illegal hardware state is detected at the mainframe-to-plug-in module interface of the specified slot.

- If the slot is empty, there is a mainframe hardware problem. Refer to the *Agilent 83480A, Agilent 54750A Service Guide*.
 - If a plug-in is installed in the slot, there is a plug-in module hardware problem. Return the plug-in module to a qualified service department.
-

ID error occurred in plug-in_:Service is required

The information read from the memory of the plug-in module does not match the hardware in the plug-in module. This can be caused by a communication problem between the mainframe and the plug-in module. Make sure there is a good connection between the mainframe and the plug-in.

- Remove and re-install the plug-in module.
 - Verify the plug-in module is firmly seated in the mainframe slot.
 - Verify the knurled screws at the bottom of the plug-in module are finger tight.
 - The standard Agilent 54750A mainframe does not accept the Agilent 83491/2/3A module. To use the module, a firmware upgrade must first be installed. Or-
-

Plug-in is not supported: System firmware upgrade is needed

der the Agilent 83480K communications firmware kit and install according to the instructions.

- The Agilent 83480A, Agilent 54750A mainframes do not accept plug-in modules designed for use with the Agilent 54710A, 54720A.

Plug-in is not supported: System firmware upgrade is needed

The mainframe may need to have the latest operating system firmware installed. Options 001 and 002 provide this firmware on a 3.5 inch diskette. To load the new firmware, follow the instructions provided with the diskette. If you do not have the optional diskette, contact your local Agilent Technologies service office.

Electrostatic Discharge Information

Electrostatic discharge (ESD) can damage or destroy electronic components. All work on electronic assemblies should be performed at a static-safe work station. The following figure shows an example of a static-safe work station using two types of ESD protection:

- Conductive table-mat and wrist-strap combination.
- Conductive floor-mat and heel-strap combination.

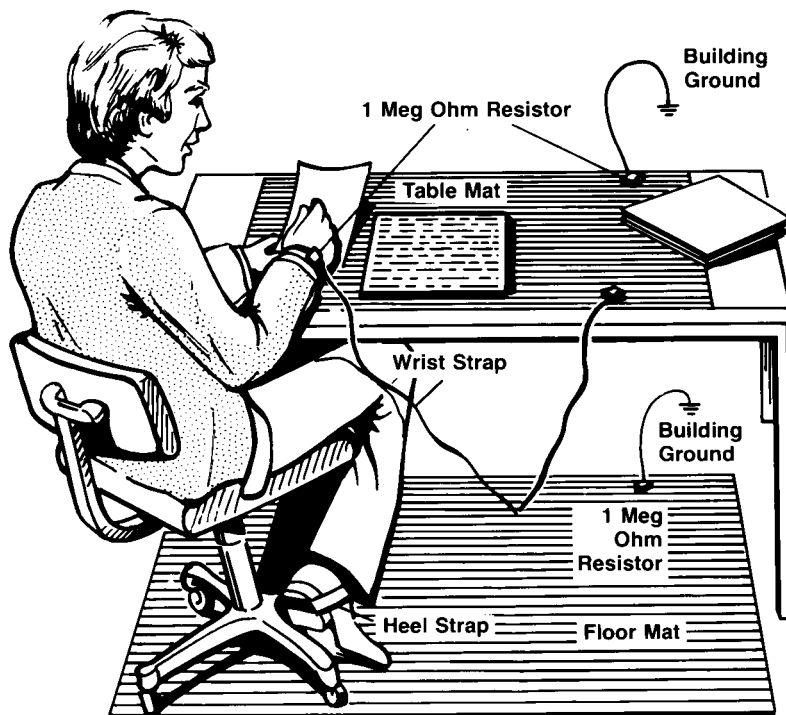

Figure 4-1. Static-safe work station

Both types, when used together, provide a significant level of ESD protection. Of the two, only the table-mat and wrist-strap combination provides adequate ESD protection when used alone.

To ensure user safety, the static-safe accessories must provide at least 1 M Ω of isolation from ground. Refer to [Table 4-1](#) for information on ordering static-safe accessories.

WARNING

These techniques for a static-safe work station should not be used when working on circuitry with a voltage potential greater than 500 volts.

Reducing ESD Damage

The following suggestions may help reduce ESD damage that occurs during testing and servicing operations.

- Personnel should be grounded with a resistor-isolated wrist strap before removing any assembly from the unit.
- Be sure all instruments are properly earth-grounded to prevent a buildup of static charge.

Table 4-1. Static-Safe Accessories

Agilent Part Number	Description
9300-0797	Set includes: 3M static control mat 0.6 m \times 1.2 m (2 ft \times 4 ft) and 4.6 cm (15 ft) ground wire. (The wrist-strap and wrist-strap cord are not included. They must be ordered separately.)
9300-0980	Wrist-strap cord 1.5 m (5 ft)
9300-1383	Wrist-strap, color black, stainless steel, without cord, has four adjustable links and a 7 mm post-type connection.
9300-1169	ESD heel-strap (reusable 6 to 12 months).

Cleaning Connections for Accurate Measurements

Today, advances in measurement capabilities make connectors and connection techniques more important than ever. Damage to the connectors on calibration and verification devices, test ports, cables, and other devices can degrade measurement accuracy and damage instruments. Replacing a damaged connector can cost thousands of dollars, not to mention lost time! This expense can be avoided by observing the simple precautions presented in this book. This book also contains a brief list of tips for caring for electrical connectors.

Choosing the Right Connector

A critical but often overlooked factor in making a good lightwave measurement is the selection of the fiber-optic connector. The differences in connector types are mainly in the mechanical assembly that holds the ferrule in position against another identical ferrule. Connectors also vary in the polish, curve, and concentricity of the core within the cladding. Mating one style of cable to another requires an adapter. Agilent Technologies offers adapters for most instruments to allow testing with many different cables. Figure 4-2 on page 4-11 shows the basic components of a typical connectors.

The system tolerance for reflection and insertion loss must be known when selecting a connector from the wide variety of currently available connectors. Some items to consider when selecting a connector are:

- How much insertion loss can be allowed?
- Will the connector need to make multiple connections? Some connectors are better than others, and some are very poor for making repeated connections.
- What is the reflection tolerance? Can the system take reflection degradation?
- Is an instrument-grade connector with a precision core alignment required?
- Is repeatability tolerance for reflection and loss important? Do your specifica-

Cleaning Connections for Accurate Measurements

tions take repeatability uncertainty into account?

- Will a connector degrade the return loss too much, or will a fusion splice be required? For example, many DFB lasers cannot operate with reflections from connectors. Often as much as 90 dB isolation is needed.

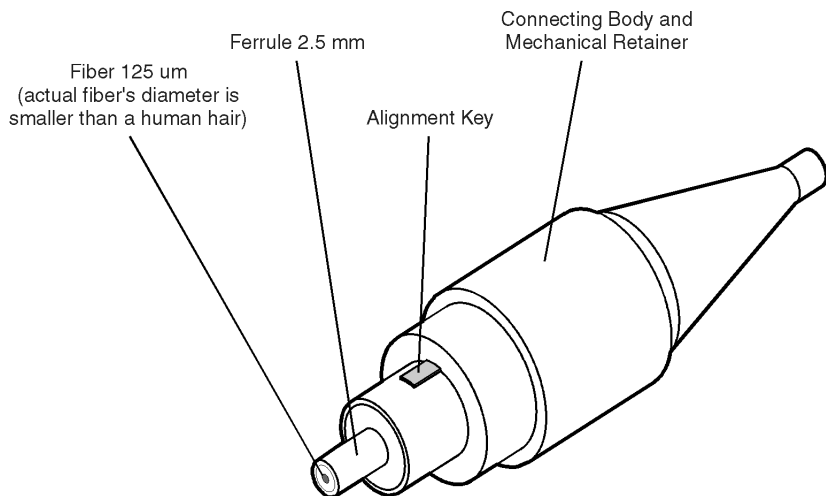

Figure 4-2. Basic components of a connector.

Over the last few years, the FC/PC style connector has emerged as the most popular connector for fiber-optic applications. While not the highest performing connector, it represents a good compromise between performance, reliability, and cost. If properly maintained and cleaned, this connector can withstand many repeated connections.

However, many instrument specifications require tighter tolerances than most connectors, including the FC/PC style, can deliver. These instruments cannot tolerate connectors with the large non-concentricities of the fiber common with ceramic style ferrules. When tighter alignment is required, Agilent Technologies instruments typically use a connector such as the Diamond HMS-10, which has concentric tolerances within a few tenths of a micron. Agilent Technologies then uses a special universal adapter, which allows other cable types to mate with this precision connector. See Figure 4-3.

Cleaning Connections for Accurate Measurements**Figure 4-3. Universal adapters to Diamond HMS-10.**

The HMS-10 encases the fiber within a soft nickel silver (Cu/Ni/Zn) center which is surrounded by a tough tungsten carbide casing, as shown in Figure 4-4.

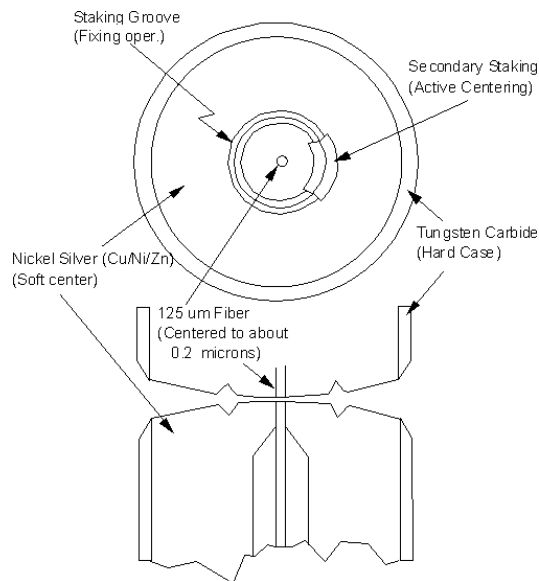
**Figure 4-4. Cross-section of the Diamond HMS-10 connector.**

The nickel silver allows an active centering process that permits the glass fiber to be moved to the desired position. This process first stakes the soft nickel silver to fix the fiber in a near-center location, then uses a post-active staking to shift the fiber into the desired position within 0.2 μm. This process, plus the keyed axis, allows very precise core-to-core alignments. This connector is found on most Agilent Technologies lightwave instruments.

Cleaning Connections for Accurate Measurements

The soft core, while allowing precise centering, is also the chief liability of the connector. The soft material is easily damaged. Care must be taken to minimize excessive scratching and wear. While minor wear is not a problem if the glass face is not affected, scratches or grit can cause the glass fiber to move out of alignment. Also, if unkeyed connectors are used, the nickel silver can be pushed onto the glass surface. Scratches, fiber movement, or glass contamination will cause loss of signal and increased reflections, resulting in poor return loss.

Inspecting Connectors

Because fiber-optic connectors are susceptible to damage that is not immediately obvious to the naked eye, poor measurements result without the user being aware. Microscopic examination and return loss measurements are the best way to ensure good measurements. Good cleaning practices can help ensure that optimum connector performance is maintained. With glass-to-glass interfaces, any degradation of a ferrule or the end of the fiber, any stray particles, or finger oil can have a significant effect on connector performance. Where many repeat connections are required, use of a connector saver or patch cable is recommended.

Figure 4-5 shows the end of a clean fiber-optic cable. The dark circle in the center of the micrograph is the fiber's 125 μm core and cladding which carries the light. The surrounding area is the soft nickel-silver ferrule. Figure 4-6 shows a dirty fiber end from neglect or perhaps improper cleaning. Material is smeared and ground into the end of the fiber causing light scattering and poor reflection. Not only is the precision polish lost, but this action can grind off the glass face and destroy the connector.

Figure 4-7 shows physical damage to the glass fiber end caused by either repeated connections made without removing loose particles or using improper cleaning tools. When severe, the damage of one connector end can be transferred to another good connector endface that comes in contact with the damaged one. Periodic checks of fiber ends, and replacing connecting cables after many connections is a wise practice.

The cure for these problems is disciplined connector care as described in the following list and in "Cleaning Connectors" on page 4-17.

Cleaning Connections for Accurate Measurements

Use the following guidelines to achieve the best possible performance when making measurements on a fiber-optic system:

- Never use metal or sharp objects to clean a connector and never scrape the connector.
- Avoid matching gel and oils.

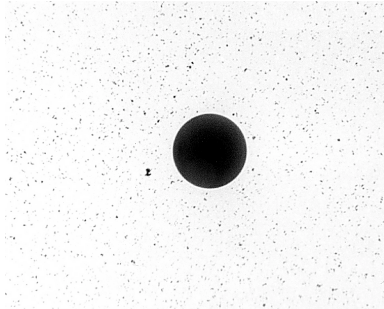

Figure 4-5. Clean, problem-free fiber end and ferrule.

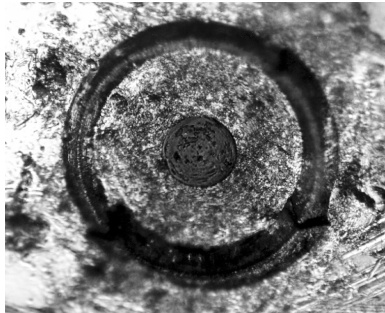

Figure 4-6. Dirty fiber end and ferrule from poor cleaning.



Figure 4-7. Damage from improper cleaning.

While these often work well on first insertion, they are great dirt magnets. The oil or gel grabs and holds grit that is then ground into the end of the fiber. Also, some early gels were designed for use with the FC, non-contacting connectors, using small glass spheres. When used with contacting connectors, these glass balls can scratch and pit the fiber. If an index matching gel or oil must be used, apply it to a freshly cleaned connector, make the measurement, and then immediately clean it off. Never use a gel for longer-term connections and never use it to improve a damaged connector. The gel can mask the extent of damage and continued use of a damaged fiber can transfer damage to the instrument.

- When inserting a fiber-optic cable into a connector, gently insert it in as straight a line as possible. Tipping and inserting at an angle can scrape material off the inside of the connector or even break the inside sleeve of connectors made with ceramic material.
- When inserting a fiber-optic connector into a connector, make sure that the fiber end does not touch the outside of the mating connector or adapter.
- Avoid over tightening connections.

Unlike common electrical connections, tighter is *not* better. The purpose of the connector is to bring two fiber ends together. Once they touch, tightening only causes a greater force to be applied to the delicate fibers. With connectors that have a convex fiber end, the end can be pushed off-axis resulting in misalignment and excessive return loss. Many measurements are actually improved by backing off the connector pressure. Also, if a piece of grit does happen to get by the cleaning procedure, the tighter connection is more likely to damage the glass. Tighten the connectors just until the two fibers touch.

Cleaning Connections for Accurate Measurements

- Keep connectors covered when not in use.
- Use fusion splices on the more permanent critical nodes. Choose the best connector possible. Replace connecting cables regularly. Frequently measure the return loss of the connector to check for degradation, and clean every connector, every time.

All connectors should be treated like the high-quality lens of a good camera. The weak link in instrument and system reliability is often the inappropriate use and care of the connector. Because current connectors are so easy to use, there tends to be reduced vigilance in connector care and cleaning. It takes only one missed cleaning for a piece of grit to permanently damage the glass and ruin the connector.

Measuring insertion loss and return loss

Consistent measurements with your lightwave equipment are a good indication that you have good connections. Since return loss and insertion loss are key factors in determining optical connector performance they can be used to determine connector degradation. A smooth, polished fiber end should produce a good return-loss measurement. The quality of the polish establishes the difference between the “PC” (physical contact) and the “Super PC” connectors. Most connectors today are physical contact which make glass-to-glass connections, therefore it is critical that the area around the glass core be clean and free of scratches. Although the major area of a connector, excluding the glass, may show scratches and wear, if the glass has maintained its polished smoothness, the connector can still provide a good low level return loss connection.

If you test your cables and accessories for insertion loss and return loss upon receipt, and retain the measured data for comparison, you will be able to tell in the future if any degradation has occurred. Typical values are less than 0.5 dB of loss, and sometimes as little as 0.1 dB of loss with high performance connectors. Return loss is a measure of reflection: the less reflection the better (the larger the return loss, the smaller the reflection). The best physically contacting connectors have return losses better than 50 dB, although 30 to 40 dB is more common.

Visual inspection of fiber ends

Visual inspection of fiber ends can be helpful. Contamination or imperfections on the cable end face can be detected as well as cracks or chips in the fiber itself. Use a microscope (100X to 200X magnification) to inspect the entire end face for contamination, raised metal, or dents in the metal as well as any other imperfections. Inspect the fiber for cracks and chips. Visible imperfections not touching the fiber core may not affect performance (unless the imperfections keep the fibers from contacting).

WARNING

Always remove both ends of fiber-optic cables from any instrument, system, or device before visually inspecting the fiber ends. Disable all optical sources before disconnecting fiber-optic cables. Failure to do so may result in permanent injury to your eyes.

Cleaning Connectors

The procedures in this section provide the proper steps for cleaning fiber-optic cables and Agilent Technologies universal adapters. The initial cleaning, using the alcohol as a solvent, gently removes any grit and oil. If a caked-on layer of material is still present, (this can happen if the beryllium-copper sides of the ferrule retainer get scraped and deposited on the end of the fiber during insertion of the cable), a second cleaning should be performed. It is not uncommon for a cable or connector to require more than one cleaning.

CAUTION

Agilent Technologies strongly recommends that index matching compounds *not* be applied to their instruments and accessories. Some compounds, such as gels, may be difficult to remove and can contain damaging particulates. If you think the use of such compounds is necessary, refer to the compound manufacturer for information on application and cleaning procedures.

Table 4-2. Cleaning Accessories

Item	Agilent Part Number
Any commercially available denatured alcohol	—
Cotton swabs	8520-0023
Small foam swabs	9300-1223
Compressed dust remover (non-residue)	8500-5262

Table 4-3. Dust Caps Provided with Lightwave Instruments

Item	Agilent Part Number
Laser shutter cap	08145-64521
FC/PC dust cap	08154-44102
Biconic dust cap	08154-44105
DIN dust cap	5040-9364
HMS10/dust cap	5040-9361
ST dust cap	5040-9366

To clean a non-lensed connector**CAUTION**

Do not use any type of foam swab to clean optical fiber ends. Foam swabs can leave filmy deposits on fiber ends that can degrade performance.

- 1** Apply pure isopropyl alcohol to a clean lint-free cotton swab or lens paper.
Cotton swabs can be used as long as no cotton fibers remain on the fiber end after cleaning.
- 2** Clean the ferrules and other parts of the connector while avoiding the end of the fiber.
- 3** Apply isopropyl alcohol to a new clean lint-free cotton swab or lens paper.
- 4** Clean the fiber end with the swab or lens paper.
Do *not* scrub during this initial cleaning because grit can be caught in the swab and become a gouging element.
- 5** Immediately dry the fiber end with a clean, dry, lint-free cotton swab or lens paper.
- 6** Blow across the connector end face from a distance of 6 to 8 inches using filtered, dry, compressed air. Aim the compressed air at a shallow angle to the fiber end face.

Nitrogen gas or compressed dust remover can also be used.

CAUTION

Do not shake, tip, or invert compressed air canisters, because this releases particles in the can into the air. Refer to instructions provided on the compressed air canister.

- 7 As soon as the connector is dry, connect or cover it for later use.

If the performance, after the initial cleaning, seems poor try cleaning the connector again. Often a second cleaning will restore proper performance. The second cleaning should be more arduous with a scrubbing action.

To clean an adapter

The fiber-optic input and output connectors on many Agilent Technologies instruments employ a universal adapter such as those shown in the following picture. These adapters allow you to connect the instrument to different types of fiber-optic cables.



Figure 4-8. Universal adapters.

- 1 Apply isopropyl alcohol to a clean foam swab.

Cotton swabs can be used as long as no cotton fibers remain after cleaning. The foam swabs listed in this section's introduction are small enough to fit into adapters.

Although foam swabs can leave filmy deposits, these deposits are very thin, and the risk of other contamination buildup on the inside of adapters greatly outweighs the risk of contamination by foam swabs.

- 2 Clean the adapter with the foam swab.
- 3 Dry the inside of the adapter with a clean, dry, foam swab.
- 4 Blow through the adapter using filtered, dry, compressed air.

Nitrogen gas or compressed dust remover can also be used. Do not shake, tip, or invert compressed air canisters, because this releases particles in the can into the air. Refer to instructions provided on the compressed air canister.

Returning the Instrument for Service

The instructions in this section show you how to properly return the instrument for repair or calibration. Always call the Agilent Technologies Instrument Support Center first to initiate service *before* returning your instrument to a service office. This ensures that the repair (or calibration) can be properly tracked and that your instrument will be returned to you as quickly as possible. Call this number regardless of where you are located. Refer to “Agilent Technologies Service Offices” on page 4-23 for a list of service offices.

Agilent Technologies Instrument Support Center (800) 403-0801

If the instrument is still under warranty or is covered by an Agilent Technologies maintenance contract, it will be repaired under the terms of the warranty or contract (the warranty is at the front of this manual). If the instrument is no longer under warranty or is not covered by an Agilent Technologies maintenance plan, Agilent Technologies will notify you of the cost of the repair after examining the unit.

When an instrument is returned to a Agilent Technologies service office for servicing, it must be adequately packaged and have a complete description of the failure symptoms attached. When describing the failure, please be as specific as possible about the nature of the problem. Include copies of additional failure information (such as the instrument failure settings, data related to instrument failure, and error messages) along with the instrument being returned.

Preparing the instrument for shipping

- 1 Write a complete description of the failure and attach it to the instrument. Include any specific performance details related to the problem. The following

information should be returned with the instrument.

- Type of service required.
 - Date instrument was returned for repair.
 - Description of the problem:
 - Whether problem is constant or intermittent.
 - Whether instrument is temperature-sensitive.
 - Whether instrument is vibration-sensitive.
 - Instrument settings required to reproduce the problem.
 - Performance data.
 - Company name and return address.
 - Name and phone number of technical contact person.
 - Model number of returned instrument.
 - Full serial number of returned instrument.
 - List of any accessories returned with instrument.
- 2** Cover all front or rear-panel connectors that were originally covered when you first received the instrument.

CAUTION

Cover electrical connectors to protect sensitive components from electrostatic damage. Cover optical connectors to protect them from damage due to physical contact or dust.

CAUTION

Instrument damage can result from using packaging materials other than the original materials. Never use styrene pellets as packaging material. They do not adequately cushion the instrument or prevent it from shifting in the carton. They may also cause instrument damage by generating static electricity.

- 3** Pack the instrument in the original shipping containers. Original materials are available through any Agilent Technologies office. Or, use the following guidelines:
- Wrap the instrument in antistatic plastic to reduce the possibility of damage caused by electrostatic discharge.
 - For instruments weighing less than 54 kg (120 lb), use a double-walled, corrugated cardboard carton of 159 kg (350 lb) test strength.
 - The carton must be large enough to allow approximately 7 cm (3 inches) on all sides of the instrument for packing material, and strong enough to accommodate the weight of the instrument.
 - Surround the equipment with approximately 7 cm (3 inches) of packing material, to protect the instrument and prevent it from moving in the carton. If packing foam is not available, the best alternative is S.D-240 Air Cap™ from

Returning the Instrument for Service

Sealed Air Corporation (Commerce, California 90001). Air Cap looks like a plastic sheet filled with air bubbles. Use the pink (antistatic) Air Cap™ to reduce static electricity. Wrapping the instrument several times in this material will protect the instrument and prevent it from moving in the carton.

- 4** Seal the carton with strong nylon adhesive tape.
- 5** Mark the carton “FRAGILE, HANDLE WITH CARE”.
- 6** Retain copies of all shipping papers.

Agilent Technologies Service Offices

Before returning an instrument for service, call the Agilent Technologies Instrument Support Center at (800) 403-0801, visit the Test and Measurement Web Sites by Country page at <http://www.tm.agilent.com/tmo/country/English/index.html>, or call one of the numbers listed below.

Agilent Technologies Service Numbers

Austria	01/25125-7171
Belgium	32-2-778.37.71
Brazil	(11) 7297-8600
China	86 10 6261 3819
Denmark	45 99 12 88
Finland	358-10-855-2360
France	01.69.82.66.66
Germany	0180/524-6330
India	080-34 35788
Italy	+39 02 9212 2701
Ireland	01 615 8222
Japan	(81)-426-56-7832
Korea	82/2-3770-0419
Mexico	(5) 258-4826
Netherlands	020-547 6463
Norway	22 73 57 59
Russia	+7-095-797-3930
Spain	(34/91) 631 1213
Sweden	08-5064 8700
Switzerland	(01) 735 7200
United Kingdom	01 344 366666
United States/Canada	(800) 403-0801

Index

A

- adapter cable, 1-3, 1-4
- Agilent 54701A active probe, 2-11
- Agilent 83492A
 - connections, 1-7
 - maximum input level, 1-5
- Agilent offices, 4-23

B

- Bellcore GR-253-CORE, 2-5
- block diagram, 2-7
- bypass mode, 2-4, 2-5

C

- cabinet, cleaning, iii
- calibration cycle, 3-2
- care
 - of cabinet, iii
- care of fiber optics, 1-2
- channel
 - key, 1-2
 - setup, 1-2
- Channel key, 2-3
- characteristics, defined, 3-2
- classification
 - product, iii
- cleaning
 - adapters, 4-19
 - cabinet, iii
 - fiber-optic connections, 4-10, 4-18
 - non-lensed connectors, 4-18
- CLOCK Auxiliary Output connector, 2-5
- compensation
 - Agilent 54701A active probe, 2-11
 - insertion loss, 2-9
 - other devices, 2-12
 - passive probe, 2-11
- compressed dust remover, 4-17
- connector
 - care, 4-10
- cotton swabs, 4-17
- customer assistance, iv

D

- damaged shipment, 1-3

- DATA Auxiliary Output connector, 2-5
- data rate
 - indicator lights, 1-5
- data rates, 2-2
 - multiple of, 2-8
- declaration of conformity, 3-8
- dust caps, 4-18

E

- electrostatic discharge, 1-2, 4-8
- error messages, 4-5
- error performance analyzers, use with, 2-3
- ESD
 - reducing damage caused by ESD, 4-9
 - static-safe work station, 4-9
- extender cables, 1-3

F

- fiber
 - adapters, 4-2
 - care of, 1-2
 - connections on Agilent 83492A, 1-7
 - multimode, 2-2
 - reflections, 2-6
 - single-mode, 2-2
 - single-mode connections, 2-6
- fiber optics
 - cleaning connections, 4-10
 - connectors, covering, 4-21
- firmware
 - upgrade kit, 1-2
 - version required, 1-2
- foam swabs, 4-17
- front panel, 2-4
 - adapters, 4-2
 - features, 2-4
- fuse
 - values, iii

G

- GPIO programming, 2-3
- green light, 1-5

Index

I

IEC Publication 61010-1, iii
input
 connector, 4-10
Input connector, 1-2, 1-7
input connector, 2-2
input signal, maximum safe, 1-5
insertion loss, 2-3, 2-6
 compensation, 2-9
instrument
 returning for service, 4-20
ITU-T G.957, 2-5

M

mainframe troubleshooting, 4-3
maximum input level, 1-5

O

Output connector, 2-5

P

packaging for shipment, 4-21
plug-in module
 serial number, 1-3
programming, 2-3

R

red light, 1-5
regulatory information, 3-2
responsivity, testing, 1-4
returning for service, 4-20

S

safety, iii
 laser classification, iii
safety information, iv, 1-3, 2-3
sales and service offices, 4-23
SELECT key, 1-5, 2-4
serial number, 1-3
service, 4-20
 returning for, 4-20
 sales and service offices, 4-23
shipping

 procedure, 4-20
single-mode fiber, 2-6
specifications, 3-2
 Agilent 83491A, 3-3
 Agilent 83492A, 3-4
 Agilent 83493A, 3-6
 defined, 3-2
 operating, 3-7
 temperature range, 3-2
swabs, 4-17

T

technical assistance, iv
testing, responsivity, 1-4
trigger bypass mode, 2-4, 2-5
Trigger On Data light, 2-4
troubleshooting, 4-3

U

Unlocked light, 1-6, 2-5, 2-8