

4.0 OPERATING INSTRUCTIONS

The GBC Shredmaster 1236S and 1636S shredders can shred most office paper documents, staples, and standard paper clips. The shredding of other metal items may damage the shredder. Plastic materials such as charge cards, covers, inserts, and film may be shredded occasionally, however, extended shredding of such materials will prematurely dull the cutters,

The shredder control panel is shown in figure 4.0.1. To start shredding, press the white "ON" push button and feed the paper to be shredded into the throat of the shredder. Never exceed the maximum capacity of the shredder. To turn the shredder off press the red "OFF/REV" push button.

When the shred bag becomes full, the bag sensor flap will automatically turn the shredder off. To resume shredding push the shreds down into the bag or replace it, and then press the white "ON" push button.

If too much paper is inserted into the feed throat, the shredder will automatically reverse to eject the paper, and turn off. To resume shredding, reduce the number of sheets to be shred and depress the white "ON" push button. To clear a severe jam that is not automatically ejected by the shredder, reverse the shredder by depressing the "OFF/REVERSE" push button while pulling firmly on the paper in the throat, or rock the paper through the cutters by alternately depressing the white "ON" and red "OFF/REVERSE" push buttons. In cases of severe jams the thermal overload circuit of the motor may be triggered and the unit will appear to be "dead". Wait a few minutes and allow the motor to cool and then clear the jam.



Figure 4.0.1

5.0 TROUBLESHOOTING

5.1 Principles of Operation

The shredder uses rapidly rotating cutting shafts that are driven by an electric motor to shred paper. Both electrical and mechanical principals are involved.

5.1.1 Electrical Operation

The electrical schematic diagram and the electrical wiring diagram for the 115 VAC shredders are shown in figures 5.4 and 5.5 respectively. The electrical circuit is comprised of the following electrical components.

1. **Flap switch (S1).** The flap switch interrupts the current path through the hot leg of the circuit if activated by a full shred bag.
2. **Relay (R1).** The relay is active in the "ON" mode only. The coil of the relay is energized initially by depressing the "ON" push button of the main control switch (S3). When the relay is activated, power is supplied to two current paths.

The first current path is from the hot leg of the circuit through the reverse switch (S2), main control switch (S3), and coil of the relay to the neutral leg of the circuit. This current path keeps the relay activated when the "ON" push button of the main control switch is released.

The second current path is from the hot leg to the neutral leg of the circuit, through two parallel circuits. The first circuit is through the run coil of the motor (M1), the second is through the main control switch (S3), starting capacitor (C1), start coil of the motor (M1).

3. **Reverse (S2).** The reverse switch is in series with the the coil of the relay. When this switch is activated, it opens to interrupt the current path through the relay coil, turning the shredder off.

5.0 TROUBLESHOOTING (Continued)

5.1.1 Electrical Operation (Continued)

4. **Motor (M1).** The motor is a single phase, 200 Watt, continuous duty, AC motor with both a run coil and start coil. A centrifugal switch is in series with the start coil. The centrifugal switch is closed when the motor is at rest and opens, to disconnect the start coil, when the motor has reached a predetermined speed. The centrifugal switch acts as the trigger to activate the auto - reverse feature of the shredder.
5. **Starting capacitor (C1).** The starting capacitor is in series with the start coil of the motor and aids the motor in starting.
6. **Main control switch (S3).** This dual push button switch controls the start, stop, reverse and auto - reverse modes of the shredder.

When the "ON" push button is depressed, switch contacts D2 - C2 close to activate the the relay. Simultaneously, switch contacts A4 - B4 and A2 - B2 close to allowing current to pass through the start coil of the motor in a direction that will cause forward rotation. The centrifugal switch of the motor will open to disconnect the start coil when the motor comes up to speed.

When the "ON" push button is released, contacts D2 - C2, A2 - B2 and A4 - B4 are broken. Simultaneously, contact A3 - B3 and A1 - B1 are closed, this reverses the direction of the current path through the start coil of the motor. If the speed of the motor drops at this time, the centrifugal switch will close, allowing current to pass through the start coil. Because the direction of the current path has been reversed by releasing the "ON" push button, the motor will immediately start to run in reverse.

5.0 TROUBLESHOOTING (Continued)

5.1.1 Electrical Operation (Continued)

When the "OFF / REV" push button is depressed, switch contacts F3 - E3 are opened to deactivate the relay and turn the shredder off. If this push button is depressed when the shredder is turned off, contacts F4 - E4 are closed and power is supplied to the motor. The motor will run in the reverse direction as long as this push button is depressed.

5.1.2 Mechanical Operation

During operation the upper cutting shaft is gear driven by the lower cutting shaft. The lower cutting shaft is chain driven by the motor.

The upper and lower cutting shafts are machined to a close tolerance so that when mated, there is a nominal gap of .001 of an inch between the cutting disks of the upper and lower shafts. Paper inserted between these rotating shafts is sheared. If after use, the gap between the cutter disks exceed .004 of an inch, paper may fold between the cutting disks without shearing. Cutter shaft adjustment is explained in Section 6.0.

5.2 General Troubleshooting

Malfunction corrections are based on visual observation by the operator. The causes of the malfunctions are isolated by the symptom of the malfunction and noting at which point in the operating cycle the malfunction occurred. Malfunctions that occur during operation can be pinpointed to a defective electrical circuit or to a mechanical part by referring to the Principles of Operation in the preceding paragraphs and to the electrical schematic diagrams and the electrical wiring diagrams.

5.0 TROUBLESHOOTING (CONTINUED)

5.3 Troubleshooting Guide Chart

The troubleshooting guide chart that follows is arranged in order of the normal operational sequence. When a malfunction occurs, read down the SYMPTOM column until you reach the appropriate description for your symptom. Read the corresponding PROBABLE MALFUNCTION, and then perform the recommended procedure in the CORRECTIVE ACTION column. When replacing electrical components having push on type terminals, tag the electrical leads that are removed to facilitate reconnecting them. Refer to the wiring diagram in figure 5.5 to resolve any wiring difficulties that may occur.

Warning: Always unplug the shredder to avoid possible severe electrical shocks before attempting to perform any repair.

5.3 Troubleshooting Guide Chart

SYMPTOM	PROBABLE CAUSE	CORRECTIVE ACTION
Motor does not run. No indication of power.	Power cord disconnected.	Connect power cord to outlet.
	Shred bag full	Replace shred bag.
	Flap switch bad or misaligned.	Perform continuity check and replace or adjust flap switch as needed.
	Main control switch bad.	Press ON switch and test for continuity across terminals A2-B2, A4-B4, and C2-D2. Replace Switch if defective.
	Relay bad.	Perform continuity test, replace relay if defective.
Motor hums but does not run.	Reverse switch is bad.	Test for continuity.
	Cutting head jammed.	Unjam cutting head.
	Relay bad.	Perform continuity test and replace relay if defective.
	Main control switch bad.	Press ON switch and test for continuity across terminals A2-B2, A4-B4, and C2-D2. Replace switch if defective.
	Motor defective.	Test and replace motor if defective.
Motor continues to run in reverse after a jam.	Reverse - stop switch is bad.	Perform continuity test and replace switch if bad.
	Reverse switch bad.	Perform continuity test and replace switch if bad.

5.3 TROUBLESHOOTING GUIDE CHART (Continued)

SYMPTOM	PROBABLE CAUSE	CORRECTIVE ACTION
Motor does not reverse when jammed.	Main control switch bad.	Perform continuity test across switch terminals A3 - B3 and A1 - B1. replace switch if bad.
Shredding capacity is diminished.	Paper jammed in cutters.	Unjam cutters.
	Cutting head is not properly aligned.	Properly align cutting head on base
	Cutters out of adjustment.	Adjust cutter locknut.

5.4 Electrical Schematic Diagram 115 VAC

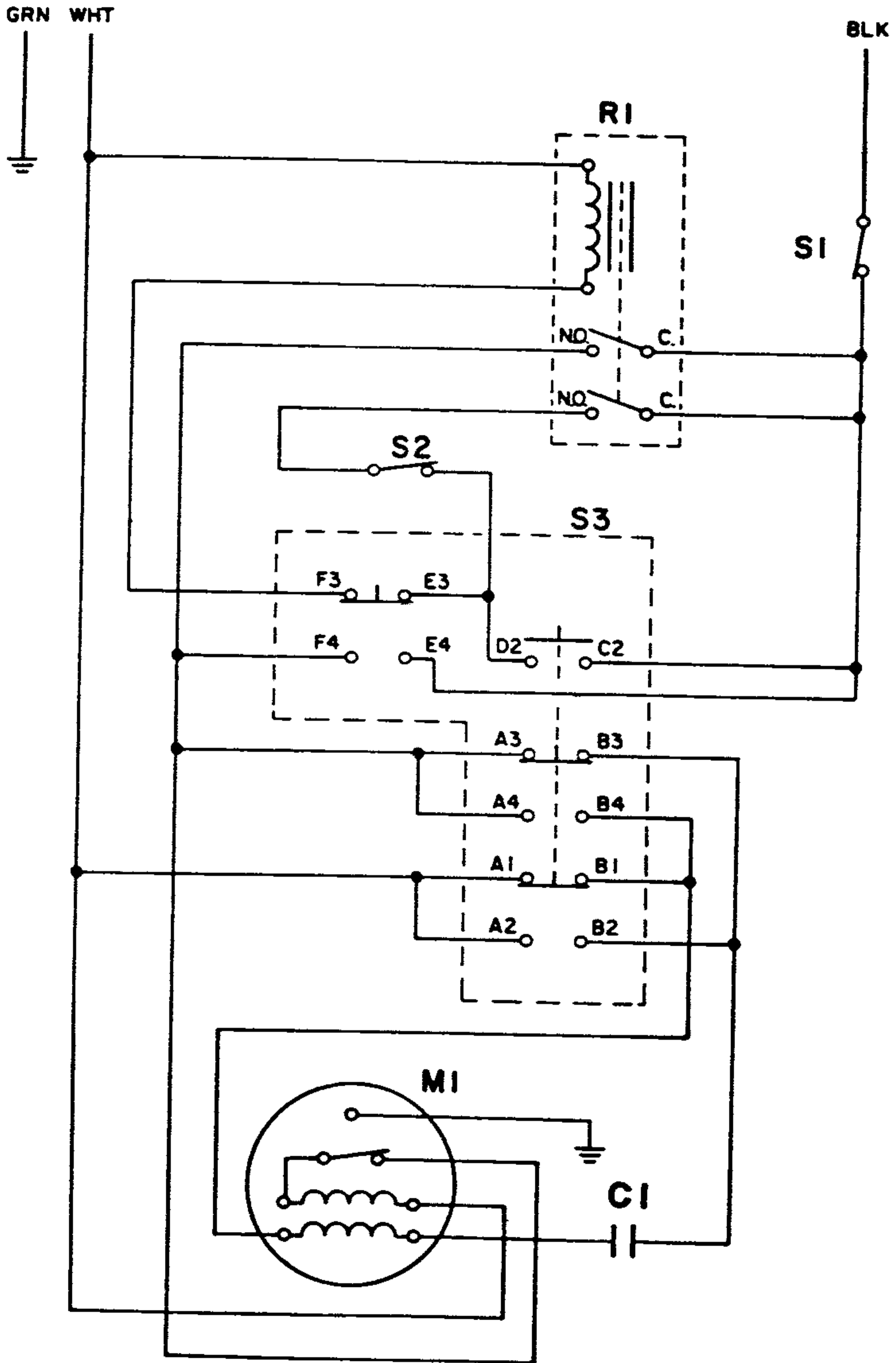

5.5 Electrical Wiring Diagram 115 VAC

