

**XF, WXF &
XP, WXP
Series
Foot Pump Operated
Scissor Lifts
Installation, Operation
and Service Manual**

Model Number _____

Serial # _____

Date placed in service _____

**IMPORTANT: READ CAREFULLY
BEFORE INSTALLING OR OPERATING LIFT**

Part orders are subject to a \$50 minimum charge.



This manual was current at the time of printing. To obtain the latest, most updated version, please contact Presto Lifts Customer Service Department or go to our website: www.PrestoLifts.com -- you will find a complete list of current owner's manuals to print.

CONTENTS

SECTION 1: Introduction	4
Responsibility of Owners and Users.....	5
Safety Alert Symbols and Signal Words.....	6
SECTION 2: Safety	7
SECTION 3: Installation	8
A. Uncrating and Inspection	8
B. Installing	8
C. Hydraulics	8
D. Testing Lift No Load	9
SECTION 4: Operation	9
A. Method Of Operation.....	9
B. Operation Procedures	9
SECTION 5: Maintenance	10
A. Routine Maintenance	10
B. Routine Checks	10
SECTION 6: Service	10
A. Replacing Cylinder Seals.....	10
B. Replacing Leg Rollers	11
SECTION 7: Troubleshooting	12
A. Standard Replacement Parts	13
 LIST OF FIGURES:	
Fig. 1 Maintenance Chock	8
Fig. 2 Foot Pump Assembly.....	14
Fig. 3 Handle/Caster Plate Assembly	15
Fig. 4 Anchor Bolt Details	15
Fig. 5 Hydraulic Schematic	15
Fig. 6 Maintenance Position	16
Fig. 7 Cylinder Assembly	17
Fig. 8 Hydraulic System Under Caster Plate (Prior to 10/6/04)	18
Fig. 9 Hydraulic System Under Caster Plate (After 10/7/04).....	19
Table 1 Hydraulic Oil Specifications	20
 RESTOCKING POLICY	21
ORDERING REPLACEMENT PARTS.....	22
RETURN GOODS AUTHORIZATION POLICY	23
WARRANTY	24

SECTION 1

INTRODUCTION

The Presto XF & XP Series Lightweight Scissor Lifts are designed for use in most manufacturing and assembly environments. They provide lifting, lowering, positioning and transporting of a wide variety of materials and components. They are available in portable and stationary models with foot pump operation.

The Scissor lift has a nameplate, which provides the load rating, serial number and model identification. Please refer to these numbers when ordering parts or requesting further information.

**WHERE UNIQUE SITUATIONS OR APPLICATIONS ARISE,
WHICH ARE NOT COVERED IN THIS MANUAL,
CALL PRESTO LIFTS SERVICE DEPARTMENT FOR FURTHER ASSISTANCE.**

The XF and XP Series Scissor Lifts have lift capacity of 1000 lbs and 1500 lbs. The lift is raised

Responsibility of Owners and Users

Inspection and Maintenance

The device shall be inspected and maintained in proper working order in accordance with Presto's owner's manual.

Removal from Service

Any device not in safe operating condition such as, but not limited to, excessive leakage, missing rollers, pins, or fasteners, any bent or cracked structural members, cut or frayed electric, hydraulic, or pneumatic lines, damaged or malfunctioning controls or safety devices, etc. shall be removed from service until it is repaired to the original manufacturer's standards.

Repairs

All repairs shall be made by qualified personnel in conformance with Presto's instructions.

Operators

Only trained personnel and authorized personnel shall be permitted to operate PowerStak.

Before Operation

Before using the device, the operator shall have:

- Read and/or had explained, and understood, the manufacturer's operating instructions and safety rules.
- Inspected the device for proper operation and condition. Any suspect item shall be carefully examined and a determination made by a qualified person as to whether it constitutes a hazard. All items not in conformance with Presto's specification shall be corrected before further use of the PowerStak.

During Operation

The device shall only be used in accordance with this owner's manual.

- Do not overload.
- Ensure that all safety devices are operational and in place.

Modifications or Alterations

Modifications or alterations to any Presto industrial positioning equipment shall be made only with written permission from Presto.

SAFETY ALERT SYMBOLS AND SIGNAL WORDS

The safety of all persons operating, maintaining, repairing, or in the vicinity of this equipment is of paramount concern. This is a powerful machine with moving parts, and is capable of causing personal injury if proper precautions are not taken. Therefore, throughout this manual, certain hazards have been identified which may occur in the use of the machine, and there are appropriate instructions or precautions which should be taken to avoid these hazards. In some cases, there are consequences which may occur if instructions or precautions are not followed. Below are the symbols and signal words along with their definitions referenced from ANSI Z535.4 - Product Safety Signs and Labels.

Safety Alert Symbols

These are the safety alert symbols.. They are used to alert you to potential physical injury hazards. Obey all safety messages that follow this symbol to avoid possible injury or death.



For use with DANGER signal word
(Red Background)



For use with WARNING signal word
(Orange Background)



For use with CAUTION signal word
(Yellow Background)

Signal Words

The meaning of different signal words as defined by ANSI Standard Z535.4 indicates the relative seriousness of the hazardous situation.



(Red Background)

DANGER indicates a hazardous situation which, if not avoided, will result in death or serious injury.



(Orange Background)

WARNING indicates a hazardous situation which, if not avoided, could result in death or serious injury.



(Yellow Background)

CAUTION, used with the safety alert symbol, indicates a hazardous situation which, if not avoided, could result in minor or moderate injury.



(Blue Background)

NOTICE is used to address practices not related to personal injury.




(Green Background)

SAFETY INSTRUCTIONS (or equivalent) signs indicate safety-related instructions or procedures.

SECTION 2

SAFETY

The safety of all persons installing, using, servicing, or working near the unit is of paramount concern to Presto Lifts. The lift is a powerful machine with moving parts, and is **capable of causing personal injury if proper precautions are not taken**. Therefore, throughout this manual, Presto Lifts has identified certain hazards, which may occur in the use of the unit, and provided appropriate **instructions** or precautions that should be taken to avoid these hazards. In some cases, Presto Lifts' has also pointed out the **consequences** that may occur if Presto Lifts' instructions or precautions are not followed. Presto Lifts uses the following nationally recognized system for identifying the severity of the hazards associated with its products:

 **DANGER** – Immediate hazard that will result in severe personal injury or death.

 **WARNING** – Hazard or unsafe practice, that could result in severe personal injury or death.

 **CAUTION** – Hazard or unsafe practice, that could result in minor personal injury or property damage.

In the interest of safety, please read the entire manual carefully. You must understand the material in this manual before you install, use, or service the unit. If you have any question about any of the instructions in this manual, please contact Presto Lifts Inc. at 1-800-343-9322.

and lowered by scissor legs, which are powered by a foot operated hydraulic pump and cylinder assembly. Therefore, great care must be exercised during the installation, operation and maintenance of the lift. **DO NOT INSTALL OR OPERATE THIS LIFT WITHOUT FIRST READING AND UNDERSTANDING THIS MANUAL.**

In order to provide for the safe operation of the scissor lift, Presto Lifts has identified certain hazards, which may occur during the installation, maintenance and use of these lifts. For safety reasons, the XF & XP Series lifts with standard tabletop are designed to be serviced in a collapsed position. Lifts with oversized tabletops require special handling. (See Section 5, Maintenance)

⚠️WARNING

Do not perform any repair work on lifts with a load on the platform or with the table in a raised position. All personnel must stand clear of the lift when table is in motion.

- Do not put hands or feet under lift table.
- Do not work under table without securing lift.
- Do not stand, sit, or climb on the lift.
- Do not use the lift on soft, uneven or unstable surfaces.
- Do not exceed load capacity.
- Do not place load on moving lift.
- Place loads in center of table and secure loads properly.
- Do not raise or lower lift while maneuvering.
- Do not lower foot pump operated lifts quickly or with jerky motions.

SECTION 3 INSTALLATION

A. UNCRATING AND INSPECTION

The XF & XP Scissor Lifts have been specially packaged to prevent damage in shipment. Upon receipt of the lift, uncrate following the special instructions attached to the lift's outer sleeve. With the lift in a collapsed position, carefully raise the top to its over center position (see figure 6), secure in place, then check the following:

⚠️CAUTION

Lifts with oversized tabletops must not be overextended since doing so may disassociate the cylinder base from its socket. (See Section 5, Maintenance)

1. Check for signs of damage especially to the cylinder and hydraulic hoses.
2. Check connections for leaks and tightness.
3. Inspect for bent or damaged metal parts.

⚠️CAUTION

When moving the lift, do not attempt to pick it up by the tabletop. The lift should be picked up by the base only.

B. INSTALLING

1. HANDLE ASSEMBLY

- a. Portable lifts have the push handles removed for ease of shipping. Handles should be inserted in the holders until they bottom out, then tighten the set screws on each holder with an allen wrench (see figure 3)
- b. Stationary lifts have a stability handle. The stability handle is installed using the bolts, nuts and lock washers provided.
- c. Foot operated lifts have a control knob, rod assembly and foot pedal which must be attached. To attach the control knob and rod, remove the knob and insert the rod through the guide on the handle. Place the adapter end of the control rod over the shaft. Lock in place using the Allen set screws provided. Now replace the knob on the rod and secure with the Allen screws provided (see figure 3).

The control rod guide must line up vertically with the flow control shaft. To attach the pedal, insert pedal shaft in pump holder and bolt in place with bolts provided.

2. FLOOR INSTALLATION

- a. The floor in the installation area should be flat, stable and free from debris and surface defects.
- b. Place lift in exact operating position. Make sure the complete base of the lift is in contact with the floor. Where there is no contact, base may be shimmed or grouted to make contact.
- c. All stationary lifts are provided with anchor holes in the base. It is recommended that stationary lifts be bolted in place (see figure 4).

⚠️CAUTION

Lifts with oversized tabletops must be secured to the floor with 4 anchor bolts with a minimum of 1000 lbs. pullout strength for each bolt.

C. HYDRAULICS

1. Use only hydraulic oils for these lifts. The lift has been supplied with Conoco Super Hydraulic 32. When adding fluid, use only the recommended oils

- listed in Table 1.
2. Before using, check oil level and fill if necessary. Check fittings for tightness. See Troubleshooting (see Section 7).

⚠ CAUTION

XF & XP Scissor lifts are designed for normal factory environments. Where low or below freezing temperatures may occur, special fluid must be used (consult service department).

⚠ WARNING

Do not use automotive hydraulic, brake or transmission fluids. They will damage seals and pose a serious fire hazard.

D. TESTING THE LIFT WITH NO LOAD:

1. Before testing the lift, clear the area of packaging and loose material. Be sure there are no obstructions above the lift. Turn flow control knob clockwise and counter clockwise to verify proper installation—clockwise will reduce flow and close the valve. With the valve partially opened (1/2 turn), pump the pedal several times. The unit should rise. If the lift does not rise, review procedures. If necessary consult Troubleshooting (see Section 7).

⚠ CAUTION

Do not over tighten the flow control knob. It may cause damage to the needle valve seat or strip the control knob from the shaft assembly. To lower lift, open the control valve slowly by turning the knob counterclockwise and observe lift lowering speed. The greater the turn, the greater the lowering speed.

SECTION 4 OPERATION

A. METHOD OF OPERATION:

FOOT PUMP

The XF & XP scissor lifts are equipped with a pump assembly and individual flow control mechanism.

To raise the lift, close the flow control knob clockwise. Depressing the foot pedal fully will pressurize the cylinder. This will cause the cylinder to extend. The scissor will separate and thereby raise the tabletop. When the foot pedal is released, a spring will return the pedal to its original position and a check valve built into the pump will hold the table in an up position. The spring return stroke draws oil from the reservoir through a check valve, keeping the oil in the piston preparatory to its next lifting stroke.

To lower the lift, the flow control is opened by turning the knob counter clockwise slowly.

⚠ CAUTION

Opening or closing the flow control valve quickly will cause impact loading, which more than doubles the load effect on the lift and can cause serious damage.

B. OPERATION PROCEDURES:

In order to operate the lift, follow these operating procedures:

1. Read and understand all the instructions before operating. If the lift has modifications or accessories, read and understand their instructions.
2. Load the lift correctly.
 - a. Portable lifts: Place the load on the center of the tabletop. The load, center of gravity, must be within 6" of the lift tabletop center and equally distributed over 80% of the table.
 - b. Stationary lifts: Place the load on the center of the tabletop. The load, center of gravity, must be within 8" of the lift tabletop center and equally distributed over 80% of the table.
 - c. If the load is unstable or table may become unstable, fasten it into position.
 - d. For side and end loads, see derating chart (Table 2).

3. Operate the lift (foot pump)
 - a. To raise lift, close flow control valve and pump foot pedal.
 - b. To lower lift, open flow control valve carefully.
4. Wait until the lift has come to a complete stop before unloading lift.
5. Stand clear of lift when operating it in order to avoid injury.



- Do not stand, sit or climb onto the lift.
- Do not load or unload a moving lift.
- If the lift fails to move or exhibits strange movement or sound, stop immediately.
- Do not operate the lift until it has been checked and repaired.
- Obey all warning labels.
- Do not exceed maximum rated load.
- Maintain load within 80% of the lift platform area. The center of gravity of the load must be located within 6" of the center of the platform for portable lifts and 8" for stationary lifts.

SECTION 5

MAINTENANCE

Generally, the XF & XP series scissor lifts will require little maintenance. However, routine maintenance and inspection will minimize costly repairs or hazardous conditions.



Never go under or service a lift with the scissor mechanism unblocked. If possible, service the lift in a down position.

A. ROUTINE MAINTENANCE:

All routine maintenance should be performed monthly. Maintenance should be performed on the standard XF & XP series scissor lifts with standard tops, in a lowered height position. Raise the top to its over center position (see figure 6), secure in place and perform the routine listed checks (1 – 5).

For lifts with oversized platforms, the lift must be serviced in an up position. The following procedure must be followed prior to servicing:

- a. Raise the lift to the full up position.
- b. Place the appropriate chock in position as shown in figure 1 and figure 6.
- c. Lower the lift until the rollers come in contact with the chock.
- d. Perform the routine listed checks (1-5)



Wood blocks should be cut to the proper length and be of a hard wood variety. Check for defects or damage to the blocks prior to each usage.

B. ROUTINE CHECKS:

1. Check oil level. Add oil if necessary according to Troubleshooting (see Section 7).
2. Check rollers for signs of wear. Replace if damaged.
3. Check hydraulic lines for damage or leaking. Replace if damaged.
4. Check for oil spots on floor. Trace leak to determine proper repair.
5. Bearings on all lifts are permanently lubricated and under normal usage require no servicing.

C. TROUBLESHOOTING- FOOT OPERATED (see page 9).

SECTION 6

SERVICE

A. REPLACING CYLINDER SEALS:

(Seal kits are listed on page 10)

1. Lower the lift to its lowest position, then lift the top to its over center position and secure.
2. For lifts with oversized platforms, the cylinder is replaced while the lift is in an up position. To position lift in the up position, follow instructions for routine maintenance (5A a-c).
3. Disconnect the hydraulic hose from the cylinder and cap the line to prevent hydraulic fluid loss.

4. Loosen the set screws holding the cylinder pin.
5. Remove the cylinder pin.
6. Lift the cylinder out of the lift.



Hold the cylinder securely while removing the pin to prevent it from falling to the floor.

7. Clamp cylinder securely at the base end.
8. Completely collapse cylinder piston.
9. Push gland into the cylinder 1/8"- 3/16".
10. Remove retaining ring.
11. Remove piston rod, piston and gland from cylinder.
12. Remove rod nut, piston and gland.
13. Remove and replace seals and wipers.
14. Assemble piston and gland to piston rod.
15. Assemble rod nut to piston rod and torque to 100 ft./lb.
16. Lubricate piston and seals and install in cylinder.
17. Insert retainer ring.
18. Install cylinder, cylinder pin, set screws and hydraulic lines.
19. Fill reservoir.
20. a). For the lifts serviced in lowered position, lower tabletop completely.
b). For the lifts serviced in the up position, raise table and remove chocks.
21. Cycle lift 2-3 times adding oil if necessary.
22. Recheck reservoir oil level.

B. REPLACING LEG ROLLERS

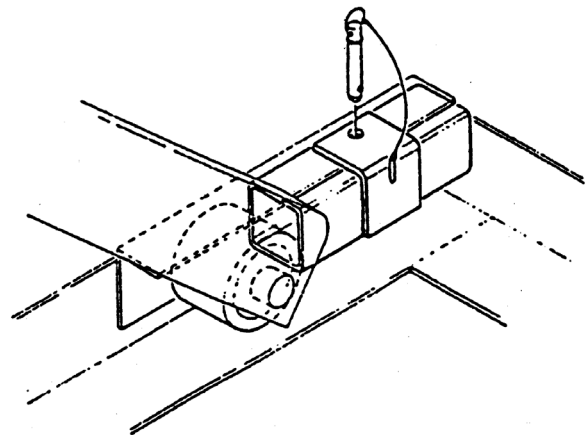
(Kit is listed on page 10)

1. a). For standard lifts, lower lift to its lowest position and hold down switch for an additional 10-20 seconds. Then lift the top to its over center position and secure.
b). For lifts with oversize or beveled platform secure the lift as follows: Raise the lift to its full raised position. Place a steel 7/8" or 1" bar through both outer scissor leg holes. Lower the

lift until the inner legs are firmly in contact with the bar.

2. Raise the leg assembly 2" and support with the yellow supplied safety chock.
3. Remove retainer clips, shield and rollers.
4. Clean and lubricate axle. Replace with new rollers, shields and clips.
5. a). For lifts serviced in a lowered position lower the tabletop completely.
b). For lifts serviced in the up position, raise table slightly and remove steel bars.

**FIGURE 1:
MAINTENANCE CHOCK**



TROUBLESHOOTING : FOOT OPERATED

PROBLEMS	PROBABLE CAUSE	SERVICE REQUIRED
Lift will not rise.	Low fluid.	Check fluid level. (1)
	Pump/air lock	Open flow valve and cycle pump. (2)
	Leak in suction line.	Check suction line from reservoir and pump for misconnects or leaks.
	Faulty Flow Control Valve.	Replace.
Lift raises, then slowly lowers.	Pump	Remove check ball and spring. Inspect valve seat. Clean and replace.
	Leaking fitting	Check fittings and lines for telltale oil spots.
	Faulty flow valve.	(3)

SECTION 7

TROUBLESHOOTING

1. On right hand side of caster plate you will find a square head plug.

- Remove the plug and fill oil well with hydraulic oil. Oil level should be between 3/4" to 1" from the top.

2. Priming Hydraulic system.

- Remove item #6 (lock rings) and remove item #5 (lever pin). (See Fig. 2)
Place a screwdriver through hole in top of pump where item #5 (lever pin) was installed in top of pump. Cycle pump by pulling the pump shaft up and then push back down until pump is primed. This may require several cycles to prime pump. Reassemble foot pump in reverse order.

3. If the lift tends to creep downward under a load. A speck of dirt may be obstructing the seating of the valve and allowing leakage. To correct, follow these instructions:

- Raise lift to full lifting height and then lower it to lowest point of lift. It may be necessary to do this five or six times. In lowering the lift, lower it in stages, that is, lower the lift six inches to a foot at a time. This will dislodge the dirt and lift will operate properly.
- If this does not correct the problem, replace valve.

STANDARD REPLACEMENT PARTS:

Description	Part #	Used on
Cylinder	1001-171-01	XP24-15
	1001-171-02	XP36-15
	1001-171-03	(W)XF24-10 & (W)XF24-15
	1001-171-04	(W)XF36-10 & (W)XF36-15
	1001-171-05	XP24-10
	1001-171-06	XP36-10
Cylinder seal kit	Contact Parts Dept. with model & serial number of machine.	
Roller kit	1000-067VR	All
Wheels:		
Swivel Caster w/ 5" x 2" Wheel	C101PH5	All XP
Swivel Caster w/ Cam Brake LH	C101PH5L-L	All XP
Swivel Caster w/ Cam Brake RH	C101PH5L-R	All XP
5" x 2" Wheel Assembly	C102PH	All XP
Foot Pump (see fig. 2)	1010-024	All XP, XF
Pump Body	1010-025	
Pump Spring	1010-009-01	
Pump Clip	M404	
Pump Fulcrum Pins	1010-008	
Pump Lever Assembly	1010-007VR	
Foot Lever	M436	
Foot Lever Pad	M437	
Release Rod assembly	1010-017-01	XF24, XF36, WXF24, WXF36
	1010-017-02VR*	XP24, XP36, WXP24, WXP36
	80001612VR**	All XP, WXP
	80001614VR**	All XF, WXF
Down Flow Valve	1010-019-01*	All XF, WXF, XP, WXP
	2533080**	All XF, WXF, XP, WXP
Black Knob	1010-019A	All XP, XF
Floor lock	77248-6	All XP, WXP

* Prior to 10/6/04

** 10/6/04 and later

FIGURE 2:
1010-024 FOOT PUMP ASSEMBLY

ITEM NO.	PART NO.	DRW NO.	QTY.	DESCRIPTION
1	1010-007VR	1010-007	1	LEVER ASSEMBLY
2	M436	48	1	FOOT LEVER
3	M437	49	1	FOOT LEVER PAD
4	1010-009-01	1010-009	1	COMPRESSION SPRING
5	1010-008	45	1	LEVER PIN
6	PSL28A	44	4	LOCK RING
7	1010-025	1010-025	1	FOOT PUMP SUBASSEMBLY
8	1001-204	1001-204	1	CAP, SPRING

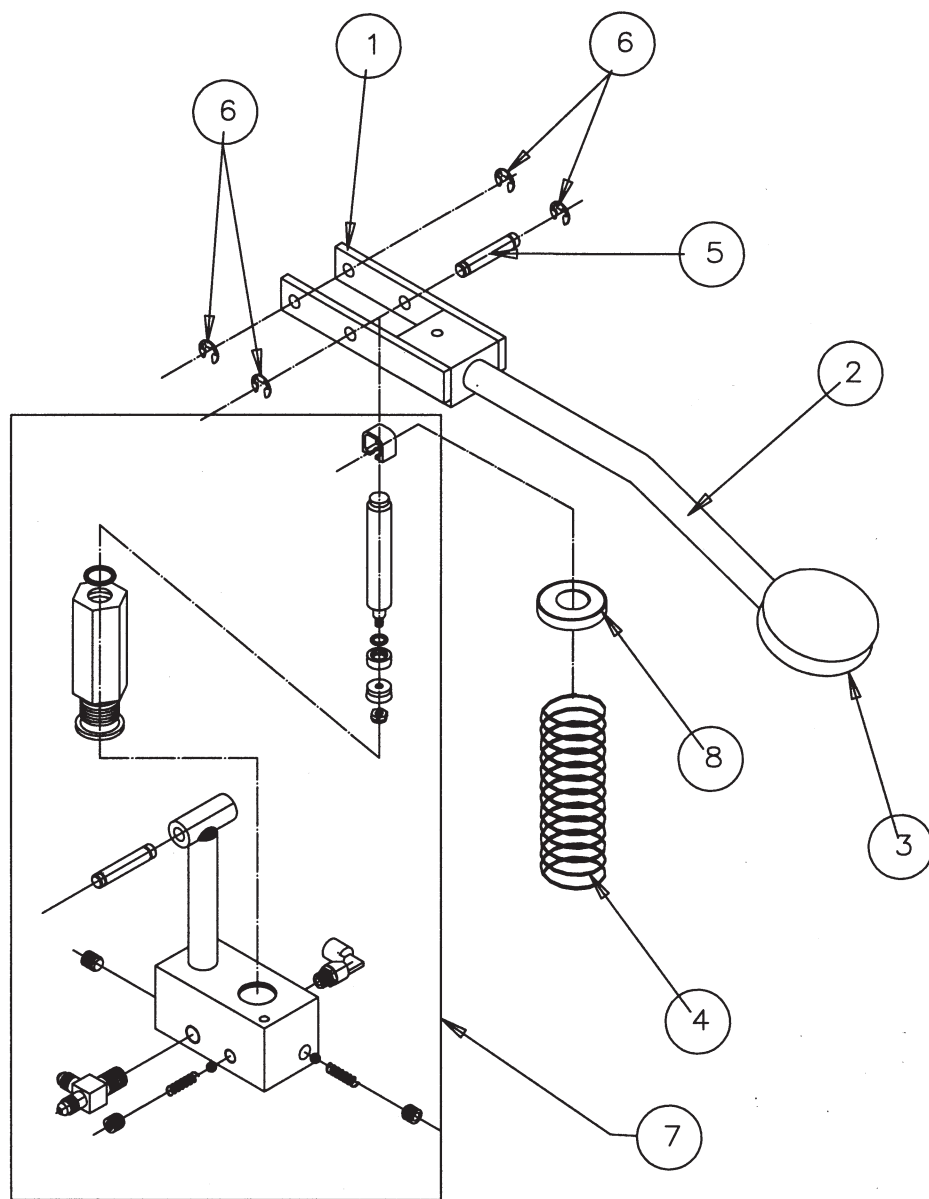
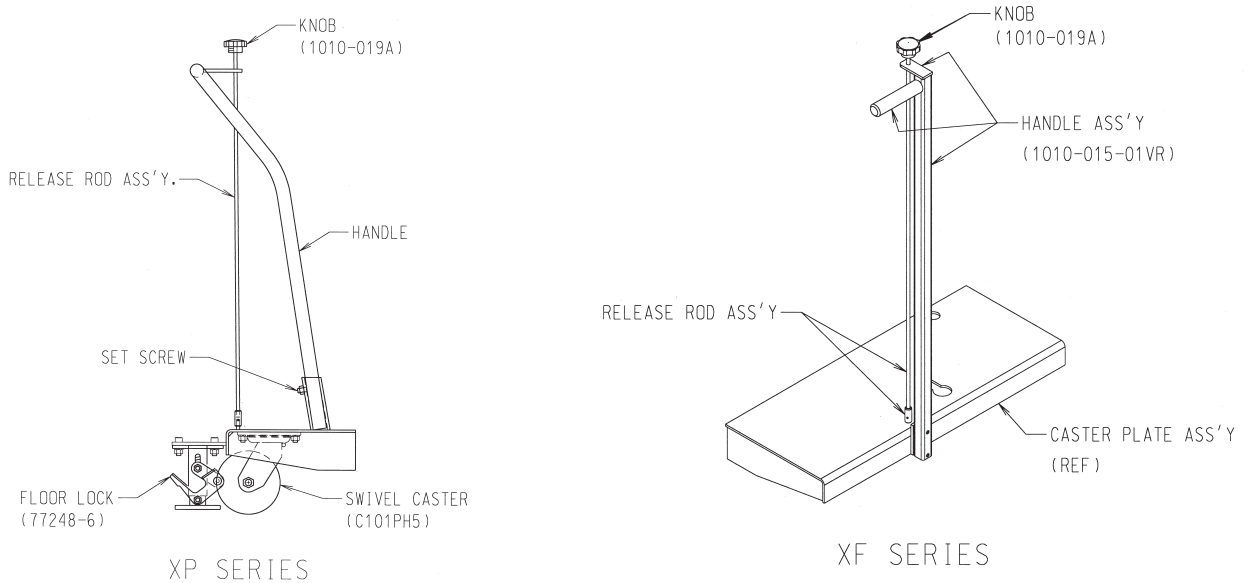
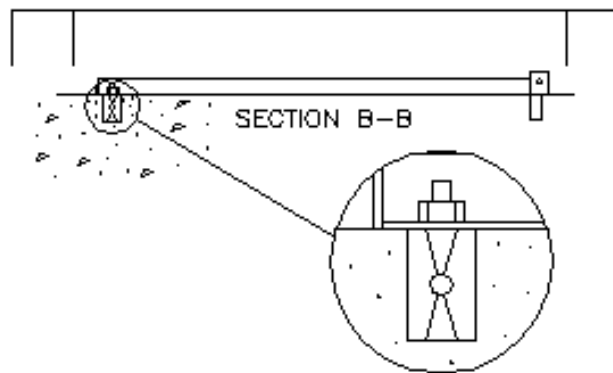


FIGURE 3: HANDLE/CASTER PLATE ASSEMBLY



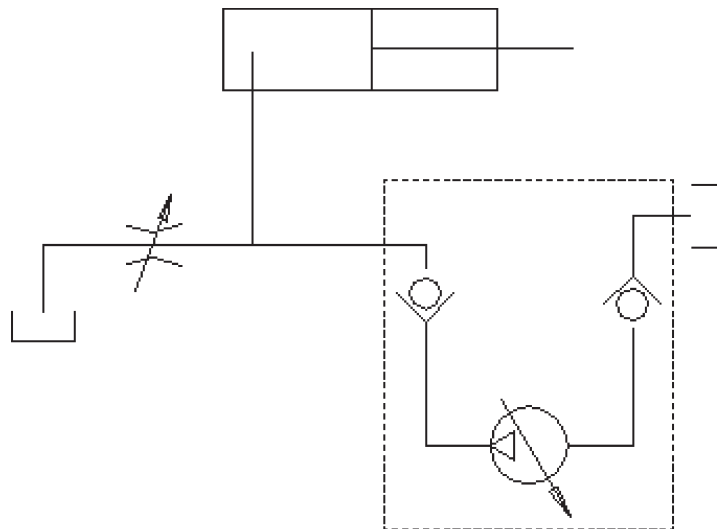
**FIGURE 4:
ANCHOR BOLT
DETAIL**

Side view of scissor lifting table showing anchor bolt details.

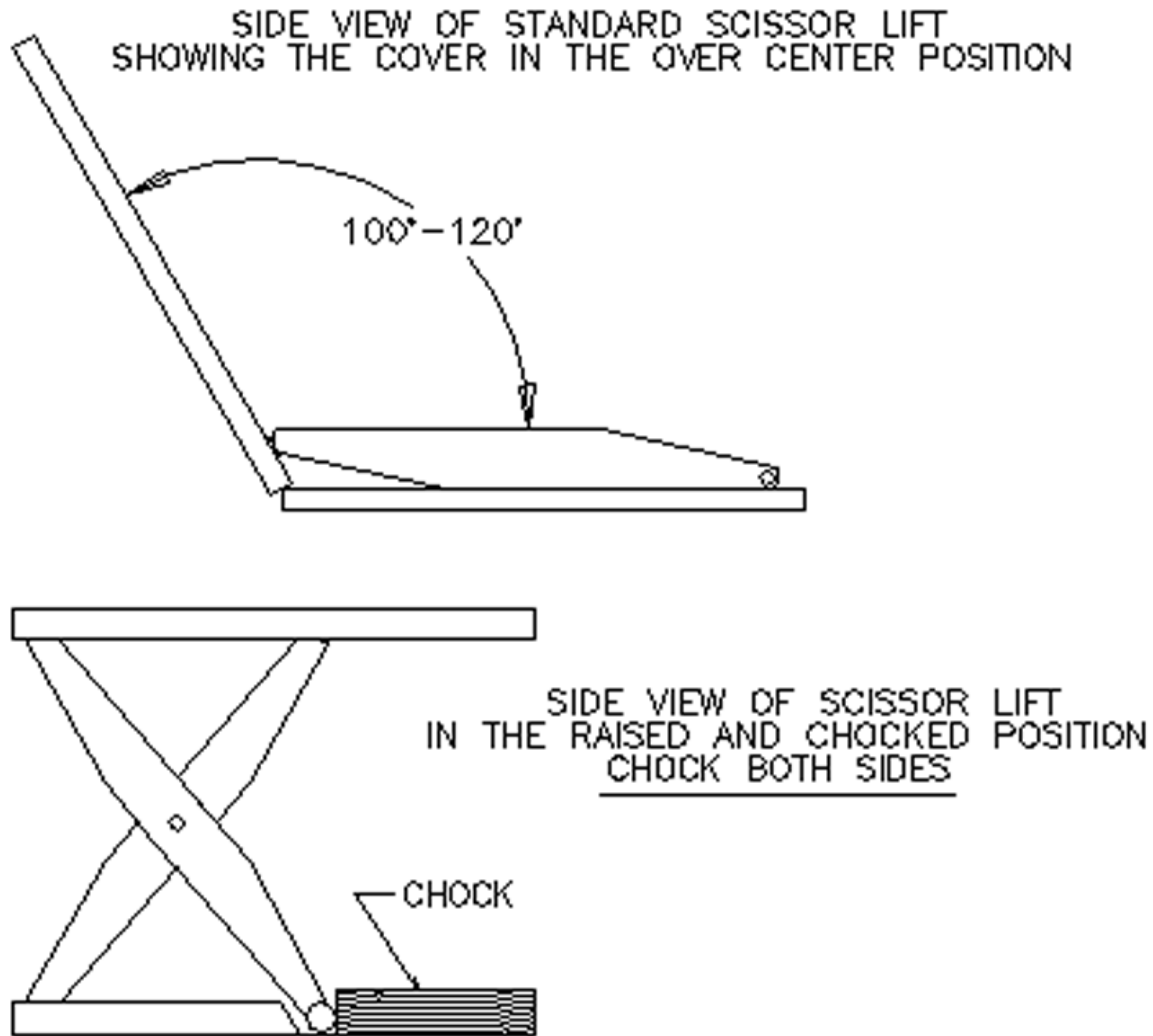


**FIGURE 5:
HYDRAULIC SCHEMATIC**

Hydraulic Pump Foot Operated
Unidirectional Piston Pump
These pumps are foot actuated piston to power single acting cylinder. Locking check holds the load in the up position. Adjustable orifice controls the down rate cycle of the lift.



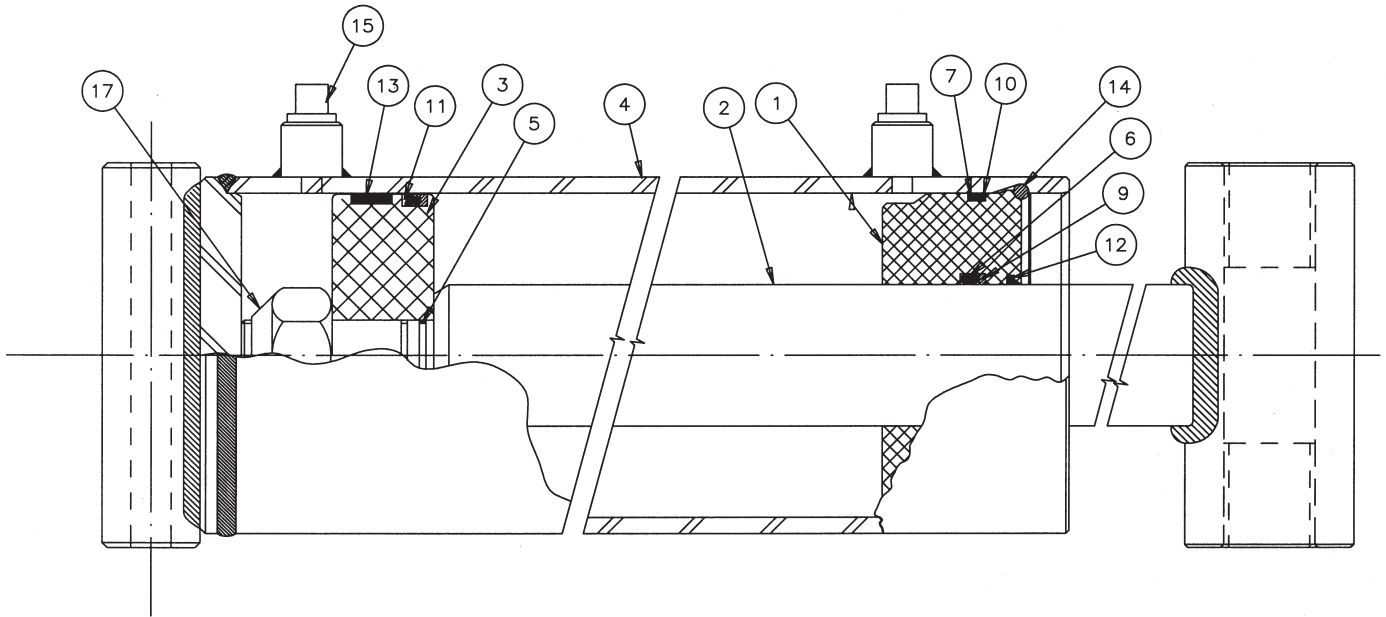
**FIGURE 6:
MAINTENANCE POSITION**



CHOCK SIZES: 2 REQUIRED LIFT

LIFT TRAVEL 24"	2x4x14"LONG
LIFT TRAVEL 36"	2x4x20"LONG

**FIGURE 7:
CYLINDER ASSEMBLY - 1001-171 Series**

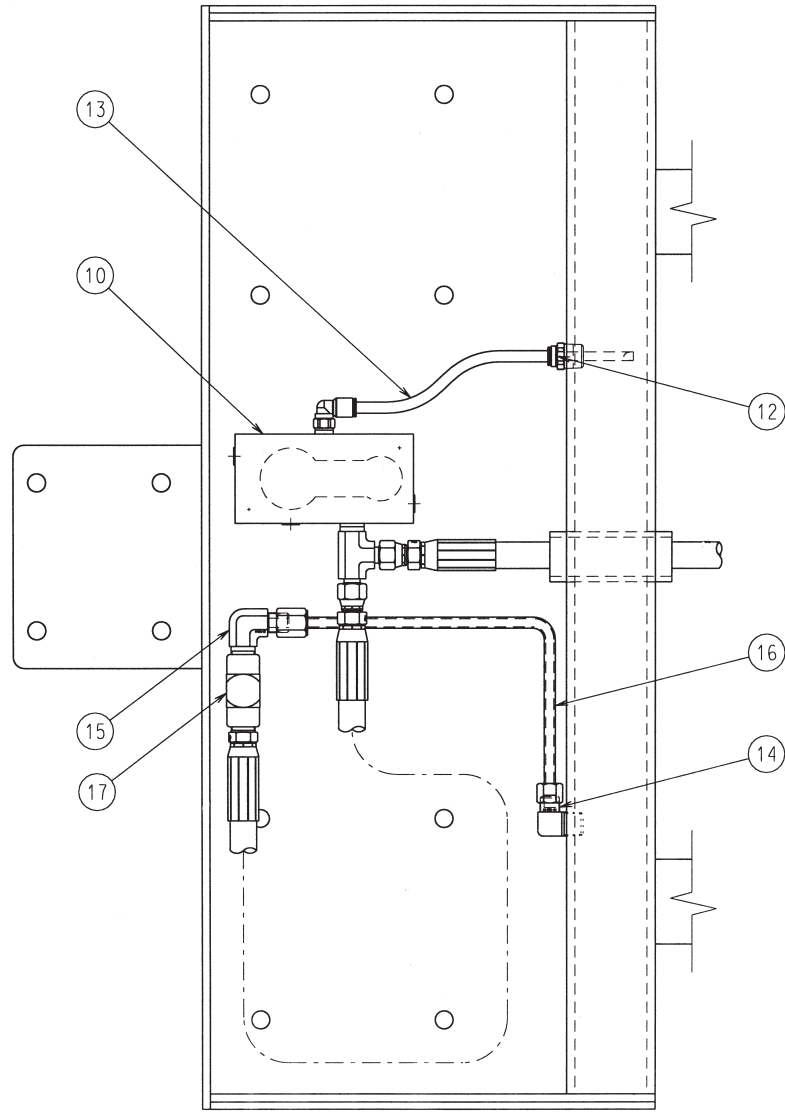


The only part available for this cylinder is the cylinder packing kit. Call parts dept. with the model & serial number of machine.

ITEM NO.	DESCRIPTION	QUANTITY
17	LOCKNUT	1
15	CAPLUG	1
14	RETAINING RING	1
13	WEAR RING	1
12	ROD WIPER	1
11	U-CAP/TYPE D	1
10	BACKUP RING	1
9	BACKUP RING	1
7	O-RING	1
6	O-RING	1
5	O-RING	1
4	BARREL ASSEMBLY	1
3	PISTON	1
2	ROD ASSEMBLY	1
1	GLAND	1

**FIGURE 8: _
HYDRAULIC SYSTEM
UNDER
CASTER PLATE**

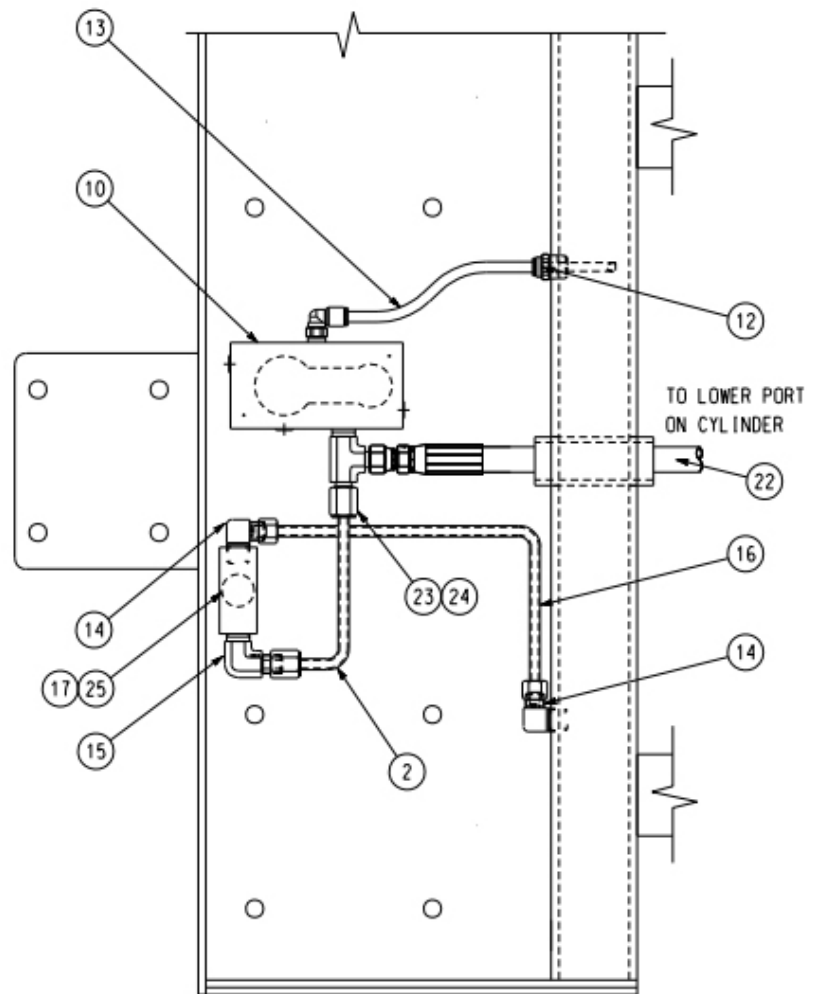
____ Prior to 10/6/04 and S/N V13556



ITEM NO.	QTY	DESCRIPTION
17	1	VALVE
16	1	TUBE
15	1	FITTING
14	1	FITTING
13	.33 FT	TUBE
12	1	CONNECTOR
10	1	FOOT PUMP

**FIGURE 9: _
HYDRAULIC SYSTEM
UNDER
CASTER PLATE**

After 10/7/04 and S/N V13556



ITEM NO.	PART NO.	QTY	DESCRIPTION
25	10030028	1	NUT, CASTER PLATE
24	2411117	1	FERRULE, TUBE
23	2411111	1	NUT, TUBE
22	Call with S/N	1	HOSE ASSEMBLY
17	2533080	1	VALVE
16	30000228	1	TUBE
15	H103B-02	2	FITTING
14	H103B-01	1	FITTING
13	H115-2000P	.33 FT	TUBE
12	H102B-2000	1	CONNECTOR1
10	1010-025	1	FOOT PUMP
2	Call with S/N	1	TUBE

TABLE 1 – Hydraulic Oil Specifications

If the lift will be used at normal ambient temperatures, Presto Lifts supplies the unit with Conoco Super Hydraulic 32 oil. This may be replaced by any other good quality oil with 150 SSU at 100° F and rust and oxidation inhibitors and anti-wear properties.

If the lift will be used at ambient temperatures below 0°F, use aircraft hydraulic oil. Use Type 15 aircraft hydraulic oil.

The following are equivalent to Conoco Super Hydraulic 32:

TYPE	MANUFACTURER
AW32	CITGO
DTE 24	EXXON/MOBIL
NUTO H32	EXXON/MOBIL
AMOCO AW32	CHEVRON (AMOCO CO.)



It is very important to keep the hydraulic oil free of dirt, dust, metal chips, water, and other contamination. Most of the problems with hydraulic systems are caused by contamination in the oil.

PARTS

Standard parts may be returned with a 20% restocking fee. Modified or custom-engineered parts are not returnable. Unfortunately, due to potentially concealed damage, all sales of electrical assemblies are final.

QUALITY ISSUES

Should you feel there is a quality problem, please contact the seller to ask questions and gather information on how to rectify the issue. Presto Lift Inc. reserves the right to determine potential credits, as a result of factory defects, based on its inspection of the merchandise.

GENERAL

All products shipped from our factory have passed Quality Assurance inspection and testing. The carrier of choice has signed for, and accepted the product in new working condition. The customer should inspect to ensure it is not received damaged, has no concealed damage or is not incomplete. Parts orders are determined to be complete based upon Presto Lift, Inc. inspection sheets and carrier shipping weights.

Ordering Replacement Parts

Presto Lifts has carefully chosen the components in your unit to be the best available for the purpose. Replacement parts should be identical to the original equipment. Presto Lifts will not be responsible for equipment failures resulting from the use of incorrect replacement parts or from unauthorized modifications to the unit.

Presto Lifts can supply all replacement parts for your lift. With your order, please include the model number and the serial number of the unit. You can find these numbers on the name plate. This plate is located within the scissors mechanism.

To order replacement parts, please call the Presto Parts Department. Parts are shipped subject to the following terms:

- FOB factory
- Returns only with the approval of our parts department.
- Credit cards preferred (except parts covered by warranty).
- Freight collect for truck (except parts covered by warranty).
- Freight – prepaid and invoice for small parcel shipments (except parts covered by warranty).
- The warranty for repair parts is 30 days from date of shipment.

Parts replaced under warranty are on a “charge-credit” basis. We will invoice you when we ship the replacement part, then credit you when you return the worn or damaged part, and we verify that it is covered by our warranty. Labor is not covered under warranty for Parts orders.

Presto Parts Department

50 Commerce Way
Norton, MA 02766

Telephone: 800-343-9322

FAX: 888-788-6496

Email: service@PrestoLifts.com

www.PrestoLifts.com

RETURN GOODS AUTHORIZATION POLICY

Presto Lifts provides the Return Goods Authorization (RGA) Policy, for specific models, as a courtesy to our distributors in the event they do not receive what they ordered. If a customer wishes to return a Presto Lifts product, please contact the Customer Service Department and request an RGA number. This request must be made on or before the fifteenth calendar day following the date of Presto Lifts' invoice for the merchandise. Not all units are returnable. Quantity orders and special designs cannot be returned under any circumstances. Presto Customer Service reserves the right for final judgment on all product returns.

The RGA number must appear on the outside of any packaging material for a return to be accepted and processed by Presto Lifts. Customers shipping returns from the Continental US, Canada, or Mexico have thirty (30) days from date of RGA issue to have the product arrive at Presto Lifts' facility. All merchandise must arrive Free on Board at Presto Lifts' facility or the shipment will be refused and returned to the sender. All credits are issued less restocking and refurbishing charges, regardless if the merchandise was damaged in transit.

Return addresses: please refer to your RMA for the address to which your product should be returned.

Presto Lift Inc.
715 Highway 77
Manila, Arkansas 72442

Telephone: 800-343-9322
Fax: 888-788-6496

Presto Lifts Limited Warranty Policy

Presto Lifts warrants all of its products against defects in the welded structural frame and, if applicable, scissor legs from faulty material and workmanship for a period of five (5) years from the date of invoice.

All other components have a limited warranty against defects in faulty material and workmanship for a two (2) year period from the date of invoice and 30 day limited warranty on labor. Please note that prior authorization from Presto Lifts is required on all warranty work.

There are no implied warranties of any kind, more specifically, there are no warranties of merchantability or fitness for any particular purpose. Presto Lifts' sole warranty shall be as set forth in this limited warranty.

Presto Lifts will elect to repair or replace a defective component without charge, if any components should become defective within the limited warranty period. Proof of purchase is required for warranty. The charge for shipping the defective component is the responsibility of the buyer and must be accompanied with an RGA number. The shipping charge to return the component to the buyer is the responsibility of Presto Lifts, Inc.

This limited warranty does not cover labor expense for removal or reinstallation of components after thirty days. This limited warranty shall not cover, among other things: damages resulting from foreign matter or water, failure to provide reasonable and necessary maintenance, and if applicable, use of product while charger is plugged into an AC outlet, or failure to follow operating instructions. The limited warranty is not valid for damage resulting from negligence, accident, unreasonable use, abuse or misuse, exceeding data plate capacities or altering the product without Presto Lifts authorization.

Presto Lifts expressly disclaims and excludes any liability for consequential, incidental, indirect or punitive damages or financial loss to people or property resulting from any breach of warranty or the operation or failure of this product.

Presto Lifts makes no representation that this product complies with local, state, or federal safety/product standards codes. Should this product fail to comply in any way with those codes, it shall not be considered a defect of materials or workmanship. Presto Lifts shall not be held liable for any damages resulting from noncompliance. It is the dealer's responsibility to exercise this limited warranty. This limited warranty is provided to the original purchaser (defined as the original end user) and is nontransferable. This constitutes the complete and final agreement involving Presto Lifts and limited warranty obligations for products.

MANY NEEDS REQUIRE MANY OPTIONS...

Presto LIFTS



LET PRESTO MEET THOSE NEEDS!

Call Presto Sales
for stock or
customized lift inquiries:
800-343-9322

Email: sales@prestolifts.com

